

## VMCS HEAVY DUTY ELECTRIC GRIDDLE TOP

### MODELS

VMCS-101

VMCS-102

VMCS-201

VMCS-202

### - NOTICE -

This Manual is prepared for the use of trained Hobart Service Technicians and should not be used by those not properly qualified.

This manual is not intended to be all encompassing. If you have not attended a Hobart Service School for this product, you should read, in its entirety, the repair procedure you wish to perform to determine if you have the necessary tools, instruments and skills required to perform the procedure. Procedures for which you do not have the necessary tools, instruments and skills should be performed by a trained Hobart Service Technician.

The reproduction, transfer, sale or other use of this manual, without the express written consent of Hobart, is prohibited.

This manual has been provided to you by ITW Food Equipment Group LLC ("ITW FEG") without charge and remains the property of ITW FEG, and by accepting this manual you agree that you will return it to ITW FEG promptly upon its request for such return at any time in the future.

# TABLE OF CONTENTS

|                                               |    |
|-----------------------------------------------|----|
| SERVICE UPDATES .....                         | 3  |
| SERVICE UPDATES .....                         | 3  |
| TIS DOCUMENT LIST - VMCS GRIDDLES .....       | 3  |
| TIS DOCUMENT LIST - VCCG GRIDDLES .....       | 3  |
| GENERAL .....                                 | 5  |
| INTRODUCTION .....                            | 5  |
| OPERATION AND FIELD INSTALLATION .....        | 5  |
| MODELS .....                                  | 5  |
| SPECIFICATIONS .....                          | 5  |
| TOOLS .....                                   | 5  |
| REMOVAL AND REPLACEMENT OF PARTS .....        | 6  |
| REMOVE CLAMSHELL FROM FRAME .....             | 6  |
| TOP CONTROL BOX COVER .....                   | 8  |
| POWER SWITCH .....                            | 9  |
| REMOVE HEATING SECTION FROM HANDLE ARMS ..... | 9  |
| INDICATOR LIGHTS .....                        | 12 |
| POWER CORD .....                              | 13 |
| HIGH LIMIT .....                              | 13 |
| CONTROL THERMOSTAT .....                      | 14 |
| HEATING ELEMENTS .....                        | 16 |
| ARM MECHANISM .....                           | 17 |
| SERVICE PROCEDURES AND ADJUSTMENTS .....      | 19 |
| GRIDDLE TOP MANUAL LIFT CHECK .....           | 19 |
| PLATE GAP ADJUSTER .....                      | 19 |
| THERMOSTAT TEST .....                         | 20 |
| HEATING ELEMENT TEST .....                    | 20 |
| ELECTRICAL OPERATION .....                    | 21 |
| COMPONENT LOCATION .....                      | 21 |
| COMPONENT FUNCTION .....                      | 21 |
| WIRING DIAGRAM .....                          | 22 |
| TROUBLESHOOTING .....                         | 23 |
| TROUBLESHOOTING .....                         | 23 |

# SERVICE UPDATES

## SERVICE UPDATES

NOVEMBER, 2018

- Added TIS document list.

May 2021

- Added REMOVE HEATING SECTION FROM HANDLE ARMS.

## TIS DOCUMENT LIST - VMCS GRIDDLES

| SERVICE TAB                  |                |
|------------------------------|----------------|
| Document Title               | Document Type  |
| VMCS Griddles Service Manual | Service Manual |

| SERVICE TAB (Multimedia)                                           |                                  |
|--------------------------------------------------------------------|----------------------------------|
| Document Title                                                     | Document Type                    |
| Repairing Flood-Damaged Food Equipment                             | Misc                             |
| VMCS Operation & Installation Manual                               | Operator                         |
| VMCS Heavy Duty Electric Griddle Top                               | Specification Sheet              |
| Rating Plate Locations on Current Vulcan-Hart/Wolf Range Equipment | Technical Service Bulletin (TSB) |
| TSB 1037A Hobart to Vulcan "Common" Model Cross Reference List     | Technical Service Bulletin (TSB) |

| PARTS TAB                    |               |
|------------------------------|---------------|
| Document Title               | Document Type |
| VMCS Clamshell Parts Catalog | Parts Catalog |

## TIS DOCUMENT LIST - VCCG GRIDDLES

| SERVICE TAB                  |                |
|------------------------------|----------------|
| Document Title               | Document Type  |
| VCCG Griddles Service Manual | Service Manual |

| SERVICE TAB (Multimedia)                                            |                      |
|---------------------------------------------------------------------|----------------------|
| Document Title                                                      | Document Type        |
| Repairing Flood-Damaged Food Equipment                              | Misc                 |
| VCCG Series Heavy Duty Gas Griddles Operation & Installation Manual | Operator             |
| Fundamentals of Gas                                                 | Service Instructions |
| VCCG Series Heavy Duty Gas Griddles Specification                   | Specification Sheet  |

| <b>SERVICE TAB (Multimedia)</b>                                                                |                                      |
|------------------------------------------------------------------------------------------------|--------------------------------------|
| <b>Document Title</b>                                                                          | <b>Document Type</b>                 |
| Rating Plate Locations on Current Vulcan-Hart/Wolf Range Equipment                             | Technical Service Bulletin (TSB)     |
| TSB 0842 4 Position/3 Heat Switch - Ranges, Ovens, Broilers                                    | Technical Service Bulletin (TSB)     |
| TSB 1037A Hobart to Vulcan "Common" Model Cross Reference List                                 | Technical Service Bulletin (TSB)     |
| TSB 682 Griddle Lead Wiring Upgrading                                                          | Technical Service Bulletin (TSB)     |
| RobertShaw FS Flame Switch Recall Vulcan & Wolf Equipment Effected - PN <a href="#">713933</a> | Temporary Service Instructions (TSI) |

| <b>PARTS TAB</b>              |                      |
|-------------------------------|----------------------|
| <b>Document Title</b>         | <b>Document Type</b> |
| VCCG Series Gas Parts Catalog | Parts Catalog        |

# GENERAL

## INTRODUCTION

This manual is for the VMCS Heavy Duty Electric Griddle Top. Procedures in this manual will apply to all models listed on the cover page unless specified. All of the information, illustrations and specifications contained in this manual are based on the latest product information available at the time of release.

## OPERATION AND FIELD INSTALLATION

For detailed field installation, operation and cleaning instructions refer to [F47658 Operation & Field Installation Manual](#) sent with each unit. The manual is also available online at [www.vulcanequipment.com](http://www.vulcanequipment.com).

## MODELS

| Models                                                                                                                                                                                    |                                                                |
|-------------------------------------------------------------------------------------------------------------------------------------------------------------------------------------------|----------------------------------------------------------------|
| VMCS-101                                                                                                                                                                                  | *Rapid Recovery™ composite griddle plate cooking surface, 208V |
| VMCS-102                                                                                                                                                                                  | *Rapid Recovery™ composite griddle plate cooking surface, 240V |
| VMCS-201                                                                                                                                                                                  | Optional, Grooved steel griddle plate cooking surface, 208V    |
| VMCS-202                                                                                                                                                                                  | Optional, Grooved steel griddle plate cooking surface, 240V    |
| *9/16" (15mm) thick fully welded Rapid Recovery composite griddle plate (aluminum core interior with 304 Series stainless steel exterior) for fast temperature recovery and even heating. |                                                                |

## SPECIFICATIONS

| ELECTRICAL |         |        |                  |
|------------|---------|--------|------------------|
| Model      | Voltage | Power  | 1 Phase AMP Draw |
| VMCS-101   | 208V    | 3.6 kW | 17.3             |
| VMCS-102   | 240V    | 3.6 kW | 15.0             |
| VMCS-201   | 208V    | 3.6 kW | 17.3             |
| VMCS-202   | 240V    | 3.6 kW | 15.0             |

## TOOLS

- Standard set of hand tools.
- Temperature tester with surface probe.
- VOM with ability to measure micro amp current. VOM with minimum of NFPA-70E CAT III 600V, UL/CSA/TUV listed. Sensitivity of at least 20,000 ohms per volt. Meter leads must also be rated at CAT III 600V.
- Clamp on type amp meter with minimum of NFPA-70E CAT III 600V, UL/CSA/TUV listed, for measuring heating element current draw.

### Special

- Torque Wrench - Capable of measuring 20 in-lb.
- Loctite® 242™

# REMOVAL AND REPLACEMENT OF PARTS

## REMOVE CLAMSHELL FROM FRAME



### ⚠ WARNING

Disconnect the electrical power to the machine and follow lockout / tagout procedures.

### ⚠ WARNING

Ensure clamshell and griddle are cool to touch before servicing.

**NOTE:** This procedure requires two people to remove clamshell.

1. Place cardboard or other protective covering on griddle surface to prevent scratching.
2. Remove rear cover bolts.

**NOTE:** Junction box is secured to the bottom of rear cover with screws and can remain attached.

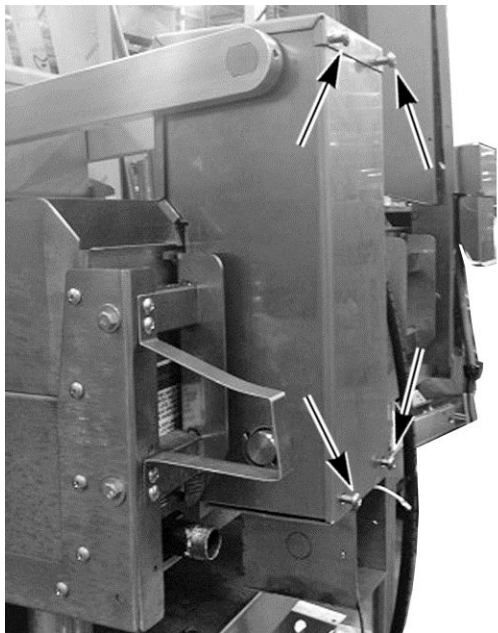

Fig. 2

28976

3. Remove rear housing lid (1, Fig. 3) and rear cover (2, Fig. 3).

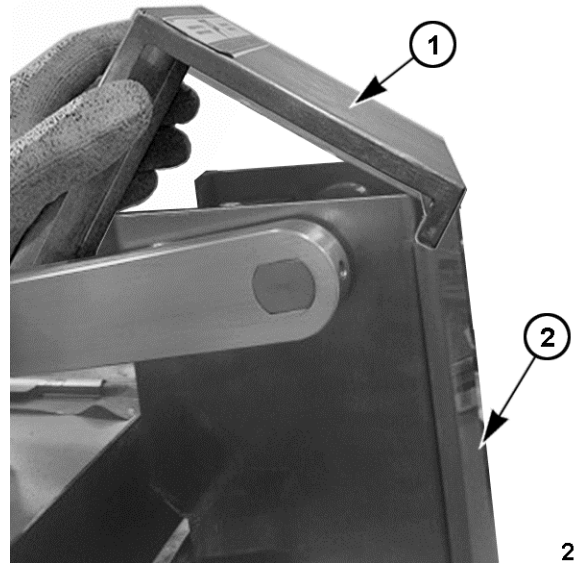

Fig. 3

28977

4. Loosen bump stop bolt (1, Fig. 4) and remove screws (2, Fig. 4) from each side that secures bump stop plate (3, Fig. 4) to rear housing.

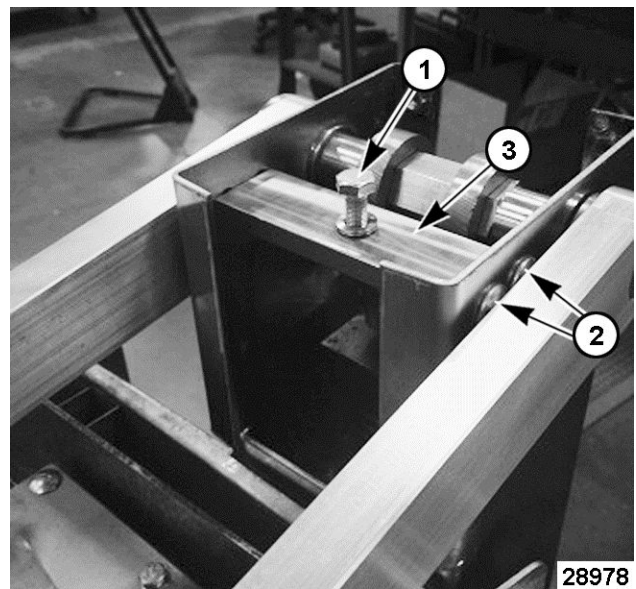
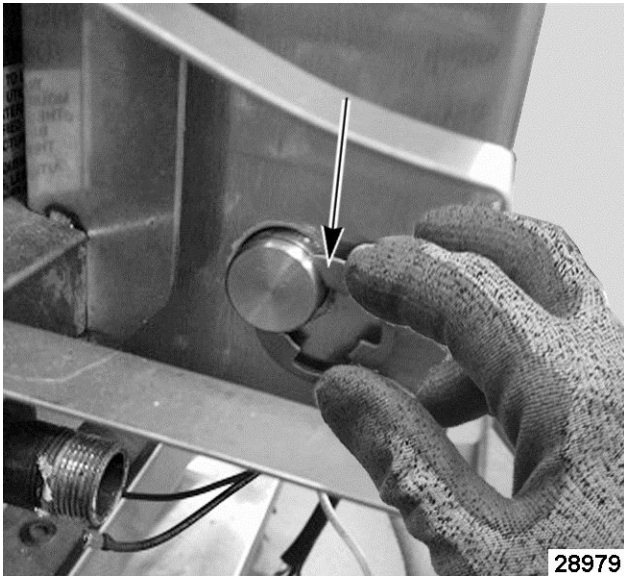

Fig. 4

28978

5. One person fully raises clamshell by the handle to remove spring force and hold in place. The other person removes all 4 retaining clips from the lower pivot rod at the rear housing.



**Fig. 5**

6. Push lower pivot rod out from the spring mount (block).
  - A. Remove spring mount (block), lower spring alignment shafts (male) and system springs.

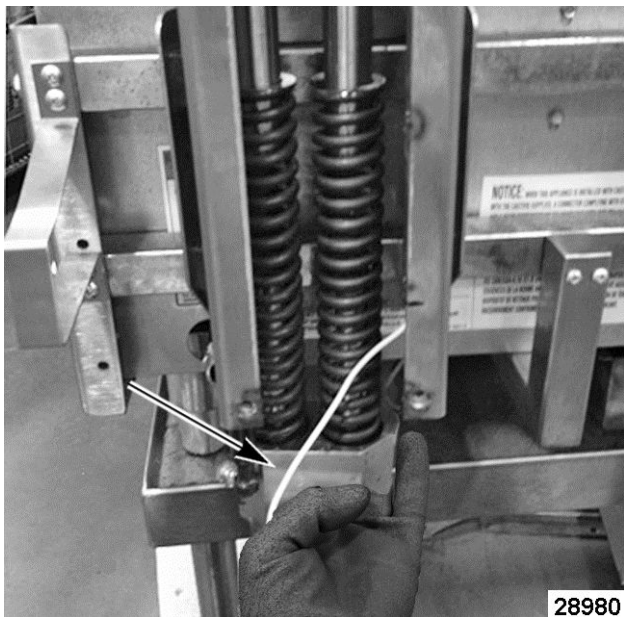

**Fig. 6**

- B. Lower clamshell onto griddle surface.
7. If removing top control box and clamshell from arms to access capillary bulbs and heating element:
  - A. Remove TOP CONTROL BOX COVER.
  - B. Note locations and disconnect power supply wires from terminal strip.

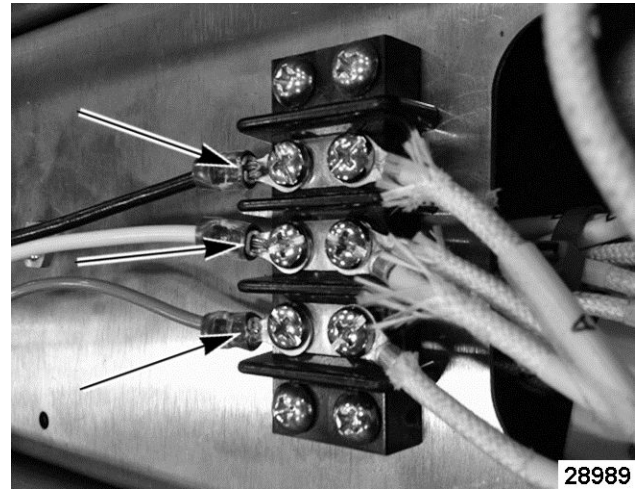

**Fig. 7**

- C. Fully raise clamshell to access the left arm wireway cover on the bottom of arm. Remove wireway cover (1, Fig. 8) from the bottom of left arm.

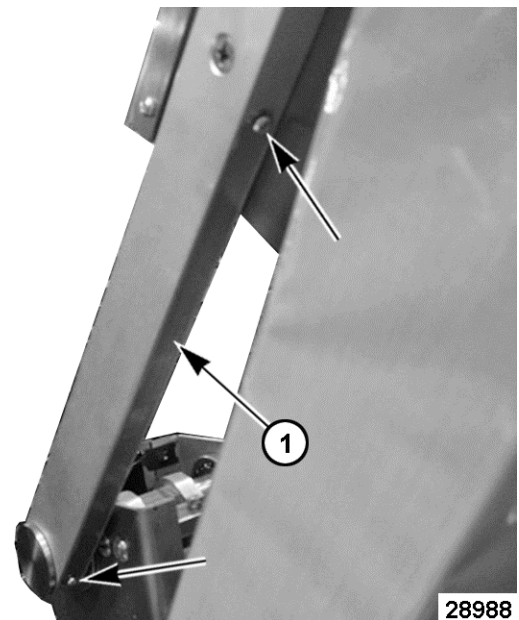

**Fig. 8**

- D. Lower clamshell and remove 4 screws on the outer side of both arms. The screws and locknuts secure the control box to the arms and the control box mounting shelf inside the box.

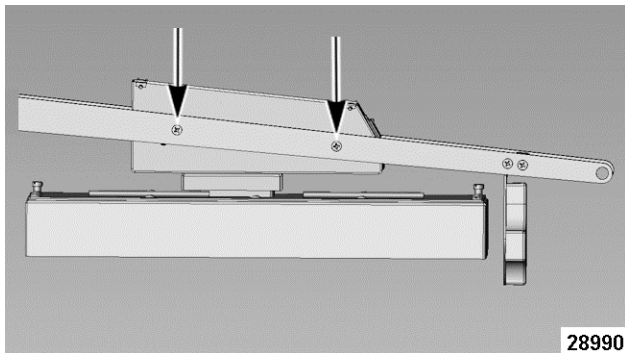

28990

**Fig. 9**

- E. Lift the control box mounting shelf (1, Fig. 10) and place to the side.
- F. Feed the power supply wires (2, Fig. 10) back into the left arm enough to clear control box.

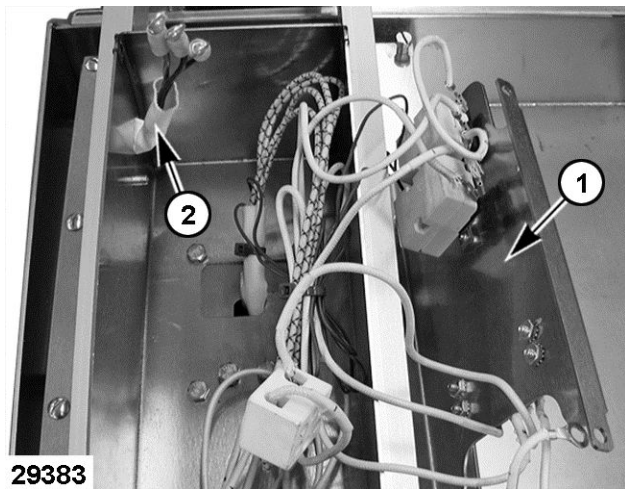

29383

**Fig. 10**

- G. Lift the arm to clear the control box then slide control box and clamshell away from the arms.
8. If completely removing clamshell and rear housing from frame:
- A. Remove bolts securing rear housing to griddle frame.

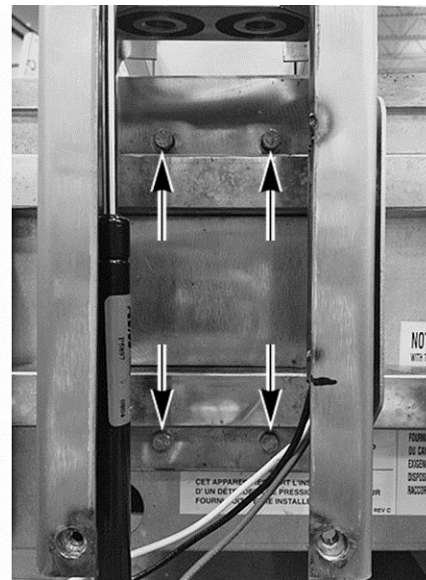

28981

**Fig. 11**

- B. Remove clamshell from frame.
9. Reverse procedure to install.
10. Check for proper operation.

**TOP CONTROL BOX COVER**



**WARNING**

Disconnect the electrical power to the machine and follow lockout / tagout procedures.

- 1. Remove top control box cover.

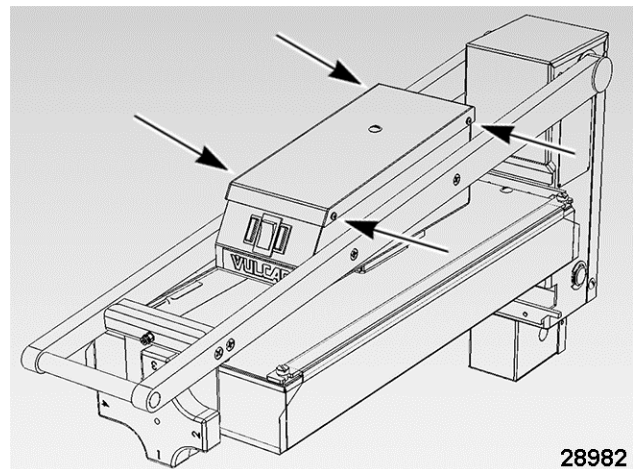

28982

**Fig. 12**

- 2. Remove wiring cover plate to access electrical components.



Fig. 13

3. Reverse procedure to install.

### POWER SWITCH



#### ⚠ WARNING

Disconnect the electrical power to the machine and follow lockout / tagout procedures.

1. Remove TOP CONTROL BOX COVER.
2. Note wire locations and disconnect from switch (1).

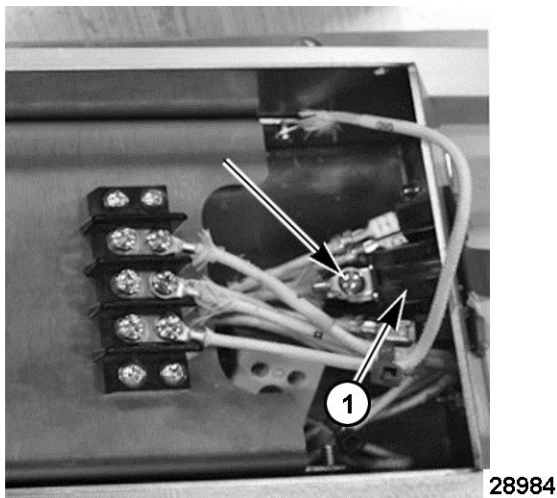

3. Pinch retaining clips and push switch (1) through the opening.

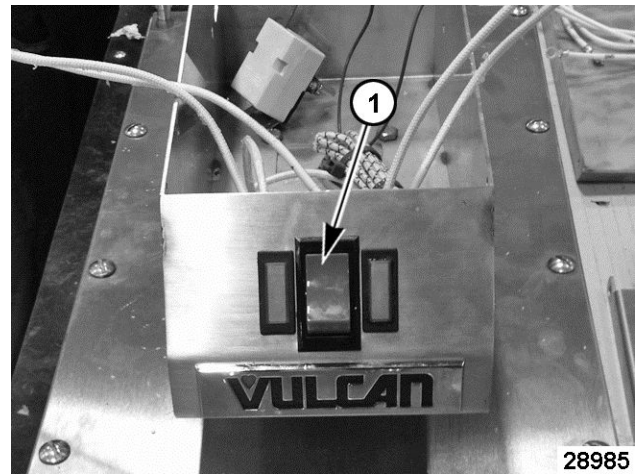

Fig. 15

4. Reverse procedure to install.

**NOTE:** Ensure that terminal connections are completely seated and tight.

5. Check for proper operation.

### REMOVE HEATING SECTION FROM HANDLE ARMS



#### ⚠ WARNING

Disconnect the electrical power to the machine and follow lockout / tagout procedures.

1. Remove upper cover (1, Fig. 16) from rear assembly.



Fig. 16

**⚠ WARNING**

Arm is under tension, this procedure is preventing arm from moving when platen is removed.

- Remove bump-stop bracket mounting screws.

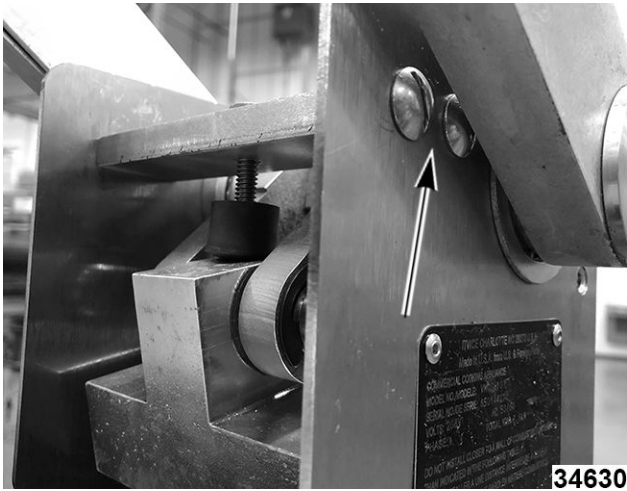

Fig. 17

- Remove bump stop and bolt from bracket.

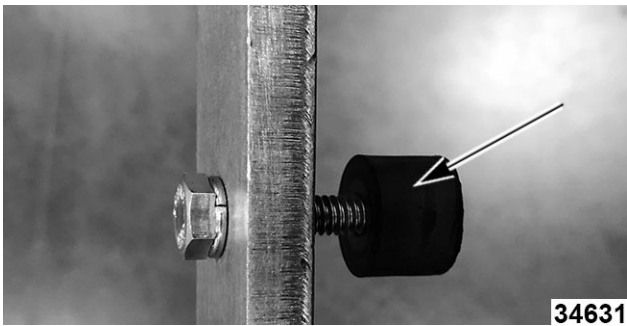

Fig. 18

- Insert bump-stop bracket between upper spring block and pitman arm shaft.

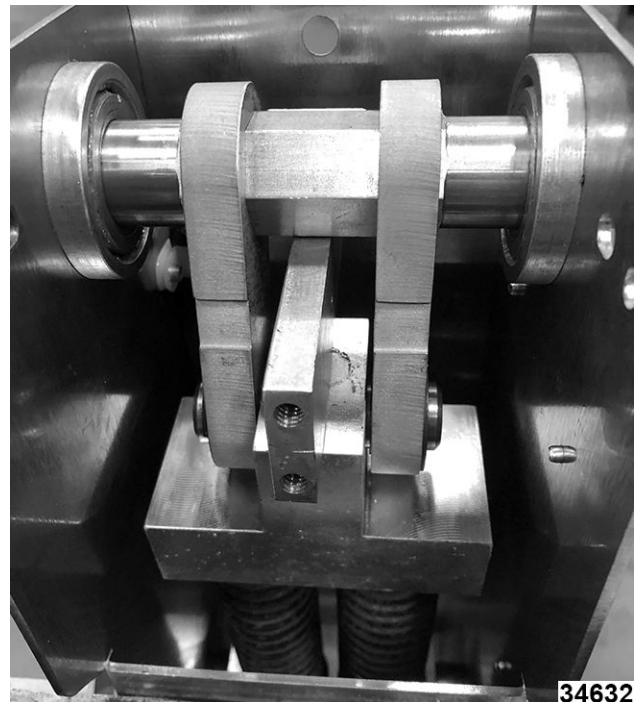

Fig. 19

**NOTE:** A 5/16" hole must be drilled in the cover if this is the first time this procedure has been done on this unit.

- Drill 5/16" inch hole 2" inches from edge of cover as shown in Fig. 20.

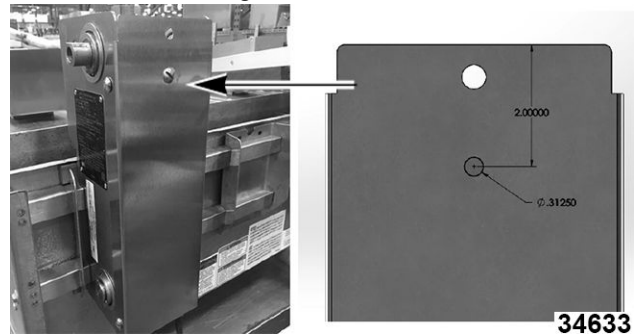

Fig. 20

- Secure bracket by threading one mounting screw back into bracket (1, Fig. 21) through rear of cover.

**TOP VIEW SHOWN IN Fig. 21**

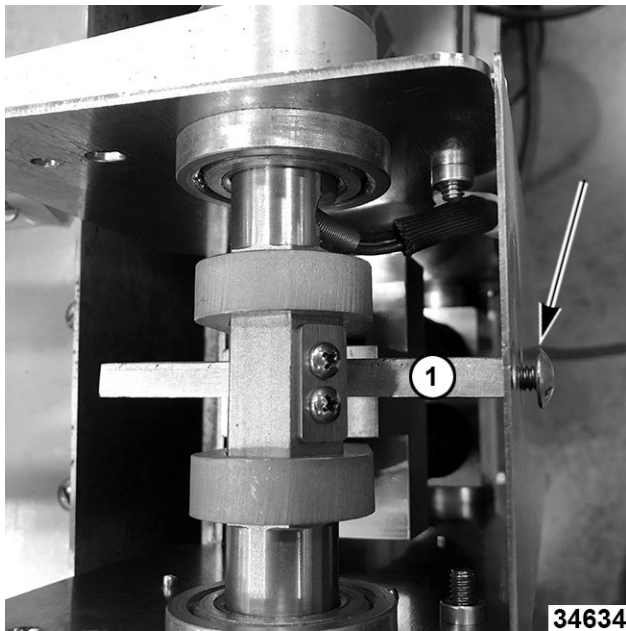

Fig. 21

7. Remove incoming power wire cover (1, Fig. 22).



Fig. 22

8. Disconnect incoming power wiring (1, Fig. 23) from terminal block.

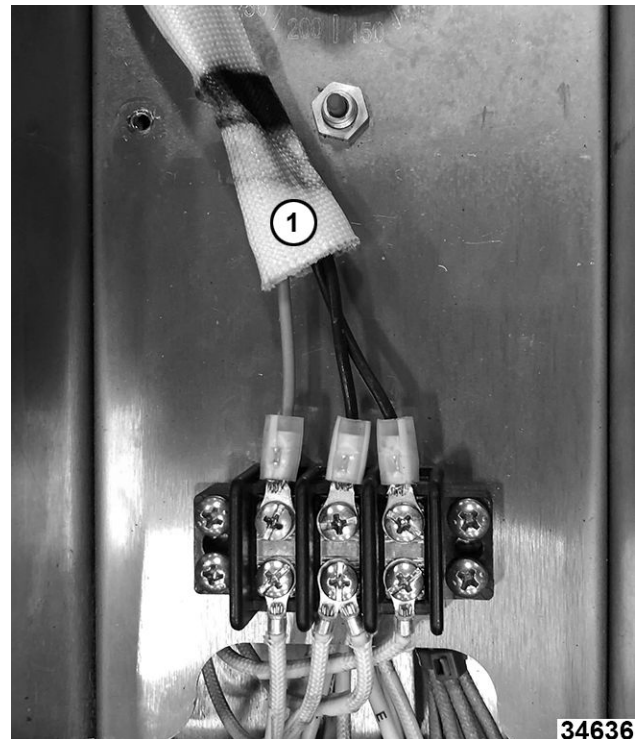

Fig. 23

9. Remove right-side arm (1, Fig. 24) mounting screws and retainer. Remove arm from unit.



Fig. 24

10. Remove remaining control box (1, Fig. 25) mounting screws from left side.



Fig. 25

- Carefully remove wiring (1, Fig. 26) out of control box.

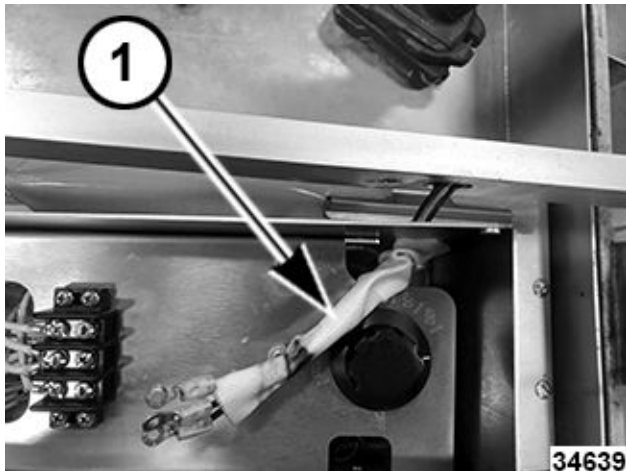

Fig. 26

- Remove platen and control box for service access to griddle.



Fig. 27

- Reverse procedure to install.

**NOTICE**

Verify power wire sleeve passes through sheet metal into the arm.

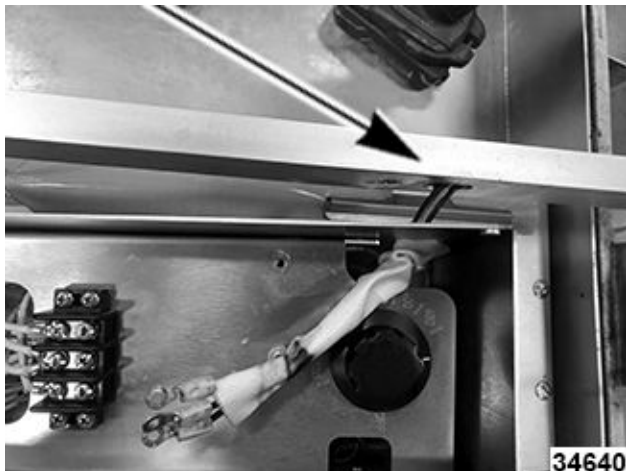

Fig. 28

- Verify proper operation.

**INDICATOR LIGHTS**



**WARNING**

Disconnect the electrical power to the machine and follow lockout / tagout procedures.

- Remove TOP CONTROL BOX COVER.
- Note wire locations and disconnect from light (1) being replaced.

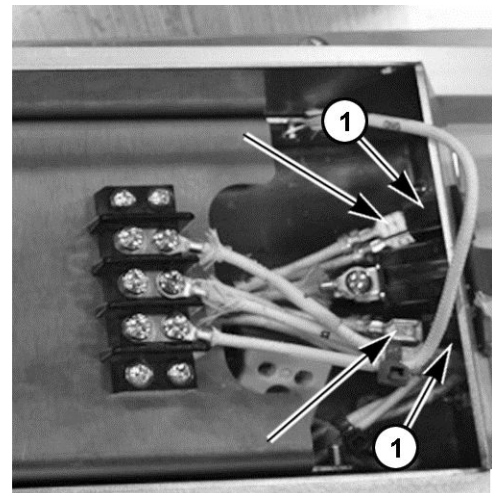

Fig. 29

- Pinch retaining clips and push light (1) through the opening.

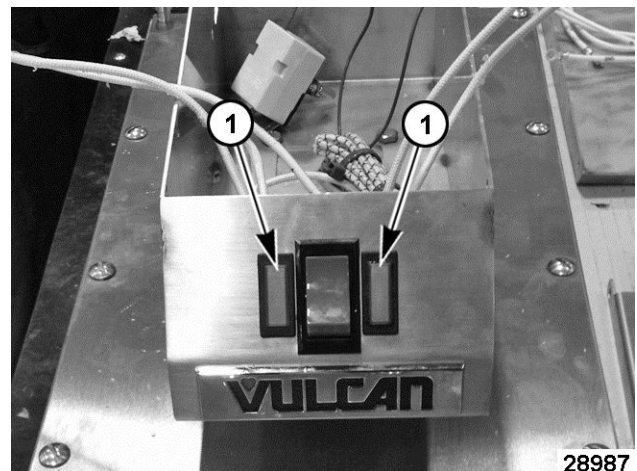

Fig. 30

- Reverse procedure to install.

**NOTE:** Ensure that terminal connections are completely seated and tight.

- Check for proper operation.

## POWER CORD

1. Remove TOP CONTROL BOX COVER.
2. Remove rear housing lid as outlined under REMOVE CLAMSHELL FROM FRAME.
3. Fully raise platen to access the left arm wireway cover (1, Fig. 31) then remove the cover.

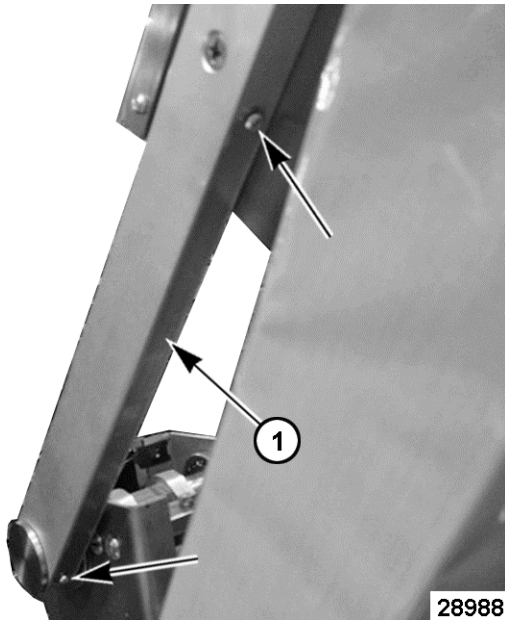

**Fig. 31**

4. Note power cord wire locations and disconnect from terminal strip.

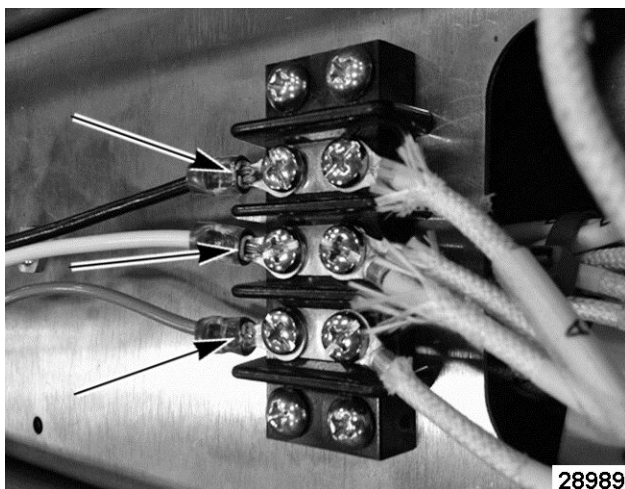
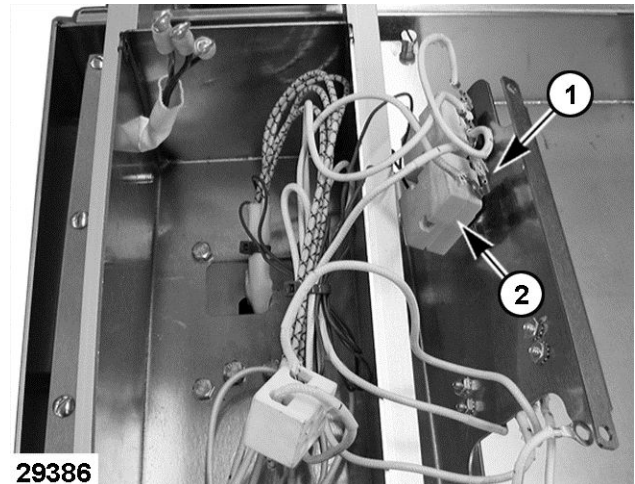

**Fig. 32**

5. Pull wire out from the left arm wire way, through grommet in top control box, through the upper pivot rod, through rear housing wire path tube (vertical) to remove from machine.
6. Reverse procedure to install.
7. Check for proper operation.

## HIGH LIMIT

1. REMOVE CLAMSHELL FROM FRAME.
2. Note wire locations (1, Fig. 33) and disconnect from high limit (2, Fig. 33).



**Fig. 33**

3. Remove mounting nut (1, Fig. 34) securing high limit to control box mounting shelf.
4. Access high limit capillary bulb:
  - A. Note wire tie locations and remove from capillary tube and wire bundle.
  - B. Note heating element wire locations (2, Fig. 34) and disconnect from terminal strip.

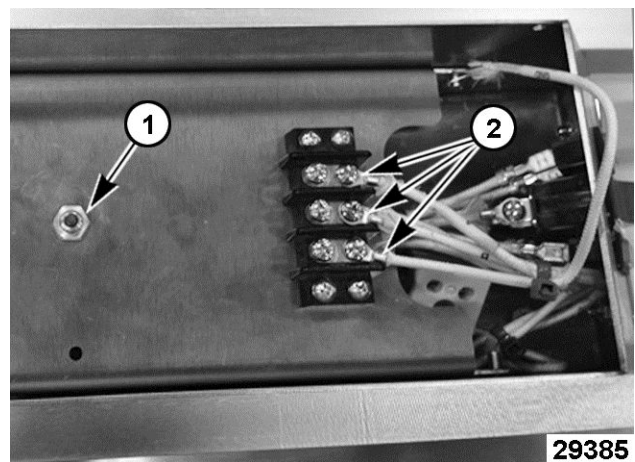

**Fig. 34**

- C. Remove 12 screws (1, Fig. 35) securing platen cover assembly (2, Fig. 35) to clamshell assembly.

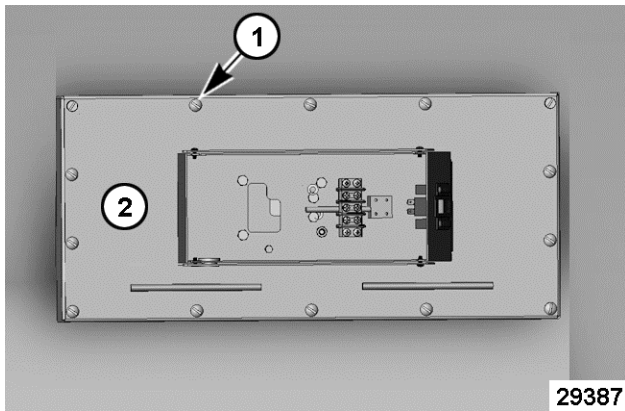

Fig. 35

- D. Remove mounting clips (1, Fig. 36) securing high limit capillary bulb to platen insulation retainer (2, Fig. 36).

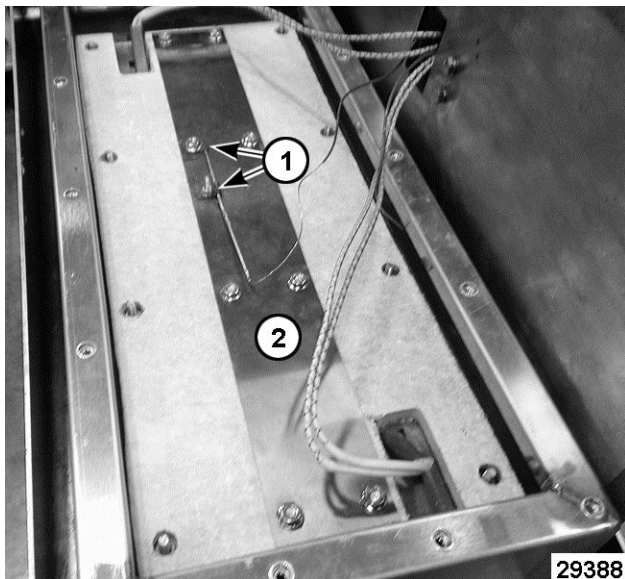

Fig. 36

5. Reverse procedure to install.

**NOTICE**

When installing, do not bend and kink the capillary tube or damage to the control may occur.

6. Check for proper operation.

**CONTROL THERMOSTAT**



**WARNING**

Disconnect the electrical power to the machine and follow lockout / tagout procedures.

1. REMOVE CLAMSHELL FROM FRAME .

2. Remove control thermostat knob and remove 2 screws securing thermostat to control box mounting shelf.

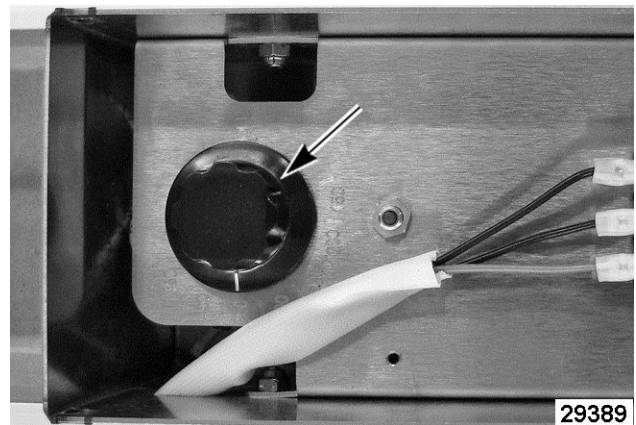

Fig. 37

3. Note wire locations (1, Fig. 38) and disconnect from control thermostat (2, Fig. 38).

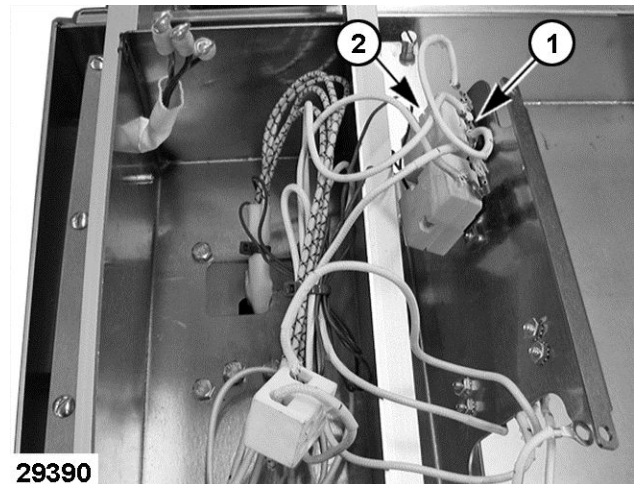

Fig. 38

4. Access control thermostat capillary bulb:  
 A. Note wire tie locations and remove from capillary tube and wire bundle.  
 B. Note heating element wire locations (1, Fig. 39) and disconnect from terminal strip.

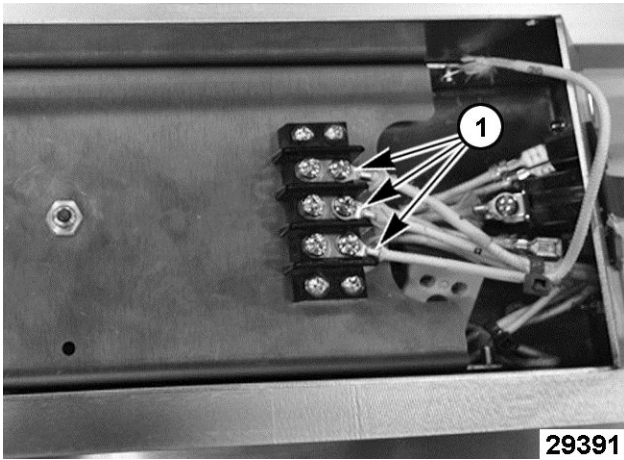

Fig. 39

5. Remove 12 screws (1, Fig. 40) securing platen cover assembly (2, Fig. 40) to clamshell assembly.

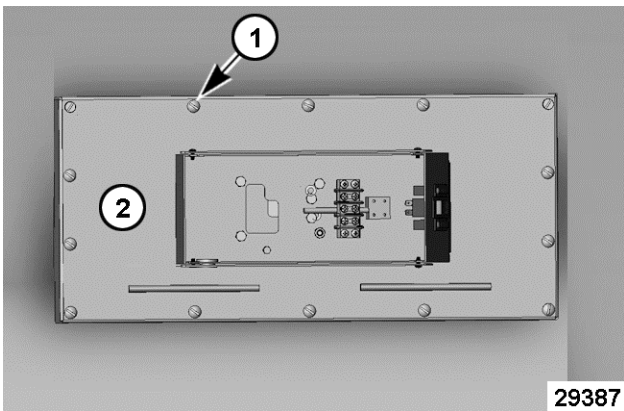

Fig. 40

6. Remove 2 mounting nuts and clips (1, Fig. 41) securing high limit capillary bulb to platen insulation retainer (2, Fig. 41).

**NOTICE**

Do not bend and kink the capillary tube or damage to the control may occur.

- A. Position capillary bulb to the side.

7. Remove the remaining 7 mounting nuts (3, Fig. 41) from platen insulation retainer.

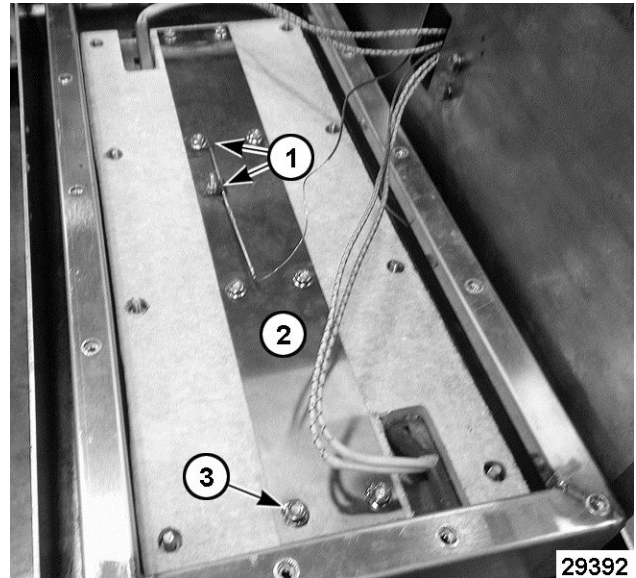

Fig. 41

8. Lift platen insulation and retainer from clamshell.
9. Remove 16 mounting nuts (1, Fig. 42) securing heating element retainer (2, Fig. 42) to platen.

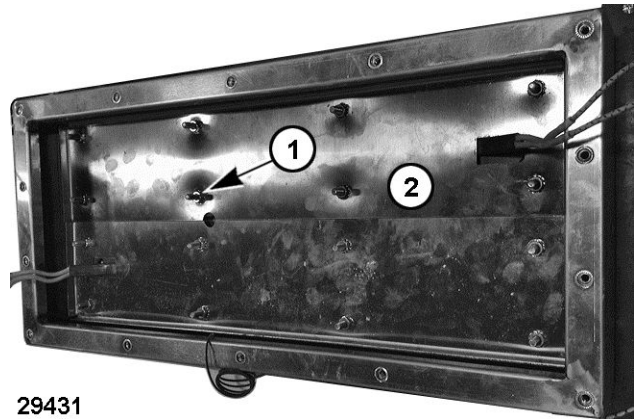

Fig. 42

10. Lift heating elements off platen to access thermostat capillary bulb.

- A. Remove thermostat capillary bulb and thermostat from clamshell assembly.

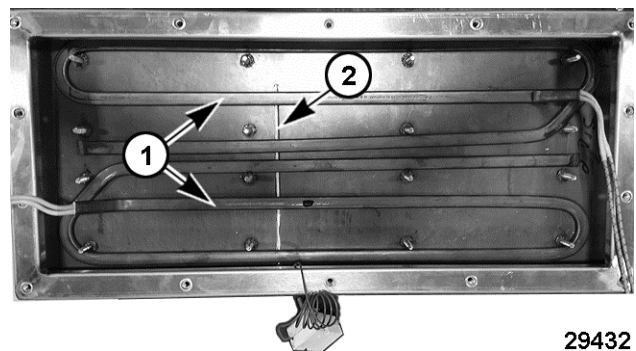

Fig. 43

11. Reverse procedure to install.
12. Check for proper operation.

## HEATING ELEMENTS



### ⚠ WARNING

**Disconnect the electrical power to the machine and follow lockout / tagout procedures.**

1. REMOVE CLAMSHELL FROM FRAME .
2. Note wire tie locations and remove from capillary tube and wire bundle.
3. Note heating element wire locations (1, Fig. 44) and disconnect from terminal strip.

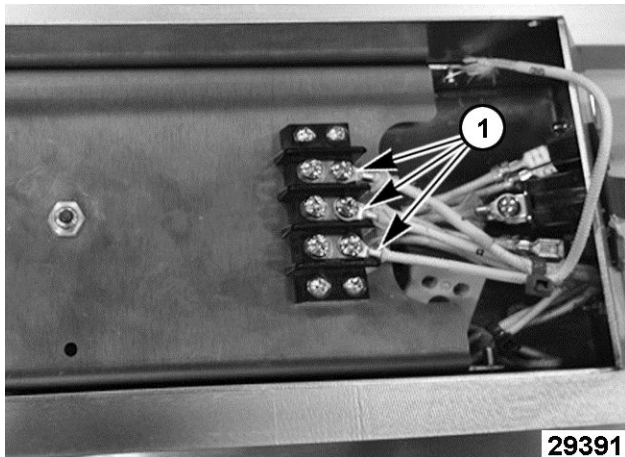

**Fig. 44**

4. Remove 12 screw (1, Fig. 45) securing platen cover assembly (2, Fig. 45) to clamshell assembly.

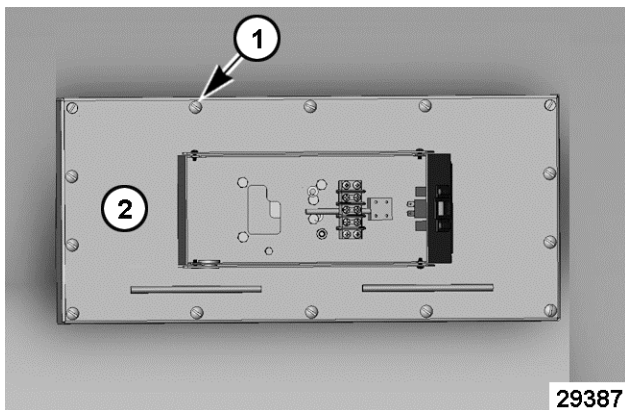

**Fig. 45**

5. Remove mounting clips (1, Fig. 46) securing high limit capillary bulb to platen insulation retainer (2, Fig. 46).

### NOTICE

Do not bend and kink the capillary tube or damage to the control may occur.

A. Position capillary bulb to the side.

6. Remove the remaining 7 mounting nuts (3, Fig. 46) from platen insulation retainer.

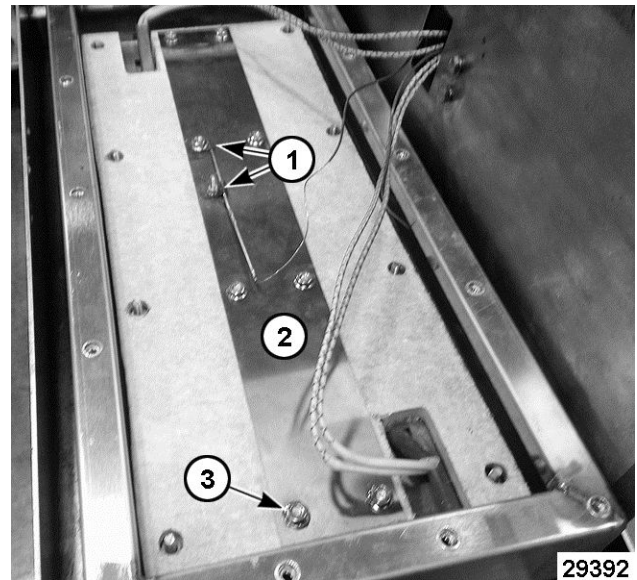

**Fig. 46**

7. Lift platen insulation and retainer from clamshell.
8. Remove 16 mounting nuts (1, Fig. 47) securing heating element retainer (2, Fig. 47) to platen.

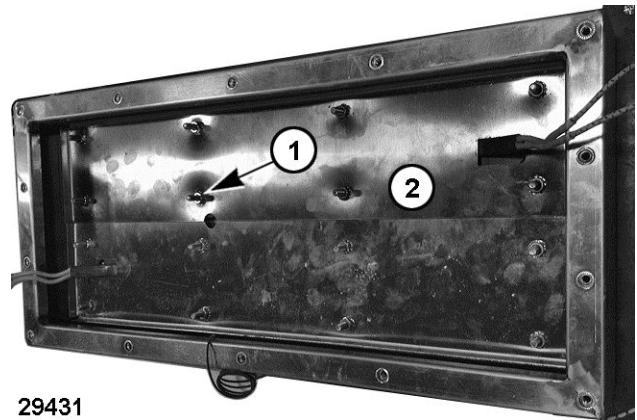

**Fig. 47**

9. Lift heating elements off the platen.
10. Reverse procedure to install.
11. Check for proper operation.

**NOTE:** When installing heating elements, torque mounting nuts to 20 in-lb.

**NOTE:** When installing platen insulation, hand tighten mounting nuts plus 1/2 turn to secure.

## ARM MECHANISM



### ⚠ WARNING

Disconnect the electrical power to the machine and follow lockout / tagout procedures.

1. Remove springs from rear housing to release system tension as outlined under REMOVE CLAMSHELL FROM FRAME.
2. Remove TOP CONTROL BOX COVER.
3. If removing left arm:
  - A. Note locations and disconnect power supply wires from terminal strip.

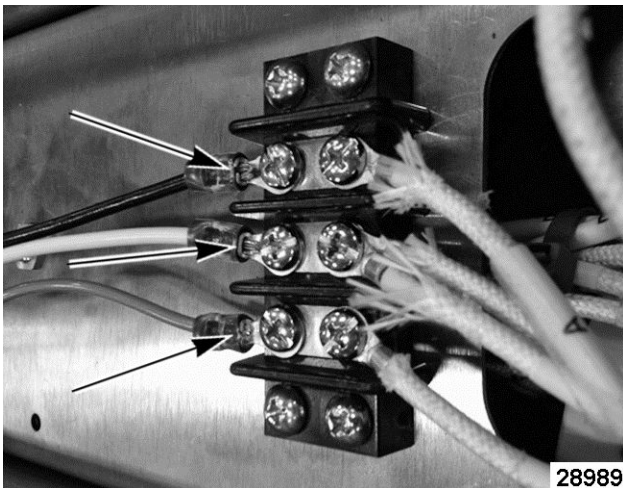

Fig. 48

- B. Fully raise clamshell to access the left arm wireway cover on the bottom of arm. Remove wireway cover (1, Fig. 49) from the bottom of left arm.

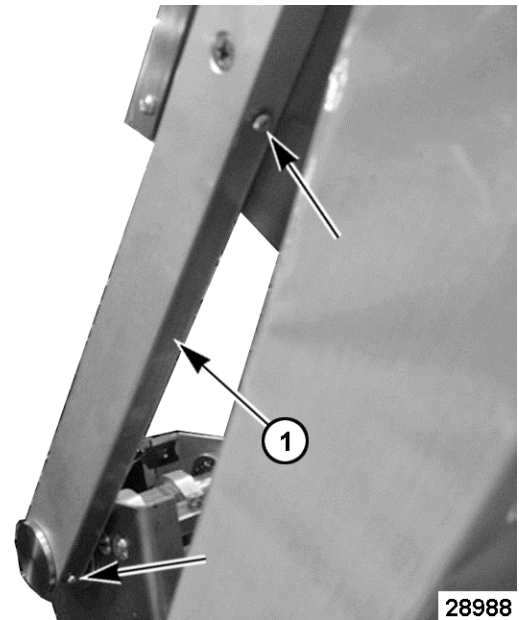

Fig. 49

- C. Lower clamshell.
  - D. Feed the power supply wires back into the arm enough to clear the control box.

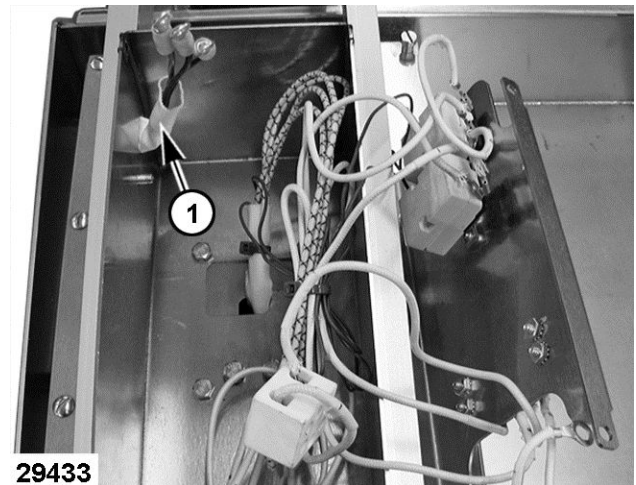
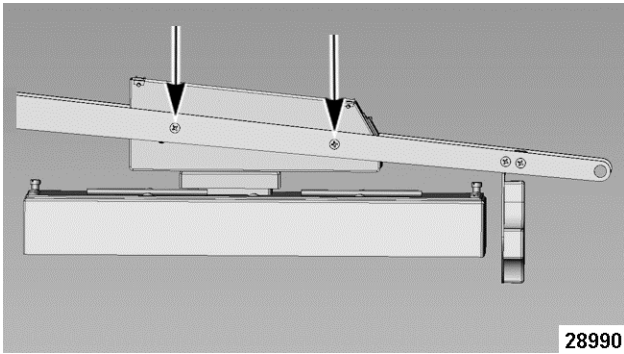

Fig. 50

4. Remove 2 screws on the outer side of the arm being replaced. The screws and locknuts secure the control box to the arm and the control box mounting shelf inside the box.



**Fig. 51**

5. Remove cap from arm being replaced (cap is threaded).

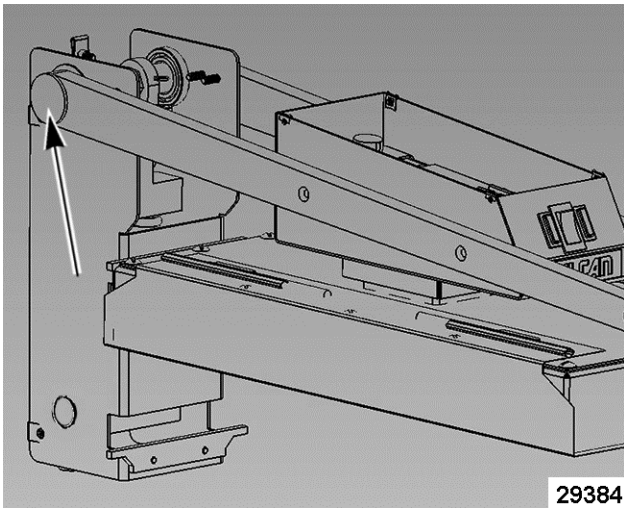

**Fig. 52**

6. Pull arm straight off the upper pivot rod.

**NOTE:** The arm handle is a loose fit between the arms and will fall away when either arm is removed.

7. Reverse procedure to install.
8. Check for proper operation.

# SERVICE PROCEDURES AND ADJUSTMENTS



## ⚠ WARNING

Certain procedures in this section require electrical test or measurements while power is applied to the machine. Exercise extreme caution at all times and follow Arc Flash procedures. If test points are not easily accessible, disconnect power and follow Lockout/Tagout procedures, attach test equipment and reapply power to test.

## GRIDDLE TOP MANUAL LIFT CHECK

### ⚠ WARNING

Always hold handle to maintain control of the unit until lifting mechanism holds in the desired raised position or rests in the lowered position. Do not allow unit to swing upward or downward under its own power as this may result in injury or equipment damage.

### NOTICE

Do not force unit if it does not move up and down in the prescribed manner. The assembly may be damaged by the application of excessive upward or downward force.

**NOTE:** A spring force adjustment is not provided on this unit. It's designed to apply a consistent downward force on the food product regardless of thickness. Use the PLATE GAP ADJUSTER to prevent crushing of soft foods by the downward force of the unit.

Perform this procedure to manually check the raising and lowering operation of the griddle top.

1. Grasp the handle Fig. 53 and raise unit (1, Fig. 54) to its maximum height of approximately 53 angular degrees then stop.

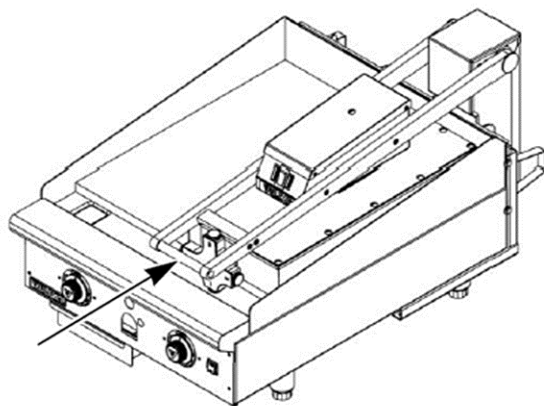

28975

Fig. 53

2. Release the handle and verify unit remains in place.
3. Grasp the handle and lower the unit (2, Fig. 54) until it contacts griddle cooking surface.

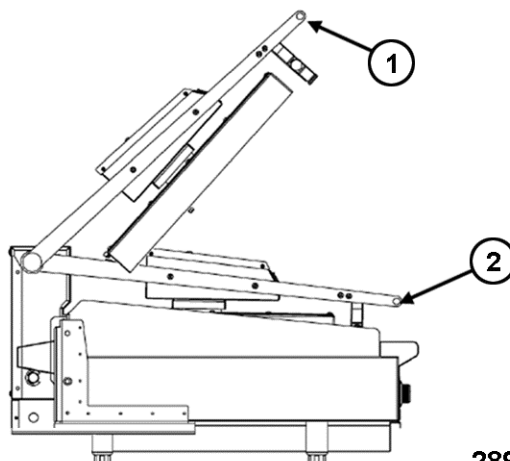

28973

Fig. 54

4. If the lifting operation was smooth without binding or catching and remained in place at the raised position then servicing is not necessary. If the lifting operation was binding and catching then inspect the lifting mechanism for damaged, loose or missing hardware and service to repair as necessary.

## PLATE GAP ADJUSTER

The plate gap adjuster (1, Fig. 55) is used to prevent soft foods from being crushed by the downward force of the unit. The 1" setting would be used for the smallest or no gap with 4" being used to create the largest gap.

Settings are changed by rotating the gap adjuster to the left or right until it locks in place at the desired gap setting.

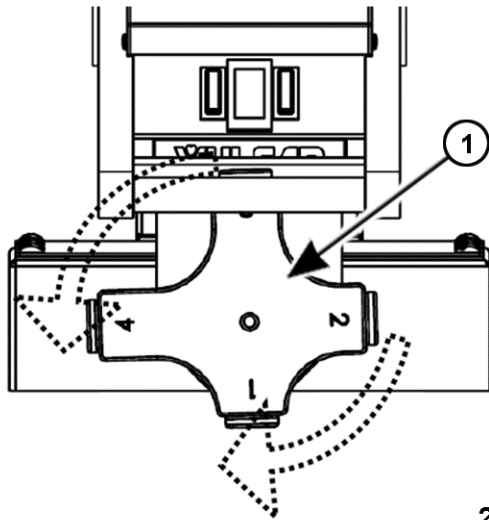

28972

Fig. 55

**THERMOSTAT TEST**

1. Position temperature tester probe in center of griddle top plate, 8" down from the top edge.
2. Turn griddle top on and set to 350°F. Allow thermostat to cycle 3 times to preheat.
3. Record temperature when indicator light turns ON and OFF. Repeat for 3 cycles.
4. Calculate the temperature differential.

Differential = Indicator Light OFF - Indicator Light ON

*Example:* 365 - 340 = 25°F differential

- A. Differential should be less than 50°F.
- B. If differential is greater than 50°F, replace control thermostat.

5. Calculate the average temperature.

Average Temperature =

Indicator Light OFF + Indicator Light ON

2

*Example:* 365 + 345 = 710 ÷ 2 = 355°F

6. If average temperature differs more than 50°F from the dial setting, replace thermostat.

**HEATING ELEMENT TEST**

1. Measure voltage at heating element leads and verify against data plate voltage.
  - A. If voltage is incorrect, find the source of the problem.

- B. If voltage is correct, check current draw (amps) through the heating element lead wires.

**NOTE:** This method is preferred over a resistance check when a clamp on type amp meter is available.

2. If current draw is correct then heating element is functioning properly.

See following table for proper values.

3. If current draw is not correct, turn griddle top OFF and disconnect the electrical supply.

- A. Replace heating element then proceed to step 5.

4. If unable to check current draw, a resistance check may indicate a malfunctioning element.

- A. Disconnect electrical supply and remove lead wires from heating element. Check resistance (ohms).

See following table for proper values.

5. Check for proper operation.

| VOLTS         | POWER                                                                                                             | AMPS | OHMS |
|---------------|-------------------------------------------------------------------------------------------------------------------|------|------|
| 208           | 3.6 kW                                                                                                            | 17.3 | 12   |
| 240           | 3.6 kW                                                                                                            | 15   | 16   |
| <b>NOTES:</b> | 1. Values in table are nominal. Tolerance is +5/-10%.<br>2. Resistance values (ohms) are @ 77°F room temperature. |      |      |

# ELECTRICAL OPERATION

## COMPONENT LOCATION

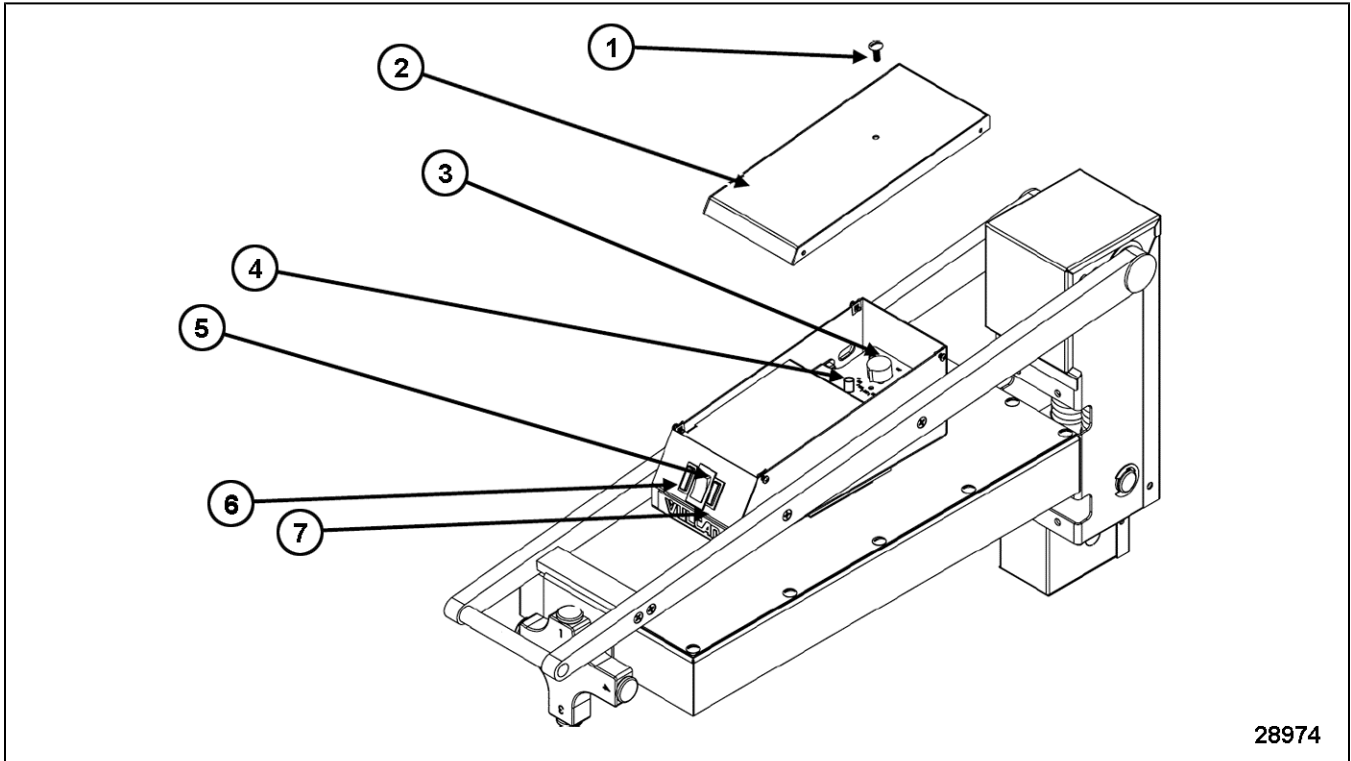

| ITEM NO. | DESCRIPTION                    |
|----------|--------------------------------|
| 1        | High Limit Reset - Access Plug |
| 2        | Thermostat Cover               |
| 3        | Thermostat Adjustment Knob     |
| 4        | High Limit Reset Button        |
| 5        | Power Switch                   |
| 6        | Power Light (Amber)            |
| 7        | Heating Light (Amber)          |

## COMPONENT FUNCTION

- Power Switch** ..... Power switch turns griddle top ON and OFF.
- Indicator Light (Power)** ..... Left amber light indicates when power switch is turned ON.
- Indicator Light (Thermostat)** ..... Right amber light indicates when thermostat is calling for heat.
- Thermostat** ..... Monitors temperature of griddle top and cycles power to heating element.

**High Limit** . . . . . Protects griddle top by cutting power to heating element if temperature goes above 624°F. A manual reset device (after cool down).

**Heating Element** . . . . . Heat source for griddle top.

**WIRING DIAGRAM**

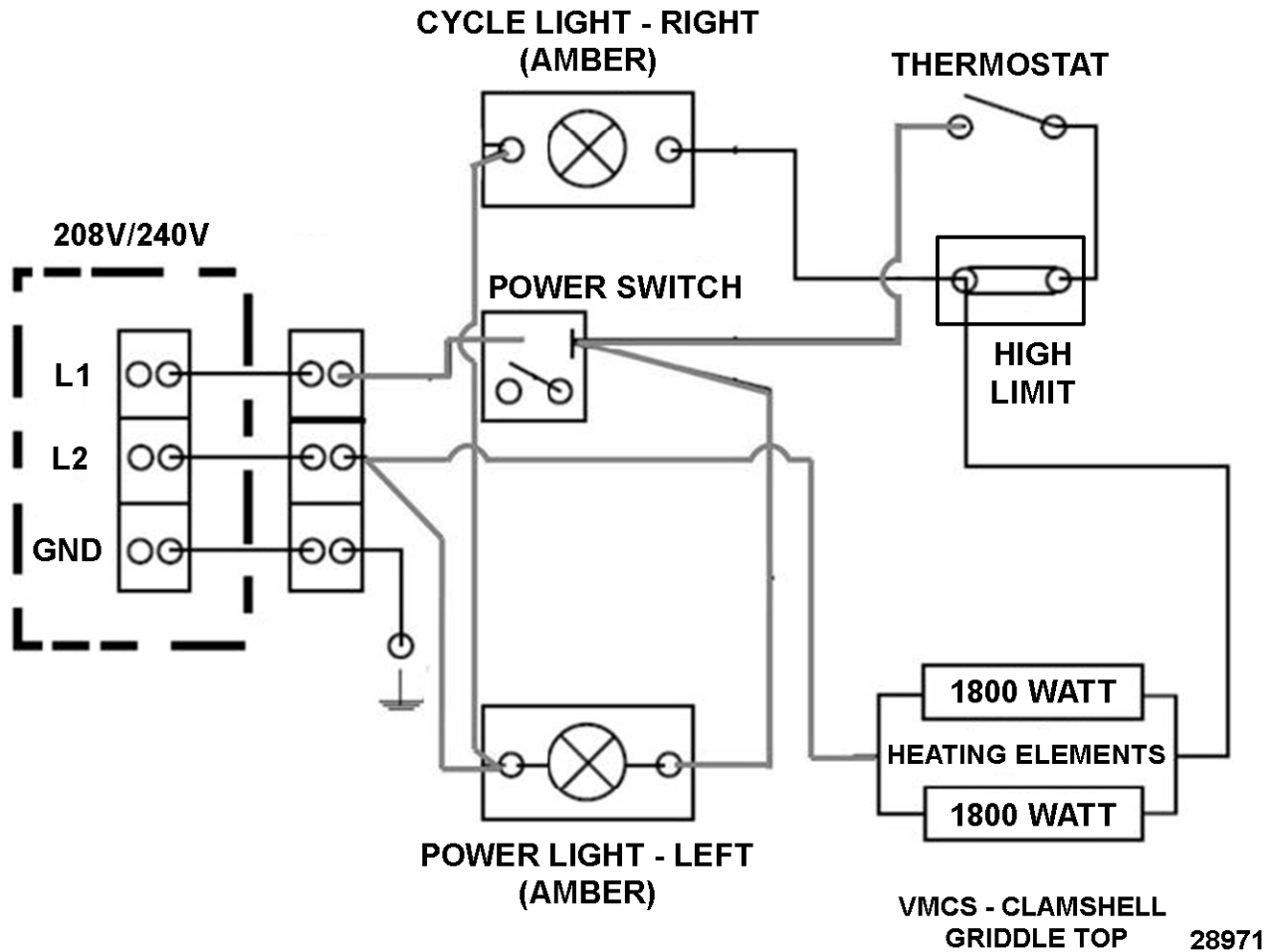

Fig. 57

# TROUBLESHOOTING

## TROUBLESHOOTING

| SYMPTOM                                                                         | POSSIBLE CAUSE                                                                                                                                                                                                                                                                                                                                                    |
|---------------------------------------------------------------------------------|-------------------------------------------------------------------------------------------------------------------------------------------------------------------------------------------------------------------------------------------------------------------------------------------------------------------------------------------------------------------|
| Heat does not come on when power switch is turned ON.<br>(Amber Power Light ON) | <ol style="list-style-type: none"> <li>1. Thermostat set too low for current griddle temperature.</li> <li>2. High limit tripped - Press reset button (after cool down).</li> <li>3. High limit malfunction.</li> <li>4. Power switch malfunction.</li> <li>5. Thermostat malfunction.</li> <li>6. Heating element malfunction.</li> </ol>                        |
| Heat does not come on when thermostat is turned ON.<br>(Amber Heat Light OFF)   | <ol style="list-style-type: none"> <li>1. Power switch not in the ON position.</li> <li>2. High limit tripped - Press reset button (after cool down).</li> <li>3. Power not supplied to unit.</li> <li>4. Check wiring connections.</li> <li>5. Power switch malfunction.</li> <li>6. Thermostat malfunction.</li> <li>7. Heating element malfunction.</li> </ol> |
| Unit will not <i>raise</i> or <i>lower</i> .                                    | <ol style="list-style-type: none"> <li>1. Check spring mechanism and look for interference.</li> </ol>                                                                                                                                                                                                                                                            |
| Food under-cooked.                                                              | <ol style="list-style-type: none"> <li>1. Temperature set too low.</li> <li>2. Food not cooked long enough. See <u>Operation &amp; Field Installation Manual</u>.</li> <li>3. Cooking surface not touching or partially touching food when in the lowered position. Turn <u>PLATE GAP ADJUSTER</u> to a lower setting.</li> </ol>                                 |
| Food over-cooked.                                                               | <ol style="list-style-type: none"> <li>1. Temperature set too high.</li> <li>2. Food cooked too long. See <u>Operation &amp; Field Installation Manual</u>.</li> <li>3. Cooking surface pressing down too hard when in the lowered position. Turn <u>PLATE GAP ADJUSTER</u> to a higher setting.</li> </ol>                                                       |
| Food is being crushed.                                                          | <ol style="list-style-type: none"> <li>1. Cooking surface pressing down too hard when in the lowered position. Turn <u>PLATE GAP ADJUSTER</u> to a higher setting.</li> </ol>                                                                                                                                                                                     |

| SYMPTOM                         | POSSIBLE CAUSE                                                                                                                                                                                                                                                                                                          |
|---------------------------------|-------------------------------------------------------------------------------------------------------------------------------------------------------------------------------------------------------------------------------------------------------------------------------------------------------------------------|
| Food sticks to cooking surface. | <ol style="list-style-type: none"> <li>1. Temperature set too high or too low.</li> <li>2. Cooking surface needs to be cleaned. See <a href="#">Operation &amp; Field Installation Manual</a>.</li> <li>3. Cooking surface not covered with enough cooking oil.</li> <li>4. Cooking surface worn or damaged.</li> </ol> |