

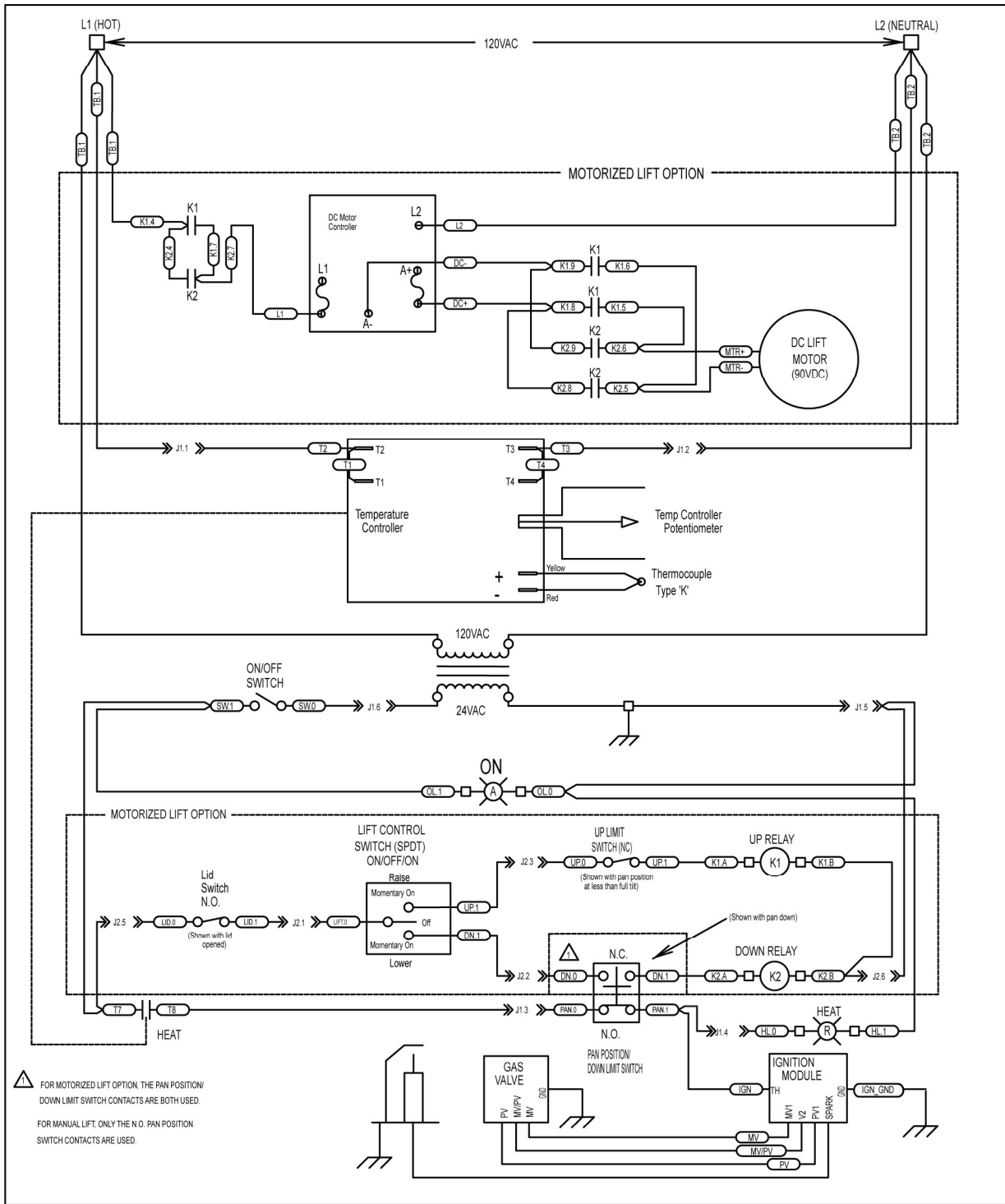

VG GAS BRAISING PANS (30 & 40 GALLON) - ELECTRICAL OPERATION



DERIVED FROM 00-854710-00001 REV H

AI4983

2ND GENERATION CYRDOM TEMPERATURE CONTROLLER - HONEYWELL IGNITION CONTROL MODULE

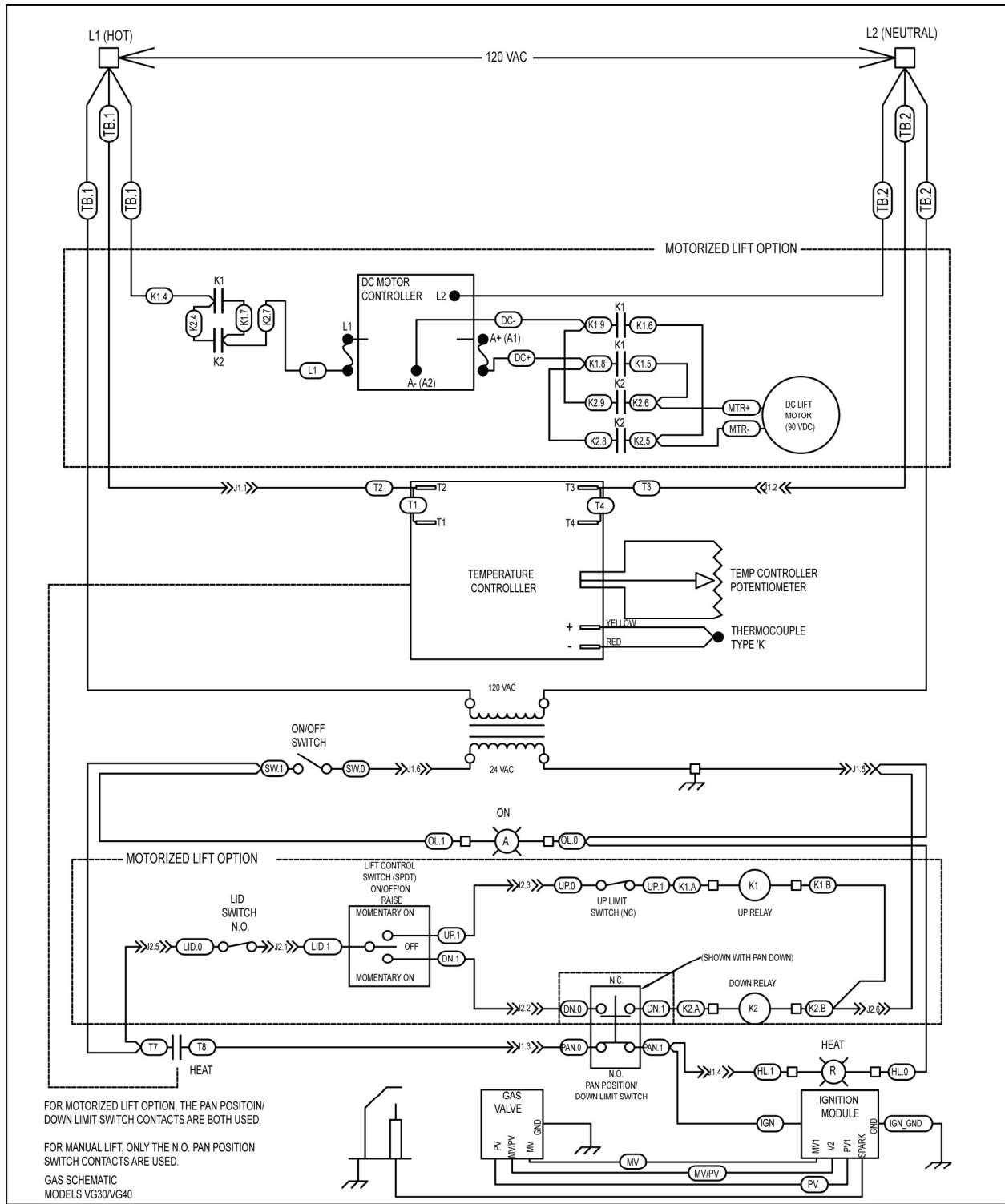

DERIVED FROM 00-854710-0001 REV I

A14981

2ND GENERATION CYRDOMTEMPERATURE CONTROLLER - FENWELL IGNITION CONTROL MODULE

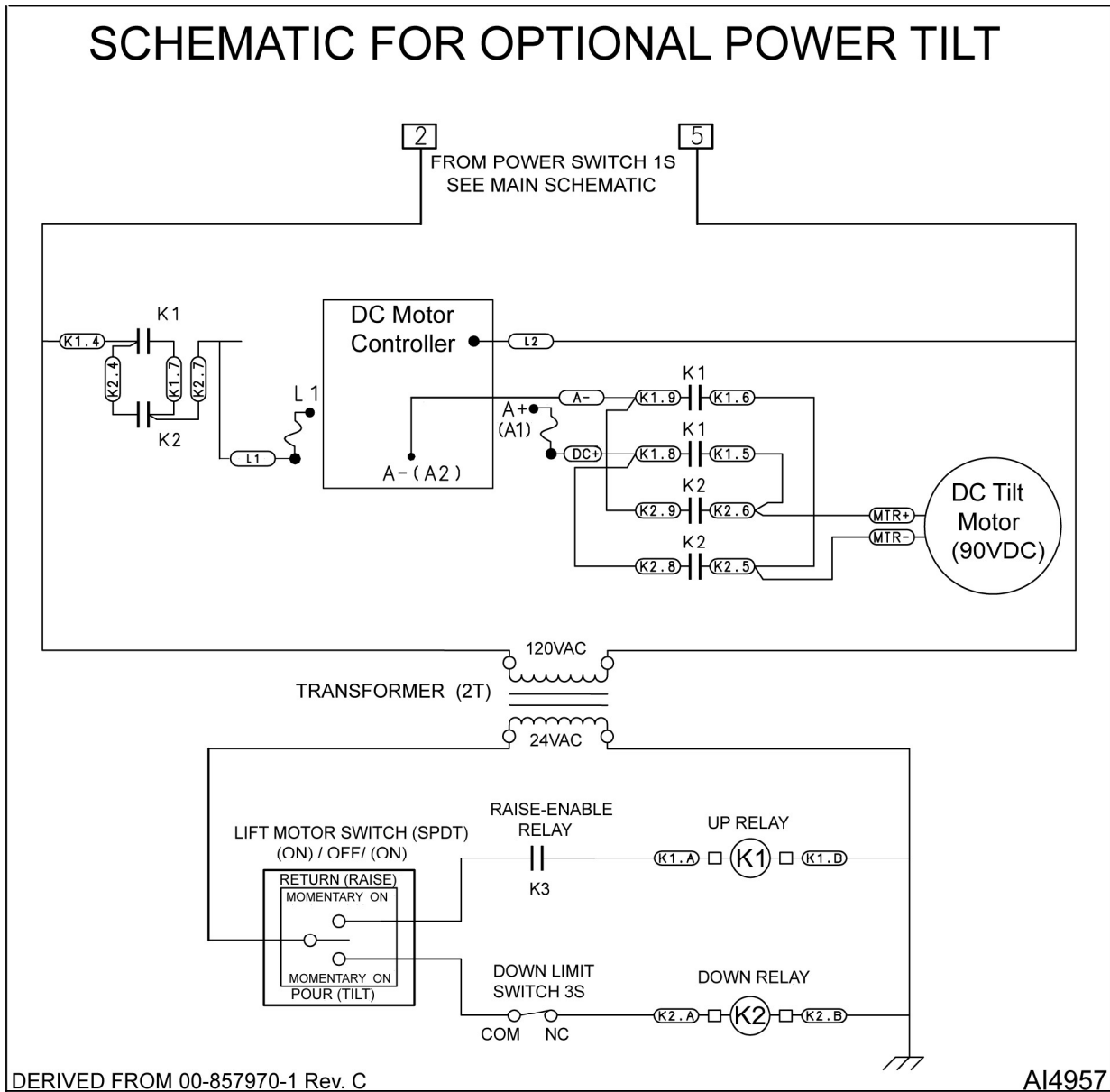

Fig. 83