



## V SERIES HDR GAS RANGES

### TOPS

Open Top  
Hot Top  
Griddle Top  
Work Surface

### BASES

Standard Oven  
Convection Oven  
Cabinet Base

\*Add "B" for Cabinet Base.

\*Add "S" for Standard Oven Base on 36" Models.

\*Add "C" for Convection Oven Base on 36" Models.

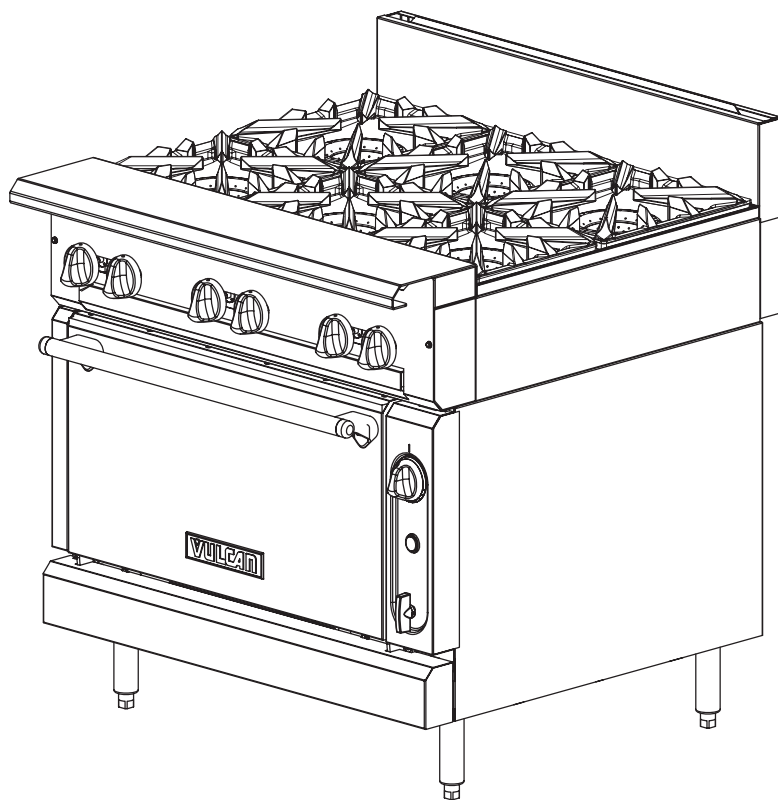

V6B36S Shown

For additional information on Vulcan- Hart or to locate an authorized parts and service provider in your area, visit our website at [www.VulcanHart.com](http://www.VulcanHart.com).

36" WIDE RANGES

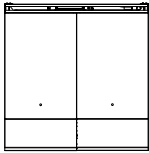

V236H  
V236HS  
V236HC  
V236HB

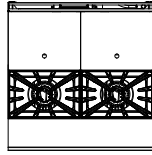

no model?

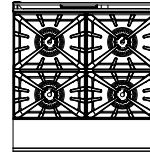
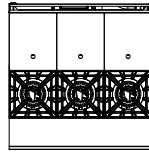
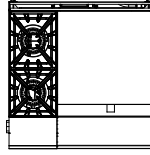
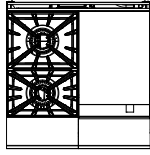
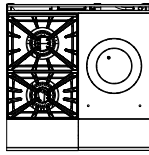

---

**TABLE OF CONTENTS**

B MODEL 36" CABINET BASE .....	4
S MODEL OVEN .....	6
S MODEL GAS MANIFOLD ASSY .....	8
C MODEL OVEN .....	10
C MODEL GAS MANIFOLD ASSY .....	12
36" 6 OPEN TOP BURNER .....	14
36" 4 OPEN TOP BURNER .....	16
36" CHAR BROILER .....	18
36" FRENCH TOP .....	20
36" GRIDDLE TOP .....	22
36" WORK TOP .....	24
36" & 18" OPEN TOP BURNER STEP UP .....	26
36" 6 OPEN TOP BURNER STEP UP .....	28

"B" MODEL 36" CABINET BASE

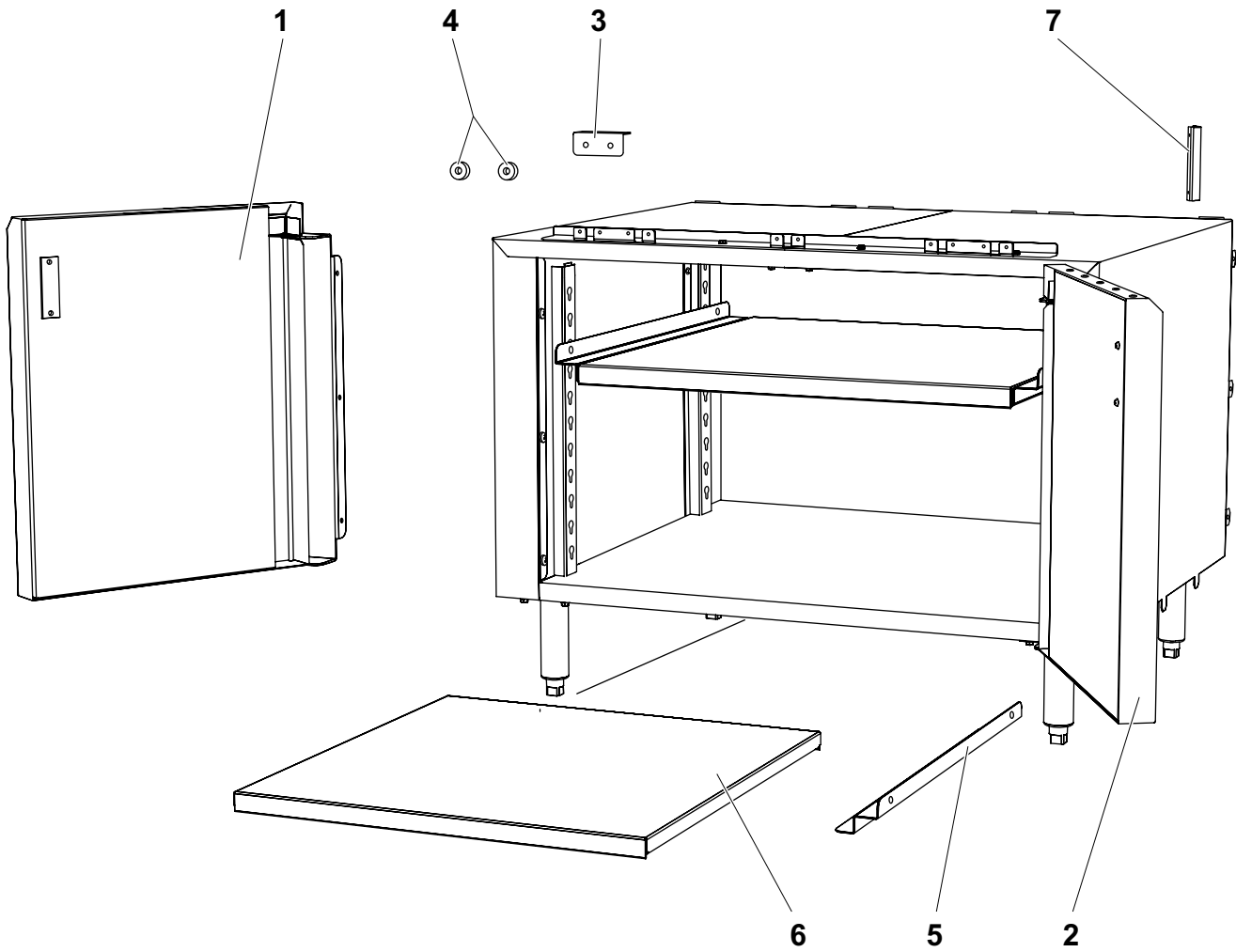

Figure 1

**“B” MODEL 36” CABINET BASE**

ILLUS.	PART NO.	DESCRIPTION	QTY.
Fig. 1			
* 1	958087-G4	DOOR ASSY L/H .....	1
2	958087-G5	DOOR ASSY R/H .....	1
3	499740-1	BRACKET, CABINET DOOR MAGNET .....	1
4	497296-1	MAGNET, DOOR .....	2
5	499744-G1	SHELF SUPPORT .....	2
* 6	499747-1	SHELF .....	1
7	408615-21	HANDLE, DOOR, KEELER R3122 .....	2

**\* “B” MODEL 24” CABINET BASE**

1	958087-G3	DOOR ASSY.....	1
6	499747-2	SHELF.....	1

**\* “B” MODEL 18” CABINET BASE**

1	958087-G2	DOOR ASSY.....	1
6	499747-3	SHELF.....	1

**\* “B” MODEL 12” CABINET BASE**

1	958087-G1	DOOR ASSY.....	1
---	-----------	----------------	---

\* ALL PARTS THE SAME AS ON THE 36” EXCEPT AS NOTED.

"S" MODEL OVEN

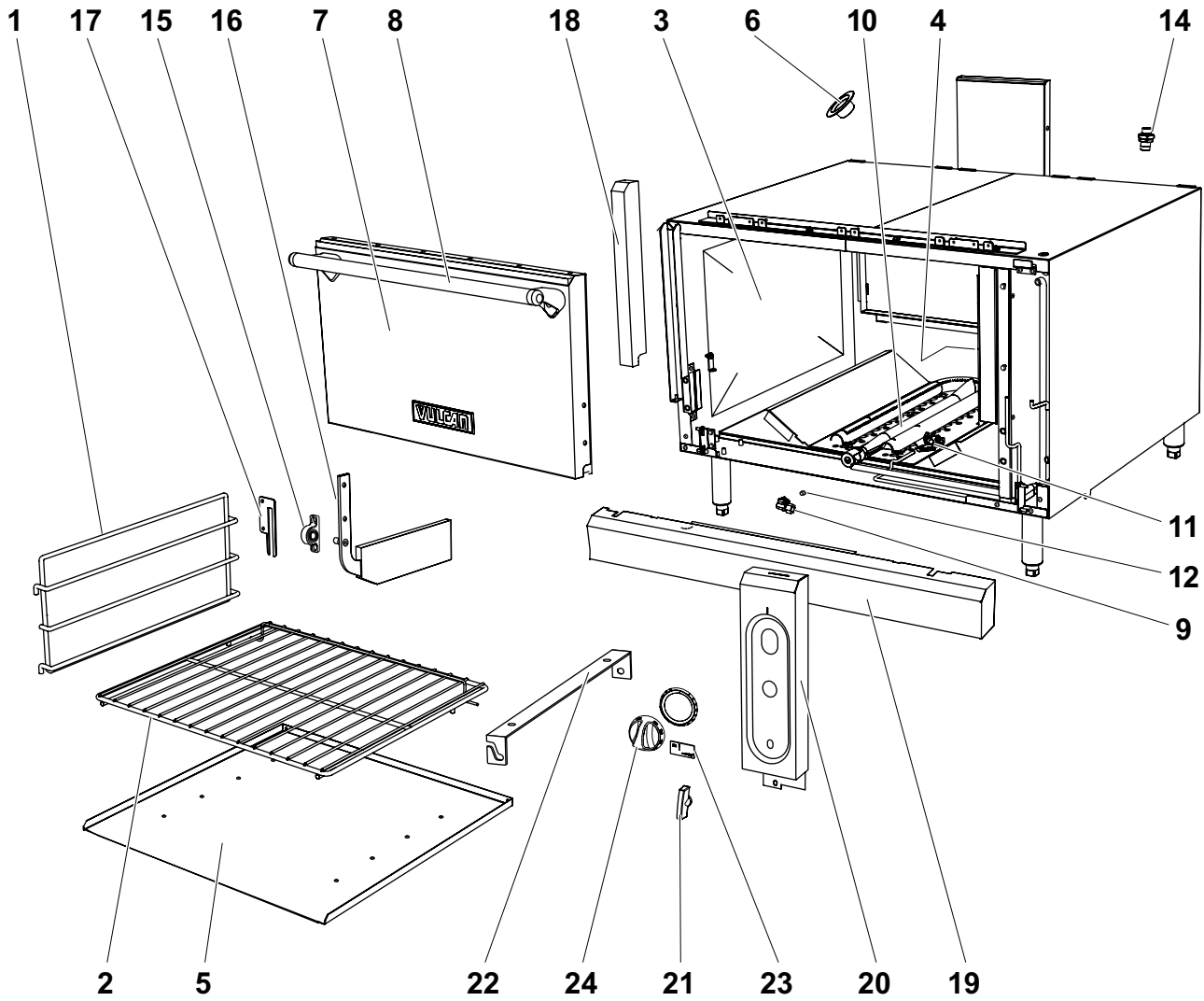

Figure 2

## "S" MODEL OVEN

ILLUS.	PART NO.	DESCRIPTION	QTY.
Fig.2			
1	499468-1	SUPPORT,WIRERACK .....	2
2	499517-2	OVEN,RACK .....	1
3	499467-1	OVENLINERR/H - POR .....	1
3A	499467-3	OVEN LINER R/H - SST .....	1
4	499467-2	OVENLINERL/H - POR .....	1
4A	499467-4	OVEN LINER L/H - SST .....	1
5	499800-G1	BOTTOM LINER - POR .....	1
5A	499467-4	BOTTOM LINER - SST .....	1
NS	405915-3	BRKT, GRAVITY PANEL .....	1
6	405930-1	EYELET BRASS .....	1
7	499513-G1	DOOR ASSY - POR .....	1
7A	499513-G2	DOOR ASSY - SST .....	1
8	956635-1	HANDLE,OVEN DOOR .....	1
9	404079-F	NOZZLE,90 DEG BURNER .....	1
10	497891-1	BURNER,OVEN .....	1
11	412787-1	PILOT - NATURAL GAS .....	1
	412787-2	PILOT - LP GAS .....	1
12		ORIFICE - NATURAL GAS .....	1
		ORIFICE - LP GAS .....	1
14	499554-1	DISCONNECT,MAIN QMALE .....	1
15	497906-1	BLOCK,PILLOW .....	2
16	499512-G3	OVENCOUNTERWEIGHTR/H .....	1
	499512-G4	OVENCOUNTERWEIGHTL/H .....	1
17	499452-1	COVERPLATE .....	2
18	958353-1	COVER,MOULIAN,PANEL .....	1
19	958470-G1	KICKPANEL .....	1
20	499507-1	OVEN CONTROL PANEL .....	1
21	413157-1	KNOB,SHUT OFF .....	1
22	497883-1	THERMOSTAT BULB BRKT .....	1
23	414708-1	ON/OFF PLATE .....	1
24	499168-1	OVEN KNOB 650°F .....	1
	499168-2	OVEN KNOB 550°F .....	1

NS = Not Shown

“S” MODEL GAS MANIFOLD ASSY

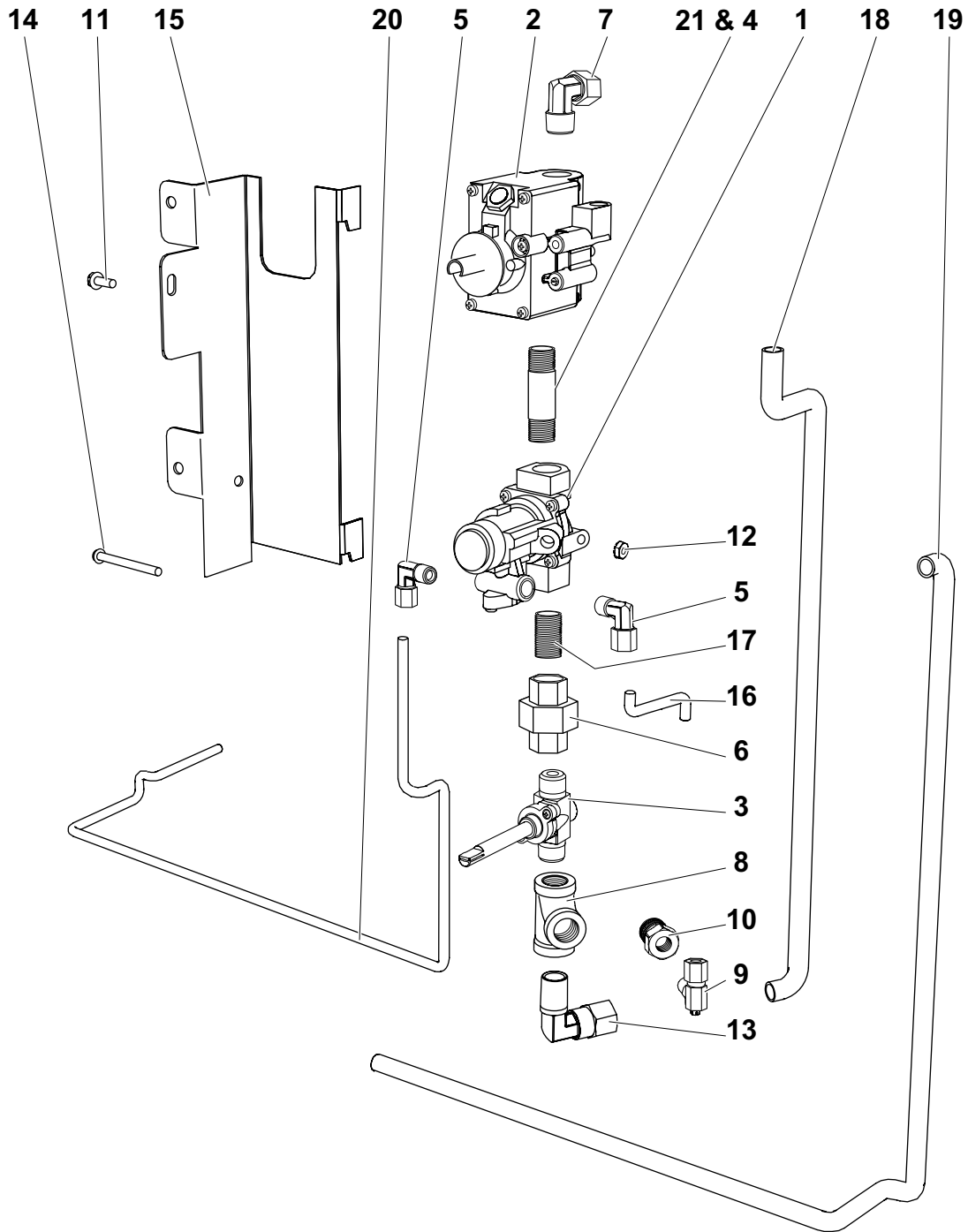

Figure 3

---

**“S” MODEL GAS MANIFOLD ASSY**

ILLUS.	PART NO.	DESCRIPTION	QTY.
Fig. 3			
1	497765-1	PILOT SAFETY VALVE .....	1
2	407522-7	THERMOSTAT, 550°F .....	1
	407522-8	THERMOSTAT, 400-650°F .....	1
3	719971	MANUAL GAS SHUT-OFF VALVE .....	1
4	FP-035-56	PIPE, 3/8 X 2.500 .....	1
5	FP-012-21	FITTING, ELBOW, 1/4TX 1/8NPT .....	2
6	719032	3/8NPTUNION .....	1
7	FP-085-68	FITTING, ELBOW 7/16TX 3/8MPT .....	1
8	719037	PIPE, TEE 3/8 X 3/8 X 3/8 .....	1
9	404193-1	PILOT ADJUSTVLV, 260BROILER .....	1
10	719066	BUSHING PIPE 3/8 - 1/8 .....	1
11	SD-032-07	#10-24 X 0.5 X 0.5-N .....	1
12	NS-044-09	#10-24 LOCKNUT .....	1
13	FP-012-03	FITTING, ELBOW, 1/2TX 3/8NPT .....	1
14	SC-060-38	SCREW, MACHINE, 10-24 X 2.000 .....	1
15	499465-1	GASMOUNTINGBRKT .....	1
16	426505-9	TUBE 1/4 X 9" FLEX .....	1
17	FP-035-46	PIPE, 3/8 X 1.000 .....	1
18	426509-24	TUBE, FLEX 1/2 O.D. - 24" .....	1
19	426508-48	TUBE, FLEX 7/16 O.D. - 48" .....	1
20	426505-36	TUBE, FLEX 1/4 O.D. - 36" .....	1
21	412788-4	"T" COUPLE - 48" .....	1

“C” MODEL OVEN

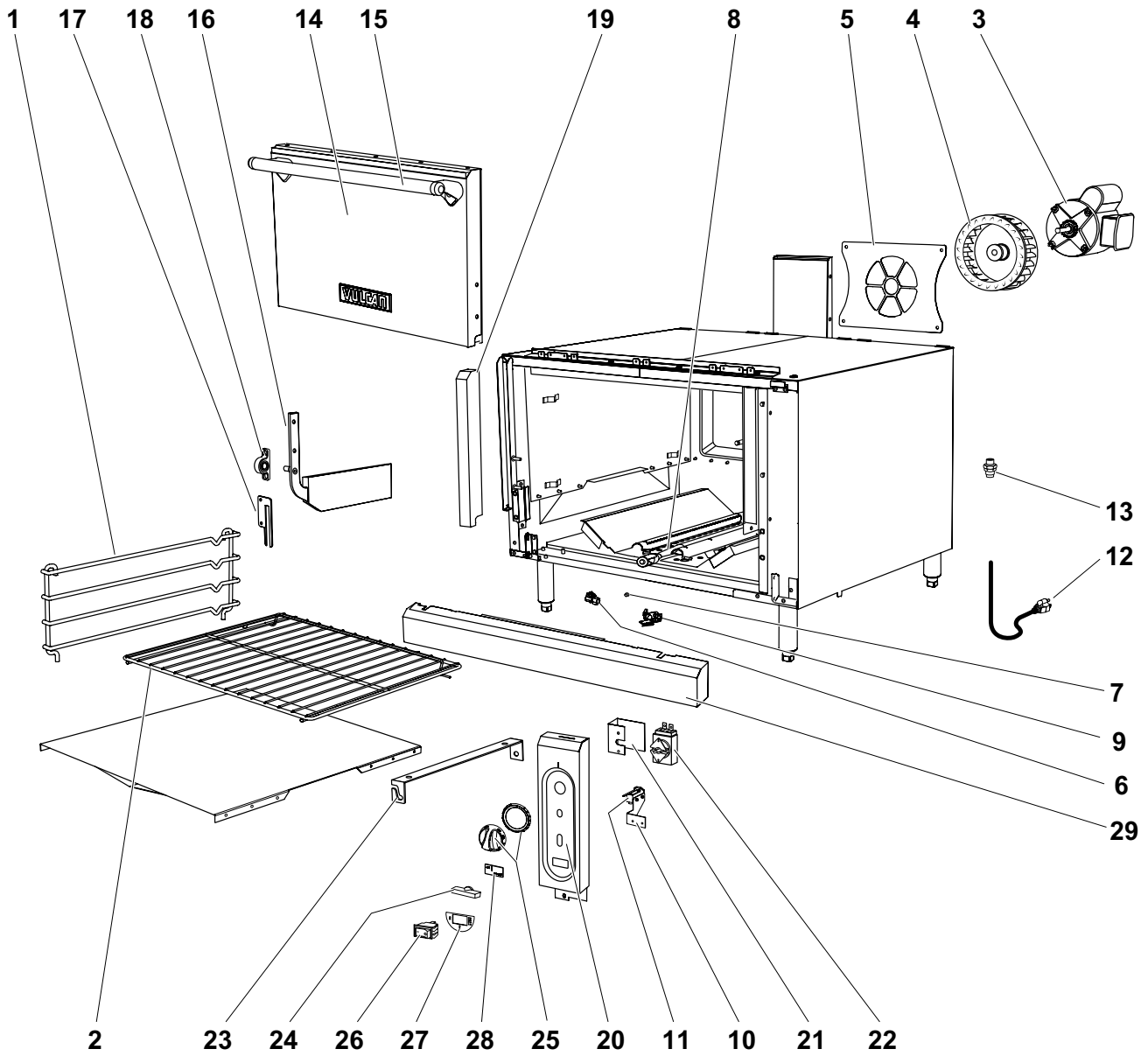

Figure 4

## "C" MODEL OVEN

ILLUS.	PART NO.	DESCRIPTION	QTY.	
Fig. 4	1	499468-2	SUPPORT, WIRERACK .....	1
		499468-3	SUPPORT, WIRERACK .....	1
	2	499517-2	OVEN, RACK .....	2
	3	499547-G1	MOTOR, 1/6 HP, 120V .....	1
	4	415780-8	ROTOR, AI .....	1
	5	499641-1	GRATE, MOTOR, CONVOVEN .....	1
	6	404079-F	NOZZLE, 90 DEG BURNER .....	1
	7		ORIFICE - NATURAL GAS .....	1
			ORIFICE - LPGAS .....	1
	8	497891-1	BURNER, OVEN .....	1
	9	412787-1	PILOT - NATURAL GAS .....	1
		412787-2	PILOT - LP GAS .....	1
	10	956633-2	SWITCH BRKT .....	1
	11	411496-F1	SWITCH, MICRO .....	1
	12	405016-1	CORD, SUPPLY ELECTRIC .....	1
	13	499554-1	DISCONNECT, MAIN Q MALE .....	1
	14	499513-G1	DOOR ASSY - POR .....	1
14A		499513-G2	DOOR ASSY - SST .....	1
	15	956635-1	HANDLE, OVEN DOOR .....	1
	16	499512-G6	COUNTERWEIGHT ASSY R/H .....	1
		499512-G3	COUNTERWEIGHT ASSY L/H .....	1
	17	499452-1	COVERPLATE .....	2
	18	497906-1	BLOCK, PILLOW .....	2
	19	958353-1	COVER, MOULIAN, PANEL .....	1
	20	499507-3	CONTROL PANEL COVER .....	1
	21	957464-1	THERMOSTAT GUARD .....	1
	22	411506-14	THERMOSTAT, 200 - 550F .....	1
	23	497883-2	THERMOSTAT BULB BRKT .....	1
	24	413157-1	KNOB, SHUT OFF .....	1
	25	499168-3	OVEN, KNOB - 550F - CONVECTION .....	1
	26	715112	SWITCH, LIGHTED ROCKER .....	1
	27	957609-1	LABEL, ON-OFF COOL DOWN .....	1
	28	414708-1	PLATE, ON-OFF .....	1
	29	499515-G1	KICK PANEL ASSY .....	1
NS		497694-1	WIREDIAGRAM .....	1
NS		497698-1	DECAL, WIRE SCHEMATIC .....	1

NS = Not Shown

“C” MODEL GAS MANIFOLD ASSY

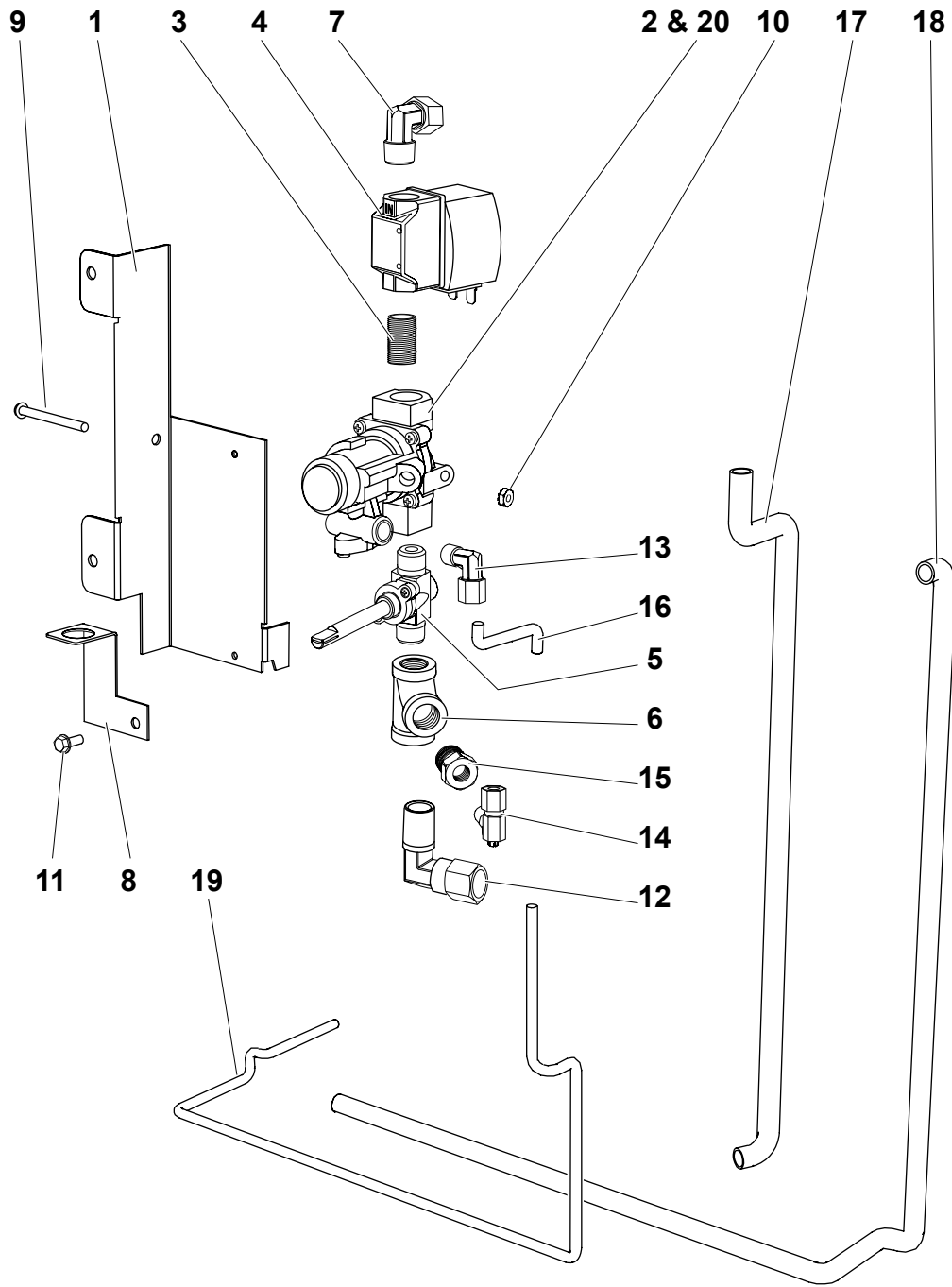

Figure 5

---

**“C” MODEL GAS MANIFOLD ASSY**

ILLUS.	PART NO.	DESCRIPTION	QTY.
Fig. 5			
1	499651-3	GAS MOUNTING BRKT (CONV) .....	1
2	497765-1	VALVE, PILOT SAFETY – BASSO .....	1
3	FP035-47	PIPE 3/8 X 1.125 .....	1
4	428045-1	VALVE, SOLENOID .....	1
5	719971	VALVE, MANUAL GAS SHUT-OFF .....	1
6	719037	TEE, PIPE 3/8 X 3/8 X 3/8 .....	1
7	FP-085-68	FITTING, TUBE 7/16 .....	1
8	956615-2	BRACKET, MANIFOLD SUPPORT .....	1
9	SC-060-38	SCREW, MACH, 10-24 X 2.000 .....	1
10	NS-044-09	#10-24 LOCKNUT .....	1
11	SD-032-07	#10-24 X 0.5 X 0.5-N .....	1
12	FP-012-03	FITTING, TUBE 1/2 .....	1
13	FP-012-21	FITTING, TUBE 1/4 .....	1
14	404193-1	VALVE, 1/8 NPT X 1/4 CC X 90 DEG .....	1
15	FP026-04	BUSHING, PIPE 3/8 – 1/8 .....	1
16	426505-6	TUBE, FLEX 1/4 O.D. - 6" .....	1
17	426509-24	TUBE, FLEX 1/2 O.D. - 24" .....	1
18	426508-48	TUBE, FLEX 7/16 O.D. - 48" .....	1
19	426505-36	TUBE, FLEX 1/4 O.D. - 36" .....	1
20	412788-4	“T” COUPLE - 48" .....	1

36" OPEN TOP BURNER

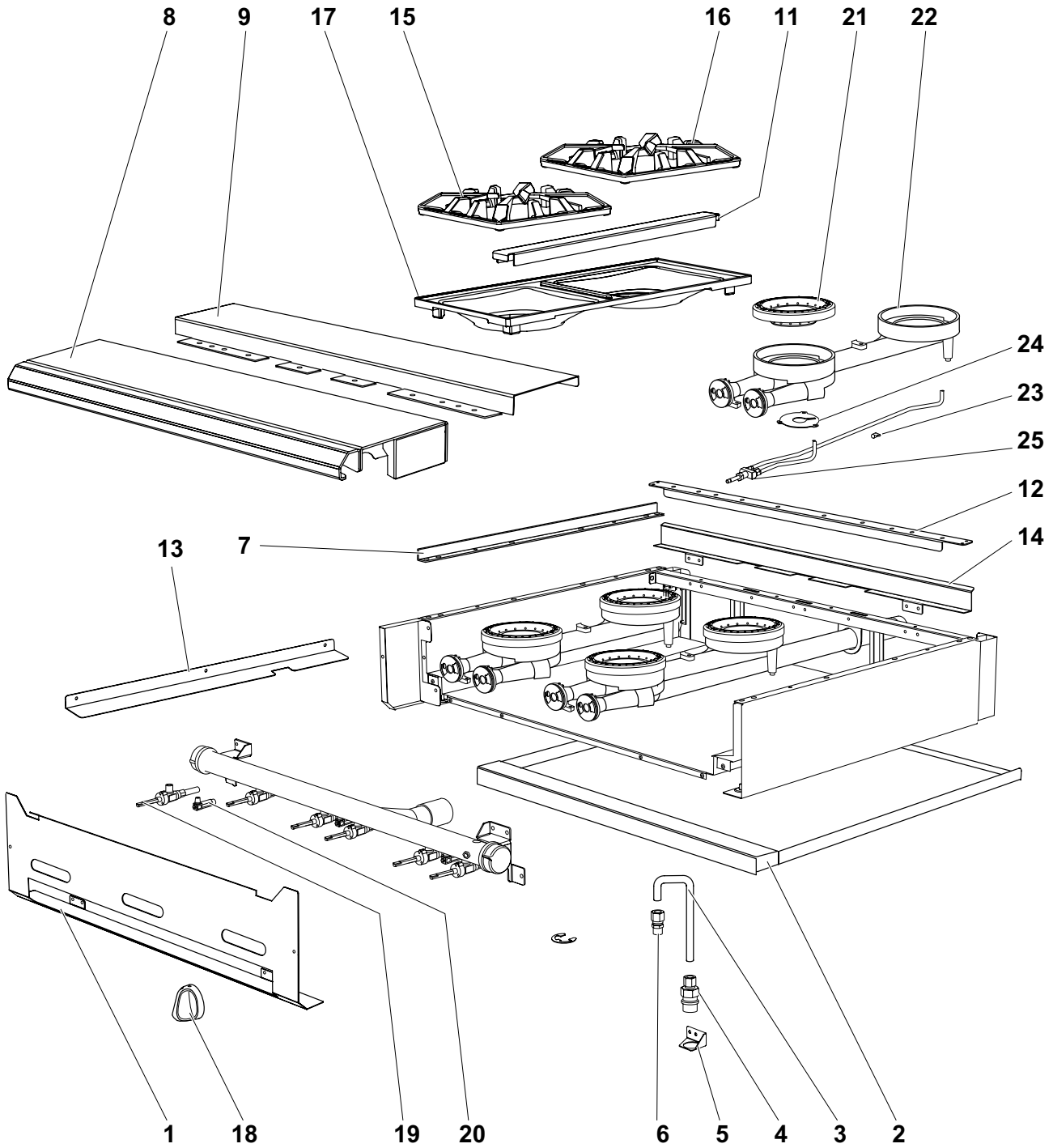

Figure 6

**36" 6 OPEN TOP BURNER**

ILLUS.	PART NO.	DESCRIPTION	QTY.
Fig. 6			
* 1	957575-1	MANIFOLD COVER .....	1
* 2	499006-G2	CRUMB TRAY - SST .....	1
3	956509-10	TUBE, FLEX 10" .....	1
4	499555-1	GAS DISCONNECT FEMALE .....	1
5	499047-1	DISCONNECT BRKT .....	1
6	FP-012-02	FITTING, TUBE 1/2" .....	1
7	497984-1	GRATE, RETAINER .....	2
* 8	499425-G1	FRONT TOP ASSY .....	1
* 9	957235-G1	FRONT TOP ASSY - CONDIMENT RAIL .....	1
	957239-G1	FRONT TOP SLIDE RAIL ASSY .....	1
*NS	957067-G1	RISER STUBBY .....	1
11	499493-1	SUPPORT, GRATE - ALUM .....	2
	499493-2	SUPPORT, GRATE - SST .....	2
*12	499001-2	SUPPORT, HD BURNER, SST .....	1
13	499002-3	DEFLECTOR, HD SPLASH, SST L/H .....	1
	499002-4	DEFLECTOR, HD SPLASH, SST R/H .....	1
*14	499615-2	DEFLECTOR, REAR, SST .....	1
15	957368-1	GRATE, FRONT, 12" .....	3
16	957369-1	GRATE, REAR, 12" .....	3
17	957341-1	BOWL, REAR 12" DOUBLE .....	3
18	499712-1	KNOB, HD BURNER .....	6
19	957367-1	VALVE, BURNER .....	6
20	499970-1	VALVE, PILOT QUICK DISCNT HD .....	3
21	957343-2	BURNER, HEAD 6" .....	6
22	957342-1	VENTURI ASSY .....	6
23	402558-4	TUBE CLIP .....	12
24	958073-2	PLATE, RESTRICTOR .....	6
25	499971-1	PILOT, QUICK DISC. ASSY, HD .....	3

NS = Not Shown

**\*24" 4 OPEN TOP BURNER**

1	957570-1	MANIFOLD COVER .....	1
2	956724-G2	CRUMB TRAY - SST .....	1
8	956705-G1	FRONT TOP ASSY .....	1
9	957357-G1	FRONT TOP ASSY - CONDIMENT RAIL .....	1
NS	957066-G1	RISER STUBBY .....	1
12	956718-2	SUPPORT, HD BURNER, SST .....	1
14	956725-2	DEFLECTOR, REAR, SST .....	1

NS = Not Shown

**\*12" 2 OPEN TOP BURNER**

1	957559-1	MANIFOLD COVER .....	1
2	499969-G2	CRUMB TRAY - SST .....	1
8	499966-G1	FRONT TOP ASSY .....	1
NS	957066-G1	RISER STUBBY .....	1
12	499965-2	SUPPORT, HD BURNER, SST .....	1
14	499935-1	DEFLECTOR, REAR, SST .....	1

NS = Not Shown

\*ALL PARTS THE SAME AS ON THE 36" EXCEPT AS NOTED.

\*\* FOR STEP-UP BURNER BREAKDOWN, SEE PAGE 26.

36" 4 OPEN TOP BURNER

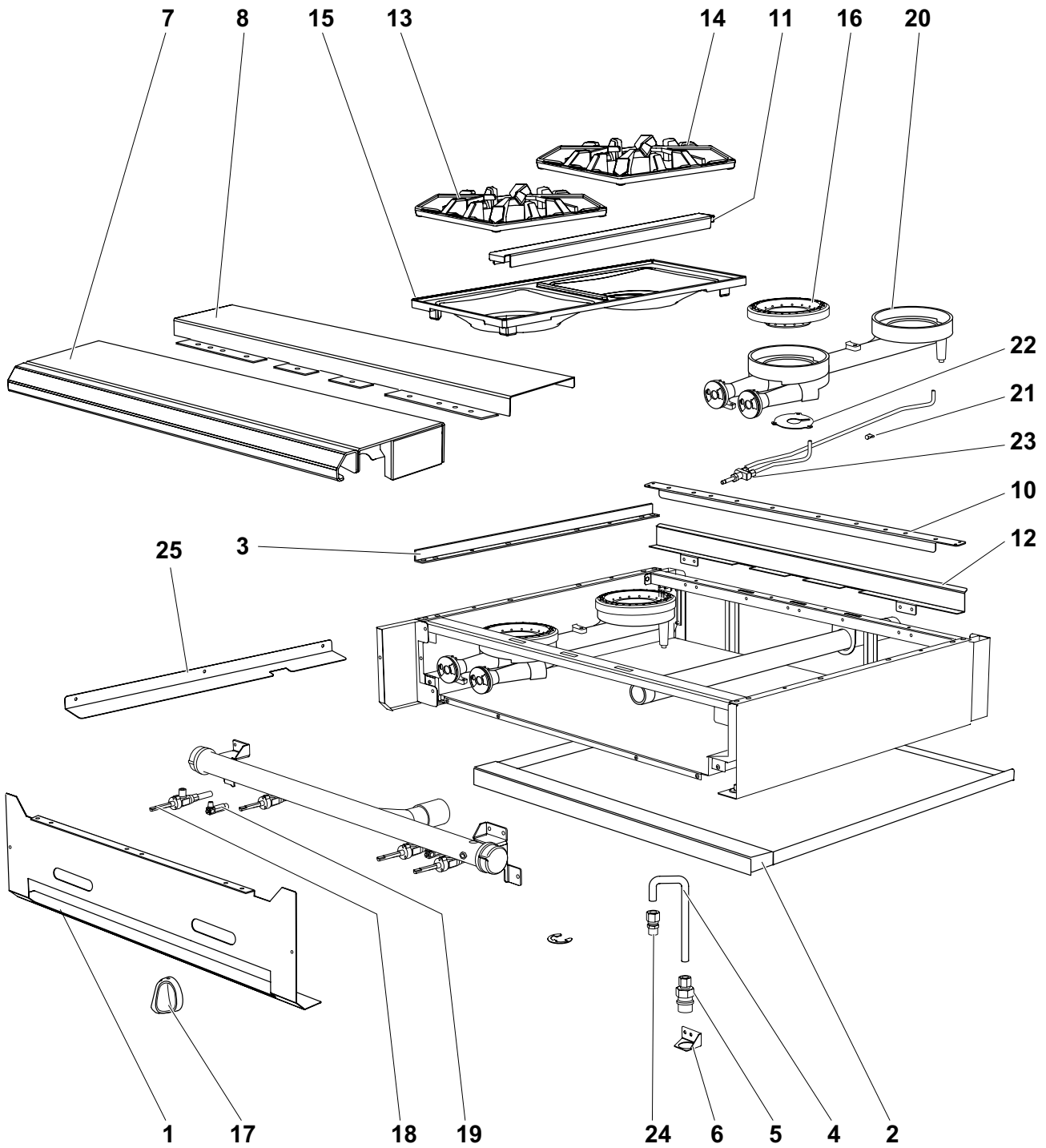

Figure 7

**36" 4 OPEN TOP BURNER**

ILLUS.	PART NO.	DESCRIPTION	QTY.
Fig. 7			
* 1	957573-1	MANIFOLD COVER .....	1
* 2	499006-G2	CRUMB TRAY - SST .....	1
3	497984-1	GRATE, RETAINER .....	2
4	426509-10	TUBE, FLEX 10" .....	1
5	499555-1	GAS DISCONNECT FEMALE .....	1
6	499047-1	DISCONNECT BRKT .....	1
* 7	499425-G1	FRONT TOP ASSY .....	1
	957235-G1	FRONT TOP ASSY - CONDIMENT RAIL .....	1
8	957239-G1	FRONT TOP SLIDE RAIL ASSY .....	1
* NS	957067-G1	RISER STUBBY .....	1
* 10	499001-4	SUPPORT, SST - (4) OTB BURNER .....	1
11	499493-1	SUPPORT, GRATE - ALUM .....	1
	499493-2	SUPPORT, GRATE - SST .....	1
* 12	499615-2	DEFLECTOR, REAR - SST .....	1
13	957370-1	GRATE, FRONT 18" .....	2
14	957371-1	GRATE, REAR 18" .....	2
15	957372-1	BOWL, 18" DOUBLE .....	2
16	957343-2	BURNER, HEAD 6" .....	4
17	499712-1	KNOB, HD BURNER .....	4
18	957367-1	VALVE, BURNER .....	4
19	499970-1	VALVE, PILOT QUICK DISCNT HD .....	2
20	957398-G1	VENTURI ASSY .....	1
21	402558-4	TUBECLIP .....	6
22	958073-1	PLATE, RESTRICTOR .....	4
23	499971-1	PILOT, QUICK DISC. ASSY, HD .....	2
24	FP012-02	FITTING, TUBE 1/2" .....	1
25	499002-3	DEFLECTOR, HD SPLASH, SST L/H .....	1
	499002-4	DEFLECTOR, HD SPLASH, SST R/H .....	1

NS = Not Shown

**\*18" 2 OPEN BURNER**

1	957564-1	MANIFOLD COVER .....	1
2	956696-G2	CRUMB TRAY - SST .....	1
7	956658-G1	FRONT TOP ASSY .....	1
NS	957065-G1	RISER STUBBY .....	1
10	956690-1	SUPPORT, SST - (2) OTB BURNER .....	1
12	956697-2	DEFLECTOR REAR, SST .....	1

\* ALL PARTS THE SAME AS ON THE 36" EXCEPT AS NOTED.

\*\* FOR STEP-UP BURNER BREAKDOWN, SEE PAGE 28.

36" CHAR BROILER

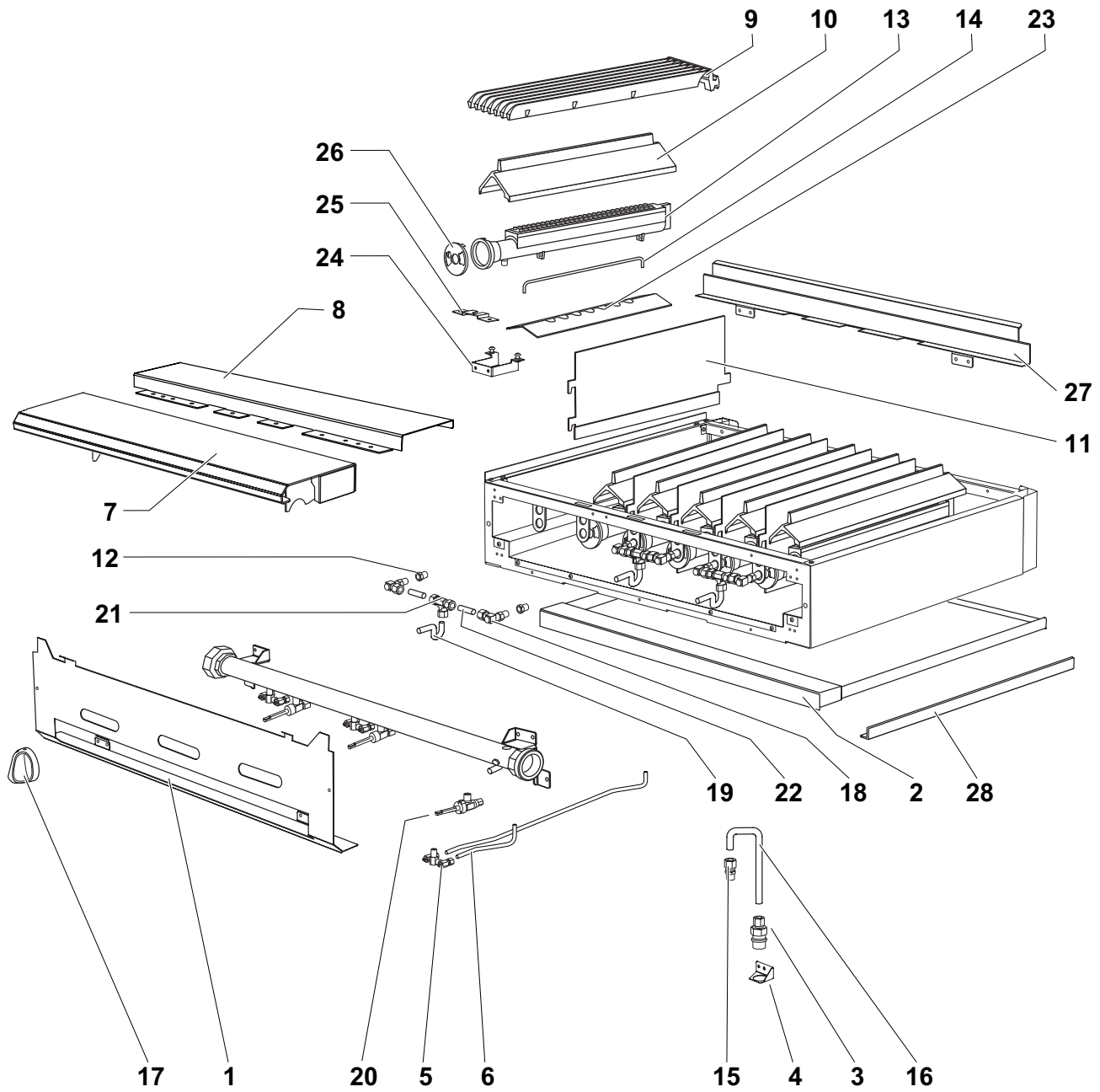

Figure 8

**36" CHAR BROILER**

ILLUS.	PART NO.	DESCRIPTION	QTY.
Fig. 8			
*1	957574-1	MANIFOLD COVER .....	1
*2	499006-G2	CRUMB TRAY - SST .....	1
3	499555-1	GAS DISCONNECT FEMALE .....	1
4	499047-1	DISCONNECT BRKT .....	1
5	957814-1	DUAL PILOT VALVE – 3/16 .....	1
6	788541A	PILOT TUBE .....	4
*7	499425-G1	FRONT TOP ASSY .....	1
*8	957235-G1	FRONT TOP ASSY – CONDIMENT RAIL .....	1
	957239-G1	FRONT TOP SLIDE RAIL ASSY .....	1
*NS	957067-G1	RISER STUBY .....	1
9	412852-1	TOP GRATE .....	6
10	710407	RADIANT .....	6
11	956614-2	SUPERCHARGER .....	5
12	418051-F	VALVE HOOD .....	6
13	957413-1	BURNER ASSY .....	6
14	710455	BURNER ROD .....	4
15	FP012-02	FITTING, TUBE 1/2" .....	1
16	426509-10	TUBE, FLEX ½ O.D. ....	1
17	499712-1	KNOB, HD BURNER .....	3
18	719383	BRASS ANGLE FITTING .....	6
19	722425	3/8 FLEX TUBE 8" LONG .....	3
20	957348-1	GAS VALVE .....	3
21	714676	3/8 COMPRESSION TEE .....	3
22	722468	3/8 TUBE 1-1/4" LONG .....	1
23	956748-1	HEAT DEFLECTOR .....	6
24	957412-1	DUAL PILOT BRACKET .....	6
25	957335-1	BURNER STABILIZER .....	6
26	719329	AIR MIXER ASSY .....	6
*27	499615-2	DEFLECTOR, REAR – SST .....	1
28	497984-1	GRATE, RETAINER .....	2

NS = Not Shown

**\*24" CHAR BROILER**

1	957567-1	MANIFOLD COVER .....	1
2	956724-G2	CRUMB TRAY - SST .....	1
7	956705-G1	FRONT TOP ASSY .....	1
8	957357-G1	FRONT TOP ASSY - CONDIMENT RAIL .....	1
NS	957066-G1	RISER STUBY .....	1
27	956725-2	DEFLECTOR REAR, SST .....	1
NS	722131	GRATE .....	2

\* ALL PARTS THE SAME AS ON THE 36" EXCEPT AS NOTED.

36" FRENCH TOP

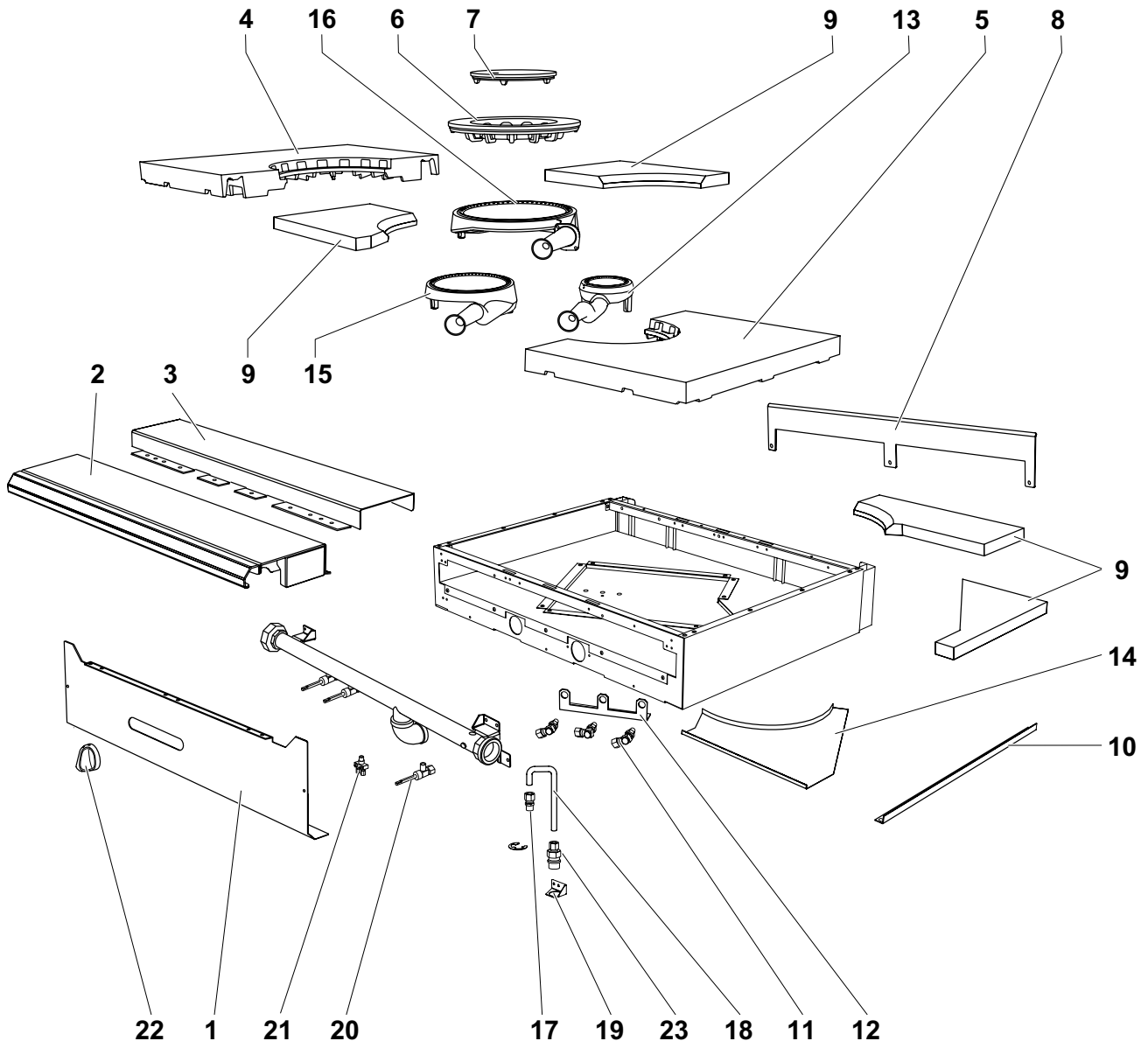

Figure 9

### 36" RADIAL FIN HOT TOP

ILLUS.	PART NO.	DESCRIPTION	QTY.
Fig. 9			
*1	957576-1	COVER, MAN, 36" FRN TP W/RAIL .....	1
*2	499425-G1	FRONT TOP ASSY .....	1
3	957235-G1	FRONT TOP ASSY CONDEMENT RAIL .....	1
	957239-G1	FRONT TOP SLIDE RAIL ASSY .....	1
*NS	957067-G1	RISERSTUBY .....	1
*4	499814-1	CASTING, LH- RADIAL FIN. - 36".....	1
5	499814-2	CASTING, RH- RADIAL FIN. - 36".....	1
6	400705-1	RING, TOP .....	1
7	715211-GR	PLATE TOP .....	1
*8	956809-2	DEFLECTOR, RADIAL FIN REAR .....	1
*9	956622-G1	BRICKSET .....	1
10	497984-1	GRATE, RETAINER .....	1
NS	409807-1	PILOT BRACKET .....	1
NS	409839-1	PILOT - NATUARAL GAS .....	2
NS	409839-3	PILOT - PROPANE .....	2
11	719383	ELBOW, 3/8" ORIFICE W/O PLUG .....	1
12	499810-2	PILOT BRACKET .....	1
*13	957801-G1	BURNER, INNER - RADIAL FIN .....	1
*14	957946-G1	PLATE, AERATION, ASSY .....	1
*15	409413-1	BURNER, CASTING .....	1
16	409412-1	BURNER, CASTING .....	1
17	FP012-02	FITTING, TUBE 1/2" .....	1
18	426509-10	TUBE, FLEX 1/2 O.D. - 10" .....	1
19	499047-1	BRACKET, DISCONNECT .....	1
20	408379-3	BURNER VALVE .....	3
21	957814-1	DUAL PILOT VALVE - 3/16 .....	1
22	499712-1	KNOB, HD BURNER .....	3
23	499555-1	DISCONNECT, MAIN Q FEMALE .....	1
NS	426509-18	TUBE, FLEX 1/2 O.D. - 18" .....	3
NS	426505-14	TUBING, FLEX 1/4 .....	2

NS - Not Shown

### \*18" RADIAL FIN HOT TOP

1	957563-1	MANIFOLD COVER .....	1
2	956658-G1	FRONT TOP ASSY .....	1
NS	957065-G1	RISER STUBY .....	1
4	956800-1	RADIAL FIN CASTING .....	1
8	956663-1	DEFLECTOR, RADIAL FIN .....	1
9	956799-G1	BRICK SET .....	1
13	956794-1	BURNER, 18" INNER .....	1
14	957710-G1	PLATE, AERATION ASSY .....	1
15	956793-1	BURNER, 18" OUTER .....	1

\* ALL PARTS THE SAME AS ON THE 36" EXCEPT AS NOTED.

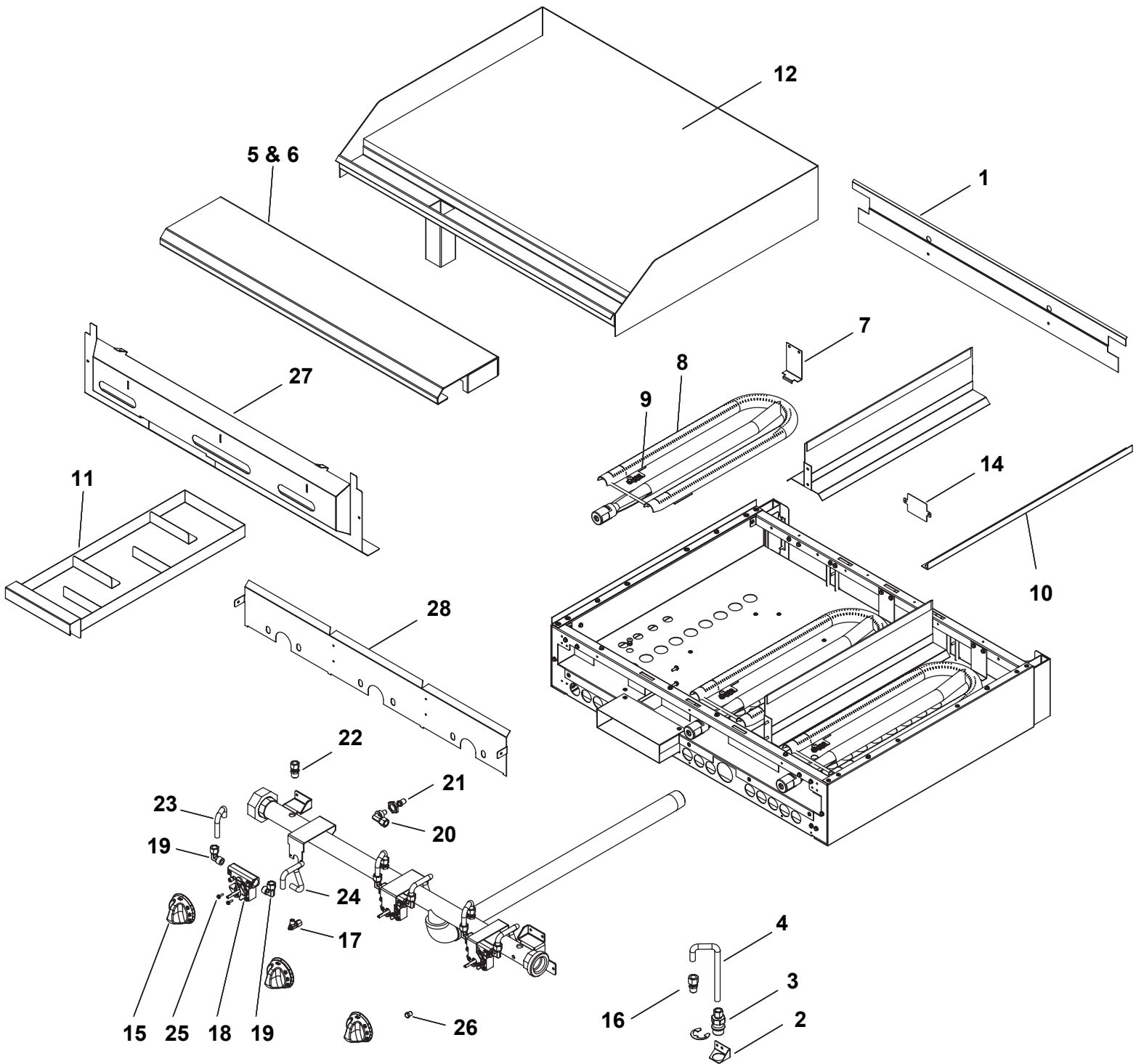

Figure 10

**36" THERMO CONTROL GRIDDLE TOP**

ILLUS.	PART NO.	DESCRIPTION	QTY.
Fig. 10			
1	957961-1	HD 36" REAR CLOSEOUT PANEL .....	1
2	499047-1	HD DISCONNECT BRACKET.....	1
3	499555-1	HD GAS DISCONNECT, FEMALE .....	1
4	426509-10	FLEX TUBING, 1/2" x 16.0" LG .....	1
5	499425-G1	FRONT TOP ASSY.....	1
6	957235-G1	FRONT TOP ASSY - CONDIMENT RAIL .....	1
	957239-G1	FRONT TOP SLIDE RAIL ASSY .....	1
7	499112-1	HD GRIDDLE BURNER SUPPORT BRACKET .....	3
8	499635-1	HD GRIDDLE BURNER ASSY.....	3
9	413302-1	PILOT TIP CLIP.....	3
10	497984-1	HD GRATE RETAINER .....	2
11	957982-G4	HD GRIDDLE GREASE DRAWER ASSY.....	1
12	499622-G2	HD GRIDDLE ASSY - 36".....	1
13	957170-G1	HD GRIDDLE BAFFLE ASSY, CENTER (NOT SHOWN) .....	2
14	956662-1	HD HOT TOP / GRIDDLE REAR MANIFOLD COVER .....	1
15	958063-G1	HD T-STAT GRIDDLE KNOB ASSY .....	3
16	FP012-02	FITTING TUBE 1/2" x 3/8" PIPE .....	1
17	404193-1	PILOT ADJUST VALVE, 260 BROILER.....	3
18	499488-1	GAS THERMOSTAT.....	3
19	FP085-68	FITTING, ELBOW 7/16" x 3/8" MPT.....	6
20	404079-F	NOZZLE .....	3
21	418051-F	VALVE HOOD.....	3
22	FP085-42	FITTING TUBE 7/16" x 3/8" PIPE.....	3
23	426508-6	7/16" FLEX TUBE, 6" LG.....	3
24	426508-10	7/16" FLEX TUBE, 10" LG.....	3
25	SD036-79	# 6-36 HEX HEAD SCREW.....	6
26	FP085-53	PIPE PLUG 1/8 NPT.....	1
27	957604-G2	HD 36" T-STAT MANIFOLD COVER ASSY COND RAIL.....	1
28	957396-2	GRIDDLE BAFFLE.....	1
29	788541-A	PILOT TUBE WITH TIP .188 (NOT SHOWN) .....	2
30	956939-2	PILOT TUBE WITH TIP .188 (NOT SHOWN) .....	1

**\*24" THERMO CONTROL GRIDDLE TOP**

1	957989-1	HD 24" REAR CLOSEOUT PANEL.....	1
5	956705-G1	24" FRONT TOP ASSY.....	1
6	957357-G1	24" FRONT TOP ASSY CONDIMENT RAIL .....	1
11	956709-G4	HD 24" GRIDDLE GREASE DRAWER ASSY .....	1
12	499957-G2	HD GRIDDLE ASSY 24" - T/G .....	1
14	956710-1	HD 24" GRIDDLE / HOT TOP COVER PLATE .....	1
27	957602-G2	HD 24" T-STAT MANIFOLD COVER ASSY COND RAIL .....	1
28	957988-2	HD 24" FORWARD GRIDDLE BAFFLE .....	1

**\*18" THERMO CONTROL GRIDDLE TOP**

1	957993-1	HD 18" REAR CLOSEOUT PANEL .....	1
5	956658-G1	HD FRONT TOP ASSY 18" .....	1
6	957235-G1	18" FRONT TOP ASSY CONDIMENT RAIL .....	1
11	956677-G4	HD 18" GRIDDLE GREASE DRAWER ASSY .....	1
12	956674-G2	HD 18" GRIDDLE ASSY .....	1
27	957594-G1	HD 18" T-STAT MANIFOLD COVER ASSY .....	1
28	957992-2	HD 18" FORWAED GRIDDLE BAFFLE .....	1

\* ALL PARTS THE SAME AS ON THE 36" EXCEPT AS NOTED.

36" WORK TOP

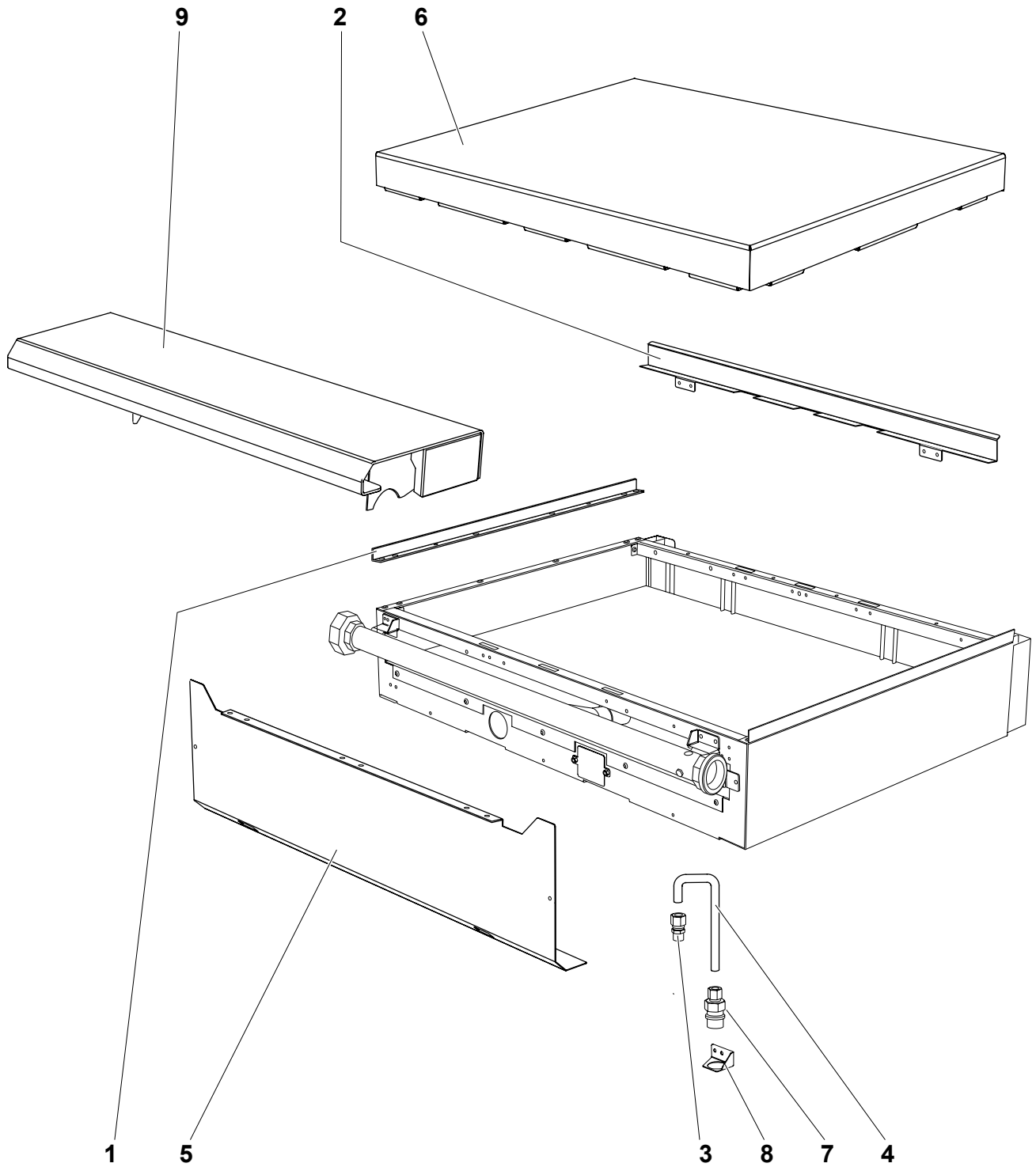

Figure 11

**36" WORK TOP**

ILLUS.	PART NO.	DESCRIPTION	QTY.
Fig. 11			
1	497984-1	GRATE, RETAINER .....	2
*2	499615-2	DEFLECTOR, REAR-SST .....	1
3	FP012-02	FITTING, TUBE 1/2" .....	1
4	426509-10	TUBE, FLEX 1/2 O.D. - 24" .....	1
*5	957580-1	MANIFOLD COVER .....	1
*6	956639-G1	WORKTOP .....	1
7	499555-1	GAS DISCONNECT FEMALE .....	1
8	499047-1	DISCONNECT BRKT .....	1
*9	499425-G1	FRONT TOP ASSY .....	1
	957235-G1	FRONT TOP ASSY CONDEMENT RAIL .....	1
*NS	957067-G1	RISER STUBY .....	1

NS = Not Shown

**\*24" WORK TOP**

2	956725-2	DEFLECTOR, REAR SST.....	1
5	957572-1	MANIFOLD COVER .....	1
6	956639-G2	WORK TOP .....	1
9	956705-G1	FRONT TOP ASSY .....	1
	957357-G1	FRONT TOP ASSY - CONDIMENT RAIL .....	1
NS	957066-G1	RISER STUBY .....	1

**\*18" WORK TOP**

2	956697-2	DEFLECTOR, REAR SST.....	1
5	957566-1	MANIFOLD COVER .....	1
6	956639-G3	WORK TOP .....	1
9	956658-G1	FRONT TOP ASSY .....	1
NS	957065-G1	RISER STUBY .....	1

**\*12" WORK TOP**

2	499935-2	DEFLECTOR, REAR SST.....	1
5	957558-1	MANIFOLD COVER .....	1
6	956639-G4	WORK TOP .....	1
9	499966-G1	FRONT TOP ASSY .....	1
NS	957064-G1	RISER STUBY .....	1

\* ALL PARTS THE SAME AS ON THE 36" EXCEPT AS NOTED.

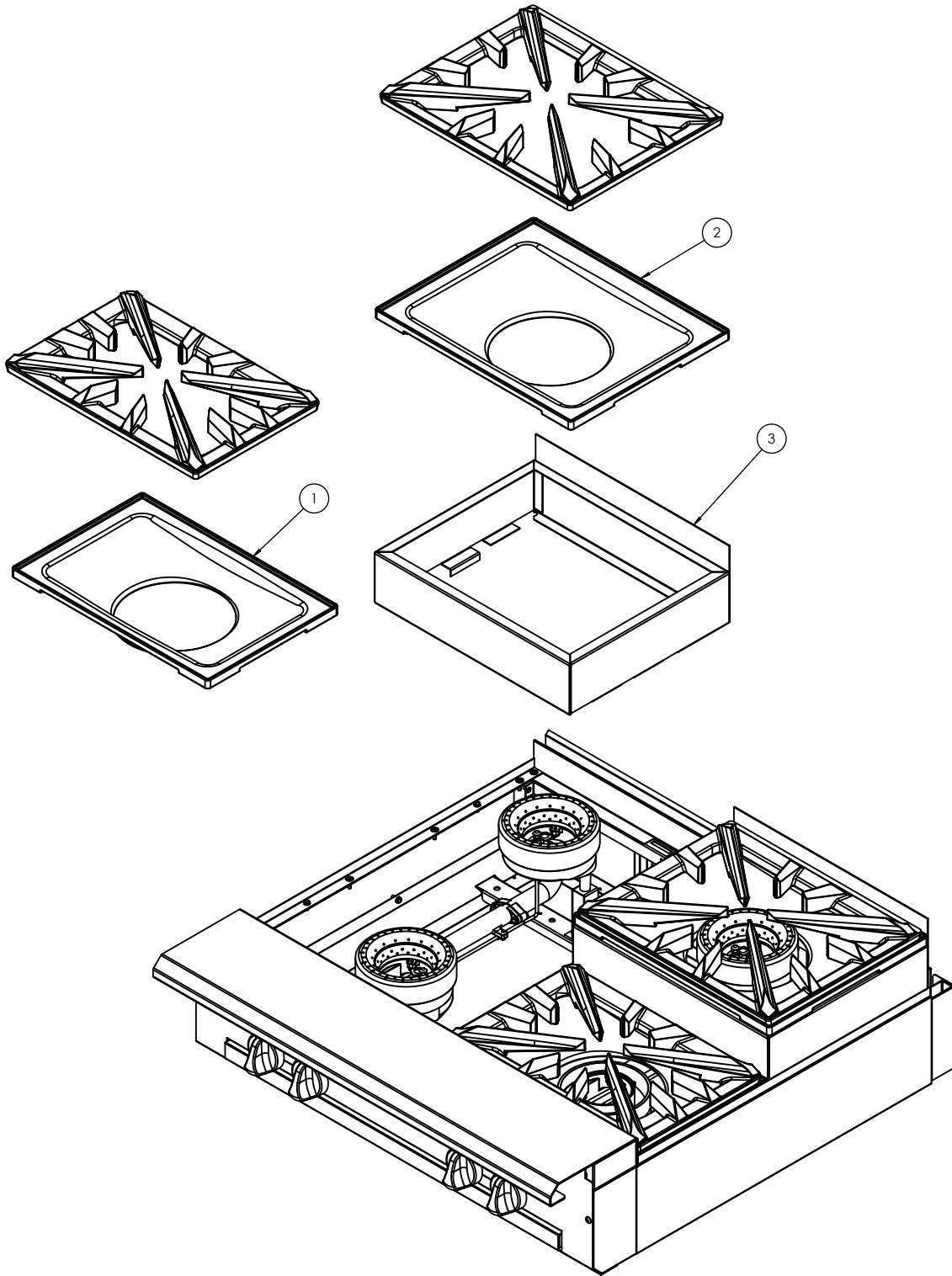

Figure 12

**36" AND 18" STEP UP OPEN TOP BURNER**

ILLUS.	PART NO.	DESCRIPTION	QTY.
Fig. 1			
1	957882-1	BOWL 18" FRONT .....	2
2	957881-1	BOWL 16" REAR .....	2
3	957877-G1	18" STEP UP FRAME .....	2

\* ALL PARTS THE SAME AS ON THE 12" BURNER AND THE 36" 6 open top burner

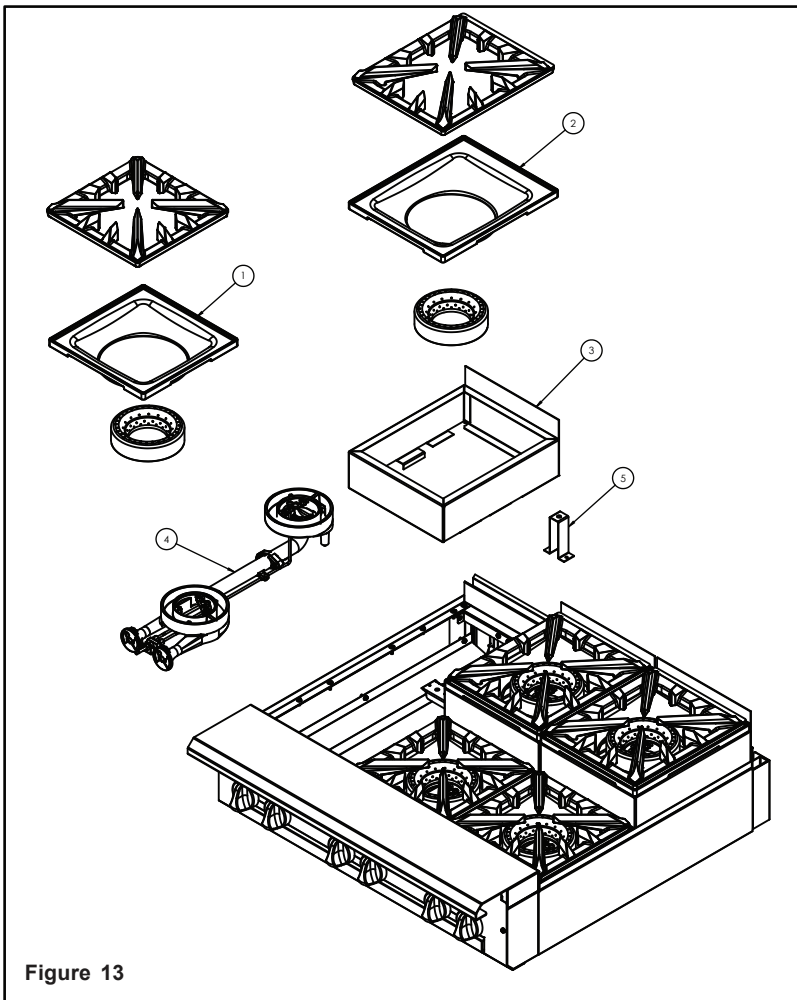

Figure 13

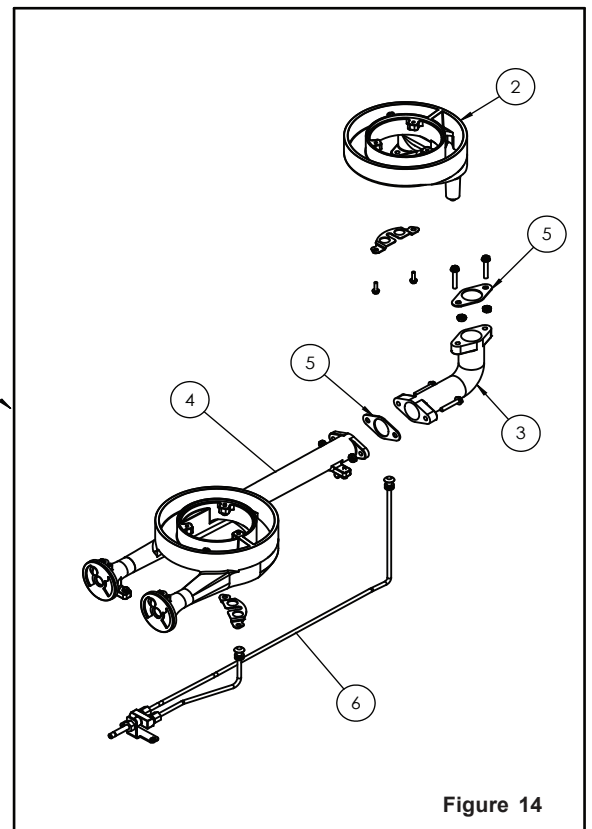

Figure 14

### 36" 6 OPEN TOP STEP UP BURNER

ILLUS.	PART NO.	DESCRIPTION	QTY.
<b>Fig. 13</b>			
1	957878-1	BOWL 12" FRONT.....	1
2	958879-1	BOWL 12" REAR .....	1
3	957877-G1	VENTURI ASSY STEP UP FRAME.....	1
4	957817-G1	VENTURI ASSY STEP UP.....	1
5	957880-1	VENTURI SUPPORT .....	1

### STEP UP BURNER ASSEMBLY

<b>Fig. 14</b>			
1	957817-G1	VENTURI ASSY STEP UP .....	1
2	957826-1	REAR BURNER STEP UP.....	1
3	957825-1	CENTER ELBOW STEP UP .....	1
4	957824-1	FRONT BURNER STEP UP .....	1
5	957823-1	GASKET .....	1
6	499971-2	PILOT QUICK DISCONNECT STEP UP .....	1

\* ALL OTHER PARTS THE SAME AS ON THE 36" 6 OPEN TOP BURNER

