

**VULCAN.**

**SERVICE & PARTS  
MANUAL FOR  
HEAVY DUTY RANGE MATCHING  
GAS FRYERS  
MODELS: HF91E & G, HF92 E & G  
(Formerly 7891E & G, 7892 E & G)**



**VULCAN-HART CORPORATION, P.O. BOX 696, LOUISVILLE, KY 40201-0696, TEL. (502) 778-2791**

# **IMPORTANT**

## **OPERATING, INSTALLING AND SERVICE PERSONNEL**

Operating information for this equipment has been prepared for use by qualified and/authorized operating personnel.

All installation and service on this equipment is to be performed by qualified, certified, licensed and/authorized installation or service personnel, with the exception of any part marked with a □ in front of the part number.

Service may be obtained by contacting the Factory Service Department, Factory Representative or Local Service Agency.

## **DEFINITIONS**

### **QUALIFIED AND/OR AUTHORIZED OPERATING PERSONNEL**

Qualified or authorized operating personnel are those who have carefully read the information in this manual and are familiar with the equipment's functions or have had previous experience with the operation of the equipment covered in this manual.

### **QUALIFIED INSTALLATION PERSONNEL**

Qualified installation personnel are individuals, a firm, corporation or company which either in person or through a representative are engaged in, and are responsible for:

1. The installation of gas piping from the outlet side of the gas meter, or the service regulator when the meter is not provided, and the connection and installation of the gas appliance. Qualified installation personnel must be experienced in such work, be familiar with all precautions required, and have complied with all requirements of state or local authorities having jurisdiction. Reference in the United States of America – National Fuel Gas Code ANSI Z223.1 (Latest Edition). In Canada – Canadian Standard CAN/CGA-B149.1 NAT. GAS (Latest Edition) or CAN/CGA-B149.2 PRO-PANE GAS (Latest Edition).
2. The installation of electrical wiring from the electric meter, main control box or service outlet to the electric appliance. Qualified installation personnel must be experienced in such work, be familiar with all precautions required, and have complied with all requirements of state or local authorities having jurisdiction. Reference: In the United States of America – National Electrical Code ANSI/NFPA No. 70 (Latest Edition). In Canada – Canadian Electric Code Part 1 CSA-C22.1 (Latest Edition).
3. The installation of steam piping from the source of supply to the service inlet of the appliance. Qualified installation personnel must be experienced in such work, be familiar with all precautions required, and have complied with all requirements of state or local authorities having jurisdiction.

### **QUALIFIED SERVICE PERSONNEL**

Qualified service personnel are those who are familiar with Vulcan equipment who have been endorsed by the Vulcan-Hart Corporation. All authorized service personnel are required to be equipped with a complete set of service and parts manuals and stock a minimum amount of parts for Vulcan equipment.

<b>DESCRIPTION</b>	<b>PAGE</b>
DEFINITIONS OF PERSONNEL (Operating, Installation & Service)	(INSIDE FRONT COVER)
INDEX	3
BURNER AND CONTROL INFORMATION	4 & 5
HIGH LIMIT CONTROL	6
SERVICE & TESTING	6 & 7
PROBLEMS & CAUSES	8 & 9
PARTS LIST	10 thru 13

# BURNER AND CONTROL INFORMATION

**Main Burners:** Ultra high input Bunsen type with simple air adjustment. Lift out for cleaning and are interchangeable. Clean with warm mild soapy water and dry completely before remounting. Burners are gang mounted 2 or 3 to a mounting angle. Lock in position with set screw.

Adjust air shutter to normal quiet flame with purple inner cone and blue outer cone. Soft, yellowish flames will produce soot and improper combustion. Hard, hissing flames will produce noisy operation and flashback. Gas orifices are fixed type and require no adjustment.

**Pilot Burners:** Standard production types can be quickly disconnected and removed for service.

**Combination Automatic Valve:** Combining regulator, automatic pilot and electric valve with single knob control of pilot position, on position and off position. Components of this valve type can be quickly removed for service or replacement. The entire valve can be removed for service and replacement, if necessary. 'E' units use 120V-60 HZ, type 'G' units are millivolt type. Remove burners for access to valve.

**Auxiliary shutoff valve:** All units have individual service valve for shut off of gas supply to unit. This valve permits servicing of individual unit without shutdown of gas supply to any other kitchen equipment.

**NOTE:** The unit and its individual shutoff valve must be disconnected from the gas supply piping system during any pressure testing of that system at test pressures in excess of 1/2 PSIG (3.45 K PA.). The appliance must also be isolated from the gas supply piping system by closing it's individual manual shutoff valves during any pressure testing of the gas supply piping system at test pressures equal to or less than 1/2 PSIG (3.45 K PA.) as stated by the American National Standards Z83.13 (latest edition). Copies of this standard are available from the American Gas Association, 1515 Wilson Blvd., Arlington, VA 22209.

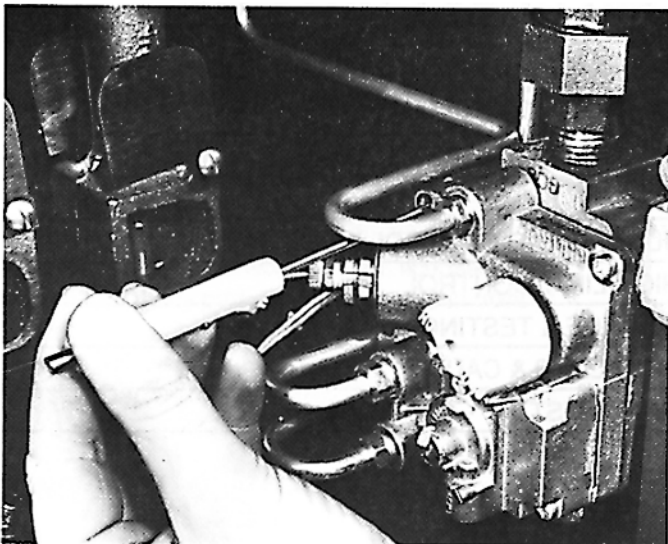
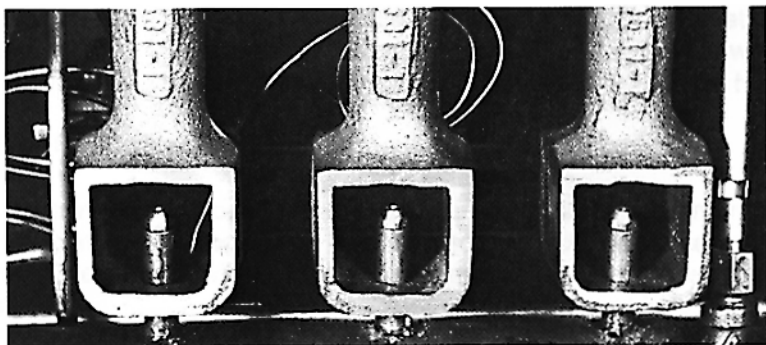

Fig. 2

**Thermostats:** Units are provided with Robertshaw thermostats: "E" models with KX type for 120V, "G" models with GS type for MV control. No service, other than possible calibration, should ever be required. Refer to thermostat data sheet.

**Drain Valves:** Ball type. All steel construction. This type valve does not require cleaning.



Recessed Bullet Nose Orifice Tips—171 x 16-36 Threads  
Fig. 1

# BURNER INFORMATION (Orifice Size, Part No.'s)

## MAIN BURNER ORIFICES

MAXIMUM INPUT PER BURNER	PRESSURE REG.	PART NO.	SIZE	GAS
30,000 BTU/hr.	6 in.	10901-42	No. 42 (.094)	Nat.
30,000 BTU/hr.	10 in.	10901-53	No. 53 (.060)	Propane

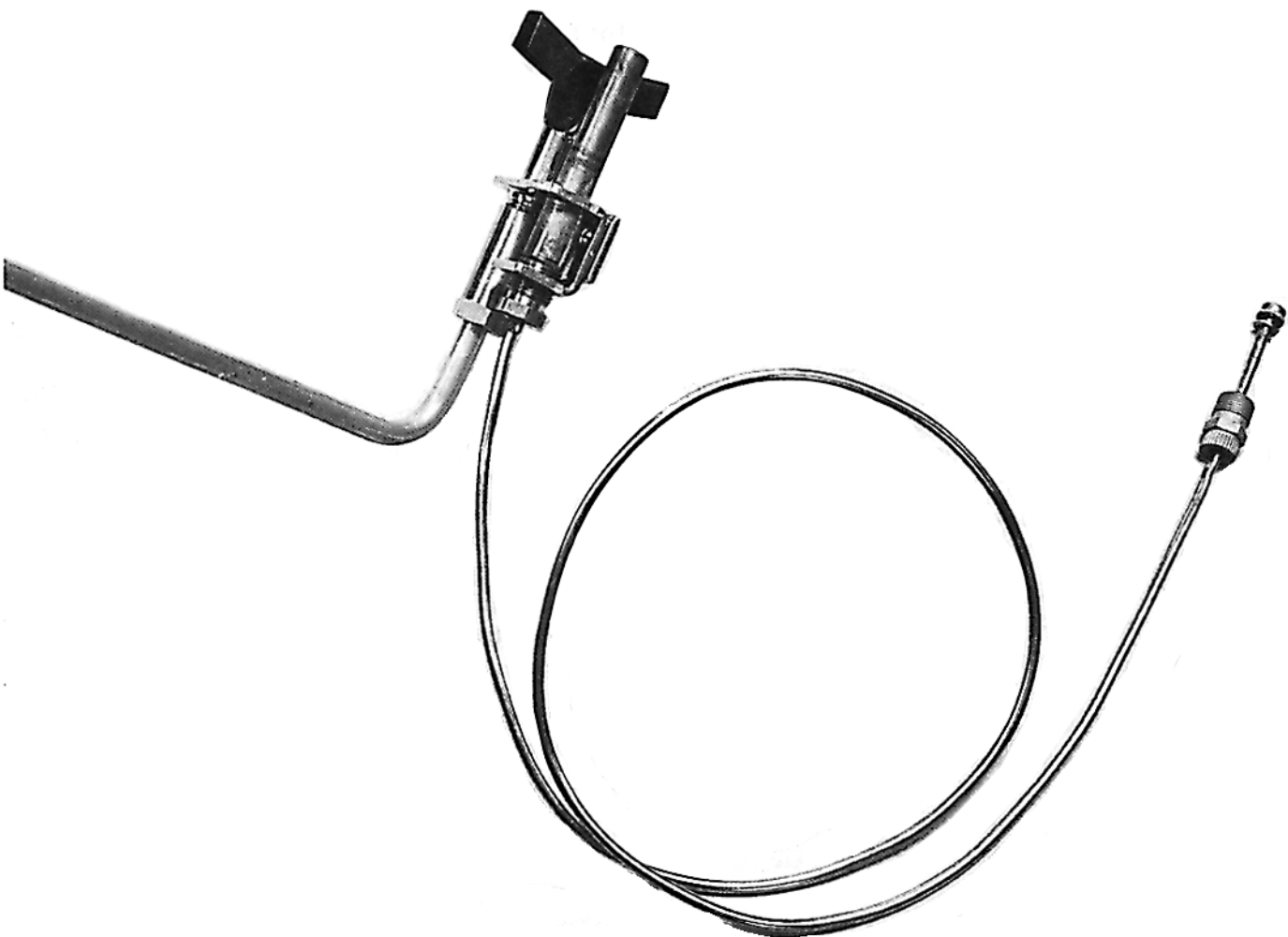

Fig. 3

ITEM	PART NO.	GAS	ORIFICE	ROBERTSHAW NO.	USED ON
<b>PILOT BURNERS</b>					
1	112082-1	Natural	.016	6CH14-10	"E" & "G" Models
2	112082-2	Propane	.010	3CH-10	"E" & "G" Models
<b>THERMOPILE—500 MILLIVOLT</b>					
3	110839-1	Natural, Propane	D.N.A.	51023	"E" & "G" Models

# HIGH LIMIT CONTROL

## High Limit Control

The function of the high limit control is to shut the unit down in the event of a thermostat failure which would allow the frying compound to be overheated. The operating temperature of the high limit control is 450° or 50° higher than the highest temperature allowed by the thermostat when the thermostat is functioning properly.

In the event of a high limit "Shut Down" the entire control system will be put out of operation, and relighting of the pilot will be required.

**NOTE:** If High Limit "Shutdown" should occur, the High Limit Control is not to be bypassed in any way to put fryer back into service.

**DO NOT** attempt to re-light the pilot until the temperature of the cooking oil has lowered to approximately 350°.

Thermostat service is indicated if the high limit cut off persists.

The high limit control is located behind the manifold pipe in the lower cabinet.

## SERVICE AND TESTING INFORMATION

### TESTING MILLIVOLTAGE SYSTEM "G" UNITS

Millivolt Meter Required For Powerpile and Pilot Outage Protection Device Tests.

#### 1. POWERPILE TEST

Turn thermostat to OFF. Disconnect Powerpile lead from control and clamp leads to Powerpile Tip and Capillary. Plug in meter leads to 1000 MV scale. Turn control lever to Pilot position and light pilot burner. Hold in manually for 2 to 4 minutes until meter needle has steadied out. Meter reading should be no less than 150 millivolts closed circuit. If less replace the thermopile.

#### 2. OPERATOR MAGNET

Turn thermostat to OFF. If unit is not in operation, turn control lever to PILOT position and light pilot burner. Allow 2 to 4 minutes for Powerpile to reach maximum output. Turn control lever to OFF to extinguish pilot. Meter reading will slowly decrease as Powerpile is cooling. Read meter when drop-out click of Pilot Outage Protection Device operator is heard. Replace operator magnet or entire valve if reading is lower than 40 MV closed circuit.

#### 3. THERMOSTAT CHECK

**A. "KX" Thermostat - 120 Volt System Used on Models HF91E & HF92E.**

Turn thermostat to OFF. If unit is not in operation, turn control lever to Pilot position and light pilot burner. Allow time for Powerpile to reach maximum output. Turn control lever to ON position. Turn thermostat on to temperature setting above that of frying compound. If main burners do not light turn thermostat back to OFF. Remove front panel screws and drop front panel away from unit to examine terminal connections to thermostat. If loose, tighten and recheck thermostat operation. If thermostat fails to operate main burners, jump thermostat terminals with screwdriver blade, or other. If main burners then operate, it indicates faulty thermostat.

**B. "GS" Thermostat for millivoltage system. Used on HF91G & HF92G Models.**

Turn thermostat to OFF. If unit is not in operation, turn control lever to Pilot position and light pilot burner. Allow time for Powerpile to reach maximum output. Turn control lever to ON position. Turn thermostat on to temperature setting above that of frying compound. If main burners do not light, turn thermostat back to OFF. Test as follows:

Check for gas flow through ¼" bleed tubes. Bleed gas is routed from overtemperature shutoff valve to thermostat back to the valve. Tubes must be open for free gas flow. If tubes are open, remove tube at outlet of thermostat and blow into this tube. If the main burners cycle on, replace the thermostat. If the main burners do not come on, replace the overtemperature shutoff valve.

**IMPORTANT:** If main burner gas is on and can not be controlled or cycled with the thermostat a gas leak in the bleed gas system is indicated.

**NOTE:** In the event that the frying compound temperature reaches 450° the High Limit Control will shut down the system. See High Limit Control Instructions above.

**NOTE:** When replacing thermostat make sure excess capillary tubing from bulb is coiled neatly out of burner flame area. Do not allow capillary lead to touch side of heat exchanger tubes.

#### CALIBRATION

Each Model KX electric thermostat and "GS" gas thermostat is adjusted at the factory and calibrated on precision instruments to control temperatures accurately. Adjustment or recalibration is not needed unless the thermostat has been mishandled in transit or changed or abused while in service.

# SERVICE AND TESTING INFORMATION (Cont.)

---

## To check Calibration

1. Use a potentiometer or good grade thermometer to determine temperature at the location where temperature regulation is required. **NOTE:** Do not use Bi Meter Thermometer.
2. Turn the thermostat knob to a medium temperature setting.
3. Allow enough time for temperature to stabilize, or until several temperature readings are identical.
4. Read thermometer to see if it agrees with dial setting. The difference between dial setting and thermometer reading should not be more than 3% of the total temperature range on the thermostat dial.
5. If difference in reading is more than 3%, recalibrate the thermostat as follows:

Remove thermostat knob.

Rotate screw-in stem clockwise to decrease and counterclockwise to increase temperature. One quarter turn equals 18 degrees.

Replace knob, reset medium temperature setting, and recheck.

## FRY TANK REPLACEMENT PROCEDURE

1. Turn the thermostat to off. Unplug electric cord on "E" Models.
2. Loosen burner lock screws and lift out burners.
3. Turn service valve off.
4. Disconnect pilot burner and demount from tank.
5. Lift off or swing up back splash basket and hanger and remove (3) tank screws.,
6. Front top is fastened from underside with (2) nuts and washers, and 2 additional screws on top. Unfasten front control for access to front top nuts and remove front top.
7. Remove (3) screws at flue box rear and lift off flue box and flue parts. (Remove backguard or high shelf front on HF series fryers.)
8. Tank can now be lifted out of unit. HF series fryers require additional removal of rear cross brace over tank flue box. Cross brace comes out or in with tank—not separately. After removal of cross brace screws, let cross brace lay on tank flue box when lifting out tank. Replace tank flue box when installing tank.

**NOTE:** Transfer flue box from old tank to new when replacing tank.

# PROBLEMS AND CAUSES

PROBLEM	CAUSE
Fryer not working to normal high speed - the temperature of the frying compound drops too far and excessive recovery time required.	Insufficient gas supply to unit—supply lines need correction.
	Ventilating system pulling heat out of the Heat Exchanger and Flue—Box Ventilating system requires correction.
	Flue blockage; burner flames not drawing in the tubes—remove blockage and check venting.
	Overloading capacity—need larger fryer.
Pilot won't stay lit—shuts off fryer.	Defective thermopile or loose or dirty connection of same.
	Defective overtemperature shutoff valve.
	Pilot burner orifice and air openings need cleaning/adjustment.
Rapid frying compound breakdown—crumbs and specks in frying compound.	Excessive temperature settings (over 375°).
	Frying compound not being filtered regularly.
	Incorrect preparation breaded foods. — Don't use salt. — Allow breading time to adhere to foods. — Loose flour falls into frying compound from hands.
	Don't add strainings or drippings from meat fats to frytank frying compound.
	Use correct frying compound and follow temperature recommendations.
	Dirty frytank — sludge and carbon buildup gives bad taste and hastens breakdown.
	Take out 10 to 15% of the frying compound and fill with fresh frying compound. Use compound taken out in other cooking. Keeps acid buildup down.
	Check thermostat settings with thermometer in frytank periodically. Thermostat may become out of calibration and give excess temperature at low settings.
Leaking frytank.	Frying compound will follow metal surfaces up and down. Foam over by worn out frying compound permits compound to drip from frytank surfaces giving appearance of leak.
	Careless draining procedure without turning off burners to prevent operation with empty tank can damage tank joints.
	Carbon buildup in dirty frytank causes rapid attack on frytank by promoting acid formulation. Use of solid frying compound causing warpage/cracking of frytank.

# PROBLEMS AND CAUSES (Cont.)

PROBLEM	CAUSE
Pilot burner lights and pilot outage protection device "holds in" but "drops out" when thermostat is turned on.	<p>Possible High Drop Out in pilot outage protection</p> <p>Possible Low Output Powerpile cartridge.</p> <p>Possible loose wiring and terminal connections ("E" models).</p> <p>Pilot flame adjusted too low—increase.</p> <p>Check all wiring and connections. See that terminals are not touching another terminal and connection of wire to pilot outage operating house in tight and clean.</p> <p>See testing Powerpile cartridge and pilot outage operator with Millivolt Meter for an accurate check for these items. If meter is not available, replace automatic pilot magnet or entire valve. If unit will still not operate, replace Powerpile.</p>
Pilot burner lights and pilot outage protection device "holds in" but unit will not operate when Thermostat is turned ON.	<p>Possible faulty Thermostat.</p> <p>Possible faulty Diaphragm Valve.</p> <p>Possible loose wiring and terminal connections.</p> <p>High Limit Shutdown (See High Limit Control Instructions). Check wiring as in item above—See testing of Diaphragm Valve and Thermostat.</p>
Unit comes ON when control lever is turned ON even though Thermostat is OFF.	<p><b>"G" Control System (Millivolt)</b>            Defective Thermostat (Robertshaw "GS").            Leak in Bleed Gas System—Check tube fittings at Thermostat and Pilot Outage Protection Valve.</p> <p><b>"E" Control System (120V)</b>            Defective Thermostat (Robertshaw "KX").            Thermostat terminals touching one another.            Thermostat Wire Insulation out and bare wire grounded to unit.</p>
Pilot burner flames adjusted properly but fluctuate to very low and blow out easily.	<p>Check gas pressure at sub-manifold fitting on fryer with unit and all other equipment on same gas line in operation.</p> <p>Pressure at sub-manifold (pipe on which burners are mounted) should not be less than 3" W.C. (water column) for (natural) gas and 9.5" W.C. for (propane) gas. Local gas utility will make check if requested.</p>

# REPLACEMENT PARTS LIST

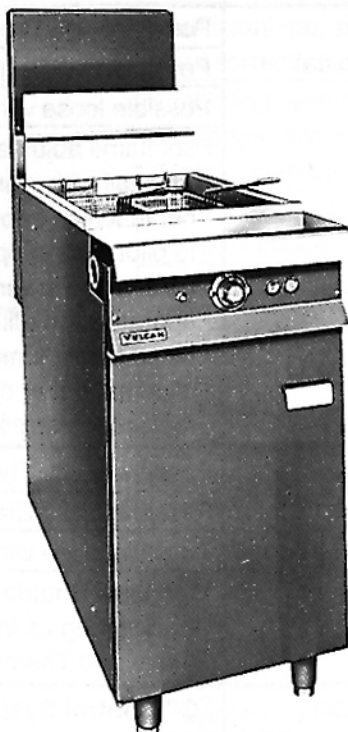

**MODEL HF92E**

## **REPLACEMENT PARTS ORDERING FOR MODELS HF91E, HF92E & MODELS HF91G & HF92G**

The following information must accompany a replacement parts order or it cannot be filled.

- A. MODEL AND STYLE NUMBER,
- B. TYPE OF GAS.
- C. APPLIANCE FINISH, PAINTED, STAINLESS STEEL, ETC. (IF APPLICABLE TO PART TO BE REPLACED.)

This information can be found on the instruction plate on front of the unit.

Parts may be ordered from your dealer, service agency, or service depot.

# REPLACEMENT PARTS LIST (Cont'd)

ITEM	DESCRIPTION	HF91G	HF91E	HF92G	HF92E	DETAIL PHOTO
1	THERMOSTAT "GS"	110837-2		110837-2		A & C
2	THERMOSTAT "KX"		110687-1		110687-1	A & D
<input type="checkbox"/> 3	KNOB - THERMOSTAT		108659-2		108659-2	A
<input type="checkbox"/> 4	KNOB - THERMOSTAT	112195-1		112195-1		A
5	AMBER SIGNAL LIGHT		108677-1		108677-1	A & D
6	CLEAR SIGNAL LIGHT		108677-2		108677-2	A & D
7	PUSH BUTTON SWITCH		108660-1		108660-1	A & D
<input type="checkbox"/> 8	DOOR HANDLE	108615-1	108615-1	108615-1	108615-1	A
<input type="checkbox"/> 9	HINGE - TOP	112779-2	112779-2	112779-2	112779-2	A
<input type="checkbox"/> 10	HINGE BOTTOM	112779-1	112779-1	112779-1	112779-1	A
<input type="checkbox"/> 11	DOOR CATCH - MAGNET	108834-1	108834-1	108834-1	108834-1	E & F
12	REAR SPLASH - HANGER ASSEMBLY	108646-G4	108646-G4	108646-G2	108646-G2	A
<input type="checkbox"/> 13	FRYBASKET - TWIN	108654-1	108654-1	108654-4	108654-4	A
<input type="checkbox"/> 14	FRYBASKET - SINGLE	111378-2	111378-2	111378-1	111378-1	—
<input type="checkbox"/> 15	CRUMB SCREEN	110738-1	110738-1	108651-2	108651-2	—
16	PILOT BURNER (NATURAL)	112212-1	112212-1	112212-1	112212-1	B, E, & F
17	PILOT BURNER (PROPANE)	112212-2	112212-2	112212-2	112212-2	B, E, & F
18	THERMOPILE	110839-1	110839-1	110839-1	110839-1	B
20	PILOT OUTAGE VALVE (PROPANE)	110841-2	110841-4	110841-2	110841-4	E & F
21	ADAPTOR WIRE	110838-G1	110838-G1	110838-G1	110838-G1	E & F
22	HIGH LIMIT CONTROL	110840-2	110840-2	110840-2	110840-2	E
23	SERVICE VALVE	108604-3	108604-3	108604-3	108604-3	E & F
24	BURNER	108174-2	108174-2	108174-2	108174-2	F
25	ORIFICE - BURNER (NAT.)	10901-42	10901-42	10901-42	10901-42	E
27	ORIFICE - BURNER (PROPANE)	10901-53	10901-53	10901-53	10901-53	E
	(Prior To Style 875B)					
28	FRYTANK ASSEMBLY - STANDARD	109438-G1	109438-G1	109438-G9	109438-G9	G
29	FRYTANK ASSEMBLY - STAIN ST'L.	109438-G2	109438-G2	109438-G10	109438-G10	G
	(Style 875B)					
28a	FRYTANK ASSEMBLY - STANDARD	112970-G1	112970-G1	112970-G3	112970-G3	—
29a	FRYTANK ASSEMBLY - STAIN ST'L	112970-G2	112970-G2	112970-G4	112970-G4	—
30	TUBE RADIANTS	108633-G1	108633-G1	108633-G1	108633-G1	
31	DRAIN VALVE - GATE TYPE	110792-1	110792-1	110792-1	110792-1	G
32	DRAIN VALVE - BALL TYPE	109408-1	109408-1	109408-1A	109408-1	E & F
33	ELECTRIC CORD		105016-1		105016-1	—
	(Used Only Prior To Style 875B)					
34	FITTING - THERMO BULB TO FRYTANK	105701-13	105701-13	105701-13	105701-13	G
35	FITTING - HI-LIMIT BULB TO FRYTANK	111977-1	111977-1	111977-1	111977-1	G
36	FLUE BOX ASSEMBLY	108634-G13	108634-G13	108634-G14	108634-G14	G

PARTS NOT REQUIRING REPLACEMENT BY SERVICE AGENCY.

# REPLACEMENT PARTS LIST (Cont'd)

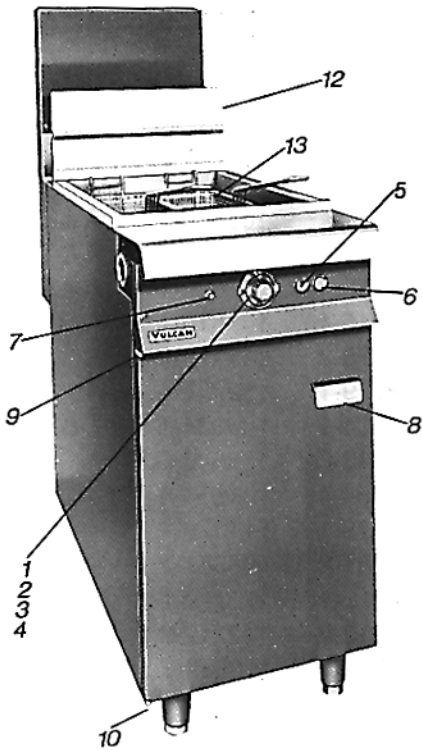

Detail A

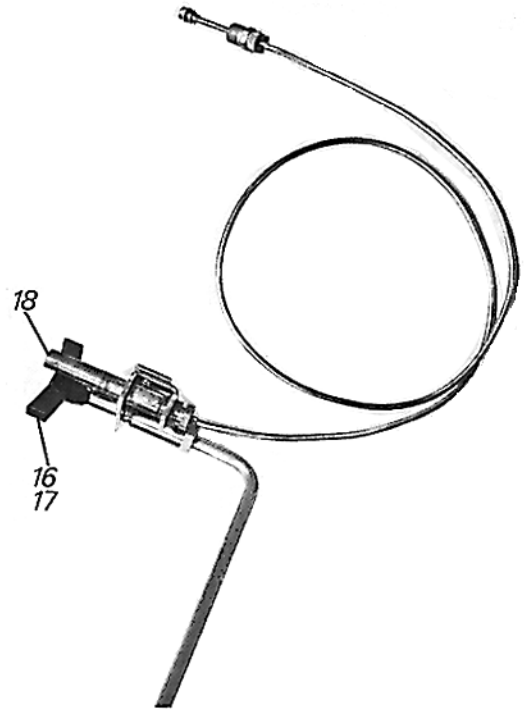

Detail B

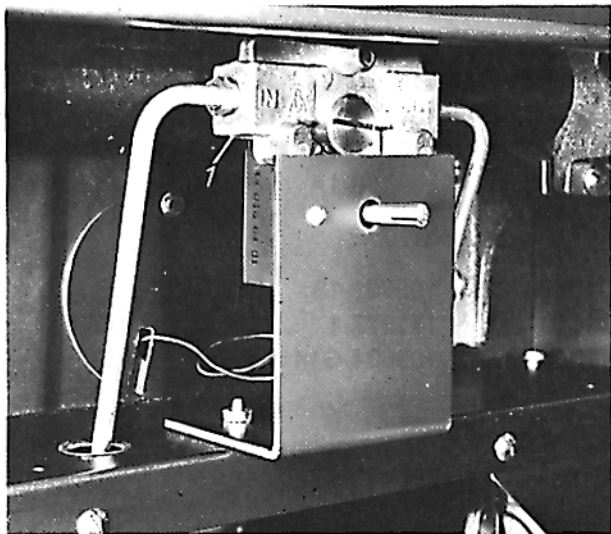

Detail C

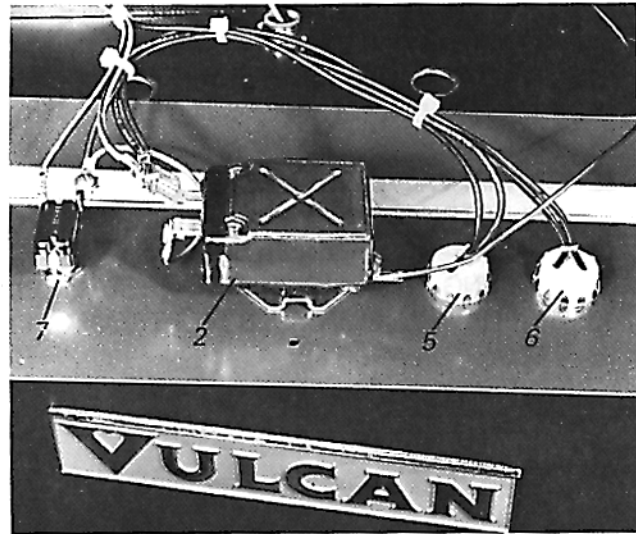

Detail D

# REPLACEMENT PARTS LIST (Cont'd)

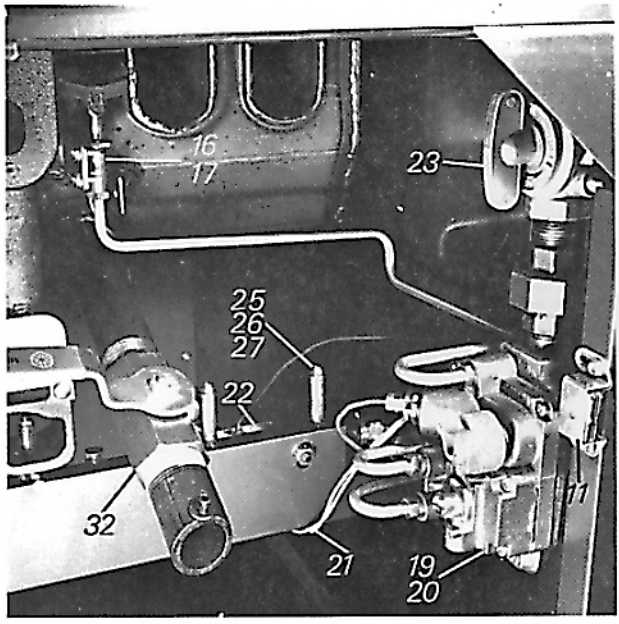

Detail E

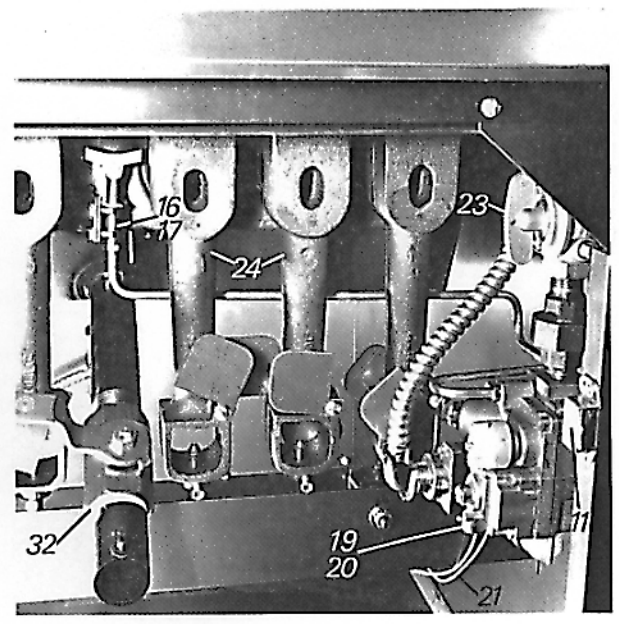

Detail F

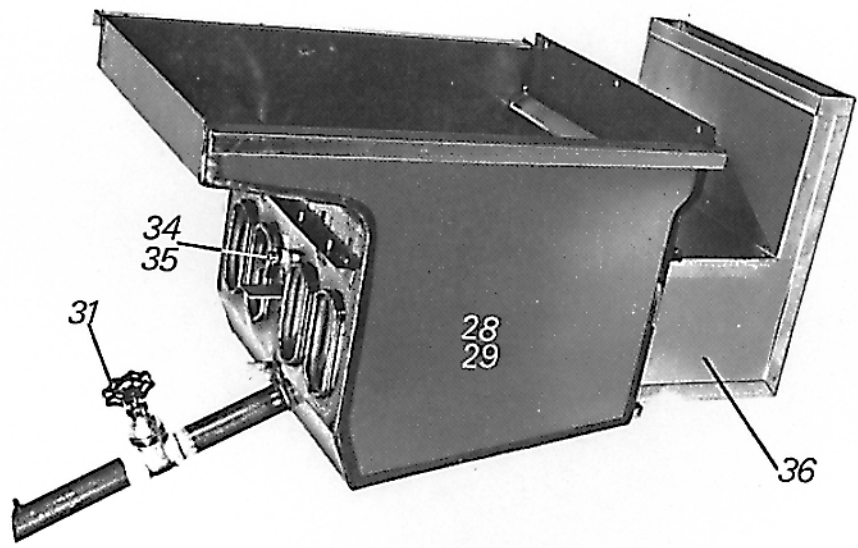

Detail G

THIS  
PAGE  
INTENTIONALLY  
LEFT  
BLANK

THIS  
PAGE  
INTENTIONALLY  
LEFT  
BLANK

THIS  
PAGE  
INTENTIONALLY  
LEFT  
BLANK