

VULCAN

CATALOG OF REPLACEMENT PARTS

ES, EL & ET STEAM JACKETED KETTLES

MODELS

<i>ES25</i>	<i>ML-52642</i>
<i>ES30</i>	<i>ML-52643</i>
<i>EL40</i>	<i>ML-52644</i>
<i>ES60</i>	<i>ML-52645</i>
<i>EL80</i>	<i>ML-52646</i>
<i>ET100</i>	<i>ML-52647</i>
<i>ET125</i>	<i>ML-52648</i>
<i>ET150</i>	<i>ML-52649</i>



For additional information on Vulcan-Hart Company or to locate an authorized parts and service provider in your area, visit our Web site at www.vulcanhart.com

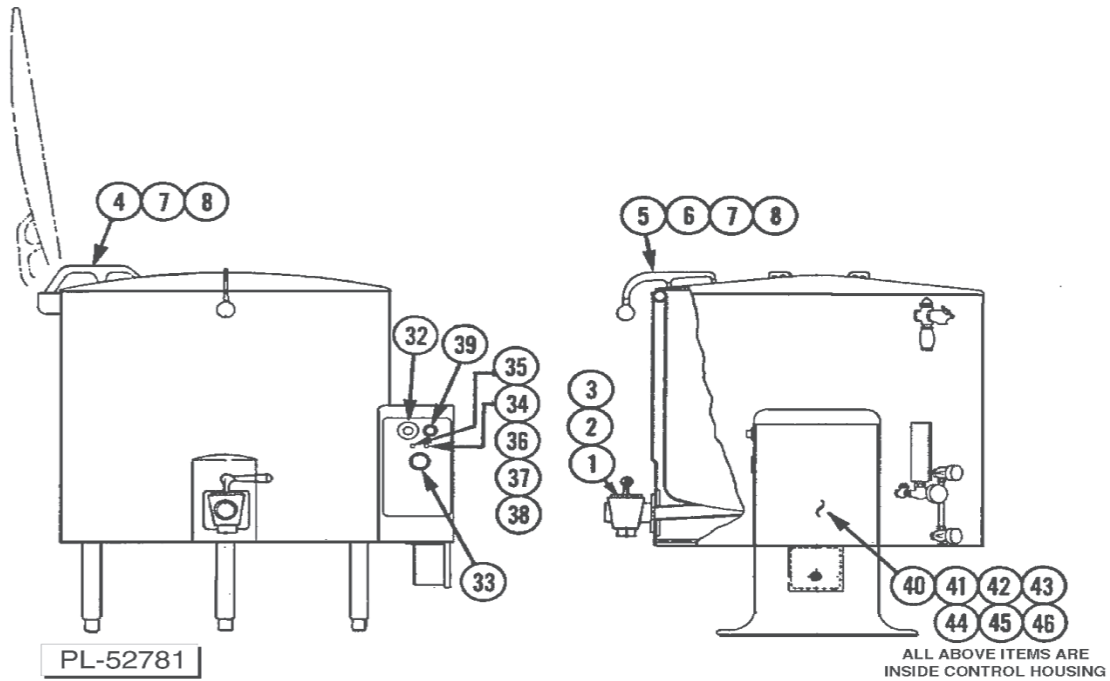
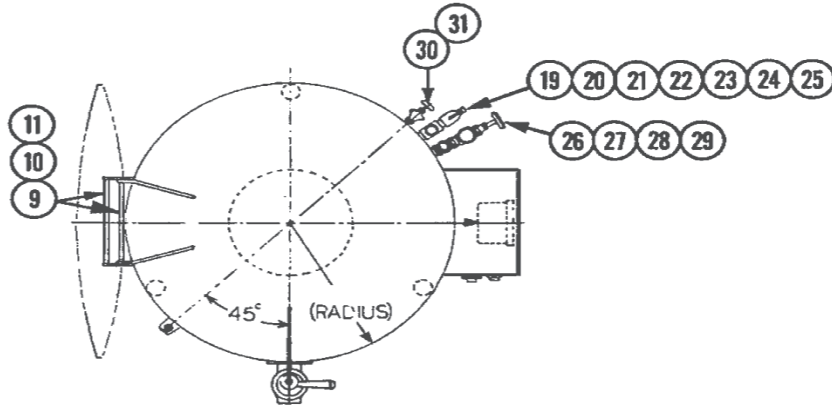

REPLACEMENT PARTS

ILLUS.	PART NO.	NAME OF PART	AMT.
PL-52781			
1	00-817900	2" Draw Off Valve (w/4 Bolt Flange) (New Style)	1
2	00-831713	Gasket for 1 1/2" Draw Off Valve (w/2 Bolt Flange) (Old Style)	1
	00-831713	Gasket for 2" Draw Off Valve (w/2 Bolt Flange) (Old Style)	
	00-833394	Gasket for 2" or 3" Draw Off Valve (w/4 Bolt Flange) (New Style)	
3	SC-119-36	1 1/2" Draw Off Valve Mounting Screw, 1/2-20 x 1 1/4" (Old Style)	2
	SC-119-36	2" Draw Off Valve Mounting Screw, 1/2-20 x 1 1/4" (Old Style)	2
	SC-119-38	2" or 3" Draw Off Valve Mounting Screw, 5/8-18 x 1 1/4" (New Style)	4
4	00-817615	Cover Hinge LH	1
	00-817615-00001	Cover Hinge RH	1
5	00-817168-00002	Cover Handle Casting	1
6	00-833213	Cover Handle Ball	1
7	SC-041-50	Screw, Handle & Hinge to Cover 1/4-20 x 1/2"	6
8	00-833211	Plastic Washer (for Item 7)	6
9	00-817115-00001	Cover Hinge & Stop Rod - 20 1/2" O.D. Kettle	2
	00-817115-00002	Cover Hinge & Stop Rod - 25" O.D. Kettle	
	00-817115-00003	Cover Hinge & Stop Rod - 29" O.D. Kettle	
	00-817115-00004	Cover Hinge & Stop Rod - 33" O.D. Kettle	
	00-817115-00005	Cover Hinge & Stop Rod - 36 1/2" O.D. Kettle	
10	NS-025-04	Hinge Rod Acorn Nut, 1/4"-20	4
11	WL-013-14	Lock Washer (for Item 10) INT 1/4"	4

REPLACEMENT PARTS (CONT.)

ILLUS.	PART NO.	NAME OF PART	AMT.
PL-52781			
19	00-841496-00001 FP-084-16	Pressure Relief Valve ³ / ₄ " (15 Lb.) ³ / ₄ " x ¹ / ₂ " Reducing Bushing	1
20	00-833239	Air Vent ³ / ₄ "	1
21	00-833238	Vacuum Breaking Check Valve, ¹ / ₂ "	1
22	FP-083-92	Cross ³ / ₄ "	1
23	FP-054-27	³ / ₄ " Close Nipple	1
24	FP-054-08	¹ / ₂ " Close Nipple	1
25	FP-084-16	³ / ₄ " x ¹ / ₂ " Reducing Bushing	1
26	00-836082-00001	Fill Pipe Assembly	1
27	00-833501	Fill Valve	1
28	00-833648	Check Valve	1
29	FP-054-08	¹ / ₂ " Close Nipple	2
30	00-833493-00011	Gauge Glass With Washers	1
31	00-833493	Gauge Glass Assembly Complete	1
32	00-833220	Thermostat	1
33	00-833152	Pressure Gauge	1
34	00-833393-00011	"Power-On" Signal Light (Red)	AR
35	00-833393-00010	"Heat-On" Signal Light (Amber)	AR
36	00-833483	Signal Light Gasket	2
37	00-833176	Signal Light Clamp Bar	1
38	SC-093-05	Clamp Bar Screw, 8-32 x ¹ / ₂ "	1
39	00-906996 00-833392	ON/OFF Switch Block (Normally Open)	1
		ON/OFF Operating Switch	1
40	00-833488	Pressure Limit Switch	1
41	00-833486	Pressure Limit Switch Bracket	1
42	00-880030 00-833196-00011	Low Water Cut Off, Complete	1
		Low Water Cut Off, Switch Only	1
43	00-880410	Heating Element Gasket	2
44	SC-113-18	Heating Element Screw, ⁵ / ₁₆ -18 x 1	8
45	00-832611-00013	Heating Element (9 kW, 208 V)	2
	00-832611-00014	Heating Element (9 kW, 240 V)	2
	00-832611-00015	Heating Element (9 kW, 480 V)	2
	00-832611-00016	Heating Element (12 kW, 208 V)	2
	00-832611-00017	Heating Element (12 kW, 240 V)	2
	00-832611-00018	Heating Element (12 kW, 480 V)	2
	00-832611-00019	Heating Element (18 kW, 208 V)	2
	00-832611-00020	Heating Element (18 kW, 240 V)	2
	00-832611-00021	Heating Element (18 kW, 480 V)	2
	00-832611-00022	Heating Element (21.6 kW, 208 V)	2
	00-832611-00023	Heating Element (21.6 kW, 240 V)	2
	00-832611-00024	Heating Element (21.6 kW, 480 V)	2
	00-832611-00025	Jumper Strap for Element	AR
	00-841496-00002	10 lb. Pressure Relief Valve	1
	00-833220-00011	Thermostat Knob	1
	00-834472	16" Leg	3
46	00-836804	Contactors 40-amp (Use on 18 kW, 208-240/60/1 and 24 kW, 240 V, 1 Ph & 208-240/60/3)	2
	00-836805	Contactors 50-amp (Use on 18 & 36 kW, 240/60/3 and 24 kW, 208/60/1)	2
	00-836806	Contactors 60-amp (Use on 18 & 36 kW, 208/60/3 and 43.2 kW, 208-240/60/3)	2
	00-881654	Contactors 40-amp, 3 Ph (Use on 18 & 24 kW, 480/60/3)	1
	00-881655	Contactors 50-amp, 3 Ph (Use on 36 kW, 480/60/3)	1
	00-881656	Contactors 60-amp, 3 Ph (Use on 43.2 kW, 480/60/3)	1
	00-836807	Box-Contactors Bracket	1
	00-833651	6 oz. Bottle of Rust Inhibitor (2 ozs. Per Charge)	
	00-833652	Faucet Lubricant in Aerosol Can (1 can)	
	00-833525	Control Circuit Transformer	
	00-831912-00011	Gasket—Extrusion	
	00-833515	Ring (1 ¹ / ₄ Seal)	
	00-843927	1 ¹ / ₂ " Strainer	
	00-843928	2" Strainer	
	00-843929	3" Strainer	
	00-836799-00010	Handle, Draw Off Valve (Black)	

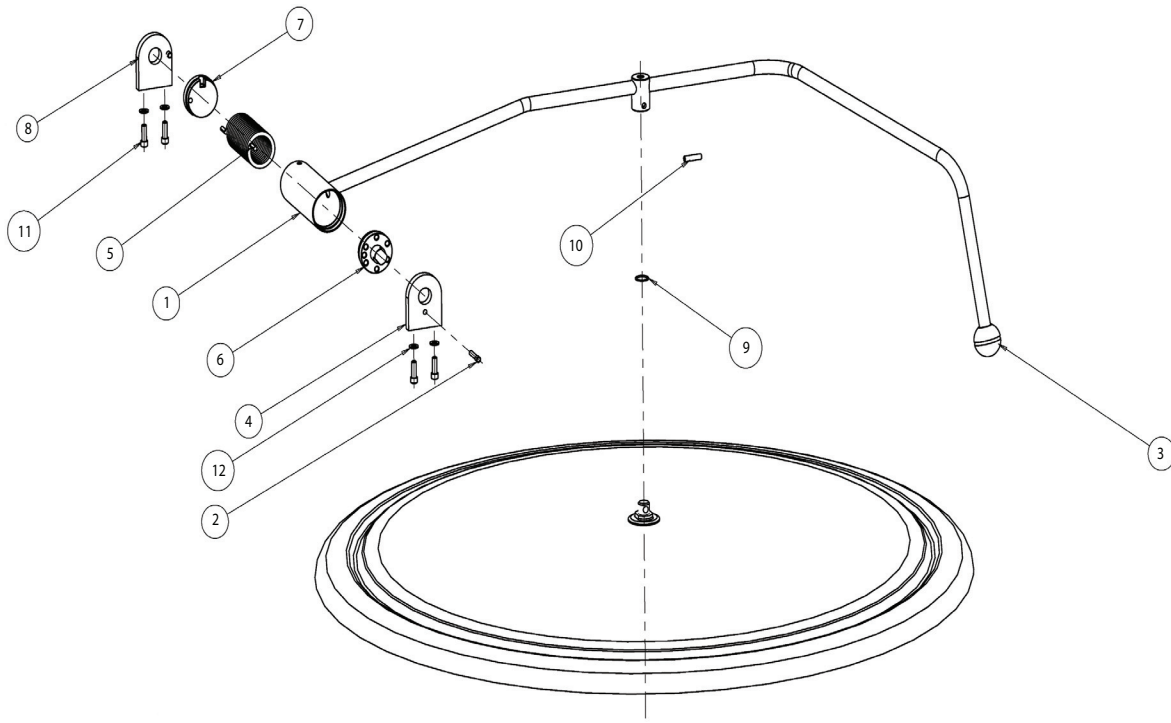

SPRING ASSIST COVER

LLUS. Figure 2	PART NO.	NAME OF PART	AMT.
1	00-853278-00001	Handle Weldment, 29" (25, 30, 40 Gallon Kettles)	1
	00-853279-00001	Handle Weldment, 36" (60, 80, 100, 125, 150 Gallon Kettles)	1
2	00-853284-00001	Pin, Lock	1
3	00-853285-00001	Knob, Press On	1
4	00-853286-00001	Plate, Front	1
5	00-853289-00001	Spring, Torsion	1
6	00-853292-00001	Disc, Tension, Adjustment	1
7	00-853293-00001	Disc, Rotary, Stop	1
8	00-855220-00002	Plate, Rear Weldment	1
9	OR-001-07	"O" Ring (Per Standard 016)	1
10	RP-004-31	Pin, Roll .250 X 1.000	1
11	SC-110-98	1/4-20 x 3/4, S.H.C.S., SST	4
12	WL-006-17	Washer, Lock, Helical 1/4	4
13	00-544268	Lubriplate FGL-2 USDA HI (Ounce)	2

RECOMMENDED SPARE PARTS

PART NO.	NAME OF PART	AMT.
00-833501	Fill Valve	1
00-833648	Check Valve	1
00-833238	Vacuum Breaker Check Valve	1
00-833239	Air Vent	1
00-817098	Gauge Glass Assy.	1
00-880030	LWCO	1
00-833393-00010	Signal Light (Amber)	1
00-833393-00011	Signal Light (Red)	1
00-906996	Contact Block (Normally Open)	2
00-833392	ON/OFF Operator Switch	2
00-833652	Valve Lubricant (Petro Gel)	1
00-833220	Thermostat	1
00-833220-00011	Thermostat Knob	1
00-833488	Pressure Limit Switch	1
00-833152	Pressure Gauge	1
00-880410	Element Gasket	2
00-832611-00013	Element (208 V, 9 kW)	1
00-832611-00014	Element (240 V, 9 kW)	1
00-832611-00015	Element (480 V, 9 kW)	1
00-832611-00016	Element (208 V, 12 kW)	1
00-832611-00017	Element (240 V, 12 kW)	1
00-832611-00018	Element (480 V, 12 kW)	1
00-832611-00019	Element (208 V, 18 kW)	1
00-832611-00020	Element (240 V, 18 kW)	1
00-832611-00021	Element (480 V, 18 kW)	1
00-841496-00001	Valve, 15# Pressure Relief	1