



10TA
TUBE-ICE[®]
MACHINE

(Includes model P18FXT)

Manual Part Number [12A4171M08](#)
Revision 3

Service Manual
\$50⁰⁰

NOTICE

This manual is the property of the owner of this particular Tube-Ice® machine.

Model # _____ Serial # _____.

It is to be left on the premises with this machine at all times. After start-up, it should be stored in a safe place where it can be readily available when needed for future reference in maintaining troubleshooting or servicing.

Failure to comply with this notice will result in unnecessary inconvenience and possible additional expenses.

This manual is intended as an informational tool for the installation, operation, maintenance, troubleshooting, and servicing of this equipment. If an existing situation calls for additional information not found herein, we suggest that you contact your distributor first. If further assistance or information is needed, please feel free to contact the factory at 502-635-3000 or FAX at 502-635-3024.

IMPORTANT: To activate the machine warranty, the Product Registration Form **MUST** be completed and returned to the factory promptly after the official start-up. Product Registration Form is located in the Owners Packet or can be found online at www.vogtice.com/registration.htm.

Please return to: VOGT ICE®, LLC
Suite #19
1000 W. Ormsby Ave.
Louisville, KY 40210

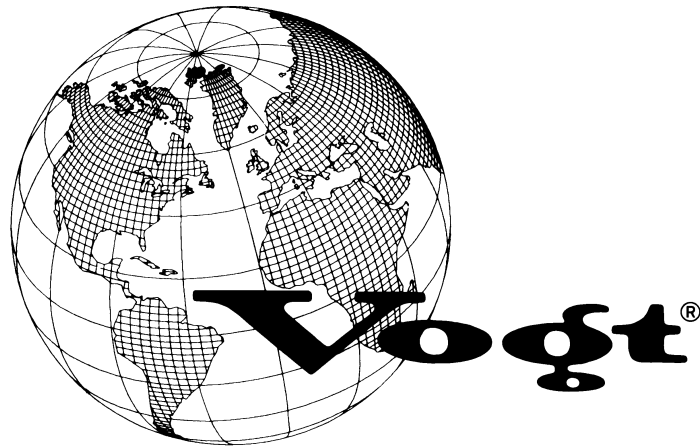

**VOGT ICE® , LLC, located in
Louisville, Kentucky since 1880.**

Sales - (800) 959-8648

Service - (502) 635-3000

Parts - Your Local Distributor

Call your local distributor **first** for all of your parts and service needs.

Since 1880, Manufacturers of Quality
Tube-Ice® Machines

Vogt®
Tube-Ice® Machines

Installation, Service Manual and Parts Catalog #12A4171M08
10TA Model

TABLE OF CONTENTS

Vogt[®] TUBE-ICE[®] MACHINES Model 10TA (Includes P18FXT)

	Page No.
<u>1. INTRODUCTION</u>	
A Brief History Of Our Company	1-1
Vogt Energy-Savings Tube-Ice [®] Machines	1-1
Preview	1-1
Important Safety Notice.....	1-2
Special Precautions To Be Observed When Charging Refrigeration Systems.....	1-2
Safety Symbols and What They Mean.....	1-3
Assembly Drawing Model 10TA (P18FXT) Air-Cooled, FIGURES 1-1, 1-2, & 1-3	1-4, 1-5, 1-6
Assembly Drawing Model 10TA (P18FXT) Water Cooled, FIGURES 1-4, 1-5, & 1-6	1-7, 1-8, 1-9
<u>2. RECEIPT OF YOUR TUBE-ICE MACHINE</u>	
Inspection	2-1
Safety Valves.....	2-1
Machine Room	2-1
Storage (prior to installation and start-up)	2-2
Vogt Model Nomenclature, FIGURE 2-1.....	2-2
<u>3. INSTALLING YOUR TUBE-ICE MACHINE</u>	
Piping and Drain Connections, TABLE 3-1	3-1
Water Cooled Condenser Connections, FIGURE 3-1.....	3-2
Cooling Tower.....	3-2
Space Diagram (Air-Cooled Machine), FIGURE 3-2A.....	3-3
Space Diagram (Water Cooled Machine), FIGURE 3-2B.....	3-4
Wiring and Electrical Connection FIGURE 3-3	3-5
Electrical Specifications, TABLE 3-2	3-5
Phase Check, Voltage and Current unbalance	3-6
Rotation Check	3-6
Air-Cooled Condenser Installation Instructions.....	3-7,3-8
Pounds of R-22 to Add Vs. Liquid Line Length, TABLE 3-3	3-8
Air-Cooled Condenser Data, TABLE 3-4.....	3-9
Condenser Dimensions, FIGURE 3-4.....	3-10
Condenser Field Piping (Cold Weather Valve Kit), FIGURE 3-5	3-11
Equivalent Feet Due To Friction, TABLE 3-5.....	3-12
Minimum Traps For Discharge Lines, FIGURE 3-6	3-12
Wiring For Bohn BNHS04A029 Condenser (3 phase motors), FIGURE 3-7.....	3-13
Ice Bin Thermostat Sensor.....	3-15
Typical Bin Sensor Mounting, FIGURE 3-9	3-15
Programming Electronic Bin Thermostat	3-16
Installation Review: A Checklist	3-17

TABLE OF CONTENTS

	Page No.
<u>4. HOW YOUR TUBE-ICE MACHINE WORKS</u>	
Principle of Operation.....	4-1
Freeze Period.....	4-2
Harvest Period.....	4-2
Piping Nomenclature.....	4-2
Water Cooled Piping Schematic, FIGURE 4-1.....	4-3
Air-Cooled Piping Schematic, FIGURE 4-2.....	4-4
<u>5. START-UP AND OPERATION</u>	
Refrigeration System Review.....	5-1
Refrigerant Charge.....	5-1
Start-up Procedure.....	5-3
Control Panel Switch Layout, FIGURE 5-1.....	5-3
Shut-down Procedure.....	5-4
Operating Tips.....	5-4
Adding Refrigerant.....	5-5
<u>6. ELECTRICAL CONTROLS & THEIR FUNCTIONS</u>	
Control Panel (Cover On), FIGURE 6-1.....	6-1
Control Panel (Cover Removed), FIGURE 6-2.....	6-2
Control Panel (Cover Removed), and Optional Power Monitor, FIGURE 6-2A.....	6-3
Control Panel Components (CE & Australian Approved), FIGURE 6-2B.....	6-4
Control Panel Components and Part Numbers, TABLE 6-1.....	6-5
Control Panel Part Descriptions, TABLE 6-2.....	6-6
Electrical Schematic All Voltages, 50-60 Hz. Across Line Start, FIGURE 6-3.....	6-7
3-Phase Power - Electrical Schematic All Voltages, 50-60 Hz, FIGURE 6-3A.....	6-8
Compressor Schematic Detail All Voltages, 50-60 Hz., FIGURE 6-4.....	6-9
<u>7. MAINTENANCE</u>	
Ice-Making Section.....	7-1
Cleaning Procedure.....	7-1
Sanitizing Procedure.....	7-2
Water Distributors.....	7-3
Number of Water Distributors Per Tube Size, TABLE 7-1.....	7-3
Average Hole Size In Tube-Ice [®] , TABLE 7-2.....	7-3
Water Tank.....	7-3
Freezer Cover.....	7-3
Water Cooled Condensers.....	7-4
Checking Operation.....	7-4
Draining.....	7-4
Chemical Cleaning.....	7-5
Mechanical Cleaning.....	7-5
Lubrication.....	7-6
Lubrication, Compressor.....	7-6
Compressor Recommended Lubricants, TABLE 7-3.....	7-6

TABLE OF CONTENTS

	Page No.
<u>7. MAINTENANCE (cont)</u>	
Cutter Gear Reducer Lubrication	7-7
Preventive Maintenance.....	7-8
For The Manager	7-9
Preventive Maintenance Form	7-10
<u>8. TROUBLESHOOTING</u>	
List Of Symptoms	8-1
Machine Won't Run	8-2, 8-3
Freeze-Up Due To Extended Freezing Period	8-4
Freeze-Up Due To Ice Failing To Discharge	8-5
Poor Ice Quality	8-6
Low Ice Capacity	8-7
Low Compressor Oil Level.....	8-8
High Head Pressure (Water Cooled).....	8-9
High Head Pressure (Air-Cooled).....	8-10
<u>9. SERVICE OPERATIONS</u>	
Adjustable Blowdown (For Clearer Ice)	9-1
Water pump / Blowdown Assembly, FIGURE 9-1.....	9-1
Automatic Blowdown (Harvest Cycle).....	9-1
Float Valve (Make-Up Water)	9-1
Float Switch	9-2
Hansen Float, FIGURE 9-2	9-2
Hand Expansion Valve	9-3
Freezer Pressure Switch.....	9-3
Freezer Pressure Switch (Allen-Bradley), FIGURE 9-3	9-3
Capillary Bypass.....	9-4
High/Low Pressure Switch	9-4
High/Low Pressure Switch, FIGURE 9-4.....	9-4
Head Pressure	9-5
Water Cooled Units	9-5
Air-Cooled Units	9-5
Water Regulating Valve, FIGURE 9-5A	9-5
Condenser Fan Switch, FIGURE 9-5B	9-5
Condenser Cleaning.....	9-5
Air-Cooled Condenser	9-5
Compressor Motor Protection, Electronic.....	9-6
High Potential Testing	9-7
Field Troubleshooting.....	9-7
Electronic Module and Compressor Terminal Board Connections, FIGURE 9-6	9-8
Oil Pressure Safety Control / Sentronic Oil Safety, FIGURE 9-7.....	9-9
Oil Pressure Sensor.....	9-9
Oil Pressure Module	9-10

TABLE OF CONTENTS

	Page No.
<u>9. SERVICE OPERATIONS (cont.)</u>	
Coresense Protection	9-10
Oil Separator, FIGURE 9-8	9-11
Compressor Crankcase Heater	9-11
Control Circuit Protection.....	9-11
Thawing Timer, FIGURE 9-9A	9-12
Thawing Timer	9-12
Pump Down	9-13
Removal Of Refrigerant From Machine	9-13
Refrigerant Leaks.....	9-14
Non-Condensable Gases	9-14
Compressor Motor Burnout	9-14
Solenoid Valves	9-15
Thawing Gas Solenoid Valve (“D” Valve), FIGURE 9-10A.....	9-15
Liquid Feed Solenoid Valve (“A1” & “A2” Valve), FIGURE 9-10B	9-15
Capacity Control Valve (Compressor Unloader)	9-16
Copeland Compressor Unloader Valve, FIGURE 9-11	9-16
Loaded Operation (Freeze Period).....	9-16
Unloaded Operation (During Thaw Only)	9-16
Circulating Water Pump Motor, FIGURE 9-12	9-17
Cutter Gear Reducer, FIGURE 9-13	9-17
Component Removal and Replacement Operations.....	9-18
Cutter Gear Reducer	9-18
Water Tank Removal	9-19
Cutter & Bearing Removal/Installation	9-19
Cutter Assembly, FIGURE 9-14.....	9-20
Cutter Parts (Cylinder Ice), FIGURE 9-15	9-20
Cutter Drive Parts, FIGURE 9-16.....	9-21
Crushed Ice Production, FIGURE 9-17	9-22
Defrost Pressure Switch - DPS (R404A Machines only).....	9-23
Pressure Relief Valve	9-23
Technical Service Bulletin (Water quality)	9-24
<u>10. OPTIONS AND ACCESSORIES</u>	
Power Monitor, FIGURE 10-1	10-1
Power Monitor, Parameters, TABLE 10-1	10-2
PLC, Programmable Logic Controller	10-4
<u>11. TABLES AND CHARTS</u>	
P18FXT Ratings (60 Hz.), TABLE 11-1	11-1
P18FXT Ratings (50 Hz.), TABLE 11-2	11-2
P18FXT Capacity Ratings, TABLE 11-3	11-3
Condenser Water Usage, TABLE 11-4.....	11-4
Make-up Water Usage (gpm), TABLE 11-5.....	11-4

TABLE OF CONTENTS

Page No.

11. TABLES AND CHARTS (cont.)

Normal Operating Vitals, TABLE 11-6..... 11-4
Recommended Spare Parts List 11-5
Temperature - Pressure Chart for Common Refrigerants, TABLE 11-7..... 11-6
Conversion Factors: English to Metric, TABLE 11-8 11-7
Constants, TABLE 11-9 11-7

12. INDEX

TABLE OF CONTENTS

BLANK

1. Introduction

VOGT ICE[®], LLC

A Brief History Of Our Company. Henry Vogt Machine Co. was founded as a small machine shop in Louisville, Kentucky in 1880. In 1938, Vogt built the first Tube-Ice[®] machine and revolutionized the ice-making industry. Our first “sized-ice” machine quickly replaced the old can-ice plants, which required much hard labor and large amounts of floor space for freezing, cutting, and crushing ice by hand.

Today, VOGT ICE[®], LLC carries on the tradition as one of the world’s leading producers of ice-making equipment.

Vogt Energy-Saving Tube-Ice Machines Are Cost Effective. Today, Vogt Tube-Ice[®] machines enjoy a well-earned reputation as the most energy efficient, dependable ice-making equipment in the world.

Using as little as one-half to one-third the energy required by competitors’ icemakers, Tube-Ice[®] machines produce the same amount of ice--in restaurants, sports arenas, packing plants, and wholesale operations around the globe--at great savings.

In addition, Tube-Ice[®] machines are renowned for their long life, giving many customers more than 35 years of dependable service. Ask someone who owns one.

Preview All the skill in engineering and fabrication that we have learned in over a century of experience is reflected in the 10TA model Tube-Ice[®] machines. Since Vogt introduced Tube-Ice[®] machines in 1938, the process of making Tube-Ice[®] ice has been widely recognized as the most economical means of production. The machine’s economic and reliable operations have been proven over and over again in a network of varied types of installations throughout the world.

Furnished with your machine is the “Certificate of Test”--the report of operating data that is a record of the unit’s satisfactory operation on our factory test floor. It is evidence of our desire to deliver to you “the finest ice-making unit ever made.”

This manual is designed to assist you in the installation, start-up, and maintenance of your unit. Your Tube-Ice[®] machine will give you a lifetime of service when you install it, maintain it, and service it properly.

Please read your manual carefully before attempting installation, operation, or servicing of this professionally designed piece of equipment.

If you have additional questions, please call your distributor. Also, feel free to phone the factory direct at **(502) 635-3000** or **1-800-853-8648**.

INTRODUCTION

Important Safety Notice. This information is intended for use by individuals possessing adequate backgrounds of electrical, refrigeration and mechanical experience. Any attempt to repair major equipment may result in personal injury and property damage. The manufacturer or seller cannot be responsible for the interpretation of this information, nor can it assume any liability in connection with its use.

Special Precautions To Be Observed When Charging Refrigeration Systems. Only technically qualified persons, experienced and knowledgeable in the handling of refrigerant and operation of refrigeration systems, should perform the operations described in this manual. All local, federal, and EPA regulations must be strictly adhered to when handling refrigerants.

If a refrigeration system is being charged from refrigerant cylinders, disconnect each cylinder when empty or when the system is fully charged. A gage should be installed in the charging line to indicate refrigerant cylinder pressure. The cylinder may be considered empty of liquid R-22/R404A refrigerant when the gauge pressure is 25 pounds or less, and there is no frost on the cylinder. Close the refrigerant charging valve and cylinder valve before disconnecting the cylinder. Loosen the union in the refrigerant charging line--carefully to avoid unnecessary and illegal release of refrigerant into the atmosphere.

! CAUTION !

Immediately close system charging valve at commencement of defrost or thawing cycle if refrigerant cylinder is connected. Never leave a refrigerant cylinder connected to system except during charging operation. Failure to observe either of these precautions can result in transferring refrigerant from the system to the refrigerant cylinder, over-filling it, and possibly causing the cylinder to rupture because of pressure from expansion of the liquid refrigerant.
--

! CAUTION !

Always store cylinders containing refrigerant in a cool place. They should never be exposed to temperatures higher than 125°F and should be stored in a manner to prevent abnormal mechanical shocks.

Also, transferring refrigerant from a refrigeration system into a cylinder can be very dangerous and is not recommended.

! CAUTION !

It is not recommended that refrigerant be transferred from a refrigeration system directly into a cylinder. If such a transfer is made, the refrigerant cylinder must be an approved, CLEAN cylinder--free of any contaminants or foreign materials--and must be connected to an approved recovery mechanism with a safety shutoff sensor to assure contents do not exceed net weight specified by cylinder manufacturer or any applicable code requirements.
--

! CAUTION !

Safety Symbols & What They Mean. Prior to installation or operation of the Tube-Ice® machine, please read this manual. Are you familiar with the installation, start-up, and operation of a Tube-Ice® machine? Before you operate, adjust or service this machine, you should read this manual, understand the operation of this machine, and be aware of possible dangers.

**These Safety Symbols will alert you
when special care is needed.**

Please heed.

! DANGER !
Indicates an immediate hazard and that special precautions are necessary to avoid severe personal injury or death.
! DANGER !

! WARNING !
Indicates a strong possibility of a hazard and that an unsafe practice could result in severe personal injury.
! WARNING !

! CAUTION !
Means hazards or unsafe practices could result in personal injury or product or property damage.
! CAUTION !

INTRODUCTION

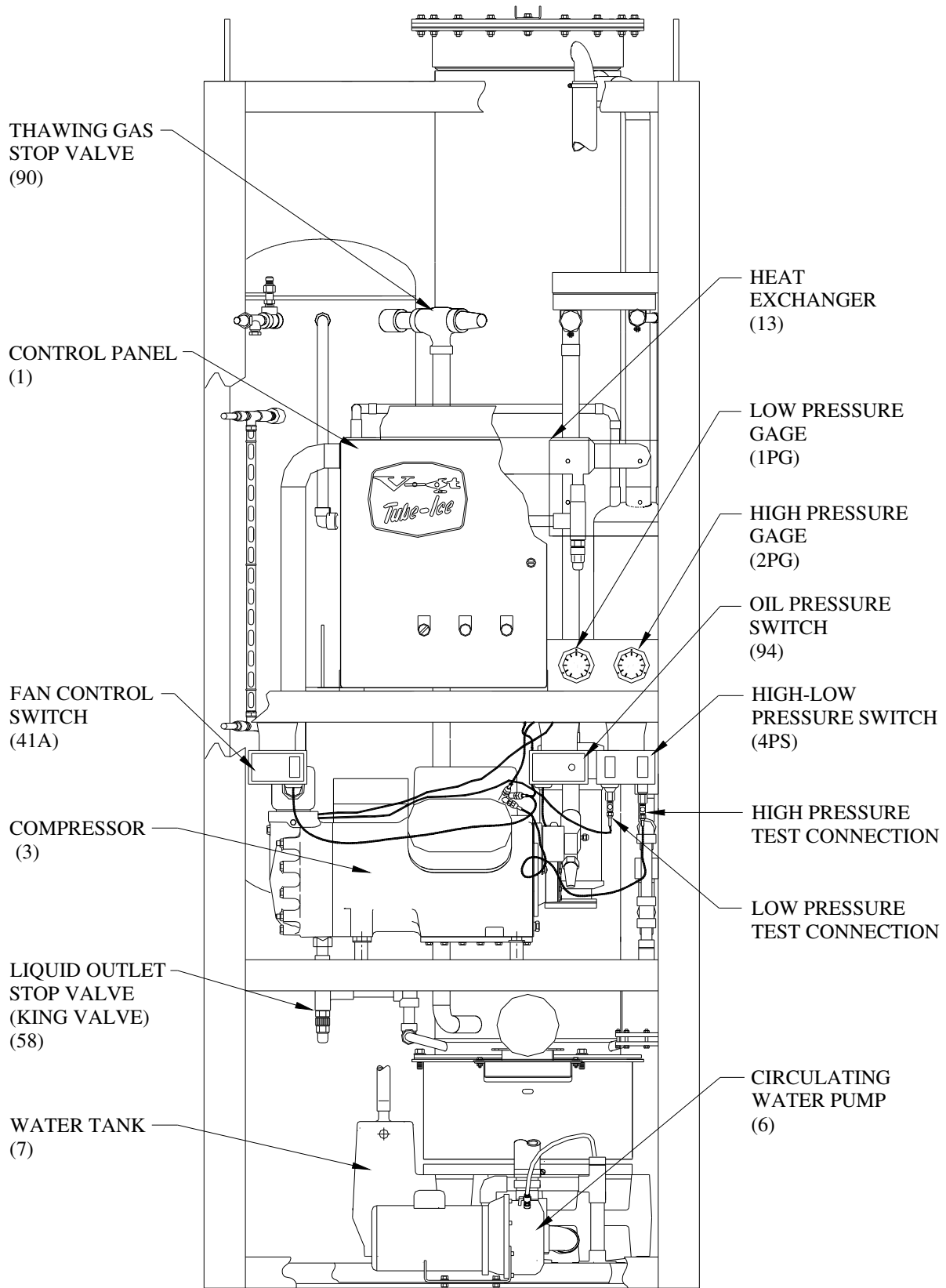

FIGURE 1-1
Assembly (Air-Cooled)
Front View

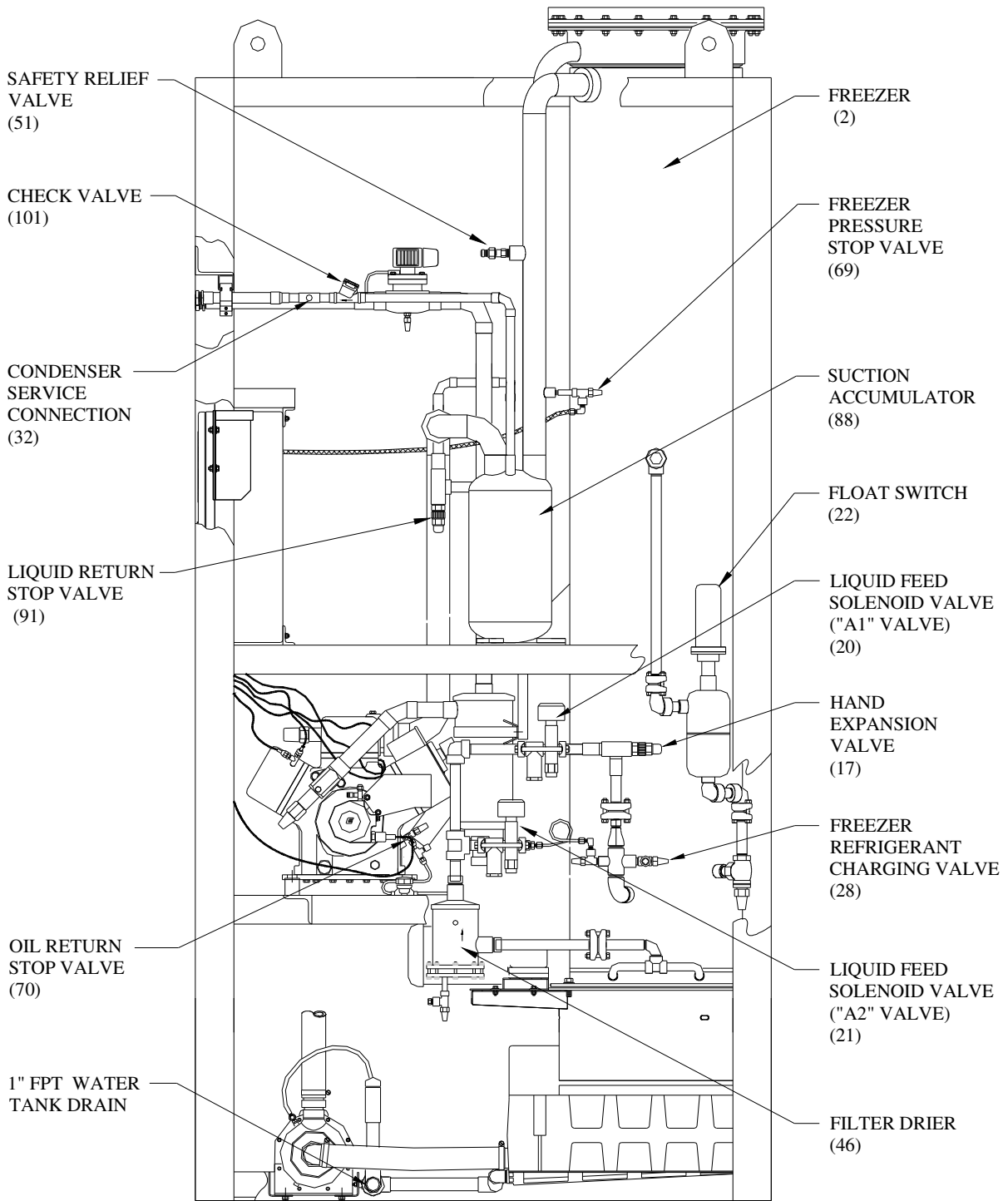

FIGURE 1-2
Assembly (Air-Cooled)
Right Side View

INTRODUCTION

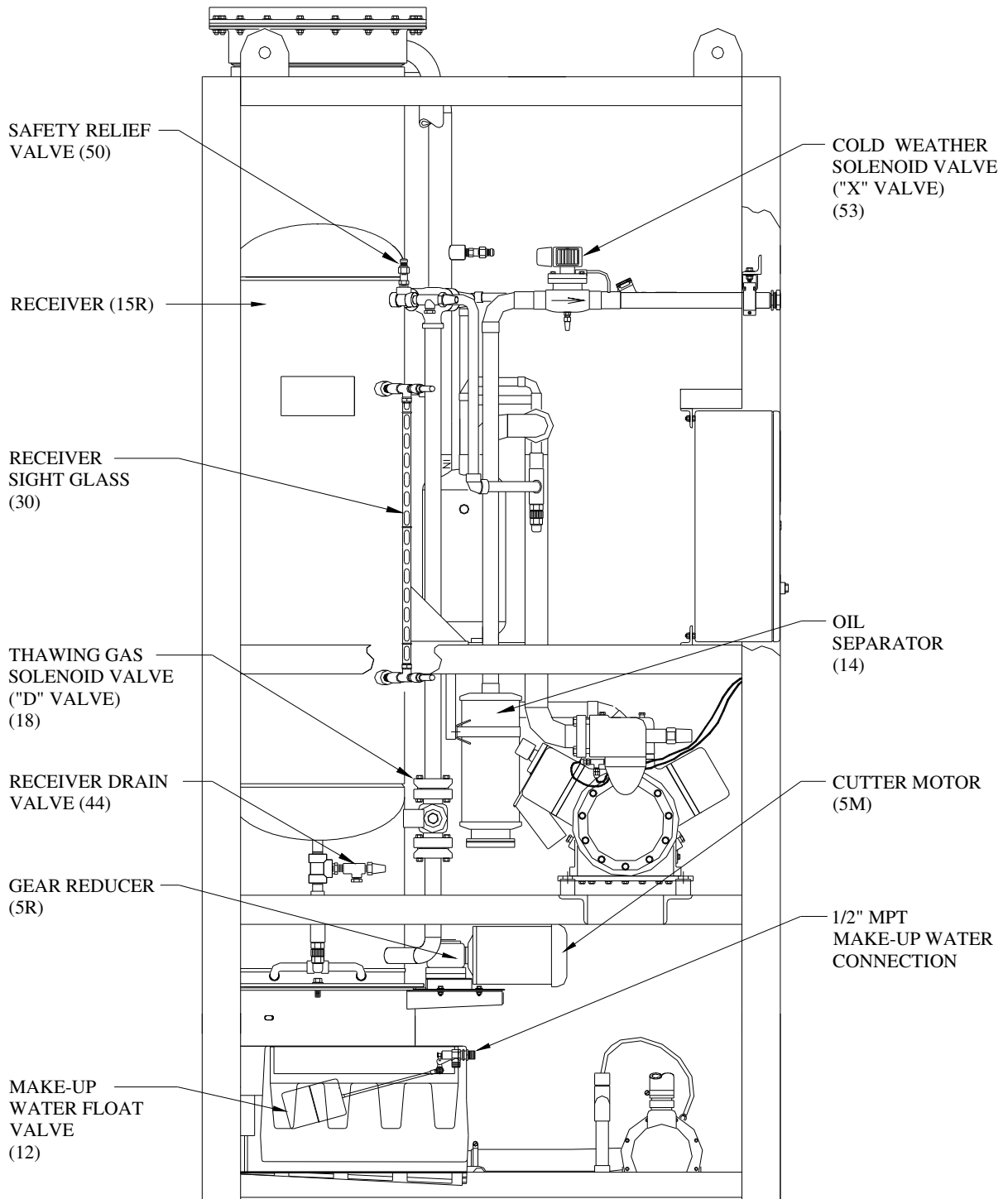

FIGURE 1-3
Assembly (Air-Cooled)
Left Side View

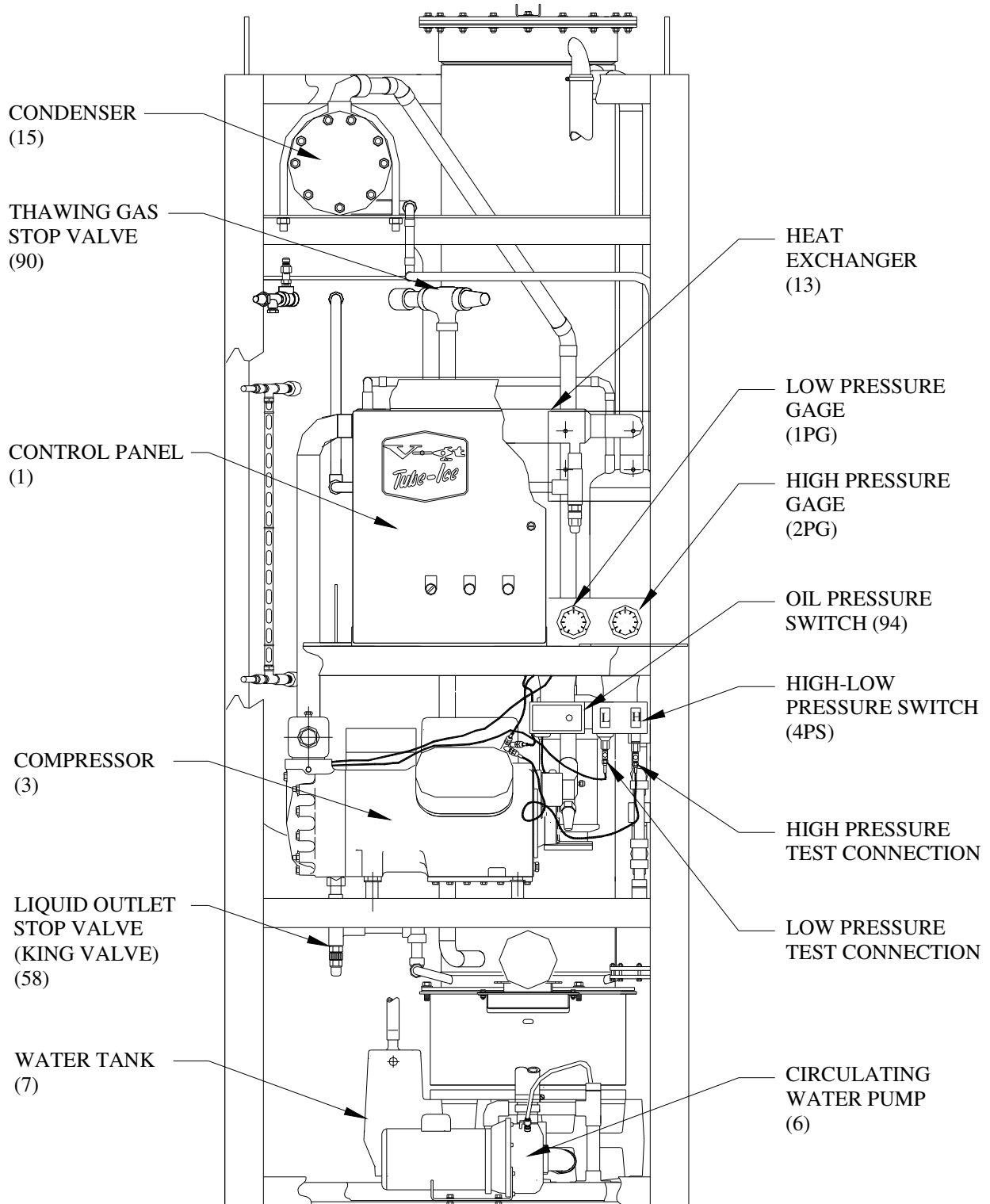

FIGURE 1-4
Assembly (Water Cooled)
Front View

INTRODUCTION

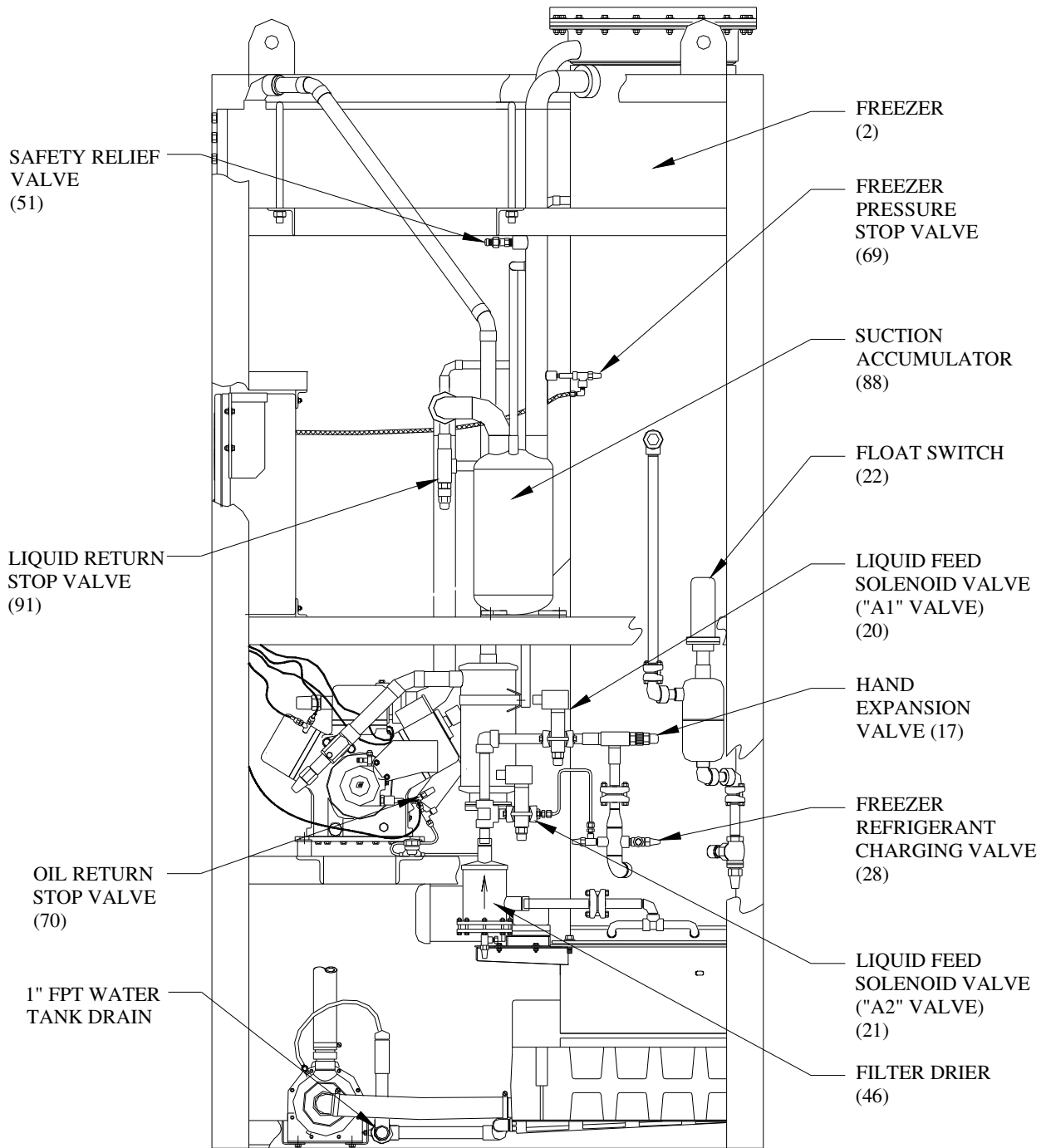

FIGURE 1-5
Assembly (Water Cooled)
Right Side View

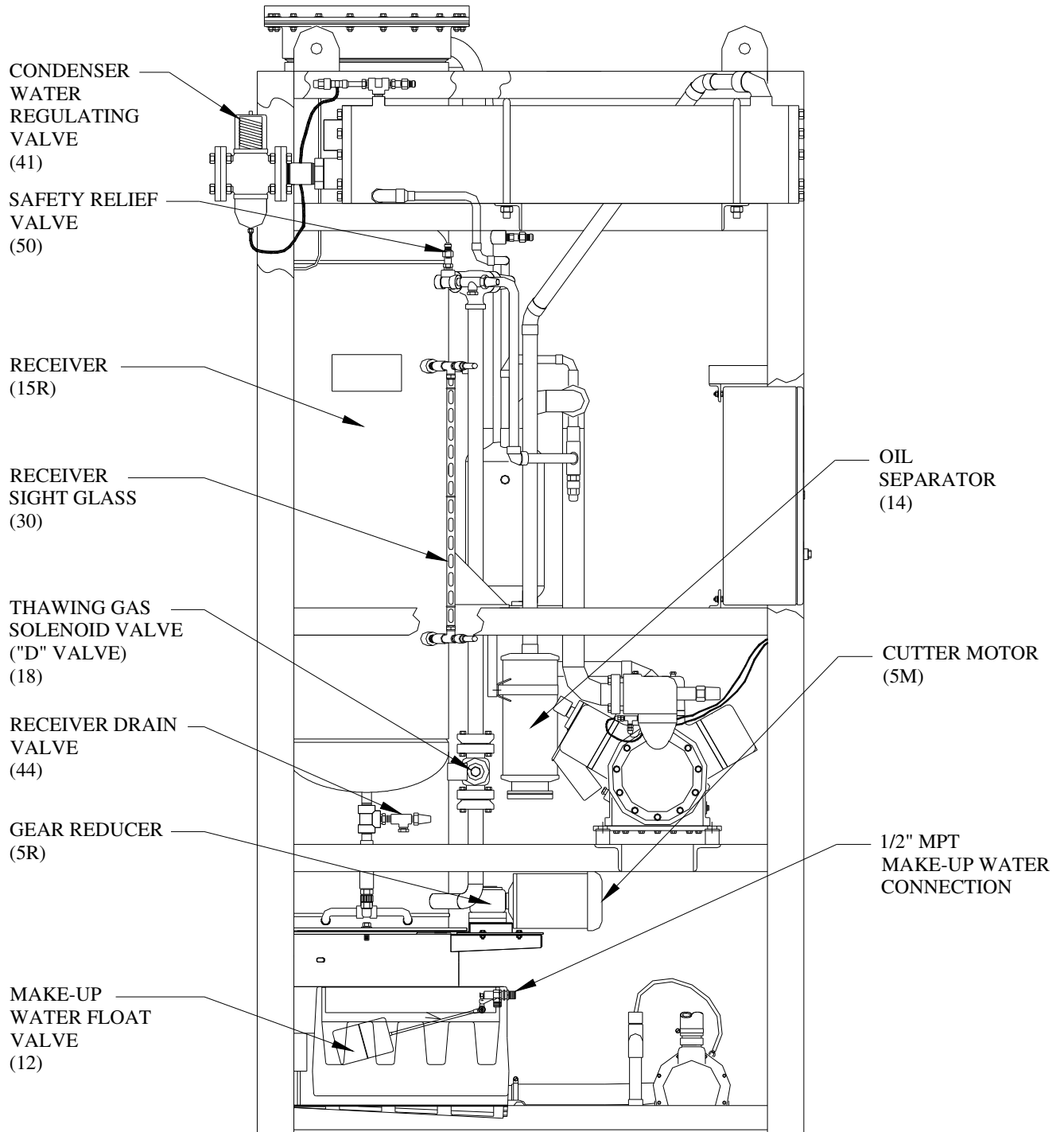

FIGURE 1-6
Assembly (Water Cooled)
Left Side View

INTRODUCTION

BLANK

2. Receipt Of Your Tube-Ice Machine

! WARNING !
Only service personnel experienced in refrigeration and qualified to work with high voltage electrical equipment should be allowed to install or work on this Tube-Ice[®] machine.
! WARNING !

Inspection As soon as you receive your machine, inspect it for any damage. If damage is suspected, note it on the shipper's papers (i.e., the trucker's Bill of Lading). Immediately make a separate written request for inspection by the freight line's agent. Any repair work or alteration to the machine without the permission of Vogt Ice, LLC can void the machine's warranty.

The machine was shipped with a full charge of refrigerant stored in the receiver. Visually check all lines for mechanical damage. If a leak is suspected, check all joints with a Halogen Leak Detector. All leaks should be reported to the Vogt Ice, LLC to obtain authorization for repair.

! CAUTION !
The approximate weight of the machine is 4900 pounds. Always use equipment with adequate load carrying capacity.
! CAUTION !

The machine frame has lifting lugs at each corner in the top for eyebolts and hooks to be used for lifting purposes if desired. Lifting lugs should be used whenever possible.

! CAUTION !
The Tube-Ice[®] machine is top heavy. Secure to avoid tipping.
! CAUTION !

If a forklift is used, make sure its capacity is sufficient. The forks must be wide enough apart to prevent tipping sideways and must extend beyond the extremities of the frame base structure. The machine needs to be bound in place to prevent tipping.

Safety Valves Two safety pressure relief valves are an integral part of the packaged Tube-Ice[®] machine. One is located in the low-side of the system on the freezer, and one is in the high side of the system on the receiver. Vent each of the pressure relief valves to the atmosphere in such a manner as to comply with local and national codes.

Machine Room The machine must be located inside a suitable building and must not be subjected to ambient temperatures below 50°F (10°C) or above 110°F (43.3°C). Heat from other sources (sunlight, furnaces, condenser, etc.) and unusual air current may affect the operation of the machine and should be avoided. The electrical components of the Tube-Ice[®] machine are rated NEMA 1. Therefore, the machine should not be located in a hazardous area or sprayed with water. The machine should be installed on a drainable condensate drip pan or in an area where water will not stand but will readily drain away from the machine. See Space Diagram for clearances and utility connections, FIGURES 3-2A and 3-2B.

RECEIPT OF YOUR TUBE-ICE MACHINE

Storage (prior to installation or start-up). The machine must not be stored or installed in an area that may reach temperatures 115°F (46.1°C) or above.

! CAUTION !
This equipment contains HCFC-22 or HFC-404a refrigerant under pressure. Do not store in an area exposed to temperatures above 115°F (46°C) or in direct sun at temperatures above 105°F (40°C).
! CAUTION !

The machine nameplate is located on the front of the control panel. The model number and machine description are located in the top left hand corner. The following figure can be used to verify that the correct model has been received.

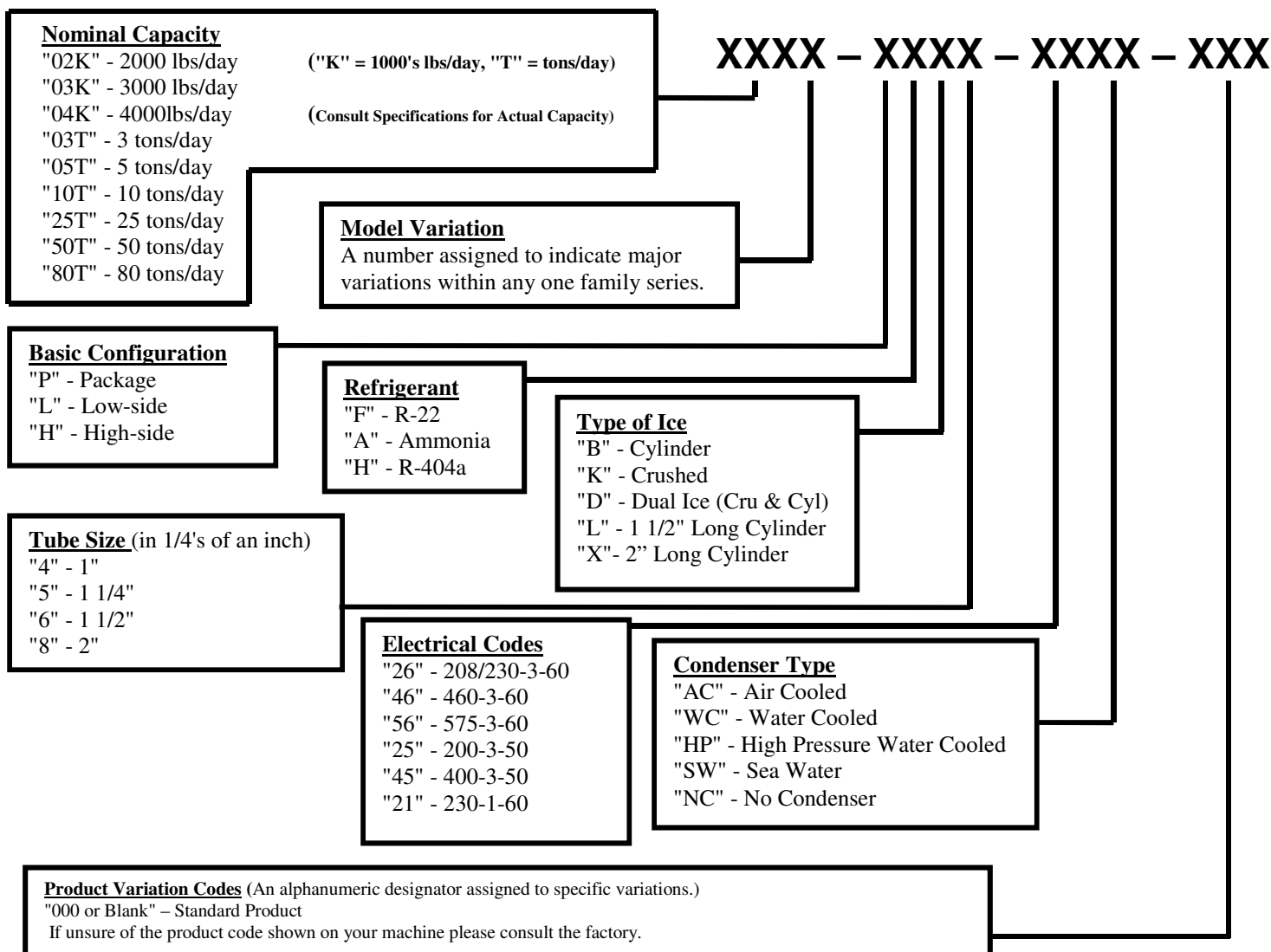

**Figure 2-1
Vogt Model Nomenclature**

3. Installing Your Tube-Ice® Machine

! WARNING !
Only service personnel experienced and certified in refrigeration and qualified to work with high voltage electrical equipment should be allowed to install or work on this Tube-Ice® machine.
! WARNING !

Important Notice.

To activate the machine warranty, the Product Registration Form **MUST** be completed and returned to the factory promptly after the official start-up. Product Registration Form is located in the Owners Packet or can be found online at www.vogtice.com/registration.htm.

Piping and Drain Connections

Figure 3-2A (Air Cooled) and 3-2B (Water Cooled) show locations and sizes for all connections.

! CAUTION !
External shut-off valves must be provided in the water inlet lines. The minimum inlet water pressure for satisfactory operation of the machine is 30 psig. The maximum allowable pressure is 100 psig.
! CAUTION !

Make-up Water In	Water Tank Drain*	Condenser Water In	Condenser Water Out*
1/2" MPT	1" FPT	2" FPT	2 1/2" FPT

**TABLE 3-1
Water Supply and Drain Sizes**

- * The condenser water outlet and water tank drain connections must be extended to an open drain or sump, arranged for visible discharge. **Do not trap the water tank drain line**, as this will interfere with the operation of the automatic blowdown system.

! CAUTION !
These lines must NOT be connected into a pressure tight common header due to the possibility that warm condenser water may back up into the water tank. The condenser water outlet MUST be piped separately to the drain.
! CAUTION !

Note: Due to variations in water quality by geographic location, water filtering or treatment may be required to reduce maintenance and inhibit hardness buildup on machine components (tubes, valves).

INSTALLING YOUR TUBE-ICE® MACHINE

Water-Cooled Connections

Note: Water regulator valve is not installed on condenser when shipped from the factory. Installed water regulator valve on condenser water inlet connection (bottom connection on condenser). Connect the condenser water out line to the top connection on the condenser.

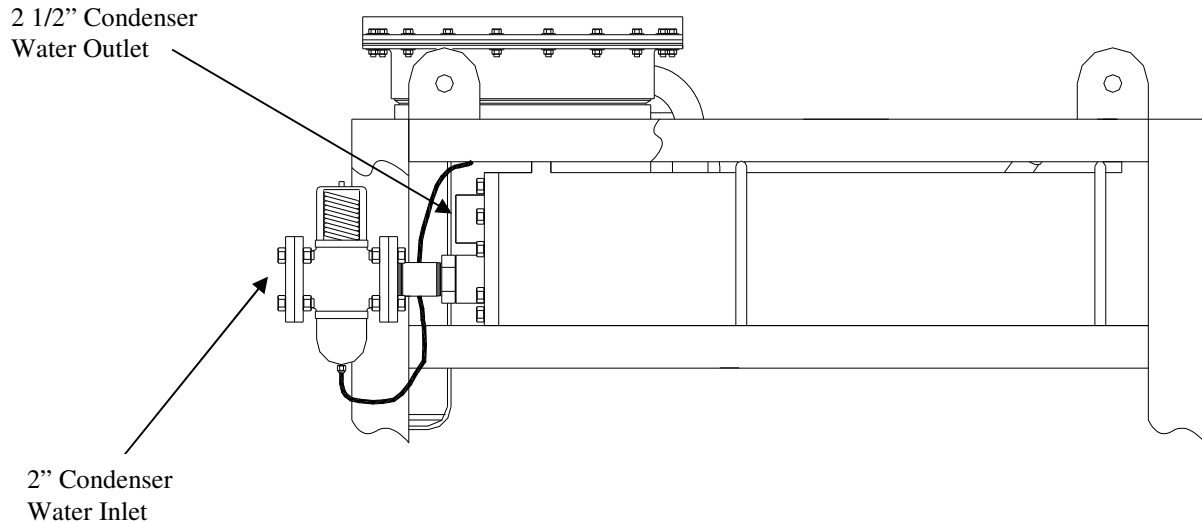

FIGURE 3-1
Water Cooled Condenser Connections

Cooling Tower

For water cooled machines only. When selecting a cooling tower, careful attention must be given to operating wet bulb conditions. It is advisable to check with your local cooling tower distributor for their recommendations based on actual operating conditions in your area. An average wet-bulb of 78°F is typical in the U.S. but many localities have design wet-bulbs as low as 72°F or as high as 82°F.

The cooling tower water pump must be capable of delivering the required volume of water through the condenser. Due to cooling tower location and pressure drop through water lines and water regulating valves, the pump must be sized for each installation. Refer to TABLE 11-4 for condenser water requirements. The water piping for the cooling tower and the installation of the pump must be in accordance with the manufacturer's instructions.

Proper water treatment for the prevention of mineral and foreign matter accumulation in the condenser or cooling tower is recommended. A water analysis should be obtained to determine the proper chemicals to use.

INSTALLING YOUR TUBE-ICE® MACHINE

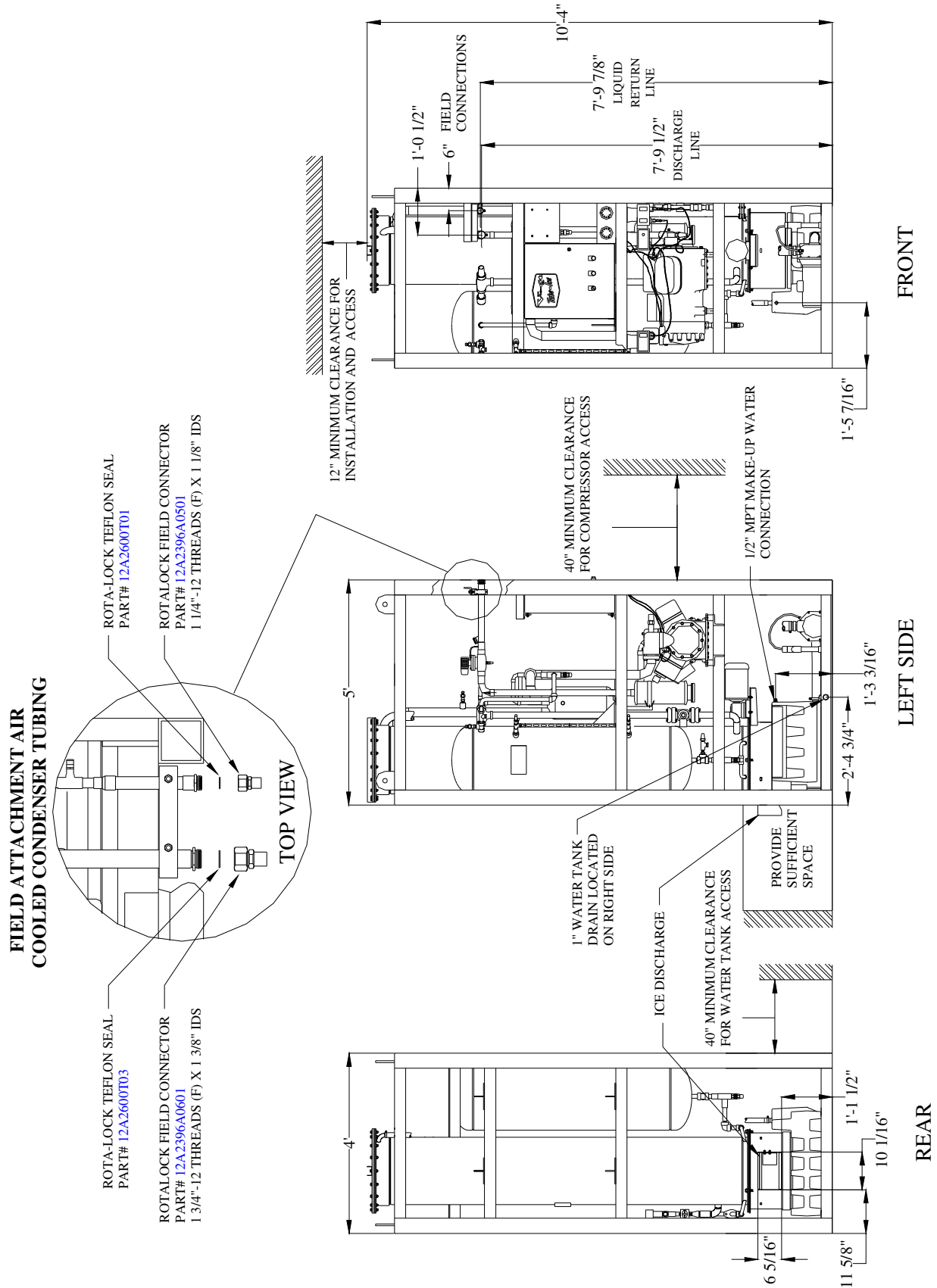

FIGURE 3-2A
Connections and Space Diagram (Air Cooled Machine)

INSTALLING YOUR TUBE-ICE® MACHINE

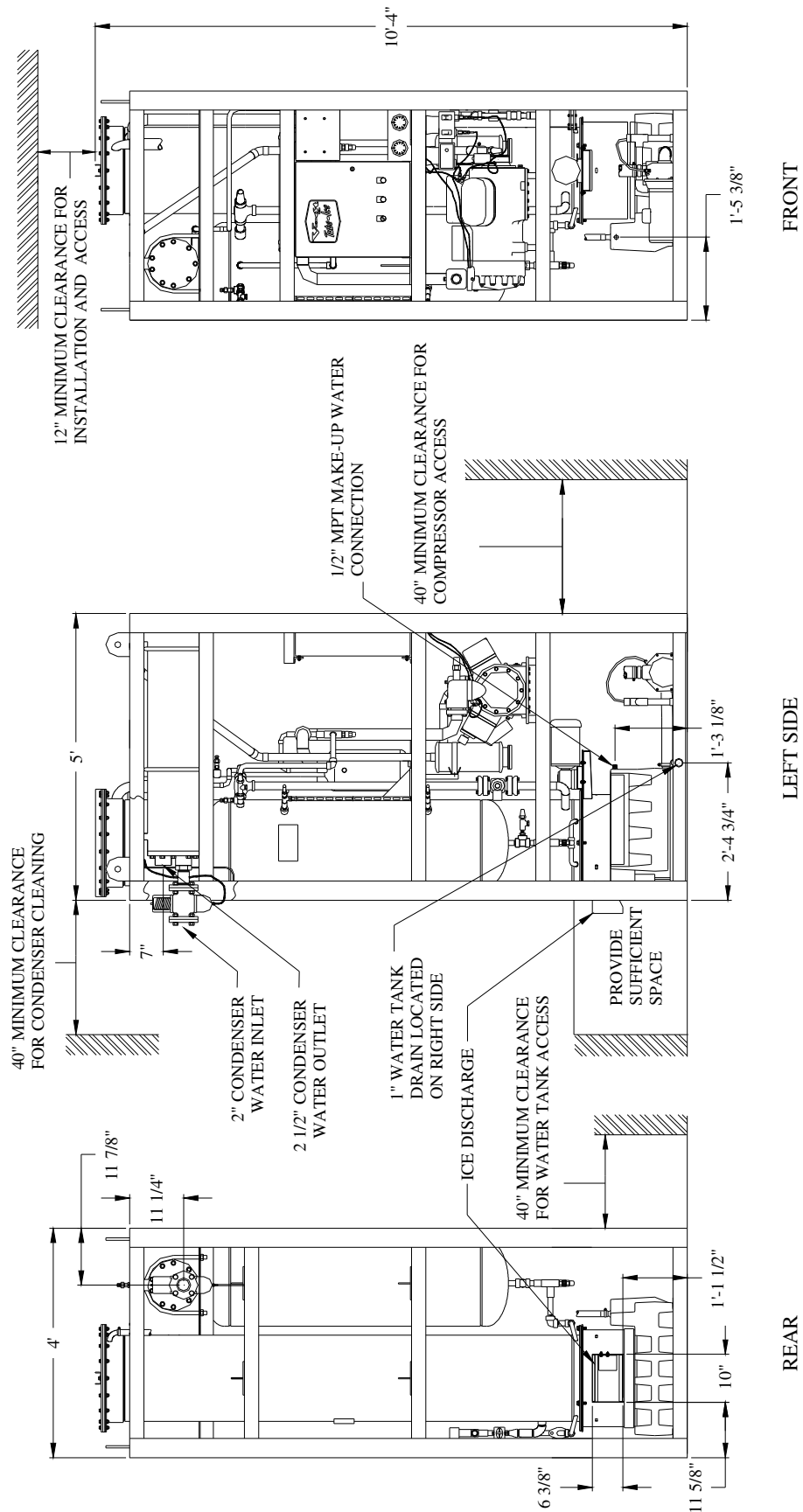

FIGURE 3-2B
Connections and Space Diagram (Water Cooled Machine)

Wiring and Electrical Connection

! WARNING !

Only service personnel experienced in refrigeration and qualified to work with high voltage electrical equipment should be allowed to install or work on the Tube-Ice® machine.

! WARNING !

Refer to TABLE 3-2 below to properly size wiring connections. A fused disconnect must be provided near the Tube-Ice® machine. Connect 3 phase power to terminals L1, L2, L3 for operation of the Tube-Ice® machine and its controls. Rotation checking of cutter motor and water pump is required (see following section). Also, if one leg of the 3 phase power is higher or lower (“Wild”), then it should be connected to terminal #L2. Connect the “Ground” wire to the “Ground” lug provided.

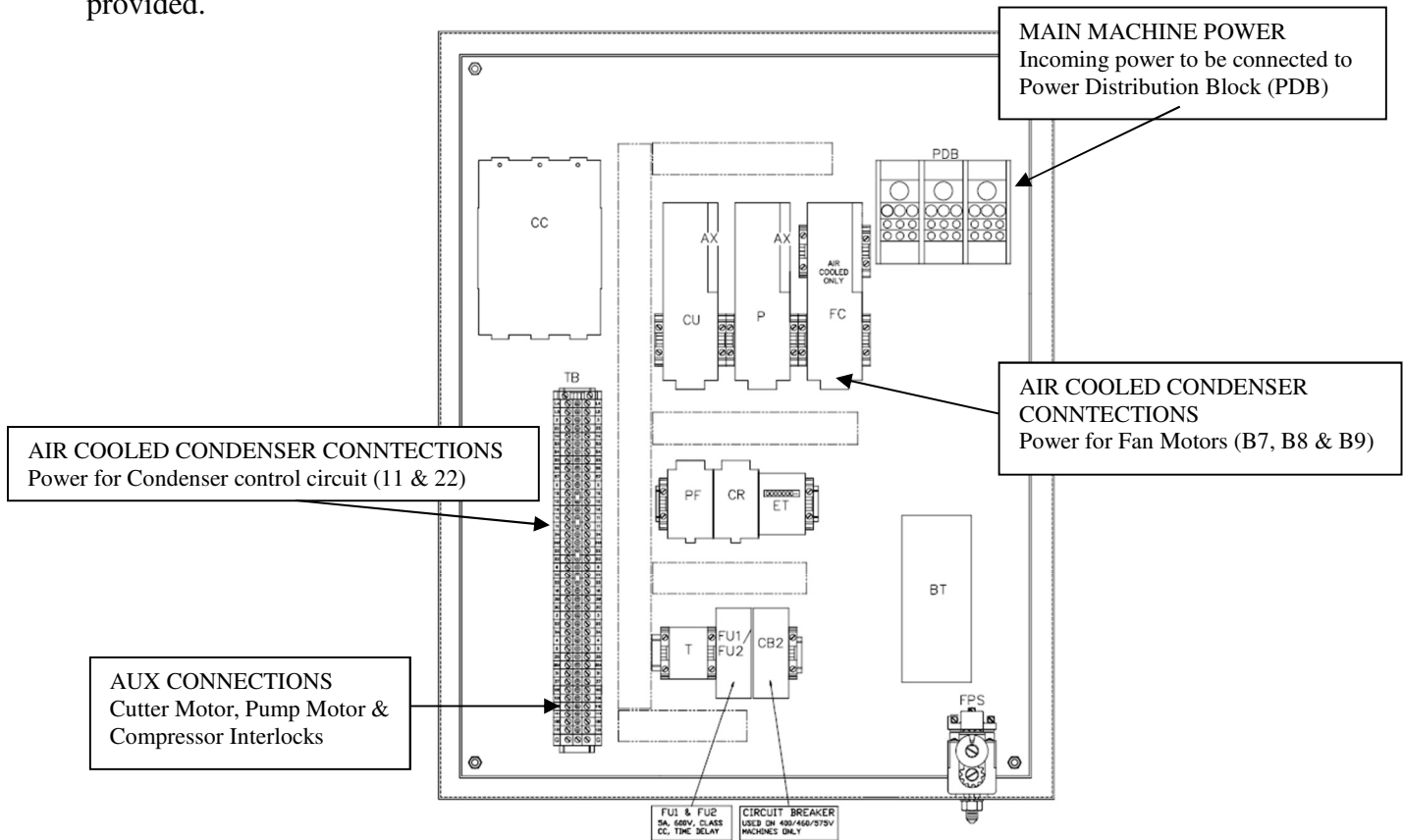

**FIGURE 3-3
Control Panel Power Connections**

Standard Voltages	Water Cooled			Air Cooled		
	F.L.A.	Min. Ampacity	Max. Fuse	F.L.A.	Min. Ampacity	Max. Fuse
208/230, 3ph, 60 Hz	112.3	138.6	245	140.3	166.6	275
460, 3ph, 60 Hz	56.2	69.3	125	70.2	83.3	140
220, 3ph, 50 Hz	134.1	165.4	295	162.1	193.4	320
400, 3ph, 50 Hz	67.3	82.9	150	81.3	96.9	160

**TABLE 3-2
Electrical Specifications**

INSTALLING YOUR TUBE-ICE® MACHINE

Phase Check

! CAUTION !
DO NOT attempt to start machine without priming pump and insuring proper rotation of both cutter and pump. Refer to FIGURE 3-1 & 3-2 (space diagram) for connection locations.
! CAUTION !

Cutter and pump motor rotation are factory synchronized but **must** be checked at installation. For ice production, the cutter disc, as viewed at the ice discharge opening should turn from left to right (crushed rotation should be from right to left). The pump rotation should match the marking on the pump housing. The pump will need to be primed by starting the machine in the clean mode and allowing it to run for several minutes. To change direction of rotation for both, cutter and pump, disconnect power and reverse L1 and L3 (incoming power wires) at the compressor motor contactor.

Voltage Unbalance Voltage unbalance can cause motors to overheat and fail.

The maximum voltage unbalance between any two legs should be no greater than 2%.

Example: Supply Voltage = 230-3-60

Voltage Readings:	AB = 220 Volts	Average = (220 + 225 + 227)/3 = 224 Volts
	BC = 225 Volts	
	AC = 227 Volts	

(AB) 224-220 = 4 Volts (Highest Deviation)

(BC) 225-224 = 1 Volts

(AC) 227-224 = 3 Volts

% Voltage Unbalance = 100 x (4/224) = 1.78% "Acceptable"

Important: If the supply voltage phase unbalance is more the 2%, contact your local electric utility company.

Current Unbalance Voltage unbalance will cause a current unbalance, but a current unbalance does not necessarily mean that a voltage unbalance exists. A loose terminal connection or a buildup of dirt or carbon on one set of contacts would cause a higher resistance on that leg than on the other two legs. Current follows the path of least resistance, therefore if terminal connection L1 is loose or dirty, L2 and/or L3 will have higher current. Higher current causes more heat to be generated in the motor windings.

The maximum acceptable current unbalance is 10%.

Example:

Current Readings:	L1 = 96 Amps	Average = (96 + 91 + 98)/3 = 95Amps
	L2 = 91 Amps	
	L3 = 98 Amps	

(L1) 96-95 = 1 Amps

(L2) 95-91 = 4 Amps (Highest Deviation)

(L3) 98-95 = 3 Amps

% Current Unbalance = 100 x (4/95) = 4.2% "Acceptable"

Air-Cooled Condenser Installation Instructions

! WARNING !

**These installation guidelines must be followed to obtain
reliable operation from air cooled ice machines.
IF THESE GUIDELINES ARE NOT FOLLOWED THE
COMPRESSOR WARRANTY WILL NOT BE HONORED.**

! WARNING !

1. Use only Vogt approved condensers. Any exceptions to this policy must be obtained in writing from Vogt prior to installation and operation of the ice machine.
2. Outdoor condensers **must** be installed with vertical air flow. Indoor condensers used for heat recovery may be installed with either horizontal or vertical air flow.
NOTE: Condenser must be ordered for horizontal air flow.
3. The condenser **must** be mounted above the ice machine.
4. Horizontal runs in the liquid return line should slope 1/4" per foot with liquid refrigerant draining freely in the direction of normal operating flow (back to the ice machine) with no traps in the liquid line.
5. Horizontal runs in the discharge line should slope 1/4" per foot in the normal direction of flow (away from the ice machine).
6. Traps must be installed in discharge lines at the base of all vertical risers. There should be no intentional traps in liquid lines. Trap volume should be kept to a minimum. Long vertical rises should have traps every 20 feet. Typical details are shown in FIGURE 3-6.
7. Flooding head pressure controls such as Alco Headmaster are not to be used since they cause excessive subcooling of the returned liquid refrigerant and interfere with reliable ice harvest.
8. The discharge and liquid lines must be insulated with 1/2" thick Armaflex insulation or equal.
9. Use only ACR grade copper pipe, Type L. Recommended line sizes are shown in TABLE 3-3.
10. For field attachment instructions, see FIGURE 3-4.
11. Distance between ice machine and condenser must not exceed 150 equivalent feet. Refer to Condenser Equivalent Line Size worksheet (see TABLE 3-5).
12. Condensers must be provided with a cold weather valve kit per FIGURE 3-5. These valves allow one-half of the condenser to be disabled in cold weather. Running the ice machine with one-half of the condenser in cold weather makes it easier to maintain minimum necessary condensing pressure particularly in windy conditions.
13. Condensers with multiple fans must be provided with a thermostat to turn off unneeded fans in cold weather. Turning off unneeded fans reduces on-off cycling of the fan(s) and allows for a steadier condensing pressure and more consistent warm gas for ice harvesting.

INSTALLING YOUR TUBE-ICE® MACHINE

14. When extreme cold conditions are expected or encountered (temperatures below 0°F and wind greater than 15 MPH), it may be necessary to install a protective enclosure around the condenser. Apparatuses such as louvers may also be used for varying conditions. Contact the factory for suggestions.
15. After installation, the field installed lines are to be evacuated to a vacuum of 500 microns or less and held for at least one hour. After the vacuum pump is removed, vacuum should hold at 500 microns or less for at least 5 minutes.
16. The machine is shipped with a full operating charge of refrigerant sufficient to fill the condenser and connecting lines. If the condenser piping is longer than 50 feet (one way), additional R-22 or R-404A may need to be added to retain enough refrigerant in the receiver for thawing purposes (see table. Refer to the operating level mark on the receiver and charge accordingly. Each 1” of liquid level in the receiver equals approximately 5.5 pounds of R-22 or R-404a.

Liquid Line Size	75 ft.	100 ft.	125 ft.	150 ft.
1/2”	none	None	None	2
5/8”	none	2	4	6
7/8”	none	4	8	12
1-1/8”	none	6	12	18

TABLE 3-3
Pounds of R-22 /R404A to Add vs. Liquid Line Length

17. All piping must be done in accordance with applicable local and national codes. Such codes may include “The Safety Code For Mechanical Refrigeration” (ANSI B9.1) and “The Code For Refrigerant Piping” (ANSI B31.5).
18. The following installation guidelines are strongly suggested. While they do not affect the machine warranty, they may be required for safe operation and to comply with all applicable electrical and mechanical codes:
 - a. Local electrical code must be checked for wiring method.
 - b. The installer must provide a disconnect switch(s) adjacent to the condenser.
 - c. Electrical connections between the condenser and the Tube-Ice® machine require minimum 10 ga. wire for 200/230V motors / 14 ga. wire for 400/460V motors. For control wiring, a minimum of 14 ga. wire should be used.
 - d. All electrical fittings and components exposed to the weather must be suitable for outdoor installation.

The design total heat rejection for each Tube-Ice® machine, the recommended air-cooled condenser, and condenser physical and electrical data are shown on the next page. Specified energy efficiency ratings of the ice machines are based on use of the recommended condenser and approved piping practices.

Recommended condensers provide the indicated total heat rejection at 90°F ambient, 100°F condensing. Vogt Ice, LLC is not responsible for head pressure problems if other than the recommended condensers are used. For continuous operation at ambient temperature above 105°F, consult the factory about using a larger condenser.

INSTALLING YOUR TUBE-ICE® MACHINE

Ice Machine Model	10TA	
	60	50
Electrical Frequency, Hz.	60	50
Recommended Condenser	BNHS04A029	
Total Heat Rejection (BTU/hr)	427,500	393,300
Fans:		
Number	4	4
HP, Each	1 1/2	1 1/2
Total CFM	38,600	38,600
Full Load Amps (FLA):		
3 ph., 208/230V, 60 hz.	28.0	--
3 ph., 460V, 60 hz.	14.0	--
3 ph., 200V, 50 hz.	--	28.0
3 ph., 380V, 50 hz.	--	14.0
Weight, lbs.:		
Net	1210	
Shipping	1520	
Operating (Maximum flooded) R-404a	1265	
Condenser Dimensions, inches (See Fig. 3-7)		
A (Width)	45.46"	
B (Length)	233.16"	
C (Height)	49.15"	
D (Leg centerline)	38"	
E (Leg centerline)	106.15(3)"	
F (Clearance below)	20.5"	
Recommended Line Sizes, OD		
Liquid		
All lengths and orientations	1 3/8"	
Discharge Gas		
Vertical Up, all lengths	1 5/8"	
Horiz. or Down, < 75 ft.	1 5/8"	
Horiz. or Down > 75 ft.	2 1/8"	
Connections (Condenser):		
Liquid (ODF)	1 3/8"	
Discharge Gas (ODF)	2 1/8"	
Connections (Ice Machine):		
Liquid (ODF)	1 1/8"	
Discharge Gas (ODF)	1 3/8"	

TABLE 3-4
Air-Cooled Condenser Data

INSTALLING YOUR TUBE-ICE® MACHINE

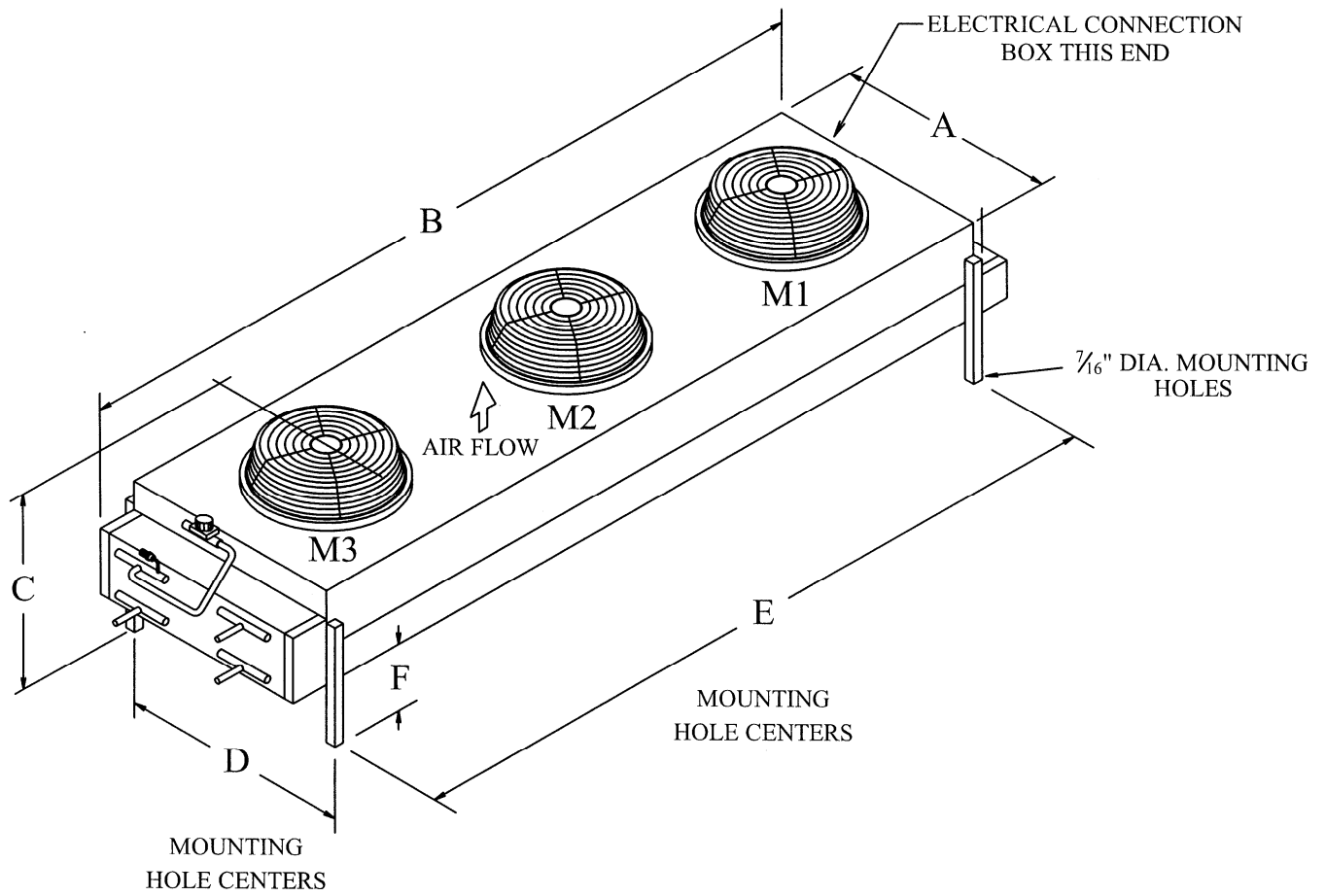
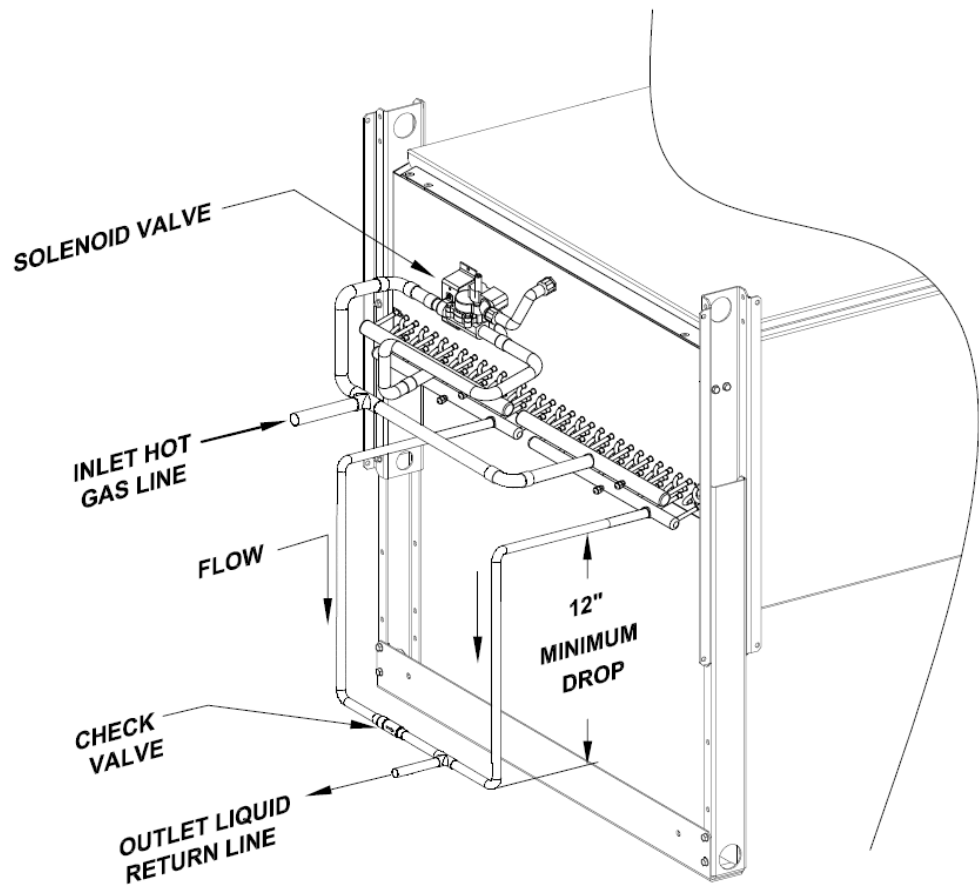
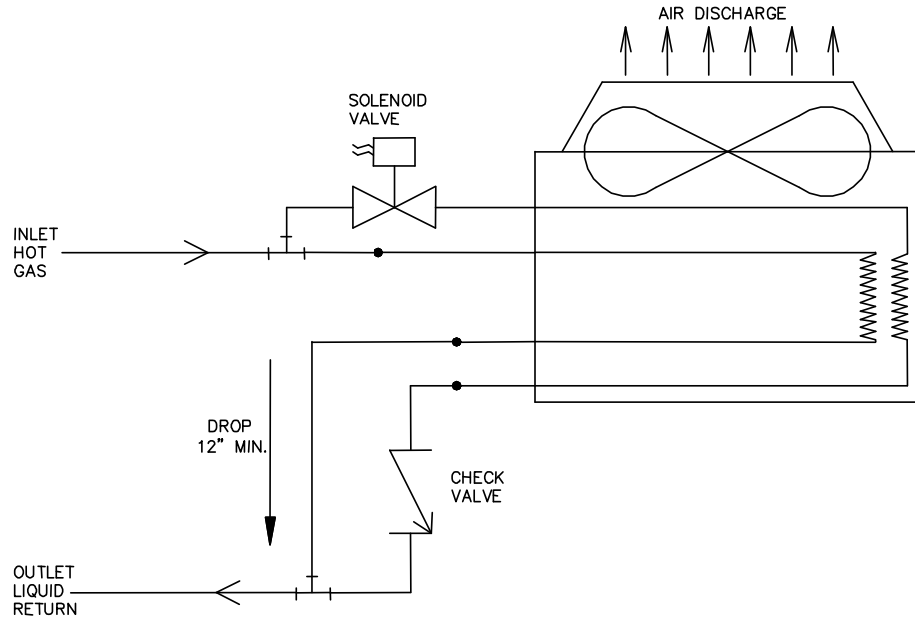

**FIGURE 3-4
Condenser Dimensions**

Machine	Bohn Part #	Vogt Part #	Coil Split
P18XT	BNHS04A029	12A2115B11	50/50

Note: Condensers listed above are 200/208/230V, 50/60hz. 400/460V, 50/60hz available

INSTALLING YOUR TUBE-ICE® MACHINE



Note: Condenser return lines supplied by customer. (check valve supplied by Vogt)

FIGURE 3-5
Condenser Field Piping (Cold Weather Valve Kit)

INSTALLING YOUR TUBE-ICE® MACHINE

CONDENSER EQUIVALENT LINE SIZE WORKSHEET

Discharge Gas Line O.D. _____

Fitting Type	Number Used	Factor	Total
Globe Valve (open)			
Angle Valve (open)			
90° Elbow			
45° Elbow			
Tee			

Feet of Straight Copper Used	
Total Fitting Factor	
Total Equivalent Feet	

Copper Tubing Type "L"	1 1/8" O.D.	1 3/8" O.D.	1 5/8" O.D.	2 1/8" O.D.
Globe valve (open)	28	36	42	57
Angle valve (open)	15	18	21	28
90° Elbow	3	4	4	5
45° Elbow	1.5	2	2	2.5
Tee (90° turn through)	6	8	9	12
Tee (straight through)	2	2.5	2.8	3.5

TABLE 3-5
Equivalent Feet Due To Friction

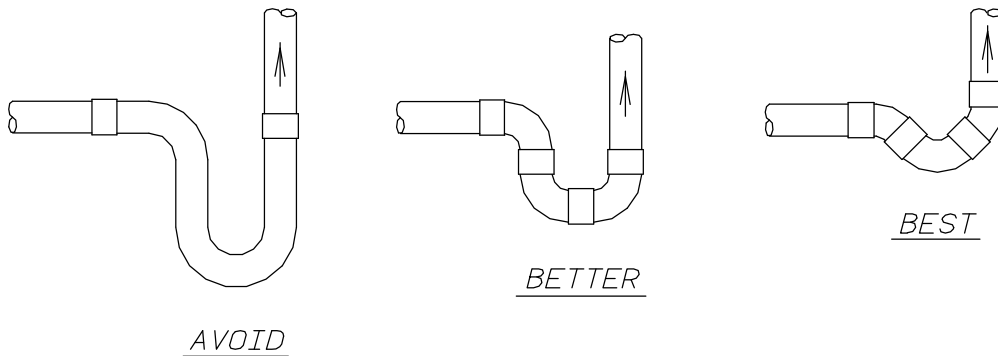

FIGURE 3-6
Minimum Traps For Discharge Lines

*Note: Each recommended line size is based on use of Type "L" copper tubing at a maximum equivalent distance of 150 feet. See TABLE 3-5 for equivalent feet of valves and fittings.

Air-Cooled Condenser Wiring

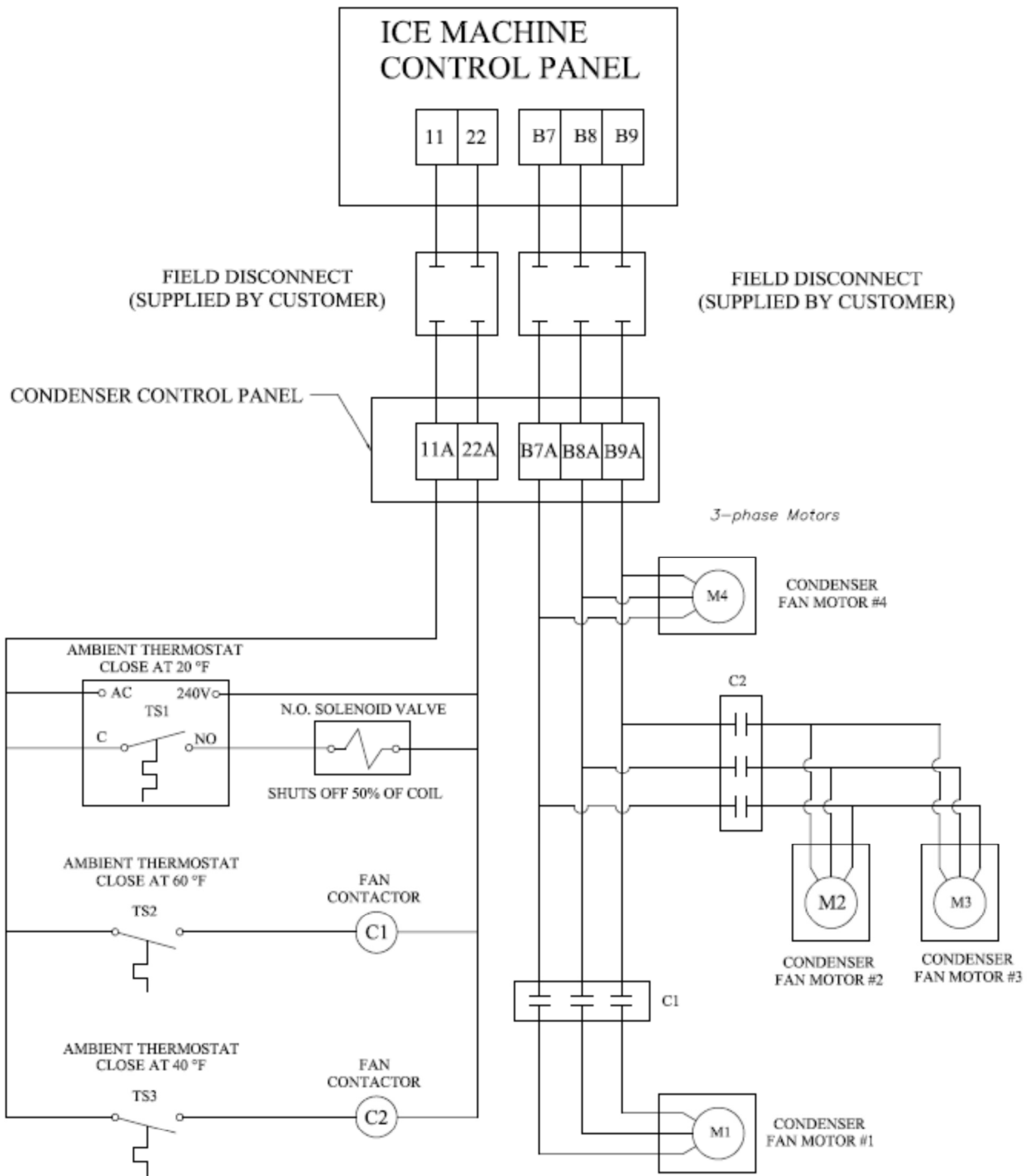

FIGURE 3-7
Wiring For BOHN BNHS04A029 with Cold Weather Valve and
Four Fans, 50/50 Condenser Split

INSTALLING YOUR TUBE-ICE® MACHINE

Air-Cooled Connections (See FIGURE 3-2A for connection sizes)

Follow these procedures to make a tight joint:

1. Silver solder or braze condenser tubing ends to the female Rota-lock connectors.
2. Remove dust caps if used, making sure that component plastic seals are intact.
3. Wipe off connector and spud threaded surfaces with a clean cloth to prevent the inclusion of dirt or any foreign material in the system.
4. Connector coupling nut should be screwed onto Rota-lock spud using the proper amount of torque.

Spud Size	Amount of Torque
7/8"	50-60 FT LBS
1 1/8"	80-100 FT LBS
1 3/8"	100-110 FT LBS

TABLE 3-6
Rota-lock Connector Torque Ratings

Pressure Relief Valves Pressure relief valves are installed on the freezer, receiver and the water cooled condenser. These valves are designed to vent in emergency conditions. This ensures vessel internal pressure does not exceed maximum allowable pressures.

Vent the relief valve outlet to a safe outdoor location in the approved manner away from people and building openings. Vent line piping must have drain line at low point to drain condensate from line per ASME Boiler and Pressure Code, Section VIII, Division 1.

PRESSURE RELIEF VALVES MUST BE REPLACED AFTER 5 YEARS OF SERVICE.

BEFORE REPLACING RELIEF VALVE, REVIEW REQUIREMENTS PER CURRENT LOCAL AND NATIONAL CODE.

VALVE REPLACEMENT SHOULD BE MADE BY PROPERLY TRAINED PERSONNEL ONLY.

NOTE: IF RELIEF VALVE DISCHARGES, VALVE MUST BE REPLACED AFTER DISCHARGING BECAUSE SETTING OR SEAT TIGHTNESS MAY BE ALTERED.

CONTACT VOGT ICE PARTS DEPARTMENT FOR REPLACEMENT VALVES.
PHONE: 502-635-3000

Ice Bin Thermostat Sensor (Optional) An electronic ice bin thermostat may be added to automatically cycle machine operation. To assure proper protection for the machine or auxiliary equipment, the sensor of the ice bin thermostat must be located so that ice will contact it when the bin is full (See FIGURE 3-8 for typical mounting bracket). The distance between the top of the ice bin and the sensor allows space for the machine to make an additional discharge of ice AFTER the ice contacts the probe. This will vary based on the size of the bin and the ice distribution system employed.

Note: The probe should also be mounted on the back side of the bracket, opposite of the front of the bin to reduce the possibility of damage from ice removal equipment.

The control panel is electrically connected so that the bin thermostat will stop the machine only upon the completion of a harvest period.

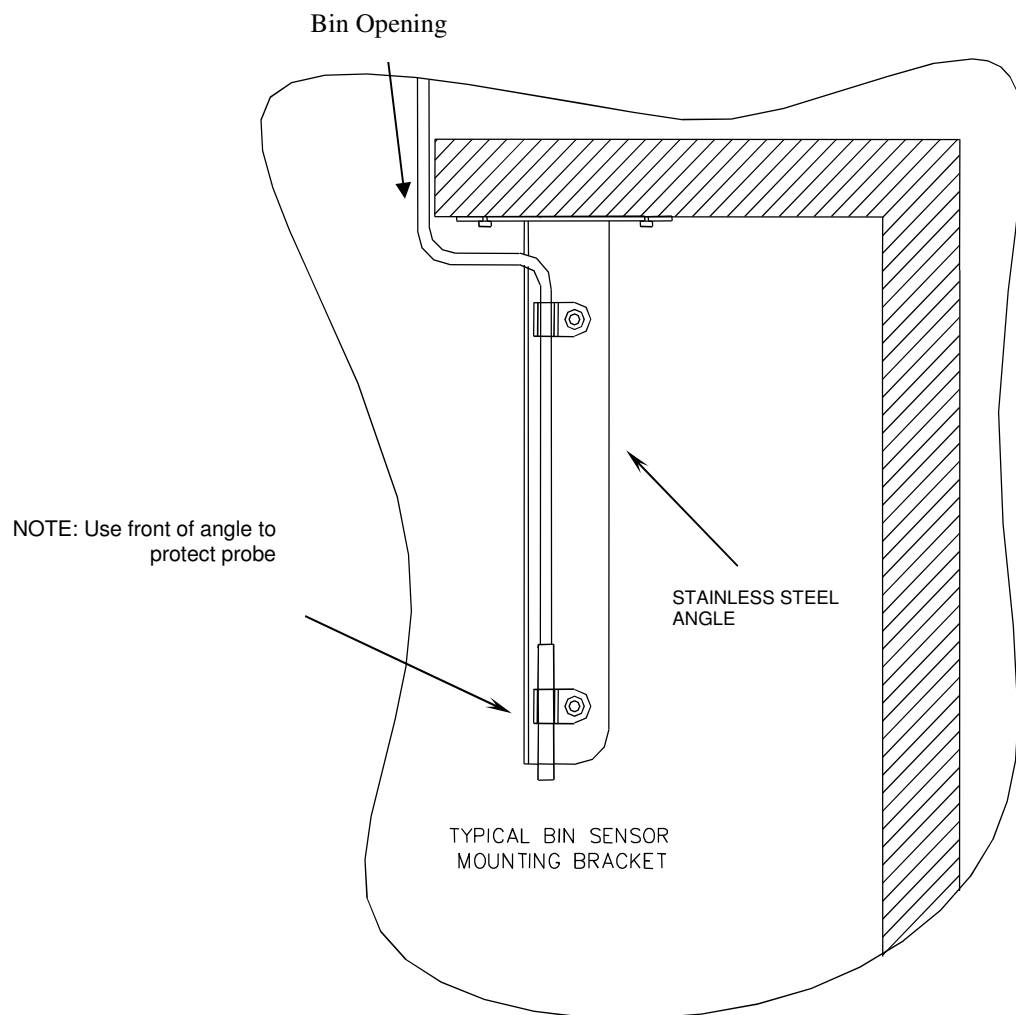

FIGURE 3-8

Typical Bin Sensor Mounting

Note: Actual location of sensor will vary based on bin layout and ice distribution system.

INSTALLING YOUR TUBE-ICE® MACHINE

Programming the Electronic Bin Thermostat

The electronic bin thermostat has an LCD readout that displays the temperature in the bin at the sensor. **The control has been preset and locked out at the factory to shut the machine down at 38°F and to re-start at 40°F.** The control retains the program even if power is cut to the machine. Under special conditions, the settings may need to be changed. The lockout switch is located on the inside of the control. Removal of the four screws on the face of the control will reveal the lock-switch.

Follow the instructions below to reset the switch.

1. Press the “SET” button to enter the sensors setup mode
2. Select between “C”- Celsius and “F” - Fahrenheit
Use the up ↑ or down ↓ key to select “F”
3. Press the “SET” button to set the Set point (S1 will be blinking)
Use the up ↑ or down ↓ key to set the temperature at 38°F
4. Press the “SET” button to set the Differential (DIF 1 will be blinking)
Use the up ↑ or down ↓ key to set the differential at 2°F
5. Select between “C1”- Cooling mode and “H1” - Heating mode
Use the up ↑ or down ↓ key to select “C1”

Machine will shut off when temperature drops to 38°F and come on when temperature reaches 40°F.

Note: The sensor will automatically exit the programming mode if no keys are depressed for a period of thirty seconds. Any settings that have been input to the control will be accepted at that point.

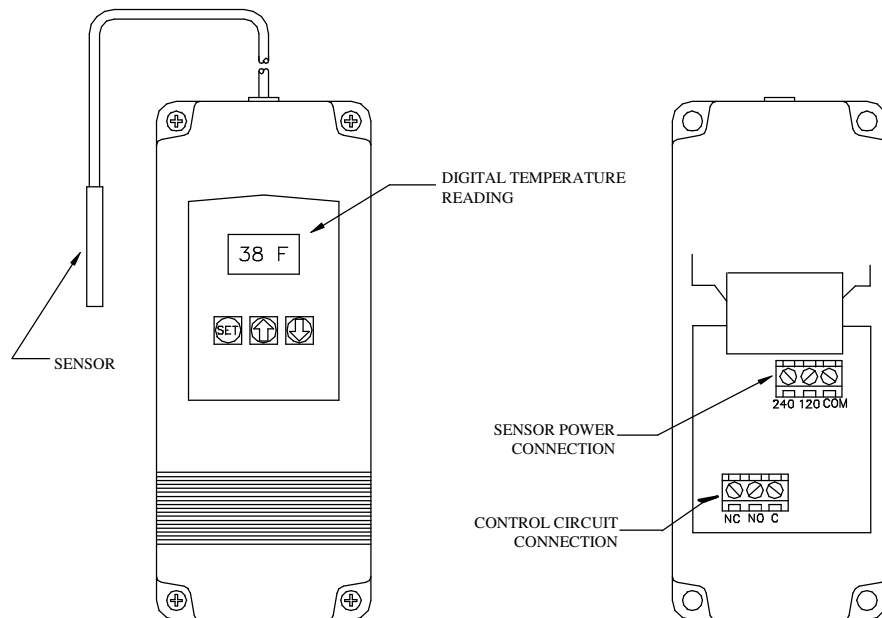

FIGURE 3-9
Electronic Thermostat

Note: If damaged, the sensor can be replaced without replacing entire unit.

Replacement sensor part #12A 2117G0901. Electronic temperature control part #12A 2117G09. Sensor cable can be extended up to 400 feet. For more information, consult Tube-Ice® Technical Service Department.

! IMPORTANT !
Be sure to follow the wiring schematic and electrical specification table when incorporating overloads. This is necessary to provide proper protection for the Tube-Ice® machine and its component parts.
! IMPORTANT !

Installation Review: A Checklist. Make a visual check to be sure these steps have been taken BEFORE continuing.

- CHECK: ___ PRIOR TO OPENING VALVES, check all joints for leaks which may have developed during shipment.
(NOTE: the machine was shipped with a positive pressure of 20-25 PSIG, verify on the freezer pressure gage.)
- CHECK: ___ All refrigerant piping, water supply and drain connections for conformity to requirements stipulated in this manual and properly connected to inlets and outlets.
- CHECK: ___ Electrical supply for proper size of fuses and for compliance to local and national codes. See the machine nameplate for minimum circuit ampacity and maximum fuse size.
- CHECK: ___ All field installed equipment (augers, conveyors, cooling towers, bin level controls, etc.) for proper installation.
- CHECK: ___ The applicable portion of the warranty registration/start-up report for proper completion.
- CHECK: ___ Cutter gear reducer oil level oil should run out of side pipe plug when removed.
- CHECK: ___ The water distributors at top of freezer to make sure they are all in position

! CAUTION !
The compressor crankcase heater should be energized for a minimum of Two (2) hours before attempting to start the compressor.
! CAUTION !

INSTALLING YOUR TUBE-ICE[®] MACHINE

BLANK PAGE

4. How Your Tube-Ice[®] Machine Works

Principle Of Operation. For a detailed description of the functions of each control panel components, see Section 6. Operation of the machine is controlled by “Clean/Off/Ice”, “Start” and “Stop” switches located in the control panel of the freezing unit. Automatic operation can be controlled by optional ice bin thermostats which will automatically stop and start the ice maker by the level of the ice in the storage bin (NOTE: See “Ice Bin Thermostat Typical Installation” for instructions on installation of the control bulb of the ice bin thermostat, FIGURE 3-8). The type ice produced (cylinder or crushed) is determined by how the machine cutter is set-up (cylinder is standard, crushed is optional). The control wiring is arranged so that the unit will stop only upon the completion of a thawing period whether by action of the “Clean/Off/Ice” switch or the ice bin thermostat.

The “Clean/Off/Ice” switch must always be set in the “Ice” position during normal ice-making operation. It is set in the “Clean” position only when the equipment is to be cleaned as outlined in the “Cleaning Procedure”, Section 7 and instructions attached to the machine.

If it should become necessary to instantly stop the machine, push the “Stop” button. To restart the machine, push the “Start” button.

FIGURES 4-1 & 4-2 illustrate the piping diagram of the refrigerant and water circuits of the Tube-Ice[®] machines with numbers for easy reference. Throughout this manual, the numbers you see in parentheses refer to the numbers in this piping schematic.

The freezer (2) is a shell and tube-type vessel. During the freezing period, water is constantly recirculated through the vertical tubes of the freezer by a centrifugal pump (6). Make-up water is maintained by a float valve (12) in the water tank (7). Solenoid valve (20), sometimes referred to as the “A” valve, is open and solenoid valve (18), sometimes referred to as the “D” valve, is closed.

Refrigerant gas from the top of the freezer (2) passes through the suction accumulator (88), the heat exchanger (13), and to the compressor (3). Here the cool gas is compressed to a high temperature, high pressure gas which discharges through the oil separator (14) and into the condenser (15). In the condenser, heat is removed and the gas is condensed to a high temperature, high pressure liquid. The high pressure liquid goes through the accumulator boil out coil (88) and suction line heat exchanger (13) where it gives up heat to the suction gas for compressor protection. In addition, this liquid is subcooled and carried to the receiver (15R). Condensed liquid refrigerant from the receiver flows through the thawing chamber (16) of the freezer, the filter/drier (46), the “A1” and “A2” liquid feed valves (20) & (21) and then the expansion valve (17) and capillary. At the expansion valve (17) and capillary feed, the refrigerant is taken from a saturated liquid state of relatively high pressure and expanded to a very low pressure, low temperature liquid. The “A2”(21) solenoid and capillary feeds liquid to the freezer (2) during the entire freeze cycle. The float switch (22) is wired to the “A1” solenoid valve (20). The float switch energizes and de-energizes the “A1” solenoid in response to the level of refrigerant in the freezer. The cold liquid refrigerant enters the freezer where it absorbs heat from the circulating water. This cool gas is pulled out of the freezer at the suction outlet thereby completing the circuit.

The freezing period is completed by action of the freezer pressure switch in the control panel. The water pump (6) is stopped and solenoid valves “A1” & “A2” (20) & (21) are closed. The thawing period then begins. Solenoid valve “D” (18) is opened, the cutter motor (5M) is started and the harvest (thaw) timer is activated. Warm gas from the receiver is discharged into the freezer through valve (18), thereby slightly thawing the outer edge of the ice which drops on the rotating cutter for sizing. See “Freezer Period and Harvest Period” for more detailed description of operation.

HOW YOUR TUBE-ICE MACHINE WORKS

Air-cooled machines have a solenoid valve (53), sometimes referred to as the “X” valve, in the compressor discharge line, and a check valve (101) in the liquid return line to the receiver. These valves prevent the migration of refrigerant when the machine is not operating. The "X" valve is open any time the compressor is running.

Freeze Period. The Tube-Ice[®] is frozen inside the stainless steel tubes in the freezer (2) by the direct application of refrigerant to the shell side (outside) of the tubes. The ice is produced from constantly recirculating water during the freeze period. As the ice thickness increases, the freezer suction pressure decreases. At a set pressure, the freezer pressure switch initiates the harvest period.

Harvest Period. When the freezer pressure switch (56, FPS) contact closes, a control relay (CR) is energized. The “CR” relay stops the water pump and starts the cutter motor. The “A1” & "A2" liquid line solenoid valves close, the “D” (thaw gas) solenoid valve opens and the thaw timer (T) is energized.

The defrost pressure switch (dps) will open and close the "D" valve to maintain the proper pressure to get the ice to release but not add unnecessary heat. As the ice releases and drops through the rotating cutter and onto the cutter disc, it is discharged through the side opening of the water tank. The harvest timer (T) is to be set for the time required to discharge all the ice plus 30 seconds longer (usually 2 1/2 minutes).

! CAUTION !
Make sure all the ice clears the freezer with at least 30 seconds to spare before the next freeze period begins. This is to prevent refreezing.
! CAUTION !

1	Control Panel	30	Receiver Sight Glass
1PG	Suction Pressure Gauge	31	Gage Glass Stop Valve
2PG	Discharge Pressure Gauge	32	A/C Condenser Service Connection
2	Freezer	34	Compressor Suction Service Valve
3	Compressor	35	Compressor Discharge Service Valve
4PS	Dual High/Low Pressure Switch	37	Oil Charging/Drain Valve
5M	Cutter Motor	39	Water Tank Drain Valve
5R	Gear Reducer	40	Automatic Water Tank Blowdown
6	Water Pump	41	Condenser Water Regulator (W/C Machines)
7	Water Tank (includes cutter assembly)	41A	Condenser Pressure Control (A/C Machines)
8	Water Distributing Chamber	43	Strainer
12	Make-Up Water Float Valve	44	Receiver Drain Valve
13	Heat Exchanger	46	Filter Drier
14	Oil Separator	48	Muffler
15	Condenser	50	Receiver Safety Valve
15R	Receiver	51	Freezer Safety Valve
16	Thawing Chamber	53	Cold Weather Solenoid Valve “X” (A/C Machines)
17	Expansion Valve	55	Discharge Line Stop Valve For A/C Machines
18	Thawing Gas Solenoid Valve “D”	56	Freezer/Pressure Switch
18S	Thawing Gas Pressure Switch	58	Liquid Outlet Valve (King Valve)
20	Liquid Feed Solenoid Valve “A1”	59	Receiver Purge Valve
21	Liquid Feed Solenoid Valve “A2”	69	Freezer Pressure Stop Valve
22	Float Switch	70	Oil Return Stop Valve
23	Condenser Water Inlet W/C Machines	88	Accumulator/Heat Exchanger
23A	Make-Up Water Inlet 3/4 FPT	90	Thawing Gas Stop Valve
24	Condenser Water Outlet (W/C Machines)	91	Receiver Liquid Return Stop Valve
25	Water Tank Drain Connection (1” FPT)	94	Compressor Oil Pressure Safety Control
28	Refrigerant Charging Valve	101	Check Valve

TABLE 4-1
Piping Nomenclature

HOW YOUR TUBE-ICE MACHINE WORKS

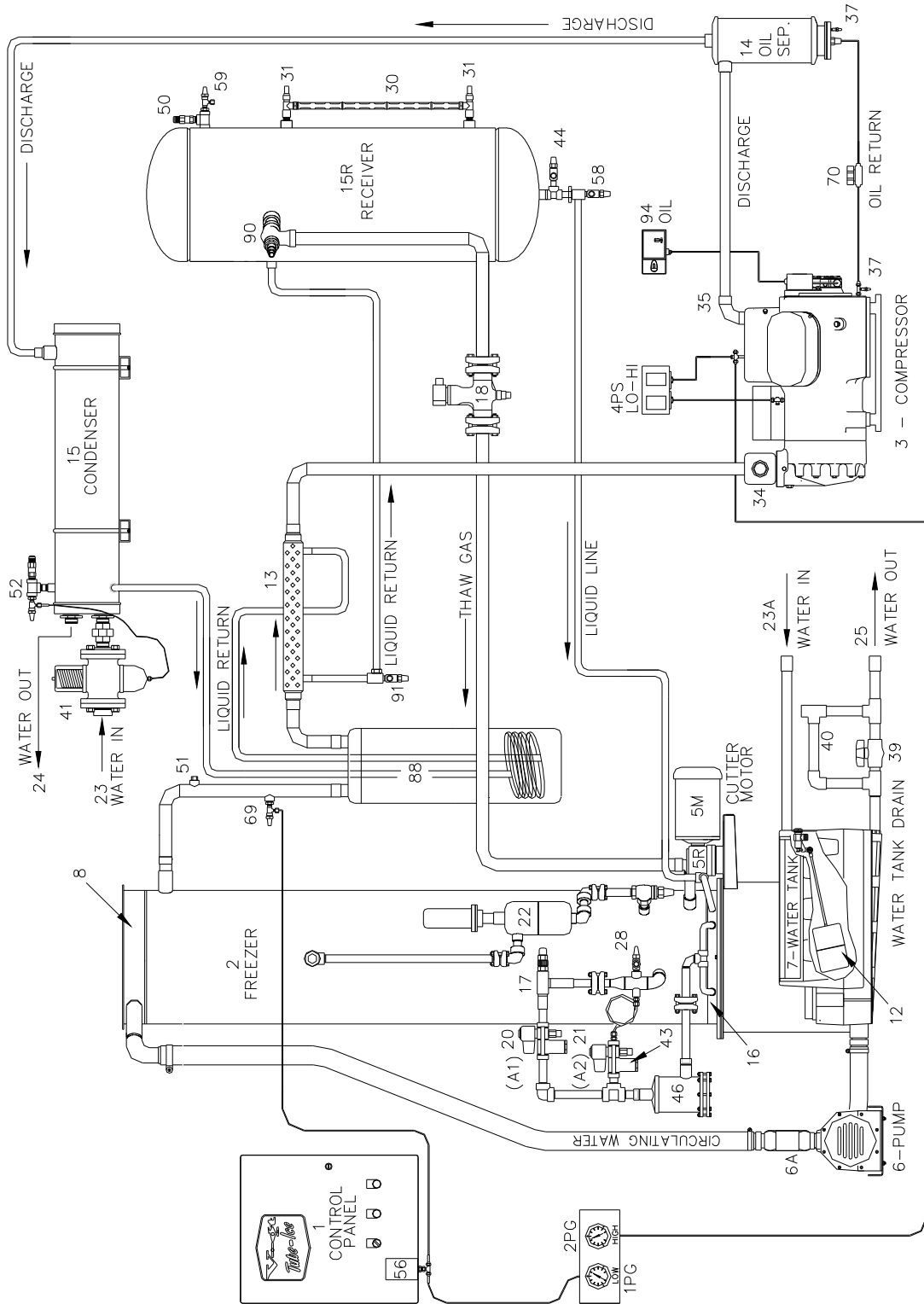

FIGURE 4-1
Water Cooled Piping Schematic

HOW YOUR TUBE-ICE MACHINE WORKS

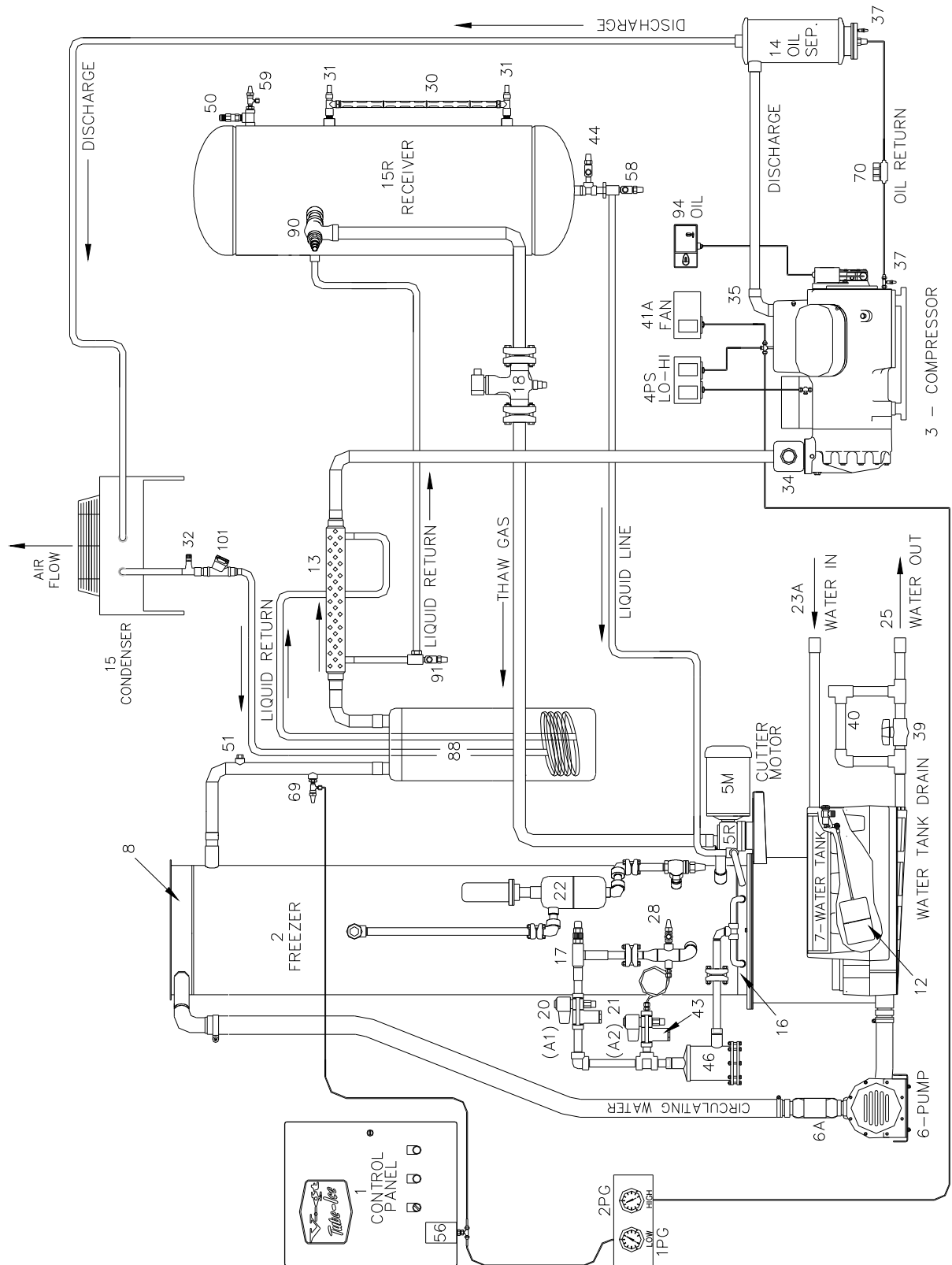

FIGURE 4-2
Air-Cooled Piping Schematic

Start-Up and Operation

Refrigeration System Review The refrigeration system uses R-22 or R-404a refrigerant, a compressor, a refrigerant float switch, expansion valve, a flooded evaporator (freezer), and warm gas defrost. Following the schematic, you see that during the freeze period of the machine's cycle, the condenser discharge gas leaves the compressor and goes to the condenser where it is condensed into liquid by the removal of heat by either air or water passing through the condenser. A reservoir of liquid is accumulated in the receiver and flows as required, passing through the thawing chamber (a lower separate section of the freezer) then the filter/drier. The liquid feed solenoid valves ("A1" and "A2") being open during the freeze cycle allows the liquid to be metered by the float switch as the "A1" valve opens and closes in response to the refrigerant level in the freezer. Wet refrigerant floods the evaporator and is in contact with the outside of the ice-making tubes in which water is being circulated. The heat contained in this water passes through the wall of the tubes, lowering the temperature of the water, causing it to freeze and form a long tube of ice that adheres to the inside of each of the freezer tubes. The flowing water keeps the accumulated ice clear by washing separated solids down into the sump area of the water tank.

The wet suction gas leaves the freezer and any remaining liquid droplets are removed by the accumulator and suction line heat exchanger. The dry gas enters the compressor and is compressed then discharged to the condenser completing the cycle.

As the ice is formed in the freezer, the suction pressure steadily reduces until it causes the freezer pressure switch to close, initiating the harvest period.

During the harvest period, the thawing gas solenoid valve, (the "D" valve), is open allowing the warm high pressure gas to enter the freezer. This heat melts a thin film from the outside of the ice, reducing the diameter and letting it fall free from the freezer tubes. This period lasts approximately 2 1/2 minutes.

Refrigerant Charge Included with the machine is the required charge (approximately 500 lbs.) of Refrigerant (R-22 or R-404a, depending on the model), which has been isolated in the receiver (15R). Before shipment of the machine, the compressor service valves (34), (35), and the stop valves in the various lines to the condenser and receiver have been closed. These valves are tagged with instructions that the valves are to be opened prior to start-up of the machine. Before opening these valves, it is advisable to check all joints for leaks that may have developed during shipment. If no leaks are present, a positive pressure should show on the suction and discharge pressure gages. They should indicate a pressure approximately equal to the ambient temperature. This pressure can be found using the pressure temperature chart for the applicable refrigerant, TABLE 11-7.

If it should ever become necessary to add refrigerant to the system, charging valve (28) is provided for this purpose. Through this valve, refrigerant can be added in liquid form. See "Adding Refrigerant." The compressor crankcase heater must be energized for a minimum of two hours prior to starting and running the compressor.

START-UP AND OPERATION

Start-up Checklist. Be sure to complete and return the “Warranty Registration/Start-Up Report” located at the front of the manual.

- _____ 1. See that water-inlet and outlet connections are attached properly. The water inlet shutoff valves for the water tank and condenser should be open. The water level in the water pan should be at a height where the make-up water float valve will be closed when the machine is idle.
- _____ 2. See that the cutter motor gear reducer is lubricated (see Section 7 “Lubrication” Cutter gear reducer (5R) for instructions).
- _____ 3. See that compressor crankcase oil level is at proper height of 1/4 to 1/2 of the sight glass.

NOTE
All valves are tagged with instructions.
NOTE

- _____ 4. Open compressor service valves (34 and 35), the hand-stop valve (90) in the thawing gas line, the receiver liquid return stop valve (91) in the condenser return line, hand-stop valve (58) in the liquid line, hand-stop valve (69) to the freezer pressure switch, top and bottom float switch hand stop valves (22A) and stop valve (70) in the oil return line. These valves are tagged to indicate that they were closed for shipping purposes. Gage glass valves (31) on the receiver can be opened for liquid level observation but should remain closed for unattended operation.
- _____ 5. **IMPORTANT! CHECK TO SEE** that all stop valves in the various refrigerant lines are open except charging valves (28 & 44), according to the attached tags.
- _____ 6. Immediately after opening all valves, entire machine should be checked for refrigerant leaks with electronic leak detector.
- _____ 7. See that “Ice/Off/Clean” Switch (SS) is in the “Ice” position.
- _____ 8. Close exterior disconnect switch to energize crankcase heater and check for compliance to nameplate.

Start-Up

FIGURE 5-1
Control Panel Switch Layout

Starting Procedure (Initial Start-Up):

(NOTE: The machine will start in the harvest mode when set to “Ice”)

1. Set the “Clean/Off/Ice” selector switch to the “Clean” position.
2. Push the “Start” button (PB2) to start the water pump.
3. The pump can be stopped and started by the “Stop” and “Start” push buttons. Water should be circulated for a minimum of five (5) minutes to prime the pump, purge the tubing of air and lubricate the cutter bearing.

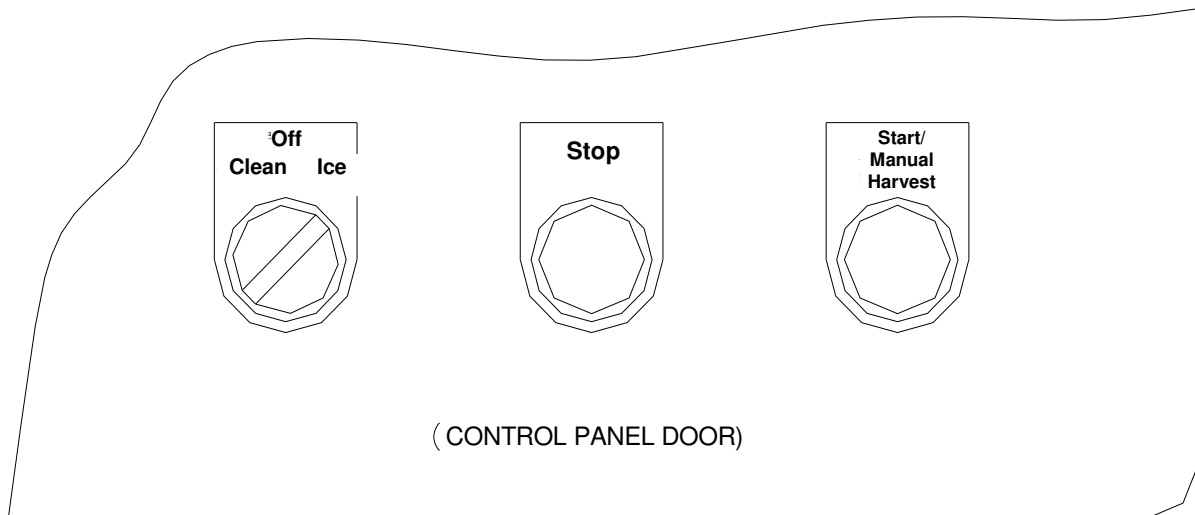
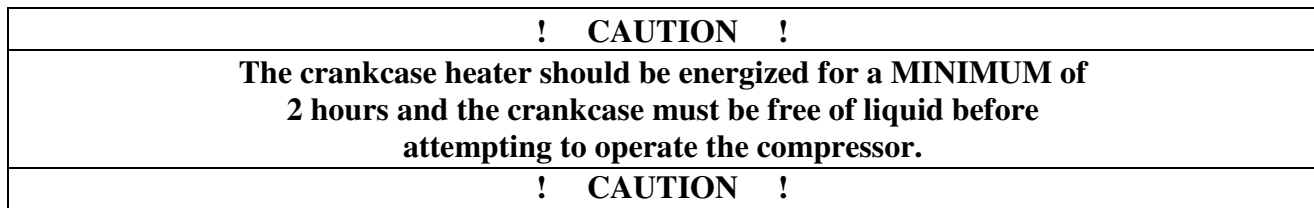
Note: If pump is already primed skip steps 1-3

4. When there is good water flow, turn the “Clean/Off/Ice” selector switch to “Ice”. The machine will then start in a harvest (thaw) period with the compressor running.
5. At the termination of the harvest (thaw) period, the machine will begin the freeze period.
6. Be sure to observe a minimum of four (4) cycles of ice production to confirm the satisfactory operation of the machine (approximate time for four cycles is 60-80 minutes).

Complete the remaining part of the “Warranty Registration/Start-Up Report” upon initial machine start-up and return it to Vogt Ice, LLC.

START-UP AND OPERATION

Shut-down

! CAUTION !
The red “Stop” button should only be used for emergency shutdown. For normal shutdown use the “Clean/Off/Ice” button.
! CAUTION !

1. Set the “Clean/Off/Ice” switch to the “Off” position. Do not use the machine disconnect to stop the machine. If the disconnect is used the crankcase heater will be de-energized and liquid refrigerant will migrate to the compressor.
2. If in a freeze mode, the machine will continue to run.
3. At the completion of the freeze cycle the machine will harvest and stop. The completion of a cycle ensures that all ice is removed from the freezer to prevent refreeze when the machine is restarted.
4. If in a harvest, the machine will complete the harvest and stop.

Operating Tips

- If the operation of your machine is not controlled by a timer, bin level control or some other mechanism to automatically start and stop ice production, you should use ONLY the “Clean/Off/Ice” toggle switch to start and stop machine.
- By turning the “Clean/Off/Ice” selector switch to “Off”, the machine will stop after the next harvest cycle.
- Do not use the “Stop” push button or the machine disconnect for normal shutdown of the machine.
- Throw the “Disconnect” only in an emergency or for safety when performing certain service or repairs to the machine. The compressor crankcase heater is de-energized when the disconnect is thrown.
- The “Start” push button can be used to initiate a harvest cycle. When it is pushed during a freeze cycle, it will immediately initiate a harvest cycle.

Adding Refrigerant**! CAUTION !**

If it should become necessary to add refrigerant to the system, charging valve (28) is provided for this purpose. Be sure to follow all local and federal regulations regarding the handling of refrigerants and their illegal emission into the atmosphere.

! CAUTION !

Check the refrigerant level after the machine has operated for a few cycles. It should be slightly above the minimum operating level, as indicated on the receiver, a few minutes prior to start of a thawing period. If this level is low at this time, sufficient refrigerant should be added to the system to raise the level above this point. Add only a small quantity (10 lbs. or less) at a time and operate the machine several cycles to check the level before adding additional refrigerant. Refrigerant may be added as a liquid through the charging valve (28) only while the machine is operating. It is important that no air or other non-condensable gas enter the system when charging refrigerant into the unit. It is also possible to check the refrigerant level by pumping machine down (See 9-12). When the machine is pumped down, a liquid level should be observed in the gage glass on the receiver.

Refrigerant Charging Procedure:

1. Make connection between charging valve and refrigerant cylinder using hose or pipe suitable for R-22 or R-404a service. See instruction card attached to refrigerant cylinder.
2. Open valve on cylinder and purge air out of charging line at the charging valve connections.
3. Open charging valve.
4. Refrigerant can be added only during the freeze cycle. The charging valve must be closed when the freezer is in a harvest.

In order to check the total charge in the system, it is necessary to transfer all of the refrigerant to the receiver. A total pump down procedure should be performed. See the name plate for the approximate refrigerant charge for the machine. Remember, the total charge will vary for air-cooled machines with remote air-cooled condensers.

! DANGER !

Immediately close system charging valve at commencement of defrost or thawing cycle if refrigerant cylinder is connected. Never leave a refrigerant cylinder connected to system except during charging operation. Failure to observe either of these precautions can result in transferring refrigerant from the system to the refrigerant cylinder, overfilling it, and possibly causing the cylinder to rupture because of pressure from expansion of the liquid refrigerant.

! DANGER !

START-UP AND OPERATION

BLANK

6. Electrical Controls

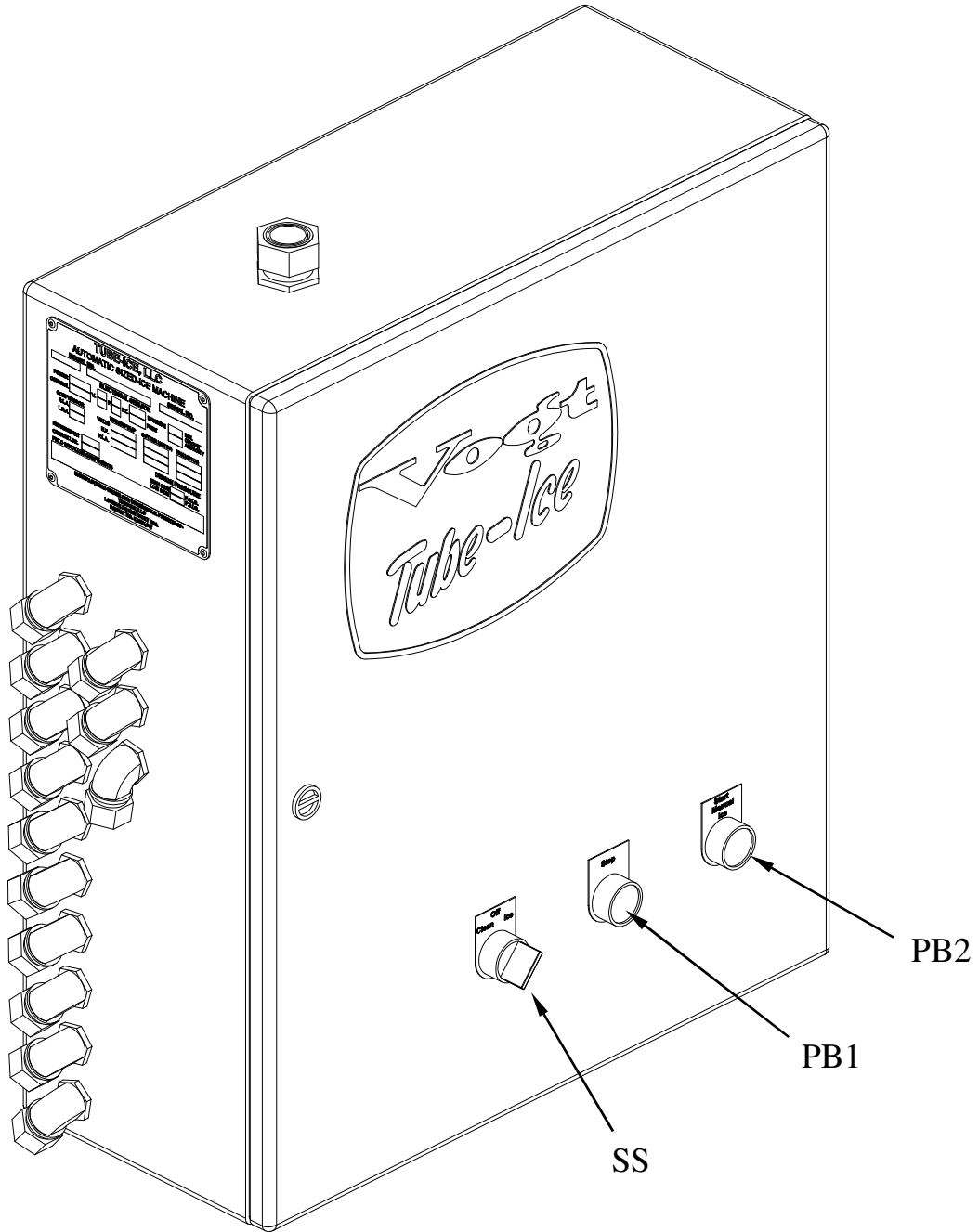

FIGURE 6-1
Control Panel

ELECTRICAL CONTROLS

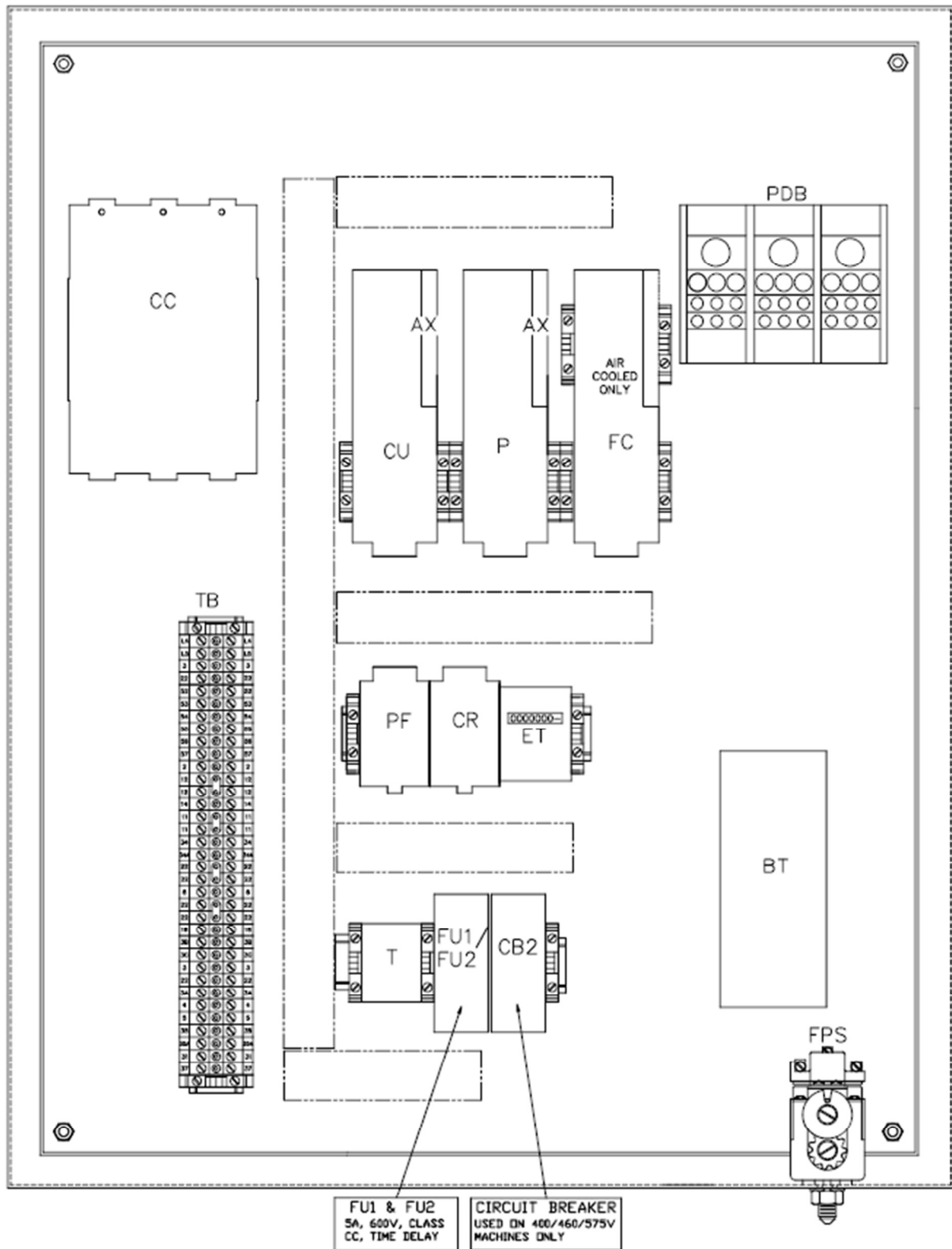

FIGURE 6-2
Control Panel Components (Standard)

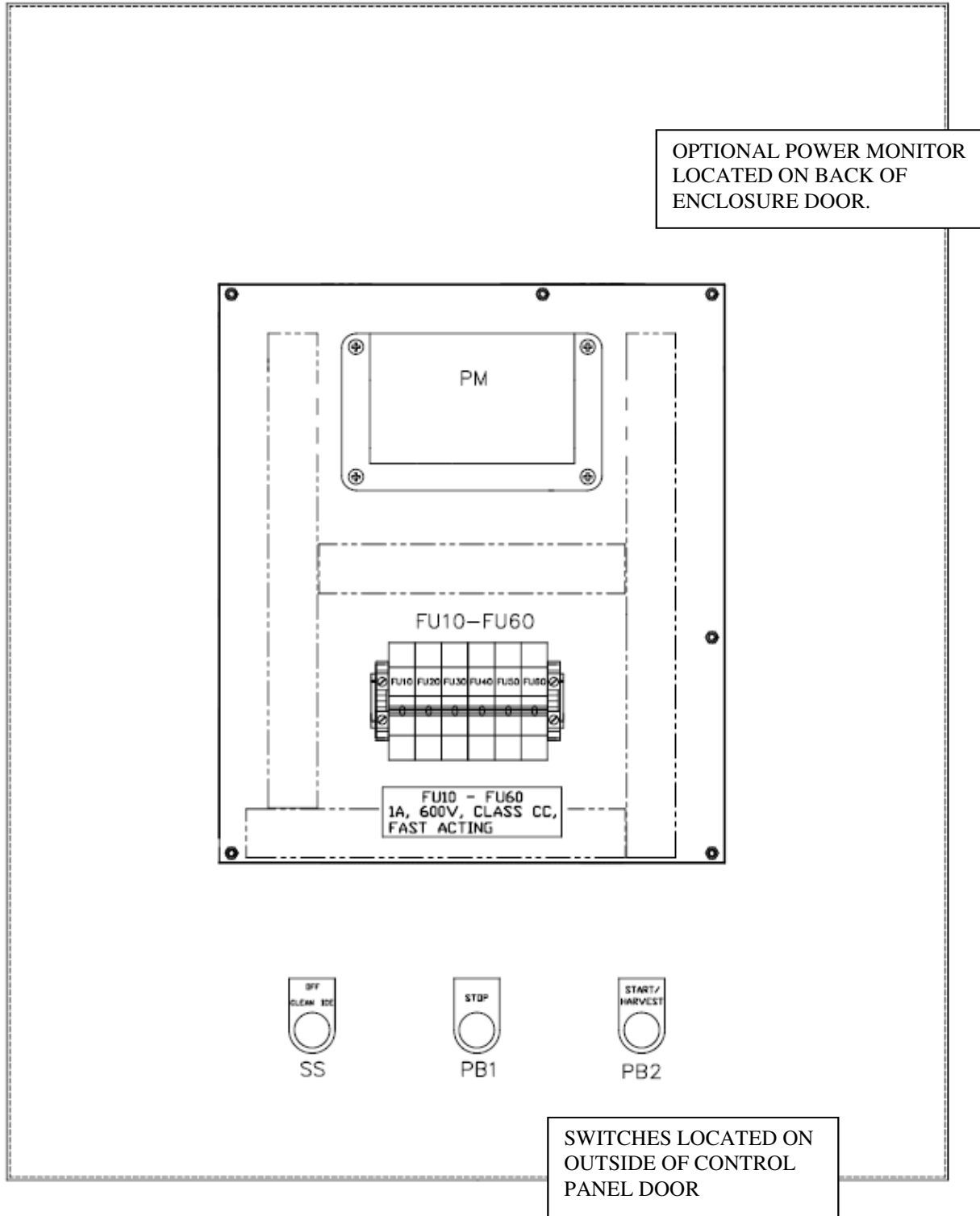

FIGURE 6-2A
Control Panel Door (Standard) and Optional Power Monitor

ELECTRICAL CONTROLS

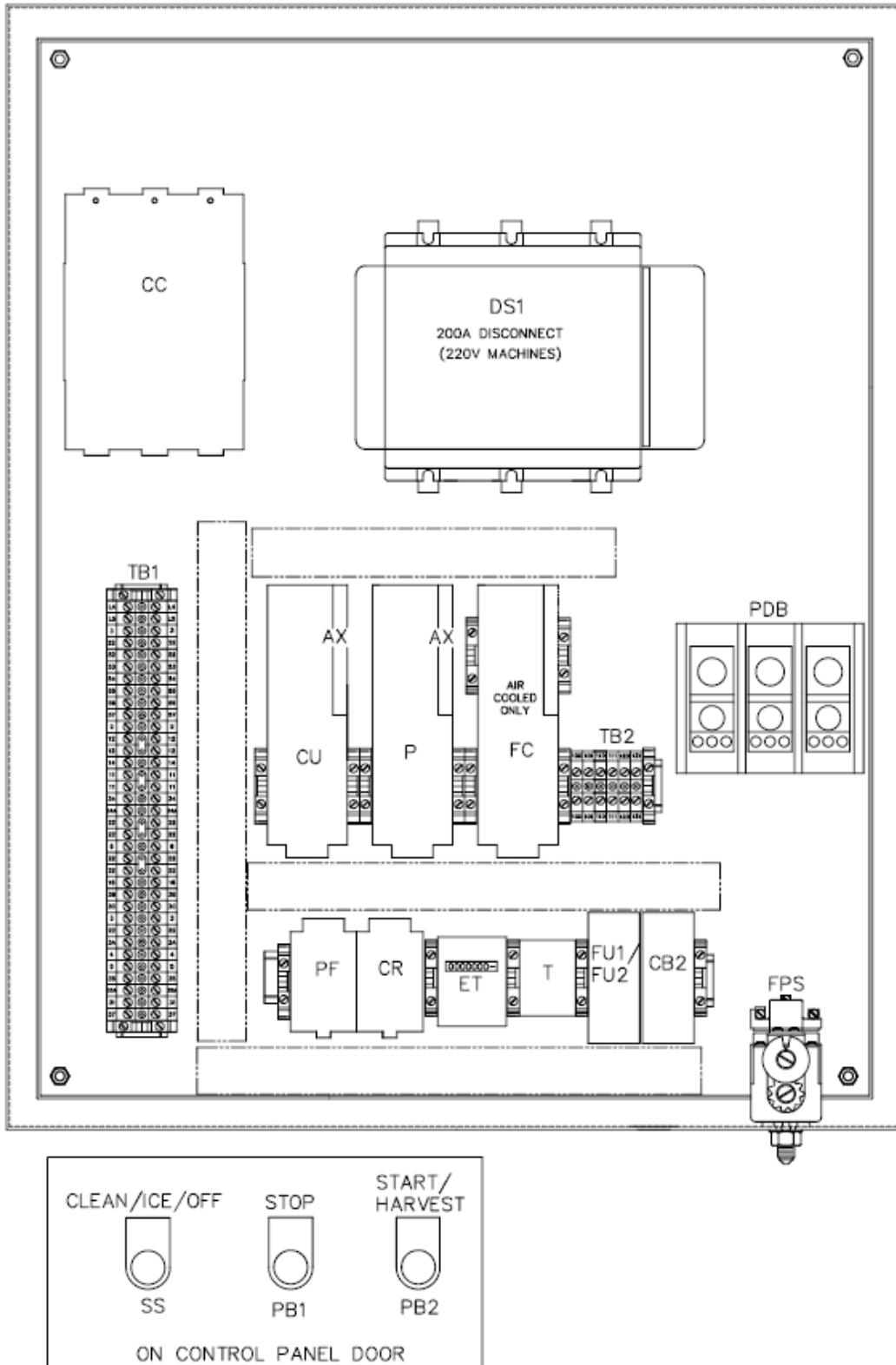

FIGURE 6-2B
Control Panel Components (CE & Australian Approved)

Item No.	Vogt Part No.	Description
AX	12A7518E33UL	Aux Trip Indicator, 6A, 1NO / 1NC
BT	12A2117G09	Bin Thermostat (Optional)
CB2	12A7515E22	Control Circuit Breaker, 6 Amp, 2 Pole (400V & 460V machines only)
CC 400/460V	12A7516E30	Compressor Motor Contactor (72 Amp, 3 Pole)
	12A7518E30	Aux. Contact (10 Amp, 1 N.O./1 N.C., Side Mount)
	12A7518E31	Aux. Contact (10 Amp, 2 N.O., Side Mount)
	12A7518E32	Aux. Contact (5 Amp, 2 N.O., Top Mount)
CC 200V, 208/230V	12A7516E48	Compressor Motor Contactor (140 Amp, 3 Pole)
	12A7518E43	Aux. Outside Contact (2 Amp, 2 N.O., Side Mount)
	12A7518E44	Aux. Inside Contact (2 Amp, 2 N.O., Side Mount)
CR	12A7517E27	Control Relay (10 Amp, 2 N.O./2 N.C., 208/240V Coil)
CU	12A7516E23	Contactor (9Amp, 3 Pole, with 1 N.O. Aux, 208/240V Coil)
	12A7530E52UL	Cutter Manual Motor Starter, 0.63-1.0A (460V, 60hz)
	12A7530E53UL	Cutter Manual Motor Starter, 1.0-1.6A (400V, 50hz)
	12A7530E54UL	Cutter Manual Motor Starter, 1.6-2.5A (200/208/230V, 50/60hz)
ET	12B7503E17	Timer, Elapsed, Panel Mount, 220V (50Hz)
	12B7503E18	Timer, Elapsed, Panel Mount, 220V (60Hz)
FC Air Cooled Only	12A7516E27	Condenser Fan Contactor (30 Amp, 3 Pole, 1 N.O. Aux. Contact, 208/240V Coil)
	12A7530E58UL	Fan Manual Motor Starter, 10.0-16.0A (400/460V, 50/60hz)
	12A7530E63UL	Fan Manual Motor Starter, 23.0-32.0A (200/208/230V, 50/60hz)
FPS	12A2117E04	Freezer Pressure Switch
FU1 & FU2	12A7504E18	Fuses, 5A, 600V, Class CC, Time Delay
FU10-FU60	12A7504E29	Fuses, 1A, 600V, Class CC, Fast Acting (For use w/optional Power Monitor)
P	12A7516E23	Contactor (9Amp, 3 Pole, with 1 N.O. Aux, 208/240V Coil)
	12A7530E55UL	Pump Manual Motor Starter, 2.5-4.0A (400V/460V, 50/60hz)
	12A7530E56UL	Pump Manual Motor Starter, 4.0-6.3A (208/230V, 60hz)
	12A7530E57UL	Pump Manual Motor Starter, 6.5-10.0A (200V only)
PB1	12A7500E57	Stop Push Button (Red)
	12A7500E76	Contact Block/Mounting Latch (1 N.C.)
PB2	12A7500E56	Start Push Button (Green)
	12A7500E73	Contact Block/Mounting Latch (2 N.O.)
PM	12A7700P01	Power Monitor, Universal Phase Protector (Optional)
PF	12A7516E23	Power Failure Contactor (9 Amp, 3 Pole, 1 N.O. Aux. Contact, 208/240V Coil)
SS	12A7500E61	Selector Switch, 3 Position
	12A7500E77	Contact Block/Mounting Latch (2 N.O./1 N.C.)
T	12A7503E22	Thawing Timer (Delay On Make) 100-240V
	12A7503E39	Timer Base (8 Pin, Guarded Terminal)
TB1 & TB	N/A	Main Terminal Block Assembly
TB2	N/A	Terminal Block Connections for Customer (CE & Australian Approval)

TABLE 6-1

Control Panel Components and Part Numbers (See FIGURE 6-1, 6-2, 6-2A & 6-2B)

ELECTRICAL CONTROLS

Description of Component Function	
AX –	Auxiliary trip indicator for manual motor starters. Switches when cutter or pump motor starter trips.
CB2 –	Overload and short circuit protection for control circuit and crankcase heater. (400/460V machines only)
CC –	Provides power to the compressor motor. Continuously energized during freezing and thawing. Auxiliary contacts control main power for control circuit components, crankcase heater, control relay and harvest timer.
CR –	Controls sequencing of Freezing and Thawing circuits. Energized during thawing period.
CU –	Cutter Motor Starter (Manual motor starter and contactor). Starts and stops cutter motor. Provides short circuit and over current protection. Stops cutter motor and ice machine in the event of a mechanical or electrical malfunction that results in excessive motor amperes.
DS –	Disconnect switch (CE and Australian Approved machines only)
ET –	Indicates hours of machine operation. Energized when compressor is operating.
FC –	Cutter Motor Starter (Manual motor starter and contactor). Cycles the fan motor(s) of air-cooled condenser on and off. Activated by the condenser pressure switch (Air-cooled Machines ONLY). Provides short circuit and over current protection. Stops fan motors in the event of a mechanical or electrical malfunction that results in excessive motor amperes.
FPS –	Regulates the ice thickness by reading freezer pressure and initiating the thaw period at the set point.
FU1&2 –	Overload and short circuit protection for control circuit and crankcase heater.
FU10-60 –	Short circuit protection for optional Power Monitor.
P –	Pump Motor Starter (Manual motor starter and contactor). Starts and stops pump motor. Provides short circuit and over current protection. Stops water pump motor in the event of a mechanical or electrical malfunction that results in excessive motor amperes.
PB1 –	Used to stop machine immediately (Should be used for emergency stopping only).
PB2 –	Used for starting machine or manually harvesting. Will initiate a harvest cycle whenever pushed with the “Clean/Off/Ice” selector switch in the “Ice” position and machine operating in a freeze cycle.
PF –	Stops the machine when there is a power failure or interruption. Also, stops the machine when the high/low pressure switch, oil pressure safety control, pump overload, cutter overload, compressor overload or the control circuit breaker is tripped. If the “Stop” button was pushed, any of the safeties tripped, or there was a power outage, the machine must be manually restarted by pushing the “Start” button.
SS –	Used to select operating mode of machine. When in clean position, only the water pump will run. This allows cleaner to be circulated through the freezer without making ice. In the off position, the machine will shut down after the completion of a freeze and harvest period. In the ice position, machine will cycle on and off based on a control signal (i.e. bin thermostat or timer) or run continuously until manually stopped by setting the switch to the “Off” position.
T –	Controls the time of the thawing period.
TB&TB1 –	Main terminal block numbered for multiple wire connections and ease of troubleshooting.
TB2 –	Customer connections for auxiliary contacts on cutter, pump and compressor contactors. (CE & AUS approval)

TABLE 6-2
Description of Control Panel Component Function

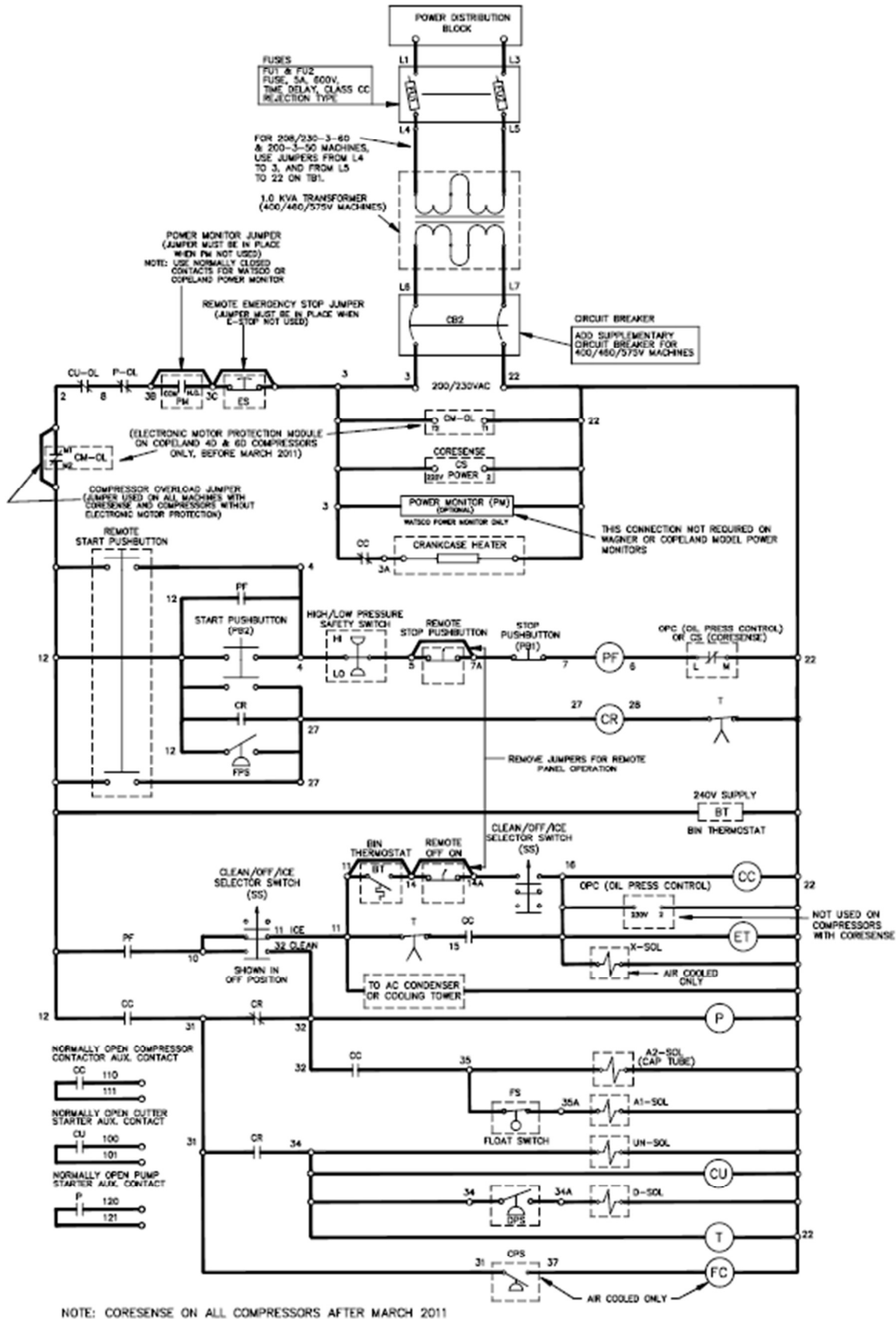

FIGURE 6-3
Control Circuit - Electrical Schematic All Voltages, 50-60 Hz.

ELECTRICAL CONTROLS

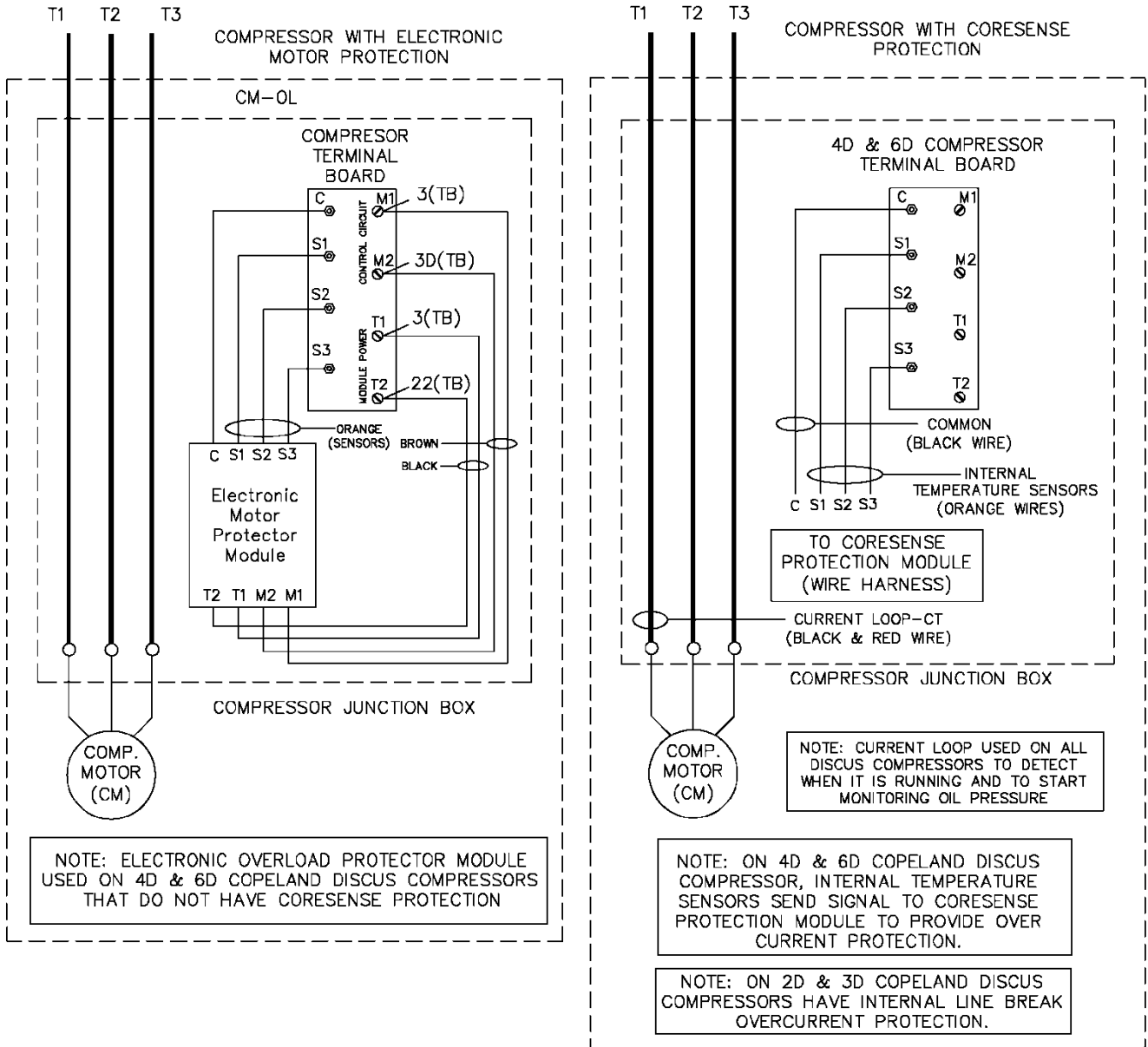

FIGURE 6-4
Compressor Schematic Detail All Voltages, 50-60 Hz.

BLANK

7. Maintenance

Ice Making Section. The ice-making section of the Tube-Ice[®] machine should be cleaned at least twice a year (more often if water conditions cause mineral build-up). Use an approved food-grade ice machine cleaner. The water pump is used to circulate the cleaner through the system by setting the “Clean/Off/Ice” selector switch to “Clean” and starting and stopping the pump by the “Start/Manual Harvest” and “Stop” switch. For complete instructions, refer to the “Cleaning Procedure” attached to the equipment and duplicated here.

NOTE: Before cleaning or sanitizing any Tube-Ice machine, pump the machine down and make sure the crankcase heater is working properly. This will eliminate the possibility of refrigerant migrating to the compressor while circulating warm water through the evaporator.

Cleaning Procedure

1. Before cleaning any Tube-Ice machine make sure the crankcase heater is working properly. When the crankcase heater is not working there is a possibility for refrigerant evaporated by warm circulating water to migrate to the compressor during the cleaning operation.
2. Set “Clean/Off/Ice” selector switch (SS) to the “Off” position. If the machine is running, it will shut down on completion of the next ice harvest period.
3. Remove ice from storage area or cover opening into it.
4. Shut off water supply and drain water tank (7) by opening drain valve (39). Remove any loose sediment from tank.
5. Close drain valve (39) and fill water tank (approximately 15 gallons) with warm water. Close the petcock on the water pump during the cleaning period.
6. Add 40 ounces (8 ounces per 3 gallons) of Nu-Calgon[®] ice machine cleaner or equivalent (food grade liquid phosphoric acid) to water tank during the refill period. Note: Tank capacity = 14.5 gallons
7. Inspect the water distributors by looking through clean freeze cover. If required, remove the cover. Clean and remove any solid particles from the distributor orifices (two orifices in each distributor). Clean the rubber cover gasket and reinstall the cover.
8. To run the pump only, set the selector switch (SS) to the “Clean” position and press “Start”.
9. Circulate cleaning solution until deposits are dissolved or solution is neutralized. Repeat cleaning if necessary.
10. Press “Stop” button to stop pump, then drain and flush water tank with fresh water. Open water supply to machine.
11. Drain and flush tank and then refill with fresh water.
12. Clean inside of ice storage area and remove any solution that entered during the cleaning process. Remove cover if one was installed over opening into storage area.
13. Start ice-making cycle by setting the “Clean/Off/Ice” selector switch (SS) to “Ice”. Check for water leaks around the freezer cover and tighten nuts if needed.
14. Adjust setting of pump petcock per instructions under “Adjustable Blowdown” in Section 9.

MAINTENANCE

Sanitizing Procedure

1. After pumping machine down, set “Clean/Off/Ice” selector switch (SS) to the “Off” position.
2. Remove ice from storage area.
3. Shut off water supply and drain water tank (7) by opening drain valve (39). Remove any loose sediment from tank.
4. In a clean container, mix 15 gallons of warm water (90°F–115°F / 32°C–46°C) and 24 ounces of Nu-Calgon® IMS-II Sanitizing Concentrate or equivalent. Note: Concentration should be 200-ppm active sanitizing solution. (Nu-Calgon® IMS-II: 1.6 ounces of sanitizer per 1 gallon of water = 200 ppm). Note: Tank capacity = 14.5 gallons
5. Close drain valve (39) and fill water tank with sanitizing solution. Close the petcock (adjustable blow down) on the water pump.
6. To run the pump only, set the selector switch (SS) to the “Clean” position and press “Start” button to circulate the sanitizing solution.
7. Mix an additional 5 gallons of warm water (90°F–115°F / 32°C–46°C) and 8 ounces of Nu-Calgon® IMS-II Sanitizing Concentrate or equivalent in the clean container. Note: Concentration should be 200-ppm active sanitizing solution. (Nu-Calgon® IMS-II: 1.6 ounces of sanitizer per 1 gallon of water = 200 ppm.)
8. Submerge a clean sponge in the sanitizing solution and wipe all inside surfaces of water box and water box cover, including the makeup water float valve.
9. With the water pump running, add the additional 5 gallons of sanitizing solution to the water tank. Install water box cover on water tank and allow sanitizing solution to circulate for at least 20 minutes.
10. While circulating sanitizing solution, open petcock valve (adjustable blow down) and allow solution to flow down the drain. With petcock valve open, allow water to circulate for a minimum of 3 minutes.
11. Press “Stop” button to stop pump, then drain and flush water tank with fresh water. Open water supply to machine.
12. To sanitize inside the ice storage area, flood the area with sanitizing solution, making sure to wet all surfaces completely for at least 60 seconds. Note: Concentration should be 200-ppm active sanitizing solution. (Nu-Calgon® IMS-II: 1.6 ounces of sanitizer per 1 gallon of water = 200 ppm).
13. Drain, flush tank and refill with fresh water.

Return machine to ice making operation

1. Make sure the water tank drain valve is closed, and the “Selector” switch is in the “Off” position.
2. Turn on the water supply and refill tank with clean water.
3. Manually open the thaw gas solenoid valve “D-valve” (18), by running the stem in. This will allow the pressure to rise in the evaporator and allow the machine to operate. After approximately 1 minute, put “D-valve” back into the automatic position.
4. When tank is full, turn the selector button to the “Ice” position and push the “Start” button for immediate start-up in the ice production mode.
5. Make use the adjustable blow down petcock is adjusted properly.

NOTE: The petcock should be adjusted to the minimum rate required to maintain production of clear ice. (Should be no more than 1 gallon/5 minutes)

Water Distributors. The water distributors are located under the freezer cover at the top of the freezer. These distributors may require occasional or periodic cleaning to remove solids and foreign particles accumulated from the make-up water. The frequency of this cleaning operation will depend on the characteristics of the water supply. The cleaning operation is needed when the inside diameter of a large proportion of the ice becomes irregular (due to channeling of water), or if some of the ice is opaque, or if there is a noticeable decrease in ice capacity.

Size Ice	Number of Tubes	Vogt Part #		
		Water Distributor	Freezer Cover	Freezer Cover Gasket
1"	156	12B2185N11	1BA2145C03	12A2600G15
1 1/4"	102	12B2185N21		
1 1/2"	72	12B2185N31		

TABLE 7-1
Number of Water Distributors Per Tube Size

To clean distributors, stop the unit and remove the freezer cover on top of the freezer. The water distributors (one in each tube) may then be removed with pliers for cleaning. Use pliers on the distributor's top part with a twisting upward motion. Use care when removing distributors to avoid distorting orifice holes or the body of the distributor. The distributors can be soaked in ice machine cleaner to remove mineral buildup. Rinse distributors thoroughly before reinstalling and tap lightly with a rubber mallet to seat them in the freezer tubes.

Tube Size	1"	1 1/4"	1 1/2"
Hole Size	1/16"-1/8" Avg.	1/8"-3/16" Avg.	1/4"-3/8" Avg.

TABLE 7-2
Average Hole Size In Tube-Ice®

Water Tank. The production of opaque ice can indicate that the water in the water tank contains a concentrated amount of solids or salts. Remove cover plate. Open drain valve (28). Clean tank thoroughly by flushing out with a hose and scrubbing with a stiff brush. It may be necessary to completely remove the water tank in order clean all surfaces. After cleaning, close drain (reinstall tank if necessary) and fill the water tank with fresh water. When restarting the machine, be sure that the water pump is circulating water. It is possible that air may have collected in the pump impeller housing and the pump may have to be stopped and started several times to expel the air.

Freezer Cover. A clear polycarbonate freezer cover is provided for visual inspection of the water box and water distributors located at the top of the freezer. The cover should be removed and cleaned if it becomes coated with deposits. Generally, if the freezer cover is coated with solids this is a prime indicator that the other areas (i.e. water tank and distributors) also require cleaning.

MAINTENANCE

Water Cooled Condensers

Checking Operation. How often condensers need cleaning depends on so many variables that it is impossible to recommend a schedule. Some will seldom need cleaning, others perhaps need cleaning once a year. In rare cases, cleaning is required several times a year.

Proper operation of cooling towers will increase the interval between cleaning considerably. The tower overflow rate should be checked frequently. If a tower is operated with insufficient overflow, nominal 1-1/2 to 3 GPH bleed depending on water quality, the resulting mineral concentration in the water can cause rapid and heavy fouling inside the condenser tubes, requiring excessively frequent cleaning. Also, these conditions often lead to severe corrosion.

Chemical additives, including those to stop algae and related growths, should be obtained only from a reputable, established supplier, and used specifically according to directions. Excessive treatment of the water can cause more harm than good: and the condensers, pumps, piping, and the towers themselves may be damaged.

It is advisable to double check the system to make sure that fouling is actually causing the trouble. High head pressure alone does not mean a fouled condenser.

The following possibilities should always be checked before cleaning is undertaken:

1. Non-condensables in system or faulty head pressure gauge? Check standby pressures against refrigerant tables.
2. Incorrectly set or defective water regulator valve? Check its setting and operation.
3. Partly closed compressor discharge service valve? Check its setting. Stem should be backseated.
4. High water temperatures entering condenser? Check tower fan and system.

After the above possibilities have been eliminated, determine the temperature difference between the water leaving the condenser and the refrigerant condensing temperature (saturation temperature, from pressure-temperature chart, corresponding to head pressure). If this difference is more than 10°F, cleaning is indicated because this difference indicates a good heat exchange is not being made. If this difference is less than 8°F, something other than a fouled condenser may be causing the high head pressure. In normal operation, this difference will stay between 5°F and 10°F regardless of water inlet temperature when the water flow is regulated by a pressure operated water valve. If this difference is less than 5°F, restricted water flow or a low supply pressure is indicated. A restriction can occur with foreign matter in the condenser, but it is likely to be somewhere else in the system.

Draining. Draining of water cooled condensers is recommended in preparation for the winter cold where units may be left exposed to ambient temperatures below 32°F. Despite the fact that a condenser may have a vent and drain fittings, the opening of these fittings is not sufficient for a natural gravity flow. Water will be retained in a tube due to (1) surface tension and (2) the normal curvature between tube supports. Experience has shown that as much as 20% of the water in the condenser can be retained. To break the surface tension on the tubes and to drain all tubes completely, it is necessary to actually tilt the condenser a minimum of 5 degrees. Whether water left in the tubes will cause damage during a freeze-up will be dependent upon how quickly the freeze occurs and the location of the water inside the condenser. In the field it is recommended that the tubes be blown out individually with air. Alternatively, a minimum of 25% ethylene glycol in the system will also prevent a freeze, which can rupture the tubes.

Chemical Cleaning. Vogt Ice, LLC makes no recommendation for any particular chemical repair. The same chemical may not be effective for all situations.

! CAUTION !
The following directions and precautions should be observed when cleaning is undertaken. The warranty on condensers is void if they are damaged by improper cleaning tools or methods. If harsh chemicals are used, be sure to follow the manufacturer's recommendations regarding safety in handling those solutions.
! CAUTION !

- a) Use only preparations from an established, reliable source.
- b) Follow directions exactly, particularly regarding amounts to use, and flushing or neutralizing procedure after cleaning.
- c) Close the water supply stop valve. Remove the condenser water regulating valve (41).
- d) Circulate the solution through the condenser until it is considered clean.
- e) Flush the condenser according to directions.
- f) Install the water regulating valve and connecting piping.
Open the water supply stop valve and check for leaks.

Mechanical cleaning.

Part I.

- a) Close the stop valve in the water supply line.
- b) Drain the water from the condenser.
- c) Remove water regulating valve (41) and attached piping to the condenser.
- d) Remove the cover plate on the side of the frame to expose the condenser end plate.
- e) Remove the nuts, water plates, and gaskets from both ends of the condenser. If the gasket does not lift off with the end plate, do not try to pry it off. The seal surface may be damaged, which would cause a water leak. To free a sticking gasket, replace the water plate and tap it on the outside face with a mallet or a block of wood. After a few taps, the gasket will spring free and will then slip off with the water end plate.
- f) Gaskets need only be rinsed in running water: rust, scale or dirt will not stick to gasket material. A rag or soft brush is all that is required to remove any foreign matter.

Part II.

The inside of the water end plates and the outer tube sheet surfaces should be cleaned only with clear water and a rag or a soft bristle brush. A worn paint brush is excellent.

These surfaces have been coated with a special material which will give years of protection against corrosion unless damaged. Never use a wire brush or a strong caustic on these surfaces.

MAINTENANCE

Flush condenser tubes clear with air, water, or a piece of rag on a stick or wire. In many cases this is all that is required. If the inside surfaces are smooth, even though discolored, further cleaning is not necessary. It is useless to try and get a bright copper surface on the inside of the tubes. They will discolor almost immediately in service and the condenser has been designed with an adequate reserve for moderate fouling on these surfaces.

If, however, a rough coating remains inside the tubes after flushing and wiping, further cleaning is desirable. The color of this coating varies with water conditions, but roughness indicates cleaning tools should be used.

Any type tool to be considered should be tried first on a piece of copper tubing held in a vise or flare block. Nylon, brass, or copper brushes are recommended. If any flakes of copper appear or if score marks are made inside the tube, the tool should not be used. Never use anything with sharp or rigid edges, which could cut into the copper tubing.

Lubrication

Compressor. When starting and charging the unit, the oil sight glass (33) in the crankcase of the compressor should be watched carefully for the first hour to make certain the proper lubrication is being maintained. The oil may become low in the crankcase on an initial start-up if electrical current has been interrupted to the machine, thus de-energizing the compressor crankcase heater.

Before starting the machine again, the heater should be energized for a time period of at least two hours to evaporate refrigerant that may have condensed in the crankcase during the shutdown period. If the level is low after start-up, it should begin to return after a short period of operation.

The oil level should be checked frequently, particularly during the start-up operation, to see that a sufficient amount of oil remains in the crankcase. While it is important to observe the oil splash during operation, the true level can be obtained only when the compressor is stopped. With the compressor idle, the oil level should be at a height of 1/4 to 1/2 of the sight glass but never out of sight above it.

The machine is properly charged with oil for the test operation, but it may be necessary to add some oil when or if new refrigerant is added to the system. Generally, air-cooled machines will require additional refrigerant and oil to compensate for long piping runs to the condenser.

Refrigerant	Recommended Lubricants	Type of Lubricant
HCFC-22 (R-22)	Suniso 3GS, Texaco WF32, Calumet RO15 (Witco)	Mineral Oil
R-404A	Mobil EAL ARCTIC 22 CC, ICI (Virginia KMP) Emkarate RL 32S	Polyol Ester Oil

TABLE 7-3
Recommended Lubricants

Compressor	HP	Oil Charge (oz)
6DYN & 6DY3	21	140
6DNN & 6DN3	24	140

TABLE 7-4
Compressor Oil Capacity

An oil pump should be used to force any oil that may be required into the system. Oil may be added to the compressor through the oil separator oil return line fitting on the compressor or the compressor suction service valve. The compressor suction service valve should be “back seated” to shut off pressure to the gauge port when connecting the oil pump. Air should be purged from the oil pump discharge line by forcing some oil through the line before tightening the charging connection.

Cutter Gear Reducer. The oil level for the gear reducer should be checked if there is evidence of a leak. It should be level with the plugged opening in the side of the gear housing. Use Mobile 600W cylinder oil or equal. Change oil once a year.

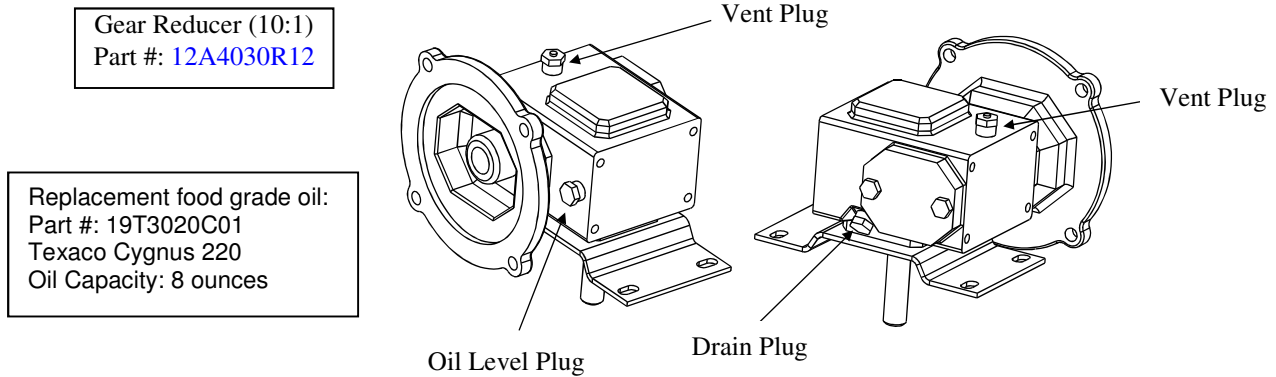

Note: Ventless gear reducer used after August 2010

FIGURE 7-2
Gear Reducer

MAINTENANCE

Preventive Maintenance A careful inspection of the Tube-Ice[®] machines refrigeration system for leaks and correct operational functions at time of installation will start its long satisfactory life of service. In order to insure this degree of dependability, a systematic maintenance program is recommended. Therefore, the following schedule is suggested as a minimum.

A. Daily

1. Check operating pressures (suction, discharge, oil).
2. Check ice quality.
3. Check "ice out" time (maintain 30 seconds of continued harvest after last ice is out).
4. Check compressor oil level.
5. Check refrigerant operation level.
6. Check frost pattern on freezer shell and oil trap.
7. Check make-up water float valve adjustment.

B. Weekly (in addition to daily checks)

1. Check for leaks after 400 hours or four weeks of operation

C. Monthly (in addition to weekly checks)

1. Check calibration and operation of all controls (high & low press switches, oil press switch, etc.)
2. Check cooling tower spray nozzles and pump suction screen for scaling and algae (consult water treatment suppliers for corrective measures).
3. Check water distributors in freezer for scale accumulation.
4. Check water tank for solids to be removed.
5. Check all motor drive units (compressor, cutter and pump motors, cooling tower fan, and pump, etc) for abnormal noise and/or vibrations.
6. Check oil level in gear reducer.
7. Check one complete freeze/thaw cycle, record data and compare with production check of Registration/Start-up Report.

D. Yearly (in addition to weekly and monthly)

1. Check entire system for leaks.
2. Drain water from condenser and cooling tower and check condenser tubes. Check closely for damage by corrosion or scale.
3. Remove all rust from all equipment, clean, and paint.
4. Check all motors for shaft wear and end play.
5. Check operation and general condition of all electrical controls, relays, motor starters, and solenoid valves.
6. Check freezing time, ice release time, and ice out time.
7. Change oil in gear reducer box once a year.

PRESSURE RELIEF VALVES MUST BE REPLACED AFTER 5 YEARS OF SERVICE.

**BEFORE REPLACING RELIEF VALVE, REVIEW REQUIREMENTS PER CURRENT
LOCAL AND NATIONAL CODE.**

NOTE: IF RELIEF VALVE DISCHARGES, VALVE MUST BE REPLACED BECAUSE SETTING OR SEAT
TIGHTNESS MAY BE ALTERED.

CONTACT VOGT ICE PARTS DEPARTMENT FOR REPLACEMENT VALVES.
PHONE: 502-635-3000

For The Manager Who Depends Upon This Machine For Efficient Operation.

“Preventive Maintenance” simply means that you or a delegated employee makes a daily visual check of your Tube-Ice[®] machine. Here is what to look for and why:

Daily checklist:

1. Is the machine running or is the bin full
2. Bin doors kept closed
3. Thermostat bulb in bracket
4. Ice quality (clarity and uniformity)
5. Does all ice discharge during harvest
6. Cleanliness
7. Unusual noises

Why? When you make these simple observations on a daily basis, you insure the smooth production of ice for your facility. When you are aware of the proper operating conditions and observe them on a daily basis, changes in these conditions can alert you to changes in the operation of the machine which may require maintenance--long before a service situation arises.

“An ounce of prevention is worth a pound of cure!”

MAINTENANCE

Note To Manager or Owner:

This page is a complete Preventive Maintenance Schedule that should be performed each 90 days. The Preventive Maintenance page may be copied and given to your service person. It should be signed, dated, and returned to you for permanent record.

Preventive Maintenance Program

This form can be removed and duplicated for keeping accurate records.

Model # _____ Serial # _____ Date _____

Customer/Address _____

Mgr. Name _____ Service Tech Name _____

The following service performed and checked:

- _____ Last maintenance performed (approx. date)
- _____ Scale condition of water tank & tubes (good - fair - poor)
- _____ All drains freely draining (water tank, drip pan, ice bin)
- _____ Water distributors cleaned
- _____ Ice machine cleaner circulated through system
- _____ Condenser clean (if applicable)
- _____ Voltage at machine (actual reading) _____, _____, _____
- _____ Compressor amps (halfway through the freeze cycle) _____, _____, _____
- _____ Cutter motor amps (cutting ice) _____, _____, _____
- _____ Water pump amps _____, _____, _____
- _____ AC condenser motor amps (if applicable) _____, _____, _____
- _____ Crankcase heater heating
- _____ Refrigerant leak (okay - high - low)
- _____ Leak checked system _____ leaks found & repaired
- _____ Compressor oil level (i.e., 1/4 - 1/2 - 3/4 - low - high)
- _____ Gear reducer oil (okay - low)
- _____ PSIG, low pressure switch set @ _____
- _____ PSIG, high pressure switch set @ _____
- _____ Bin stat(s) installed and operating properly
- _____ Make-up water float valve adjusted okay
- _____ Adjustable blowdown adjusted for clear ice
- CYL _____ CRU _____ Suction PSIG at end of freeze
- CYL _____/_____ CRU _____/_____ Suction PSIG during harvest (high/low)
- CYL _____ CRU _____ Discharge PSIG at end of freeze
- _____ °F/°C at machine _____ °F/°C outside ambient (at condenser if applicable)
- _____ °F/°C make-up water temperature
- _____ Freeze cycle time (minutes)
- _____ Harvest cycle time (minutes)
- _____ First ice out (seconds)
- _____ All ice out (seconds)
- _____ Pounds of ice per cycle
- Capacity check: $\frac{\text{ice weight per cycle}}{\text{total cycle time (min)}} \times 1440 = \text{_____ lbs. (24 hr. capacity)}$

Remarks: _____

8. Troubleshooting

NOTE: With the exception of bin control, anytime the machine stops, it must be manually re-started by pushing the "Start" push-button. If it stopped while in a freeze cycle, it will then start in a thawing cycle.

Always check the machine thoroughly after remedying the problem to prevent the same cause from reoccurring.

<u>Symptom</u>	<u>Page</u>
Machine Won't Run	8-2 & 8-3
Freeze-up Due To Extended Freeze Period	8-4
Freeze-up Due To Ice Failing To Discharge	8-5
Poor Ice Quality	8-6
Low Ice Capacity	8-7
Low Compressor Oil Level	8-8
High Head Pressure (Water Cooled Machines)	8-9
High Head Pressure (Air-Cooled Machines)	8-10

TROUBLESHOOTING

SYMPTOM: Machine won't run.

POSSIBLE CAUSE	POSSIBLE REMEDY
Power failure ++ Intermittent power interruption	Check electrical fused disconnect or circuit breaker supplying power to the machine. If power has been off, make sure the compressor crankcase heater is energized, the crankcase is warm, and there is no liquid refrigerant in the crankcase prior to running the machine. Push the "Start" button which will initiate startup in a thawing cycle.
Compressor motor overload (CMS-OL) trips. Note: Used on 4D & 6D compressors without Coresense. All 3D compressor have Internal Line Break for overcurrent protection. Coresense on 4D & 6D compressors combines overcurrent & oil pressure protection. (after March 2011)	Check for a loose connection on all motor contactor and compressor terminals, which could have caused excessive amp draw. Check amperage, power supply, and head pressure. Excessive temperature may be caused by gas leakage between suction and discharge port of the compressor. Check for broken cylinder head gasket or valve assemblies. Replace broken or defective parts. Restart the machine and check motor amps and temperature of compressor body. Note: Switch on 4D & 6D compressors without Coresense and 3D compressors (with line break protection) will reset automatically after the motor has cooled sufficiently.
Compressor cylinder head temperature switch trips.	The thermal switch will reset automatically after the motor has cooled sufficiently. Excessive temperature may be caused by gas leakage between suction and discharge port of the compressor. Check for broken cylinder head gasket or valve assemblies. Replace broken or defective parts. Restart the machine and check motor amps and temperature of compressor body.
3.0 amp circuit breaker (CB) in the control panel tripped.	Check compressor crankcase heater, coils of relays, contactors, starters, solenoid valves, and thawing timer for a ground. Repair or replace any defective part, and replace fuse. Make sure there is no liquid refrigerant in the compressor crankcase prior to re-starting the machine.
High/Low safety pressure switch tripped.	If the machine stops by low pressure cut-out, the switch will reset automatically when the pressure raises to the " cut-in " setting. If it stops by high pressure cut-out, the switch will have to be manually reset after the pressure drops below the " cut-in " setting. Check switch settings and push the "Start" push button to start the machine in a thawing cycle. Check the head pressure during the next freeze cycle. See FIGURE 9-4, Section 9, (High/Low Pressure Switch).

SYMPTOM: Machine won't run (CONT.)

POSSIBLE CAUSE	POSSIBLE REMEDY
Low oil pressure switch tripped.	If the machine stops by low oil pressure cut-out, the switch will have to be manually reset. Check the crankcase oil level. Restart the machine by pushing the "Start" push button. Check the oil level and net oil pressure (net oil pressure = pressure reading at the oil pump end bearing housing minus suction pressure). The oil level should be 1/4 - 3/4 level in the glass. If above 3/4, drain some oil out. See page 9-9, Section 9 (Oil Pressure Sensor).
Cutter motor overload tripped.	Check and clear the cutter area and ice discharge path of all ice. Check voltage and overload range adjustment against motor rating. Reset the switch and restart the machine by the "START" push button. Check the cutter operation and motor amp draw. If tripping repeats, but ice is not jammed, check the cutter bearing for wear, the gear reducer for resistance, and the motor for defect or single phasing.
Pump motor overload tripped.	Check voltage and overload range adjustment against motor rating. Reset the switch, set the "Ice/Clean" switch to the "Clean" position and restart the machine by the "Start" push button. Check the pump operation and motor amps. If tripping repeats, check for a defective overload, defective motor, or single phasing.
Bin thermostat or bin level control stops machine.	Adjust or replace the bin stat or level control. Make sure bin stat bulb or level control is located properly in the bin. See FIGURE 3-9, Section 3 (Bin Thermostat).
Defective control panel component such as, PF, BC, CMS PB1, CB, T, Etc.	See FIGURE 6-3, Section 6 (Wiring Schematic). Check for open circuit. Refer to FIGURE 6-2, Section 6 (Control Panel) to identify parts. Replace defective part, restart machine and check power supply and current draw.

TROUBLESHOOTING

SYMPTOM: Freeze-up due to extended freeze period.

POSSIBLE CAUSE	POSSIBLE REMEDY
Freezer pressure switch setting too low.	Adjust freezer pressure switch, or replace if defective. See FIGURE 9-3, Section 9.
Water tank drain valve (39) open or leaking, or make-up water float valve (12) stuck open.	Close valve, repair, or replace as necessary.
Thawing gas solenoid valve (18) leaking through during the freeze cycle.	Check the manual opening stem to make sure it is in the automatic position (stem screwed out). Check for leakage through the valve by sound and temperature difference. Close the stop valve (90) at the receiver to confirm suspicion of leakage. Repair or replace the valve as needed.
Float switch stuck or failed in the closed position.	Check to make sure the float switch is opening and closing.
Liquid feed, "A1" valve stuck open	Check to make sure the "A1" Valve is not in the manual open position. Disassemble valve and inspect for debris which could hold the valve open.

SYMPTOM: Freeze-up due to ice failing to discharge.

POSSIBLE CAUSE	POSSIBLE REMEDY
Insufficient heat for thawing because of low condensing pressure, non-condensables (usually air) in system, low refrigerant charge, or thaw gas pressure switch adjusted too low.	The head pressure should be maintained at approximately 210 PSIG for R-22 or 250 PSIG for R404a, which relates to 105F (37.8C). This is done by a water regulating valve (water-cooled units) FIGURE 9-5A, Section 9, or a Fan cycling switch (air-cooled units) FIGURE 9-5B, Section 9. If non-condensables are present with the refrigerant, the saturated temperature will not relate to the pressure reading at the receiver. The refrigerant level in the receiver should be near the operating mark at the end of a freezing cycle to provide enough volume for harvesting. (1" = approx. 11 lbs. of R22 or R404a).
Thawing time too short.	Check the thaw timer (T) which should be adjusted to allow all the ice to clear the cutter and ice discharge opening with at least 30 seconds to spare.
Cutter or cutter disc does not turn.	Check cutter reducer and drive gear for proper operation and alignment. Check for broken cutter disc or drive pin and replace as necessary.
Ice backs up into cutter or discharge opening, jamming cutter	Ice mushy due to concentration of solids in the water tank. Perform "Cleaning Procedure" and check automatic and adjustable blowdown. If the machine discharges ice into a chute, it should slope at an angle of 30 degrees for cylinder ice, and 45 degrees for crushed ice. Check bin stat or level control to make sure it will stop the machine before ice backs-up into the cutter.
Extended freeze period.	Check freezer pressure switch adjustment, see FIGURE 9-3, Section 9, (Freezer Pressure Switch) and TABLE 11-6, Section 11 (Operating Vitals).
Compressor not unloading.	Check compressor amps during harvest. A noticeable drop in amperage should occur. Check unloader solenoid coil. If coil is okay, replace unloader head assembly.

TROUBLESHOOTING

SYMPTOM: Poor ice quality.

POSSIBLE CAUSE	POSSIBLE REMEDY
Excessive concentration of solids in the water tank, usually indicated by a build-up of mineral deposit on the sides and bottom of the tank.	Perform a cleaning procedure as well as removing the freezer cover and cleaning the water distributors. Adjust continuous blowdown.
Insufficient water supply, indicated by a low level in the tank.	Check water pressure, 30 PSIG is recommended minimum. Check for a water line restriction, partially closed valve, or defective make-up water float valve. Make sure the water tank drain valve is closed.
Water pump rotation wrong direction.	Check rotation in relation with arrow on pump housing, and reverse two wires at the motor if necessary.
Low refrigerant charge.	Check refrigerant level mark on the receiver, and on the painted portion of the gage glass guard. Perform a pumpdown if necessary. Be sure to keep the gage glass cocks closed when finished checking the level.
Insufficient blowdown during harvest	Check for proper operation of the siphon vacuum break valve and restrictions or traps in the water tank drain assembly.

SYMPTOM: Low ice capacity.

POSSIBLE CAUSE	POSSIBLE REMEDY
Low refrigerant charge.	Check for and repair leaks, and add refrigerant.
Restriction in liquid line.	Check for a partially closed valve, or an obstruction at the drier, strainer, solenoid valve, or expansion valve. The liquid line will normally have frost on the downstream side of a restriction, especially as the suction pressure decreases.
Float switch stuck or failed in open position	Make sure the float switch is opening and closing. Make sure the "A1" valve is getting power.
Thawing gas solenoid valve (18) leaking through during the freeze cycle.	Check the manual opening stem to make sure it is in the automatic position (stem screwed out). Check for leakage through the valve by sound and temperature difference. Close the stop valve (90) at the receiver to confirm suspicion of leakage. Repair or replace the valve as needed.
Water distributors at top of freezer may be stopped up.	Remove freezer cover and clean the distributors. See Water Distributors, Section 7.
Inadequate water for ice making.	Check water pressure (30 PSIG minimum recommended). Check for a water restriction in the supply line or at the make-up water float valve.
Make-up water float valve (12) stuck open, adjusted too high, or water tank drain valve (15) open or leaking	Repair, replace or adjust float valve, or close, repair, or replace water tank drain valve.
Controls for regulating freezing and thawing cycles not adjusted properly.	For highest capacity, cylinder ice should have a small hole and crushed ice should be about 3/16" thick. Check the freezer pressure switch and thaw timer for proper adjustment, Section 9.
Excessively high head pressure.	Check water regulating valve or fan control adjustment. Check to make sure the WC or AC condenser is clean. Check refrigerant tables for pressure/temperature relation.
Warm make-up water for ice making.	Capacity of the machine is proportional to ice making water temperature. Warmer water will reduce the ice making capacity. See Section 11, Capacity Table.
Drain valve (12) open.	Close drain valve (12).

TROUBLESHOOTING

SYMPTOM: Low compressor oil level.

POSSIBLE CAUSE	POSSIBLE REMEDY
Oil separator not returning oil.	Check oil separator float and oil return stop valve (70) and line for a restriction. The oil return line should be above ambient temperature most of the time as it returns oil. It may be cooler at the start of a freeze cycle. Repair or replace defective parts.
Repeated short cycling (refrigerant carrying oil out of compressor).	Usually caused by freeze-up, low refrigerant charge, low head pressure, faulty timer, faulty pressure switch or expansion valve clogged. Use process of elimination.
Worn piston rings.	This condition is hard to detect without dismantling the compressor and checking piston ring tolerances. Normally there will be a little puddle of oil laying on top of the piston when the head and valve plate are removed. It is best to replace the compressor.

SYMPTOM: High head pressure. (Water cooled machine)

POSSIBLE CAUSE	POSSIBLE REMEDY
Misadjusted or defective water regulating valve	Adjust or replace the valve. Never adjust the valve stem as far open as it will turn, because it will not close when the head pressure drops.
Insufficient water supply.	Check size of water line and pump output at the condenser. Refer to the specification sheet for water requirements. Check cooling tower sump level and make-up water supply.
Cooling tower needing maintenance.	Check cooling tower fan belt and tighten or replace as needed. Check spray nozzles and sump screen and clean as needed.
Non-condensables (usually air) in system.	Check refrigerant tables for pressure/temperature relation. If non-condensables are present, Perform a total pumpdown, let stand for at least 6 hours, allowing non-condensables to gather in the upper part of the receiver. Evacuate the freezer and attach a recovery unit to the top receiver purge valve (59). Open the valve and recover the vapor for about five minutes. When the freezer is evacuated, open the thaw gas solenoid valve manually for about 15 seconds letting the top vapor in the receiver blow into the freezer. Close the solenoid valve and evacuate the freezer again. Evacuate to 500 microns and restart the machine.
Fouled (dirty) condenser.	Follow the diagnostic procedure outlined in, Section 7, and clean the condenser per instructions under Condenser Cleaning,

TROUBLESHOOTING

SYMPTOM: High head pressure (Air-cooled machine).

POSSIBLE CAUSE	POSSIBLE REMEDY
Condenser fan(s) not running.	Defective motor, fan control switch, fan contactor, or tripped fan motor overload. Replace defective part. Check condenser fan disconnect for thrown switch, or blown fuse. Replace fuse and reset switch. If the condenser is split, check the normally open solenoid valve to make sure it is open, also check the fan sequencing thermostats and fan motor contactors to make sure they are functioning properly. Replace any defective parts.
Dirty condenser causing restricted air flow.	Visually inspect condenser and clean as necessary.
Non-condensables (usually air) in the system.	Follow same procedure as specified for removing non-condensables from Water Cooled machine, except evacuate the air-cooled condenser also.

9. Service Operations

Adjustable Blowdown (for clearer ice) A petcock is installed on the overflow of the water pump to provide means for obtaining blowdown from the water tank during the freezing period. The petcock was set at the factory to discharge enough water during the freeze cycle to produce clear ice. After installation it should be adjusted to the minimum rate required to maintain clear ice and checked after a few days of ice making.

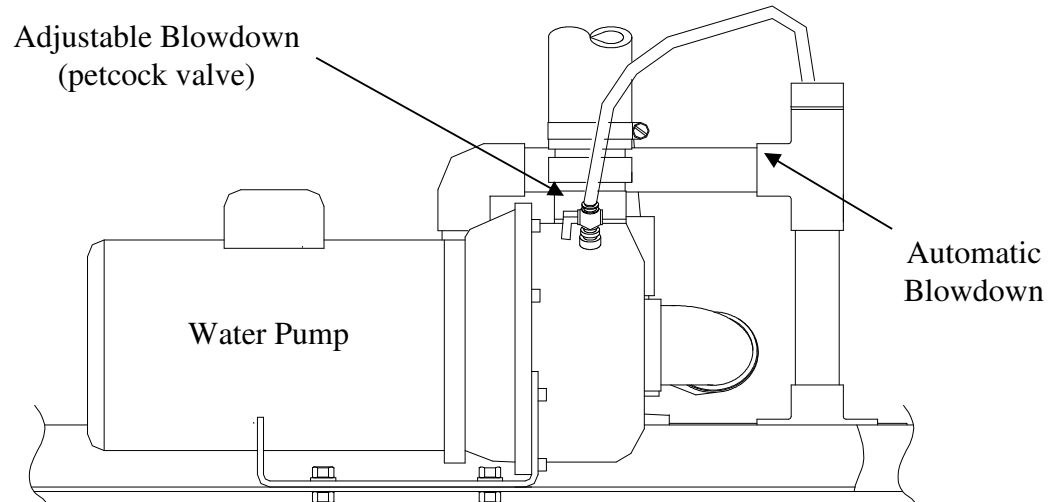

FIGURE 9-1
Water Pump / Blowdown Assembly

Automatic Blowdown (Harvest Cycle) A feature of this machine is the automatic blowdown (40) which is provided to eliminate or reduce the necessity for frequent flushing or cleaning of the water tank (7) and to remove accumulated salts or solids in the water as a result of the freezing action. During the harvest water returning from the freezer raises the tank level and causes an overflow of water, which creates a siphon to remove a fixed amount of water from the tank.

Make-up Water Float Valve (Part No. [12A4200H0402P](#)) The make-up float valve (12) maintains the proper pumping level in the water tank for ice making. The valve should be set to maintain a water level in the water tank during the freezing period, so that there will be a quantity of by-pass or blowdown only during the thaw mode. The water level during the freeze mode should always be below the by-pass piping to prevent excessive waste of cold water, resulting in loss of ice capacity.

If it should become necessary to clean the float valve, close the stop valve in the make-up water line to the machine and remove the float valve. After the valve has been cleaned and reinstalled, check to ascertain if the proper water level is being maintained. After the machine is stopped and the water in the tank seeks its normal level, there should be no water flow through the float valve or drain by-pass.

It is advisable to install a large area strainer in the water supply line to protect the float valve from dirt or solids in the water, which would necessitate frequent cleaning. A strainer of 40 mesh screen is usually satisfactory.

SERVICE OPERATIONS

Float Switch (Part No. [12A7500E22](#)) The float switch is installed on a header assembly that is attached to the freezer shell. Valves are provided for isolation of the float switch assembly if replacement or servicing is necessary. The float switch closes as the level of refrigerant in the freezer rises and opens as the level falls.

The float switch is connected to the liquid feed solenoid valve (“A” valve) coil. This is the solenoid valve directly before the hand expansion valve. Therefore when the refrigerant level in the freezer drops, the float switch opens, thereby de-energizing the normally open liquid feed solenoid until sufficient level has been reached to close the float switch. The float switch has a fixed 1/2” differential.

The float switch is installed at the correct height at the factory and should not need to be adjusted. The float switch is installed at the position that provides highest capacity. The correct height will produce compressor superheat which climbs throughout the freeze cycle to a minimum of 30° F.

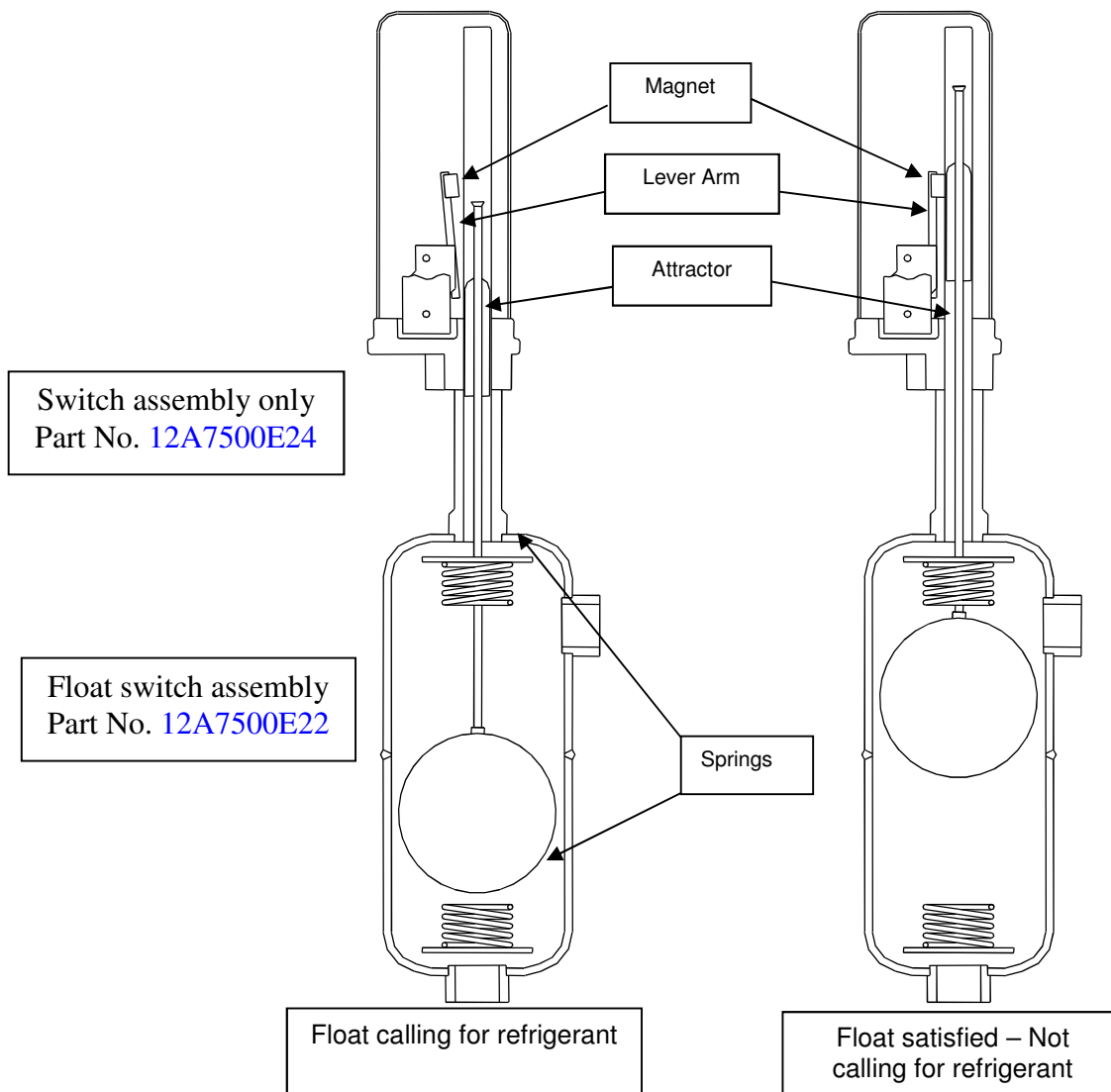
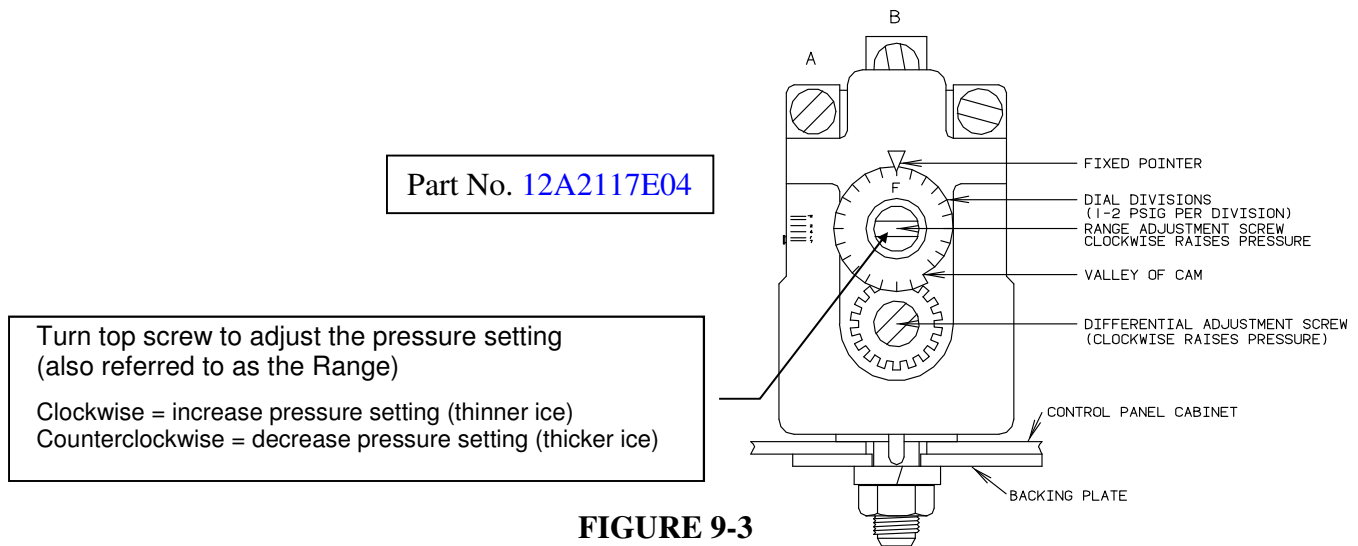

FIGURE 9-2
Hansen Refrigerant Float Switch

Hand Expansion Valve (Part No. [12A4200C0605](#)) The hand expansion valve is located after the liquid feed solenoid valve (“A1” Valve). This valve should be set at a point where the float switch is open for a length of time approximately equal to the time it is closed. The factory setting is about 2 turns from full open.

Freezer Pressure Switch (Part No. [12A2117E04](#)) The freezer pressure switch (FPS), located inside the control panel, controls the freezing time period for the production of cylinder or crushed ice.

This switch was set at the factory to produce ice of recommended thickness. Look at the “Certificate of Test” which was provided with the machine for a sample set of pressure readings with corresponding time periods and water temperatures. Also see TABLE 11-6, Operating Vitals for typical settings. Do not make adjustments until several ice discharging cycles have been completed.



The following procedure is recommended for initially setting a freezer pressure switch that has **not** been previously adjusted (See FIGURE 9-2):

1. Turn the bottom screw (differential) approximately 1/2 turn to the Left (counter clockwise). The pointer arrow, which is at the top middle of the switch, will be at the “F” setting.
2. Turn the top screw (range adjustment) approximately 4 1/2 turns to the Left (counter clockwise). The pointer on the range setting will be between 40 psi and 50 psi.
3. After the machine is running, the range adjustment (top screw) will have to be fine-tuned to get the proper ice thickness. (Clockwise = Thinner Ice) (Counter Clockwise = Thicker Ice)

The freezing time can be such that a small percentage of the ice is frozen solid. If so, some ice from the top and bottom of the freezer should have a small hole in the center to insure that the freezing time has not been extended to where a loss in capacity would result.

It is preferable that the freezing cycle be such that a small diameter hole remains in the center of the ice cylinder. (1/16” diameter for 7/8” diameter ice, 1/8” diameter for 1 1/8” diameter ice) This insures that the freezing cycle is not extended unnecessarily and eliminates a possible opaque core in the center of the ice.

SERVICE OPERATIONS

Capillary Bypass The capillary bypass is located directly following the “A2” solenoid. The “A2” solenoid should be energized (Open) during the entire freeze cycle. The function of the capillary bypass is to meter a set minimum amount of refrigerant to the freezer during the freeze cycle, thereby reducing cycling of the float switch.

High-Low Pressure Switch The high-low pressure switch (HPS) (FIGURE 9-4) is a two pole dual function switch. Located in the machine mounted to the frame near the compressor. It protects the machine from possible damage due to abnormal pressure during operation.

! CAUTION !
When this switch causes the machine to stop, the cause should be identified and corrected before resuming normal operation.
! CAUTION !

The **LOW** pressure cut-in should be set at 40 psig and the cutout set at 20 psig for R-22

The **LOW** pressure cut-in should be set at 52 psig and the cutout set at 28 psig for R-404a.

NOTE: After tripping at the cutout setting, the switch will reset automatically when the pressure rises to the cut-in setting.

The **HIGH** pressure cutout should be set at 300 psig for R-22 and 350 psig for R-404a. After tripping, reset the switch manually.

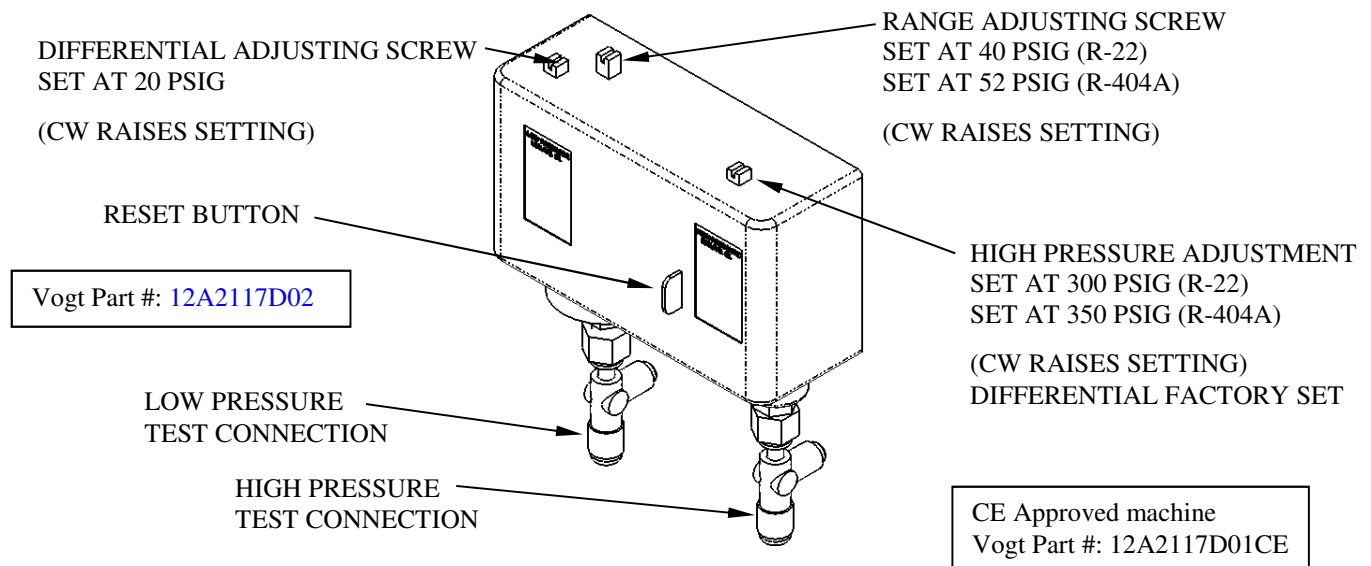

FIGURE 9-4
High-Low Pressure Switch

If it becomes necessary to install a new high/low pressure switch, the following procedure is recommended for its adjustment:

Turn the adjusting screws clockwise to raise the pressure setting. Turn counter-clockwise to lower the setting. Adjust the switch to the indicated pressure settings and test with an accurate gage to be sure the switch functions properly before installation.

Head Pressure The head pressure should be maintained at 190-210 psig for R-22 and 230-250 psig for R-404a during the freeze cycle. This pressure can be checked at the test connection in the high pressure line near the high-low pressure switch.

Water-Cooled Units A water regulating valve (FIGURE 9-5A) located in the condenser water inlet line is used to control the water flow through the condenser. This valve should be adjusted to maintain a head pressure of 200 psig for R-22 and 235 psig for R-404a. Increasing the water flow lowers the head pressure and decreasing the water flow raises the head pressure. The valve is adjusted during the factory test. The valve stem should not be opened as far as it will go or the valve will not close fully when the head pressure drops below its setting.

Air-Cooled Units The condenser fan switch mounted to the frame (lower right side) (FIGURE 9-5B) (CPS) is used to regulate the head pressure. This is an adjustable pressure switch located on the right-hand front of machine. It controls the operation of the condenser fan motor(s) through a contactor (FC) (FIGURE 6-2) located in the control panel. The switch is set to cycle the fan motor(s) “On” at 210 psig and “Off” at 190 psig for R-22 and “On” at 250 psig and “Off” at 230 psig for R-404a. Higher settings may be necessary for 0°F and below ambient conditions to assure there is enough warm gas for ice harvesting.

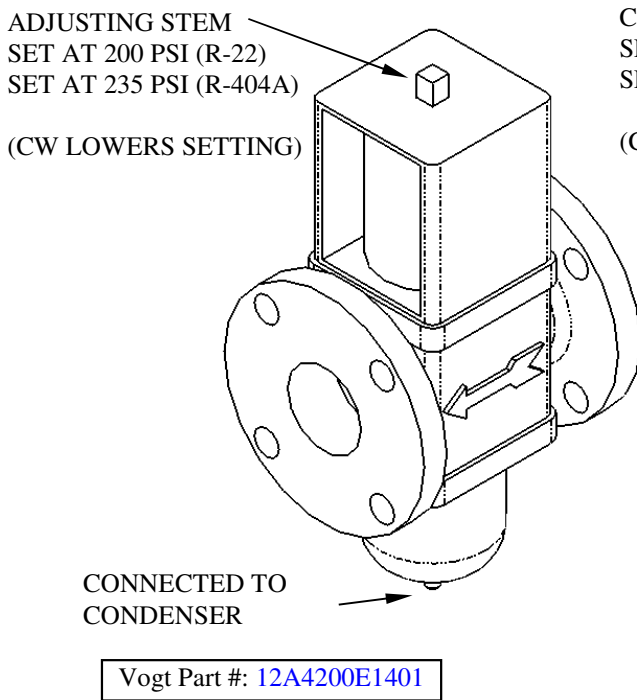

FIGURE 9-5A
Water Regulating Valve

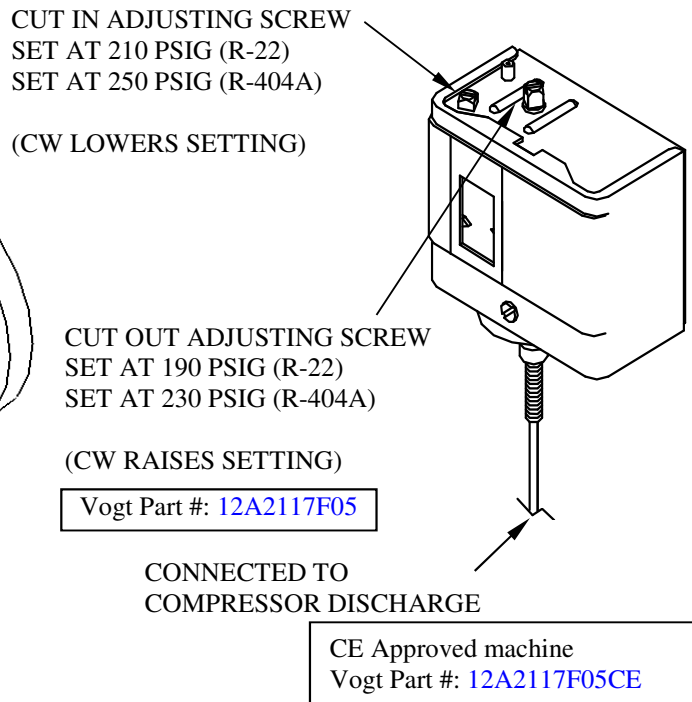

FIGURE 9-5B
Condenser Fan Switch

Condenser Cleaning See “Water Cooled Condensers”, “Maintenance”, Section 7.

Air-Cooled Condenser Visual inspection will indicate if dirt is accumulating and clogging the fin face of the condenser. A vacuum cleaner, compressed air or a brush may be used to remove an accumulation of dirt from the fin section of the condenser.

SERVICE OPERATIONS

Compressor Motor Protector, Electronic Copeland compressors using solid state protection have PTC (Positive Temperature Coefficient) internal sensors with an avalanching resistance in the event of high temperatures. The sensors are calibrated for proper motor protection.

The solid state sensor protectors provide excellent protection against high motor temperatures resulting from locked rotor, loss of charge, or motor overload. The combination of low voltage sensing and time delay provide positive protection against low voltage conditions which can occur in the pilot circuit in the event of a single phase condition on a three phase circuit.

The low voltage protection feature removes the compressor from the line in the event of low voltage ("brown-out") conditions. The module locks the compressor off the line until the voltage rises to the cut-in setting. The time delay provides a two-minute delay before restarting each time the power circuit is opened. Pressing the start button before the two-minute delay will have no effect. Service and test personnel must be alert to this feature since it is possible in checking the compressor or system, power may be applied, disconnected, and reapplied in less than two minutes. In such case the time delay feature will prevent operation until the time delay has expired and this may be misinterpreted by service personnel as a module malfunction.

The time delay would be energized in the event of a discharge pressure or short circuit protector trip, low voltage, or a break in the power supply to the module. The time delay is not energized on opening of the high or low pressure switches.

There are two major components in the protection system.

1. The protector sensors are mounted internally in the motor windings. The characteristics of the sensor are such that a change in temperature causes a change in the sensor's electrical resistance.
2. The control module is a sealed enclosure containing a relay or triac, transformer, and several electronic components. Leads from the internal motor sensors are connected to the module as shown on the wiring diagrams. While the exact internal circuitry is quite complicated, basically the module senses the change in resistance of the sensors. As the motor temperature rises or falls, the resistance also rises or falls, triggering the action of the control circuit at predetermined opening and closing settings.

Protector modules have two terminals on the module marked "T1-T2" or "L1-L2". These are to be connected to a power source of the proper voltage, normally the line terminals on the compressor motor contactor or the control circuit transformer as required.

The control circuit is to be connected to the two terminals marked "control circuit". When the proper voltage is present and the motor temperature is within limits, the "M1-M2" circuit is closed and the pilot circuit is energized after the two-minute off-cycle time delay. If the motor temperature rises beyond safe limits, the resistance of the motor sensors rises, causing the control circuit to open. The solid state module cannot be repaired in the field, and if the cover is opened or the module physically damaged, the warranty on the module is voided. No attempt should be made to adjust or repair this module, and if it becomes defective, it must be returned intact for replacement.

Electronic Motor Protector / CoreSense Protection High-Potential Testing. The solid state sensors and the electronic components in the solid state module are delicate and can be damaged by exposure to high voltage. Under no circumstances should a high potential test be made at the sensor terminals with the sensor leads connected to the solid state module. Even though the power and pilot circuit leads are not connected, the module can be damaged.

Note: 4D & 6D Compressors manufactured before March 2011 have Electronic Motor Protector.

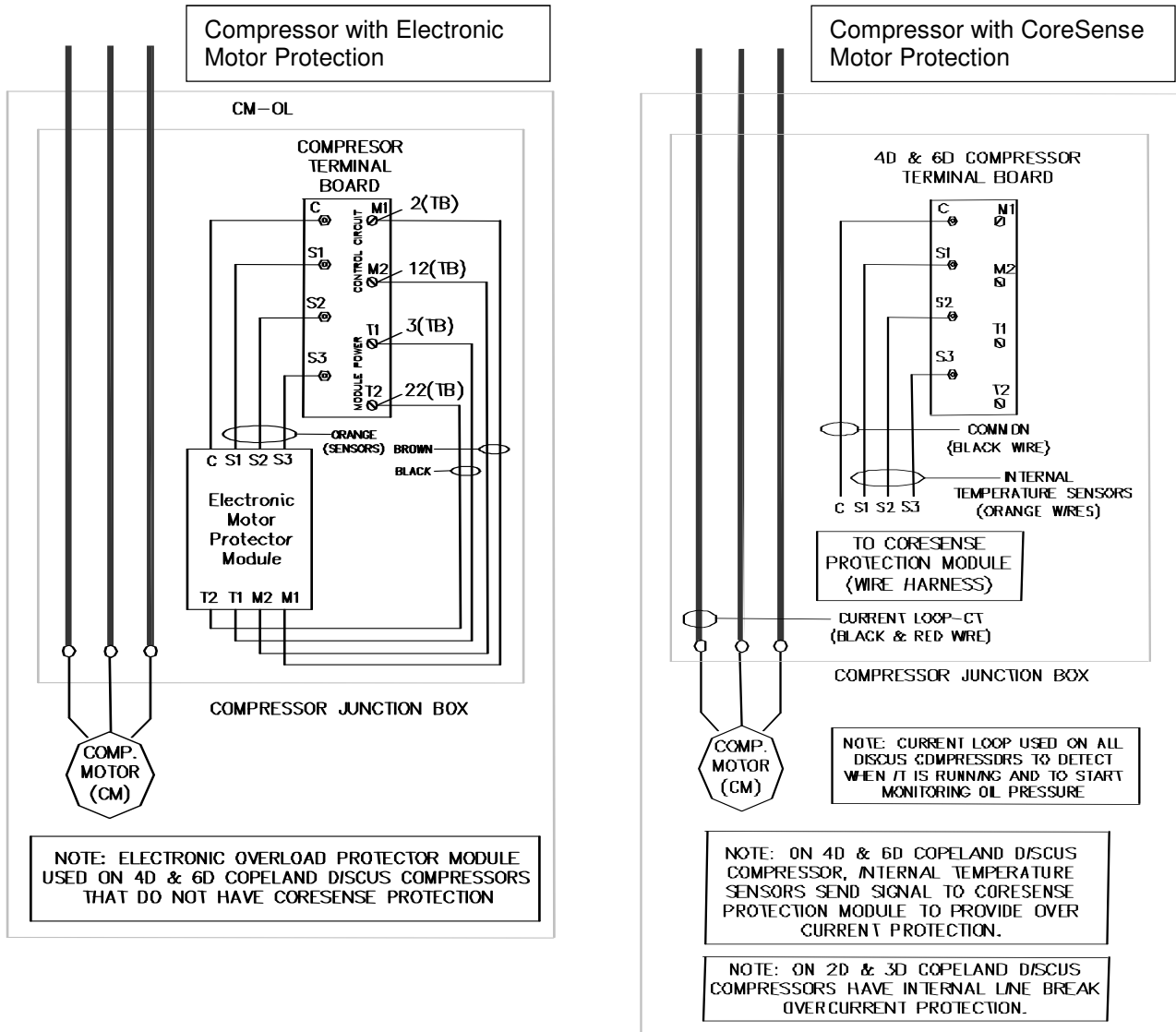

FIGURE 9-6
Compressor Protection Wiring

SERVICE OPERATIONS

Electronic Motor Protector Field Trouble Shooting (4D & 6D compressors before March 2011).
In the event the motor compressor is inoperable or is not operating properly, the solid state control circuit may be checked as follows:

1. If the compressor has been operating and tripped on the protector, allow the compressor to cool for at least one hour before checking. This allows time for the motor to cool and the control circuit to reset.

! WARNING !
Before checking the TI31AA model for its attached wiring sensor, be aware that the sensor terminal "C" has the same voltage as terminal L1.
! WARNING !

2. Disconnect control circuit power to deenergize the module. Connect a jumper wire across the "control circuit" ("M1-M2") terminals on the module control circuit terminal board. This will bypass the "control contact" of the module.
3. Reconnect control circuit power. If the compressor will not operate with the jumper wire installed, then the problem is external to the solid state protection system. If the compressor operates with the module bypassed, but will not operate when the jumper wire is removed, then the control circuit relay or triac in the module is open.
4. If after allowing time for motor cooling, the protector still remains open, the motor sensors may be checked as follows.
 - a) Disconnect control circuit power to deenergize the module. Remove the jumper of Step 2. Remove wiring connections from the sensor and common terminals on the module control circuit terminal board.
 - b) CAUTION: Use Ohmmeter with a maximum of 9 VAC for checking. The sensors are sensitive, easily damaged, and no attempt should be made to check continuity through them with other than an ohmmeter. Any external voltage or current applied to the sensors may cause damage requiring compressor replacement.
 - c) Measure the resistance from each sensor terminal to the common terminal. The resistance should be in the following range:
500 ohms (cold) to 20,000+ ohms (hot. compressor tripped)
 Resistance readings in this range indicate the sensors are good. A resistance approaching zero indicates a short; a resistance approaching infinity indicates an open connection. Proper operation of the control system is dependent on a continuous parallel circuit through all three sensors with no individual resistance reading higher than 10,000 ohms. On initial start-up, and after any module trip due to high temperatures, the resistance of the sensors must be below the module reset point before the module circuit will close. Reset values are 2700-4500 ohms.
5. If the sensors have the proper resistance, and are below 2700 ohms resistance, the compressor will run with the control circuit bypassed, but will not run when connected properly, the solid state module is defective, and must be replaced. The replacement module must be the same voltage and be compatible with the original module on the compressor.

Sentronic Oil Pressure Safety Control (4D & 6D compressors before March 2011).

The Sentronic utilizes a pressure sensor and an electronic control module to precisely measure oil pump differential pressure. The main advantage of Sentronic is the elimination of the traditional capillary tubes, bellows, and pressure connections that mechanical pressure switches require to measure differential oil pressure. These require careful handling and are known to be a source of leaks in refrigeration systems.

A second advantage of Sentronic is in the use of a precise electronic clock for the two-minute time out circuit. Traditional mechanical controls use resistance heaters to provide the time to trip in the event of low oil pressure. 208 volt systems, low ambient temperatures or brown-out type conditions cause the heater output to be reduced, thus increasing the time out period from two minutes to three or four minutes when low oil pressure conditions exist. With the electronic clock, the time out will always be the same.

As a result of the elimination of the capillary tube measuring system and a more precise timing circuit, Sentronic will improve the overall reliability of the refrigeration system. As in the past, all new and replacement Copelametic compressors equipped with oil pumps require the use of a Copeland approved oil pressure safety switch. Failure to use an approved oil pressure safety switch will be considered as misuse of the compressor, and can adversely affect warranty replacement of the compressor should a lubrication connected failure occur.

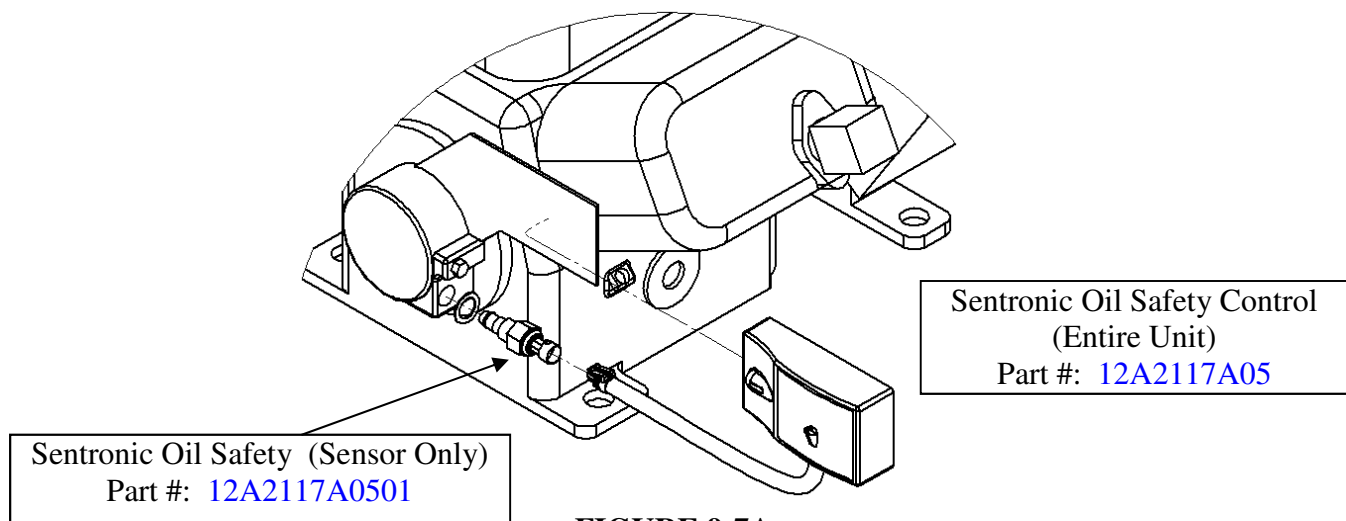

FIGURE 9-7A
Sentronic Oil Pressure Safety Control

Sentronic Sensor (2D, 3D, 4D & 6D compressors before March 2011). The same oil pressure sensor is used for all Sentronic Oil Pressure Controls. It mounts directly into the oil pump. The sensor measures oil pump differential pressure. It has an internal contact that opens on low oil pressure and signals the Sentronic electronic control module to begin time out. The same contact closes when proper oil pressure is present and stops the module time out. Should oil pressure fall below 7-9 PSID for a period of two minutes, the Sentronic module will open the control circuit, using its Normally-Closed (N) contact, and shut the compressor off.

Approximate oil pressure can be measured in the field. Oil pumps are furnished with a Schrader valve mounted on the oil pump discharge port. To measure oil pressure, subtract crankcase pressure from discharge oil pressure. Tripping of the oil pressure safety switch is a warning that the system has been without proper lubrication for too long a time. Repeated trips of the oil pressure safety control are a clear indication that something in the system requires immediate remedial action.

SERVICE OPERATIONS

Sentronic Module (2D, 3D, 4D & 6D compressors before March 2011). The Sentronic has in addition to the (N) contact, used for compressor shutdown, a Normally Open (N.O.) contact that can be used in an alarm circuit. The Single Pole Double Throw (S.P.D.T.) contact of Sentronic can be electrically isolated from the control circuit power supply, and used to control a circuit with a different voltage (See Figure 6-3). The Sentronic has a timing circuit that actually compares the amount of time with good oil pressure to that with insufficient oil pressure. The module memory will shut the compressor down after a period of more than two minutes if the compressor has a "history" of oil pressure fluctuations with more unacceptable than acceptable pressures.

Sentronic also has a memory that retains the compressor oil pressure "history" for up to one minute in the event of a power loss. Sentronic uses a permanent magnet integral with the reset button to reset its output control relay in the event of a trip. When the reset button is depressed, it magnetically pulls the Sentronic relay's armature to its original, reset position. Sentronic needs no voltage present to reset.

CoreSense Protection

Discus compressors manufactured after March 2011 will be supplied with CoreSense Protection. CoreSense replaces the Sentronic Oil Pressure Safety Module on all Discus compressors and the Electronic Motor Protector Module on 4D & 6D compressors. Note: 2D & 3D compressors will continue to have Internal Line Break overload protection.

The oil pressure monitoring portion of the CoreSense will act very similar to the Sentronic Oil Pressure Safety switch. A current transformer (CT) in the compressor junction box determines when the compressor is running and starts monitoring oil pressure. Note: Wire "T1" passes through CT before connecting to compressor terminal.

The CoreSense module has power applied at all times to allow for more detailed fault notification. An LED will flash when a fault occurs. The number of flashes will identify the fault condition.

# of Flashes	Condition
1	Oil Pressure
2	Motor Protection Trip
3	Discharge Temperature (optional add-on)
4	Current Sensor Fault
5	Communication Error

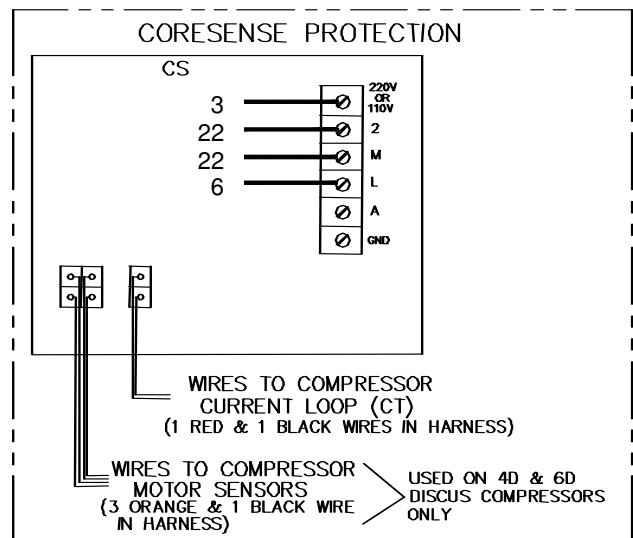
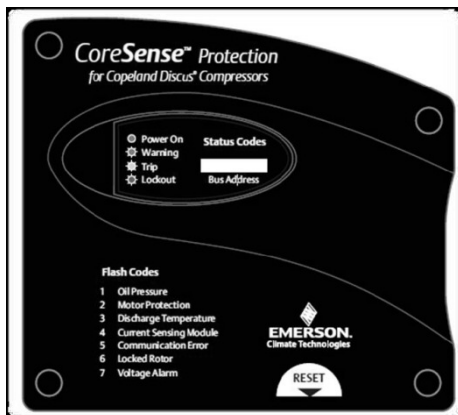
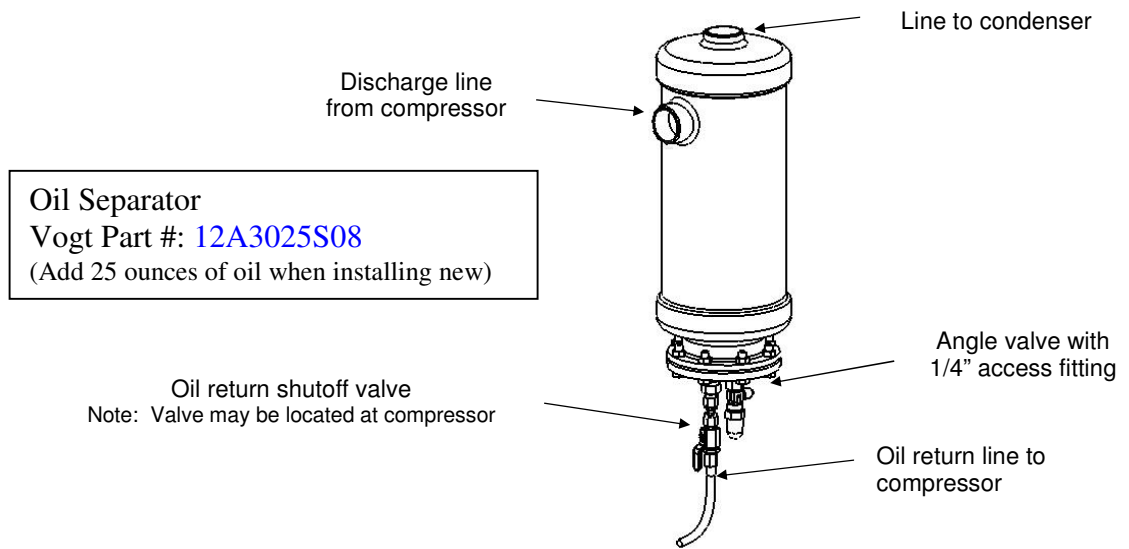

FIGURE 9-7B
CoreSense Protection

Description		Vogt #	Copeland #
Crankcase Heater	100 W (insert type)	12A7509E12	518-0028-01
Oil Pressure safety switch	Sentronic3 Module and Sensor	12A2117A05	585-1076-02
CoreSense Protection	Module and Sensor	12A2117A07	943-0109-00
Oil safety – sensor only	For Sentronic, Sentronic 3 or CoreSense	12A2117A0501	998-0162-00

Oil Separator. A helical oil separator is used to separate the oil from the discharge gas and return it to the compressor. Oil may be drained from the separator through the angle valve located on the bottom of the oil separator. If necessary, the oil return float mechanism may accessed for cleaning or replacement by removing the bottom flange. **Note: Make sure oil is drained and the pressure removed from oil separator before disassembling.**



**FIGURE 9-8
Oil Separator**

Compressor Crankcase Heater-100Watt (Part No. 12A7509E12) When electrical power is supplied to terminals L1, L2 & L3 of the control panel, the crankcase heater is energized when the machine is not operating. It is de-energized when the compressor contactor is energized.

Control Circuit Protection (Part No. 12A7504E1) The electrical control circuit of the machine is protected by a 2 Pole, 3A circuit breaker. If the breaker should open, the machine will immediately stop. Before resetting the breaker, open the disconnect switch to machine and set the “Clean/Off/Ice” selector switch to the “off” position. If the machine was off for an extended time the crankcase heater must be energized for a minimum of two hours before restarting the machine. When ready to restart the machine, set the “Clean/Off/Ice” selector switch to “Ice” and depress the “Start” button. The machine will start in a harvest, and begin a new freeze cycle upon completion.

SERVICE OPERATIONS

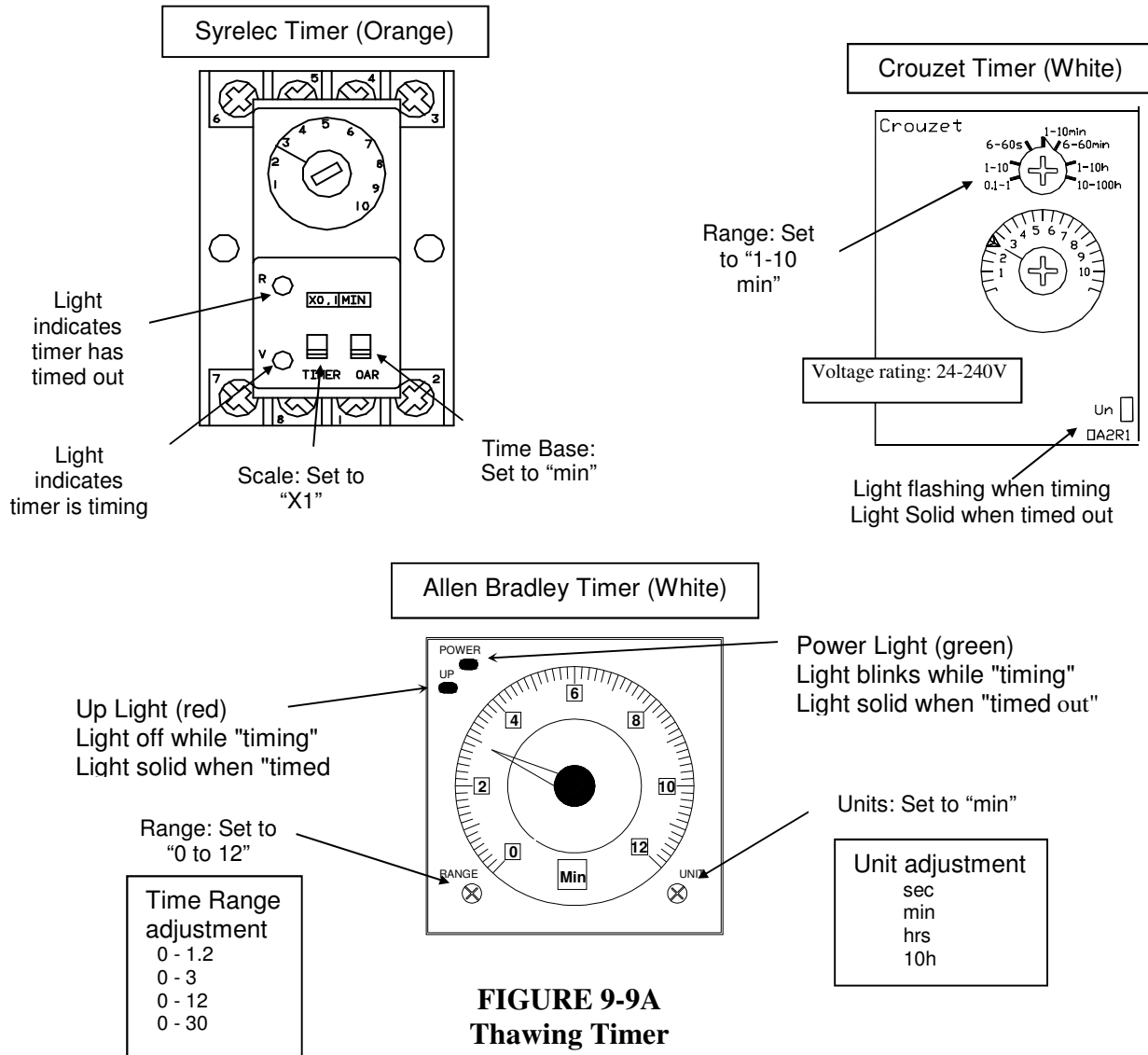

FIGURE 9-9A
Thawing Timer

Thawing Timer (Part No. [12A7503E22](#)) The thawing timer governs the ice thawing period. It is located inside the control panel (FIGURE 6-2). It is started by action of the freezer pressure switch (FPS) which energizes the "CR" relay.

Set the thawing period for at least 30 seconds longer than the time required to harvest the entire discharge of ice. If it should be necessary to change the setting of the timer, turn the adjustment screw clockwise to increase the time or counter-clockwise to decrease the time. Verify time after each adjustment.

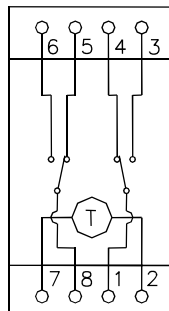

FIGURE 9-9B
Thawing Timer Wiring

Pumpdown The function of the pumpdown is to transfer all the liquid refrigerant from the freezer (evaporator) into the receiver. Pumpdown should only be performed when the freezer is clear of ice. Its main purposes are:

1. To check the total refrigerant charge.
2. To perform service or repair work on the machine.
3. To winterize the machine.
4. To prepare the machine for disconnecting and moving.
5. Before cleaning

To perform a pumpdown, follow this procedure:

1. Push manual harvest button to clear the freezer of all ice and stop operation.
2. Close the liquid stop valve (king valve) (58) at the receiver.
3. Open the water tank drain valve partially to allow a continuous flow of warm make-up water into the water tank, and still maintain a good level in the tank. An auxiliary supply of warm water (not to exceed 100°F) may be used if available. Warmer water affords a more complete pumpdown.
4. Start the machine and allow it to operate and complete one harvest
5. During the thaw cycle, close the 1/4" valve (69) at the top of the freezer to isolate the freezer pressure switch and prevent another thaw cycle.
6. Allow the machine to operate until the low-pressure switch stops the machine @ 20 PSIG. If a lower pressure is desired, it can be accomplished by jumping the low-pressure switch and starting and stopping the machine by the "Start" and "Stop" push buttons. Continually observe the oil level to make sure the oil is not carried from the compressor while operating at a low pressure.
7. Close the thawing gas stop valve (90), the receiver liquid return stop valve (91), the compressor suction valve (34), the compressor discharge valve and the oil return stop valve (70).

Removal Of Refrigerant From The Machine To transfer the refrigerant charge from the machine into a separate container, proceed as instructed above under "Pumpdown". This will isolate most of the refrigerant in the receiver and the recovery unit can be connected to the access port (44) of the hand stop valve (58) at the bottom of the receiver. Open the valve access port by turning the valve stem in (front seat) and operate the recovery unit until the system is considered empty.

! WARNING !
Approved recovery equipment, hoses, gages, and refrigerant containers must be used to comply with all local and federal EPA regulations.
! WARNING !

! WARNING !
Follow these instructions carefully. Severe personal injury can result from improper discharge of refrigerant.
! WARNING !

SERVICE OPERATIONS

! WARNING !
It is not recommended that refrigerant be transferred from a refrigeration system into a cylinder. If such a transfer is made, the refrigerant cylinder must be an approved CLEAN cylinder--free of any contaminants or foreign materials--and must be weighed continuously to assure contents do not exceed net weight specified by cylinder manufacturer or any applicable code requirements.
! WARNING !

Refrigerant Leaks In addition to testing the machine for leaks as instructed under “Refrigerant Charge”, it is advisable to again make a leak test after the unit has been in operation approximately one week. Any noticeable change in operating conditions, other than shown on the “Certificate of Test” may indicate a loss of refrigerant due to a leak. Always remove the refrigerant pressure from the vessel or tubing before repairs are attempted.

Non-condensable Gases Satisfactory operation of the machine is not possible if non-condensable gases (usually air) are present in the system. Excessive condensing pressure is an indication of such gases. Excessive condensing pressure in water-cooled condensers may also be due to the accumulation of scale in the cooling coil or due to insufficient cooling water or excessive water temperature. See “Water Cooled Condensers”, Section 7.

Compressor Motor Burnout There are several causes of compressor motor burnout. Some of these are described below.

1. **Low line voltage.** A compressor motor is designed to operate within the range of plus or minus 10% of its nameplate voltage. Low voltage requires the motor windings to carry more current at the same compressor load. When this current gets too high or is applied for an extended period, the motor windings overheat, resulting in a failure or burnout.
2. **Loss of refrigerant.** The hermetic compressor motor is maintained at proper operating temperature by passing cool suction gas over the motor windings. A loss of refrigerant can cause the winding to overheat resulting in a failure or burnout.
3. **High head pressure.** The system is designed to operate at 200 psig. Excessive head pressure adds refrigerating load on the compressor that can cause the windings to overheat and result in a failure or burnout.
4. **Moisture.** Moisture in contact with refrigerant oil and the presence of heat will form hydrochloric or hydrofluoric acid. The acid will destroy the insulation on the motor winding causing a short circuit which can increase motor temperature in excess of 3000°F. This extreme temperature will also create a sludge or black residue in the system.
5. **Mechanical failure.** Mechanical failure has been determined as a major cause of motor burnout. Bearing wear or wipe-out may allow rotor to drag--overheating the windings and burnout.

Whenever there is a compressor failure due to a motor burnout, it is important that the system be thoroughly cleaned before replacing the damaged compressor or otherwise the new compressor may also be damaged.

Solenoid Valves All solenoid valves are pilot operated with “floating” type diaphragms. For satisfactory operation, be sure that the manual opening stem is in the closed or automatic position. This means the stem is backed all the way out. Correct direction of stem rotation should be labeled on the stem seal nut.

Hansen 1 1/4” Solenoid Valve
Part No. [12A4200A1001](#)

208/230V coil
Part No. [126229](#)

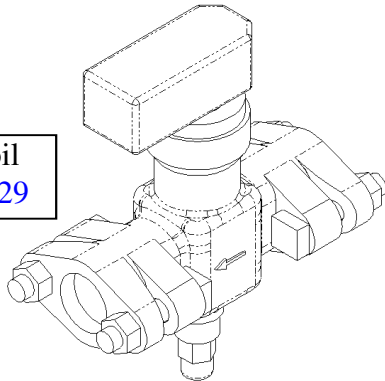

Hansen Rebuild Kit – HS7
Part No. [12A4199V52](#)

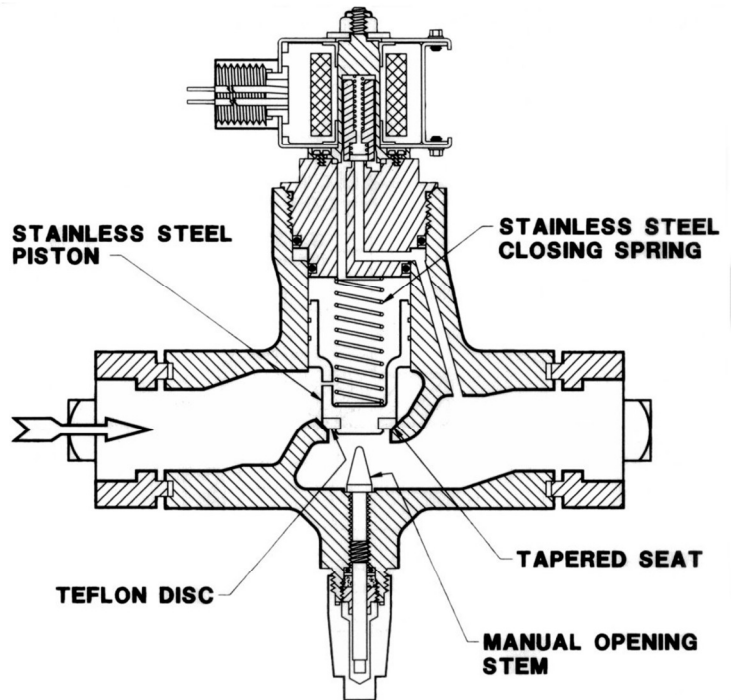
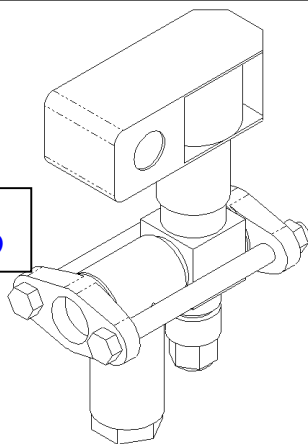

FIGURE 9-10A
Thawing Gas Solenoid Valve (“D” Valve)

Hansen 1/2” Solenoid Valve
Part No. [12A4200A0604](#)

208/230V coil
Part No. [126229](#)



Hansen Rebuild kit – HS8
Part No. [12A4199V51](#)

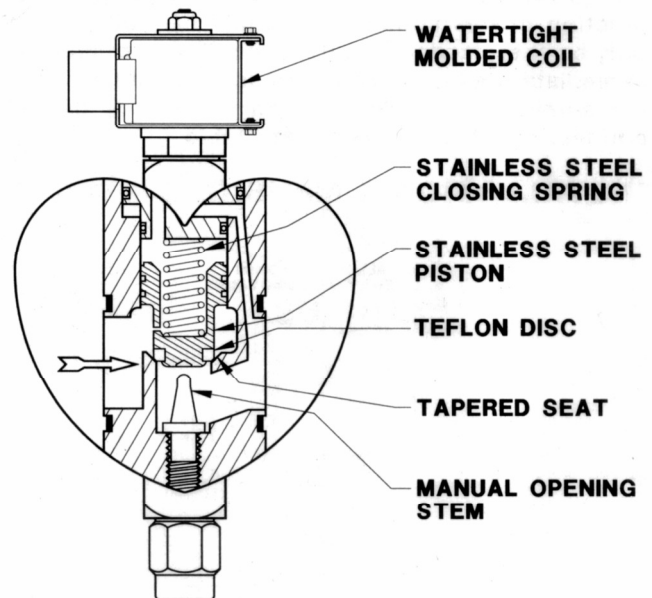

FIGURE 9-10B
Liquid Feed Solenoid Valve (“A1” & “A2” Valve)

SERVICE OPERATIONS

Capacity Control Valve (Internal Construction) A schematic illustration of the internal valve operation is shown in FIGURE 9-11. (Part No. [12A2110P0907](#))

In the normal (full capacity) operating position with the solenoid valve de-energized, the needle valve is seated on the lower port, and the unloading plunger chamber is exposed to suction pressure through the suction port. Since the face of the plunger is open to the suction chamber, the gas pressures across the plunger are equalized, and the plunger is held in the open position by the spring.

When the solenoid valve is energized, the needle valve is seated on the upper port, and the unloading plunger chamber is exposed to discharge pressure through the discharge pressure port. The differential between discharge and suction pressure forces the plunger down, sealing the suction port in the valve plate, thus preventing the entrance of suction vapor into the unloaded cylinders.

The seal on the unloading plunger minimizes any leakage in pressure so that a pumpdown cycle may be used with the valve either energized or de-energized without excessive compressor cycling.

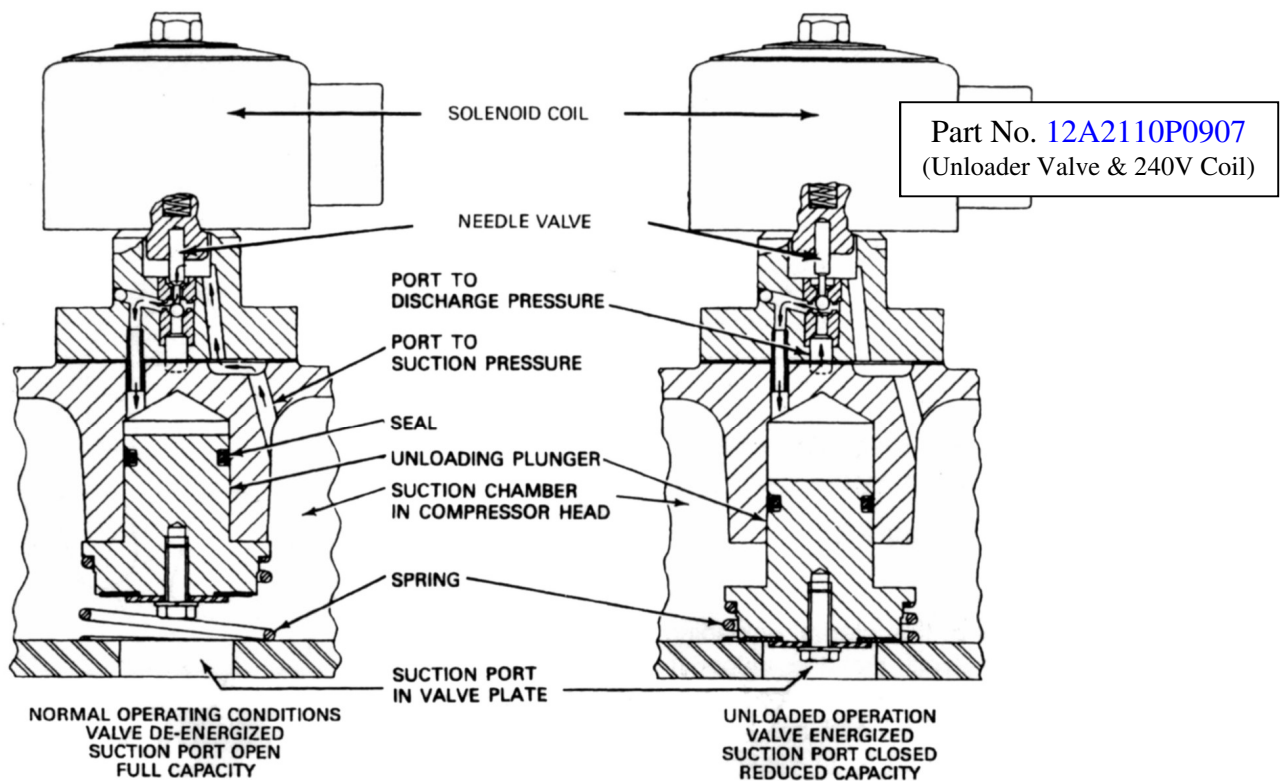

SCHEMATIC OPERATION OF INTERNAL UNLOADER VALVE
FIGURE 9-11

Copeland Compressor Unloader Valve

Loaded Operation (during freeze) This capacity control valve is controlled by an electric solenoid. When the solenoid is de-energized, the valve loads the cylinder bank (2 cylinders) as shown in the above figure.

Unloaded Operation (during thaw only) During the thaw cycle, the solenoid coil is energized. The needle valve is seated on the upper port, and the unloading plunger chamber is exposed to discharge pressure through the discharge pressure port. The differential between discharge and suction pressure forces the plunger down, sealing the suction port in the valve plate, thus preventing the entrance of suction vapor into the unloaded cylinders.

Circulating Water Pump Motor (Part No. [12A4020G01](#)- 60hz, [12A4020G08](#) – 50hz)

The motor bearings are prelubricated and sealed. They require no further lubrication. The pump should operate with the water level above the impeller housing. The pump is equipped with a mechanical seal that is self-adjusting and requires no lubrication. However, the pump should not be operated unless circulating water. The pump manufacturer recommends that a mechanical seal be kept as a spare. When ordering a seal, specify pump size, type, serial number, and manufacturer’s name as indicated on the nameplate.

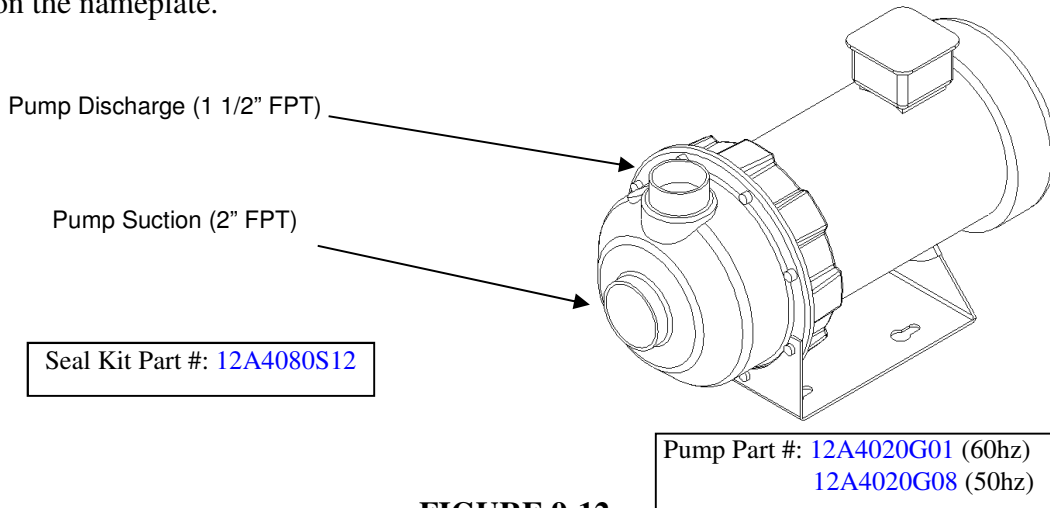
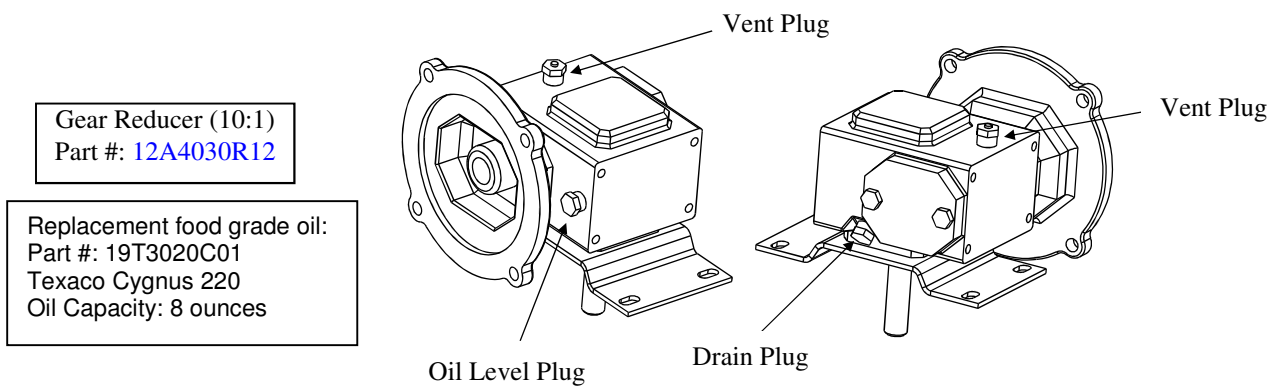

FIGURE 9-12
Circulating Water Pump

Cutter Gear Reducer (Part No. [12A4030R12](#)) The oil level for the gear reducer should be checked if there is evidence of a leak. It should be level with the plugged opening in the side of the gear housing. Use Mobile 600W cylinder oil or equal. Change oil once a year. The motor bearings are prelubricated and require no further lubrication. For additional information, refer to manufacturer’s instructions.



Note: Ventless gear reducer used after August 2010

FIGURE 9-13
Gear Reducer

SERVICE OPERATIONS

Component Removal and Replacement Operations

Cutter Motor The cutter motor's bearings are prelubricated and sealed and require no further lubrication. If the motor needs replacing, proceed as follows:

1. Turn power off and lockout disconnect.
2. Check terminals with voltmeter to confirm power is off.
3. Remove motor terminal cover and disconnect wires. Mark wires for ease of replacement.
4. Remove four cap screws around the motor flange and separate the motor from the reducer. Watch for shaft key that must be reinstalled later.
5. Check the motor electrically to confirm it is defective.
6. Apply Anti-Seize lubricant to the shaft of the replacement motor.
7. Position the shaft key in the motor keyway, align it with the reducer keyway and install the motor. Make sure the key stays in position as shaft is inserted.
8. Install the four cap screws to hold the motor in place on the reducer.
9. Connect the wires and install the terminal cover.
10. Check motor rotation to make sure the cutter turns in the proper direction. Reverse two wires at the motor if necessary to change rotation direction.

Cutter Gear Reducer To remove the gear reducer, proceed as follows: (See FIGURE 9-16)

1. Turn power off and lockout disconnect.
2. Remove motor from reducer.
3. Loosen (slightly) the four bolts and nuts holding the gear reducer in place.
4. Remove the four bolts holding the mounting plate to the water tank gear enclosure and remove the reducer and mounting plate from the tank.
5. Measure the distance between the top of drive gear and the mounting plate for future reference.
6. Remove the three cap screws from the gear and hub and install two 1/4"-20 x 2" long all thread set or cap screws in the threaded holes of the drive gear. These two screws can be used as jacking bolts to remove the gear from the tapered split hub.
7. The split hub can be removed by driving a screwdriver in the split and sliding the hub off the shaft.
8. The new gear reducer can then be installed by reversing the removal procedure.
9. Be sure the gear and hub is properly positioned on the shaft so it will have a full vertical mesh with the cutter ring gear.
10. Final gear meshing should be adjusted so there is only a slight amount of play between the ring gear and drive.
11. Make sure all bolts are tightened securely and there is no excessive gear noise when the cutter motor is running.

Water Tank Removal

1. Turn off and lock out power to the machine.
2. Turn off water supply and disconnect lines from the tank.
3. Drain the tank and disconnect pump suction tube and drain line tubing and water lines.
4. Disconnect the ice discharge chute.
5. Loosen bolts holding the tank to the cutter assembly until the tank rests on the bars.
6. Loosen bolts holding the tank supports.
7. The tank can then be removed to the side of the machine.
8. Make sure the rubber gasket is in place and aligned properly when the tank is installed and bolted to the freezer.

Cutter and Bearing Removal/Installation

Refer to FIGURES 9-14 & 9-15 for parts identification and location.

1. Turn off and lock out power to the machine.
2. Remove the cutter motor from the reducer.
3. Remove the water tank assembly and then the cutter assembly.
4. With a 1/4" or slightly smaller punch, reach in through the ice discharge opening, drive the spiral pin out of the disc hub and cutter shaft, and push or drive the disc off the shaft.
5. Lift the cutter assembly out of the bearing surface of the cutter. The surface should be smooth and free from nicks or burrs.
6. Inspect the bearing for wear. There should be no side movement between the shaft and bearing and the bearing thrust flange should be no thinner than 3/16" (it is 1/4" thickness new).
7. Before removing the bearing, reference mark the location of the bearing support on the side of tank.
8. Loosen and remove the three cap screws from the bearing support ends and lift the support out of the water tank.
9. Drive the 3/16" x 1/2" pin located in the side of the support hub in and through the bearing wall.
10. Now the bearing can be pressed or driven out of the support hub.
11. Try the new bearing on the cutter shaft to make sure it turns easily.
12. Press or drive the new bearing into the hub. Be careful not damage the bearing surfaces (the old bearing may be used as a driver).
13. Drill a 3/16" hole through the bearing wall, using the original hub hole as a pilot. Insert and drive the 3/16" pin flush with the outside of the hub, making sure the pin doesn't extend beyond the inner surface of the bearing.
14. Slide the new bearing and support onto the cutter shaft to make sure it spins freely. If it is tight, ream the bearing inner surface slightly until it turns free.
15. Install the bearing support in the tank, using the reference marks as a guide.
16. Slide the cutter and shaft into the bearing and check the cutter alignment. By laying a straight edge across the tank top flange, there should be 0" to 1/16" clearance between the rim of the cutter and the top of the tank flange. Loosen the bearing support cap screws and drive the support arms up or down for the proper alignment.
17. Tighten the support screws securely and finish assembly of the cutter and cutter disc.
18. Install the tank and other parts, reversing the procedure of removal.

SERVICE OPERATIONS

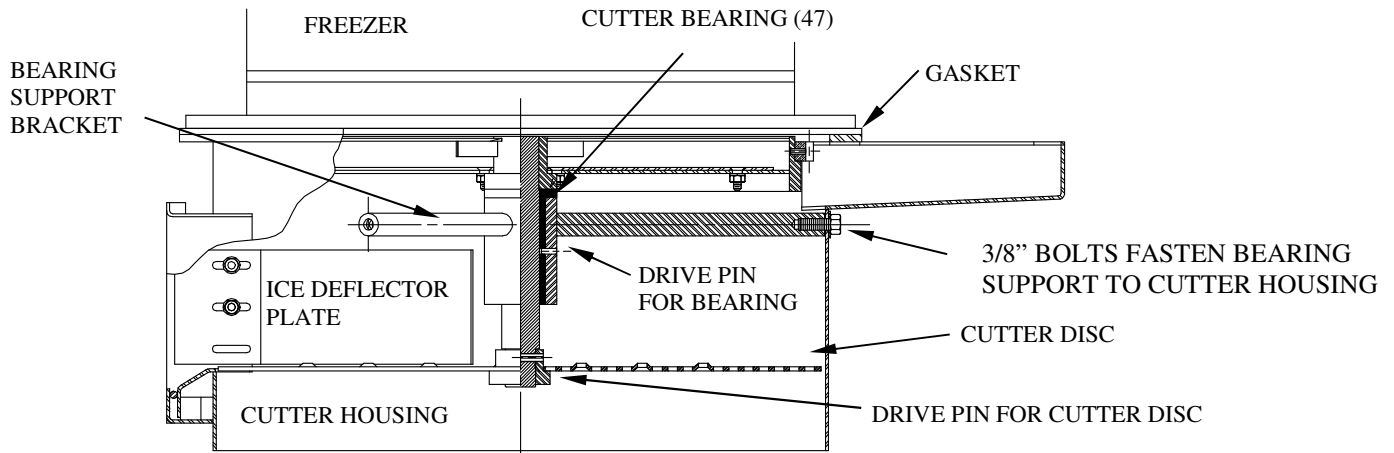

FIGURE 9-14
Cutter Assembly

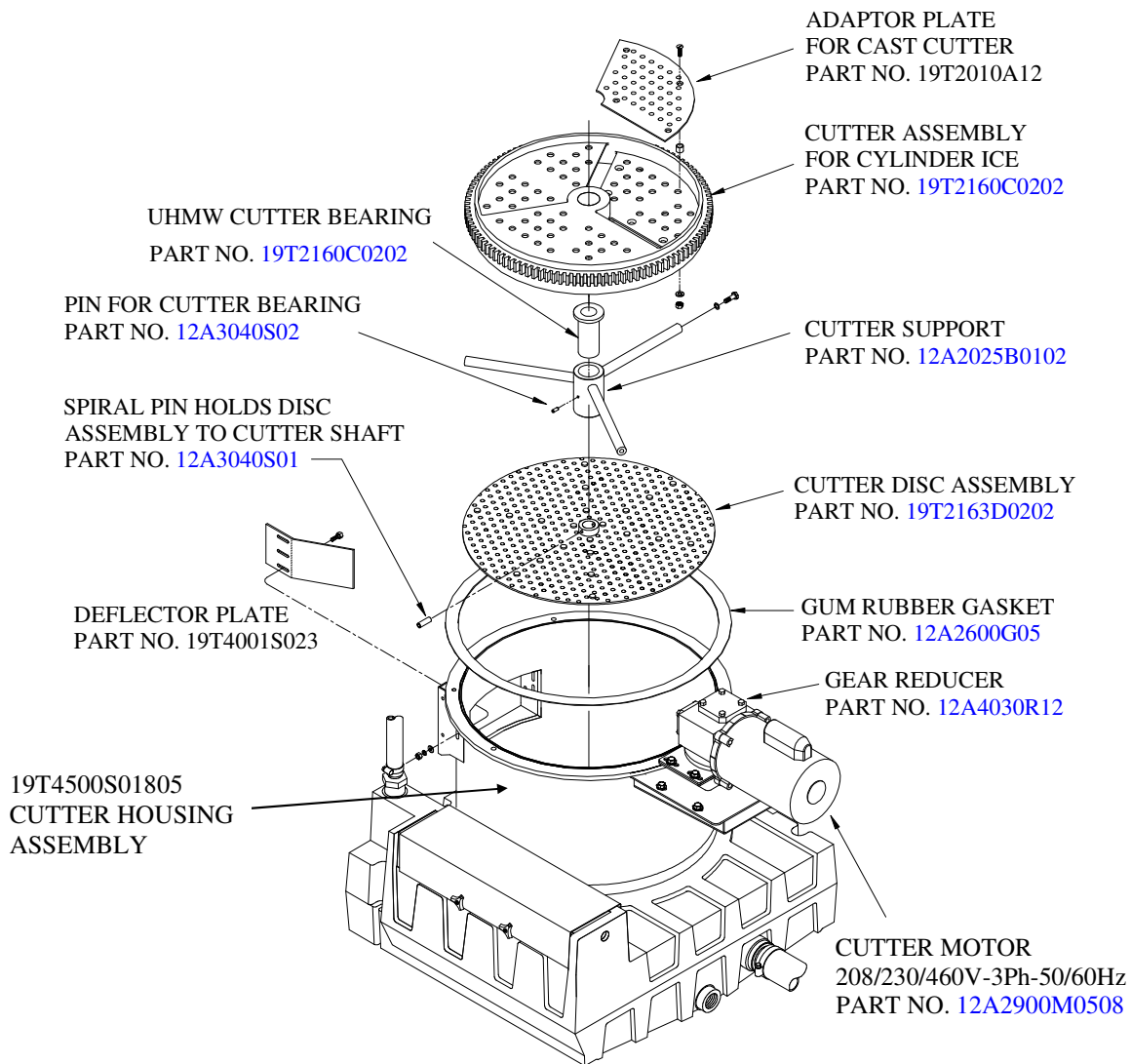

FIGURE 9-15
Cutter Parts (cylinder ice)

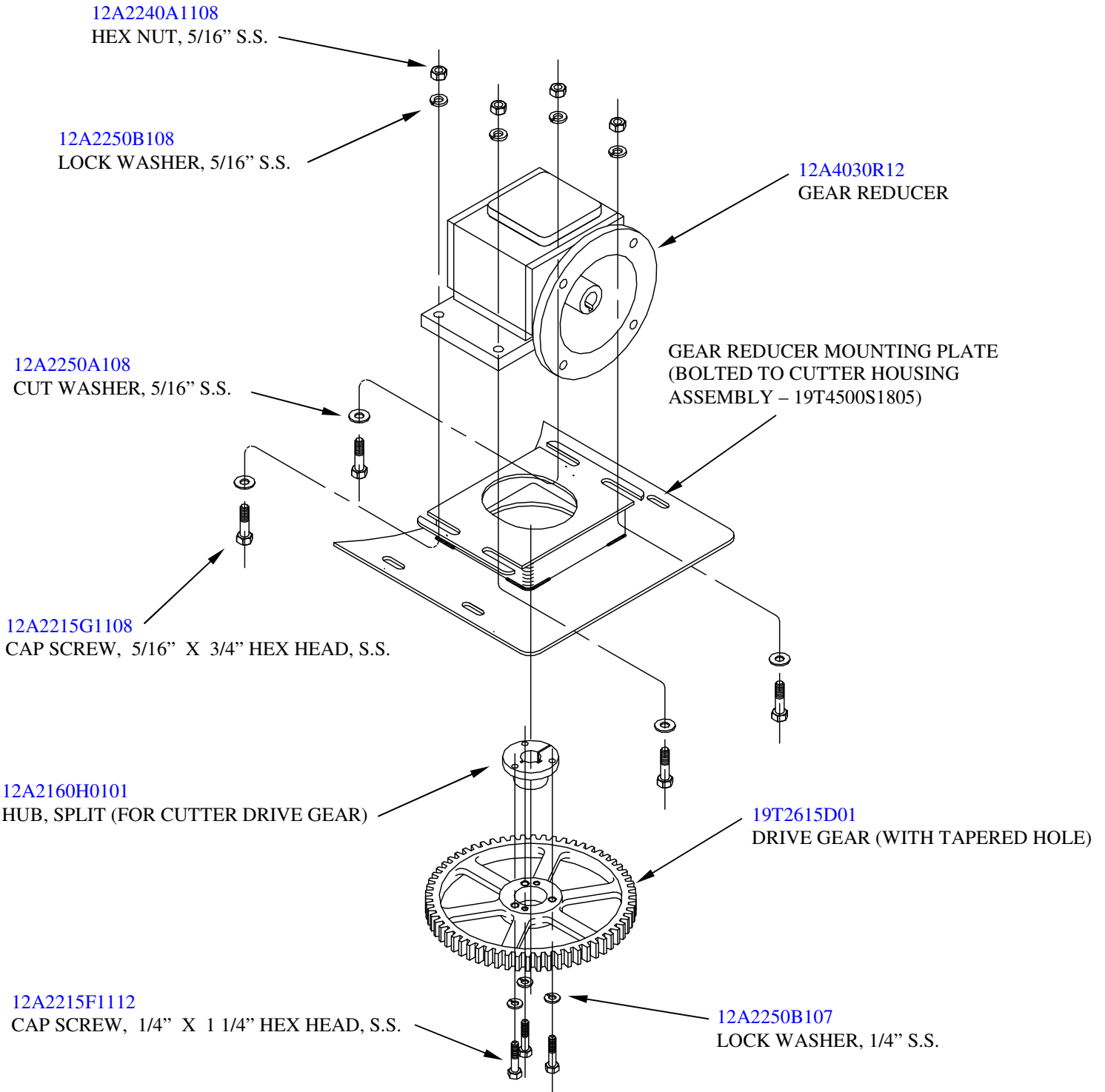

FIGURE 9-16
Cutter Drive Parts

SERVICE OPERATIONS

Crushed Ice Production. Your 10TA Tube-Ice[®] machine is capable of producing crushed ice with no loss of capacity. However, there are certain changes to be made in order to convert to crushed ice production:

Add:

1. Cutter Assembly (126413B).
2. Cutter Motor 3/4 HP:
 - a. 60hz: 12A2900M0601 (208-230V/460V, 3.2/1.6A)
 - b. 50hz: 12A2900M0603 (190/380V, 4.2/2.1A)
3. Gear Reducer 5:1 Ratio (12A4030R14)
4. Motor Starter:
 - a. 60hz : 208/230V machine - 12A7530E55UL (2.5-4.0A)
460V machine - 12A7530E54UL (1.6-2.5A)
 - b. 50hz: 200V machine - 12A7530E56UL (4.0-6.3A)
400V machine - 12A7530E54UL (1.6-2.5A)

- Change:
1. Raise the freezer pressure switch setting to make ice 3/16" thick (average).
 2. Reverse cutter direction.
 3. Reverse deflector.

Two people should normally accomplish this conversion process in 6-8 hours (or less). There must be ample room around the machine for the water tank removal. It is recommended that you have good quality water when attempting to produce crushed ice. If the ice is opaque and cloudy, it is subject to clog the cutter mechanism restrict ice discharge and bind the cutter. Also, you should not attempt to produce crushed ice when the make-up water temperature is below 50°F (10°C). Colder water can cause a build-up of ice fines in the tank and eventually result in "short-cycling".

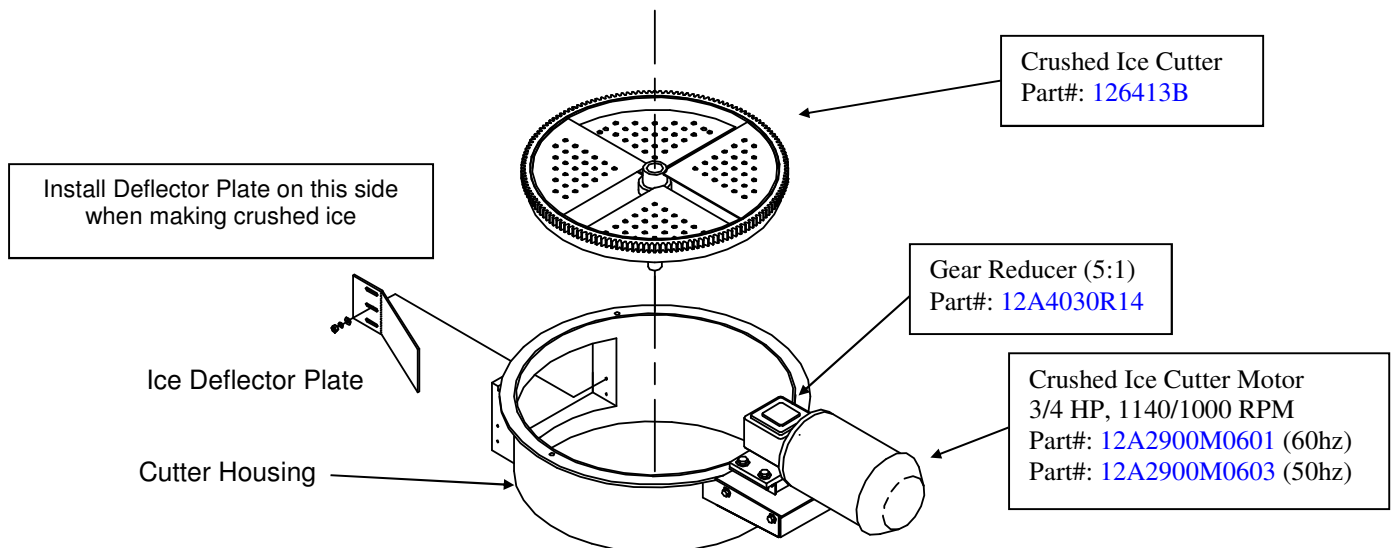

FIGURE 9-17
Cutter Parts (crushed ice option)

Defrost Pressure Switch –DPS (R404A Machines only). The DPS is used to regulate the pressure in the freezer during the harvest cycle. This pressure switch is wired in series with the D-valve (thaw gas valve), which opens and closes during the harvest cycle to maintain 90 to 95 psig in the evaporator.

CUT IN (CLOSE) ADJUSTING SCREW
SET AT 90 PSIG
(CW LOWERS SETTING)

CUT OUT (OPEN) ADJUSTING SCREW
SET AT 95 PSIG
(CW RAISES SETTING)

Vogt Part #: 12A2117B03

CE Approved machine
Vogt Part #: 12A2117B03CE

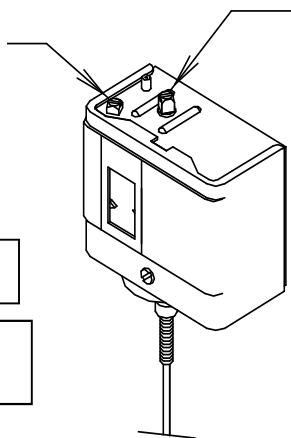

Defrost Pressure Switch (DPS)

FIGURE 9-19

Pressure Relief Valves. Pressure relief valves are installed on the freezer, receiver and the water cooled condenser. These valves are designed to vent in emergency conditions. This ensures vessel internal pressure does not exceed maximum allowable pressures.

PRESSURE RELIEF VALVES MUST BE REPLACED AFTER 5 YEARS OF SERVICE.

**BEFORE REPLACING RELIEF VALVE, REVIEW REQUIREMENTS PER
CURRENT LOCAL AND NATIONAL CODE.**

**VALVE REPLACEMENT SHOULD BE MADE BY PROPERLY TRAINED
PERSONNEL ONLY.**

**NOTE: IF RELIEF VALVE DISCHARGES, VALVE MUST BE REPLACED BECAUSE
SETTING OR SEAT TIGHTNESS MAY BE ALTERED.**

**CONTACT VOGT ICE PARTS DEPARTMENT FOR REPLACEMENT VALVES.
PHONE: 502-635-3000**

SERVICE OPERATIONS

Technical Service Bulletin

No. 88-5

All Models

Subject: Water Conditioning For Ice Cube Machines

The quality of the ice produced by a commercial ice cube machine can only be as high as the quality of the water which is used. Water which contains turbidity or sediment or which has a high concentration of dissolved minerals or gases will produce cloudy or opaque ice.

Ion exchange (zeolite) softening is used to advantage in many cases, as the softener removes iron and most forms of turbidity, and also prevents scale formation in the ice machines. However, softening the water by ion exchange does not reduce the concentration of minerals. In addition, most machines require a considerable blowdown to waste to prevent the buildup of the total dissolved solids and thus a considerable amount of softened water will be wasted.

All the sulfates, chlorides, and the sodium carbonate (listed below) have in general the same effect on the appearance of raw water ice and therefore, in this rough tabulation, can be grouped together.

Generally, the sodium carbonates can be considered 1 1/4 times as objectionable as the sulfates, and the chlorides about 3/4 as objectionable as the sulfates. Therefore, total the sulfates and chlorides separately and apply the factors:

Calcium Sulfate		Calcium Chloride
Magnesium Sulfate		Magnesium Chloride
Sodium Sulfate		Sodium Chloride
Sodium Carbonate		
Total Sulfates x 1.0	=	_____
Total Chlorides x 0.75	=	_____
Sodium Carbonate x 1.25	=	_____
Sum Total	=	_____

Dissolved solids below 171 ppm (10 grains per gallon) produces first quality ice, 256 ppm (15 g.p.g.) good quality ice, and 342 ppm (20 g.p.g.) an ice that is still marketable. If dissolved solids are between 342 ppm and 684 ppm (40 g.p.g.), acceptable ice quality ice is questionable, over 684 ppm, marketable ice cannot be expected.

When cloudy or opaque is produced because of the water quality, it is suggested that the water be analyzed by a reputable laboratory and their advice be followed.

Vogt Ice L.L.C.
Louisville, KY

10. Options and Accessories

Power Monitor

Wagner Model #: DTP-3

All Vogt Tube-Ice machine models are available from the factory with a three phase line voltage power monitor with LCD display. The units are also available for after market or retrofit installation. These units monitor line voltage inputs from 190 to 610 volts and provide protection against line voltage variances which can damage or destroy the compressor motor. Features include automatic system shutdown and restart based on current line conditions, a voltmeter, and a non-volatile system memory so settings are retained even if power is lost. If machine is ordered with this option the power monitor can be factory set to customer specifications. The Vogt Part number for a power monitor retrofit kit is [12A7700K01](#).

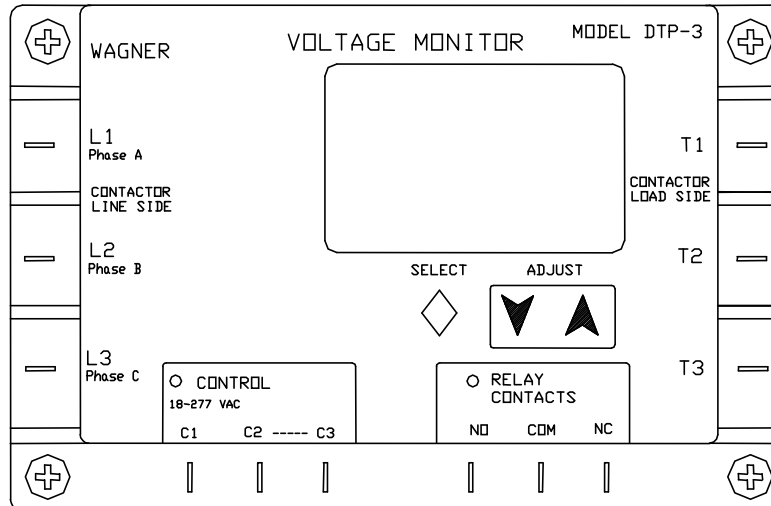

FIGURE 10-1
Power Monitor (Voltage Monitor)

The Display

The display normally shows the AB BC CA line voltages.

If the unit is waiting on a timer, that timer will be displayed. The timer display may be switched off by pressing SELECT. The LCD will then display the normal AB BC CA line voltage pairs.

Pressing the SELECT button once shows the contactor load side voltages (if the load side option is connected). The display automatically returns to the display of line side voltage after a few seconds.

Press the Select button to step through the parameters. As you step through the parameters, the selected parameter will flash. Use the up and down arrow keys to adjust to the desired operating value.

Parameter limits

Parameter	Minimum	Maximum	Default	Recommended Settings	Unit
Line Side Voltage (Nominal Voltage)	90	650	208	Supply voltage	Volts
Over Voltage (tolerance)	6	18	12	10	%
Under Voltage (tolerance)	6	18	12	10	%
Phase Unbalance	2	25	6	5	%
Lockout Time (Delay on Break)	0.1	25	0.5	120	Seconds
Delay Time (Delay on Make)	0	30	0	0	Seconds
Response Time (Delay on Fault)	0.1	20	2	2	Seconds
Control Mode	Off / Auto / On		Auto	On	N/A
Contactors Test	OFF	5	OFF	OFF	Volt Diff

TABLE 10-1
Power Monitor Parameters

Parameters adjustment (in order of display)

Active display of Line Voltage (this is the default normal display)

Active display of Load Side Voltage (if connected)

Voltage Set Point

(VAC Flashes) The value may be adjusted by pressing the up and down arrows. This may be set to the normal operating voltage of the device being protected in one volt increments.

Under/over Voltage Tolerance in %

(UNDERVOLTAGE/OVERVOLTAGE flashes)

The value may be adjusted by pressing the up and down arrows.

Imbalance Voltage Tolerance in %

(% IMBALANCE flashes) The value may be adjusted by pressing the up and down arrows.

Lockout Time in seconds

(SECONDS flashes) The value may be adjusted by pressing the up and down arrows. (This is the delay on break timer value)

Delay time in seconds and tenths of seconds

(RESP. SECONDS flashes) The value may be adjusted by pressing the up and down arrows. This is the time that a fault is allowed before shutdown occurs.

Control mode

(ON OFF AUTO flashes) The value may be adjusted to OFF (load will not turn on), ON (load will turn on whenever there are not faults and timers are finished) and AUTO (Load will turn on when there is a control input).

Contactors fault monitor mode

(CONTACTOR FAULT flashes) This option allows you to monitor the contactor and lock it out if the line voltage and load side varies by more than 5 volts. Pressing the up and down arrows selects off (default) or on. The load side of the contactor must be connected to the load terminals of the DTP-3 to use this option.

Display of fault memories

(MEM flashes) Pressing up or down displays the last fault conditions that took the unit off line. The first 25 faults are recorded. The top number displayed represents the fault memory. The middle number represents the total number of faults that have occurred since the fault memory was cleared.

To clear the memory, press and hold the up and down keys until the display is cleared.

Notes

If you press **SELECT** and do not change a parameter by pressing the up or down arrow keys, the DTP-3 automatically returns to displaying the line voltage in a few seconds.

The new settings are saved in permanent memory when the display returns to displaying the line voltage. The new settings may be verified by pressing the select button to sequence through the various parameters.

To prevent tripping on a 1 volt change, the DTP-3 automatically calculates cut-in voltages for the return from undervoltage conditions. The cut-out voltage is always based on user voltage and tolerance settings, while the cut-in voltage is 3% closer to the nominal voltage setting. This quality is sometimes referred to as hysteresis. This is to help reduce oscillation that may occur on weak power distribution system. When the load is switched off due to undervoltage, the line voltage will increase. Without the hysteresis, the monitor would switch the load back on, the line voltage would again drop, and cause a continuous on-off-on cycling.

PLC (Programmable Logic Controller)

Tube-Ice[®] machines are available with a Mitsubishi FX_{1N} 24MR programmable controller, FX_{2N}-8ER expansion module and a Mitsubishi E1012 Operator interface. The E1012 interface contains a real-time clock and 6 programmable function keys that allow for easy screen navigation and enhanced machine operation over the standard Tube-Ice[®] machine mechanical controls.

Note: The E1012 interface replaces the E150 and requires a 24VDC power supply to power the unit, where the E150 was power by the plc.

The PLC/Interface add features such as selectable “Automatic Restart” after a power failure, choice of timed or pressure switch controlled freeze cycles and Freezer “pumpdown”. For package units, the machine will automatically “Pumpdown” before cycling off.

The PLC/Interface provides programmable:

- Cutter delay (amount of time at start of harvest before cutter comes on)
- Conveyor control contacts (delay at start of harvest before conveyor comes on and run time).
- Automatic Restart after a Power Failure (enable/disable)
- Auto-restart time (delay time before restarting – recommended 2 hours for package machines)

The PLC provides **Machine Fault** indication with an alarm relay. The PLC will log when the “fault” occurred (time and date) and were in the cycle the machine was when the fault occurred.

Machine Faults:

- Compressor high discharge pressure
- Compressor low suction pressure
- Compressor oil pressure
- Compressor motor fault
- Cutter motor overload
- Water pump motor overload
- Long cycle - a freeze cycle lasting more than 60 minutes
- Short cycle - 3 consecutive freeze cycles 5 minutes or less in duration
- Power failure / Power return

Pumpdown Cycle

Package Machines: When machine is turned “off” or the bin control tells the machine to cycle off, the machine will complete the harvest cycle then go to the Pumpdown Mode. During the Pumpdown cycle, the compressor and water pump will be “on”. When the FPS (freezer pressure switch) makes, the machine will go through a 60 sec Pumpdown harvest. (Note: Pumpdown harvest can be turned off using the Main Setup screen.) After completing this short harvest, the machine will continue to pump down until it shuts off on low pressure.

Fault History log (5 faults) will be created and can be viewed through the E150 Interface. The PLC also logs (time and date) when a “power failure” occurs and when power is returned.

Cycle History log (10 cycles) will also be created and viewed with the interface.

The **PLC I/O Status** screen can be used to view PLC Inputs and Outputs without opening the control panel door. A Total cycle counter and hour meter can also be view with the.

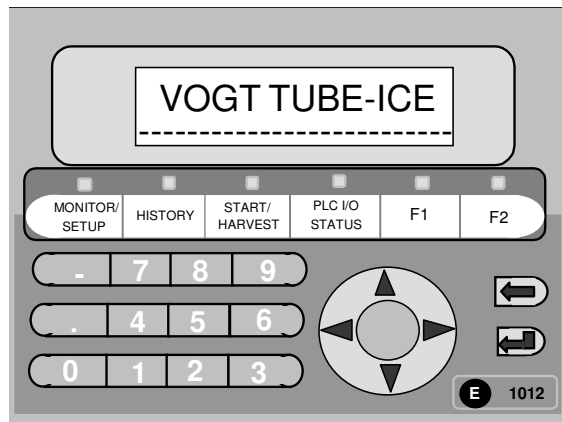

Mitsubishi E1012 Operator Interface

FIGURE 10-2
Mitsubishi HMI

MITSUBISHI PLC

The Mitsubishi Programmable controller contains 14 inputs and 10 outputs on the base unit with an additional 4 input and 4 outputs on an expansion module. The power supply for the unit can be 100-240VAC, 50/60 Hz and is internally fused for 3A. The inputs are 24VDC internally fused for 5-7mA and supplied by the PLC. All 24VDC control wiring is blue in color and is distinguished from the red 240VAC or 120VAC control wiring. The outputs are externally fused for 2A. Outputs 1 and 2 are dry contacts used for high side control interlock and conveyor control. Outputs 0, 3-11 & 20-23 are relay type with 120V or 200/240 V connections.

The LED indicators on the right hand side of the Mitsubishi PLC indicate the power, run and error status of the PLC. When power is on to the PLC and the run/stop switch is in the run position the power and run indicators will be illuminated. A solid or flashing error light indicates a processor or program error. The LED indicators on the upper right hand side of the PLC, indicates the input status and LED indicators on the lower right hand side of the PLC indicate the output status. If the input (X#) indicator is illuminated, then the PLC is receiving the input. If the output (Y#) indicator is illuminated, then the PLC is sending the output. Use of these LED's will be helpful in troubleshooting the machine.

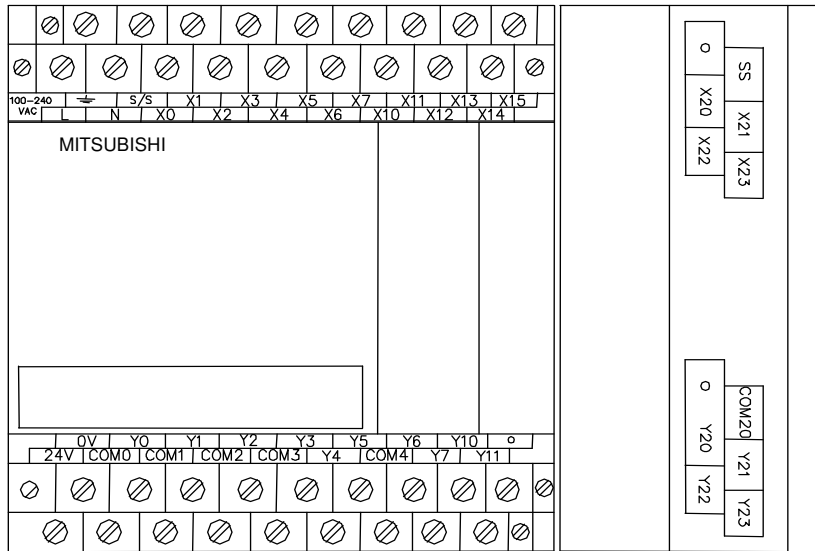

Mitsubishi FX_{1N}-24MR PLC and FX_{2N}-8ER-ES/UL

FIGURE 10-3
Mitsubishi PLC

Inputs	Description	Outputs	Description
0	Not used	0	Not used
1	Not used	1	High Side Control Interlock
2	Start / Manual Harvest Button	2	Conveyor Control Contact
3	Selector Switch (Clean position)	3	ET - Elapsed Timer
4	Selector Switch (Ice position) in series w/Bin control	4	Water Pump motor starter
5	Freezer Pressure switch	5	Alarm
6	Compressor overload for 4D & 6D without CoreSense	6	D-sol (defrost solenoid valve)
7	Cutter Motor overload	7	Not used
10	Pump Motor overload	10	Float switch / A-sol (liquid feed valve(s))
11	CoreSense (Oil press safety for comp without CoreSense)	11	Cutter motor starter
12	High / Low pressure safety		
13	Not used		
14	Not used		
15	Not used		
Expansion Module			
20	Not used	20	UN-sol (compressor unloader)
21	Not used	21	Not used
22	Not used	22	Not used
23	Not used	23	Not used

TABLE 10-2
PLC Input / Output Table

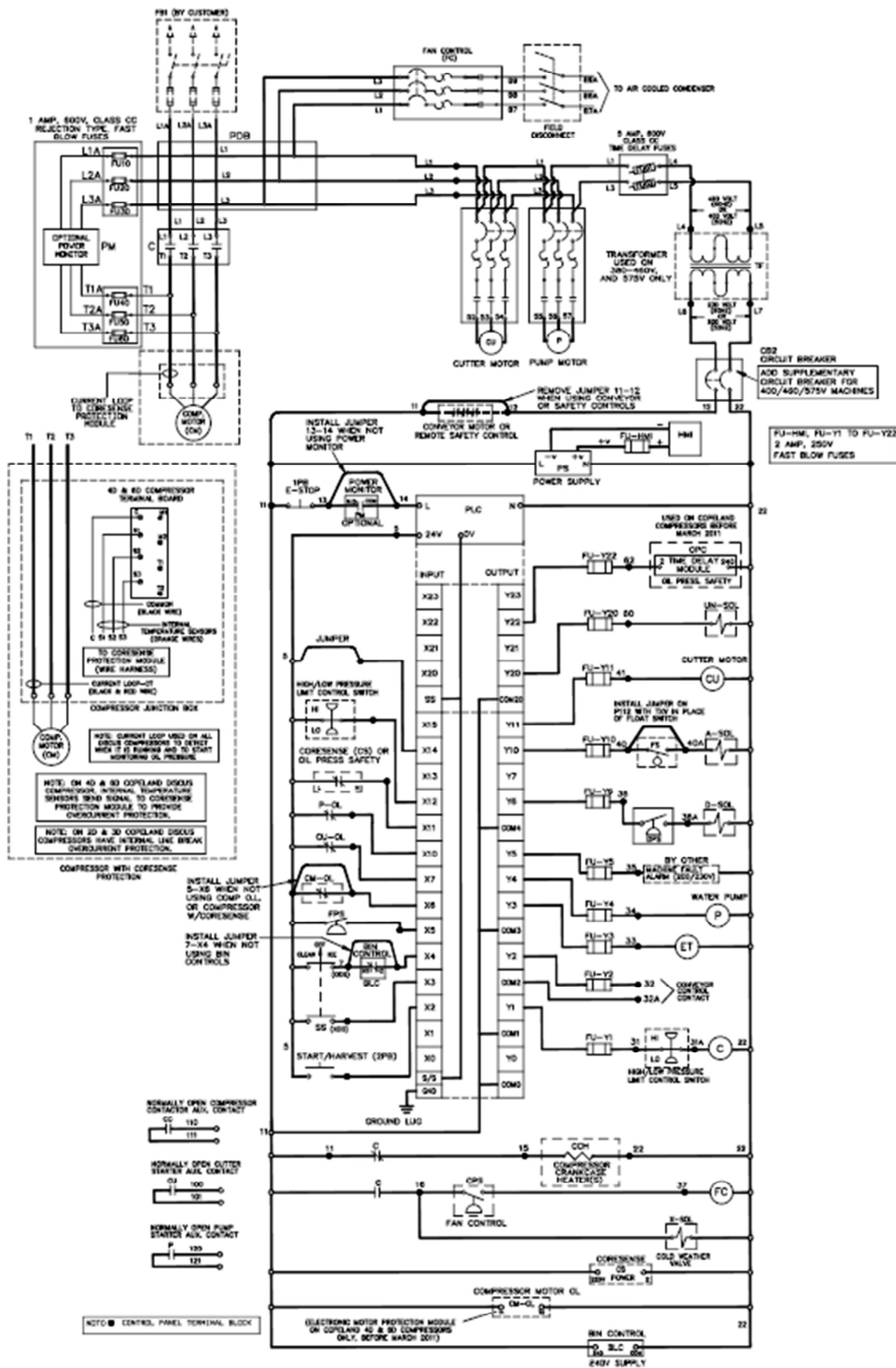

FIGURE 10-4
Wiring Schematic – Mid Size Machine (P112, P118 & P18XT)

BLANK

11. Tables & Charts

P18FXT SPECIFICATIONS, 208-230 Volt-3 Phase- 60Hz

Tube Size	inches (cm)	1 (2.54)	1 1/4 (3.17)	1 1/2 (3.18)
Nominal Capacity ⁽¹⁾	lbs/day (Kg/day)	20,000 (9,072)	18,000 (8,165)	16,500 (7,484)
Overall Dimensions (LxWxH)	inches (meters)	48 x 60 x 129 (1.2x1.5x3.3)	48 x 60 x 129 (1.2x1.5x3.3)	48 x 60 x 129 (1.2x1.5x3.3)
Shipping Weight	lbs (Kg)	4800 (2177)	4800 (2177)	4800 (2177)
Operating Weight	lbs (Kg)	4900 (2222)	4900 (2222)	4900 (2222)
Refrigerant Charge (R404A)	lbs (Kg)	500 (238)	500 (238)	500 (238)
Total FLA Water Cooled ⁽²⁾		122	122	122
Total FLA Air Cooled ⁽²⁾		139	139	139
Maximum Fuse	WC / AC	220/250	220/250	220/250
Minimum Ampacity	WC / AC	125/153	125/153	125/153
Water Requirements				
-makeup ⁽³⁾	gpm (m ³ /Hr)	3.0 (0.68)	3.0 (0.68)	3.0 (0.68)
-condenser ⁽⁴⁾	gpm (m ³ /Hr)	70 (15.9)	70 (15.9)	70 (15.9)
Connection Sizes				
-makeup water	FPT	3/4"	3/4"	3/4"
-tank drain	FPT	3/4"	3/4"	3/4"
-condenser water inlet	FPT	2"	2"	2"
-condenser water outlet	MPT	2"	2"	2"
-AC condenser inlet	ODC	2 1/8"	2 1/8"	2 1/8"
-AC condenser outlet	ODC	1 3/8"	1 3/8"	1 3/8"
Compressor -HP/KW/FLA		21 / 15.7 / 105	21 / 15.7 / 105	21 / 15.7 / 105
Water Pump -HP/KW/FLA		1.5 / 2.1 / 4.8	1.5 / 2.1 / 4.8	1.5 / 2.1 / 4.8
Cutter Motor -HP/KW/FLA		0.5 / 0.7 / 2.2	0.5 / 0.7 / 2.2	0.5 / 0.7 / 2.2
THR	Btu/hr (kW)	275,000 (73.3)	275,000 (73.3)	275,000 (73.3)
Marley Cooling Tower⁽⁵⁾				
-dim. (LxWxH)	ft (meters)	4 x 5 x 6.5 (1.2x1.5x2.0)	4 x 5 x 6.5 (1.2x1.5x2.0)	4 x 5 x 6.5 (1.2x1.5x2.0)
-shipping weight	lbs (Kg)	650 (295)	650 (295)	650 (295)
-operating weight	lbs (Kg)	1260 (571)	1260 (571)	1260 (571)
-fan (HP/KW/FLA)		1 / 0.8 / 3.6	1 / 0.8 / 3.6	1 / 0.8 / 3.6
Tower Pump				
-flow	gpm (m ³ /Hr)	78 (17.7)	78 (17.7)	78 (17.7)
-TDH minimum	ft (m)	80 (24.4)	80 (24.4)	80 (24.4)
-HP/KW/FLA		3 / 2.2 / 9.6	3 / 2.2 / 9.6	3 / 2.2 / 9.6
-connections (inlet x outlet)	FPT	4" x 3"	4" x 3"	4" x 3"
-shipping weight	lbs (Kg)	65 (29.5)	65 (29.5)	65 (29.5)
Bohn Air-Cooled Condenser⁽⁶⁾				
- # of Fans / HP		4 / 1.5	4 / 1.5	4 / 1.5
-total KW/FLA		4.5 / 28	4.5 / 28	4.5 / 28
-inlet connection	ODC	2 1/8"	2 1/8"	2 1/8"
-outlet connection	ODC	1 3/8"	1 3/8"	1 3/8"
-shipping weight	lbs (Kg)	1520 (690)	1520 (690)	1520 (690)
-operating weight	lbs (Kg)	1265 (574)	1265 (574)	1265 (574)

(1) Nominal capacity is based on 70°F makeup water, 100°F condensing temperature, 70°F amb, and 0% blowdown.
 (2) FLA for 460 volt models is approximately 1/2 that of 230 volt models. Total FLA does not include cooling tower.
 (3) Makeup water is maximum value and includes 10 gallons per cycle blowdown.

(4) Condenser flow rate is for 85°F entering water temperature and 100°F condensing.
 (5) Tower sized for 80°F wet bulb temperature.
 (6) Recommended air-cooled condenser is based on 15°F TD.

Vogt reserves the right to change designs and specifications without notice.

Table 11-1

TABLES & CHARTS

P18FXT SPECIFICATIONS, 380 Volt-3 Phase- 50Hz

Tube Size	inches (cm)	1 (2.54)	1 1/4 (3.17)	1 1/2 (3.18)
Nominal Capacity ⁽¹⁾	lbs/day (Kg/day)	20,000 (9,072)	18,000 (8,165)	16,500 (7,484)
Overall Dimensions (LxWxH)	inches (meters)	48 x 60 x 129 (1.2x1.5x3.3)	48 x 60 x 129 (1.2x1.5x3.3)	48 x 60 x 129 (1.2x1.5x3.3)
Shipping Weight	lbs (Kg)	4800 (2177)	4800 (2177)	4800 (2177)
Operating Weight	lbs (Kg)	4900 (2222)	4900 (2222)	4900 (2222)
Refrigerant Charge (R404A)	lbs (Kg)	500 (238)	500 (238)	500 (238)
Total FLA Water Cooled ⁽²⁾		66.5	66.5	66.5
Total FLA Air Cooled ⁽²⁾		75	75	75
Maximum Fuse	WC / AC	150/160	150/160	150/160
Minimum Ampacity	WC / AC	83/97	83/97	83/97
Water Requirements				
-makeup ⁽³⁾	gpm (m ³ /Hr)	3.0 (0.68)	3.0 (0.68)	3.0 (0.68)
-condenser ⁽⁴⁾	gpm (m ³ /Hr)	70 (15.9)	70 (15.9)	70 (15.9)
Connection Sizes				
-makeup water	FPT	3/4"	3/4"	3/4"
-tank drain	FPT	3/4"	3/4"	3/4"
-condenser water inlet	FPT	2"	2"	2"
-condenser water outlet	MPT	2"	2"	2"
-AC condenser inlet	ODC	2 1/8"	2 1/8"	2 1/8"
-AC condenser outlet	ODC	1 3/8"	1 3/8"	1 3/8"
Compressor -HP/KW/FLA		24 / 17.9 / 62.5	24 / 17.9 / 62.5	24 / 17.9 / 62.5
Water Pump -HP/KW/FLA		2 / 1.5 / 3.6	2 / 1.5 / 3.6	2 / 1.5 / 3.6
Cutter Motor -HP/KW/FLA		0.5 / 0.4 / 1.1	0.5 / 0.4 / 1.1	0.5 / 0.4 / 1.1
THR	Btu/hr (kW)	275,000 (73.3)	275,000 (73.3)	275,000 (73.3)
Marley Cooling Tower⁽⁵⁾				
-dim. (LxWxH)	ft (meters)	4 x 5 x 6.5 (1.2x1.5x2.0)	4 x 5 x 6.5 (1.2x1.5x2.0)	4 x 5 x 6.5 (1.2x1.5x2.0)
-shipping weight	lbs (Kg)	650 (295)	650 (295)	650 (295)
-operating weight	lbs (Kg)	1260 (571)	1260 (571)	1260 (571)
-fan (HP/KW/FLA)		1 / 0.8 / 3.6	1 / 0.8 / 3.6	1 / 0.8 / 3.6
Tower Pump				
-flow	gpm (m ³ /Hr)	78 (17.7)	78 (17.7)	78 (17.7)
-TDH minimum	ft (m)	80 (24.4)	80 (24.4)	80 (24.4)
-HP/KW/FLA		3 / 2.2 / 9.6	3 / 2.2 / 9.6	3 / 2.2 / 9.6
-connections (inlet x outlet)	FPT	4" x 3"	4" x 3"	4" x 3"
-shipping weight	lbs (Kg)	65 (29.5)	65 (29.5)	65 (29.5)
Bohn Air-Cooled Condenser⁽⁶⁾				
- # of Fans / HP		4 / 1.5	4 / 1.5	4 / 1.5
-total KW/FLA		4.5 / 14	4.5 / 14	4.5 / 14
-inlet connection	ODC	2 1/8"	2 1/8"	2 1/8"
-outlet connection	ODC	1 3/8"	1 3/8"	1 3/8"
-shipping weight	lbs (Kg)	1520 (690)	1520 (690)	1520 (690)
-operating weight	lbs (Kg)	1265 (574)	1265 (574)	1265 (574)

(1) Nominal capacity is based on 70°F makeup water, 100°F condensing temp, 70°F amb, and 0% blowdown.

(2) FLA for 200 volt models is approximately 2 times that of 380 volt models. Total FLA does not include cooling tower.

(3) Makeup water is maximum value and includes 10 gallons per cycle blowdown.

(4) Condenser flow rate is for 85°F entering water temperature and 100°F condensing.

(5) Tower sized for 80°F wet bulb temperature.

(6) Recommended air-cooled condenser is based on 15°F TD.

Vogt reserves the right to change designs and specifications without notice.

Table 11-2

P18FXT Capacity Ratings

Makeup Water Temp. Deg. F	Rated Capacity (lbs/day)											
	60Hz						50Hz					
	Cylinder			Crushed			Cylinder			Crushed		
	1"	1 1/4"	1 1/2"	1"	1 1/4"	1 1/2"	1"	1 1/4"	1 1/2"	1"	1 1/4"	1 1/2"
40	21700	19100	17600	22568	19864	18304	21700	19100	17600	22568	19864	18304
41	21660	19080	17580	22526	19843	18283	21660	19080	17580	22526	19843	18283
42	21620	19060	17560	22485	19822	18262	21620	19060	17560	22485	19822	18262
43	21580	19040	17540	22443	19802	18242	21580	19040	17540	22443	19802	18242
44	21540	19020	17520	22402	19781	18221	21540	19020	17520	22402	19781	18221
45	21500	19000	17500	22360	19760	18200	21500	19000	17500	22360	19760	18200
46	21440	18960	17460	22298	19718	18158	21440	18960	17460	22298	19718	18158
47	21380	18920	17420	22235	19677	18117	21380	18920	17420	22235	19677	18117
48	21320	18880	17380	22173	19635	18075	21320	18880	17380	22173	19635	18075
49	21260	18840	17340	22110	19594	18034	21260	18840	17340	22110	19594	18034
50	21200	18800	17300	22048	19552	17992	21200	18800	17300	22048	19552	17992
51	21140	18760	17260	21986	19510	17950	21140	18760	17260	21986	19510	17950
52	21080	18720	17220	21923	19469	17909	21080	18720	17220	21923	19469	17909
53	21020	18680	17180	21861	19427	17867	21020	18680	17180	21861	19427	17867
54	20960	18640	17140	21798	19386	17826	20960	18640	17140	21798	19386	17826
55	20900	18600	17100	21736	19344	17784	20900	18600	17100	21736	19344	17784
56	20840	18560	17060	21674	19302	17742	20840	18560	17060	21674	19302	17742
57	20780	18520	17020	21611	19261	17701	20780	18520	17020	21611	19261	17701
58	20720	18480	16980	21549	19219	17659	20720	18480	16980	21549	19219	17659
59	20660	18440	16940	21486	19178	17618	20660	18440	16940	21486	19178	17618
60	20600	18400	16900	21424	19136	17576	20600	18400	16900	21424	19136	17576
61	20540	18360	16860	21362	19094	17534	20540	18360	16860	21362	19094	17534
62	20480	18320	16820	21299	19053	17493	20480	18320	16820	21299	19053	17493
63	20420	18280	16780	21237	19011	17451	20420	18280	16780	21237	19011	17451
64	20360	18240	16740	21174	18970	17410	20360	18240	16740	21174	18970	17410
65	20300	18200	16700	21112	18928	17368	20300	18200	16700	21112	18928	17368
66	20240	18160	16660	21050	18886	17326	20240	18160	16660	21050	18886	17326
67	20180	18120	16620	20987	18845	17285	20180	18120	16620	20987	18845	17285
68	20120	18080	16580	20925	18803	17243	20120	18080	16580	20925	18803	17243
69	20060	18040	16540	20862	18762	17202	20060	18040	16540	20862	18762	17202
70	20000	18000	16500	20800	18720	17160	20000	18000	16500	20800	18720	17160
71	19830	17850	16350	20623	18564	17004	19830	17850	16350	20623	18564	17004
72	19660	17700	16200	20446	18408	16848	19660	17700	16200	20446	18408	16848
73	19490	17550	16050	20270	18252	16692	19490	17550	16050	20270	18252	16692
74	19320	17400	15900	20093	18096	16536	19320	17400	15900	20093	18096	16536
75	19150	17250	15750	19916	17940	16380	19150	17250	15750	19916	17940	16380
76	18980	17100	15600	19739	17784	16224	18980	17100	15600	19739	17784	16224
77	18810	16950	15450	19562	17628	16068	18810	16950	15450	19562	17628	16068
78	18640	16800	15300	19386	17472	15912	18640	16800	15300	19386	17472	15912
79	18470	16650	15150	19209	17316	15756	18470	16650	15150	19209	17316	15756
80	18300	16500	15000	19032	17160	15600	18300	16500	15000	19032	17160	15600
81	18130	16340	14850	18855	16994	15444	18130	16340	14850	18855	16994	15444
82	17960	16180	14700	18678	16827	15288	17960	16180	14700	18678	16827	15288
83	17790	16020	14550	18502	16661	15132	17790	16020	14550	18502	16661	15132
84	17620	15860	14400	18325	16494	14976	17620	15860	14400	18325	16494	14976
85	17450	15700	14250	18148	16328	14820	17450	15700	14250	18148	16328	14820
86	17280	15540	14100	17971	16162	14664	17280	15540	14100	17971	16162	14664
87	17110	15380	13950	17794	15995	14508	17110	15380	13950	17794	15995	14508
88	16940	15220	13800	17618	15829	14352	16940	15220	13800	17618	15829	14352
89	16770	15060	13650	17441	15662	14196	16770	15060	13650	17441	15662	14196
90	16600	14900	13500	17264	15496	14040	16600	14900	13500	17264	15496	14040

Capacity rating based on 70°F ambient conditions, 100°F SDT temperature.
 Capacity rating is average for the model. Individual machines may vary up to 5% above or below.
 Capacity rating is for clear ice production with makeup water containing no more than 200ppm total dissolved solids.

Table 11-3

TABLES & CHARTS

Condensing Temp. °F	Entering Water Temp. °F	Leaving Water Temp. °F	Water Flow gpm	Pressure Drop	Average Total Heat of Rejection
100	50	110	9.5	0.9	275000
100	55	109	10	1.0	275000
100	60	108	12	1.3	275000
100	65	105	14	1.8	275000
100	70	103	17	2.7	275000
100	75	100	22	4.7	275000
100	80	97	34	11	275000
100	85	93	70	48	275000
105	90	95	110	119	275000
110	95	100	110	119	275000

Table 11-4
Condenser Water Usage

Make-Up Water Temp. °F	Cylinder Ice			Crushed Ice		
	Tube Size			Tube Size		
	1"	1 1/4"	1 1/2"	1"	1 1/4"	1 1/2"
40	2.56	2.25	2.19	3.00	2.62	2.54
50	2.49	2.21	2.14	2.92	2.58	2.49
60	2.42	2.16	2.09	2.84	2.53	2.43
70	2.35	2.12	2.04	2.74	2.47	2.38
80	2.14	1.93	1.86	2.49	2.25	2.16
90	1.93	1.74	1.68	2.25	2.02	1.94

Includes 10 gallons per cycle blowdown

Table 11-5
Make-Up Water Usage (gpm)

			Suction Pressure (psig)		Discharge Pressure (psig)		Harvest Times (secs)			Ice per cycle Average (lbs)	Freeze Time (minutes)					
			End of Freeze		Average during Freeze		First Ice	All Ice Out	Total Harvest		Water Temperature (deg. F)					
			R22	R404A	R22	R404A					90	80	70	60	50	
60	HZ	C	1"	34	45	200	240	15	120	150	235	17.9	16.0	14.4	13.9	13.5
		Y	1 1/4"	32	42	200	240	15	120	150	245	21.0	18.8	17.0	16.6	16.2
		L	1 1/2"	28	38	200	240	20	120	150	235	19.8	17.8	16.0	15.6	15.2
	R	C	1"	36	47	200	240	15	105	150	175	11.7	10.4	9.3	8.9	8.6
		Y	1 1/4"	34	45	200	240	15	105	150	175	13.7	12.1	10.9	10.6	10.3
		U	1 1/2"	30	40	200	240	15	105	150	175	13.3	11.8	10.6	10.3	10.0
50	HZ	C	1"	34	45	200	240	15	120	150	235	17.9	16.0	14.4	13.9	13.5
		Y	1 1/4"	32	42	200	240	15	120	150	245	21.0	18.8	17.0	16.6	16.2
		L	1 1/2"	28	38	200	240	20	120	150	235	19.8	17.8	16.0	15.6	15.2
	R	C	1"	36	47	200	240	15	105	150	175	11.7	10.4	9.3	8.9	8.6
		Y	1 1/4"	34	45	200	240	15	105	150	175	13.7	12.1	10.9	10.6	10.3
		U	1 1/2"	30	40	200	240	20	105	150	175	13.3	11.8	10.6	10.3	10.0

Table 11-6
Normal Operating Vitals

RECOMMENDED SPARE PARTS LIST
Vogt Model P18FXT Tube-Ice® Machine

<u>QTY</u>	<u>PART NUMBER</u>	<u>DESCRIPTION</u>
1	12A2117E04	Freezer pressure switch
1	12A7503E22	Thawing timer
1	12A7517E27	CR Relay, 208/230v.,50/60hz coil
1	12A7516E23	PF Contactor, 208/230v.,50/60hz coil
1	See Page 6-5	CU/P Starter, 208/230v.,50/60hz coil
1	See Page 6-5	Compressor Contactor, 208/230v.,50/60hz.
1	12A2900M0508	Cutter motor, 1/2 HP, 3 ph
2	12A4200H0402P	Make-up water float valve, Lead Free, Plastic
1	12B2020R01	Cutter bearing
1	12A2600G15	Gasket for freezer cover
1	12A2600G05	Gasket for water tank
1	12A7509E12	Crankcase heater, 100W, Insert type (Copeland Discus Compressor)
1	12C2590G08	Suction pressure gage (R22)
1	12C2590G09	Discharge pressure gage (R22)
1	12C2590G1	Suction pressure gage (R404A)
1	12C2590G11	Discharge pressure gage (R404A)
1	12A7500E22	Float Switch Assembly
1	12-6229	Coil for Hansen solenoid valve (208/240V, 50/60HZ)

TO ORDER SPARE PARTS, PLEASE CONTACT YOUR DISTRIBUTOR.

TABLES & CHARTS

TEMPERATURE - PRESSURE CHART
FOR COMMON REFRIGERANTS

DegF	R-12	R-22	R-502	R-134a	MP-39	R-404a	R717
-50	-7.6	-3.0	0.2	-9.0	-9.1	0.0	-7.0
-48	-7.2	-2.4	0.7	-8.7	-8.7	0.8	-6.5
-46	-6.8	-1.7	1.5	-8.3	-8.3	1.6	-6.0
-44	-6.3	-1.0	2.3	-8.0	-7.9	2.5	-5.4
-42	-5.8	-0.2	3.2	-7.6	-7.4	3.4	-4.9
-40	-5.4	0.5	4.1	-7.1	-7.1	5.5	-4.3
-38	-4.9	1.3	5.0	-6.7	-6.6	6.5	-3.6
-36	-4.4	2.2	6.0	-6.3	-6.1	7.5	-3.0
-34	-3.8	3.0	7.0	-5.8	-5.6	8.6	-2.3
-32	-3.3	4.0	8.1	-5.3	-5.2	9.7	-1.6
-30	-2.7	4.9	9.2	-4.8	-4.4	10.8	-0.8
-28	-2.1	5.9	10.3	-4.2	-4.1	12.0	0.0
-26	-1.5	6.9	11.5	-3.8	-3.4	13.2	0.8
-24	-0.8	7.9	12.7	-3.0	-2.9	14.5	1.7
-22	-0.1	9.0	14.0	-2.4	-2.2	15.8	2.6
-20	0.6	10.1	15.3	-1.8	-1.7	17.1	3.5
-18	1.3	11.3	16.7	-1.1	-1.0	18.5	4.5
-16	2.1	12.5	18.1	-0.4	-0.2	20.0	5.6
-14	2.8	13.8	19.5	0.3	0.4	21.5	6.7
-12	3.7	15.1	21.0	1.1	1.4	23.0	7.8
-10	4.5	16.5	22.6	1.9	2.2	24.6	8.9
-8	5.4	17.9	24.2	2.8	3.1	26.3	10.2
-6	6.3	19.3	25.8	3.6	3.9	28.0	11.4
-4	7.2	20.8	27.5	4.5	4.8	29.8	12.8
-2	8.2	22.4	29.3	5.5	5.7	31.6	14.2
0	9.2	24.0	31.1	6.5	6.7	33.5	15.6
2	10.2	25.6	32.9	7.5	7.7	35.6	17.1
4	11.2	27.3	34.9	8.5	8.8	37.4	18.6
6	12.3	29.1	36.9	9.6	9.9	39.4	20.3
8	13.5	30.9	38.9	10.8	11.0	41.6	21.9
10	14.6	32.8	41.0	12.0	12.2	43.9	23.7
12	15.8	34.7	43.2	13.1	13.4	46.0	25.4
14	17.1	36.7	45.4	14.4	14.6	48.3	27.4
16	18.4	38.7	47.7	15.7	15.9	50.7	29.3
18	19.7	40.9	50.0	17.0	17.2	53.1	31.3
20	21.0	43.0	52.5	18.4	18.6	55.6	33.3
22	22.4	45.3	54.9	19.9	20.0	58.2	35.5
24	23.9	47.6	57.5	21.4	21.5	59.9	37.7
26	25.4	49.9	60.1	22.9	23.0	63.6	40.0
28	26.9	52.4	62.8	24.5	24.6	66.5	42.4
30	28.5	54.9	65.6	26.1	26.2	69.4	44.8
32	30.1	57.5	68.4	27.8	27.9	72.3	47.4
34	31.7	60.1	71.3	29.5	29.6	75.4	50.0
36	33.4	62.8	74.3	31.3	31.3	78.5	52.7
38	35.2	65.6	77.4	33.2	33.2	81.8	55.5
40	36.9	68.5	80.5	35.1	35.0	85.1	58.4
42	38.8	71.5	83.8	37.0	37.0	88.5	61.3
44	40.7	74.5	87.0	39.1	39.0	91.9	64.4
46	42.7	77.6	90.4	42.0	41.0	95.5	67.6
48	44.7	80.7	93.9	43.3	43.1	99.2	70.8
50	46.7	84.0	97.4	45.5	45.3	102.9	74.2

DegF	R-12	R-22	R-502	R-134a	MP-39	R-404a	R717
50	46.7	84.0	97.4	45.5	45.3	102.9	74.2
52	48.8	87.3	101.0	47.7	60.0	109.0	77.7
54	51.0	90.8	104.8	50.1	62.0	113.0	81.3
56	53.2	94.3	108.6	52.3	65.0	117.0	84.9
58	55.4	97.9	112.4	55.0	68.0	121.0	88.7
60	57.7	101.6	116.4	57.5	70.0	125.0	92.6
62	60.1	105.4	120.4	60.1	73.0	130.0	96.6
64	62.5	109.3	124.6	62.7	76.0	134.0	100.7
66	65.0	113.2	128.8	65.5	79.0	139.0	104.9
68	67.6	117.3	133.2	68.3	82.0	144.0	109.3
70	70.2	121.4	137.6	71.2	85.0	148.0	113.7
72	72.9	125.7	142.2	74.2	89.0	153.0	118.3
74	75.6	130.0	146.8	77.2	92.0	158.0	123.1
76	78.4	134.5	151.5	80.3	95.0	164.0	127.9
78	81.3	139.0	156.3	83.5	99.0	169.0	132.8
80	84.2	143.6	161.2	86.8	102.0	174.0	137.9
82	87.2	148.4	166.2	90.2	106.0	180.0	143.2
84	90.2	153.2	171.4	93.6	109.0	185.0	148.5
86	93.3	158.2	176.6	97.1	113.0	191.0	154.1
88	96.5	163.2	181.9	100.7	117.0	197.0	159.7
90	99.8	168.4	187.4	104.4	121.0	203.0	165.5
92	103.1	173.7	192.9	108.2	125.0	209.9	171.4
94	106.5	179.1	198.6	112.1	129.0	215.0	177.5
96	110.0	184.6	204.3	116.1	133.0	222.0	183.7
98	113.5	190.2	210.2	120.1	138.0	229.0	190.1
100	117.2	195.9	216.2	124.3	142.0	235.0	196.1
102	120.9	201.8	222.3	128.5	146.0	242.0	203.3
104	124.7	207.7	228.5	132.9	151.0	249.0	210.2
106	128.5	213.8	234.9	137.3	156.0	256.0	217.2
108	132.4	220.0	241.3	142.8	160.0	264.0	224.4
110	136.4	226.4	247.9	146.5	165.0	271.0	231.7
112	140.5	232.8	254.6	151.3	170.0	279.0	239.2
114	144.7	239.4	261.5	156.1	175.0	286.0	246.9
116	148.9	246.1	268.4	161.1	180.0	294.0	254.8
118	153.2	252.9	275.5	166.1	185.0	302.0	262.8
120	157.7	259.9	282.7	171.3	191.0	311.0	271.0
122	162.2	267.0	290.1	176.6	196.0	319.0	279.4
124	166.7	274.3	297.6	182.0	202.0	328.0	288.0
126	171.4	281.6	305.2	187.5	207.0	336.0	296.7
128	176.2	289.1	312.9	193.1	213.0	345.0	305.7
130	181.0	296.8	320.8	198.9	219.0	354.0	314.8
132	185.9	304.6	328.9	204.7	225.0	364.0	324.2
134	191.0	312.5	337.1	210.7	231.0	373.0	333.7
136	196.2	320.6	345.4	216.8	237.0	383.0	343.4
138	201.3	328.9	353.9	223.0	243.0	392.0	353.4
140	206.6	337.3	362.6	229.4	250.0	402.0	363.5
142	212.0	345.8	371.4	235.8	256.0	412.0	373.8
144	217.5	354.5	380.4	242.4	263.0	423.0	384.4
146	223.1	363.4	389.5	249.2	269.0	434.0	395.2
148	228.8	372.3	398.9	256.0	277.0	444.0	406.1
150	234.6	381.5	408.4	263.0	283.0	449.0	432.0

TABLE 11-7
All pressures are in lbs/in² gage (psig).

REFERENCE INFORMATION**CONVERSION FACTORS: English to Metric**

To Convert	From	To	Multiply by
Area	ft ²	m ²	9.2903e-2
	in ²	m ²	6.416 e-4
Energy	BTU	Joule (J)	1054.48
	hp	BTU/Hr	2546.2
	kW	hp	1.34
Length	ft.	m.	0.3048
	in.	m.	0.0254
Pressure	lbf/ft ²	Paschals	47.88
	lbf/in ² (psi)	Paschals	6894.76
	in. Hg	psi	0.491
	in H ₂ O	psi	0.03612
Temperature	°F	°C	$T_C = 5/9 * (T_F - 32)$
	°C	°F	$T_F = (9/5 * T_C) + 32$
Volume	ft ³	m ³	2.8317e-2
	gal(U.S.)	m ³	3.7854e-3
	ft ³	gal(U.S.)	7.48

TABLE 11-8**CONSTANTS**

Specific heat of Water	1 BTU/(lbm °F)
Specific heat of Air	4.19 kJ/(kg °C) 0.24 BTU/(lbm °F)
Tube-Ice Density	32-35 lbs/ft ³
Ice Latent Heat	144 BTU/hr
Water Sensible Heat	1 BTU/(lb °F)
Ice Melting Effect (IME) 1 Ton Refrigeration	12,000 BTU/hr
Atmospheric pressure	14.7 psia
Weight of Water	62.4 lbs/ft ³ 8.33 lbs/gal
1 gpm water	12013 lb/day
Weight of air	0.0749 lbs/ft ³ 0.0100 lbs/gal
1 Horsepower	2545.6 BTU/hr
1 Kilowatt	1.34 horsepower
Gravitational accel.	9.81 m ² /sec

TABLE 11-9

BLANK

12. Index

A

A Valves	4-1, 5-1
Accumulator	4-1, 5-1
Adding Refrigerant	5-4
Air - cooled Condenser Wiring (3 phase)	3-12
Air-Cooled Condenser	9-5
Air-Cooled Condenser Data	3-9
Air-Cooled Condenser Installation	3-7
Air-Cooled Piping Schematic	4-4
Air-Cooled Units	9-5
Assembly Drawing , Air-Cooled	1-4, 1-5, 1-6
Assembly Drawing , Water Cooled	1-7, 1-8, 1-9
Automatic blowdown	9-1

B

Basic Product Warranty	inside back cover
Bearing, Cutter	9-19
Bill of Lading	2-1
Bin, Thermostat Installation	3-13
Bin, Thermostat Setup	3-14
Blowdown	9-1
Burnout, Compressor	9-14

C

Capacity Ratings	11-3
Capillary By-pass	9-4
Charging Refrigeration Systems	1-2
Check Valve	4-2
Checklist, Installation Review	3-15
Chemical Cleaning	7-5
Circuit Breaker, Control	6-2, 6-4, 6-5, 6-6
Circulating Water Pump / Motor	9-17
Clean/Off/Ice Switch	6-1, 6-3, 6-4
Cleaning Procedure	7-1
Compressor	7-6
Compressor Crankcase Heater	9-11
Compressor Lubrication	7-6
Compressor Motor Burnout	9-14
Compressor Unloader	9-16
Compressor, Contactor	6-2, 6-4, 6-5, 6-6
Compressor, Motor Protection	9-6
Condenser Cleaning	9-5
Condenser Fan Contactor (FC)	6-2, 6-4, 6-5, 6-6
Condenser Fan Switch	9-5
Condenser Piping (Cold Weather Valve Kit)	3-9
Condenser Water Usage	11-4
Condenser, Air-cooled Cleaning	9-5
Condenser, Air-cooled Heat Rejection	3-8
Condenser, Pressure Switch (CPS)	9-5
Condenser, Water Cooled	3-2, 7-4
Control Circuit Protection	9-11
Control Panel / Parts	6-5, 6-6

Control, Relay (CR)	6-2, 6-4, 6-5, 6-6
Cooling Tower	3-2
CoreSense	6-9, 9-10, 9-11
Crankcase Heater	7-6, 9-11
Crushed Ice Production	9-22
Cutter & Bearing Removal/Installation	9-19
Cutter Drive Parts	9-21
Cutter Gear Reducer	7-7, 9-16, 9-17
Cutter Motor	9-18
Cutter, Assembly	9-20
Cutter, Bearing	9-19
Cutter, Bearing Support	9-19
Cutter, Disc Assembly	9-20
Cutter, Drive Parts	9-21
Cutter, Gear Reducer	9-17, 9-18
Cutter, Motor	9-18
Cutter Assembly	9-20
Cutter Parts (crushed Ice)	9-22
Cutter Parts (cylinder ice)	9-20

D

D Valve (Thawing Gas)	4-1, 9-15
Drive gear	9-21

E

Electrical Connection	3-5
Electrical Schematic All Voltages 50-60 Hz.	6-7
Electrical, Controls	6-1
Enclosure	6-1
Energy Saving	1-1
Equivalent Feet Due To Friction	3-11

F

Fan Contactor (FC)	6-2, 6-4, 6-5, 6-6
Filter/Drier	4-1
Float Switch	9-2
Float Valve (Make-Up Water)	9-1
Freeze Period	4-2
Freeze-Up Due To Extended Freezing Period	8-4
Freeze-Up Due To Ice Failing To Discharge	8-5
Freezer	4-1
Freezer Pressure Switch	9-3

G

Gear Reducer	9-17
--------------------	------

H

Hand Expansion Valve	9-3
Harvest Period	4-2
Head Pressure	9-5
Heat Exchanger	4-1
Heater, Crankcase	9-11

INDEX

H (Cont.)

High Head Pressure (Air-Cooled)-----	8-10
High Head Pressure (Water Cooled)-----	8-9
High/Low Pressure Switch-----	9-4
History, Tube-Ice®-----	1-1
HMI, Interface-----	10-5
Hub, Cutter Drive Gear-----	9-21

I

Ice Bin Thermostat Location-----	3-13
Ice Capacity-----	11-3
Important Safety Notice-----	1-2
Inspection, First Arrival-----	2-1
Installation-----	3-1
Installation Review: A Checklist-----	3-14
Introduction-----	1-1

J, K**L**

Low Compressor Oil Level-----	8-8
Low Ice Capacity-----	8-7
Low Pressure Switch-----	9-4
Lubrication-----	7-6
Lubrication, Compressor-----	7-6
Lubrication, Cutter Gear Reducer-----	7-7

M

Machine Ratings (50 Hz., 24 HP)-----	11-2
Machine Ratings (60 Hz., 21 HP)-----	11-1
Machine Room-----	2-1
Machine Won't Run-----	8-2, 8-3
Maintenance-----	7-1
Maintenance Program-----	7-1
Make-Up Water-----	3-1
Manual Harvest Push Button-----	5-2, 6-1
Metric Conversion-----	11-7
Mechanical Cleaning-----	7-5, 7-6

N

NEMA-----	2-1
Nomenclature, Piping-----	4-2
Non-Condensable Gases-----	9-14
Normal Operating Vitals-----	11-4

O

Oil Pressure Safety Control-----	9-9
Operating Tips-----	5-3
Operation Vitals-----	11-4
Optional Equipment, Power Monitor-----	10-2
Overload Protection, Cutter Motor Starter---	6-2, 6-4, 6-5, 6-6
Overload Protection, Pump Motor Starter---	6-2, 6-4, 6-5, 6-6

P

Pin, for Cutter Bearing-----	9-20
Piping and Drain Connections-----	3-1
Piping Schematic, Air-cooled-----	4-4
Piping Schematic, Nomenclature-----	4-2

Piping Schematic, Water cooled-----	4-3
PLC (Programmable Logic Controller)-----	10-4, 10-6
Poor Ice Quality-----	8-6
Power Connection-----	3-5
Power Monitor-----	10-1
Preventive Maintenance-----	7-8
Preventive Maintenance Program-----	7-8
Preview-----	1-1
Principle of Operation-----	4-1
Pump Down-----	9-12
Pump Overload Protection-----	6-2, 6-4, 6-5, 6-6
Pump, Contactor-----	6-2, 6-4, 6-5, 6-6

Q**R**

R-22 (HCFC-22)-----	1-2, 2-1, 5-1
R404A-----	5-1
Receipt of Machine-----	2-1
Receiver-----	4-1
Refrigerant Charge-----	5-1
Refrigerant Leaks-----	5-1, 9-14
Refrigerant, Removal-----	9-13
Refrigeration System Review-----	5-1
Rotation Check-----	3-6

S

Safety Notice-----	1-2
Safety Symbols and What They Mean-----	1-3
Safety Valves-----	2-1
Sanitizing Procedure-----	7-2
Shipping Papers-----	2-1
Solenoid Valve-----	9-15
Space Diagram (Air-Cooled Machine)-----	3-3
Space Diagram (Water Cooled Machine)-----	3-4
Special Precautions-----	1-2
Start Push Button (PB1)-----	5-2, 5-3, 6-3, 6-4, 6-5
Start-Up-----	5-2
Start-Up Checklist-----	3-15
Storage (prior to installation and start-up)-----	2-2
Suction Cut-Off Unloader-----	9-16
Symptoms, Troubleshooting-----	8-2

T

Telephone Number, Vogt-----	1-1
Temperature-Pressure Chart-----	11-6
Thawing, Chamber-----	4-1
Thawing, Timer (T)-----	6-2, 6-4, 6-5, 6-6, 9-12
Thermostat, Bin Installation-----	3-13
Thermostat, Setup-----	3-14
Timer, Thawing-----	6-2, 6-4, 6-5, 6-6, 9-12
Trap (AC Piping)-----	3-11
Troubleshooting-----	8-1

U

Unloader - Loaded Operation (Freeze Period)-----	9-16
Unloader - Unloaded Operation (Harvest Period)-----	9-16

V

Vitals, Operation-----11-4

W

Water Conditioning ----- 3-1
 Water Cooled Condenser ----- 3-2, 3-4, 7-4
 Water Cooled Condenser Cleaning ----- 7-5
 Water cooled Machine, Installation----- 3-4
 Water Cooled Piping Schematic ----- 4-3
 Water Cooled Units----- 9-5
 Water Distributors ----- 7-3
 Water Pump Motor-----9-17
 Water Quality----- 3-1
 Water Regulating Valve ----- 9-5
 Water Supply and Drain, Water Cooled----- 3-1, 3-2
 Water Supply and Drains, Air-cooled ----- 3-1, 3-4
 Water Tank----- 7-4
 Water Tank Removal-----9-19
 Water Usage, Condenser -----11-4
 Water Usage, Make-up -----11-4
 Wiring and Electrical Connection ----- 3-5
 Wiring Schematic , Air Cooled Condenser -----3-12
 Wiring Schematic, All Voltages - 50/60 Hz ----- 6-7

X

X Valve ----- 4-2

Y, Z

