



P18AL
TUBE-ICE®
MACHINE

Manual Part Number [12A4171M09](#)

Service Manual

\$50⁰⁰

NOTICE

This manual is the property of the owner of this particular Tube-Ice® machine.

Model # _____ Serial # _____.

It is to be left on the premises with this machine at all times. After start-up, it should be stored in a safe place where it can be readily available when needed for future reference in maintaining troubleshooting or servicing.

Failure to comply with this notice will result in unnecessary inconvenience and possible additional expenses.

This manual is intended as an informational tool for the installation, operation, maintenance, troubleshooting, and servicing of this equipment. If an existing situation calls for additional information not found herein, we suggest that you contact your distributor first. If further assistance or information is needed, please feel free to contact the factory at 502-635-3000 or FAX at 502-635-3024.

IMPORTANT: The Warranty Registration/Start-Up Report found in the front of this manual is to be completed and returned to the factory promptly after the official start-up.

Please return to: TUBE ICE®, LLC
 1000 W. Ormsby Ave.
 Louisville, KY 40210

Tube Ice L.L.C.
1000 W. Ormsby
Louisville, KY 40210
 (502) 635-3235
 FAX #502-635-3024



Vogt Order Number: _____

THIS FORM MUST BE SENT TO
VOGT TO ACTIVATE WARRANTY

Warranty Registration / Start-Up Form
(Medium & Large Machines)

Model Number: _____ **Serial Number:** _____

This form must be filled out completely and signed by the customer in order to assure acceptance by Vogt.

Date of Start-Up: _____ Form Completed By: _____

AC Condenser Model Number: _____ AC Condenser Serial Number: _____

Water Treatment System? Yes No Manufacturer: _____ Model: _____

Bin Manufacturer: _____ Model: _____ Bin Capacity: _____ lbs.

Distributor

Company Name: _____ Phone: _____

Address: _____ City: _____ State: _____ Zip: _____

Service Company

Company Name: _____ Phone: _____

Address: _____ City: _____ State: _____ Zip: _____

Customer (location of equipment)

Company Name: _____ Phone: _____

Address: _____ City: _____ State: _____ Zip: _____

PRE-OPERATION CHECK

- Service Manual on hand
 - Machine room suitable 50°F minimum, 110°F maximum
 - Power Supply _____ V _____ PH _____ Hz (machine not running)
 - Compressor crankcase heater on 12 hour minimum
 - All valves opened or closed as tagged
 - Solenoid valve stems in auto position
 - System leak checked/tight
 - Auxiliary equipment overloads wired into control circuit
 - Water supply and drains connected properly
 - Sufficient make-up water supply (minimum 30 PSIG)
 - Instruction manual and warranty certificate left on-site
- Name of person left with: _____

OPERATION CHECK

- Power Supply _____ V _____ PH _____ HZ (machine running)
- Pump, cutter & other motor direction of rotation correct
- Cutter motor amps RLA _____ Actual _____
- Water pump amps RLA _____ Actual _____
- Condenser motor amps (if applicable) _____
- Incoming potable water temperature: _____ °F
- All water distributors in place (visually inspected)
- Make-up water float valve operates properly
- Clear ice Yes No
- Hour meter in control panel connected and operating
- Suction Pressure: End of freeze _____ End of harvest _____
- Discharge Pressure: End of freeze _____ End of harvest _____

Test Cycle	Make-up Water Temp	Freeze Time Min/Sec	Harvest Time Min/Sec	First Ice Out Min/Sec	All Ice Out Min/Sec	Avg. Hole Size	Ice Lb. Per Harvest	Ice Lb. Per Day
#1								
#2								
#3								
#4								

Note: Ice lb. per day can be found by: _____ ice lb. per harvest × 1440
 (freeze time + harvest time)

Remarks: _____

Technician Signature: _____ **End User Signature:** _____

I certify that I have performed all of the above procedures.

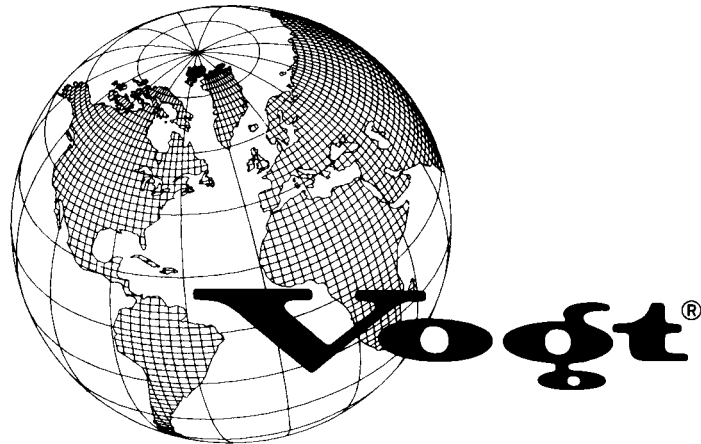

**TUBE ICE[®], LLC, located in
Louisville, Kentucky since 1880.**

Sales - (800) 853-8648

Parts and Service - (502) 635-3000

**Since 1880, Manufacturers of Quality
Tube-Ice[®] Machines**

Vogt[®]
Tube-Ice[®] Machines

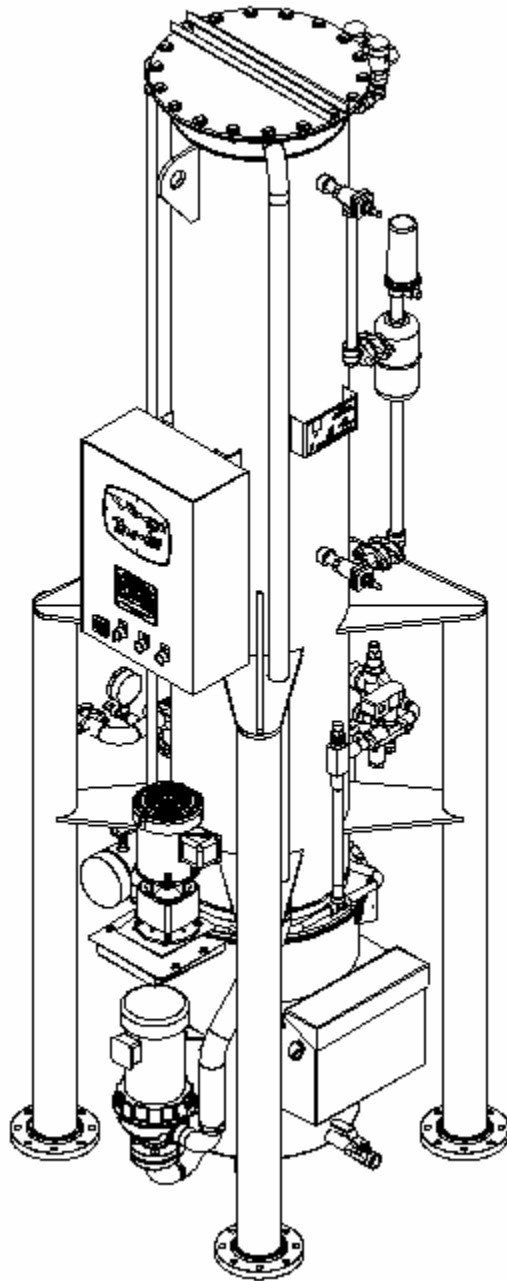

Installation, Service Manual and Parts Catalog #[12A4171M09](#)

P18 Ammonia Lowside Model

TABLE OF CONTENTS

Vogt[®] TUBE-ICE[®] MACHINES Model P18AL

	Page No.
1. INTRODUCTION	
A Brief History Of Our Company	1-1
Vogt Energy-Savings Tube-Ice [®] Machines	1-1
Preview	1-1
Important Safety Notice.....	1-2
Special Precautions To Be Observed When Charging Refrigeration Systems	1-2
Safety Symbols and What They Mean	1-3
Assembly Drawing Model P18AL, FIGURES 1-1, 1-2, 1-3 & 1-4	1-4 to 1-7
2. RECEIPT OF YOUR TUBE-ICE MACHINE	
Inspection	2-1
Description of Machine	2-1
Safety Tags and Labels.....	2-1
Safety Valves.....	2-2
Rated Capacity.....	2-2
Vogt Model Nomenclature	2-2
3. INSTALLING YOUR TUBE-ICE MACHINE	
Machine Room	3-1
Lifting Procedures	3-1
Foundation Layout.....	3-2
Piping and Drain Connections, TABLE 3-1	3-2
Make-up Water In.....	3-3
Water Tank Drain	3-3
Water Tank Overflow	3-3
Water Tank Flush Valve.....	3-3
Receiver, Table 3-2.....	3-3
Suction Pressure Regulator.....	3-4
Compressor Unloading	3-4
Safety Valves.....	3-4
Cooling Tower.....	3-4
Spacing and Connection Diagram, FIGURE 3-1	3-5
Piping Schematic (Dedicated High Side), FIGURE 3-2	3-6
Piping Schematic (Central High Side), FIGURE 3-3	3-7
Wiring and Electrical Connection, FIGURE 3-4	3-8
Control Panel Field Connections, FIGURE 3-5.....	3-9
Electrical Specifications, Table 3-2.....	3-9
Phase Check.....	3-10
Voltage and Current unbalance.....	3-10

TABLE OF CONTENTS

Startup Checklist.....	3-11
4. HOW YOUR TUBE-ICE MACHINE WORKS	
Principle of Operation.....	4-1
Freeze Period.....	4-2
Harvest Period.....	4-2
Piping Nomenclature, Table 4-1.....	4-2
Water Cooled Piping Schematic, FIGURE 4-1.....	4-3
Air-Cooled Piping Schematic, FIGURE 4-2.....	4-4
5. START-UP AND OPERATION	
Refrigeration System Review.....	5-1
Refrigerant Charge.....	5-2
Ammonia Specification By Grade, Table 5-1.....	5-2
Special Precautions.....	5-2
Charging From Tank Truck (dedicated high side only).....	5-2
Charging From Cylinders (dedicated high side only).....	5-3
Charging Operating Characteristics.....	5-4
Start-up Procedure.....	5-5
Thaw Gas Regulating and Suction Gas Regulating Valve Adjustment.....	5-6
Shut-down Procedure.....	5-6
Operating Tips.....	5-7
6. ELECTRICAL CONTROLS & THEIR FUNCTIONS	
General Information.....	6-1
Control Panel (Door Closed), FIGURE 6-1.....	6-2
Control Panel Components and Part Numbers (External), TABLE 6-1.....	6-2
Control Panel (Door Opened), FIGURE 6-2.....	6-3
Control Panel Components and Part Numbers (Internal), TABLE 6-2.....	6-3
Description of Control Panel Component Function, TABLE 6-3.....	6-4
Electrical Schematic All Voltages 50-60 Hz, FIGURE 6-3.....	6-5
7. MAINTENANCE	
Preventive Maintenance.....	7-1
Preventive Maintenance Form.....	7-2
Ice-Making Section.....	7-3
Cleaning Procedure.....	7-3
Water Distribution System.....	7-4
Water Distributors, TABLE 7-1.....	7-4
Average Hole Size in Tube-Ice [®] , TABLE 7-2.....	7-4
Water Tank.....	7-4
Freezer Cover.....	7-4
Other Maintenance Operations.....	7-5
Cutter Gear Reducer.....	7-5
Oil Trap Draining.....	7-5

TABLE OF CONTENTS

Optional Maintenance Operations	7-5
Water Cooled Condenser Cleaning.....	7-5
Cooling Tower/Evaporative Condenser.....	7-6
Compressor.....	7-7
8. TROUBLESHOOTING	
List Of Symptoms.....	8-1
Machine Stopped.....	8-2 & 8-3
Freeze-Up Due To Ice Failing To Discharge.....	8-3
Low Ice Capacity.....	8-4
Poor Ice Quality.....	8-5
High Discharge Pressure (Check Gage Accuracy)	8-5
Low Discharge Pressure (Check Gage Accuracy).....	8-5
High Suction Pressure (Check Gage Accuracy)	8-6
Compressor Running Unloaded During Freeze (Dedicated Compressor Only)	8-6
Compressor Oil Pressure Low (Check Gage Accuracy).....	8-6
Compressor Loosing Oil Excessively	8-6
Machine Short Cycles (Using Freeze Pressure Switch (FPS) Only).....	8-7
High Compressor Discharge Temperature.....	8-7
Suction Line Frosting To Compressor.....	8-7
9. SERVICE OPERATIONS	
Thawing Timer (T), FIGURE 9-1.....	9-1
Freeze Timer (T2).....	9-1
Digital Timer Setting Procedure	9-1
Multi-function Digital Freezer Timer, FIGURE 9-2.....	9-2
Conveyor Timer (T3).....	9-2
Flush Valve Timer (T4).....	9-2
Make-up Water Float Valve (37A).....	9-3
Refrigerant Float Switch (23)	9-3
Hand Expansion Valve (9).....	9-3
Solenoid Valves (18, 25)	9-3
Control Circuit Protection (CB1).....	9-3
Cutter Motor (3) / Gear Reducer (4).....	9-3
Circulating Water Pump	9-4
Pumpdown	
Pumpdown Procedure	9-4
Removal of Ammonia Refrigerant.....	9-5
Refrigerant Leaks	9-5
Non-condensable Gases.....	9-6
Purging Non-condensable Gases	9-6
	Page No.
Purging Procedure (Non-condensable Gases).....	9-6
Draining the Oil Trap	9-7
Oil Trap Draining Procedure	9-7

TABLE OF CONTENTS

Removing Excess Water From Ammonia9-7

Water Removal Procedure9-7

Cutter Motor Removal/Replacement9-9

Cutter Gear Reducer Removal/Replacement9-9

Water Tank Removal9-9

Cutter and Bearing Removal/Installation.....9-10

Cutter/Water Tank Parts List, TABLE 9-19-11

Cutter/Water Tank Assembly, FIGURE 9-3.....9-12

Cutter/Tank Parts, FIGURE 9-49-13

Crushed Ice Production.....9-13

10. TABLES AND CHARTS

P18AL Specifications (60 Hz), TABLE 10-110-2

P18AL Capacity Ratings (7/8" Diameter Ice – 1" Tube), TABLE 10-210-3

P18AL Capacity Ratings (1 1/8" Diameter Ice – 1 1/4" Tube), TABLE 10-310-3

P18AL Capacity Ratings (1 3/8" Diameter Ice – 1 1/2" Tube), TABLE 10-410-4

P18AL Make-up Water Usage, TABLE 10-5.....10-4

P18AL Normal Operating Vitals, TABLE 10-610-5

Recommended Spare Parts List10-5

Temperature - Pressure Chart for Common Refrigerants, TABLE 10-710-6

Conversion Factors: English to Metric, TABLE 10-810-7

Constants, TABLE 10-910-7

11. INDEX

1. Introduction

TUBE ICE[®], LLC

A Brief History Of Our Company Henry Vogt Machine Co. was founded as a small machine shop in Louisville, Kentucky in 1880. In 1938, Vogt built the first Tube-Ice[®] machine and revolutionized the ice-making industry. Our first “sized-ice” machine quickly replaced the old can-ice plants, which required much hard labor and large amounts of floor space for freezing, cutting, and crushing ice by hand.

Today, TUBE ICE[®], LLC carries on the tradition as one of the world’s leading producers of ice-making equipment.

Vogt Energy-Saving Tube-Ice Machines Are Cost Effective Today, Vogt Tube-Ice[®] machines enjoy a well-earned reputation as the most energy efficient, dependable ice-making equipment in the world.

Using as little as one-half to one-third the energy required by competitors’ icemakers, Tube-Ice[®] machines produce the same amount of ice--in restaurants, sports arenas, packing plants, and wholesale operations around the globe--at great savings.

In addition, Tube-Ice[®] machines are renowned for their long life, giving many customers more than 35 years of dependable service. Ask someone who owns one.

Preview All the skill in engineering and fabrication that we have learned in over a century of experience is reflected in the P18AL model Tube-Ice[®] machines. Since Vogt introduced Tube-Ice[®] machines in 1938, the process of making Tube-Ice[®] ice has been widely recognized as the most economical means of production. The machine’s economic and reliable operations have been proven over and over again in a network of varied types of installations throughout the world.

Furnished with your machine is the “Certificate of Test”--the report of operating data that is a record of the unit’s satisfactory operation on our factory test floor. It is evidence of our desire to deliver to you “the finest ice-making unit ever made.”

This manual is designed to assist you in the installation, start-up, and maintenance of your unit. Your Tube-Ice[®] machine will give you a lifetime of service when you install it, maintain it, and service it properly.

Please read your manual carefully before attempting installation, operation, or servicing of this professionally designed piece of equipment.

If you have additional questions, please call your distributor. Also, feel free to phone the factory direct at **(502) 635-3000** or **1-800-853-8648**.

INTRODUCTION

Important Safety Notice. This information is intended for use by individuals possessing adequate backgrounds of electrical, refrigeration and mechanical experience. Any attempt to repair major equipment may result in personal injury and property damage. The manufacturer or seller cannot be responsible for the interpretation of this information, nor can it assume any liability in connection with its use.

Special Precautions To Be Observed When Charging Refrigeration Systems. Only technically qualified persons, experienced and knowledgeable in the handling of anhydrous ammonia refrigerant (R-717) and operation of refrigeration systems, should perform the operations described in this manual. All local, federal, and EPA regulations must be strictly adhered to when handling refrigerants. If a refrigeration system is being charged from refrigerant cylinders, disconnect each cylinder when empty or when the system is fully charged. A gage should be installed in the charging line to indicate refrigerant cylinder pressure. The cylinder may be considered empty of liquid R-717 refrigerant when the gauge pressure is 25 pounds or less, and there is no frost on the cylinder. Close the refrigerant charging valve and cylinder valve before disconnecting the cylinder. Loosen the union in the refrigerant charging line--carefully to avoid unnecessary and illegal release of refrigerant into the atmosphere.

! CAUTION !

<p>Immediately close system charging valve at commencement of defrost or thawing cycle if refrigerant cylinder is connected. Never leave a refrigerant cylinder connected to system except during charging operation. Failure to observe either of these precautions can result in transferring refrigerant from the system to the refrigerant cylinder, over-filling it, and possibly causing the cylinder to rupture because of pressure from expansion of the liquid refrigerant.</p>

! CAUTION !

Always store cylinders containing refrigerant in a cool place. They should never be exposed to temperatures higher than 120°F and should be stored in a manner to prevent abnormal mechanical shocks.

Also, transferring refrigerant from a refrigeration system into a cylinder can be very dangerous and is not recommended.

! CAUTION !

<p>It is not recommended that refrigerant be transferred from a refrigeration system directly into a cylinder. If such a transfer is made, the refrigerant cylinder must be an approved, CLEAN cylinder--free of any contaminants or foreign materials--and must be connected to an approved recovery mechanism with a safety shutoff sensor to assure contents do not exceed net weight specified by cylinder manufacturer or any applicable code requirements.</p>

! CAUTION !

Safety Symbols & What They Mean. Prior to installation or operation of the Tube-Ice® machine, please read this manual. Are you familiar with the installation, start-up, and operation of a Tube-Ice® machine? Before you operate, adjust or service this machine, you should read this manual, understand the operation of this machine, and be aware of possible dangers.

**These Safety Symbols will alert you
when special care is needed.**

Please heed.

! DANGER !
Indicates an immediate hazard and that special precautions are necessary to avoid severe personal injury or death.
! DANGER !

! WARNING !
Indicates a strong possibility of a hazard and that an unsafe practice could result in severe personal injury.
! WARNING !

! CAUTION !
Means hazards or unsafe practices could result in personal injury or product or property damage.
! CAUTION !

INTRODUCTION

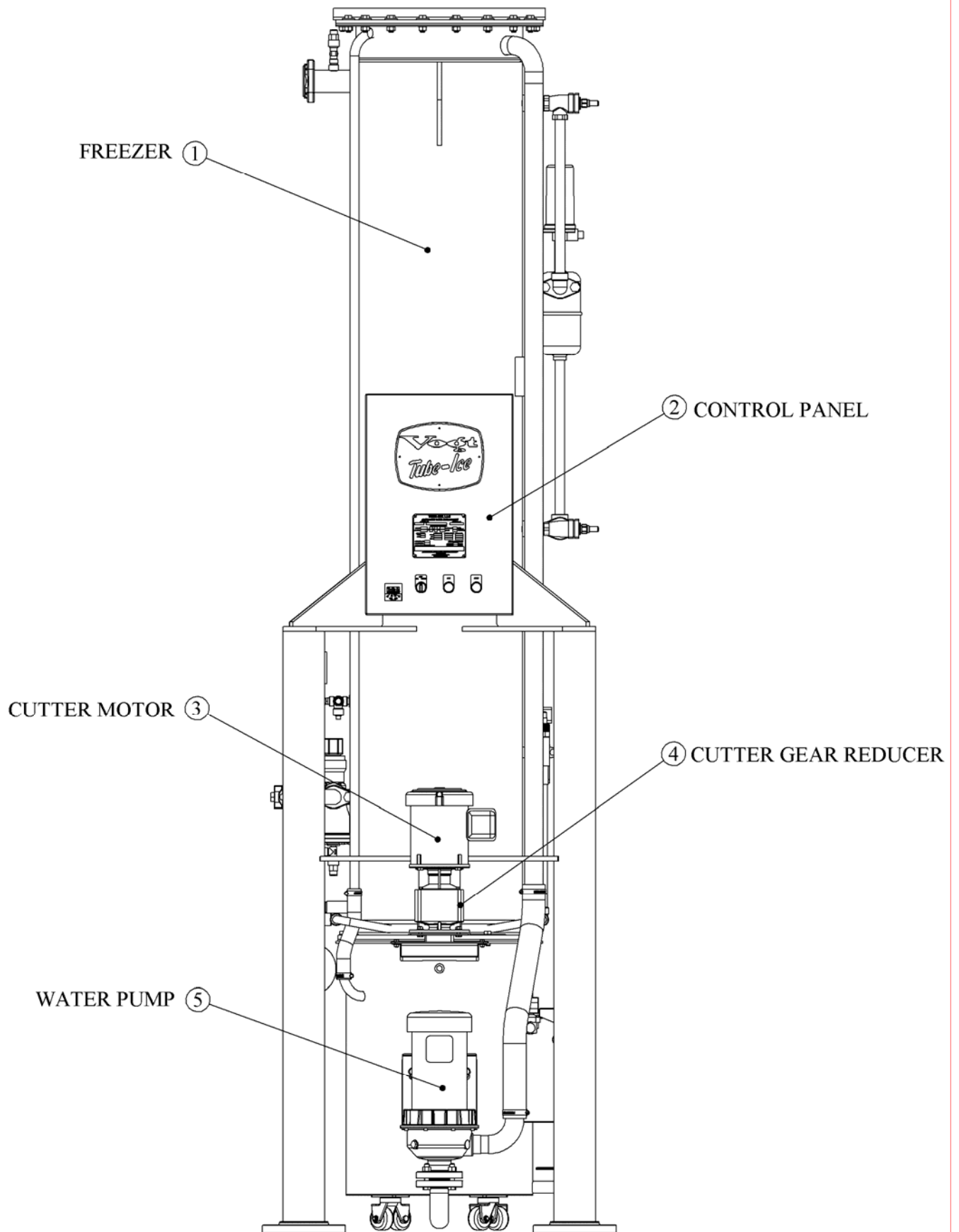

FIGURE 1-1
P18AL Front View

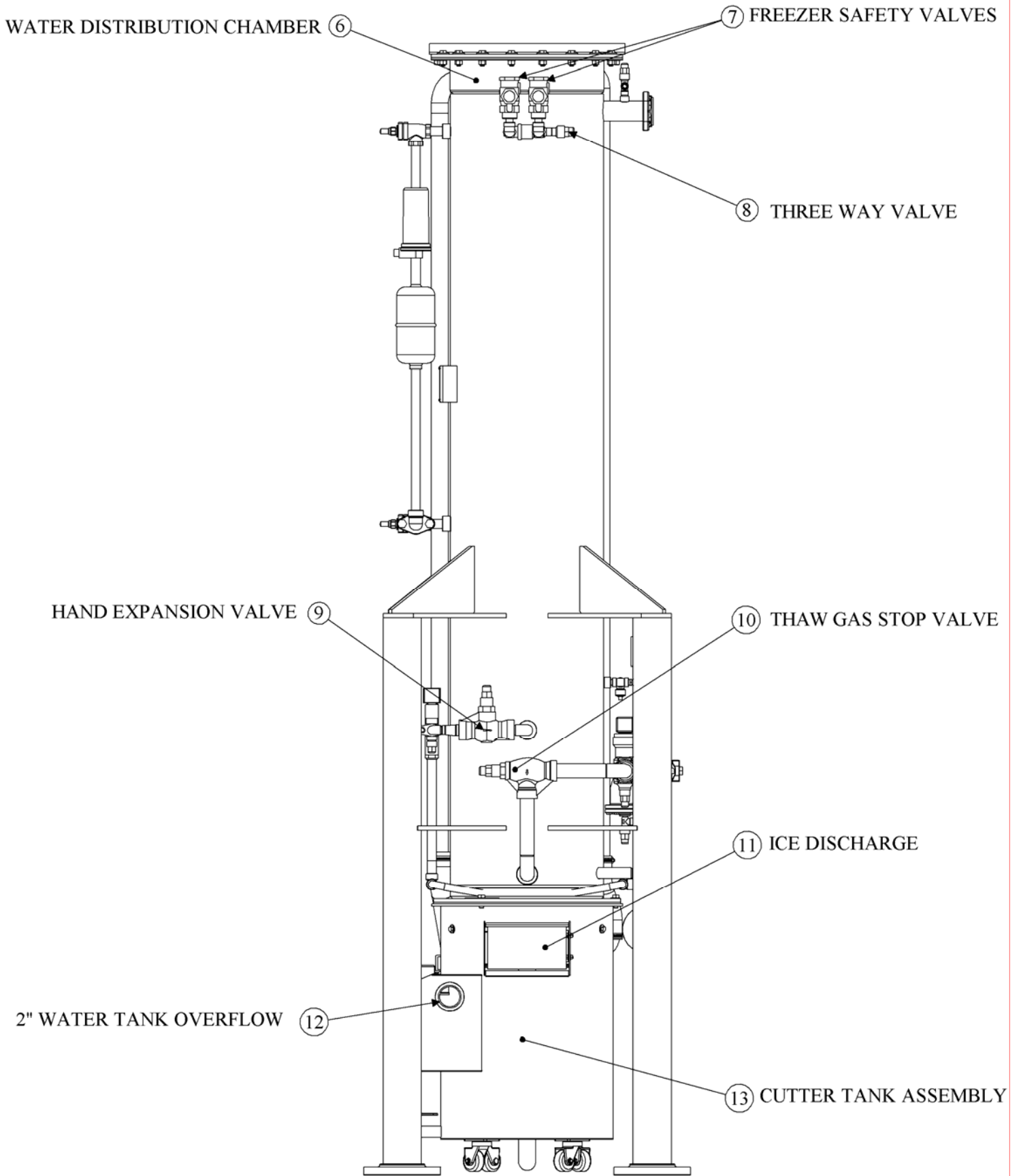

FIGURE 1-2
P18AL Back View

INTRODUCTION

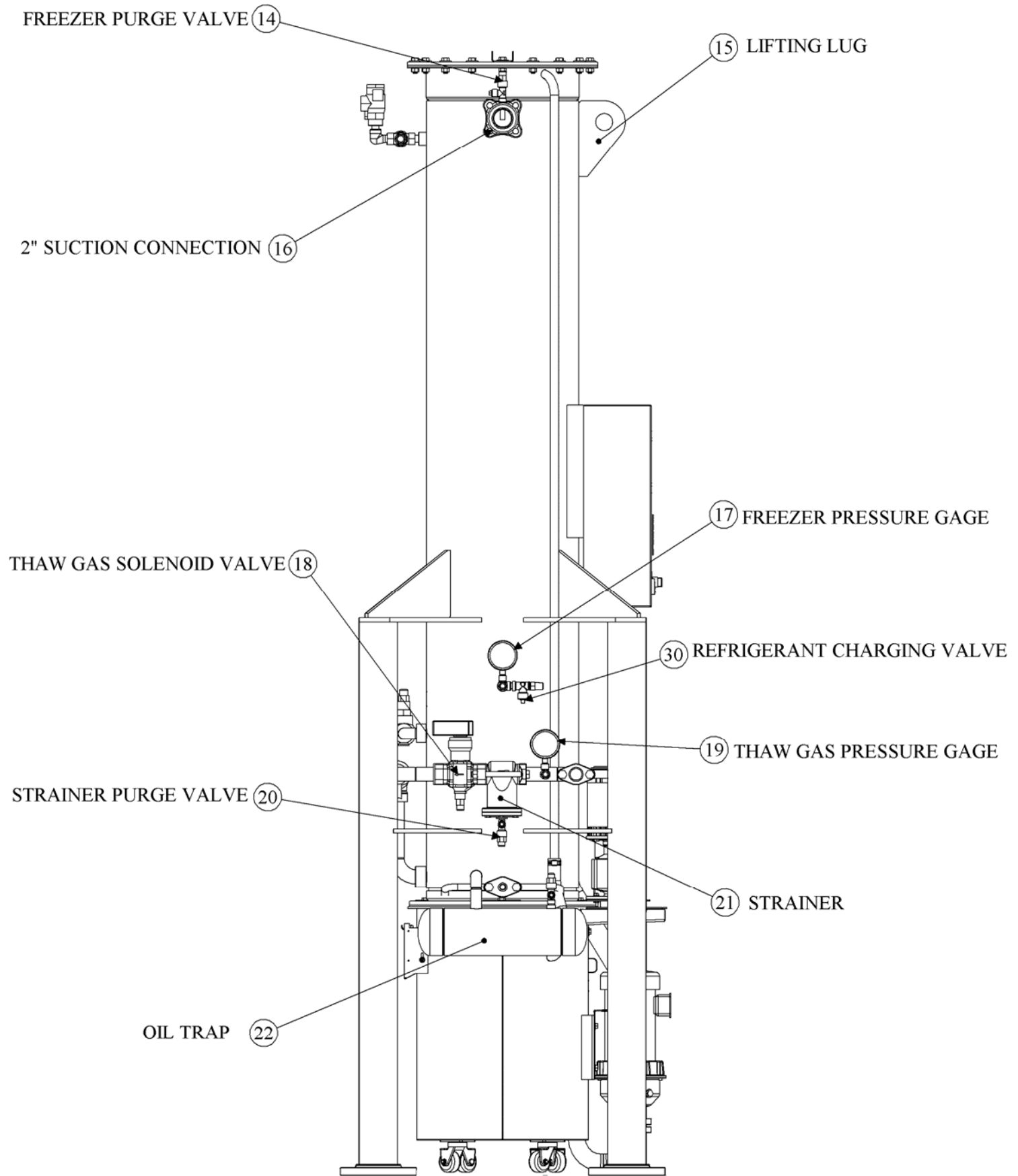

FIGURE 1-3
P18AL Left View

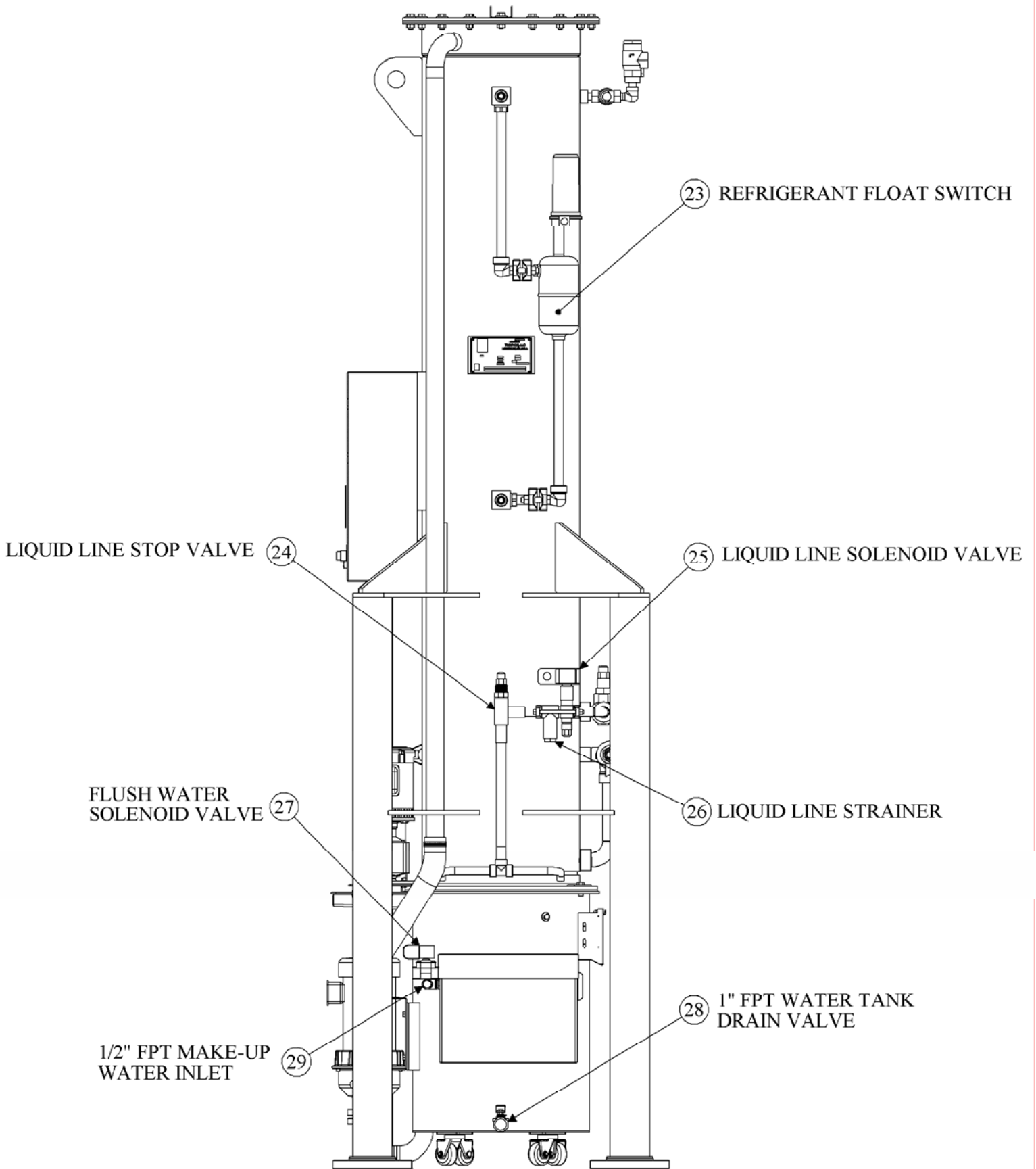

FIGURE 1-4
P18AL Right View

INTRODUCTION

2. Receipt Of Your Tube-Ice Machine

! CAUTION !

Only service personnel experienced in ammonia refrigeration and qualified to work on high amperage electrical equipment should be allowed to install or service this Tube-Ice[®] machine.

Eye protection should be worn by all personnel working on or around the Tube-Ice[®] machine.

It is very important that you are familiar with and adhere to all local, state, and federal, etc. ordinances and laws regarding the handling, storing, and use of anhydrous ammonia.

An approved ammonia mask should be readily available for use in an emergency and all personnel should be aware of its location and proper use.

! CAUTION !

Inspection As soon as you receive your machine, inspect it for any damage. If damage is suspected, note it on the shipper's papers (i.e., the trucker's Bill of Lading). **Immediately** make a separate written request for inspection by the freight line's agent. Any repair work or alteration to the machine without the permission of the Tube-Ice, LLC can void the machine's warranty. You should also notify your Vogt distributor or the factory.

Description Of Machine A Vogt low side Tube-Ice[®] machine is a remote ice producing plant requiring refrigerant suction connection, refrigerant liquid connection, thaw gas connection, make-up water supply, electrical connection, and the proper refrigerant charge.

The machine has been partially factory tested prior to shipment and will require adjustment to meet the high side (condenser unit) operating conditions. See Start-up and Operation for the correct setting of the controls.

The machine is evacuated and charged with nitrogen gas pressure for shipment. This prevents air or moisture from entering the system during transit. There should be a positive pressure (20-25 psig) indicated on the freezer pressure gage when the machine is received. The machine has been cleaned with ice machine cleaner and flushed so that the machine is ready for ice production.

Safety Tags and Labels Be sure to read and adhere to all special tags and labels attached to valves or applied to various areas of the machine. They provide important information necessary for safe and efficient operation of your equipment.

The machine is available in three different tube sizes for producing ice 7/8" OD x 1" long, 1 1/8" OD x 1" long, or 1 3/8" OD x 1" long. The ice is cut to length by a rotating breaker type cutter. Ice can be produced up to 1 1/2" long by modifying the spacers under the adapter plates (see Chapter 9, "Ice Length" for modifying instructions).

RECEIPT OF YOUR TUBE-ICE MACHINE

Safety Valves Two safety pressure relief valves are an integral part of the low-side Tube-Ice[®] machine. Both are located on the top of the freezer. Vent the pressure relief valves to the atmosphere in such a manner as to comply with local and national codes.

Rated Capacity The Tube-Ice[®] machine is rated to produce a given amount of ice when operating under the proper conditions as specified in this manual (see Section 10 for the operating specifications). You should be prepared to handle the ice produced as it is discharged from the machine and move it to your storage or bagging area promptly.

The machine nameplate is located on the front of the control panel. The model number and machine description are located in the top left hand corner. The following figure can be used to verify that the correct model has been received.

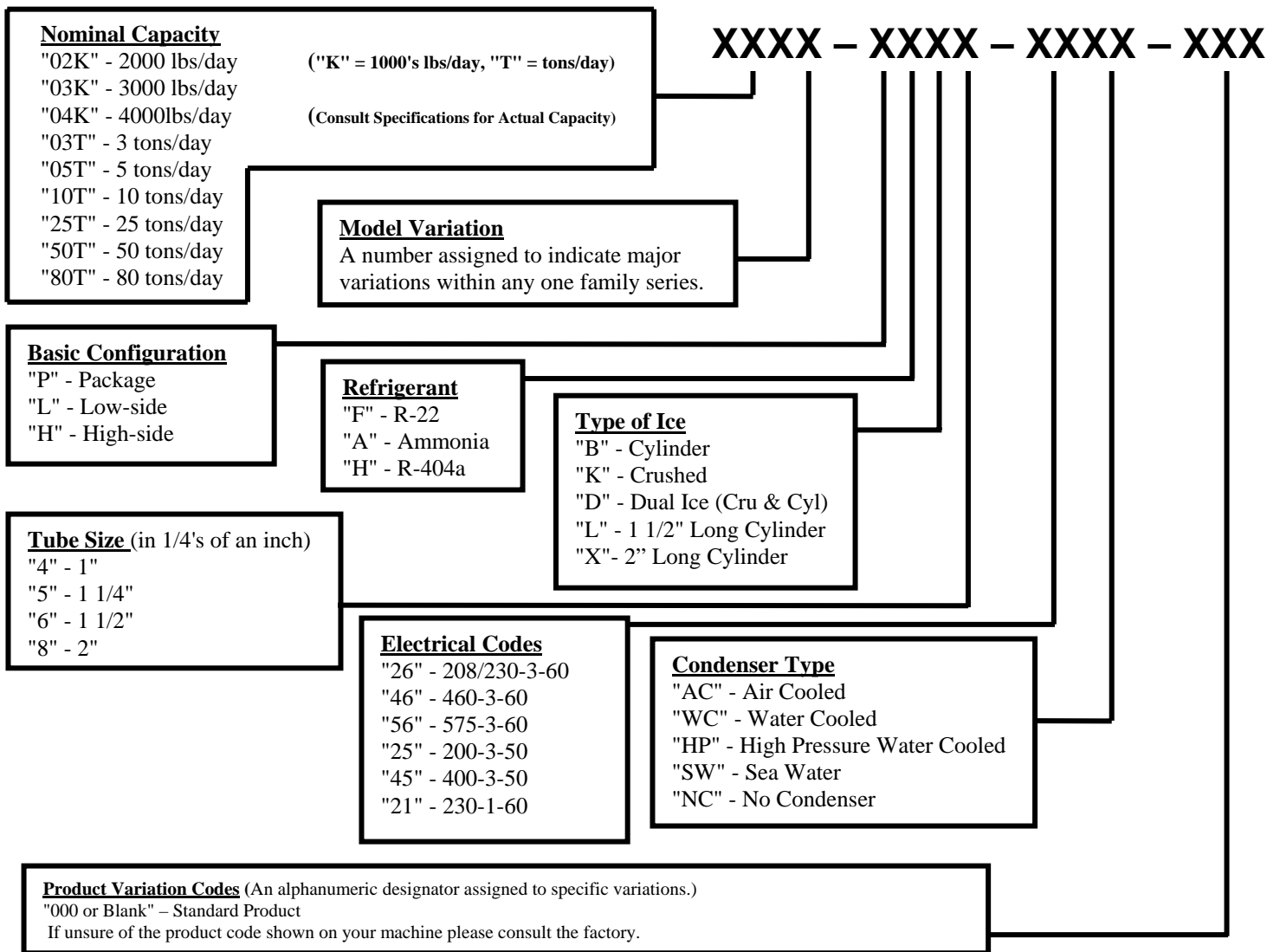

**Figure 2-1
 Vogt Model Nomenclature**

3. Installing Your Tube-Ice® Machine

! WARNING !

Only service personnel experienced and certified in refrigeration and qualified to work with high voltage electrical equipment should be allowed to install or work on this Tube-Ice® machine.

! WARNING !

Important Notice.

The Warranty Registration / Start-Up Form must be completed and returned to Vogt Tube-Ice® to initiate and assure a full warranty. A postage paid envelope is provided or you may fax the report to 800-770-8648.

Machine Room The machine must be located inside a suitable building and must not be subjected to ambient temperatures below 50°F (10°C) or above 110°F (43.3°C). Heat from other sources (sunlight, furnaces, condenser, etc.) and unusual air current may affect the operation of the machine and should be avoided.

The electrical components of the Tube-Ice® machine are rated NEMA 1. **The machine should not be located in a hazardous area or sprayed with water.** The machine should be installed in an area where water will not stand but will readily drain away from the machine. See Space Diagram for clearances and utility connections, FIGURE 3-1.

Lifting Procedures

! CAUTION !

**The approximate shipping weight of the machine is 2,300 pounds.
Always use equipment with adequate load carrying capacity.**

**The Tube-Ice® machine is top heavy.
Lift from the top to avoid tipping.**

! CAUTION !

The machine body has a lifting lug on the top for an eyebolt and hook to be used for lifting purposes if desired. A lifting lug should be used whenever possible. If a forklift is used, make sure its capacity is sufficient. The machine needs to be lifted from the top to prevent tipping.

Do not lift the machine using the water box flange on the top of the freezer. The water box flange is not designed to carry the machine load. The flange could fail or bend causing damage or personal injury.

INSTALLING YOUR TUBE-ICE® MACHINE

Foundation Layout

! CAUTION !
The approximate machine operating weight is 3,000 pounds.
! CAUTION !

The machine foundation should be constructed from concrete or similar material in accordance with all local and federal OSHA codes and building regulations. The minimum required foundation size is shown in Figure 3-1. The foundations height will vary depending on the auxiliary equipment selected by the customer to transport ice to a bin or hopper. Adequate space should be allowed for removal of the water tank and servicing operations such as cleaning the water distributors.

Figure 3-1 indicates minimum mounting requirements. Contact your local distributor for seismic anchoring requirements in your area. Additional bracing may need to be added to the top of the machine mounted to the lifting lug to meet local codes.

Piping and Drain Connections

Figure 3-1 (Water Connections and Refrigerant Connections) shows locations and sizes for all connections on lowside.

! CAUTION !
External shut-off valves must be provided in the water inlet lines. The minimum inlet water pressure for satisfactory operation of the machine is 30 psig. The maximum allowable pressure is 100 psig.
! CAUTION !

Make-up Water In	Water Tank Drain*	Water Tank Overflow	Water Tank Flush Valve	Suction Connection**	Liquid Connection***	Thaw Gas Connection***
1/2" FPT	1" FPT	2" FPT	3/4" FPT	2" Flange	3/4" Flange	1 1/4" Flange

* The water tank drain connection must be extended to an open drain or sump, arranged for visible discharge.

** Mating 4 bolt flange supplied with machine.

*** Mating 2 bolt flange supplied with machine.

**TABLE 3-1
Water Supply and Drain Sizes**

! CAUTION !
These lines must NOT be connected into a pressure tight common header due to the possibility that warm condenser water may back up into the water tank. The condenser water outlet MUST be piped separately to the drain.
! CAUTION !

INSTALLING YOUR TUBE-ICE® MACHINE

Make-Up Water In. The water required for ice making must be potable water, safe for human consumption, and should be of the highest quality available. The best way to determine water quality is to have a complete water quality analysis by a qualified laboratory.

It is advisable to install a particle filter in the make-up and flushing water lines to trap dirt, sand, rust, or other solid particles prior to entering the water tank and contaminating the ice. Be sure to size the filter large enough to meet the water demands of 15 GPM (peak flow), allowing for a restriction through the filter as it traps these particles. Minimum required supply pressure is 30 psig.

Water Tank Drain. This valve and connection is for the purpose of flushing and draining the water tank of impurities, foreign material and cleaning chemicals used during servicing. It should be piped to an open drain or sump for visible discharge. It can be tied in with the overflow line but no others.

Water Tank Overflow. A 2" FPT connection on the side of the water tank is provided to carry away overflow water during the thawing (harvest cycle). This water contains ice fines accumulated during harvesting and dissolved solids accumulated during the freezing cycle. **Do not reduce the size of this line.** Three inches is needed to provide sufficient area for ice fines to be flushed out, especially if the incoming flushing water is 55°F (13°C) or below. This overflow line should not tie in with any other drain line except the water tank drain.

Unless water quality is superior, do not discharge the overflow water to the cooling tower system. This water contains additional dissolved solids left from the ice making process and can lead to excessive condenser fouling or cooling tower chemical usage. It is recommended that a heat exchanger be used in place of direct contact with condenser water.

Water Tank Flush Valve. Flushing water (blowdown) is necessary to melt ice fines and flush dissolved solids from the water tank during the thawing (harvest) cycle. This function is important and helps to maintain good ice quality. If water quality is superior, this blowdown can be reduced by installing a smaller orifice in the flushing outlet elbow. Make sure there is enough flushing water to prevent the accumulation of excessive ice fines in the tank.

If make-up and flushing water are from the same source, they can be connected by a common line to the machine.

Receiver The receiver used to supply hot thaw gas must be sized adequately to provide sufficient thaw gas. Table 3-2 shows the volume required to hold the refrigeration charge of the freezer and the hot gas required for the thaw cycle. It is recommended that a heating coil be installed in the receiver to assure that the liquid ammonia is at saturated temperature at the start of each thaw period.

Note: Additional storage volume may be required for the interconnecting piping. Add volume of interconnecting piping to the values shown in Table 3-2

RECEIVER VOLUME (Cubic Feet)		
MODEL	With Heating Coil	With out Heating Coil
P18AL	10	15

TABLE 3-2
Receiver Volume Requirements

INSTALLING YOUR TUBE-ICE® MACHINE

Suction Pressure Regulator When a P18AL is attached to a central system a pressure regulator will be required (see Figures 3-3 for location). This regulator (usually furnished by the purchaser) must be a combination back pressure regulating and stop type valve. The usual minimum pressure drop across this type valve is 2 psig, therefore the valve must be set to maintain a freezer pressure at least 2 psi above the maximum general suction pressure.

Compressor Unloading When a P18AL is attached to a dedicated compressor system unloading of the compressor will be required. A minimum compressor unloading during the harvest cycle is 66%. If the compressor can not be unloaded then a hot gas bypass to the suction line must be installed.

Safety Valves Two safety pressure relief valves are an integral part of the packaged Tube-Ice® machine. They are located on the suction accumulator of the freezer. Vent each of the pressure relief valves to the atmosphere in such a manner as to comply with local and national codes. Refer to the International Institute of Ammonia Refrigeration (IIR) standard for specific requirements and instructions.

Cooling Tower When selecting a cooling tower, careful attention must be given to operating wet bulb conditions. It is advisable to check with your local cooling tower distributor for their recommendations based on actual operating conditions in your area. An average wet-bulb of 78°F is typical in the U.S. but many localities have design wet-bulbs as low as 72°F or as high as 82°F.

The cooling tower water pump must be capable of delivering the required volume of water through the condenser. Due to cooling tower location and pressure drop through water lines and water regulating valves, the pump must be sized for each installation. Refer to TABLE 11-4 for condenser water requirements. The water piping for the cooling tower and the installation of the pump must be in accordance with the manufacturer's instructions.

Proper water treatment for the prevention of mineral and foreign matter accumulation in the condenser or cooling tower is recommended. A water analysis should be obtained to determine the proper chemicals to use.

The condenser water pump should be sized on GPM required for condenser at 80 ft. total discharge head for a typical installation. However, due to cooling tower location and pressure drop through water lines, the water pump should be sized for each installation.

If the condenser inlet water temperature is expected to be below 75°F/24°C, a water regulating valve should be installed in the condenser water inlet line and adjusted to maintain a head pressure of not less than 175 psig.

INSTALLING YOUR TUBE-ICE® MACHINE

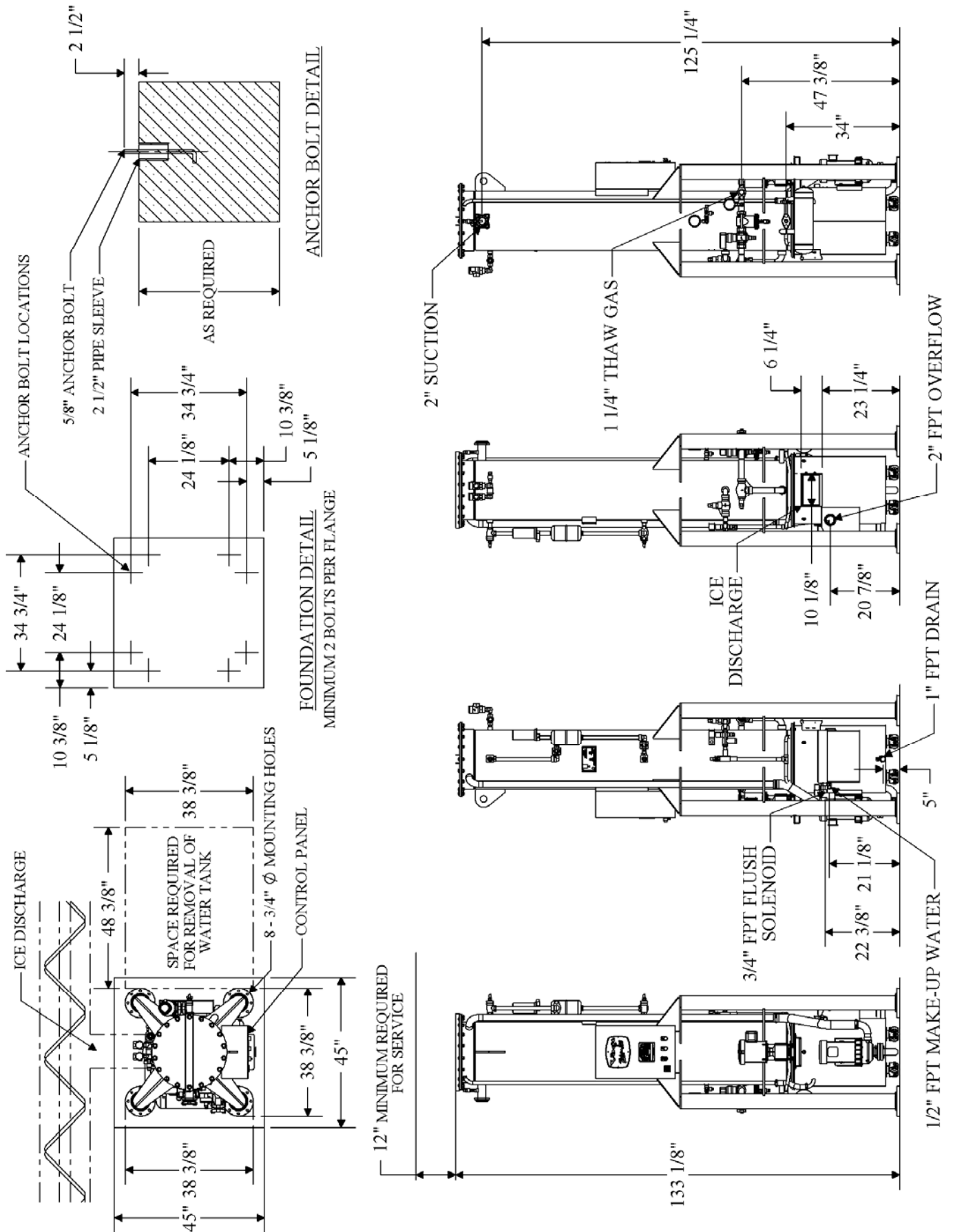

FIGURE 3-1
Spacing and Connection Diagram

INSTALLING YOUR TUBE-ICE® MACHINE

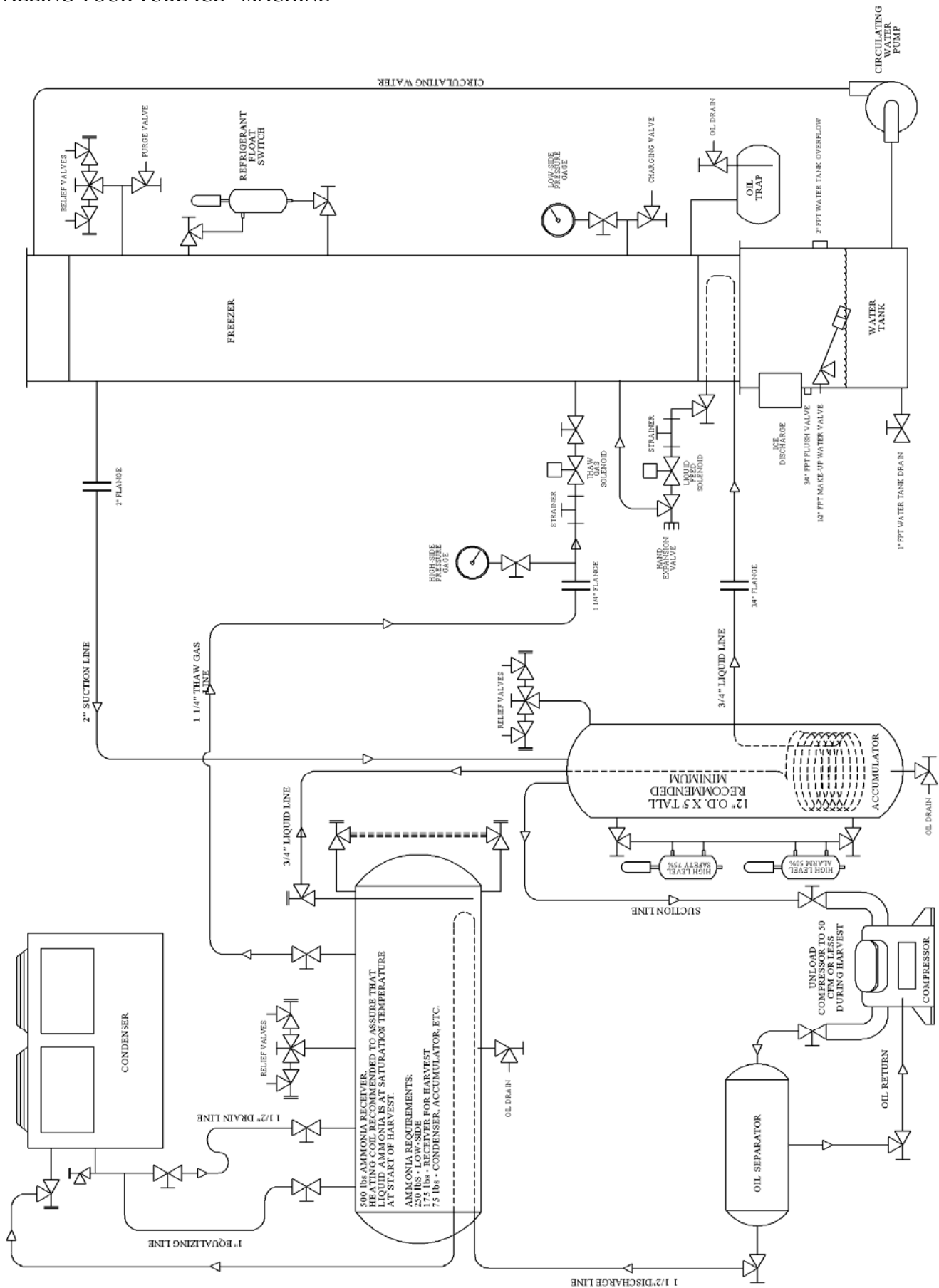

FIGURE 3-2
Piping Schematic (Dedicated High Side)

INSTALLING YOUR TUBE-ICE® MACHINE

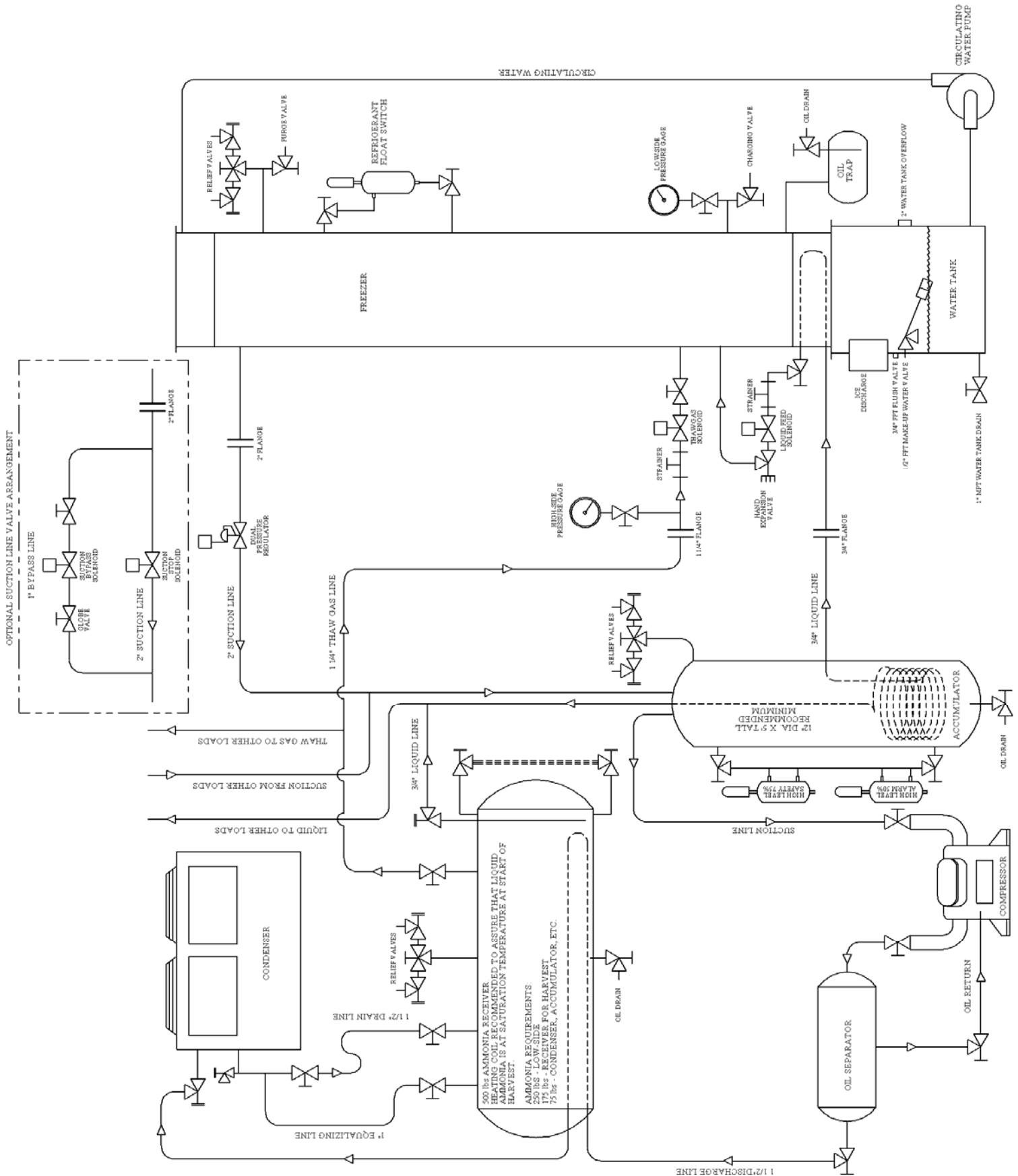

FIGURE 3-3
Piping Schematic (Central High Side)

INSTALLING YOUR TUBE-ICE[®] MACHINE

Wiring and Electrical Connection

! WARNING !
Only service personnel experienced in refrigeration and qualified to work with high voltage electrical equipment should be allowed to install or work on the Tube-Ice[®] machine.
! WARNING !

Refer to TABLE 3-2 to properly size wiring connections. A fused disconnect must be provided near the Tube-Ice[®] machine. Connect 3 phase power to terminals L1, L2, L3 for operation of the Tube-Ice[®] machine and its controls. Rotation checking of cutter motor and water pump is required (see following section). Also, if one leg of the 3 phase power is higher or lower (“Wild”), then it should be connected to terminal #L2. Connect the “Ground” wire to the “Ground” lug provided.

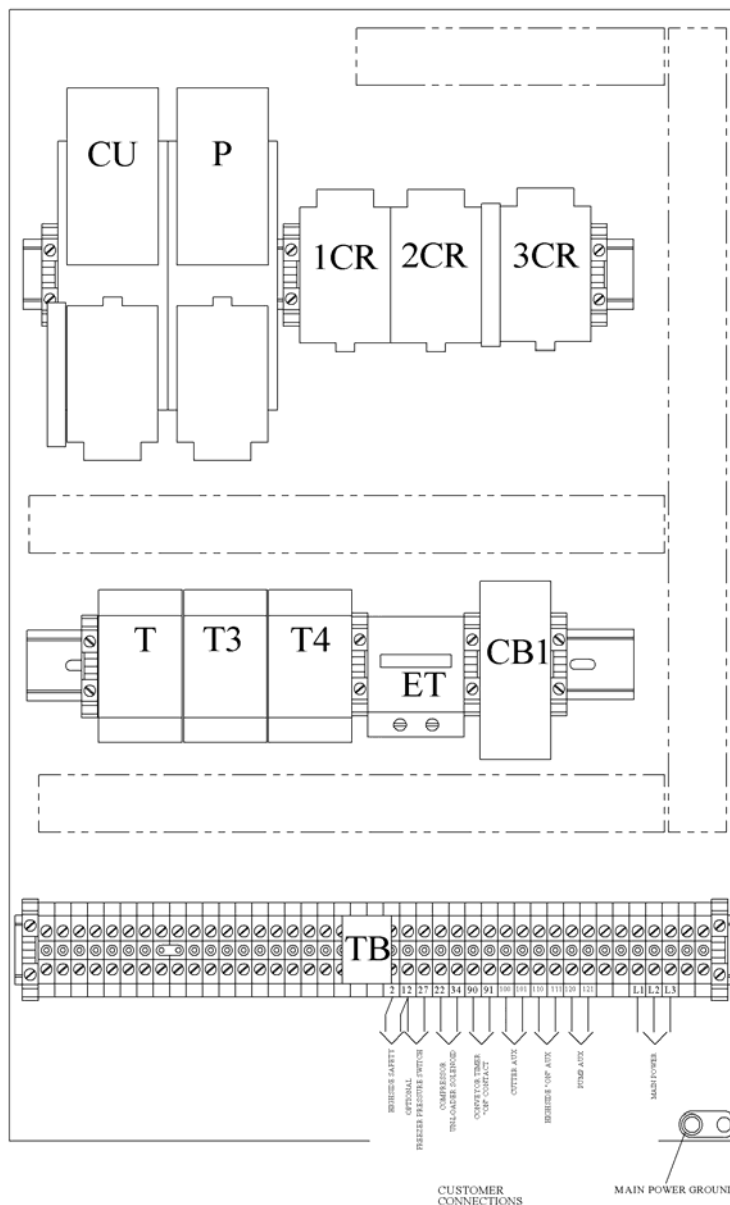

FIGURE 3-4
Control Panel Field Connections

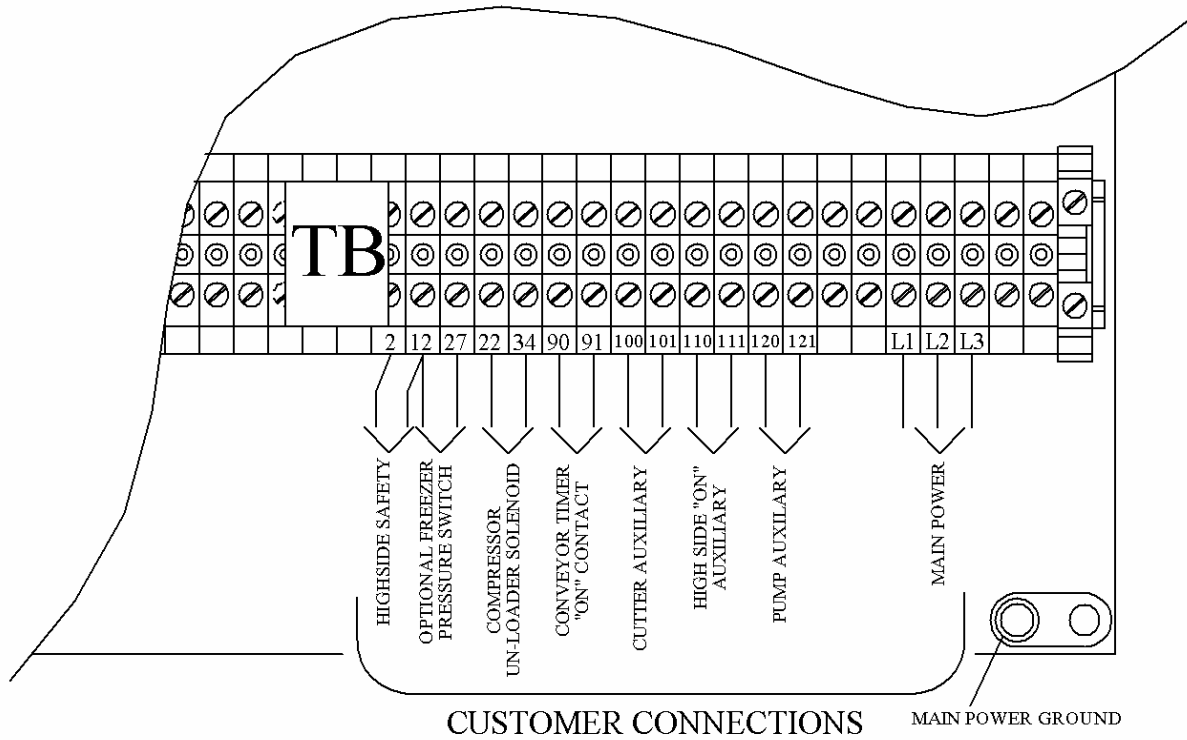

FIGURE 3-5
Control Panel Field Connections (Detail)

Standard Voltages	F.L.A.	Minimum Ampacity	Maximum Fuse
208/230, 3ph, 60 Hz	8.3	9.8	10
460, 3ph, 60 Hz	4.0	4.6	5
220, 3ph, 50 Hz	8.3	9.8	10
400, 3ph, 50 Hz	4.4	5.1	10

TABLE 3-2
Electrical Specifications

Note: Refer to Chapter 6 for a wiring schematic and electrical component layout and description.

INSTALLING YOUR TUBE-ICE® MACHINE

Phase Check

! CAUTION !
DO NOT attempt to start machine without priming pump and insuring proper rotation of both cutter and pump.
! CAUTION !

Cutter and pump motor rotation are factory synchronized but **must** be checked at installation. For ice production, the cutter disc, as viewed at the ice discharge opening should turn from left to right (crushed rotation should be from right to left). The pump rotation should match the marking on the pump housing. The pump will need to be primed by starting the machine in the clean mode and allowing it to run for several minutes. To change direction of rotation for both, cutter and pump, disconnect power and reverse L1 and L3 (incoming power wires) at the compressor motor contactor.

Voltage Unbalance Voltage unbalance can cause motors to overheat and fail.

The maximum voltage unbalance between any two legs should be no greater than 2%.

Example: Supply Voltage = 230-3-60

Voltage Readings:	AB = 220 Volts	
	BC = 225 Volts	Average = $(220 + 225 + 227)/3 = 224$ Volts
	AC = 227 Volts	

(AB) $224 - 220 = 4$ Volts (Highest Deviation)

(BC) $225 - 224 = 1$ Volts

(AC) $227 - 224 = 3$ Volts

% Voltage Unbalance = $100 \times (4/224) = 1.78\%$ "Acceptable"

Important: If the supply voltage phase unbalance is more the 2%, contact your local electric utility company.

Current Unbalance Voltage unbalance will cause a current unbalance, but a current unbalance does not necessarily mean that a voltage unbalance exists. A loose terminal connection or a buildup of dirt or carbon on one set of contacts would cause a higher resistance on that leg than on the other two legs. Current follows the path of least resistance, therefore if terminal connection L1 is loose or dirty, L2 and/or L3 will have higher current. Higher current causes more heat to be generated in the motor windings.

The maximum acceptable current unbalance is 10%.

Example:

Current Readings:	L1 = 96 Amps	
	L2 = 91 Amps	Average = $(96 + 91 + 98)/3 = 95$ Amps
	L3 = 98 Amps	

(L1) $96 - 95 = 1$ Amps

(L2) $95 - 91 = 4$ Amps (Highest Deviation)

(L3) $98 - 95 = 3$ Amps

% Current Unbalance = $100 \times (4/95) = 4.2\%$ "Acceptable"

Startup Checklist**! IMPORTANT !**

**Be sure to follow the wiring schematic when incorporating overloads.
This is necessary to provide proper
protection for the Tube-Ice® machine and its component parts.**

! IMPORTANT !

Installation Review: A Checklist. Make a visual check to be sure these steps have been taken BEFORE continuing.

CHECK: ____ PRIOR TO OPENING VALVES, check all joints for leaks which may have developed during shipment. (NOTE: the machine was shipped with a positive pressure of 20-25 PSIG, verify on the freezer pressure gage.)

CHECK: ____ The system is properly evacuated to 500 microns.

CHECK: ____ All refrigerant piping, water supply and drain connections for conformity to requirements stipulated in this manual and properly connected to inlets and outlets.

CHECK: ____ Electrical supply for proper size of fuses and for compliance to local and national codes. See the machine nameplate for minimum circuit ampacity and maximum fuse size.

CHECK: ____ All field installed equipment (augers, conveyors, cooling towers, bin level controls, etc.) for proper installation.

CHECK: ____ The applicable portion of the warranty registration/start-up report for proper completion.

CHECK: ____ Cutter gear reducer oil level oil should run out of side pipe plug when removed.

CHECK: ____ The water distributors at top of freezer to make sure they are all in position

! CAUTION !

**The compressor crankcase heater should be energized for a minimum of
four hours and the oil temperature should be 100-110°F
before attempting to start the compressor.**

! CAUTION !

4. How Your Tube-Ice® Machine Works

Principle Of Operation

For a detailed description of the functions of each control panel component, see Section 6. Operation of the machine is controlled by “Clean/Off/Ice”, “Start” and “Stop” switches located in the control panel of the freezing unit. Automatic operation is controlled by the freeze timer or an optional ice bin thermostat which will automatically stop and start the ice maker by the level of the ice in the storage bin. The control wiring is arranged so that the unit will stop only upon the completion of a thawing period whether by action of the “Clean/Off/Ice” switch in the “Off” position, by the completion of a timed cycle or by the ice bin thermostat.

The “Clean/Off/Ice” switch must always be set in the “Ice” position during normal ice-making operation. It is set in the “Clean” position only when the equipment is to be cleaned as outlined in the “Cleaning Procedure”, Section 7 and instructions attached to the machine.

If it should become necessary to instantly stop the machine, push the “Stop” button. To restart the machine, push the “Start” button.

FIGURES 4-1 & 4-2 illustrate the piping diagram of the refrigerant and water circuits of the Tube-Ice® machines with numbers for easy reference. Throughout this manual, the numbers you see in parentheses refer to the numbers in this piping schematic.

The freezer (1) is a shell and tube-type vessel. During the freezing period, water is constantly recirculated through the vertical tubes of the freezer by a centrifugal pump (5). Make-up water is maintained by a float valve (29) in the water tank (13). The refrigerant float switch (23) opens and closes the liquid line solenoid valve (25), sometimes referred to as the “A” valve, is open and solenoid valve (18), sometimes referred to as the “D” valve, is closed.

Refrigerant gas from the top of the freezer (1) passes through the suction accumulator, and to the compressor. Here the cool gas is compressed to a high temperature, high pressure gas which discharges through the oil separator and into the condenser. In the condenser, heat is removed and the gas is condensed to a high temperature, high pressure liquid. The high pressure liquid goes through the accumulator boil out coil where it gives up heat to the suction gas for compressor protection. In addition, this liquid is subcooled and carried to the Freezer (1). Liquid refrigerant from the accumulator flows through the thawing chamber of the freezer, the liquid line stop valve (24), the “A” liquid feed valve (25) and then the hand expansion valve (9). The float switch (23) is wired to the “A” solenoid valve (25). The float switch energizes and de-energizes the “A” solenoid in response to the level of refrigerant in the freezer. The cold liquid refrigerant enters the freezer where it absorbs heat from the circulating water. This cool gas is pulled out of the freezer at the suction outlet thereby completing the circuit.

HOW YOUR TUBE-ICE MACHINE WORKS

The freezing period is completed by action of the freeze timer in the control panel (or an optional freezer pressure switch). The water pump (5) is stopped and solenoid valve “A” (25) is closed. The thawing period then begins. The thaw gas solenoid valve (18), sometimes referred to as the “D” valve, is opened, the cutter motor (3) is started and the harvest timer (T) is activated. Warm gas from the receiver is discharged into the freezer through valve (18), thereby slightly thawing the outer edge of the ice which drops on the rotating cutter for sizing. See “Freezer Period and Harvest Period” for more detailed description of operation.

Freeze Period. The Tube-Ice[®] is frozen inside the stainless steel tubes in the freezer (1) by the direct application of refrigerant to the shell side (outside) of the tubes. The ice is produced from constantly recirculating water during the freeze period. As the ice thickness increases, the freezer suction pressure decreases. At a set time, the freeze timer initiates the harvest period. The harvest period may also be controlled by means of a freezer pressure switch that can be adjusted to get the correct thickness of ice (this is an optional control device – consult the factory for information).

Harvest Period. When the freeze timer (T2) contact closes, a control relay (1CR) is energized. The “1CR” relay stops the water pump and starts the cutter motor. The “A” solenoid valve (25) closes, the “D” solenoid valve (18) opens and the thaw timer (T) is energized. As the ice releases and drops through the rotating cutter and onto the cutter disc, it is discharged through the side opening of the water tank. The harvest timer (T) is to be set for the time required to discharge all the ice plus 30 seconds longer (usually 2 to 2 1/2 minutes).

! CAUTION !
Make sure all the ice clears the freezer with at least 30 seconds to spare before the next freeze period begins. This is to prevent refreezing.
! CAUTION !

1	Freezer	16	Suction Connection, 2” Flange
2	Control Panel	17	Freezer Pressure Gage
3	Cutter Motor	18	Thaw Gas Solenoid Valve
4	Cutter Gear Reducer	19	Thaw Gas Pressure Gage
5	Water Pump	20	Strainer Purge Valve
6	Water Distribution Chamber	21	Strainer
7	Freezer Safety Valves	22	Oil Trap
8	Three Way Valve	23	Refrigerant Float Switch
9	Hand Expansion Valve	24	Liquid Line Stop Valve
10	Thaw Gas Stop Valve	25	Liquid Line Solenoid
11	Ice Discharge	26	Liquid Line Strainer
12	Water Tank Overflow, 2” FPT	27	Flush Water Solenoid Valve
13	Cutter/Tank Assembly	28	Water Tank Drain Valve, 1” FPT
14	Freezer Purge Valve	29	Make-up Water Inlet Valve, ½” FPT
15	Lifting Lug	30	Refrigerant Charging Valve

Piping Nomenclature
TABLE 4-1

HOW YOUR TUBE-ICE MACHINE WORKS

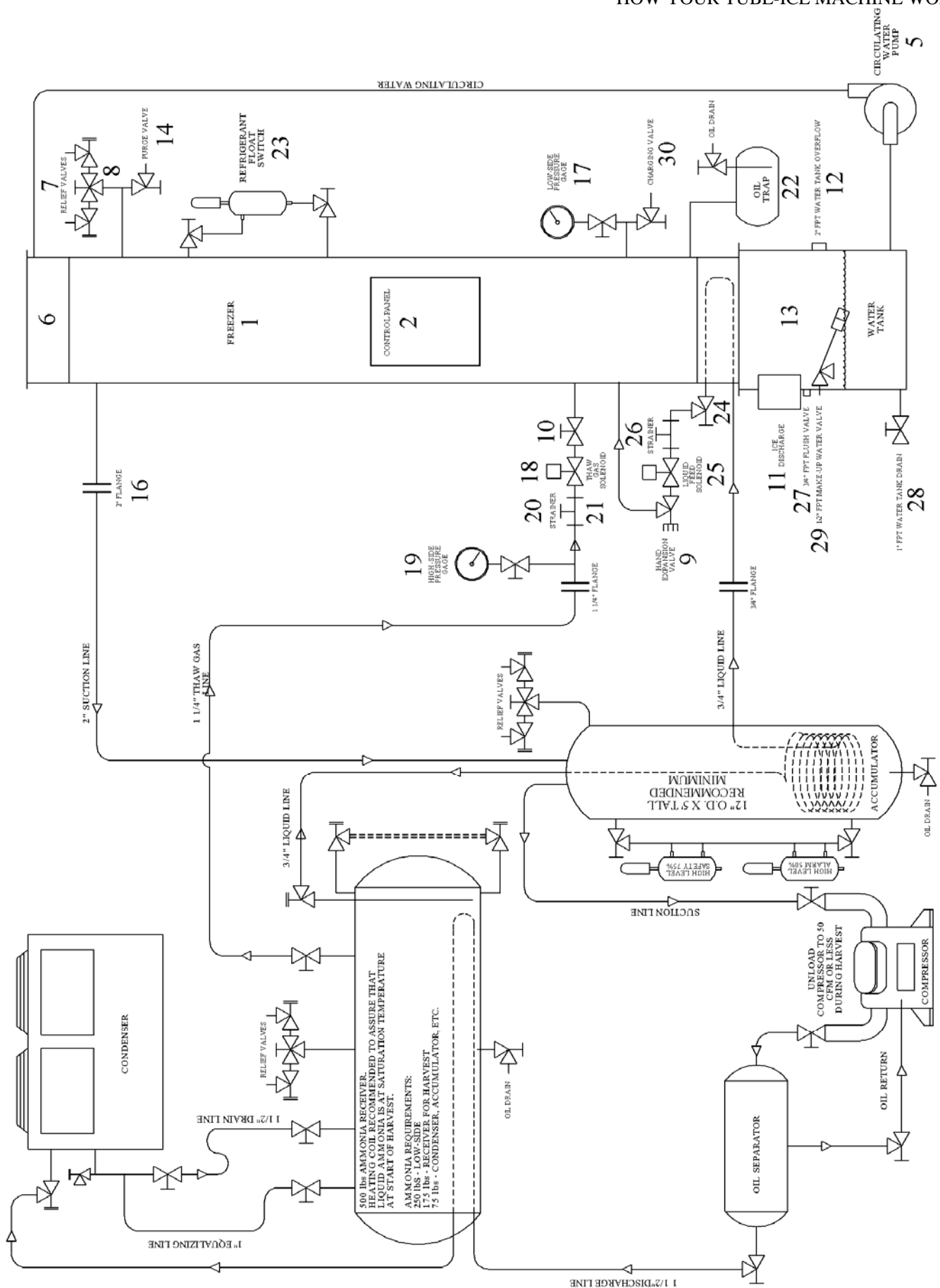

FIGURE 4-1
P18AL Piping Schematic (Dedicated High-Side)

HOW YOUR TUBE-ICE MACHINE WORKS

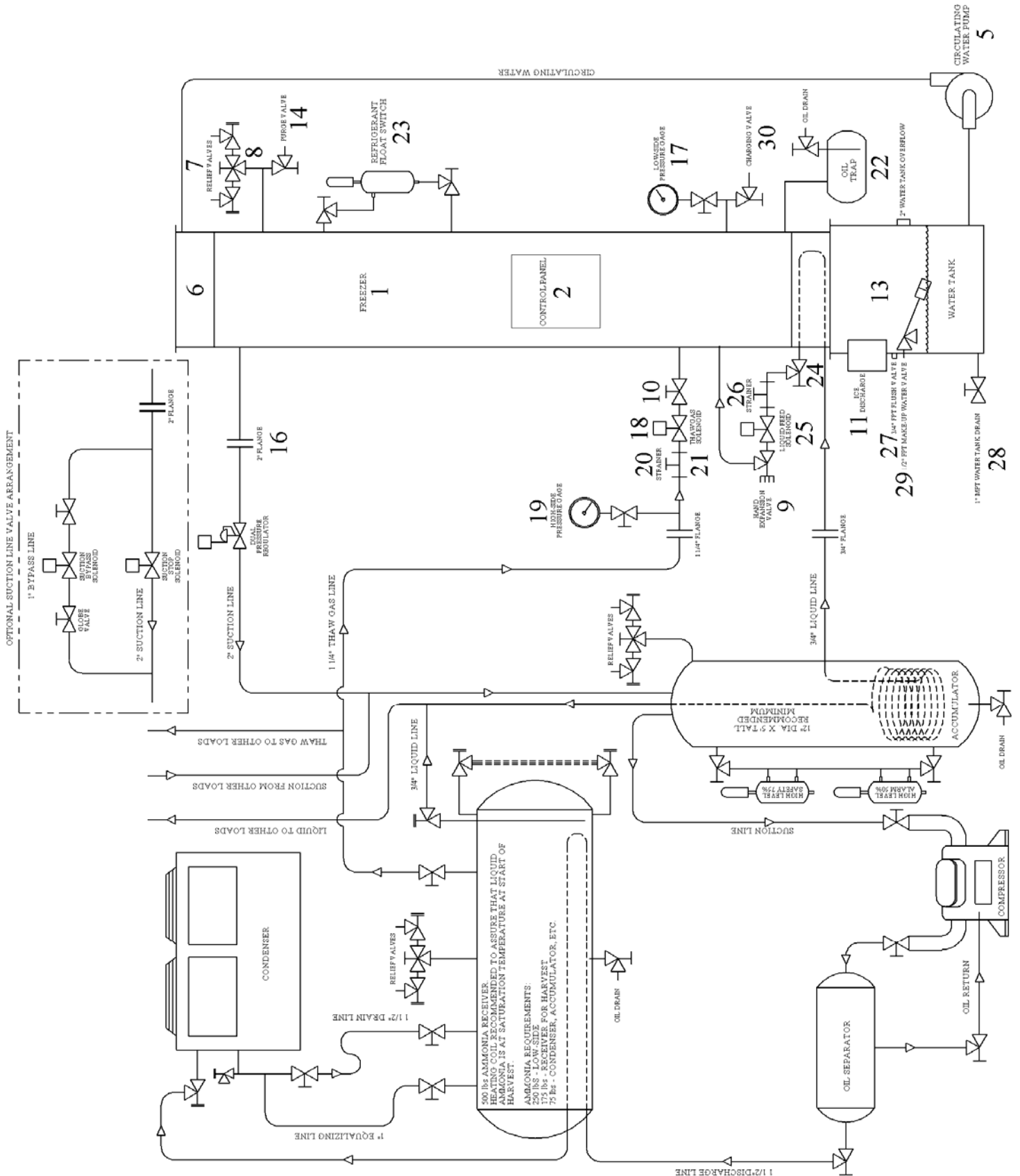

FIGURE 4-2
P18AL Piping Schematic (Central System)

5. Start-Up and Operation

Refrigeration System Review The refrigeration system uses anhydrous ammonia (R-717) refrigerant. Following the piping schematic (Figure 3-2 or 3-3), you will see that during the machine's freeze cycle, the compressor discharge gas goes through the oil separator to remove any oil present in the discharge gas and return the oil to the compressor crankcase. It is then discharged into the condenser and condensed into a liquid by the removal of heat by water passing through the condenser tubes. A reservoir of liquid R-717 (approximately 175 lbs) is accumulated in the receiver and is required for thawing purposes (see Table 3-2). Liquid from the receiver flows through the strainer to the "A" solenoid valve (25) which opens and closes by action of the low side float switch (23). The liquid is then expanded through the hand expansion valve (9) and into the evaporator (1) (freezer). The cold wet R-717 refrigerant floods the evaporator and is in contact with the outside of the ice making tubes which water is being circulated through. The heat contained in the water passes through the wall of the tubes, lowering the temperature of the water causing it to freeze and form a long tube of ice that adheres to the inside of freezer tubes. Since the purest water freezes first, the circulating water continues to wash the dissolved solids down into the sump area of the water tank. The flushing valve helps to rid the water tank of increased dissolved solids by flushing them out the overflow during the harvest (thawing) period.

The wet suction gas leaves the freezer and passes through the suction accumulator (**), where liquid droplets are removed, allowing dry gas to enter the suction side of the compressor. The suction gas is then compressed and discharged once again, completing the cycle. As ice continues to form in the freezer tubes, the suction pressure steadily decreases, when the freeze timer (T2) times out the contact closes, initiating the thaw (harvest) cycle.

Note: Freezing time will vary, depending on make-up water temperature and thickness of ice produced. The freeze timer (T2) should be set to provide the correct time to produce ice at the required thickness under the current operating conditions.

During the harvest period, the "D" thawing gas valve (18) opens and the compressor unloads (when required), allowing the warm high pressure gas from the receiver to enter the freezer. As the tubes warm up to slightly above freezing (approximately 40 °F / 5 °C), the ice inside the tubes releases and falls down onto the rotating cutter for sizing and discharging. Harvesting requires about three minutes, but can vary depending on ice thickness, suction pressure, discharge pressure (thawing gas temperature) and distance from the receiver to the freezer.

! IMPORTANT !

It is a good idea and will be profitable for you to observe and become familiar with the proper operating characteristics of your Tube-Ice® machine. It will help you to recognize and correct minor irregularities as they occur in order to help prevent major problems.

“An ounce of prevention is worth a pound of cure.”

! IMPORTANT !

START-UP AND OPERATION

Charging From Cylinders (dedicated high side only). The machine may also be charged from refrigerant cylinders. To charge from cylinders, the compressor will have to operate to transfer the ammonia from the freezer to the receiver. Again, make sure all the necessary valves are opened for operation and the compressor crankcase heater has been energized for a minimum of four (4) hours.

Follow these instructions with caution:

1. Using a approved for ammonia charging hose, connect one end to the charging valve (30) located on the freezer.
2. Lay a full cylinder of anhydrous ammonia horizontally with the cylinder valve outlet pointing up to withdraw liquid and the bottom end raised about 2” higher than the top end.
3. Connect the other end of the charging hose to the cylinder valve. It is recommended that a gage be attached to this line to indicate cylinder pressure.
4. Close the liquid line stop valve (24) or the receiver liquid feed valve.
5. Open charging valve (30) and carefully purge air from the charging hose.
6. Open the cylinder valve slowly, checking for leaks in the line and allow the suction pressure to build up to approximately 40 psig and check again for leaks in the system.
7. Set the freeze timer (T2) to maximum setting. If the machine contains a pressure switch in place of the freeze timer, disconnect and lock out the power, open the control panel door and disconnect the freezer pressure switch, then turn the power back on.
8. Check compressor rotation by starting and stopping the compressor momentarily. Jog the compressor by using the green “Start” push button (PB2) and the red “Stop” push button (PB1) in sequence. Correct compressor rotation is indicated by an arrow on the outer rim of the oil pump assembly (opposite the shaft end of the compressor).
9. Set the “Clean/Off/Ice” Switch (SS) to the “Ice” position allowing the circulating water pump to circulate water through the freezer.
10. As the pressure continues to rise in the freezer, start the compressor and pump the ammonia into the receiver. Make sure water is circulating through the condenser and freezer tubes.
11. The machine will make ice during the process and care should be taken not to freeze the ice solid. If necessary harvest the ice and repeat the process.

If a refrigeration system is being charged from refrigerant cylinders, disconnect each cylinder when empty or when the system is fully charged. A gage should be installed in the charging line to indicate refrigerant cylinder pressure. The cylinder may be considered empty of liquid R-717 refrigerant when the gauge pressure is 25 pounds or less and there is no frost on the cylinder. Close the refrigerant charging valve and cylinder valve before disconnecting the hose from the cylinder. Loosen the union in the refrigerant charging line--carefully to avoid liquid ammonia release into the atmosphere.

! CAUTION !

Immediately close system charging valve at commencement of defrost or thawing cycle if refrigerant cylinder is connected. Never leave a refrigerant cylinder connected to system except during charging operation. Failure to observe either of these precautions can result in transferring refrigerant from the system to the refrigerant cylinder, over-filling it, and possibly causing the cylinder to rupture because of pressure from expansion of the liquid refrigerant.

! CAUTION !

STAR-UP AND OPERATION

Transferring refrigerant from a refrigeration system into a cylinder can be very dangerous and is not recommended.

As the machine is being charged, continually observe the following operating characteristics:

- a) Discharge pressure - 175 psi to 200 psi maximum
- b) Compressor oil pressure - Mycom W-Series, 18-27 psi, Vilter 450-Series, 35-50 psi.
Other models will vary (check manufacturer's specifications).
- c) Liquid level in receiver
- d) Compressor oil level

While charging the machine, the low pressure switch will stop operation of the compressor at set point pressure. The switch will automatically reset at the differential pressure at which time you can restart the machine (some low pressure switches may be manual reset). It is best to use warm water in the tank and open the tank drain valve somewhat to allow cold water to exit and warm water to enter continually. The idea is to prevent ice from freezing in the tubes as much as possible while charging. It may be necessary to initiate a short harvest cycle to dispel any ice made.

To initiate a harvest cycle, close the charging valve and push the start/manual harvest push button (PB2) while the compressor is running. This will initiate a harvest and another freeze cycle will start immediately following to continue the charging procedure. Be sure to close the cylinder shut off valve during the harvest period and open it once the machine goes back into the freeze cycle. When the liquid level in the receiver is near the pump down level and the freezer is down to 15 psi suction with little or no frost on the shell, you can stop the charging procedure and disconnect the cylinder. Make sure the charging valve is closed and the cylinder valve is closed before attempting to disconnect the cylinder. Loosen the union in the charging line gradually to relieve the ammonia pressure slowly.

When charging is complete, stop the machine, disconnect and lock-out the power. If the machine contains a pressure switch, open the control panel door and reconnect. Open liquid line stop valve (24) and/or receiver liquid feed valve and you will hear liquid refrigerant flowing through to the liquid solenoid valve (25). Turn main power disconnect to the on position and the machine is ready for start-up and ice production.

Start-up

FIGURE 5-1
Bottom Of Control Panel

Starting the machine in freeze mode:

(NOTE: machine will always start in the harvest mode when the “Clean/Off/Ice” selector switch is turned to “Ice”)

1. Make sure the crankcase oil temperature is approximately 100 °F and there is no liquid ammonia in the crankcase.
2. Set the “Clean/Off/Ice” selector switch (SS) to the “Clean” position.
3. Push the “Start” button (PB2) to start the water pump.
4. The pump can be stopped and started by “Stop” and “Start” push buttons to purge the tubing of air.
5. When there is good water flow, turn the “Clean/Off/Ice” switch to “Ice”, and the machine will then start in a harvest (thaw) period with the compressor running.
6. At the termination of the harvest (thaw) period, the machine will begin the freeze period.
7. Observe the oil pressure, the oil level, the discharge pressure and listen for any unusual sounds. The compressor should start unloaded and automatically start after several seconds of operation.
8. Set the thaw gas pressure regulator and/or the suction regulator (if used). See “Thaw Gas Regulator” and “Suction Regulator” on page 5-7 for instructions.
9. Be sure to observe a minimum of four (4) cycles of ice production to confirm the satisfactory operation of the machine.
10. Complete the remaining part of the “Warranty Registration/Start-Up Report” and return it to the TUBE ICE[®], LLC.

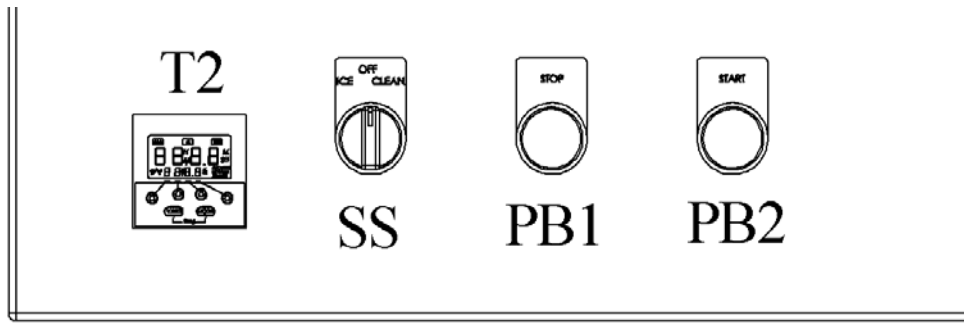
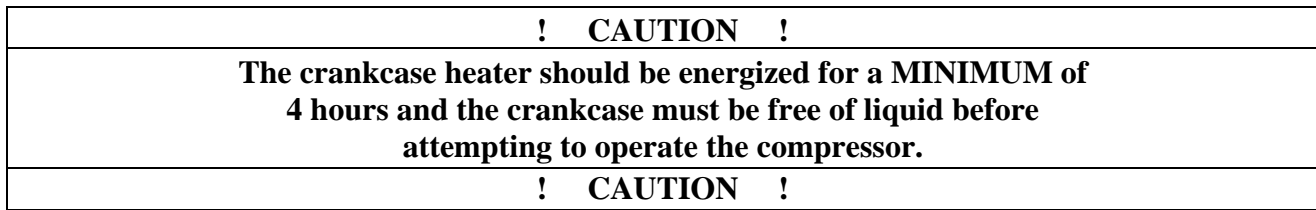
STAR-UP AND OPERATION

Thaw Gas Regulating and Suction Regulating Valve Adjustment. The following is the procedure for regulating valve adjustment. On dedicated compressor systems the suction regulating valve is not required. However the compressor must unload by 50% or greater during the harvest or a hot gas bypass must be installed.

1. Install gauge and gauge valve in gauge port of regulator.
2. Turn high pressure stem (down stream pressure) on suction regulator into the milled flats, do not turn milled flats into packing nut.
3. Start the machine and initiate a harvest.
4. Adjust thaw gas regulator to build pressure to 60 - 65 psig (1 turn is approximately 13 psig).
5. Adjust (downstream) high pressure stem on suction regulator to begin regulating at 59-64 psig. (slightly below the thaw gas regulator)
6. After the machine has completed the harvest cycle and returned to the freeze cycle, adjust the low pressure (upstream pressure) on the suction regulator to maintain the required freezer pressure. For clear ice a minimum of 20 psig freezer pressure is required.

Shut-down

! CAUTION !
The red “Stop” button should only be used for emergency shutdown. For normal shutdown use the “Clean/Off/Ice” button.
! CAUTION !

1. Set the “Clean/Off/Ice” switch to the “Off” position. Do not use the machine disconnect to stop the machine. If the disconnect is used the crankcase heater will be de-energized and liquid refrigerant will migrate to the compressor.
2. If in a freeze mode, the machine will continue to run.
3. At the completion of the freeze cycle the machine will harvest and stop. The completion of a cycle ensures that all ice is removed from the freezer to prevent refreeze when the machine is restarted.
4. If in a harvest, the machine will complete the harvest and stop.

Operating Tips

- If the operation of your machine is not controlled by a timer, bin level control or some other mechanism to automatically start and stop ice production, you should use **ONLY** the “Clean/Off/Ice” toggle switch to start and stop machine.

By turning the “Clean/Off/Ice” selector switch to “Off”, the machine will stop after the next harvest cycle.

- Do not use the “Stop” push button or the machine disconnect for normal shutdown of the machine.
- Throw the “Disconnect” only in an emergency or for safety when performing certain service or repairs to the machine. The compressor crankcase heater is de-energized when the disconnect is thrown.
- The “Start” push button can be used to initiate a harvest cycle. When it is pushed during a freeze cycle, it will immediately initiate a harvest cycle.

6. Electrical Controls

Your packaged Tube-Ice[®] machine is equipped with cutter and pump motor starters (CU and P) and a transformer (if required) for the control circuit power. The control panel and transformer are mounted on the machine front side (see Figure 1-1).

The control panel wiring schematic, FIGURE 6-3, illustrates these components as well as provisions for auxiliary equipment which may be incorporated by the customer such as:

Fused Main power disconnect
(2CR) NO Highside “On” Auxiliary Contact
(T3) Conveyor “On” Timer

When adding a high side unit or motor starters for auxiliary equipment, be sure to incorporate the overload protection as indicated between terminals #2-#12. This will assure that the machine will shutdown when any auxiliary equipment fails.

Bin Level Control. Included in the wiring schematic is provision for a bin thermostat or bin level control (BT). The NC contact of your control should be wired between terminals #11-#14 and the jumper wire removed as indicated. Installation in this manner will allow the machine to finish the harvest period before shutdown. The machine will automatically restart when the bin thermostat or bin control device is no longer in contact with the ice. To insure that the machine does not restart set the “Clean/Off/Ice” toggle switch to the “Off” position.

Safety Switches. The machine is not equipped with the following safeties and control switches, however they can be wired into the control circuit.

- Dual High/Low pressure switch (1PS) to stop the machine if the compressor suction pressure goes too low (15-20 psi) or the compressor discharge pressure goes too high (225-250 psi). Consult factory for detailed installation information.

ELECTRICAL CONTROLS

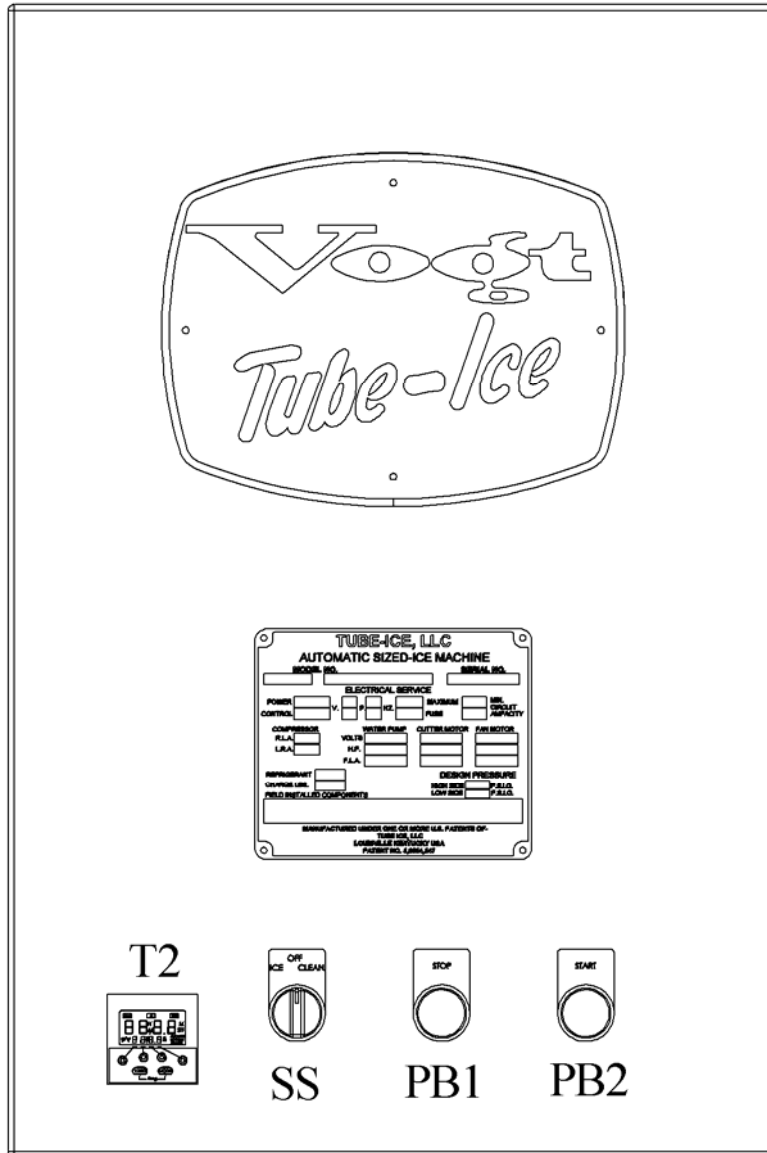

FIGURE 6-1
Control Panel (Door Closed)

Symbol	Vogt Part#	Component Description
PB1	12A7500E57	Push Button, Momentary, Red
PB2	12A7500E56	Push Button, Momentary, Green
SS	12A7500E61	Selector Switch, 3 Position
T2	12A7503E52	Timer, Digital, Multi-function, 24-240V AC

TABLE 6-1
Control Panel Components and Part Numbers (External)

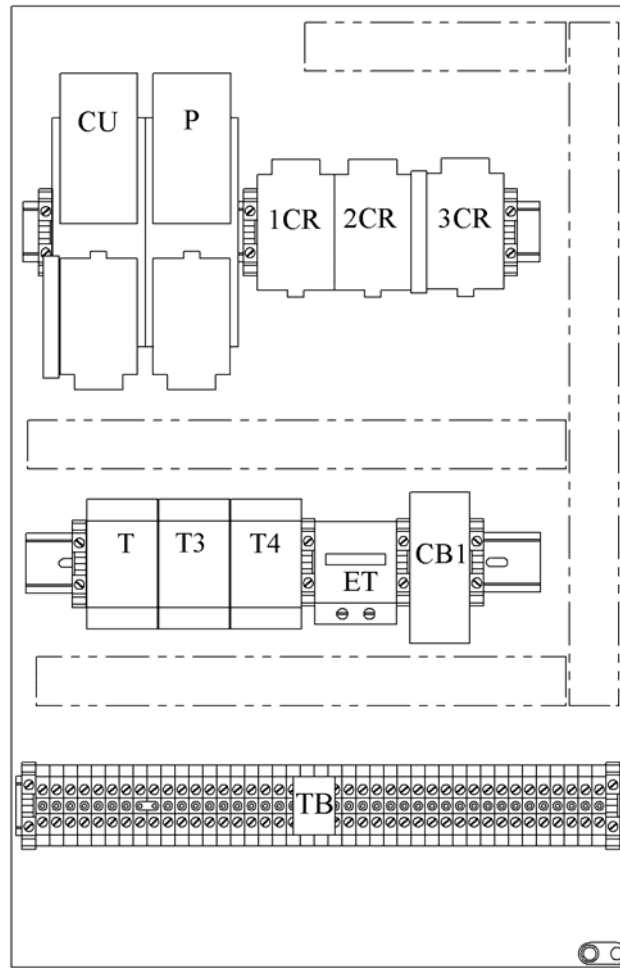

FIGURE 6-2
Control Panel (Door Opened)

Symbol	Vogt Part#	Component Description
1CR	12A7517E28	Relay, 10A, 3 NO/1NC, 208/240V Coil
2CR		
3CR		
CB1	12A7515E21	Circuit Breaker, 3A, 2 Pole
CU	12A7530E54	Cutter Manual Motor Starter, 1.6-2.5A (200/208/230V Only)
	12A7530E52	Cutter Manual Motor Starter, 0.63-1.0A (460V Only)
	12A7530E53	Cutter Manual Motor Starter, 1.0-1.6A (400V Only)
ET	12B7503E20	Timer, Elapsed, Din Rail Mount, 220V (50 Hz Only)
	12B7503E21	Timer, Elapsed, Din Rail Mount, 220V (60 Hz Only)
P	12A7530E56	Pump Manual Motor Starter, 4.0-6.3A (200/208/230V Only)
	12A7530E54	Pump Manual Motor Starter, 1.6-2.5A (460V Only)
	12A7530E55	Pump Manual Motor Starter, 2.5-4.0A (400V Only)
T	12A7503E22	Timer, Delay on make, 220V Timer Base, 8 Pin, Guarded Terminal
T3		
T4		
TB	19T7501E09	Terminal Block Assembly

TABLE 6-2
Control Panel Components and Part Numbers (Internal)

ELECTRICAL CONTROLS

Symbol	Component Description
1CR	Relay for making and breaking various circuits during freezing and thawing. Energized during the thaw period.
2CR	Relay for making and breaking various circuits during freezing and thawing. Energized during all operational modes.
3CR	Relay stops the machine when there is a power failure or interruption and must be manually re-energized by hitting the start button.
CB1	Overload and short circuit protection for the crankcase heater and the control circuit.
CU	Stops cutter motor in the event of a mechanical or electrical failure that results in excessive motor amperes.
ET	Indicates hours of machine operation. Energized when compressor is operating.
P	Stops pump motor in the event of a mechanical or electrical failure, which results in excessive motor amperes.
PB1	Used to stop machine immediately (Should be used for emergency stopping only).
PB2	Used for starting machine or manually harvesting. Will initiate a harvest cycle whenever pushed with the "Clean/Off/Ice" selector switch in the "Ice" position and machine operating in a freeze cycle.
SS	Used to select operating mode of machine. When in clean position, only the water pump will run. This allows cleaner to be circulated through the freezer without making ice. In the off position, the machine will shut down after the completion of a freeze and harvest period. In the ice position, machine will cycle on and off based on a control signal (i.e. bin thermostat or timer) or run continuously until manually stopped by setting the switch to the "Off" position.
T	Controls the duration of the thawing period.
T2	Control the duration of the freeze period.
T3	Controls the duration of conveyer operation.
T4	Controls the duration of the flush valve operation.
TB	Numbered for multiple wire connections and ease of troubleshooting.

TABLE 6-3
Description of Control Panel Component Function

ELECTRICAL CONTROLS

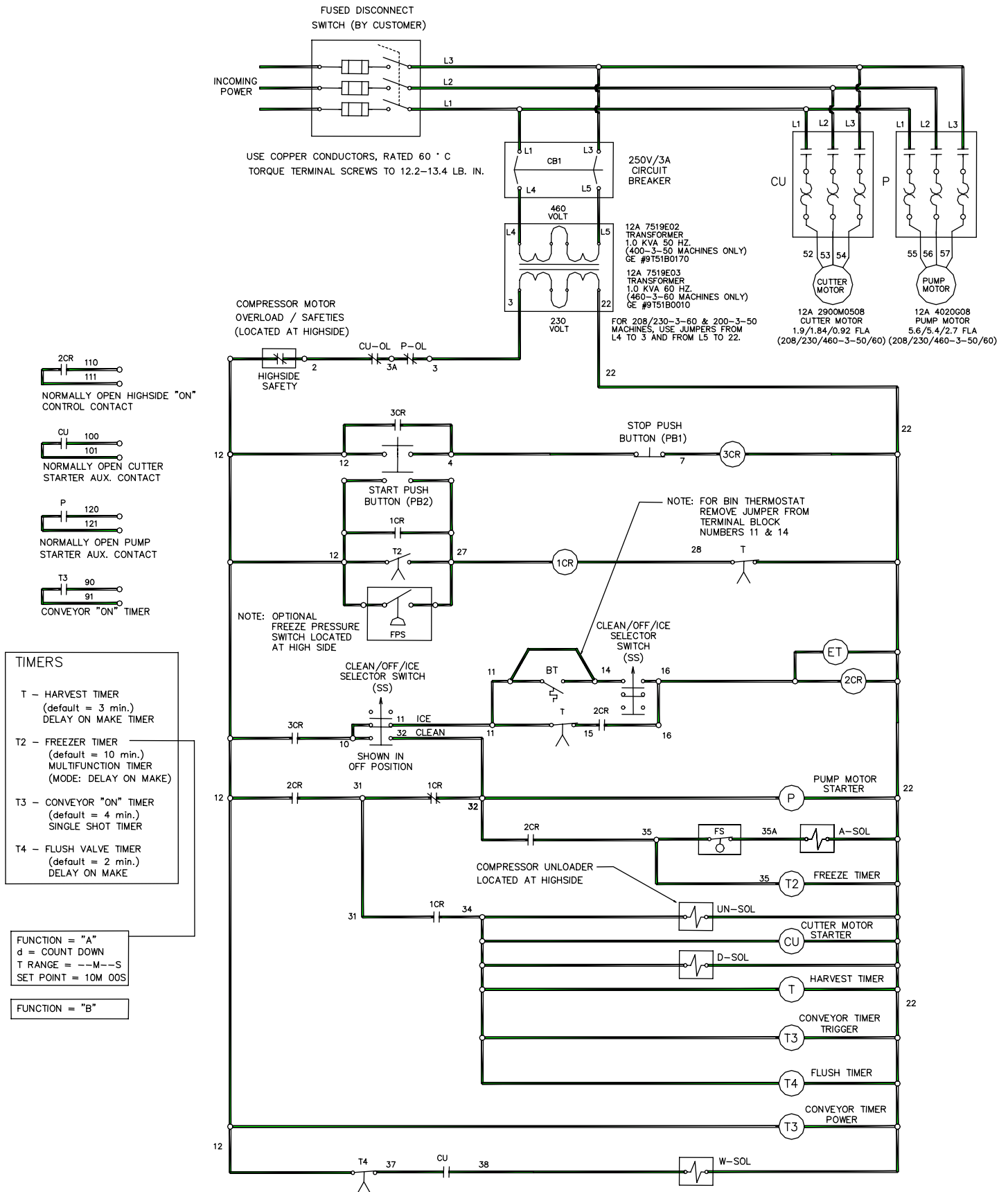

- TIMERS**
- T - HARVEST TIMER (default = 3 min.) DELAY ON MAKE TIMER
 - T2 - FREEZER TIMER (default = 10 min.) MULTIFUNCTION TIMER (MODE: DELAY ON MAKE)
 - T3 - CONVEYOR "ON" TIMER (default = 4 min.) SINGLE SHOT TIMER
 - T4 - FLUSH VALVE TIMER (default = 2 min.) DELAY ON MAKE

FUNCTION = "A"
d = COUNT DOWN
T RANGE = --M--S
SET POINT = 10M OOS

FUNCTION = "B"

FIGURE 6-3
Electrical Schematic, All Voltages, 50-60 Hz.

ELECTRICAL CONTROLS

7. Maintenance

Preventive Maintenance A careful inspection of the Tube-Ice[®] machines refrigeration system for leaks and correct operational functions at time of installation will start its long satisfactory life of service. In order to insure this degree of dependability, a systematic maintenance program is recommended. Therefore, the following schedule is suggested as a minimum.

A. Daily

- 1) Check operating pressures (suction, discharge, oil).
- 2) Check ice quality.
- 3) Check “ice out” time (maintain 30 seconds of continued harvest after last ice is out).
- 4) Check compressor oil level.
- 5) Check refrigerant operation level.
- 6) Check frost pattern on freezer shell and oil trap.
- 7) Check make-up water float valve adjustment.

B. Weekly (in addition to daily checks)

- 1) Check for leaks after 400 hours or four weeks of operation

C. Monthly (in addition to weekly checks)

- 1) Check calibration and operation of all controls (high and low pressure switches, oil pressure switch, etc.)
- 2) Check cooling tower spray nozzles and pump suction screen for scaling and algae (consult water treatment suppliers for corrective measures).
- 3) Check water distributors in freezer for scale accumulation.
- 4) Check water tank for solids to be removed.
- 5) Check all motor drive units (compressor, cutter and pump motors, cooling tower fan, and pump, etc) for abnormal noise and/or vibrations.
- 6) Check oil level in gear reducer.
- 7) Check one complete freeze/thaw cycle, record data and compare with production check of Registration/Start-up Report.

D. Yearly (in addition to weekly and monthly)

- 1) Check entire system for leaks.
- 2) Drain water from condenser and cooling tower and check condenser tubes. Check closely for damage by corrosion or scale.
- 3) Remove all rust from all equipment, clean, and paint.
- 4) Check all motors for shaft wear and end play.
- 5) Check operation and general condition of all electrical controls, relays, motor starters, and solenoid valves.
- 6) Check freezing time, ice release time, and ice out time.
- 7) Change oil in gear reducer box once a year.
- 8) Lubricate compressor motor bearings.

MAINTENANCE

PREVENTATIVE MAINTENANCE FORM

This form can be removed and duplicated for record keeping.

Date: _____ Model #: _____ Serial #: _____

The following service performed and checked:

- Hour meter reading _____ , Ambient temperature (inside) _____ °F
- Make-Up water float valve adjusted properly
- Water distributors clean and in place
- All drains freely draining
- Cleaned and flushed water tank
- Compressor oil changed
- Cleaned and inspected inside compressor crankcase
- Changed compressor oil filter
- Checked/adjusted compressor belt tension or alignment
- Lubricate compressor motor bearings
- Check/change cutter gear reducer oil
- Check/adjust cutter drive gear meshing
- Leak check entire system
- Check liquid refrigerant level in receiver
- Drained oil from oil trap
- Compressor crankcase heater working
- Compressor net oil pressure (gage reading less suction)

Motor amps: Compressor _____ Cutter _____ Pump _____

Suction psig (end of freeze) _____ Discharge psig (end of freeze) _____
 Suction psig (end of thaw) _____ Discharge psig (end of thaw) _____

Compressor water out ____ °F Tower fan cycles ___ On ___ Off

Ice Production Check

Test Cycle	Make-up Water Temp	Freezing Time Min/Sec	Harvest Time Min/Sec	First Ice Out Min/Sec	All Ice Out Min/Sec	Avg. Hole Size	Ice lb. Per Harvest (estimated)	Ice lb. Per Day (estimated)
#1								
#2								
#3								
#4								

Comments: _____

Name: _____

Ice Making Section The ice-making section of the Tube-Ice[®] machine should be cleaned at least twice a year (more often if water conditions cause mineral build-up). Use an approved food-

grade ice machine cleaner. The water pump is used to circulate the cleaner through the system by setting the “Clean/Off/Ice” selector switch to “Clean” to start the water pump and to “Off” to stop the water pump. For complete instructions, refer to the “Cleaning Procedure” attached to the equipment and duplicated here.

Cleaning Procedure

1. Before cleaning any Tube-Ice machine make sure the crankcase heater is working properly. When the crankcase heater is not working there is a possibility for refrigerant evaporated by warm circulating water to migrate to the compressor during the cleaning operation.
2. Set ‘Clean/Off/Ice’ selector switch (SS) to “Off” position. If the machine is running, it will shut down on completion of the next ice harvest period.
3. Remove ice from storage area or cover ice discharge opening to prevent water from splashing out and contaminating stored ice.
4. Shut off water supply and drain water tank (13) by opening drain valve (28). Remove any loose sediment from tank.
5. Close drain valve (28) and fill water tank (approximately 27 gallons) with warm water.
6. Add 72 ounces (8 ounces per 3 gallons) of Calgon[®] ice machine cleaner (a food grade liquid phosphoric acid) to water tank during the refill period.
7. Inspect the water distributors by looking through clean freeze cover. If required, remove the cover. Clean and remove any solid particles from the distributor orifices (two orifices in each distributor). Clean the rubber cover gasket and reinstall the cover.
8. To run the pump only, set the “Clean/Off/Ice” selector switch (SS) to the “Clean” position and press “Start”.
9. Circulate cleaning solution until deposits are dissolved or solution is neutralized. Repeat cleaning if necessary.
10. Press “Stop” button to stop pump, then drain and flush water tank with fresh water. Open water supply to machine.
11. Drain and flush tank and then refill with fresh water.
12. Clean inside of ice storage area and remove any solution that entered during the cleaning process. Remove cover if one was installed over opening into storage area.
13. Start ice making cycle by setting the “Clean/Off/Ice” (SS) switch to “On”. Check for water leaks around the freezer cover and tighten nuts if needed.

MAINTENANCE

Water Distribution System

Water Distributors. The water distributors are located under the freezer cover at the top of the freezer. These distributors may require occasional or periodic cleaning to remove solids and foreign particles accumulated from the make-up water. The frequency of this cleaning operation will depend on the characteristics of the water supply. The cleaning operation is needed when the inside diameter of a large proportion of the ice becomes irregular (due to channeling of water), or if some of the ice is opaque, or if there is a noticeable decrease in ice capacity.

Tube Size	1"	1 1/4"	1 1/2"
Number of Water Distributors	156	102	72

TABLE 7-1
Number of Water Distributors Per Tube Size

To clean distributors, stop the unit and remove the freezer cover on top of the freezer. The water distributors (one in each tube) may then be removed with pliers for cleaning. Use pliers on the distributor's top part with a twisting upward motion. Use care when removing distributors to avoid distorting orifice holes or the body of the distributor. The distributors can be soaked in ice machine cleaner to remove mineral buildup. Rinse distributors thoroughly before reinstalling and tap lightly with a rubber mallet to seat them in the freezer tubes.

Tube Size	1"	1 1/4"	1 1/2"
Hole Size	1/16"-1/8"	1/8"-3/16"	1/4"-3/8"
	Avg.	Avg.	Avg.

TABLE 7-2
Average Hole Size In Tube-Ice®

Water Tank. The production of opaque ice can indicate that the water in the water tank contains a concentrated amount of solids or salts. Remove cover plate. Open drain valve (28). Clean tank thoroughly by flushing out with a hose and scrubbing with a stiff brush. It may be necessary to completely remove the water tank in order clean all surfaces. The tank has casters to simplify removal. After cleaning, close drain (reinstall tank if necessary) and fill the water tank with fresh water. When restarting the machine, be sure that the water pump is circulating water. It is possible that air may have collected in the pump impeller housing and the pump may have to be stopped and started several times to expel the air.

Freezer Cover. A clear polycarbonate freezer cover is provided for visual inspection of the water box and water distributors located at the top of the freezer. The cover should be removed and cleaned if it becomes coated with deposits. Generally, if the freezer cover is coated with solids this is a prime indicator that the other areas (i.e. water tank and distributors) also require cleaning.

! CAUTION !
The water distribution system is critical to proper machine operation. Failure to maintain and clean water distribution components can result in improper machine operation and compressor failure.
! CAUTION !

Other Maintenance Operations

Cutter Gear Reducer. The oil level of the gear reducer should be checked monthly or when there is any evidence of leakage. The correct level is indicated by the pipe plug in the side of the gear housing. The oil should run out of the hole when the plug is taken out. If low, add oil through one of the top plugged holes. A high grade lubricant such as Mobil 600W or SAE 140 gear oil should be used. The oil should be changed annually. Drain the oil and flush the gear case with mineral spirits. Drain the mineral spirits completely and refill with the proper oil.

Note: If a USDA high food grade lubricant is desired, use Chevron FM Lubricating Oil 460X.

! CAUTION !
Follow all lock-out and tag-out procedures before servicing any electrical equipment.
! CAUTION !

Oil Trap. Although the compressor is equipped with an oil separator, which has an automatic return, some oil will pass through the separator and eventually settle in the oil trap (22), which is offset from the base of the freezer. This oil trap will have evidence of frost on its surface during the freeze cycle and may be more pronounced at the end of a normal freeze cycle just before the harvest. Where there is oil in the trap, there will not be frost. Where there is frost, there will not be oil. When the trap is 1/2 to 3/4 full of oil, it should be drained.

The machine should be shutdown for at least 12 hours before attempting to drain oil from the trap. Follow the procedure outlined in the service section, "Draining Oil Trap".

! CAUTION !
Only qualified refrigeration service personnel familiar and experienced in the handling and use of anhydrous ammonia (R717) should be authorized to perform the "Draining Oil Trap" procedure.
! CAUTION !

Optional Maintenance Operations

The following sections outline some general guidelines for service of auxiliary equipment. Always follow the instructions provided by equipment manufacturers when performing service operations or scheduled maintenance.

Water Cooled Condenser Cleaning (optional). As water evaporates from a cooling tower, the solid impurities remain and must be flushed from the system to prevent a scale build-up in the condenser and cooling tower. This can be accomplished by a continuous bleed off valve located in the pump discharge line. The valve should be adjusted to bleed off an equal amount of water that is evaporated. If water hardness is very high, a higher bleed off rate or chemical treatment may be required. Consult you local water treatment company for recommendations.

If after a period of time, scale has formed inside the tubes, mechanical cleaning may be necessary. See "Servicing Section--Condenser".

Cooling Tower/Evaporative Condenser (optional).

MAINTENANCE

1. Bleed off valve. The bleed off valve should be checked monthly to assure that is not blocked and that water is flowing as required. If the unit is controlled by a water treatment system, the bleed off valve may not be required.
2. Strainer. The pan or sump strainer is located in the bottom of the sump at the suction connection to the pump. The strainer should be inspected monthly and kept clean. Do not operate the unit without the strainer in place.
3. Make-up water float valve. This valve should be checked monthly for proper operation and adjustment. It should be adjusted to maintain a water level below the overflow and high enough to prevent the pump from cavitating when the system is in operation.
4. Spray nozzles. The spray nozzles should be checked monthly to make sure none are restricted and the spray pattern is complete and even.
5. Pump motor and fan motor. The motors should be checked and/or lubricated every six months according to the motor manufacturer's recommendations.
6. Fan bearings. The fan bearings should be lubricated every six months. Make sure the proper grade of grease is used (normally conforms to NLCI-Grade 2) and it is best to use a hand grease gun.
7. Fan belts. The fan belt tension should be checked weekly for the first two weeks of operation, then monthly during continuous use.

The best tension for a V-belt is the lowest tension at which the belt will not slip under its full load. Never use dressing on V-belts. Keep belts and grooves clean and free of oil, grease, and foreign material. Clean with non-flammable, non-toxic degreasing agent or commercial detergent and water.

! CAUTION !
Follow all lock-out and tag-out procedures before servicing any electrical equipment.
! CAUTION !

Maintenance Operation	Start-Up	Monthly	Six Months	Shutdown
Clean debris from unit	X	X		X
Clean strainer and flush sump	X	X		X
Check fan and pump rotation	X			
Clean spray nozzles	X	X		
Check belt tension	X	X		
Check for noise/vibration	X	X		
Check/adjust make-up water valve	X	X		
Check/adjust bleed rate	X	X		
Check/lubricate fan bearings	X		X	
Lubricate motor base adj. Screw	X		X	X
Drain sump and piping				X

TABLE 7-3
Cooling Tower Maintenance Schedule

Compressor (optional). This section is only a guide; consult the compressor manual for manufacturers recommended maintenance.

In starting and charging the unit, the oil sight glass should be continually checked to make sure an adequate oil level is maintained. The oil level should be 1/4-3/4 of the sight glass. If the oil level drops below 1/4 of the glass, add refrigeration oil as per the compressor manufacturer recommendations. Never allow the oil level to be out of sight, above or below the sight glass when the compressor is operating.

! CAUTION !
The crankcase heater should be energized for a minimum of four hours and the oil temperature should be 100°-110°F before attempting to start the compressor.
! CAUTION !

During operation, the specified net oil pressure should be maintained for proper lubrication and operation of the cylinder unloader mechanism.

Mycom N&W Series net oil pressure: 17-28 psig
 Vilter 450 Series net oil pressure: 35-50 psig

Note: Net oil pressure is calculated by subtracting the compressor suction pressure from the oil pressure gage reading while the compressor is running.

Example: Oil pressure gage reading: 65 psig
 Suction pressure gage reading: 40 psig
 Net Oil Pressure: 25 psig

The compressor oil should be changed at close intervals during initial break-in operation and up to the first 1000 hours (see Table 7-4 below).

Note: It is the owner’s responsibility to make sure normal maintenance is initiated to insure that the compressor is not subjected to premature wear or failure due to neglect or lack of sufficient maintenance and care.

Maintenance Operation	Frequency				
	1st	2nd	3rd	4th	Thereafter
Change oil	200 hr.	500 hr.	1500 hr.	4000 hr.	Every 4000 hrs.
Clean suction strainer cloth	200 hr.	500 hr.	Remove if clogging is minimal		

**TABLE 7-4
Compressor Maintenance**

The above maintenance is only a guide. The compressor should be inspected anytime there is unusual noise, damage is suspected or the oil becomes discolored. The oil should be changed any time the compressor is opened. For specific recommendations and instructions, refer to the particular compressor manufacturer’s manual.

MAINTENANCE

8.Troubleshooting

Note: Your machine's electrical system has several built-in safety and overload protection features to stop operation when a single component fails or there is a problem from an outside source such a power supply. Make sure all auxiliary equipment is connected to incorporate safety and overload circuits and protect all related equipment.

When the machine stops, it must be manually restarted by pushing the green "Start" button. The machine will restart in a harvest to clear any ice from the freezer before beginning another cycle.

Always check the machine operation thoroughly after remedying the problem. Be sure to correct the source or cause of the problem to prevent the problem from occurring again.

<u>Symptom</u>	<u>Page</u>
Machine stopped	8-2
Freeze-up due to extended freeze period	8-3
Freeze-up due to ice failing to discharge	8-3
Low ice capacity	8-4
Poor ice quality	8-5
High discharge pressure	8-5
Low discharge pressure	8-5
High suction pressure	8-6
Compressor running unloaded during freeze	8-6
Compressor oil pressure low	8-6
Compressor loosing oil excessively	8-6
Machine short cycles	8-7
High compressor discharge temperature	8-7
Suction line frosting to compressor	8-7

Contact your distributor first for technical service assistance about operation problems not covered in this manual.

Also feel free to contact the factory for additional service (502) 635-3000.

TROUBLESHOOTING

Symptom: Machine Stopped

Possible Cause	Possible Remedy
Power failure or interruption	Check fused disconnect or circuit breaker supplying power to the machine. If power has been off, make sure the crankcase heater is energized and there is no liquid refrigerant in the compressor crankcase prior to restarting the compressor. If ice is in the freezer, initiate a manual harvest.
Circuit breaker (CB4) for control circuit tripped	Check compressor crankcase heater, coils of relays, contactors, starters, solenoid valves, and thawing timer for a ground. Repair or replace any defective part and reset circuit breaker. Make sure there is no liquid refrigerant in the compressor crankcase prior to restarting the machine.
Compressor motor starter overload tripped	Check for a loose connection on all motor starter and motor terminals that could cause excessive amp draw. Reset overload and restart the machine, check amperage, power supply, and head pressure. (Check delay timer in part wind starts only).
Water pump, cutter motor, conveyor motor, overload tripped	Check for loose connection on all terminals that could cause excessive amp draw. Reset the overload and manually run that particular motor to check actual voltage and amperage against motor rating.
Freezer water pump motor overload (P) tripped	Check for loose terminal connections and/or blown fuse, reset the overload and restart by pushing the start push button (PB2). Machine will start in a harvest. Check voltage and amperage against motor rating during freeze. Confirm proper rotation.
Cutter motor overload (CU) tripped	Check for loose terminal connections and/or blown fuse. Clear all ice that may have jammed cutter. Reset the overload and restart by pushing the start push button (PB2). Machine will start in a harvest. Check voltage and amps against motor rating. If tripping repeats but ice is not jammed, check the gear reducer for resistance, cutter bearings for wear, drive gear and ring gear for proper engagement, and reducer motor for defect or single phasing.
Bin level control (optional) open	Adjust or replace control as required. If bin level control is not used, make sure jumper wire from #11 to #14 is installed at the terminal block.
High/Low pressure safety switch tripped (optional)	<p>If the machine stops by low pressure cutout, the switch will reset automatically when the pressure rises to the "cut-in" setting. Check thaw gas valve (18) to make sure it opens during harvest time. Check Liquid feed valve (25) to make sure it is feeding during a freeze.</p> <p>If the machine stops by high pressure cutout, the switch will have to be manually reset after the pressure drops below the "cut-in" setting. Check the head pressure during the next freeze cycle.</p>
Low oil pressure tripped (OPS) located on compressor	<p>Manually reset the switch after the switch heater cools. Check the crankcase oil level (1/4-3/4 full). Add oil if below 1/4 glass before attempting to restart the machine.</p> <p>Restart the machine and check net oil pressure (net oil pressure = oil pump line pressure minus crankcase suction pressure).</p> <p>Net oil pressure range: Mycom= 17-28 psig Vilter= 35-50 psig</p>
Defective control panel component such as 1PB, SS, 1CR, T	See FIGURE 6-3, Wiring Schematic, and check for open circuit. Refer to FIGURES 6-1 and 6-2, Control Panel to identify parts. Check for loose wires. Replace defective part, restart machine, check power supply, and current draw.
Fused disconnect for pump or cutter motor blown.	Check for loose connection on all terminals, replace fuse and check amp draw against fuse rating. Check voltage and current unbalance, Section 3. Replace fuse if blown.

Symptom: Freeze-up due to extended freeze period

Possible Cause	Possible Remedy
Freeze timer (T2) set to long	Adjust timer or replace if defective. See FIGURE 9-2.
Freezer pressure switch (FPS) set too low or defective (optional)	Adjust switch or replace if defective.
Water tank drain valve, make-up water float valve or flushing valve stuck or opened	Close, repair, or replace valve as needed. The float valve should be adjusted low enough that water should not run out the tank overflow during the freeze cycle.
Thaw gas solenoid valve (18) leaking through during freeze	Check the manual opening stem to make sure it is in the automatic position (stem screwed in). Check for leakage by sound, temperature difference and frost during the freeze cycle. Leakage should stop by closing the hand stop valve downstream of thaw gas valve. Isolate and repair or replace the valve as needed.
Compressor running unloaded	If the compressor is running unloaded, the motor amp draw will only be 60%-70% of the normal amp draw of a loaded compressor. Refer to the compressor manual for normal oil pressure needed to load the compressor cylinders and any further procedures to check the mechanical function of the unloader mechanism.

Symptom: Freeze-up due to ice failing to discharge

Possible Cause	Possible Remedy
Freeze timer (T2) set to long	Adjust timer or replace if defective. See FIGURE 9-2.
Extended freeze period (if freezer pressure switch is used)	Check freezer pressure switch adjustment. See FIGURE 9-1 for adjustment and TABLE 7-2 for average hole size. Make sure all water distributors are in place (one in each tube).
Thaw time too short (T)	Adjust thaw timer (T) to allow all ice to clear the cutter and ice discharge opening with at least 30 seconds to spare. Replace defective timer. See pressure regulating valve adjustment.
Thaw pressure to low	The thaw gas regulator should be adjusted to increase the pressure in the freezer to 60-65 psi during a harvest. Isolate and repair or replace the valve as needed.
Insufficient heat for thawing due to low condensing pressure	The head pressure should be maintained from 175-190 psi (maximum 200) usually by a water regulating valve or fan cycling switch. Check to make sure these controls are working properly. Cold prevailing wind can also be a factor.
Insufficient heat due to non-condensables (usually air) in the system	If non-condensables are present with the refrigerant, the saturated temperature will not relate to the pressure reading at the receiver and the refrigerant will be cooler, although pressure will be high. Air can be purged from the system by following the procedure in the Section 9, "Purging Non-Condensables".
Insufficient heat due to low refrigerant charge	The refrigerant level in the receiver should be near the operating mark at the end of a freezing cycle to provide enough volume of warm gas for harvesting. DO NOT OVERFILL RECEIVER. See Table 3-2
Cutter or cutter disc does not turn	Check cutter gear reducer and drive gear for proper operation and alignment. Check for broken gear teeth or sheared shaft key. Replace defective parts.
Compressor not running unloaded during thaw cycle. (for dedicated high side only)	Check compressor motor Amp draw. During the thaw cycle, the compressor motor Amp draw should be 60 - 70% of normal amp draw during the freeze cycle. Check compressor unloader solenoid coil to make sure it is energized and the valve is opening during the thaw cycle.

TROUBLESHOOTING

Symptom: Low ice capacity.

Suspicion of low ice capacity should be confirmed by accurate calculations of actual ice product. Significant losses can occur due to melting and off fall through augers and other ice handling equipment.

1. Time the total cycle (freeze time + thaw time).
2. Catch all the ice at the ice discharge opening of the machine for that cycle.
3. Weight the total amount of ice caught.

Lbs. ice per cycle

Cycle time minutes X 1440 = _____ lbs. production per 24 hours (Note: divide seconds by 60 to get decimal equivalent)

More than one cycle should be caught and weighed to get an accurate average.

Possible Cause	Possible Remedy
Inadequate water for ice making	Water pressure of 30 psig minimum is required to assure proper water supply. Check water pressure. Check for a restriction in the incoming line or at the make-up water float valve.
Water distributors may be stopped up	Check distributors and clean orifices as needed.
Freeze timer, Freezer pressure switch or thaw timer out of adjustment	Check hole size in Tube-Ice (See TABLE 7-2). Crushed ice should be 3/16"-1/4" thick. Check and adjust thawing time. Thawing should be 30 seconds longer than it takes for all the ice to clear the freezer.
Excessive ice chips in the water tank, causing short cycling	Check incoming water temperature (45°F minimum). Check flushing valve to make sure ice chips are being melted and flowing out the tank overflow during the harvest cycle.
Compressor running unloaded or not pumping full volume	Check compressor motor amp draw. Check for belt slippage and tighten as needed. Check for leaking compressor suction or discharge valves. Refer to your compressor manual. See other related symptoms.
Restriction in the refrigerant liquid line or float switch not operating properly	Check for a partially closed valve or an obstruction at the strainer, solenoid valve, or hand expansion valve. The liquid line will normally have frost on the downstream side of a restriction, especially as the suction pressure decreases.
Low refrigerant charge, causing re-freeze	Check the receiver gage glass mark for the proper level. Check for and repair leaks. Add refrigerant.
Warm make-up water for ice making	Capacity of the machine is proportional to ice making water temperature. Warmer water will reduce the ice making capacity. Refer to Section 11, Capacity Table. Check float adjustment and water tank drain valve.
Excessively high head pressure	Check cooling tower or evaporative condenser to make sure sufficient water is provided for cooling and the equipment is operational to cool the water. Also see "Symptom High Head Pressure".
Suction regulator out of adjustment or defective (optional)	Check the freezer pressure and compare to the main suction pressure. The suction regulator should regulate the freezer pressure and create a 2 psi pressure drop across the valve. Adjust pressure regulator. Repair or replace defective valve.
Thawing gas solenoid valve (18) leaking through during freeze cycle	Check the manual opening stem to make sure it is in the automatic position (stem screwed in). Check for leak by sound, temperature difference and frost during a freeze cycle. Close the stop valve (90) to confirm suspicion of leakage. Repair or replace the valve.

Symptom: Poor ice quality

Possible Cause	Possible Remedy
Excessive concentration of solids in the water tank usually indicated by a build-up of mineral deposit on the sides and bottom of the tank and opaque ice production. Also, water distributors restricted.	Perform a cleaning procedure as well as removing the freezer cover and cleaning the water distributors. Make sure the flushing valve (27) is functioning and the tank overflow piping is not restricted.
Insufficient water supply indicated by a low level in the tank	Check water pressure, 30 psig is recommended minimum. Check for a water line restriction, partially closed valve, or defective make-up water float valve. Make sure the water tank drain is closed.
Water pump rotation wrong direction	Check rotation in relation with arrow on pump housing and reverse two wires at the motor if necessary.
Low refrigerant charge, causing an ice out problem and re-freeze	Check refrigerant level mark on the receiver and on the painted portion of the gage glass guard. Be sure to keep the gage glass cocks closed when finished checking the level.
Suction Pressure to low	Adjust suction regulator valve
Restriction in liquid line, causing short freeze cycle	Check for closed valve, defective solenoid valve (25), float switch defective or strainer restricted. The liquid line will normally have frost on the down-stream side of a restriction, especially as the suction pressure decreases.

Symptom: High discharge pressure (check gage accuracy)

Possible Cause	Possible Remedy
Insufficient water flow through the cooling tower or condenser	Check the condenser water pump to make sure it is pumping enough water. Check sump strainer screen and clean. Check condenser pump direction of rotation.
Fan control out of adjustment	Check adjustment. Replace if defective.
Non-condensable in system.	If non-condensables are present with the refrigerant, the saturated temperature will not relate to the pressure reading at the receiver. The refrigerant will be cooler, although the pressure will be high. Air can be purged from the system by following instructions in Section 9, "Purging Non-Condensables".
Cooling tower or evaporative condenser requires maintenance	Check fan motor and fan belts for proper operation and tension. Check spray nozzles, tubes, sump, and sump screen, for accumulation of mineral deposit and clean as required. Check tower blowdown and chemical treatment if applicable.
Dirty condenser tubes	Visually inspect the condenser tubes to see if there is any build-up of mineral deposits which would reduce the cooling effect of the tubes and water. Clean chemically or mechanically as applicable.

Symptom: Low discharge pressure (check gage accuracy)

Possible Cause	Possible Remedy
Fan cycling switch out of adjustment or defective	Check adjustment. Replace if defective.
Compressor running unloaded or not pumping efficiently	Check compressor motor amp. If the compressor is running unloaded, the amperage will only be approximately 60% of normal amp draw (FLA). Refer to the compressor manual.
Ambient temperature low and prevailing winds blowing through tower	Shield tower from prevailing winds to prevent excessive cooling. Install an indoor sump.
Too much cold water circulating through condenser	Install a water regulating valve in the water line form the condenser and control flow by receiver pressure.
Thaw gas valve (18) leaking through	Make sure manual opening stem is in the automatic (screwed in) position. Repair or replace defective parts.

TROUBLESHOOTING

Symptom: High suction pressure (check gage accuracy)

Possible Cause	Possible Remedy
Compressor running unloaded or not pumping efficiently	Check compressor motor amp. If the compressor is running unloaded, the amperage will only be approximately 60% of normal amp draw. Refer to the compressor manual.
Thaw gas valve (18) leaking through	Make sure manual opening stem is in the automatic (screwed in) position. Repair or replace defective parts.
Suction Pressure to low	Adjust suction regulator valve
Defective gage	Check pressure with accurate gage and replace as necessary.

Symptom: Compressor running unloaded during freeze (dedicated compressor only)

Possible Cause	Possible Remedy
Low oil pressure	Check compressor net oil pressure. Net oil pressure = oil pressure gage reading less suction pressure. Mycom = 17-28 psig Vilter = 35-50 psig. Refer to the compressor manual for "Oil Pressure Adjustment".
Unloader solenoid valve open	Check solenoid coil to make sure it is not energized. If valve is stuck open, replace valve.
Unloader mechanism not working properly	Refer to compressor manual. Mycom compressor can be loaded manually.

Symptom: Compressor oil pressure low (check gages)

See Section 7, for compressor oil pressure requirements.

Possible Cause	Possible Remedy
Oil diluted with refrigerant	Oil will be very foamy. Check liquid feed control for overfeed problem.
Oil pressure regulating valve out of adjustment	Adjust valve to increase oil pressure. Turn stem in to increase, out to decrease.
Compressor rotation incorrect	Check rotation direction by arrow indication. Reverse rotation, if necessary.
Restriction strainer, oil filter, pick-up tube or oil passage	Clean strainer or restriction in passage or replace filter.
Compressor thrust bearing installed upside down	The Mycom compressor thrust bearing on the shaft seal end has an oil passage hole that has to be in the proper position when installing the thrust bearing. Hole up for "WA" and "WB" series Mycom compressor. Refer to your compressor manual.

Symptom: Compressor losing oil excessively

Possible Cause	Possible Remedy
Non-effective oil separator or float	The oil separator will normally return a good portion of oil leaving the compressor, if it is working properly. Check the oil float and return line to see it is not restricted.
Liquid refrigerant in crankcase	Check liquid feed to make sure it is not overfeeding and that the solenoid valve (25) is not leaking through when the machine is stopped.
Compressor piston rings seized or broken	Check compressor efficiency. If rings are seized or broken, replace defective parts.
Leaking shaft seal	A few drops per minute is okay. If ammonia is leaking, replace the seal.

Symptom: Machine short cycles (using freeze pressure switch (FPS) only)

Possible Cause	Possible Remedy
Freezer pressure switch (FPS) set too low or defective	Adjust switch or replace if defective.
Freeze-up	See "Freeze-up due to extended freezer period" and "Freeze-up due to ice failing to discharge".
Clogged water distributors	Clean water distributors.
Lack of water for making ice	Check water tank for sufficient water level. Check for restriction in water line, defective float valve, open drain valve, excessive ice chips or low water pressure and correct.
Lack of sufficient liquid refrigerant feed	Check float and float switch, solenoid valve and coil in liquid line, strainer, and refrigerant level in receiver.
Water pump rotation incorrect or pump defective	Check pump motor rotation. Check for leaking pump seal or defective motor and repair or replace as needed.

Symptom: High compressor discharge temperature

Possible Cause	Possible Remedy
High head pressure	Check gage accuracy and "High discharge pressure".
Defective suction or discharge valves	Feel the compressor heads for hot spots or one head running hot. Replace worn or leaking valves.
Restriction in the discharge gas line	Check all hand and check valves to make sure they are fully opened and not stuck. Repair or replace as needed.
Internal relief valve leaking	Check the compressor manual to see if your compressor is so equipped. Replace accordingly.

Symptom: Suction line frosting to compressor

Possible Cause	Possible Remedy
Liquid refrigerant overfeed	Check float switch to make sure it is functioning properly. Replace if defective. Check solenoid valve (25) to make sure it is not leaking through. Repair or replace if defective.
Refrigerant contaminated with water	Test refrigerant or oil for water contamination. Completely pump the freezer out (pumpdown) and blow excess water out through the oil trap drain valve. Refer to Service, Section 9 "Removing Excess Water".

TROUBLESHOOTING

9. Service Operations

Thawing Timer (T). The thawing timer governs the ice thawing period. It is located inside the control panel (FIGURE 6-1). It is started by action of the freeze timer (T2), which energizes the “1CR” relay. This timer is set prior to shipment for approximately a two-minute period.

Set the thawing period for at least 30 seconds longer than the time required to harvest the entire discharge of ice. If it should be necessary to change the setting of the timer, turn the adjustment screw clockwise to increase the time or counter-clockwise to decrease the time. Check thaw time after each adjustment.

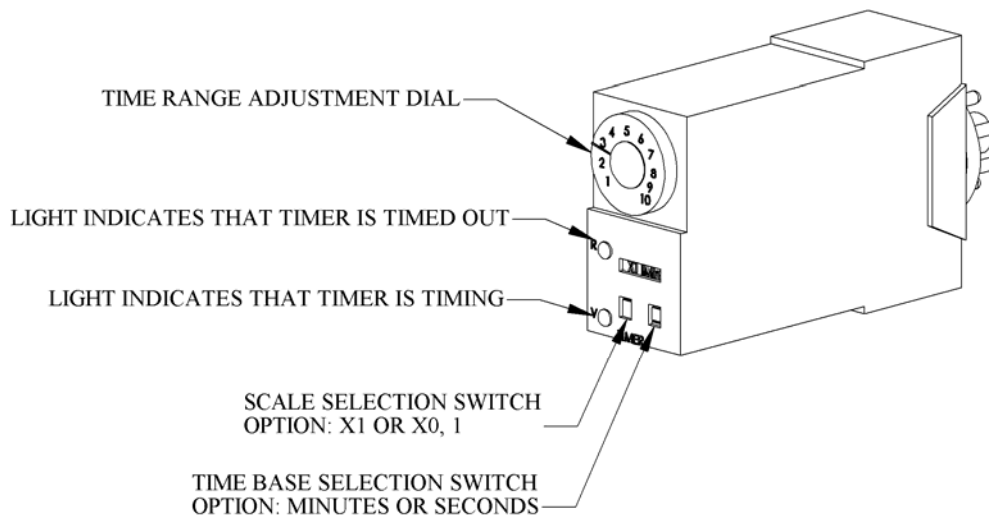

FIGURE 9-1
Timer Settings

Freeze Timer (T2). The freezing time period for the production of cylinder or crushed ice is controlled by the freeze timer mounted on the control panel door.

The timer was set at the factory to a default of 10 minutes. The freeze time can be adjusted to compensate for water temperature and refrigeration system conditions. Do not make adjustments until several ice-discharging cycles have been made.

Digital Timer Setting Procedure (initial) The following procedure is recommended for initially setting a Syrelec timer which has **not** been previously adjusted:

1. Press the valid and mode key simultaneously to set the time range. Set at __ M __ S (Minutes and Seconds).
2. Press the mode key only to move to the count mode. Set at d (down count)
3. Press the mode key again to move to out mode setting. Set at A for delay on break.
4. Press valid to exit mode setup. Set freeze time to 10 minutes by using the four round buttons.

SERVICE OPERATIONS

The freezing time can be such that a small percentage of the ice is frozen solid. If so, some ice from the top and bottom of the freezer should have a small hole in the center to insure that the freezing time has not been extended to where a loss in capacity would result. It is preferable that the freezing cycle be such that a small diameter hole remains in the center of the ice cylinder. (1/16" diameter for 7/8" diameter ice, 1/8" diameter for 1 1/8" diameter ice. 1/4" diameter for 1 3/8" diameter ice) This insures that the freezing cycle is not extended unnecessarily and eliminates a possible opaque core in the center of the ice.

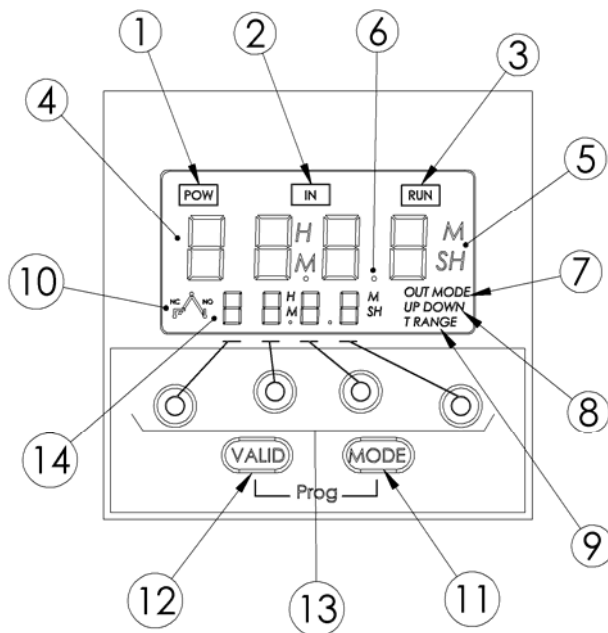

Digital Timer Readout Legend	
1.	Power supply symbol
2.	Closed control contact symbol
3.	Flashing symbol during time delay
4.	Current value readout (4 digits)
5.	Unit of time
6.	Separation of units of time
7.	Operating Modes
8.	Increasing (Up) or Decreasing (Down)
9.	Time range
10.	Changeover relay status symbol (NC = Normally Closed, NO = Normally Open)
11.	Next stage
12.	Configuration Validation
13.	Incrementation of T
14.	Display of time pre-selection T (4 digits)

FIGURE 9-2
Multi-function Digital Freeze Timer

Conveyor Timer (T3). An added feature of your machine is a conveyor timer. This timer can be used to control the duration of operation of a conveyor or screw.

Flush Valve Timer (T4). A feature of this machine is the automatic blowdown, which is provided to eliminate or reduce the necessity for frequent flushing or cleaning of the water tank. The primary purpose of the automatic blowdown is to remove accumulated salts and/or solids from the water tank that accumulate during the freezing cycle. This flushing action each cycle greatly reduces the total dissolved solids in the tank and results in clear ice production.

At the beginning of a harvest cycle a solenoid operated valve is actuated which allows water to flow into the tank during the harvest cycle. The valve is actuated by a timer that allows for adjustment of the amount of water discharged during the harvest period (see figure 9-1 for settings). The machine should be started and run initially with a 30 second blowdown period and gradually increased until clear ice is produced.

Make-up Water Float Valve (37A). The make-up float valve maintains the proper level in the water tank for ice making. The valve should be set to maintain a water level in the water tank during the freezing period so that there will be a quantity of blowdown only during the thaw mode. The water level during the freeze mode should always be below the overflow piping to prevent excessive waste of cold water, resulting in loss of ice capacity.

If it should become necessary to clean the float valve, close the stop valve in the make-up water line to the machine and remove the float valve. After the valve has been cleaned and reinstalled, check to ascertain if the proper water level is being maintained. After the machine is stopped and the water in the tank seeks its normal level, there should be no water flow through the float valve or overflow.

It is advisable to install a large area strainer in the water supply line to protect the float valve from dirt or solids in the water that would necessitate frequent cleaning. A strainer of 40-mesh screen is usually satisfactory.

Refrigerant Float Switch (23). The float switch is installed on a header assembly that is attached to the freezer shell. Valves are provided for isolation of the float switch assembly if replacement or servicing is necessary. The float switch closes as the level of refrigerant in the freezer rises and opens as the level falls.

The float switch is connected to the “A” solenoid valve coil. This is the solenoid valve directly before the hand expansion valve. Therefore when the refrigerant level in the freezer drops, the float switch closes, thereby energizing and opening the “A” liquid feed solenoid until sufficient level has been reached to open the float switch. The float switch has a fixed 1/2” differential.

The float switch is installed at the correct height at the factory and should not need to be adjusted. The float switch is installed at the position that provides highest capacity. The correct height will produce compressor superheat, which climbs throughout the freeze cycle to a minimum of 30° F.

Hand Expansion Valve (9). The hand expansion valve is located directly after the “A” solenoid valve. This valve should be set at a point where the float switch is open for a length of time approximately equal to the time it is closed.

Solenoid Valves (18,25). All solenoid valves are pilot operated with “floating” type diaphragms. For satisfactory operation be sure that the manual opening stem is in the closed or automatic position. This means the stem is backed all the way out. Correct direction of stem rotation should be labeled on the stem seal nut.

Control Circuit Protection (CB1). The electrical control circuit of the machine is protected by a 3 amp circuit breaker. If breaker should open, the machine will immediately stop. Before resetting the breaker, check power to the machine and set the “On/Off” switch to the “off” position. If the machine was off for an extended time the crankcase heater must be energized for a minimum of two hours before restarting the machine. When ready to restart the machine, depress the “Start” button. The machine will automatically return to a freeze cycle upon completion of the harvest cycle.

Cutter Motor (3)/Gear Reducer (4). The gear reducer supplied requires no lubrication. It is lubricated from the original manufacturer for life. Do not attempt to lubricate the gear reducer. The motor bearings are also prelubricated and require no further lubrication.

Circulating Water Pump Motor (5). The motor bearings are prelubricated and sealed. They require no further lubrication. The pump should operate with the water level above the impeller

SERVICE OPERATIONS

housing to prevent cavitation or loss of prime. The pump is equipped with a mechanical seal which is self-adjusting and requires no lubrication. However, the pump should not be operated unless circulating water. The pump manufacturer recommends that a mechanical seal be kept as a spare. When ordering a seal, specify pump size, type, serial number, and manufacturer's name as indicated on the nameplate.

Pumpdown. The function of the pumpdown is to transfer all the liquid refrigerant from the freezer (evaporator) into the receiver. Pump-down should only be performed when the freezer is clear of ice. Its main purposes are:

1. To check the total refrigerant charge.
2. To perform service or repair work on the machine.
3. To winterize the machine.
4. To prepare the machine for disconnecting and moving.
5. Before cleaning

Pumpdown Procedure To perform a pumpdown, follow this procedure:

1. With the machine running, close the liquid feed stop valve nearest the receiver.
2. Open the water tank drain valve partially to allow a continuous flow of warm make-up water into the water tank and still maintain a good level in the tank. An auxiliary supply of warm water (not to exceed 100°F) may be used if available. Warmer water affords a more complete pumpdown.
3. Allow the machine to operate and complete two freeze and harvest cycles.
4. Stop the machine, throw the electrical disconnect, and lockout all power to the machine.
5. Remove wire from freezer pressure switch (if installed) and insulate the end to prevent a short circuit.
6. Restore power to machine and start the water pump (circulate warm water through the freezer).
7. When the suction pressure increases to 70 psig or higher, start the compressor and allow the machine to stop automatically by the low pressure switch at approximately 15 psig. (Lower pressure can be obtained by jumping out the pressure switch.) Remove all power from the machine before opening the control panel cover. With the pressure switch jumped out, the machine can be manually started and stopped. Do not operate the machine below 2 psig.
8. When the desired pumpdown is obtained, close the thawing gas stop valve, and the compressor discharge line stop valve. Other valves may also be closed to isolate a particular area that may require attention.
9. To perform a total pumpdown, it may be necessary to apply heat directly to the oil trap in order to boil off the liquid ammonia and oil mixture.

Removal of Ammonia Refrigerant from the Machine. Liquid ammonia can be removed from the machine through the receiver drain valve. Refer to Sections 1, 2 and Appendix A for special warnings and instructions regarding the handling of ammonia. Make sure you are familiar with and technically qualified to handle anhydrous-ammonia refrigerant.

! WARNING !
Approved recovery equipment, hoses, gages, and refrigerant containers must be used to comply with all local and federal EPA regulations.
! WARNING !

! WARNING !
Follow these instructions carefully. Severe personal injury can result from improper discharge of refrigerant.
! WARNING !

! WARNING !
It is not recommended that refrigerant be transferred from a refrigeration system into a cylinder. If such a transfer is made, the refrigerant cylinder must be an approved CLEAN cylinder-- free of any contaminants or foreign materials--and must be weighed continuously to assure contents do not exceed net weight specified by cylinder manufacturer or any applicable code requirements.
! WARNING !

If ammonia vapor is released from the machine, it may be purged into water, which will absorb it. Follow the purging instructions. See “Purging Non-condensables”.

Refrigerant Leaks. Anhydrous ammonia leaks can be detected by odor, sulfur stick, soap solution, or test paper. The odor is normally noticed first and the location of the leak is found with soap or sulfur stick. Soap solution can be purchased from your refrigeration supply house or it can be made by mixing four parts water, one part liquid soap, and a few drops of Glycerin for better capillary attraction.

- Apply soap solutions with a narrow brush or spray bottle to all joints, welds, or areas of suspicion. The solution will form bubbles if there is a leak.
- Light the end of the sulfur stick and pass it around suspected points of leakage. A white cloud will form where a leak is, even if it is very small.
- Moisten a strip of test paper and pass it around the suspected area. If the paper comes in contact with ammonia, it will turn red. Coils submerged in water, or condenser cooling water may be tested by dipping a strip directly in the water. If ammonia is present, the paper will turn red. Always remove refrigerant pressure from the vessel, tubing, or component part before repairs are attempted.

Note: Sulfur sticks and test paper can be obtained from your ammonia supplier.

SERVICE OPERATIONS

Non-condensable Gases. Satisfactory operation of the machine is not possible if non-condensable gases (usually air) are present in the system. Excessive condensing pressure is an indication of such gases. Excessive condensing pressure in water cooled condensers may also be due to the accumulation of scale in the cooling coil or due to insufficient cooling water or excessive water temperature. See “Water Cooled Condensers”, Section 7.

Purging Non-Condensables. Air and other non-condensable gases in a refrigeration system are not desirable. Purging air from your Tube-Ice[®] machine will greatly improve system performance and save money.

Non-condensable gas effects are:

1. Higher condensing pressure than desired.
2. Greater electrical power consumption.
3. Reduced refrigeration capacity.
4. Longer than normal compressor running time.
5. Slow ice release and long thaw cycle.

Air collects mostly in high pressure condensers, receivers, and other high-pressure components. It collects mostly in the coolest, lowest-velocity area of these components. Evaporative condensers usually have purge points at the top of the outlet header of each circuit. Receivers usually have a purge point at the top, away from the inlet, where it is coolest and the gas velocity is the lowest.

The freezer can be purged through the valve at the top of the suction line, but should be done only during the thaw cycle or after the system has been idle at least two hours.

Purging Procedure Follow this procedure when purging:

1. Connect a suitable hose to the purge valve and place the other end in water.
2. Open (slightly) the purge valve and allow air to escape.
3. Air will appear as bubbles in the water rising to the surface.
4. The larger the bubbles, the more air is escaping.
5. DO NOT leave the purge hose unattended.
6. When air bubbles are reduced to a minute size (smaller than 1/16), it can be considered that most of the air has escaped and purging can be ceased at this point.
7. Additional purging can be done at other purge points.
8. When purging is completed, close the valve, disconnect the hose, and install a plug in the purge valve.

Draining the Oil Trap. After many hours of operation, the oil which escapes the oil separator will pass through the receiver and to the freezer where it will settle in the oil trap (22). Indication of oil in the trap will be evident by the frost line. At the end of a freeze cycle, frost (or ice) will form on that part of the oil trap where oil is not present. When frost is seen only on the top 1/4 to 1/2 of the oil trap, the oil trap should be drained. Do not allow the oil trap to fill completely with oil, or it will cause loss of ice production and possible refrigerant floodback to the compressor.

Oil Trap Draining Procedure

1. Stop the machine and wait 12 hours or more.
2. Attach a suitable hose to the oil trap drain valve #61. Make sure there are no kinks or restrictions in the hose.
3. Open the valve slightly until oil begins to drain.
4. Continually observe the oil flow, being ready to close the valve quickly.

! DANGER !
Do not leave the oil trap drain valve opened or unattended--severe injury may result
! DANGER !

5. When a small amount of liquid ammonia begins to spew out, immediately close the valve.
6. Remove the hose and install a plug in the valve. DO NOT attempt to reuse any oil taken from the system unless it is properly reclaimed and meets the proper specifications.

Removing Excess Water from Ammonia

If excessive water is in the ammonia, it will cause frost on the suction line to the compressor, and dilution of the oil. This condition should not go uncorrected and the water needs to be removed.

Water Removal Procedure

1. Perform a total pumpdown of the freezer. See "Pumpdown" page 9-4.
2. A total pumpdown is accomplished when there is no frost or ice on the freezer or oil trap and the freezer pressure is below that pressure relative to the surrounding temperature. Refer to the Temperature-Pressure chart for ammonia.
3. With the freezer pressure below 25 PSIG, attach a hose to the oil trap drain valve and extend the other end into a container (5 gallon bucket, etc.).
4. Open the drain valve a little and drain out the oil and water that is present.
5. Continue to drain oil/water, and purge the freezer and compressor to 0 PSIG.

SERVICE OPERATIONS

6. Close the compressor discharge stop valve and the oil return valve. Make sure the power is disconnected and locked-out.
7. Drain the compressor oil, remove the compressor side cover and clean the inside of all oil and foreign matter, and reinstall the side cover.
8. Connect a vacuum pump, or pumps to the freezer and compressor, and evacuate them to 2000 microns or below while maintaining 60°F (10°C) or higher room temperature. A 5 CFM or larger vacuum pump is best.
9. During evacuation, add new oil to the compressor. Also purge the receiver for non-condensables.
10. After evacuation, break the vacuum by manually opening the liquid line solenoid valve and gradually opening the liquid line stop valve (24) or at the receiver, letting liquid ammonia enter the freezer and raise the pressure.
11. When the freezer (suction) pressure is up to at least 60 PSI, manually close the liquid line solenoid valve and restore power to the machine.
12. Open the compressor discharge valve, oil return valve, and all other valves that should be opened for normal operation.
13. When the receiver liquid level is near its normal operating level or the pressures are near equal and the compressor crankcase has warmed, the compressor can be started and ice production resumed.
14. After several cycles, check the system for symptoms of excessive water, and if necessary, repeat the pumpdown and evacuation procedure.

Note: whenever excessive water is present in the system, the source should be identified and corrections made prior to further operation.

Cutter Motor Removal/Replacement. The cutter motor's bearings are prelubricated and sealed and require no further lubrication. If the motor needs replacing, proceed as follows:

1. Turn power off and lock out disconnect.
2. Check terminals with volt meter to confirm power is off.
3. Remove motor terminal cover and disconnect wires. Mark wires for ease of replacement.
4. Remove four cap screws around the motor flange and separate the motor from the reducer. Watch for shaft key which must be reinstalled later.
5. Check the motor electrically to confirm it is defective.
6. Apply Anti-Seize lubricant to the shaft of the replacement motor.
7. Position the shaft key in the motor key-way, align it with the reducer key-way and install the motor. Make sure the key stays in.
8. Install the four cap screws to hold the motor in place on the reducer.
9. Connect the wires and install the terminal cover.
10. Check motor rotation to make sure the cutter turns in the proper direction. Reverse two wires at the motor if necessary to change rotation direction.

Cutter Gear Reducer Removal/Replacement. To remove the gear reducer, proceed as follows: Turn power off and lock-out disconnect.

1. Remove motor from reducer.
2. Loosen (slightly) the four bolts and nuts holding the gear reducer in place. Remove the four bolts holding the mounting plate to the water tank gear enclosure and remove the reducer and mounting plate from the tank.
3. Measure the distance between the top of drive gear and the mounting plate for future reference.
4. Remove the three cap screws from the gear and hub and install two 1/4"-20 x 2" long all thread set or cap screws in the threaded holes of the drive gear. These two screws can be used as jacking bolts to remove the gear from the tapered split hub.
5. In necessary, the split hub can be removed by driving a screw driver in the split and sliding the hub off the shaft.
6. The new gear reducer can then be installed by reversing the removal procedure.
7. Be sure the gear and hub is properly positioned on the shaft so it will have a full vertical mesh with the cutter ring gear.
8. Final gear meshing should be adjusted so there is only a slight amount of play between the ring gear and drive.
9. Make sure all bolts are tightened securely and there is no excessive gear noise when the cutter motor is running.

Water Tank Removal.

1. Turn off and lock out power to the machine.
2. Turn off water supply and disconnect lines from the tank.
3. Drain the tank and disconnect pump suction tube and drain line tubing and water lines.
4. Disconnect the ice discharge chute.
5. Loosen bolts holding the tank to the cutter assembly until the tank rests on the casters.
6. Remove cutter motor and gear reducer together. Hang on machine frame to support and secure.
7. Loosen bolts holding the tank supports.
8. The tank can then be removed to the side of the machine.
Make sure the rubber gasket is in place and aligned properly when the tank is reinstalled and bolted to the freezer.

SERVICE OPERATIONS

Cutter And Bearing Removal/Installation. Refer to FIGURES 9-3 & 9-4 for parts identification and location.

1. Turn off and lock out power to the machine.
2. Remove the cutter motor from the reducer.
3. Remove the water tank assembly and then the cutter assembly.
4. With a 1/4" or slightly smaller punch reach in through the ice discharge opening, drive the spiral pin out of the disc hub and cutter shaft, and push or drive the disc off the shaft.
5. Lift the cutter assembly out of the bearing surface of the cutter. The surface should be smooth and free from nicks or burrs.
6. Inspect the bearing for wear. There should be no side movement between the shaft and bearing and the bearing thrust flange should be no thinner than 3/16" (it is 1/4" thickness new).
7. Before removing the bearing, reference mark the location of the bearing support on the side of the tank.
8. Loosen and remove the three cap screws from the bearing support ends and lift the support out of the water tank.
9. Drive the 3/16" x 1/2" pin located in the side of the support hub in and through the bearing wall.
10. Now the bearing can be pressed or driven out of the support hub.
11. Try the new bearing on the cutter shaft to make sure it turns easily.
12. Press or drive the new bearing into the hub. Be careful not damage the bearing surfaces (the old bearing may be used as a driver).
13. Drill a 3/16" hole through the bearing wall, using the original hub hole as a pilot. Insert and drive the 3/16" pin flush with the outside of the hub, making sure the pin doesn't extend beyond the inner surface of the bearing.
14. Slide the new bearing and support onto the cutter shaft to make sure it spins freely. If it is tight, ream the bearing inner surface slightly until it turns free.
15. Install the bearing support in the tank, using the reference marks as a guide.
16. Slide the cutter and shaft into the bearing and check the cutter alignment. By laying a straight edge across the tank top flange, there should be 0" to 1/16" clearance between the rim of the cutter and the top of the tank flange. Loosen the bearing support cap screws and drive the support arms up or down for the proper alignment.
17. Tighten the support screws securely and finish assembly of the cutter and cutter disc.
18. Install the tank and other parts, reversing the procedure of removal.

ITEM NO.	QTY.	PART NO.	DESCRIPTION
1	1	12A2160H0101	HUB, CUTTER DRIVE GEAR
2	1	12A2215F1107	CAP SCREW, 1/4"-20 UNC X 5/8" SS HEX HEAD
3	3	12A2215F1112	CAP SCREW, 1/4"-20 UNC X 1 1/4" SS HEX HEAD
4	4	12A2215G111	SCREW, 5/16-18 UNC X 1" SS HEX HEAD CAP
5	4	12A2215H111	SCREW, 3/8"-16 UNC X 1" SS HEX HEAD CAP
6	3	12A2215H1208	SCREW, 3/8"-24 NF X 3/4" SS HEX HEAD CAP
7	4	12A2226F1112	MACHINE SCREW, FLAT HEAD SS, 1/4 X 1 1/4
8	4	12A2240A1108	NUT, 5/16-18 UNC SS FULL HEX
9	6	12A2240A1307	NUT, HEX 1/4"-20NC S.S. (HEAVY)
10	1	12A2250A107	CUT WASHER, 1/4" SS
11	4	12A2250A108	CUT WASHER 5/16" SS
12	3	12A2250A12	WASHER, CUT 3/8" SS
13	6	12A2250B107	LOCK WASHER, 1/4" SS
14	4	12A2250B108	LOCK WASHER, 5/16" SS
15	1	12A2615D01	DRIVE GEAR TI-59 W/O HUB SMALL & MID SIZE MACH.
16	1	12A2900M0508	MOTOR, 1/2 HP, 208/230-3-60
17	1	12A3040S01	PIN, SPRING, 1/4" DIA. X 1 1/2" LONG, TYPE 304 SS
18	1	12A3040S02	PIN, SPRING, 3/16 DIA. X 1/2" LONG, TYPE 304 SS
19	1	12A3050S0401	PIPE NIPPLE 3/4" ALL THREAD, TYPE 304 S.S.
20	1	12A4030R15	GEAR REDUCER, IN-LINE, 10:1
21	1	12A4078C04	SPLASH CURTAIN
22	4	12A4130S02	SPACER, ADAPTOR PLATE
23	1	12A4200A0607	VALVES, SOLENOID, 3/4 FPT, WITH 208-240V 50/60HZ COIL
24	1	12A4200G0807	VALVES, BALL 1" NPT STAINLESS STEEL
37A	1	12A4200H0402	VALVE, FLOAT, 1/2"MPT, LOCKNUT & GASKET
37B	1	12A4200HP01	FLOAT STEM, BRASS, 10" LONG, 1/4-20 THRD BOTH ENDS
37C	1	12A4200HP02	FLOAT, 1/4-20 THRD
26	1	12B2020R01	UHMW CUTTER BEARING
27	1	19T2024B0101	BEARING SUPPORT BRACKET
28	1	19T2160C0202	CUTTER ASSEMBLY, WITH CAST CUTTER
29	1	19T2163D0202	CUTTER DISC ASSEMBLY
30	1	19T4001S0642	FLOAT BOX COVER
31	1	19T4500S1809	WATER TANK ASSEMBLY
31A	1	19T4001S0230	ICE DEFLECTOR PLATE
31B	1	19T4500S1809	GEAR REDUCER MOUNTING ASSEMBLY
31C	6	12A2215F1107	CAP SCREW, 1/4"-20 UNC X 5/8" SS HEX HEAD
31D	6	2A2240A1107	NUT, 1/4-20 UNC SS FULL HEX
31E	6	12A2250A107	CUT WASHER, 1/4" SS
31F	6	12A2250B107	LOCK WASHER, 1/4" SS
32	1	19T4001S0423	SPLASH CURTAIN MOUNTING PLATE
33	1	19T2010A12	ADAPTOR PLATE, ICE LENGTH, USED WITH CAST CUTTER

TABLE 9-1
Cutter/Water Tank Parts List

SERVICE OPERATIONS

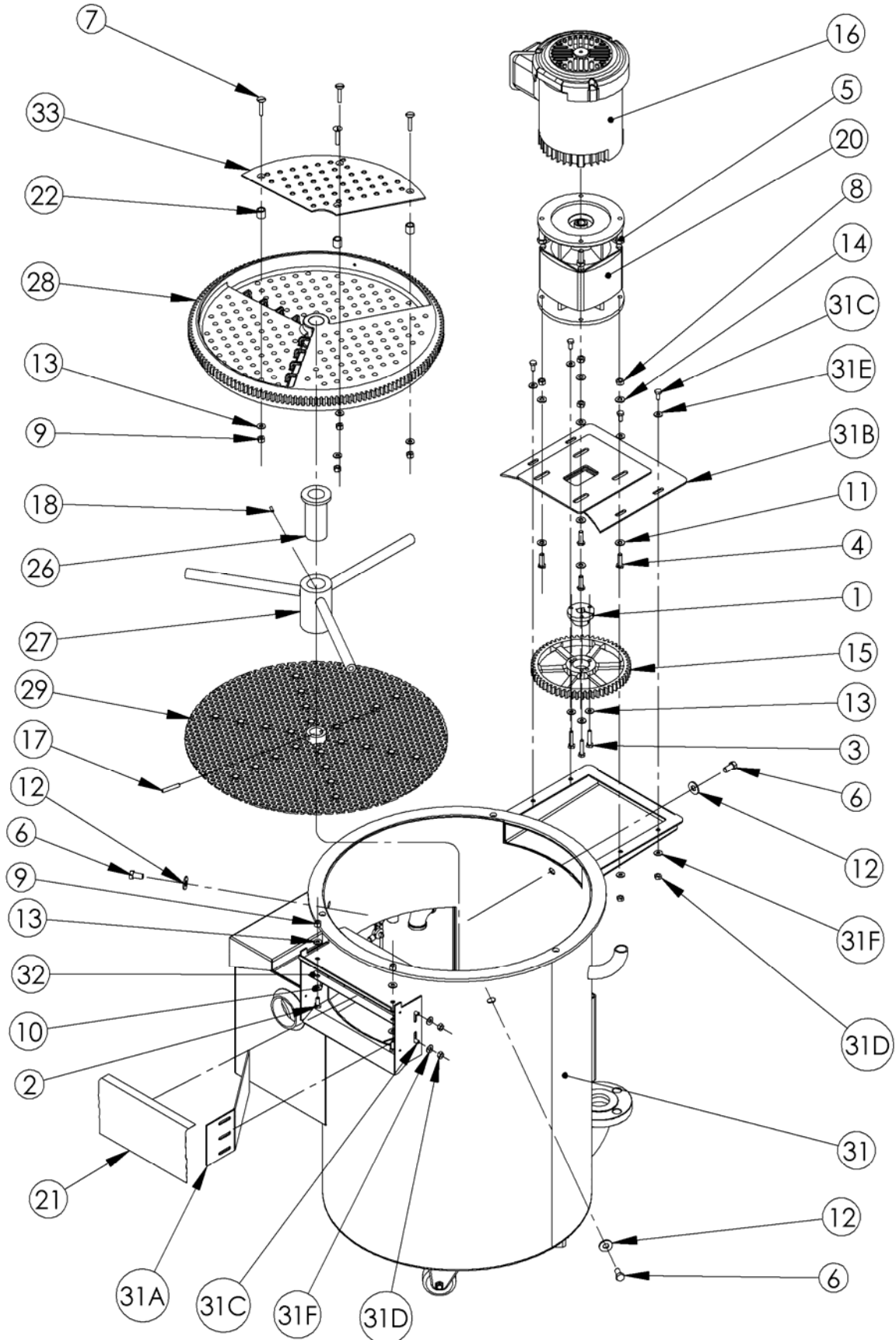

FIGURE 9-3
Cutter/Water Tank Assembly

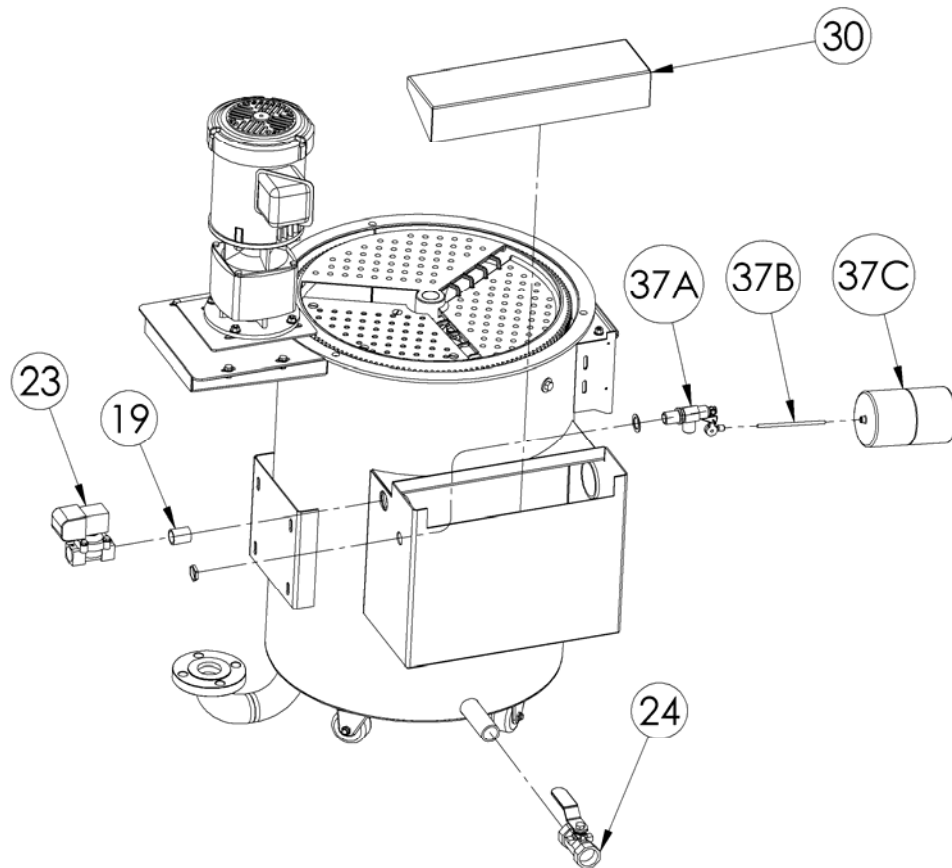

FIGURE 9-4
Cutter/Tank Parts

Crushed Ice Production. Your P18AL Tube-Ice[®] machine is capable of producing crushed ice with no loss of capacity. However, there are certain changes to be made in order to convert to crushed ice production:

Add:

1. Cutter Assembly (12A6413A).
2. Cutter Motor 3/4 HP (12A2900M0601 – 60 Hz) or 1 HP (12A2900M0603 – 50 Hz).
3. Gear Reducer 5:1 Ratio (12A4030R12)
4. Motor Starter (12A7530E55 – 208/230V, 60 Hz), (12A7530E54 – 460V, 60 Hz), (12A7530E56 – 200V, 50 Hz) or (12A7530E54 – 400V, 50 Hz)

Change:

1. Raise the freezer pressure switch setting to make ice 3/16" thick (average).
2. Reverse cutter direction.
3. Reverse deflector.

Two people should normally accomplish this conversion process in 6-8 hours (or less). There must be ample room around the machine for the water tank removal. It is recommended that you have good quality water when attempting to produce crushed ice. If the ice is opaque and cloudy, it is subject to clog the cutter mechanism restrict ice discharge and bind the cutter. Also, you should not attempt to produce crushed ice when the make-up water temperature is below 50°F (10°C). Colder water can cause a build-up of ice fines in the tank and eventually result in "short-cycling".

10. Tables & Charts

TABLES & CHARTS

P18AL SPECIFICATIONS (60 Hz)

Tube Size	inches (cm)	1 (2.54)	1 1/4 (3.17)	1 1/2 (3.18)
Nominal Capacity	lbs/day (Kg/day)	See Table 11-3	See Table 11-4	See Table 11-5
Overall Dimensions (LxWxH)	inches (meters)	38 x 38 x 133 (.97x.97x3.4)	38 x 38 x 133 (.97x.97x3.4)	38 x 38 x 133 (.97x.97x3.4)
Shipping Weight	lbs (Kg)	3300 (1497)		
Operating Weight	lbs (Kg)	3850 (1746)		
Refrigerant Charge (R-717)⁽¹⁾	lbs (Kg)	244 (111)	239 (108)	236 (107)
Total FLA⁽²⁾		8.3		
Maximum Fuse		10		
Minimum Ampacity		9.8		
System Requirements				
Dedicated Compressor⁽³⁾				
-Average Refrigeration	Tons (KW)	28.3 (99.5)	18.7 (65.7)	16.1 (56.6)
Central System⁽³⁾				
-Average Refrigeration	Tons (KW)	See Table 11-3	See Table 11-4	See Table 11-5
-makeup water⁽⁴⁾	gpm (m ³ /Hr)	3.0 (0.68)	3.0 (0.68)	3.0 (0.68)
-blowdown	gpm (m ³ /Hr)	10 (2.27)	10 (2.27)	10 (2.27)
Connection Sizes				
-makeup water	FPT	1/2"		
-tank drain	FPT	1"		
-flush solenoid valve	FPT	3/4"		
-overflow	FPT	2"		
Compressor -HP/KW/FLA	HP/KW/FLA	30 / 22.4 / 105 (minimum required)		
Water Pump -HP/KW/FLA	HP/KW/FLA	2.0 / 2.6 / 5.6		
Cutter Motor -HP/KW/FLA	HP/KW/FLA	0.5 / 0.7 / 1.9		
THR (at pulldown)	Btu/hr (kW)	421,820 (124)	301,725 (88.4)	219,692 (64.4)
THR (average)	Btu/hr (kW)	337,456 (98.8)	241,380 (70.7)	175,754 (51.3)

Vogt reserves the right to change designs and specifications without notice.

- (1) Refrigerant charge is for low side unit only. Additional refrigerant required for high side and piping.
(2) Compressor requirement is based on 70°F makeup water, 14°F suction temperature, 100°F condensing temperature, 70°F ambient, and 25 gal/cycle blowdown. Compressor rpm's vary.
(3) FLA for 460 volt models is approximately 1/2 that of 230 volt models. Total FLA does not include cooling tower.
(4) Makeup water is maximum value. Actual usage may vary.

Table 10-1

P18AL Capacity Ratings (7/8" Diameter Ice)

Suction Pressure (psig)	35	33	40	28	25	24	20	20	16
Suction Temp. (°F)	21.4	20.0	16.6	15.0	11.3	10.0	5.5	5.0	0.0
*Avg. Ref. Required (tons)	14.7	16.2	19.6	21.1	24.3	25.4	28.9	29.2	32.7
Compressor Capacity	17.3	19.4	24.5	26.9	32.4	34.3	41.1	41.8	49.3
Make-Up Water Temp (°F)	ICE CAPACITY (tons/24 hrs)								
95	6.8	7.6	9.2	9.9	11.5	12.0	13.8	13.9	15.7
90	7.0	7.8	9.4	10.2	11.8	12.3	14.1	14.3	16.0
85	7.2	8.0	9.7	10.4	12.1	12.6	14.4	14.6	16.4
80	7.4	8.2	9.9	10.7	12.4	13.0	14.8	15.0	16.8
75	7.7	8.4	10.2	11.0	12.7	13.3	15.1	15.3	17.2
70	7.9	8.7	10.5	11.3	13.1	13.7	15.5	15.7	17.6
65	8.2	9.0	10.8	11.7	13.4	14.0	15.9	16.1	18.0
60	8.4	9.3	11.2	12.0	13.8	14.4	16.4	16.6	18.5
55	8.7	9.6	11.5	12.4	14.2	14.9	16.8	17.0	19.0
50	9.0	9.9	11.9	12.8	14.7	15.3	17.3	17.5	19.5

*Average Refrigeration Required is for central plant operation and the tabulated value is based on 70° make-up water.

**Table 10-2
Capacity Ratings for 1" Tube**

P18AL Capacity Ratings (1 1/8" Diameter Ice)

Suction Pressure (psig)	35	33	40	28	25	24	20	20	16
Suction Temp. (°F)	21.4	20.0	16.6	15.0	11.3	10.0	5.5	5.0	0.0
*Avg. Ref. Required (tons)	10.2	11.3	13.9	15.0	17.5	18.4	21.2	21.5	24.4
Compressor Capacity	11.4	12.8	16.1	17.7	21.3	22.6	27.0	27.5	32.4
Make-Up Water Temp (°F)	ICE CAPACITY (tons/24 hrs)								
95	4.8	5.3	6.5	7.1	8.3	8.7	10.1	10.3	11.7
90	4.9	5.5	6.7	7.3	8.5	9.0	10.4	10.5	12.0
85	5.1	5.6	6.9	7.5	8.8	9.2	10.7	10.8	12.3
80	5.2	5.8	7.1	7.7	9.0	9.5	10.9	11.1	12.6
75	5.4	6.0	7.3	7.9	9.3	9.7	11.2	11.4	13.0
70	5.6	6.2	7.6	8.2	9.6	10.0	11.6	11.7	13.3
65	5.8	6.4	7.8	8.4	9.9	10.3	11.9	12.1	13.7
60	6.0	6.6	8.1	8.7	10.2	10.7	12.3	12.4	14.1
55	6.2	6.8	8.3	9.0	10.5	11.0	12.7	12.8	14.5
50	6.4	7.1	8.6	9.3	10.9	11.4	13.1	13.2	15.0

*Average Refrigeration Required is for central plant operation and the tabulated value is based on 70° make-up water.

**Table 10-3
Capacity Ratings for 1 1/4" Tube**

TABLES & CHARTS

P18AL Capacity Ratings (1 3/8" Diameter Ice)

Suction Pressure (psig)	35	33	40	28	25	24	20	20	16
Suction Temp. (°F)	21.4	20.0	16.6	15.0	11.3	10.0	5.5	5.0	0.0
*Avg. Ref. Required (tons)	7.3	8.1	10.0	10.9	12.9	13.5	15.7	16.0	18.3
Compressor Capacity	7.9	8.8	11.2	12.2	14.8	15.6	18.7	19.0	22.4
Make-Up Water Temp (°F)	ICE CAPACITY (tons/24 hrs)								
95	3.4	3.8	4.7	5.2	6.1	6.4	7.5	7.6	8.8
90	3.5	3.9	4.9	5.3	6.3	6.6	7.7	7.8	9.0
85	3.6	4.1	5.0	5.5	6.5	6.8	7.9	8.1	9.3
80	3.8	4.2	5.2	5.6	6.6	7.0	8.2	8.3	9.5
75	3.9	4.3	5.3	5.8	6.9	7.2	8.4	8.5	9.8
70	4.0	4.5	5.5	6.0	7.1	7.4	8.7	8.8	10.1
65	4.2	4.6	5.7	6.2	7.3	7.7	8.9	9.1	10.4
60	4.3	4.8	5.9	6.4	7.5	7.9	9.2	9.4	10.7
55	4.5	5.0	6.1	6.6	7.8	8.2	9.5	9.7	11.1
50	4.6	5.2	6.3	6.9	8.1	8.5	9.9	10.0	11.4

*Average Refrigeration Required is for central plant operation and the tabulated value is based on 70° make-up water.

Table 10-4
Capacity Ratings for 1 1/2" Tube

Make-Up Water Temp (°F)	Cylinder Ice Tube Size			Crushed Ice Tube Size		
	1"	1 1/4"	1 1/2"	1"	1 1/4"	1 1/2"
90	1.93	1.74	1.68	2.25	2.02	1.94
89	2.14	1.93	1.86	2.49	2.25	2.16
70	2.35	2.12	2.04	2.74	2.47	2.38
60	2.42	2.16	2.09	2.84	2.53	2.43
50	2.49	2.21	2.14	2.92	2.58	2.49
40	2.56	2.25	2.19	3.00	2.62	2.54

Table 10-5
Make-Up Water Usage (gpm)

**Normal Operating Vitals
P18AL**

			Suction Pressure (psig)		Discharge Pressure (psig)		Harvest Times (secs)			Ice per cycle Average (lbs)	Freeze Time (minutes)				
			End of Freeze	End of Thaw	End of Freeze	End of Thaw	First Ice	All Ice Out	Total Harvest		Water Temperature (deg. F)				
										90	80	70	60	50	
60 HZ	C	1"	25	53	180	66	40	120	160	235	13.4	12.5	11.7	10.8	10.0
	Y	1 1/4"	22	54	180	70	40	120	160	245	17.5	15.5	13.5	13.0	12.0
	L	1 1/2"	18	54	190	65	40	120	160	235	24	22	21.5	21	20
	C	1"	32	56	175	63	40	120	160	175	12.0	11.2	10.3	9.4	8.9
	R	1 1/4"	29	54	180	54	40	120	160	175	12.6	11.6	10.8	10.1	9.4
	U	1 1/2"	25	53	180	66	40	120	160	175	16.2	15.3	14.5	13.7	12.7
50 HZ	C	1"	25	53	180	66	40	120	160	235	13.4	12.5	11.7	10.8	10.0
	Y	1 1/4"	22	54	180	70	40	120	160	245	17.5	15.5	13.5	13.0	12.0
	L	1 1/2"	18	54	190	65	40	120	160	235	24	22	21.5	21	20
	C	1"	32	56	175	63	40	120	160	175	12.0	11.2	10.3	9.4	8.9
	R	1 1/4"	29	54	180	54	40	120	160	175	12.6	11.6	10.8	10.1	9.4
	U	1 1/2"	25	53	180	66	40	120	160	175	16.2	15.3	14.5	13.7	12.7

**Table 10-6
Usual Operating Conditions**

**RECOMMENDED SPARE PARTS LIST
Vogt Model P18AL Tube-Ice® Machine**

QTY	PART NUMBER	DESCRIPTION
1	12A-7503E52	Freeze Timer
1	12A-7503E22	Thawing Timer
1	12A-7517E28	CR Relay, 208/230V, 50/60 Hz.
1	12A-7516E23	Starter Contactor, 208/230V, 50/60 Hz.
1	12A-7530E54	CU Starter, 208/230V, 50/60 Hz.
1	12A-7530E56	P Starter, 208/230V, 50/60 Hz.
1	12A-2900M0501	Cutter Motor, 1/2 HP
2	12A-4200H0402	Make-up Water Float Valve
1	12B-2020R01	Cutter Bearing
1	12A-2600G07	Gasket, Freezer Cover
1	12A-2600G05	Gasket for water tank
1	12C-2590G17	Freezer and Thaw Gas Pressure Gage
1	12A-7500E22	Float Switch
1	12-6229	Coil (Hansen Solenoid Valve)

TO ORDER SPARE PARTS, PLEASE CONTACT YOUR DISTRIBUTOR.

TABLES & CHARTS

**TEMPERATURE - PRESSURE CHART
FOR COMMON REFRIGERANTS**

DegF	R-12	R-22	R-502	R-134a	R-404A	R-717	MP-39	DegF	R-12	R-22	R-502	R-134a	R-404A	R-717	MP-39
-50	-7.6	-3.0	0.2	-9.0	0.0	-7.0	-9.1	50	46.7	84.0	97.4	45.5	102.9	74.2	45.3
-48	-7.2	-2.4	0.7	-8.7	0.8	-6.5	-8.7	52	48.8	87.3	101.0	47.7	109.0	77.7	60.0
-46	-6.8	-1.7	1.5	-8.3	1.6	-6.0	-8.3	54	51.0	90.8	104.8	50.1	113.0	81.3	62.0
-44	-6.3	-1.0	2.3	-8.0	2.5	-5.4	-7.9	56	53.2	94.3	108.6	52.3	117.0	84.9	65.0
-42	-5.8	-0.2	3.2	-7.6	3.4	-4.9	-7.4	58	55.4	97.9	112.4	55.0	121.0	88.7	68.0
-40	-5.4	0.5	4.1	-7.1	5.5	-4.3	-7.1	60	57.7	101.6	116.4	57.5	125.0	92.6	70.0
-38	-4.9	1.3	5.0	-6.7	6.5	-3.6	-6.6	62	60.1	105.4	120.4	60.1	130.0	96.6	73.0
-36	-4.4	2.2	6.0	-6.3	7.5	-3.0	-6.1	64	62.5	109.3	124.6	62.7	134.0	100.7	76.0
-34	-3.8	3.0	7.0	-5.8	8.6	-2.3	-5.6	66	65.0	113.2	128.8	65.5	139.0	104.9	79.0
-32	-3.3	4.0	8.1	-5.3	9.7	-1.6	-5.2	68	67.6	117.3	133.2	68.3	144.0	109.3	82.0
-30	-2.7	4.9	9.2	-4.8	10.8	-0.8	-4.4	70	70.2	121.4	137.6	71.2	148.0	113.7	85.0
-28	-2.1	5.9	10.3	-4.2	12.0	0.0	-4.1	72	72.9	125.7	142.2	74.2	153.0	118.3	89.0
-26	-1.5	6.9	11.5	-3.8	13.2	0.8	-3.4	74	75.6	130.0	146.8	77.2	158.0	123.1	92.0
-24	-0.8	7.9	12.7	-3.0	14.5	1.7	-2.9	76	78.4	134.5	151.5	80.3	164.0	127.9	95.0
-22	-0.1	9.0	14.0	-2.4	15.8	2.6	-2.2	78	81.3	139.0	156.3	83.5	169.0	132.8	99.0
-20	0.6	10.1	15.3	-1.8	17.1	3.5	-1.7	80	84.2	143.6	161.2	86.8	174.0	137.9	102.0
-18	1.3	11.3	16.7	-1.1	18.5	4.5	-1.0	82	87.2	148.4	166.2	90.2	180.0	143.2	106.0
-16	2.1	12.5	18.1	-0.4	20.0	5.6	-0.2	84	90.2	153.2	171.4	93.6	185.0	148.5	109.0
-14	2.8	13.8	19.5	0.3	21.5	6.7	0.4	86	93.3	158.2	176.6	97.1	191.0	154.1	113.0
-12	3.7	15.1	21.0	1.1	23.0	7.8	1.4	88	96.5	163.2	181.9	100.7	197.0	159.7	117.0
-10	4.5	16.5	22.6	1.9	24.6	8.9	2.2	90	99.8	168.4	187.4	104.4	203.0	165.5	121.0
-8	5.4	17.9	24.2	2.8	26.3	10.2	3.1	92	103.1	173.7	192.9	108.2	209.9	171.4	125.0
-6	6.3	19.3	25.8	3.6	28.0	11.4	3.9	94	106.5	179.1	198.6	112.1	215.0	177.5	129.0
-4	7.2	20.8	27.5	4.5	29.8	12.8	4.8	96	110.0	184.6	204.3	116.1	222.0	183.7	133.0
-2	8.2	22.4	29.3	5.5	31.6	14.2	5.7	98	113.5	190.2	210.2	120.1	229.0	190.1	138.0
0	9.2	24.0	31.1	6.5	33.5	15.6	6.7	100	117.2	195.9	216.2	124.3	235.0	196.1	142.0
2	10.2	25.6	32.9	7.5	35.6	17.1	7.7	102	120.9	201.8	222.3	128.5	242.0	203.3	146.0
4	11.2	27.3	34.9	8.5	37.4	18.6	8.8	104	124.7	207.7	228.5	132.9	249.0	210.2	151.0
6	12.3	29.1	36.9	9.6	39.4	20.3	9.9	106	128.5	213.8	234.9	137.3	256.0	217.2	156.0
8	13.5	30.9	38.9	10.8	41.6	21.9	11.0	108	132.4	220.0	241.3	142.8	264.0	224.4	160.0
10	14.6	32.8	41.0	12.0	43.9	23.7	12.2	110	136.4	226.4	247.9	146.5	271.0	231.7	165.0
12	15.8	34.7	43.2	13.1	46.0	25.4	13.4	112	140.5	232.8	254.6	151.3	279.0	239.2	170.0
14	17.1	36.7	45.4	14.4	48.3	27.4	14.6	114	144.7	239.4	261.5	156.1	286.0	246.9	175.0
16	18.4	38.7	47.7	15.7	50.7	29.3	15.9	116	148.9	246.1	268.4	161.1	294.0	254.8	180.0
18	19.7	40.9	50.0	17.0	53.1	31.3	17.2	118	153.2	252.9	275.5	166.1	302.0	262.8	185.0
20	21.0	43.0	52.5	18.4	55.6	33.3	18.6	120	157.7	259.9	282.7	171.3	311.0	271.0	191.0
22	22.4	45.3	54.9	19.9	58.2	35.5	20.0	122	162.2	267.0	290.1	176.6	319.0	279.4	196.0
24	23.9	47.6	57.5	21.4	59.9	37.7	21.5	124	166.7	274.3	297.6	182.0	328.0	288.0	202.0
26	25.4	49.9	60.1	22.9	63.6	40.0	23.0	126	171.4	281.6	305.2	187.5	336.0	296.7	207.0
28	26.9	52.4	62.8	24.5	66.5	42.4	24.6	128	176.2	289.1	312.9	193.1	345.0	305.7	213.0
30	28.5	54.9	65.6	26.1	69.4	44.8	26.2	130	181.0	296.8	320.8	198.9	354.0	314.8	219.0
32	30.1	57.5	68.4	27.8	72.3	47.4	27.9	132	185.9	304.6	328.9	204.7	364.0	324.2	225.0
34	31.7	60.1	71.3	29.5	75.4	50.0	29.6	134	191.0	312.5	337.1	210.7	373.0	333.7	231.0
36	33.4	62.8	74.3	31.3	78.5	52.7	31.3	136	196.2	320.6	345.4	216.8	383.0	343.4	237.0
38	35.2	65.6	77.4	33.2	81.8	55.5	33.2	138	201.3	328.9	353.9	223.0	392.0	353.4	243.0
40	36.9	68.5	80.5	35.1	85.1	58.4	35.0	140	206.6	337.3	362.6	229.4	402.0	363.5	250.0
42	38.8	71.5	83.8	37.0	88.5	61.3	37.0	142	212.0	345.8	371.4	235.8	412.0	373.8	256.0
44	40.7	74.5	87.0	39.1	91.9	64.4	39.0	144	217.5	354.5	380.4	242.4	423.0	384.4	263.0
46	42.7	77.6	90.4	42.0	95.5	67.6	41.0	146	223.1	363.4	389.5	249.2	434.0	395.2	269.0
48	44.7	80.7	93.9	43.3	99.2	70.8	43.1	148	228.8	372.3	398.9	256.0	444.0	406.1	277.0
50	46.7	84.0	97.4	45.5	102.9	74.2	45.3	150	234.6	381.5	408.4	263.0	449.0	432.0	283.0

TABLE 10-7
All pressures are in lbs/in² gage (psig).

REFERENCE INFORMATION

CONVERSION FACTORS: English to Metric

To Convert	From	To	Multiply by
Area	ft ²	m ²	9.2903e-2
	in ²	m ²	6.416 e-4
Energy	BTU	Joule (J)	1054.48
	hp	BTU/Hr	2546.2
	kW	hp	1.34
Length	ft.	m.	0.3048
	in.	m.	0.0254
Pressure	lbf/ft ²	Paschals	47.88
	lbf/in ² (psi)	Paschals	6894.76
	in. Hg	psi	0.491
	in H ₂ O	psi	0.03612
Temperature	°F	°C	$T_C = 5/9 * (T_F - 32)$
	°C	°F	$T_F = (9/5 * T_C) + 32$
Volume	ft ³	m ³	2.8317e-2
	gal(U.S.)	m ³	3.7854e-3
	ft ³	gal(U.S.)	7.48

TABLE 10-8

CONSTANTS

Specific heat of Water	1 BTU/(lbm °F)
Specific heat of Air	4.19 kJ/(kg °C) 0.24 BTU/(lbm °F)
Tube-Ice Density	32-35 lbs/ft ³
Ice Latent Heat	144 BTU/hr
Water Sensible Heat	1 BTU/(lb °F)
Ice Melting Effect (IME) 1 Ton Refrigeration	12,000 BTU/hr
Atmospheric pressure	14.7 psia
Weight of Water	62.4 lbs/ft ³ 8.33 lbs/gal
1 gpm water	12013 lb/day
Weight of air	0.0749 lbs/ft ³ 0.0100 lbs/gal
1 Horsepower	2545.6 BTU/hr
1 Kilowatt	1.34 horsepower
Gravitational accel.	9.81 m ² /sec

TABLE 10-9

11. Index

A

A-Valve ----- 4-1, 5-1
 Accumulator ----- 4-1, 5-1
 Adding Refrigerant ----- 5-2
 Ammonia - Specification by Grade ----- 5-2
 Ammonia – Machine Charge ----- 5-2
 Ammonia - Removal ----- 9-5

B

Basic Product Warranty ----- inside back cover
 Bearing, Cutter ----- 9-10
 Bill of Lading ----- 2-1
 Bin, Level Control ----- 6-1, 8-2
 Blowdown ----- 3-3

C

Capacity Ratings ----- 2-2, 10-2 –10-4
 Centrifugal Pump ----- 9-4
 Charging Refrigeration Systems ----- 1-2, 5-2
 Checklist, Daily ----- 7-2
 Checklist, Installation Review ----- 3-11
 Chemical Cleaning ----- 7-5
 Circuit Breaker, Cutter ----- 6-3
 Circuit Breaker, Pump ----- 6-3
 Circulating Water Pump Motor ----- 9-4
 Clean/Off/Ice Selector Switch ----- 5-5, 6-1
 Cleaning Procedure ----- 7-3
 Compressor ----- 7-7
 Compressor Crankcase Heater ----- 3-11
 Compressor Lubrication ----- 7-7
 Compressor Unloading ----- 3-4
 Condenser Cleaning ----- 7-5
 Condenser, Water Cooled Maintenance ----- 7-5
 Control Circuit Protection ----- 9-3
 Control Panel ----- 6-2-6-3
 Control Panel Parts ----- 6-2-6-3
 Control, Relay (CR) ----- 6-3
 Cooling Tower ----- 3-4, 7-7
 Crankcase Heater ----- 3-11, 7-3
 Crushed Ice Production ----- 9-13
 Cutter & Bearing Removal/Installation ----- 9-10, 9-12
 Cutter Drive Parts ----- 9-12
 Cutter Gear Reducer ----- 7-5, 9-9, 9-12
 Cutter Motor ----- 9-3, 9-9, 9-12
 Cutter, Assembly ----- 9-12
 Cutter, Bearing ----- 9-12
 Cutter, Bearing Support ----- 9-12
 Cutter, Disc Assembly ----- 9-12
 Cutter, Drive Parts ----- 9-12
 Cutter, Gear Reducer ----- 9-9, 9-12
 Cutter, Motor ----- 9-9, 9-12
 Cutter/Water Tank Assembly ----- 9-12
 Cutter/Water Tank Parts (crushed Ice) ----- 9-13
 Cutter/Water Tank Parts (cylinder ice) ----- 9-12

D

D Valve (Thawing Gas) ----- 4-1, 4-2
 Daily Check List ----- 7-1
 Drive gear ----- 9-11

E

Electrical Connections, Customer ----- 3-9
 Electrical Schematic All Voltages 50-60 Hz. ----- 6-5
 Electrical, Controls ----- 6-2
 Enclosure ----- 6-2
 Energy Saving ----- 1-1

F

Float Switch ----- 1-7, 9-3
 Float Valve (Make-Up Water) ----- 9-3
 Foundation Layout ----- 3-2
 Freeze Period ----- 4-2
 Freeze Timer ----- 4-2, 9-1
 Freeze-Up Due To Extended Freezing Period ----- 8-3
 Freeze-Up Due To Ice Failing To Discharge ----- 8-3
 Freezer ----- 4-1

G

Gear Reducer ----- 9-10

H

Hand Expansion Valve ----- 1-5, 5-1
 Harvest Period ----- 4-2
 Heater, Crankcase ----- 3-11, 7-3
 High Head Pressure ----- 8-5
 High Head Pressure ----- 8-5
 High/Low Pressure Switch ----- 6-1
 History, Tube-Ice® ----- 1-1
 Hub, Cutter Drive Gear ----- 9-12

I

Ice Capacity ----- 10-2 – 10-4
 Ice-Making Section ----- 7-3
 Important Safety Notice ----- 1-2
 Inspection, First Arrival ----- 2-1
 Installation ----- 3-1
 Installation Review: A Checklist ----- 3-11
 Introduction ----- 1-1

J, K

L

Low Compressor Oil Level ----- 8-6
 Low Ice Capacity ----- 8-4
 Low Pressure Switch ----- 6-1
 Lubrication ----- 7-6
 Lubrication, Compressor ----- 7-7
 Lubrication, Cutter Gear Reducer ----- 7-5

INDEX

M

Machine Ratings	10-3 – 10-4
Machine Room	3-1
Machine Won't Run	8-2
Maintenance Program	7-1
Maintenance Program Form	7-2
Make-Up Water	3-2 – 3-3, 10-4
Manual Harvest Push Button	5-7, 6-4
Metric Conversion	10-7

N

NEMA	3-1
Nomenclature, Piping Schematic	4-2
Non-Condensable Gases	9-6
Normal Operating Vitals	10-6

O

Operating Tips	5-7
Operation Vitals	10-5

P

Pin, Stainless Steel	9-11
Piping and Drain Connections	3-2
Piping Schematic, Central System	4-4
Piping Schematic, Dedicated High-Side	4-3
Piping Schematic, Nomenclature	4-2
Poor Ice Quality	8-5
Power Connection	3-9
Preventive Maintenance	7-2
Preventive Maintenance Program	7-1
Preview	1-1
Principle of Operation	4-1
Pump Down	9-4
Pump Starter	6-3
Pump, Contactor	6-3

Q**R**

R-717 (Anhydrous Ammonia)	1-2, 2-1, 5-1, 9-5
Receipt of Machine	2-1
Receiver	3-3
Recommended Spare Parts List	10-5
Refrigerant Charge	3-6, 5-2
Refrigerant Leaks	9-5
Refrigerant, Leaks	5-1
Refrigerant, Removal	9-5
Refrigeration System Review	5-1
Rotation Check	3-10

S

Safety Notice	1-2
Safety Symbols and What They Mean	1-3
Safety Valves	2-2
Shipping Papers	2-1
Solenoid Valve	9-3
Space and Connection Diagram	3-5
Special Precautions	1-2

Start Push Button (PB1)	5-5, 6-2
Starter, Cutter Motor	6-3
Starter, Pump Motor	6-3
Start-Up	5-5
Start-Up Checklist	3-11
Suction Cut-Off Unloader	9-14
Symptoms, Troubleshooting	8-1

T

Telephone Number, Vogt	1-1
Temperature-Pressure Chart	10-6
Thawing, Chamber	4-1
Thawing, Timer (T)	6-3, 9-1
Timer, Thawing	6-3, 9-1
Troubleshooting	8-1

U

Unloading Compressor	3-4
----------------------	-----

V

Vitals, Operation	10-5
-------------------	------

W

Warranty (Basic Product)	inside back cover
Water Conditioning	3-3
Water Cooled Condenser	7-5
Water Cooled Condenser Cleaning	7-5
Water Distributors	7-4
Water Pump Motor	9-4
Water Quality	3-1
Water Supply and Drain Connections	3-2
Water Tank	7-4
Water Tank Removal	9-9
Water Usage, Make-up	10-4
Wiring and Electrical Connection	3-9
Wiring Schematic, All Voltages - 50/60 Hz	6-5

X, Y, Z

Vogt® Tube-Ice® Machine
MID & LARGE MACHINE WARRANTY REGISTRATION/START-UP REPORT
 MUST COMPLETE AND RETURN TO INITIATE WARRANTY

Machine Model No. _____ Serial No. _____

Installed at: _____ () _____
 Company Name Phone

 Address City State Zip

Installed by: _____ () _____ / ____ / ____
 Company Name Phone Date

 Address City State Zip

Describe any damage to machine/repairs made: _____

Start up by: _____ () _____ / ____ / ____
 Company Name Phone Date

 Address

Name of person starting up machine: _____

PRE START-UP CHECK

CHECK

- Service Manual on hand
- Machine room suitable 50°F minimum, 110°F maximum
- Proper power supply, actual voltage _____, _____ (machine not running)
- Compressor crankcase heater on 12 hour minimum
- Necessary hand valves opened as required
- Solenoid valve stems in auto position
- System leak checked/tight
- Auxiliary equipment overloads wired into control circuit
- Compressor oil level _____ (1/4 glass min.)
- All water distributors in place (visually inspected)
- Water supply and drain lines installed and connected properly
- Compressor, pump, cutter and other motor direction of rotation correct
- Make-up water float valve adjusted properly
- Hour meter in control panel connected

OPERATION CHECK

Machine charged with refrigerant lbs. _____ Actual voltage _____, _____ (machine running)
 Ambient temp. _____ °F Fan cycles On _____ Off _____ Tower water in _____ °F out _____ °F
 Comp motor RLA _____, _____, _____, Actual _____, _____, _____
 Pump RLA _____, _____, _____, Actual _____, _____, _____
 Cutter motor RLA _____, _____, _____, Actual _____, _____, _____
 Suction pressure end of freezing _____, end of harvest _____ Discharge pressure end of freezing _____, end of harvest _____
 Evaporator/suction line frost _____ Receiver liquid level operating _____

Test Cycle	Water Temp	Freeze Time Min/Sec	Harvest Time Min/Sec	First Ice Out Min/Sec	All Ice Out Min/Sec	Avg. Hole Size	Ice Lb. Per Harvest	Ice Lb. Per Day
#1								
#2								
#3								
#4								

Note: Ice lb. per day can be found by: $\frac{\text{ice lb. per harvest}}{\text{(freeze time + harvest time)}} \times 1440$

The machine operated satisfactorily for _____ continuous hours. Date _____

Comments _____

TABLE OF CONTENTS

Installer signature _____ End user signature _____
Please return to: **Tube-Ice Division, Henry Vogt Machine Co., P.O. Box 1918, Louisville, KY 40201**