



D E S I G N E D T O L E A D

FWZ Series

Oil-Fired Hot Water Boilers

INSTALLATION INSTRUCTIONS

These instructions must be affixed on or adjacent to the boiler



WARNING

Improper installation, adjustment, alteration, service or maintenance can cause property damage, injury, or loss of life. For assistance or additional information, consult a qualified installer, service agency or the gas supplier. This boiler requires a special venting system. Read these instructions carefully before installing.

Models:

- FWZ060
- FWZ080
- FWZ081
- FWZ100
- FWZ130
- FWZ160

Equipped with Hydrolevel
3250-Plus Control System



**Quality
Value &
Service**

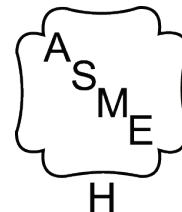

Crown Boiler Company
P.O. Box 14818
3633 I Street
Philadelphia, PA 19134
www.crownboiler.com

IMPORTANT INFORMATION - READ CAREFULLY

All boilers must be installed in accordance with National, State and Local Plumbing, Heating and Electrical Codes and the regulations of the serving utilities. These Codes and Regulations may differ from this instruction manual. Authorities having jurisdiction should be consulted before installations are made.

In all cases, reference should be made to the following Standards:

USA BOILERS

- A. Current Edition of American National Standard *ANSI/NFPA 31, "Installation of Oil Burning Equipment"*, for recommended installation practices.
- B. Current Edition of American National Standard *ANSI/NFPA 211, "Chimneys, Fireplaces, Vents, and Solid Fuel Burning Appliances"*, For Venting requirements.
- C. Current Edition of American Society of Mechanical Engineers *ASME CSD-1, "Controls and Safety Devices for Automatically Fired Boilers"*, for assembly and operations of controls and safety devices.
- D. All wiring on boilers installed in the USA shall be made in accordance with the National Electrical Code and/or Local Regulations.

CANADIAN BOILERS

- A. Current Edition of Canadian Standards Association *CSA B139, "Installation Code for Oil Burning Equipment"*, for recommended Installation Practices.
- B. All wiring on boilers installed in Canada shall be made in accordance with the Canadian Electrical Code and/or Local Regulations.

The following terms are used throughout this manual to bring attention to the presence of hazards of various risk levels, or to important information concerning product life.



DANGER

Indicates an imminently hazardous situation which, if not avoided, will result in death, serious injury or substantial property damage.



CAUTION

Indicates a potentially hazardous situation which, if not avoided, may result in moderate or minor injury or property damage.



WARNING

Indicates a potentially hazardous situation which, if not avoided, could result in death, serious injury or substantial property damage.

NOTICE

Indicates special instructions on installation, operation, or maintenance which are important but not related to personal injury hazards.



DANGER

This boiler is designed for use with #2 fuel oil meeting the specifications of ASTM D-396. Attempts to burn other liquid fuels, or to convert this boiler for use with gaseous fuels, could result in reliability problems, extensive property damage, or loss of life.

NOTICE

This boiler has a limited warranty, a copy of which is included with this boiler. The warranty for this boiler is valid only if the boiler has been installed, maintained and operated in accordance with these instructions.

Surface rust on cast iron sections may be attributed to the manufacturing process as well as condensation during storage. Surface rust is normal and does not affect the performance or longevity of a boiler.



DANGER

DO NOT store or use gasoline or other flammable vapors or liquids in the vicinity of this or any other appliance.



WARNING

Improper installation, adjustment, alteration, service or maintenance can cause property damage, personal injury or loss of life. Failure to follow all instructions in the proper order can cause personal injury or death. Read and understand all instructions, including all those contained in component manufacturers manuals which are provided with the boiler before installing, starting-up, operating, maintaining or servicing this boiler. Keep this manual and literature in legible condition and posted near boiler for reference by owner and service technician.

This boiler requires regular maintenance and service to operate safely. Follow the instructions contained in this manual.

Installation, maintenance, and service must be performed only by an experienced, skilled and knowledgeable installer or service agency.

All heating systems should be designed by competent contractors and only persons knowledgeable in the layout and installation of hydronic heating systems should attempt installation of any boiler.

Installation is not complete unless a pressure relief valve is installed as shown in Figure 8.1 located in Section VIII, "System Piping" of this manual.

It is the responsibility of the installing contractor to see that all controls are correctly installed and are operating properly when the installation is completed.

This boiler is suitable for installation on combustible flooring. Do not install boiler on carpeting.

Do not tamper with or alter the boiler or controls.

Inspect flueways at least once a year - preferably at the start of the heating season. The inside of the combustion chamber, the vent system and boiler flueways should be cleaned if soot or scale has accumulated.

When cleaning this boiler, take precaution to avoid damage to burner swing door insulation. If damaged, or if there is evidence of previous damage, burner swing door insulation must be replaced immediately.

Oil Burner and Controls must be checked at least once a year or as may be necessitated.

Do not operate boiler with jumpered or absent controls or safety devices.

Do not operate boiler if any control, switch, component, or device has been subject to water.

Boiler construction materials, products of combustion and the fuel contain alumina, silica, heavy metals, carbon monoxide, nitrogen oxides, aldehydes and/or other toxic or harmful substances which can cause death or serious injury and which are known to the state of California to cause cancer, birth defects and other reproductive harm. Always use proper safety clothing, respirators and equipment when servicing or working nearby the appliance.

This boiler contains very hot water under high pressure. Do not unscrew any pipe fittings nor attempt to disconnect any components of this boiler without positively assuring the water is cool and has no pressure. Always wear protective clothing and equipment when installing, starting up or servicing this boiler to prevent scald injuries. Do not rely on the pressure and temperature gauges to determine the temperature and pressure of the boiler. This boiler contains components which become very hot when the boiler is operating. Do not touch any components unless they are cool.



WARNINGS FOR THE HOMEOWNER

FOLLOW ALL INSTRUCTIONS and warnings printed in this manual and posted on the boiler.

INSPECT THE BOILER, BURNER AND CONTROLS ANNUALLY. To keep your boiler safe and efficient, have a service technician follow the Service checklist near the end of this manual.

IF YOU ARE NOT QUALIFIED to install or service boilers, do not install or service this one.

THE BOILER MAY LEAK WATER at the end of its useful life. Be sure to protect walls, carpets, and valuables from water that could leak from the boiler.

PROTECT YOUR HOME IN FREEZING WEATHER. A power outage, safety lockout, or component failure will prevent your boiler from lighting. In winter, your pipes may freeze and cause extensive property damage. Do not leave the heating system unattended during cold weather unless alarms

or other safeguards are in place to prevent such damage

DO NOT BLOCK AIR FLOW into or around the boiler. Insufficient air may cause the boiler to produce carbon monoxide or start a fire.

KEEP FLAMMABLE LIQUIDS AWAY from the boiler, including paint, solvents, and gasoline. The boiler may ignite the vapors from the liquids causing explosion or fire.

KEEP CHILDREN AND PETS away from hot surfaces of the boiler, boiler piping, and vent pipe.

CARBON MONOXIDE (CO) is an odorless, deadly gas that may be introduced into your home by any malfunctioning fuel-burning product or vent system failure. Consider installing CO alarms near bedrooms in all levels of the building to warn you and your family of potential CO exposure.



WARNINGS FOR THE INSTALLER

READ THIS ENTIRE MANUAL before attempting installation, start-up, or service. Improper installation, adjustment, alteration, service, or maintenance may cause serious property damage, personal injury, or death.

DO NOT DISCONNECT PIPE FITTINGS on the boiler or in the heating system without first verifying that the system is cool and free of pressure and that your clothing will protect you from a release of hot water or steam. Do not rely solely on the boiler's temperature and pressure gauge when making this judgment.

USE PROPER PERSONAL PROTECTION EQUIPMENT when servicing or working near the boiler. Materials of construction, flue products, and fuel contain alumina, silica, heavy metals, carbon monoxide, nitrogen oxides, and/or other toxic or harmful substances that can be hazardous to health and life and that are known to the State of California to cause cancer, birth defects, and other reproductive harm.

INSTALL ALL GUARDS, cover plates, and enclosures before operating the boiler.

SIZE THE BOILER PROPERLY relative to the design heat load or, if using domestic hot water priority, the peak hot water load, whichever is larger. A grossly oversized boiler will cycle excessively and this will lead to premature failure of the boiler and its components. Our warranty does not apply to damage from excessive cycling.

ADHERE TO ALL LOCAL CODE REQUIREMENTS. Contact your local code inspector prior to installation. In the absence of a local code, adhere to the latest editions of the *Installation of Oil Burning Equipment ANSI/NFPA 31* in the USA or *CAN/CSA B139, Installation Code for Oil Burning Equipment* in Canada.

ALL WIRING must comply with the *National Electrical Code ANSI/NFPA 70* (in the USA) or the *Canadian Electrical Code CSA C22.1* (in Canada) and any local regulations.



WARNING

This boiler must be properly vented. The chimney must be inspected for any obstructions and cleaned prior to each heating season. A clean and unobstructed chimney flue is necessary to produce the minimum draft required to safely evacuate noxious fumes that could cause personal injury or loss of life. Evidence of loose debris and or condensate induced stains at the base of the chimney flue, connector or smokepipe joints may be signs of condensing flue gases. Flue gas condensate is corrosive, which requires special consideration and must be addressed immediately. Refer to Section VII, "Venting" in this manual for more details.

This boiler needs fresh air for safe operation and must be installed so there are provisions for adequate combustion and ventilation air.

This boiler is supplied with controls which may cause the boiler to shut down and not re-start without service. If damage due to frozen pipes is a possibility, the heating system should not be left unattended in cold weather; or appropriate safeguards and alarms should be installed on the heating system to prevent damage if the boiler is inoperative.

This boiler is designed to burn No. 2 fuel oil only. Do not use gasoline, crankcase drainings, or any oil containing gasoline. Never burn garbage or paper in this boiler. Do not convert to any solid fuel (i.e. wood, coal). Do not convert to any gaseous fuel (i.e. natural gas, LP). All flammable debris, rags, paper, wood scraps, etc., should be kept clear of the boiler at all times. Keep the boiler area clean and free of fire hazards.

All boilers equipped with burner swing door have a potential hazard which, if ignored, can cause severe property damage, personal injury or loss of life. Before opening swing door, unplug burner power cord from receptacle located in lower right corner of jacket front panel and turn off service switch to boiler to prevent accidental firing of burner outside the combustion chamber. Be sure to tighten swing door fasteners completely when service is completed.

Table of Contents

I.	Product Description	5
II.	Specifications	5
III.	Before Installing	7
IV.	Field Assembly	8
V.	Locating the Boiler	11
VI.	Air for Combustion & Ventilation	12
VII.	Venting	16
VIII.	System Piping	19
IX.	Fuel Line Piping	24
X.	Wiring	27
XI.	Start-Up & Checkout	31
XII.	Operation	35
XIII.	Service & Maintenance	41
XIV.	Troubleshooting	44
XV.	Parts	49

I Product Description

The FWZ series boiler is a cast iron oil-fired water boiler designed for use in closed forced circulation heating systems. This boiler must be vented by natural draft into a lined masonry or metal chimney, or Type L vent. An adequate supply of air for combustion, ventilation and dilution of flue gases must be available in the boiler room.

II Specifications

TABLE 2.0: GENERAL SPECIFICATIONS

MODEL	DIMENSIONS			WATER CONTENT (GAL)	HEAT TRANSFER SURFACE AREA (SQ FT)	SHIPPING WEIGHT (LBS)
	'A'	'B'	'C'			
FWZ060	16-1/4"	24"	5"	7.70	13.29	430
FWZ080	16-1/4"	24"	5"	7.70	13.29	430
FWZ081	22-1/4"	24"	6"	11.08	20.29	545
FWZ100	22-1/4"	24"	6"	11.08	20.29	545
FWZ130	28-1/4"	30"	6"	14.46	27.29	658
FWZ160	34-1/4"	36"	7"	17.84	34.29	771

Maximum working pressure, Water - 50psi

TABLE 2.1: RATING DATA

 FWZ Series AHRI Ratings						Other Specifications		
MODEL*	BURNER INPUT		HEATING CAPACITY (MBH)	NET AHRI RATING* (MBH)	AFUE (%)	MINIMUM CHIMNEY REQUIREMENTS		
	GPH	MBH				ROUND IN. DIA.	SQUARE. TILE SIZE	HEIGHT FT.
FWZ060	0.60	84	73	63	86.0	6	8 X 8	15
FWZ080	0.80	112	97	84	86.3	6	8 X 8	15
FWZ081	0.80	112	99	86	87.0	6	8 X 8	15
FWZ100	1.00	140	123	107	87.0	6	8 X 8	15
FWZ130	1.30	182	160	139	87.0	7	8 X 8	15
FWZ160	1.60	222	197	171	87.0	7	8 X 8	15

Burner Capacity Rating, GPH is based on #2 fuel oil with a Gross Heating Value equal to 140,000 BTU/Gal.

* Net Ratings are based on piping and pick-up allowances of 1.15

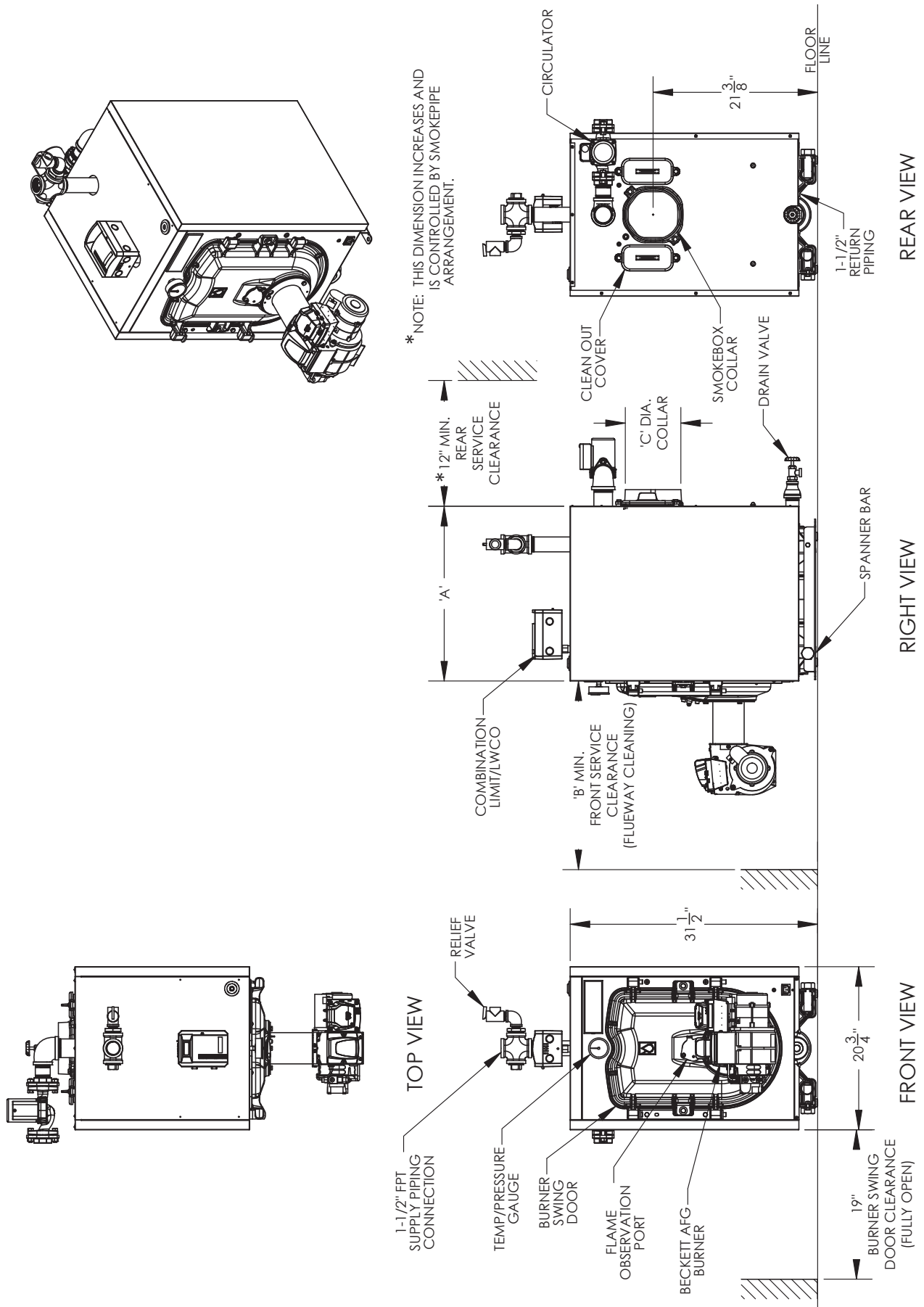

FIGURE 2.3: GENERAL CONFIGURATION *

* Circulator Supplied Loose - May Be Installed On Supply Or Return.

III Before Installing

- 1) Safe, reliable operation of this boiler depends upon installation by a professional heating contractor in strict accordance with this manual and the requirements of the authority having jurisdiction.
 - In the absence of an authority having jurisdiction, installation must be in accordance with this manual and the latest edition of *Installation of Oil Burning Equipment* (ANSI/NFPA31). Installations in Canada comply with the requirements of CSA B139-04 – *Installation Code for Oil-burning Equipment*.
 - Where required by the authority having jurisdiction, this installation must conform to the latest edition of *Standard for Controls and Safety Devices for Automatically Fired Boilers* (ANSI/ASME CSD-1).
- 2) Make sure that a properly sized chimney is available which is in good condition. Consult the authority having jurisdiction, Part VI of this manual, and ANSI/NFPA31 for additional information on venting requirements.
- 3) Make sure that the boiler is correctly sized:
 - For heating systems employing convection radiation (baseboard or radiators) use an industry accepted sizing method such as the *I=B=R* Guide RHH published by the Air-Conditioning, Heating and Refrigeration Institute (AHRI).
 - For new radiant heating systems refer to the radiant tubing manufacturer’s boiler sizing guidelines.
 - For systems including a Crown Mega-Stor indirect water heater, size the boiler to have either the Heating Capacity required for the Mega-Stor or the I=B=R Net Rating required for the heating system, whichever results in the larger boiler.
 - For systems that incorporate other indirect water heaters, refer to the indirect water heater manufacturer’s instructions for boiler output requirements.
- 4) In some cases, boilers installed at altitudes above 2000ft may require a different burner configuration from that at sea level. Consult the local Crown representative for more information.



CAUTION

As with all oil-fired appliances, “Power Venting” this boiler creates a number of potential problems, especially when this is done through a side wall. These include, but are not necessarily limited to:

- **Accelerated rate of soot buildup on the oil burner cad-cell, burner head, and/or in the boiler itself.**
- **Odor complaints**
- **Severe damage to the side of the structure in the event that the boiler operates at a high smoke level.**

These problems can occur for many reasons, some of which are out of the control of both the installer and the appliance manufacturer. The use of a chimney to vent this boiler is therefore recommended. If a power venter must be used, it is the responsibility of the installer and power venter manufacturer to “engineer” the power vent system. CROWN BOILER COMPANY WILL ASSUME NO RESPONSIBILITY FOR DAMAGE TO SIDING, ETC. FROM A POWER VENTED OIL-FIRED BOILER. THIS APPLIES REGARDLESS OF THE CAUSE OF THE SOOTING.



CAUTION

Fuel oil used with this boiler must conform to ASTM D396. The ASTM D396 standard sets a 5% limit on biodiesel concentration, requires that the biodiesel feedstock comply with ASTM D6751, and also specifies the procedure that must be used to blend the biodiesel feedstock with the #2 fuel oil. Attempts to use biodiesel blends not meeting all ASTM D396 requirements may result in unreliable operation or severe property damage.

IV Field Assembly

This boiler is shipped in two pieces:

- a) The crated boiler itself with the following loose parts either packed in the combustion chamber or glued to the skid:
 - Barometric Draft Regulator (if supplied)
 - Circulator (if supplied)
 - Relief valve
 - Pipe Fittings
- b) The burner carton consisting of the following items:
 - Oil Burner assembly
 - Baffles in some cases (see Table 4.1)
 - Refractory blanket in some cases (see Table 4.1)

It is recommended that the boiler be moved to its final location before the items in the burner carton are installed. To complete field assembly:



WARNING

Installation of burners on the FWZ other than those provided by Crown, and marked for use with this boiler, may result in unreliable operation, property damage, personal injury, or loss of life.

- 1) Make sure that the burner carton supplied is the correct one for the boiler. The crate tag on the boiler lists the Crown part numbers for the burner cartons that may be used with it.
- 2) Remove the burner mounting bolts and washers from the front door. Make sure that the burner gasket is in place and undamaged and mount the burner to the door.
- 3) Plug the burner cord into the receptacle on the lower right front corner of the boiler as shown in Figure 4.0
- 4) Install the barometric draft regulator, and other piping/trim, as described in the Venting and Piping sections of this manual.
- 5) Different baffle arrangements are used based on the boiler size and choice of burner. In some cases these baffles are included in the boiler and in other cases they are provided in the burner carton. In addition, some models use a refractory blanket which is shipped in the burner carton and which must be installed in the combustion chamber. Finally, in some cases burners are supplied with insulation wrapped around the inserted burner tube. Table 4.3 summarizes the use of baffles, blankets, and burner tube insulation.
- 6) Attach the model-specific rating plate for the specific boiler model that is provided in the burner box to the left of the permanent rating plate already on the boiler (Figure 4.0). Note that some burner boxes may contain rating plates for both water and steam models; be sure to select the appropriate FWZ series rating plate. Before applying the rating plate clean the area where it is to be applied with a clean, dry lint free cloth.

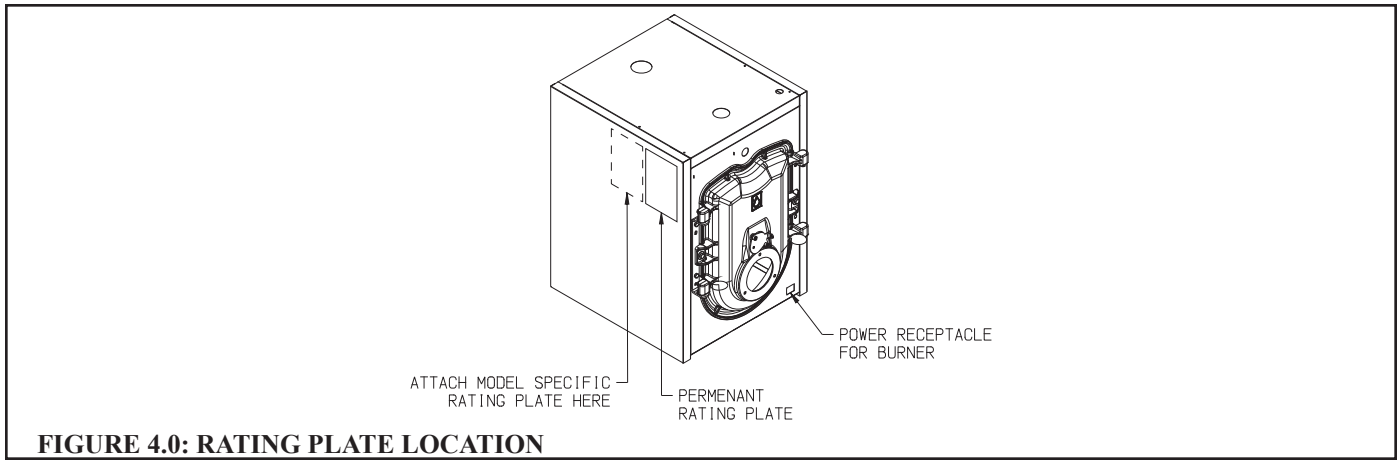

FIGURE 4.0: RATING PLATE LOCATION

TABLE 4.1: BASIC BOILER CONFIGURATIONS

Model	Boiler Part No.	Burner	Burner Carton Part #	Blanket	Burner Tube Insulation	2nd Pass Baffle (410009)	2nd Pass Baffle (410008)	3rd Pass Baffle (410007)
FWZ060	FWZ002 ¹	Beckett ²	41060B	No	No	No	No	Yes
FWZ080	FWZ002 ¹	Beckett ²	41080B	No	No	Yes ³	No	Yes
FWZ081	FWZ003 ¹	Beckett	41081B	Yes ³	No	No	No	Yes ³
FWZ081	FWZ003 ¹	Riello	41081R	Yes ³	Yes	No	No	Yes ³
FWZ081	FWZ003 ¹	Carlin	41081C	Yes ³	Yes	No	No	Yes ³
FWZ100	FWZ003 ¹	Beckett	41100B	No	No	No	Yes ³	No
FWZ100	FWZ003 ¹	Riello	41100R	No	No	No	Yes ³	No
FWZ100	FWZ003 ¹	Carlin	41100C	Yes ³	Yes	No	Yes ³	Yes ³
FWZ130	FWZ004 ¹	Beckett	41130B	No	No	No	Yes	No
FWZ130	FWZ004 ¹	Riello	41130R	No	No	No	Yes	No
FWZ130	FWZ004 ¹	Carlin	41130C	Yes ³	Yes	No	Yes	Yes ³
FWZ160	FWZ005 ¹	Beckett	41160B	No	No	No	Yes	No
FWZ160	FWZ005 ¹	Riello	41160R	No	No	No	Yes	No
FWZ160	FWZ005 ¹	Carlin	41160C	Yes ³	Yes	No	Yes	Yes ³

1 Boiler PN may contain additional characters after those shown to designate other options

2 FWZ060 and FWZ080 not available with Carlin or Riello Burner.

3 Included in burner box.

Figure 4.2 identifies the type and location of baffles. When used, lay the refractory blanket in the combustion chamber with the 19-1/2" side oriented as shown in Figure 4.2. Line the front edge of the blanket up with the edge of the combustion chamber. The blanket should run the entire length of the chamber. No adhesive is required to hold the blanket in place.

When required, burner tube insulation is applied at the factory and secured in place with masking tape. This tape is only needed to hold the insulation in place while the burner is being installed through the door. After installation, the tape will harmlessly burn away and the insulation will be secured by the door refractory.



WARNING

- Do not omit the blanket when called for in the table above.
- Do not add any extra baffles beyond those prescribed for the model/burner combination shown in Table 4.1.

Doing either of these things could cause accelerated chimney deterioration due to condensation or inadequate draft resulting in severe property damage, personal injury or death.

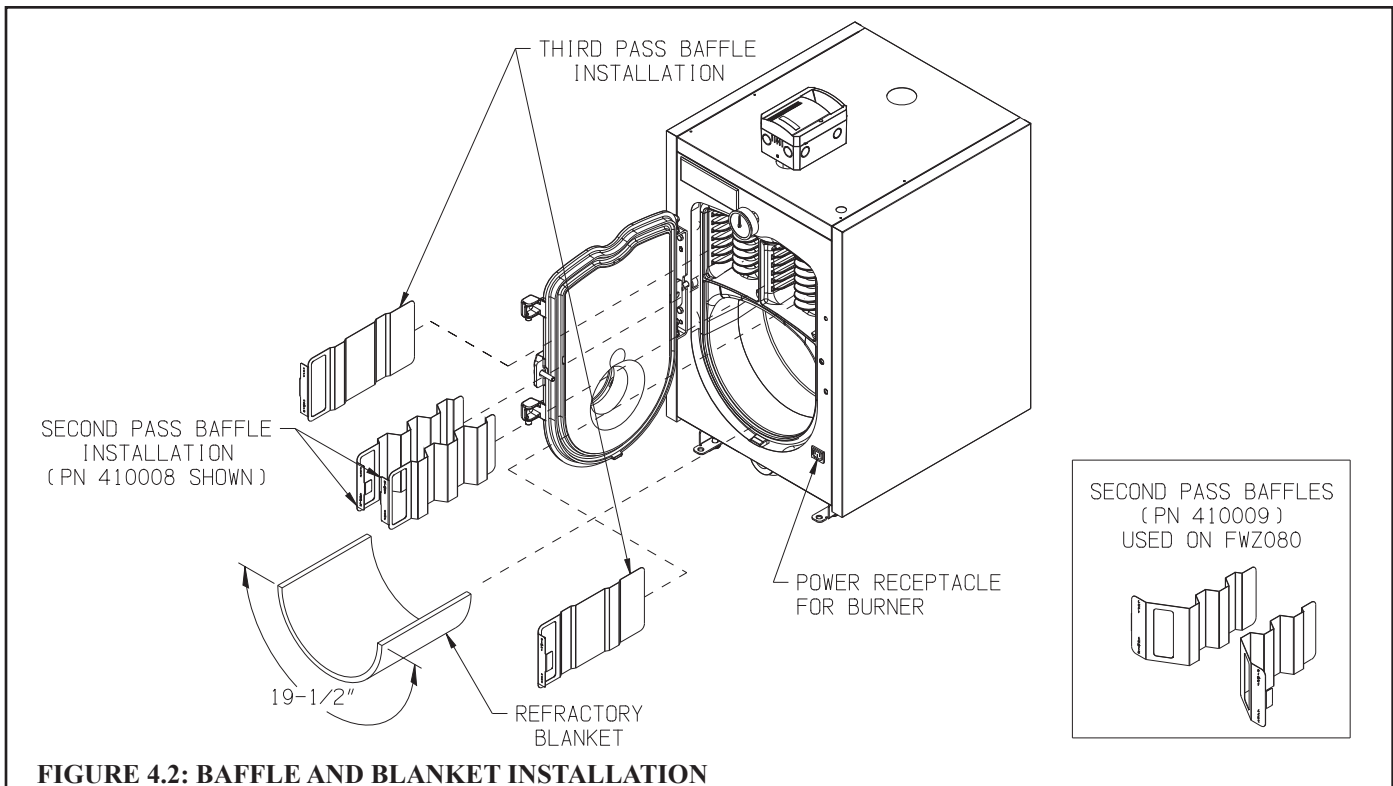

FIGURE 4.2: BAFFLE AND BLANKET INSTALLATION

V Locating the Boiler



WARNING

Failure to observe the following location requirements could result in property damage, a fire, explosion or carbon monoxide (CO) hazard.

1) Clearances:

- Observe the minimum clearances shown below. Except as noted, these clearances apply to all combustible construction, as well as noncombustible walls, ceilings and doors. Also see Figure 5.0.

Front - 24" (from front Jacket surface)

Left Side - 6"

Right Side - 6"

Rear - 12"

Top - 6"

Single Wall Chimney Connector (to combustible construction) - 18"

- A 24" service clearance is recommended above the top of the boiler, as well as on the side to which the burner swing door opens (the left side as the boiler is shipped). See also dimension 'B' in Table 2.0 for recommended service clearances to the front of the boiler. These clearances may be reduced to those shown above; however, servicing the boiler will become increasingly difficult as these clearances are reduced.

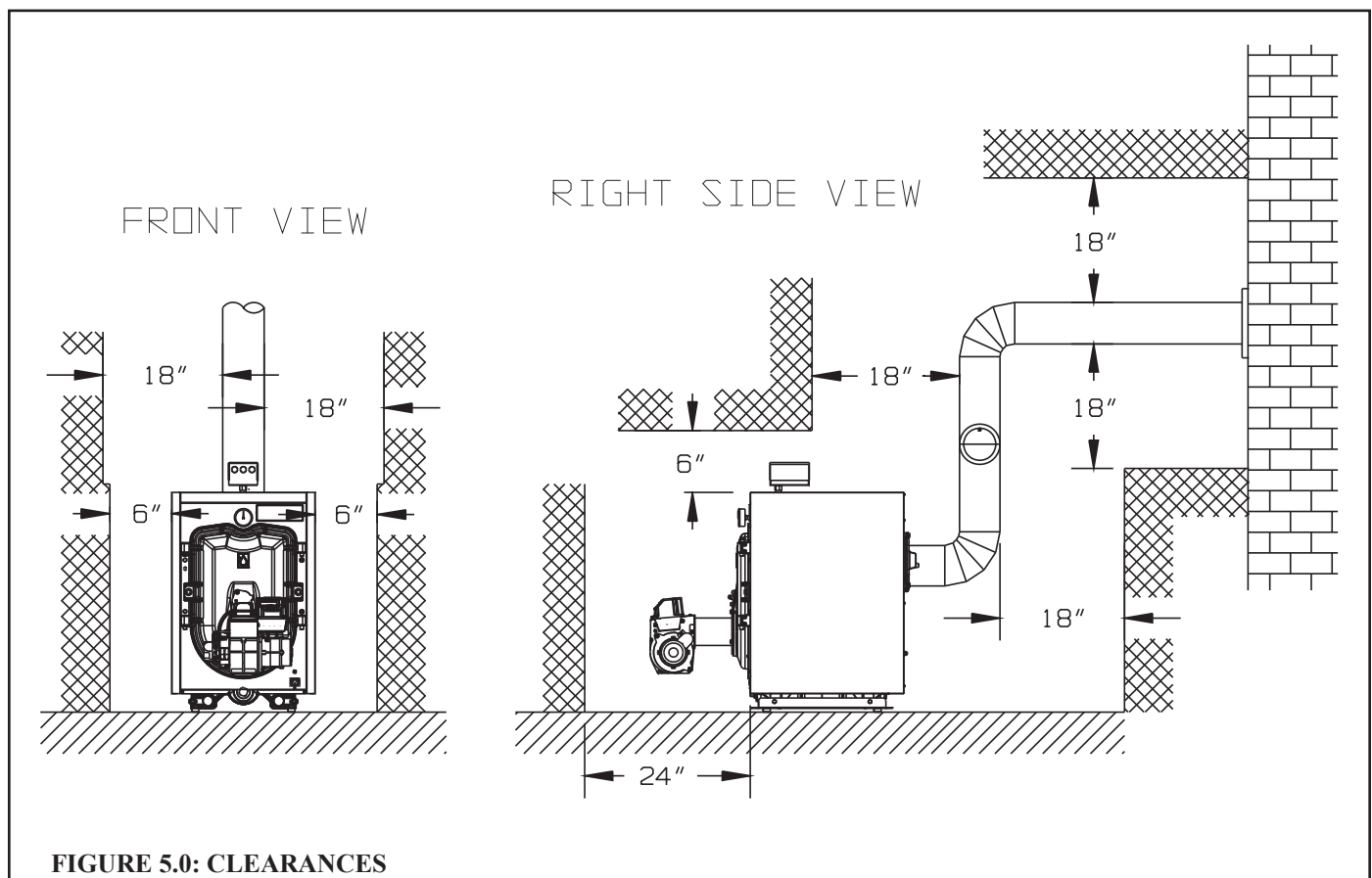
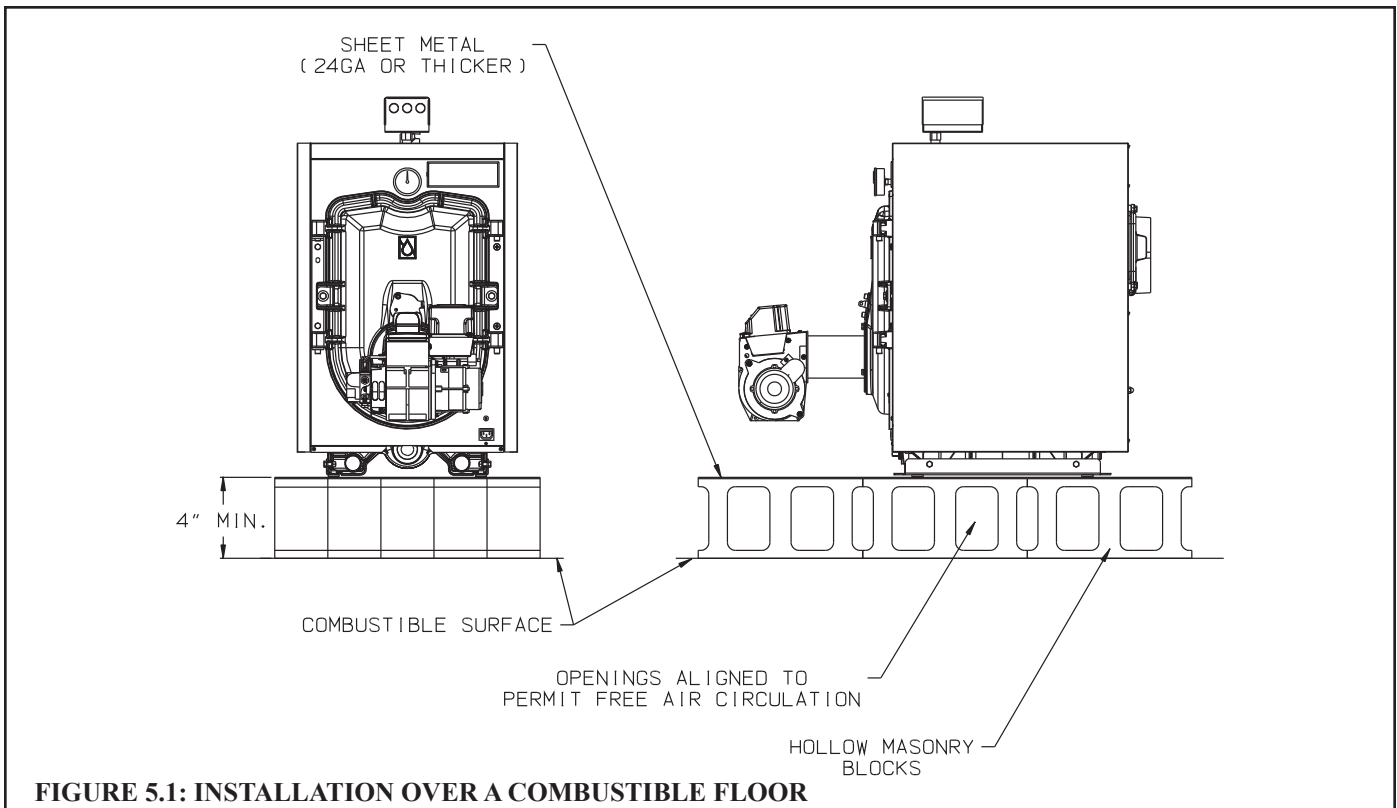

FIGURE 5.0: CLEARANCES

- 1) Do not install this boiler directly on a combustible floor. Where it is desired to install an FWZ on a non-carpeted combustible floor, install the boiler on a base constructed as shown in Figure 5.1
- 2) If listed Type L vent is used, follow vent pipe manufacturer recommendations for minimum clearances.
- 3) Do not install this boiler in a location where gasoline or other flammable vapors or liquids will be stored or used. Do not install this boiler in an area where large amounts of airborne dust will be present, such as a workshop.



VI Air for Combustion and Ventilation

Sufficient fresh air must be supplied for combustion and ventilation. Provisions for combustion and ventilation air for oil burning equipment must be made in accordance with the *Standard for the Installation of Oil Burning Equipment (ANSI/NFPA 31)*.

To ensure an adequate supply of air for combustion, ventilation and flue gas dilution, start by determining whether adequate combustion and ventilation air can be obtained through natural infiltration (air leaking into the building through cracks around windows, doors, etc). Examples of construction features which could prevent adequate natural infiltration include:

- Walls and ceilings exposed to outside atmosphere having a continuous water vapor retarder with a rating of 1 perm or less with openings gasketed and sealed
- Weather stripping added on openable windows and doors
- Caulking and sealants are applied to areas such as joints around window and door frames, between sole plates and floors, between wall-ceiling joints, between wall panels, at penetrations for plumbing, electrical, and gas lines, and at other openings.
- Large exhaust fans

In this manual, buildings where natural infiltration will not provide adequate air for combustion, and ventilation are referred to as “buildings of unusually tight construction”. If in doubt, assume that the building in which the boiler is installed is of unusually tight construction.

A. For Buildings of Other than Unusually Tight Construction

- 1) Determine whether the boiler is to be installed in a confined space - A confined space is defined as having a volume less than 50 cubic feet per 1000 BTU/hr input of all appliances installed in that space. To determine whether the boiler room is a confined space:
 - a) Total the input of all appliances in the boiler room in thousands of BTU/hr. Round the result to the next highest 1000 BTU/hr.
 - b) Find the volume of the room in cubic feet. The volume of the room in cubic feet is:
Length (ft) x width (ft) x ceiling height (ft)
In calculating the volume of the boiler room, consider the volume of adjoining spaces only if no doors are installed between them. If doors are installed between the boiler room and an adjoining space, do not consider the volume of the adjoining space, even if the door is normally left open.
 - c) Divide the volume of the boiler room by the input in thousands of BTU/hr. If the result is less than 50, the boiler room is a confined space.

Example:

An FWZ080 and a water heater are to be installed in a room measuring 6 ft - 3 in x 7 ft with an 8 ft ceiling. The water heater has an input of 30000 BTU/hr:

Input of FWZ080 = 0.80 Gal/hr x 140000 BTU/Gal = 112000 BTU/hr

Total input in thousands of BTU/hr = (112000 BTU/hr + 30000 BTU/hr)/1000 = 142

Volume of room = 6.25 ft x 7 ft x 8 ft = 350 ft³

350/142 = 2.46. Since 2.46 is less than 50, the boiler room is a confined space.

- 2) Unconfined Space - Natural infiltration into the boiler room will normally provide adequate air for combustion and ventilation without additional louvers or openings into boiler room.
- 3) Confined Space - Provide two openings into the boiler room, one near the floor and one near the ceiling. The top edge of the upper opening must be within 12" of the ceiling and the bottom edge of the lower opening must be within 12" of the floor (Figure 6.0).
 - Each opening must have a free area of 1 square inch per 1000 BTU/hr input of all fuel burning appliances in the boiler room. The minimum opening dimension is 3 inches. Minimum opening free area is 100 square inches per opening.
 - If the total volume of both the boiler room and the room to which the openings connect is less than 50 cubic feet per 1000 BTU/hr of total appliance input, install a pair of identical openings into a third room. Connect additional rooms with openings until the total volume of all rooms is at least 50 cubic feet per 1000 BTU/hr of input.
 - The "free area" of an opening takes into account the blocking effect of mesh, grills, and louvers. Where screens are used, they must be no finer than ¼" (4 x 4) mesh.

B. For Buildings of Unusually Tight Construction

- 1) Openings must be installed between the boiler room and the outdoors or a ventilated space, such as an attic or crawl space, which communicates directly with the outdoors.
- 2) Two openings are required. The top edge of the upper opening must be within 12 inches of the ceiling. The bottom edge of the lower opening must be within 12 inches of the floor.
- 3) Size openings and ducts as follows:
 - Vertical ducts or openings directly outdoors (Figure 6.1, Figure 6.2, and Figure 6.3) - Each opening must have a free cross sectional area of 1 square inch per 4000 BTU/hr of the total input of all fuel fired appliances in the boiler room but not less than 100 square inches. Minimum opening size is 3 inches.
 - Openings to outdoors via horizontal ducts (Figure 6.4) - Each opening must have a free cross sectional area of 1 square inch per 2000 BTU/hr of the total input of all fuel fired appliances in the boiler room but not less than 100 square inches. Minimum opening size is 3 inches.
 - The "free area" of an opening takes into account the blocking effect of mesh, grills, and louvers. Where screens are used, they must be no finer than ¼" (4 x 4) mesh.

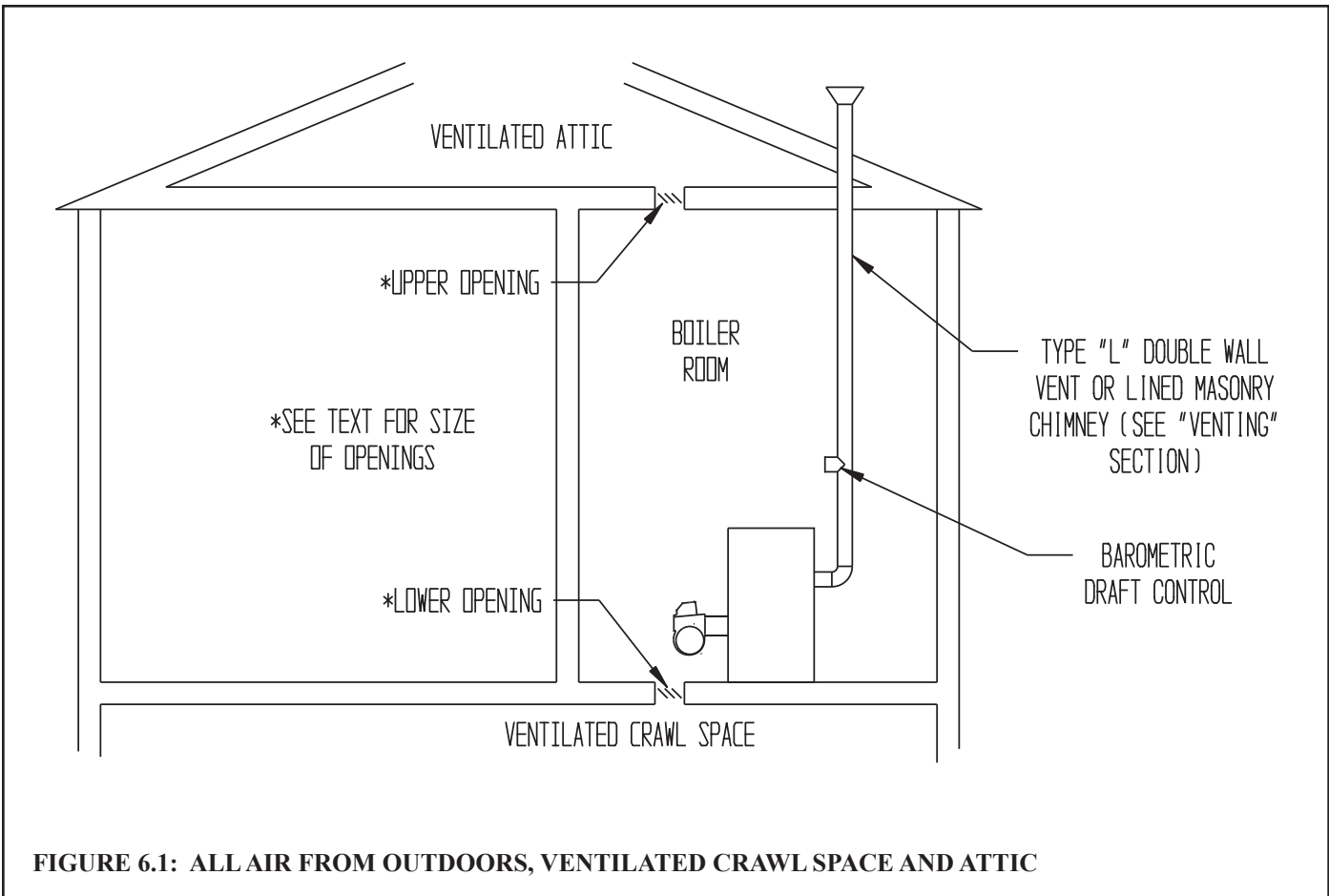
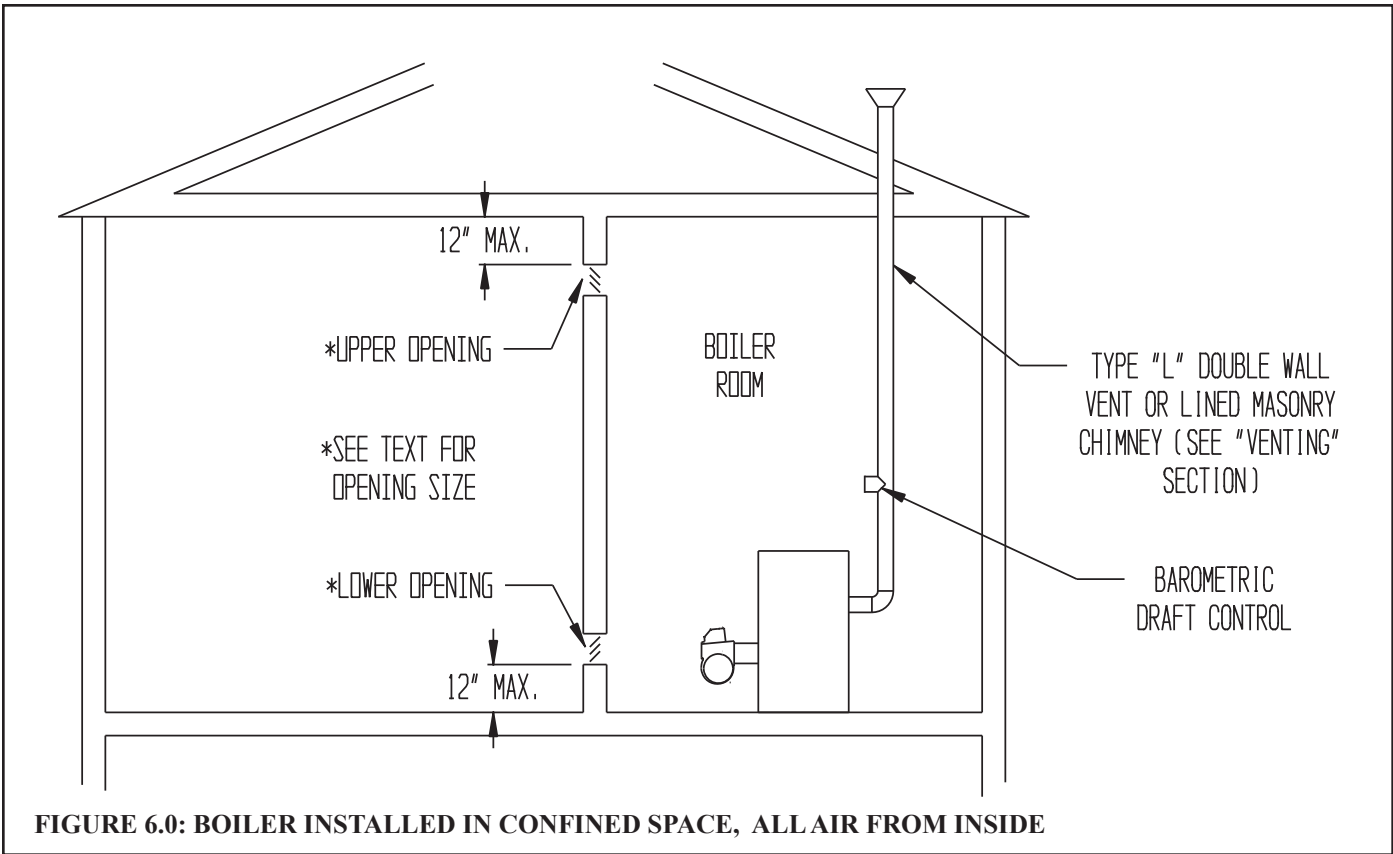

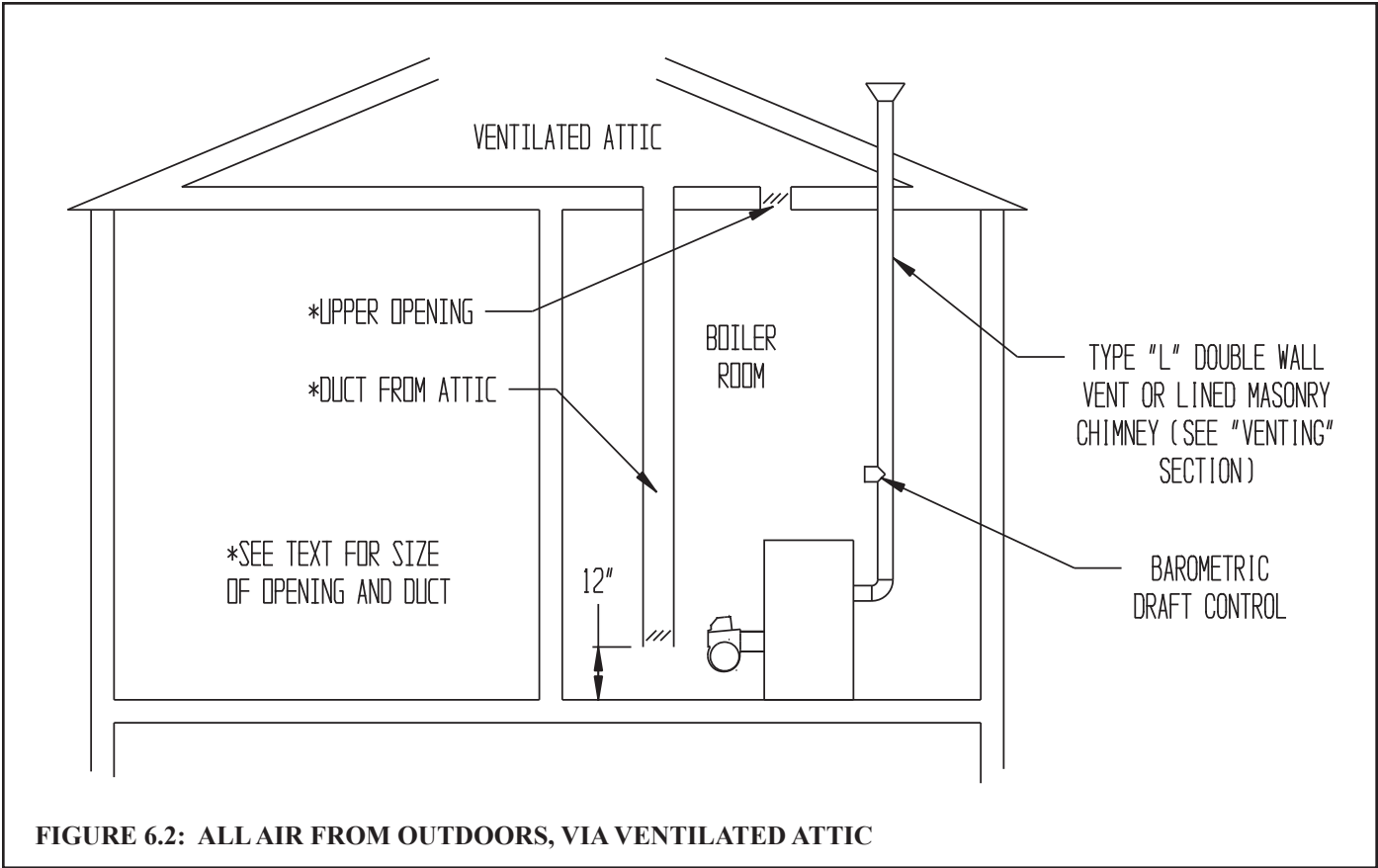

FIGURE 6.2: ALL AIR FROM OUTDOORS, VIA VENTILATED ATTIC

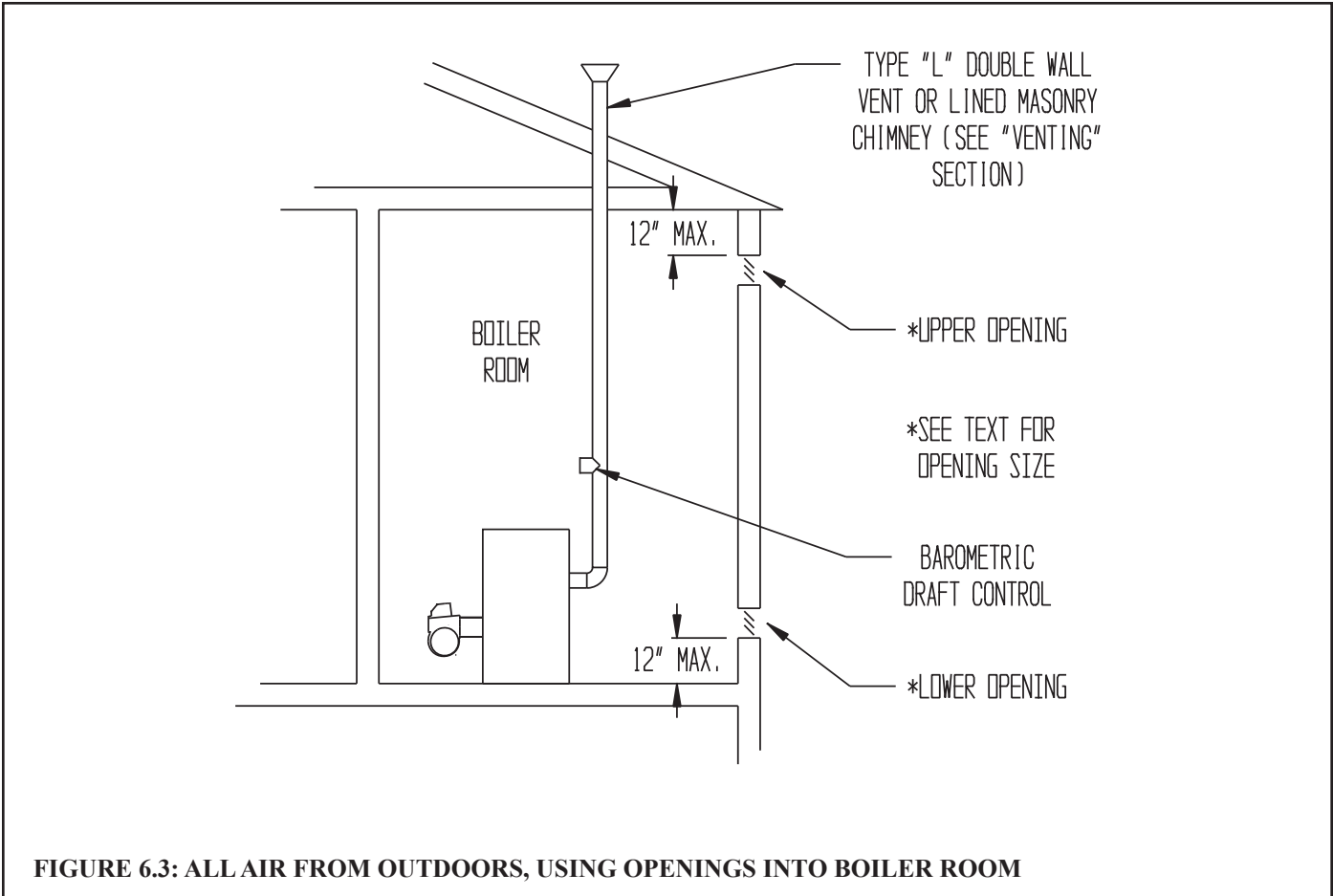

FIGURE 6.3: ALL AIR FROM OUTDOORS, USING OPENINGS INTO BOILER ROOM

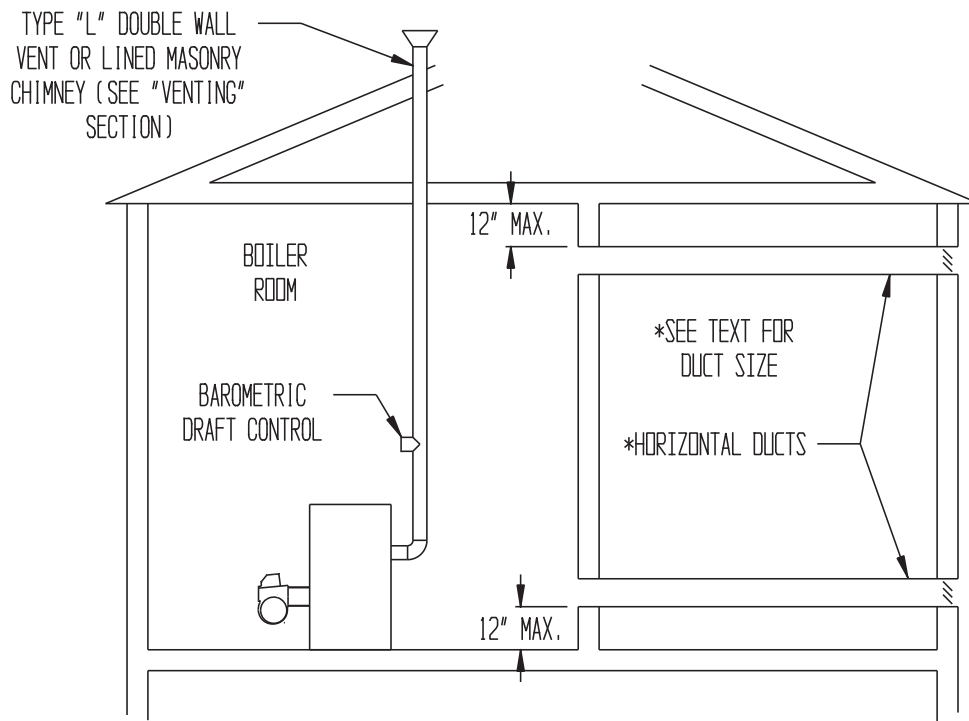

FIGURE 6.4: ALL AIR FROM OUTDOORS, USING HORIZONTAL DUCTS INTO BOILER ROOM

VII Venting

WARNING

- Improper venting may result in property damage and/or the release of flue gases, which contain deadly carbon monoxide (CO), into the home, which can cause severe personal injury or death.
- Inspect existing chimney before installing boiler. Failure to clean or replace damaged pipe or tile lining will cause property damage, severe personal injury or death.
- Do not de-rate the appliance. Failure to fire the unit at its designed input may cause excessive condensation upon the interior walls of the chimney. In addition, the lower input may not create enough draft to adequately evacuate the products of combustion.
- Do not omit the blanket when called for in the table above.
- Do not add any extra baffles beyond those prescribed for the model/burner combination shown in Table 4.1.

Doing either of these things could cause accelerated chimney deterioration due to condensation or inadequate draft resulting in severe property damage, personal injury or death.

The vent installation must be in accordance with local building codes, or the local authority having jurisdiction. Contact your local fire and building officials on specific requirements for restrictions and the installation of fuel oil burning equipment. In the absence of other applicable codes, the vent system installation must meet the requirements of NFPA 31 – *Standard for the Installation of Oil-Burning Equipment* and NFPA 211 - *Standard for Chimneys, Fireplaces, Vents, and Solid Fuel-Burning Appliances*. Vent systems in Canada must comply with CSA B139-04 – *Installation Code for Oil-burning Equipment*.

A typical vent system is illustrated in Figure 7.0. The components of the vent installation are the vent connector (breeching), barometric draft regulator, and chimney.

- 1) Acceptable Chimneys - The following chimneys may be used to vent a FWZ series boiler:
 - Listed Type L vent - Install in accordance with the manufacturer’s instructions, the terms of its listing, and applicable codes.
 - Masonry Chimney - The masonry chimney must be constructed in accordance with the latest edition of *Standard for Chimneys, Fireplaces, Vents, and Solid Fuel Burning Appliances* (NFPA 211) and lined with a clay liner or other listed lining system. Do not vent a FWZ series boiler into an unlined chimney.
- 2) Acceptable Vent Connectors - The following may be used for vent connectors:
 - Listed Type L vent.
 - Single Wall Galvanized Pipe - Use 0.018” (26 gauge) or heavier.
- 3) Chimney and Vent Connector Sizing - See Table 7.1 for minimum vent connector and chimney sizing. The vent connector size must not be smaller than boiler flue collar diameter.
- 4) Do not vent this appliance into any portion of a mechanical vent system operating under positive pressure.
- 5) Do not connect the boiler into a chimney flue serving an open fireplace or other solid fuel appliance.
- 6) Prior to boiler installation, an existing chimney must be inspected by a qualified person in accordance with the requirements of Chapter 11 of NFPA 211, *Standard for Chimneys, Fireplaces, Vents, and Solid Fuel-Burning Appliances*. This inspection is intended to identify safety problems with the chimney such as obstructions, a missing or damaged liner, or leak points. Clean chimney as necessary and correct any other chimney defects before installing the boiler.
- 7) Vent connector must slope upward from boiler not less than one inch in four feet. No portion of vent pipe should run downward or have sags. Vent connector must be securely supported.
- 8) The vertical section of vent connector coming off the boiler should be as tall as possible, while still maintaining the proper clearance from the horizontal vent connector to combustibles and the proper pitch called for in (7) above.
- 9) Vent connector must be installed above the bottom of the chimney to minimize risk of blockage.
- 10) Vent connector must be inserted flush with inside face of the chimney liner and the space between vent connector and chimney sealed tight. A thimble permanently cemented in place can be used to facilitate removal of vent connector for cleaning.
- 11) Install the barometric draft regulator supplied with this boiler in accordance with the regulator manufacturer’s instructions. No other draft regulator shall be used. Mount the barometric draft regulator in the side connection of a tee (not supplied).
- 12) Secure all joints in the vent connector system with sheet metal screws. This includes the joint between the vent connector and the boiler collar (see Figure 7.0, Detail ‘A’), as well as the barometric draft regulator. Use at least three screws at each joint.

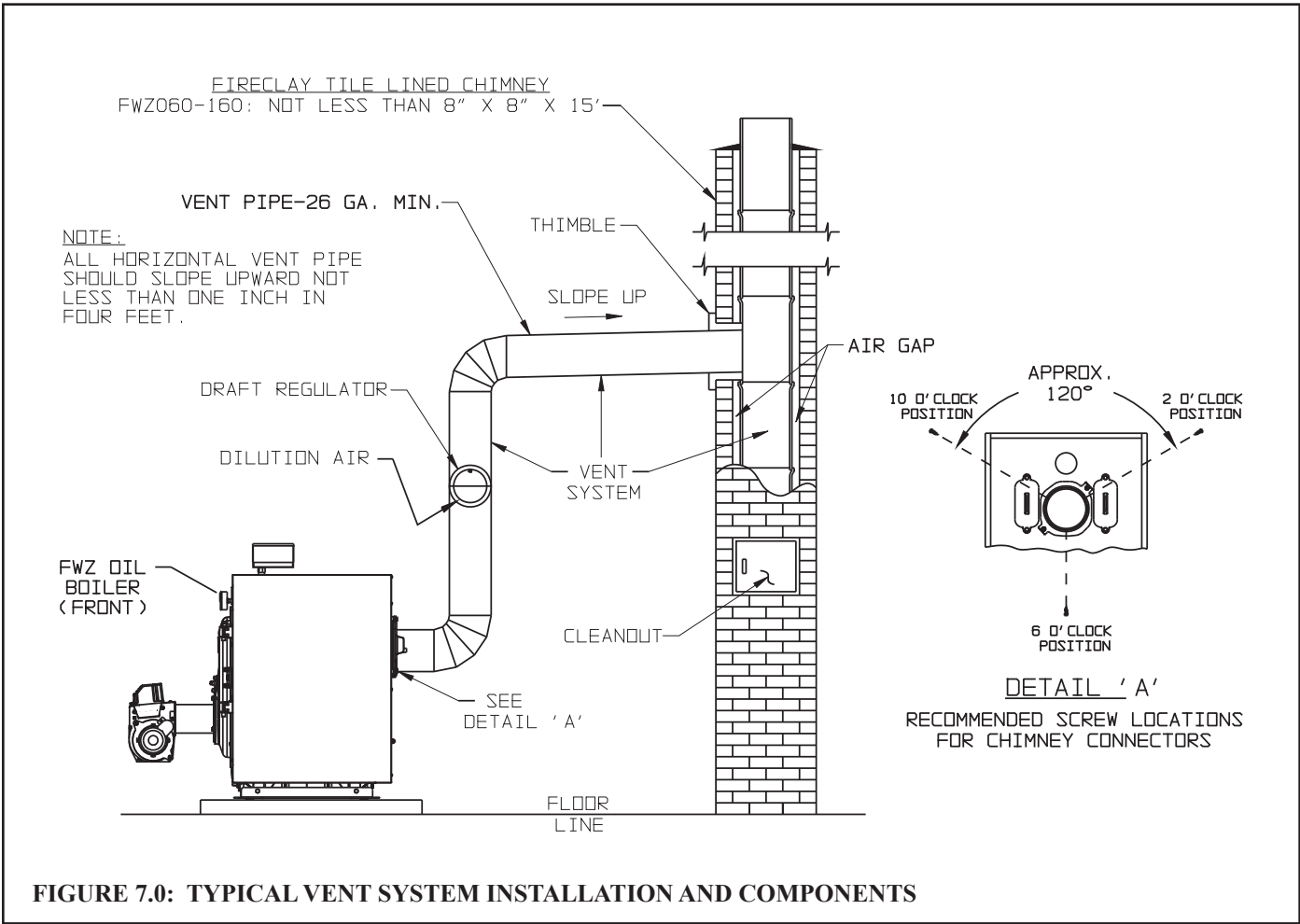

TABLE 7.1: MINIMUM RECOMMENDED BREECHING AND CHIMNEY SIZE

BOILER MODEL	MINIMUM BREECHING DIA. (INCHES)	MINIMUM CHIMNEY REQUIREMENTS		
		ROUND I.D. (IN.)	SQUARE. TILE SIZE (NOMINAL)	HEIGHT (FT.)
FWZ060	5	6	8 X 8	15
FWZ080	5	6	8 X 8	15
FWZ081	5	6	8 X 8	15
FWZ100	6	6	8 X 8	15
FWZ130	6	7	8 X 8	15
FWZ160	7	7	8 X 8	15

VIII System Piping



WARNING

- **Install boiler so that the electrical components are protected from water (dripping, spraying, rain, etc.) During appliance operation and service (circulator replacement, etc.).**
- **Operation of this boiler with continuous return temperatures below 135°F can cause severe boiler or chimney damage.**
- **Do not operate this boiler at a flow rate less than the minimum shown in Table 8.0, Column (a).**
- **Operation of this boiler in a system having significant amounts of dissolved oxygen can cause severe heat exchanger corrosion damage.**
- **Do not use toxic additives, such as automotive antifreeze, in a hydronic system.**
- **Pipe relief valve discharge to a safe location. The relief valve may discharge scalding hot water.**
- **Do not install a valve in the relief valve discharge line.**
- **Do not move relief valve from factory location.**
- **Do not plug relief valve discharge. Blocking the relief valve may result in boiler explosion.**

A. Standard Piping

Figure 8.2 shows typical boiler system connections on a single zone system. Additional information on hydronic system design may be found in the *I=B=R* Guide RHH published by the Air-Conditioning, Heating and Refrigeration Institute (AHRI). The components in this system and their purposes are as follows:

- 1) **Relief valve (Required)** - Mount the relief valve on the rear of the boiler as shown in Figure 8.1 using the fittings provided. The relief valve shipped with the boiler is set to open at 30 psi. This valve may be replaced with one having a pressure up to the “Maximum Allowable Working Pressure” shown on the rating plate. If the valve is replaced, the replacement must have a relief capacity in excess of the heating capacity for the boiler.

Pipe the discharge of the relief valve to a location where water or steam will not create a hazard or cause property damage if the valve opens. The end of the discharge pipe must terminate in an unthreaded pipe. If the relief valve discharge is not piped to a drain, it must terminate at least 6 inches above the floor. Do not run relief valve discharge piping through an area that is prone to freezing. The termination of the relief valve discharge piping must be in an area where it is not likely to become plugged by debris.
- 2) **Return Injector Pipe** - The return injector distributes water evenly throughout the heat exchanger and also helps to minimize the possibility of thermal shock. Install it in the upper-rear tapping as shown in Figure 8.1. The 2 x 1-1/2” reducing elbow can be oriented in any direction.
- 3) **Circulator (Required)** - Figure 8.2 shows the ideal location of the circulator which is in the supply piping immediately downstream of the expansion tank. A less ideal, but acceptable, location for most residential circulators is in the return. The circulator/s and connected piping should be sized so that the temperature rise across the boiler is 20F. Burner operation while the flow through the boiler is less than that shown in Table 8.0, column (a) could result in problems regulating the supply temperature. If the system is zoned, the flow rate through the boiler should be greater than that shown in Table 8.0 when only the zone having the lowest flow rate is on. If this requirement cannot otherwise be met, use a bypass, or primary-secondary piping. Boiler head loss data at the minimum flow and the flow corresponding to a 20F rise are shown in Table 8.0.
- 4) **Expansion Tank (Required)** - If this boiler is replacing an existing boiler with no other changes in the system, the old expansion tank can generally be reused. If the expansion tank must be replaced, consult the expansion tank manufacturer’s literature for proper sizing.

- 5) Fill Valve (Required) - Either a manual or automatic fill valve may be used. The ideal location for the fill is at the expansion tank.
- 6) Automatic Air Vent (Required) - At least one automatic air vent is required. Manual vents will usually be required in other parts of the system to remove air during initial fill.
- 7) Low Water Cut-Off (Required in some situations) - A low water cut-off is required when the boiler is installed above radiation. In addition, some codes such as ASME CSD-1, require low water cut-offs. Codes may also require that this low water cut-off have a manual reset function. The low water cut-off may be a float type or probe type, but must be designed for use in a hot-water system. The low water cut-off should be piped into the boiler supply just above the boiler with no intervening valves between it and the boiler. Use a low water cut-off that breaks the 120 VAC supply to the boiler. Do not attempt to wire a 24-volt low water cut-off into the boiler factory wiring.
- 8) Manual Reset High Limit (Required by some codes) - This control is required by ASME CSD-1 and some other codes. Install the high limit in the boiler supply piping just beyond the boiler with no intervening valves. Set the manual reset high limit as far above the operating limit setting as possible, but not over 240°F. Wire the control to break the 120 VAC electrical supply to the boiler.
- 9) Flow Control Valve (Required under some conditions) - The flow control valve prevents flow through the system unless the circulator is operating. A flow control valve may be necessary on converted gravity systems to prevent gravity circulation. Flow control valves are also used to prevent “ghost flows” in circulator zone systems through zones that are not calling for heat.
- 10) Isolation Valves (Optional) - Isolation valves are useful if the boiler must be drained, as they will eliminate having to drain and refill the entire system.
- 11) Drain Valve - The drain valve is shipped in the boiler parts bag. Install it in the bottom-rear of the boiler return as shown in Figure 8.1.

Table 8.0 Minimum Flow Rate Requirements

Model	Minimum Flow (Approx 35F Rise)*		Flow at 20F Rise	
	(a)	(c)	(d)	(e)
	Min. Flow (Gal /Min)	Boiler Head Loss (ft w.c.)	Flow (GPM)	Boiler Head Loss (ft w.c.)
FWZ060	4.5	0.10	7.3	0.22
FWZ080	6.0	0.16	9.7	0.38
FWZ081	8.0	0.27	9.9	0.40
FWZ100	8.0	0.27	12.3	0.61
FWZ130	10.0	0.42	16.0	0.88
FWZ160	12.0	0.61	19.7	1.45

* Approximate 25°F Rise for FWZ081

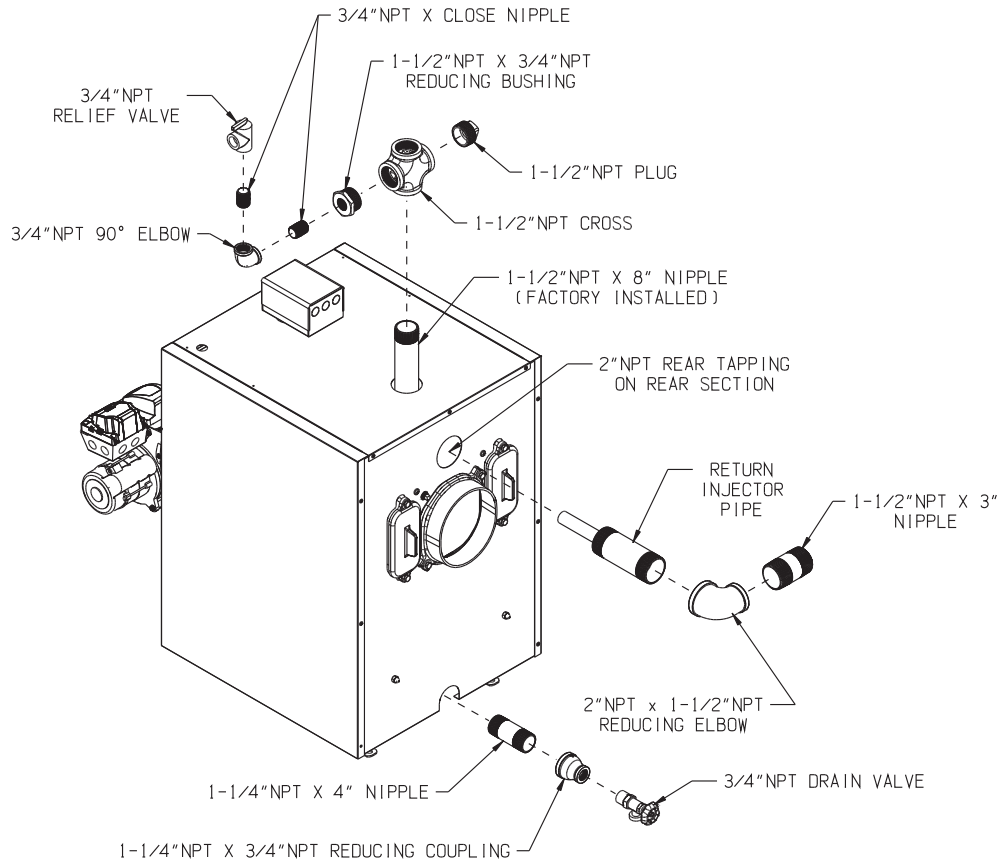

FIGURE 8.1: INSTALLATION OF FACTORY SUPPLIED PIPING

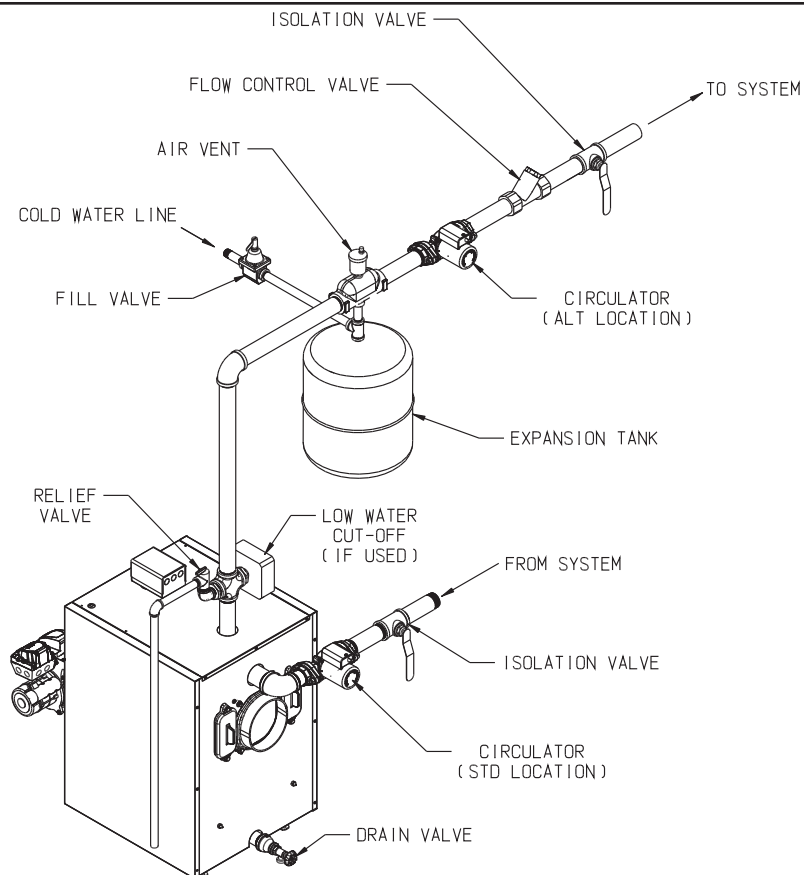

FIGURE 8.2: STANDARD BOILER PIPING

B. Piping for Special Situations

Certain types of heating systems have additional requirements. Some of the more common variations follow:

- 1) Indirect Water Heaters - Figure 8.3 shows typical indirect water heater piping. Boiler piping is the same as for any two zone system. Figure 8.3 shows circulator zoning, which is usually preferred for indirect water heaters. Size the circulator and indirect water heater piping to obtain the boiler water flow through the indirect water heater called for by the indirect water heater manufacturer.
- 2) Large Water Volume Systems - The piping shown in Figure 8.4 will minimize the amount of time that the boiler operates with return temperatures below 135°F on these systems. A bypass is installed as shown to divert some supply water directly into the return water. The bypass pipe should be the same size as the supply. The two throttling valves shown are adjusted so that the return temperature rises above 135°F during the first few minutes of operation. A three-way valve can be substituted for the two throttling valves shown. A bypass can also be used to ensure that the minimum flow requirement in Table 8.0 is met.
- 3) Systems Containing Oxygen - Many hydronic systems contain enough dissolved oxygen to cause severe corrosion damage to a cast iron boiler such as the FWZ. Some examples include:
 - Radiant systems that employ tubing without an oxygen barrier.
 - Systems with routine additions of fresh water.
 - Systems which are open to the atmosphere.

If the boiler is to be used in such a system, it must be separated from the oxygenated water being heated with a heat exchanger as shown in Figure 8.5. Consult the heat exchanger manufacturer for proper heat exchanger sizing as well as flow and temperature requirements. All components on the oxygenated side of the heat exchanger, such as the pump and expansion tank, must be designed for use in oxygenated water.

- 4) Air Handlers - Where the boiler is connected to air handlers through which refrigerated air passes, use flow control valves in the boiler piping or other automatic means to prevent gravity circulation during the cooling cycle.

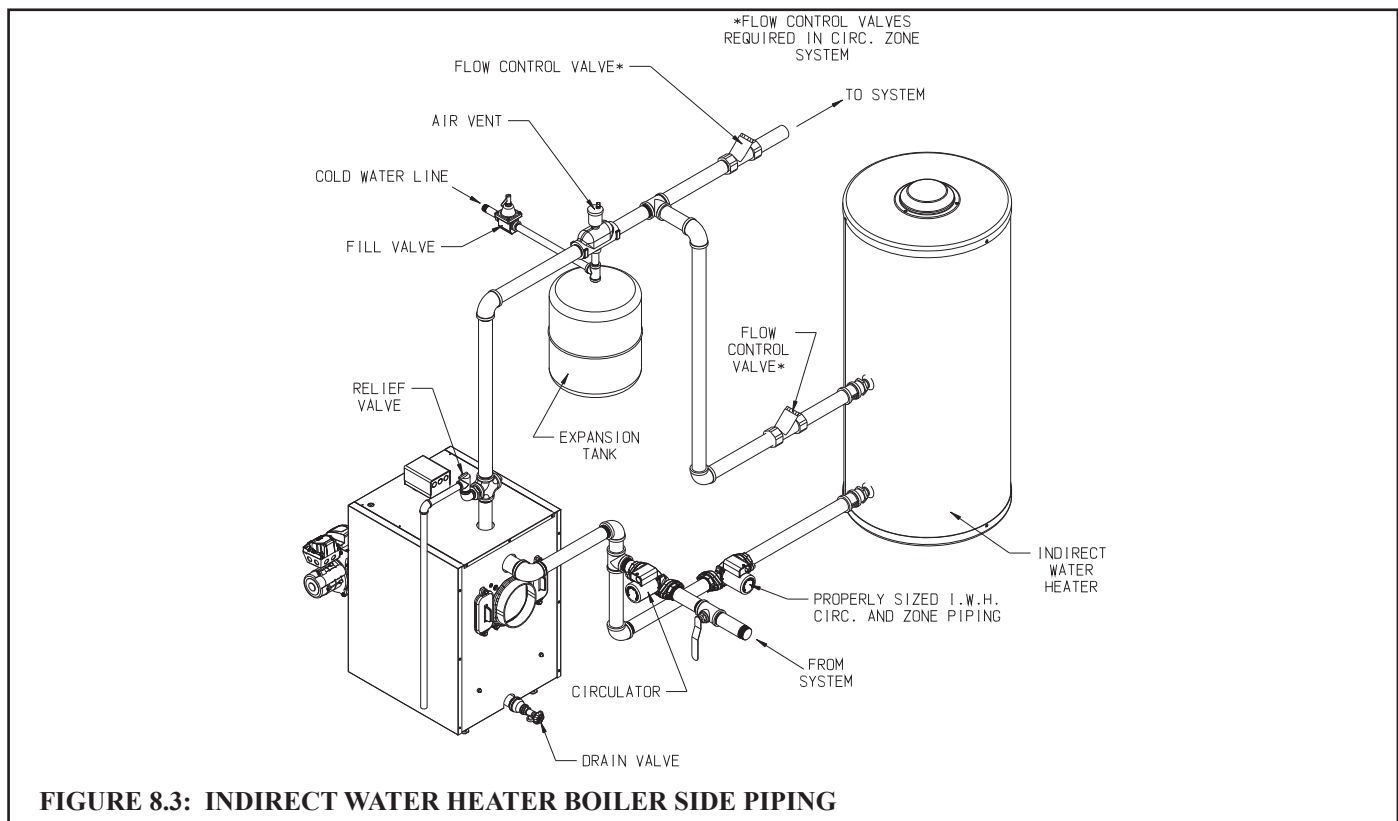

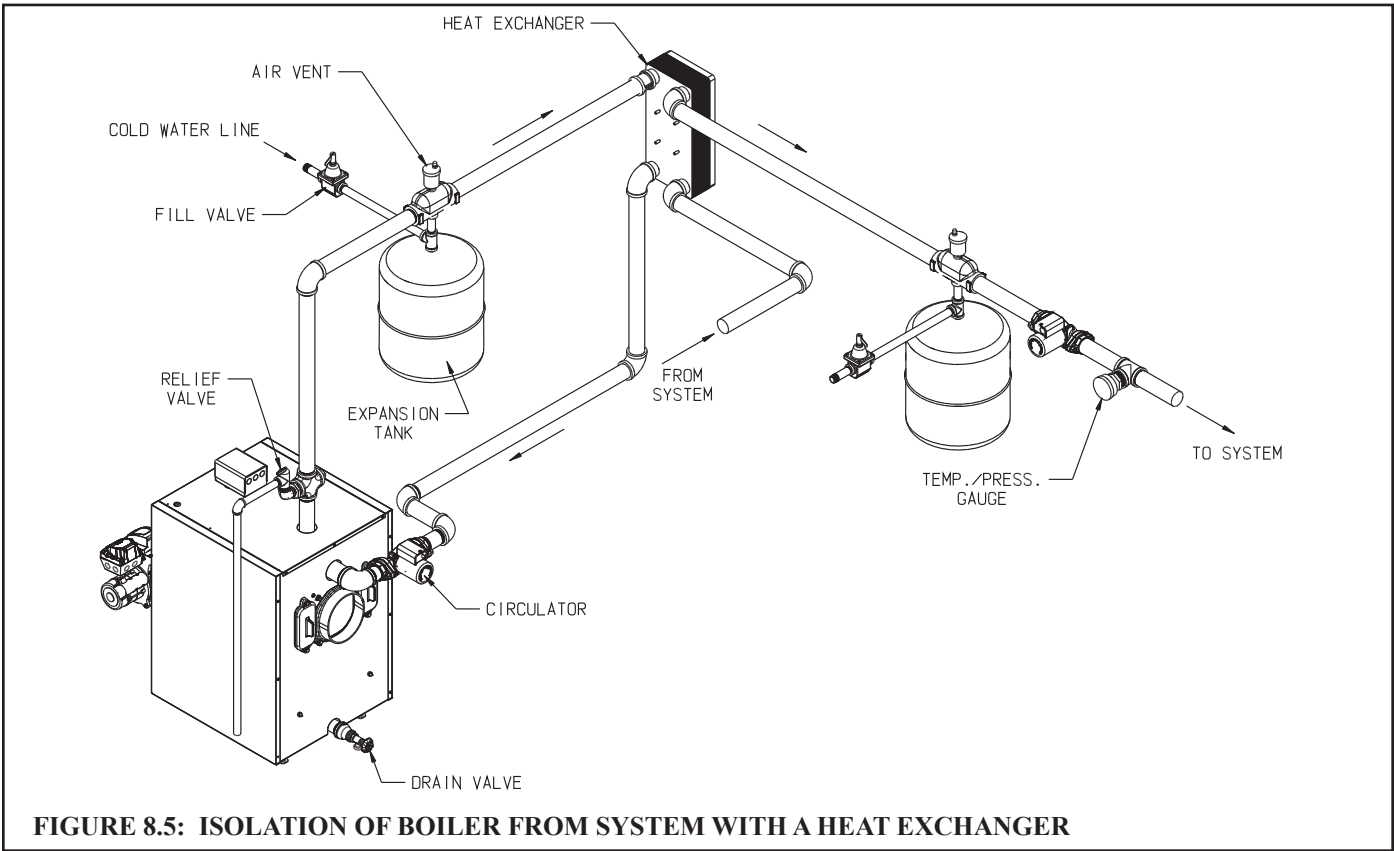
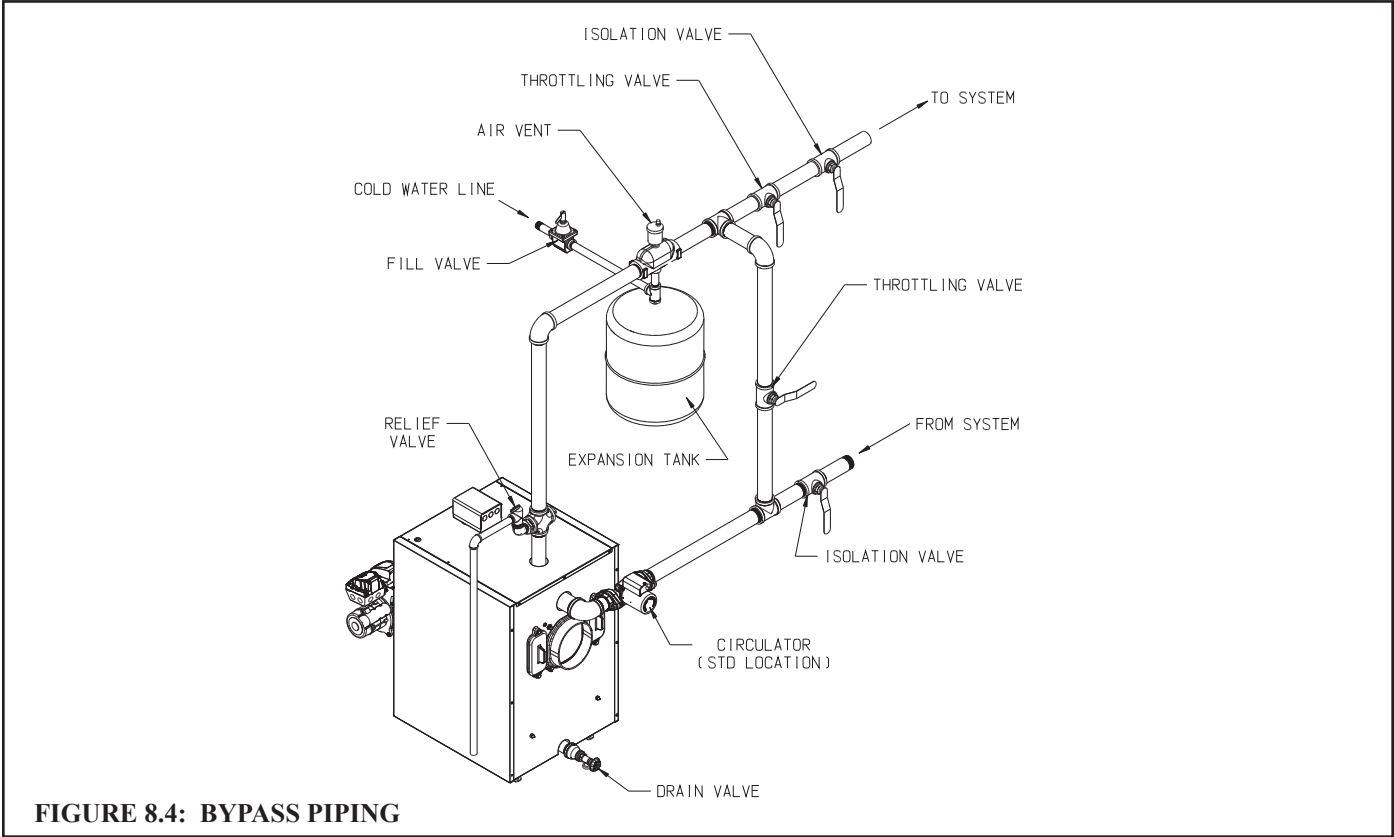

IX Fuel Line Piping



WARNING

- **Under no circumstances can copper with sweat style connectors be used.**
- **Do not use compression fittings.**
- **Oil piping must be absolutely airtight or leaks or loss of prime may result.**
- **Some jurisdictions require the use of a fusible shutoff valve at the tank and/or the burner. In addition, some jurisdictions require the use of a fusible electrical interlock with the burner circuit. Check your local codes for special requirements.**

Fuel line piping design, materials and construction must be in accordance with local building codes, requirements of the local authority having jurisdiction, and, the latest edition of the Standard for the Installation of Oil-Burning Equipment (ANSI/NFPA 31) in the United States and CSA B139-04 for installation in Canada. Refer also to the instruction manuals provided with the burner and oil pump.

Depending on the location of the fuel oil storage tank in relation to an oil burner, there are four types of oil piping systems that may be encountered:

- a) ONE-PIPE GRAVITY SYSTEM - Used when a fuel oil storage tank is positioned above an oil burner fuel pump. See Figure 9.0. A vertical distance from top of the tank to center line of the pump (Dimension 'H') over 8 feet will result in a pump inlet pressure in excess of the 3-psi limit in NFPA-31.
- b) ONE-PIPE LIFT SYSTEM (not recommended) - Used when a fuel oil storage tank is located below an oil burner fuel pump. See Figure 9.1. The vertical distance from bottom of the tank to center line of the pump (Dimension 'H') must not exceed that shown in the pump manufacturer's instructions. Although all oil piping systems must be airtight, one-pipe lift systems are particularly susceptible to nuisance lockout problems if the suction line is not completely airtight. A two-pipe lift system is therefore preferred to a one-pipe lift system.
- c) TWO-PIPE GRAVITY SYSTEM (not recommended) - A vertical distance from top of the tank to center line of the pump (Dimension 'H') over 8 feet will result in a pump inlet pressure in excess of the 3-psi limit in NFPA-31. This type of system should be converted to a one-pipe gravity system, as doing so will result in lower inlet line flow and longer filter life.
- d) TWO-PIPE LIFT SYSTEM - Used when a fuel oil storage tank is located below an oil burner fuel pump suction port. See Figure 9.3. The vertical distance from bottom of the tank to center line of the pump (Dimension 'H') must not exceed that shown in the pump manufacturer's instructions. The maximum permissible distance 'H' allowed is reduced by the number of fittings, filters and valves installed in the line.

Once the type of system has been selected, observe the following:

- 1) Fuel line piping must be airtight. Do not use compression type fittings for tubing connections in fuel line piping. Use only listed flare type fittings. Cast iron threaded fittings shall not be used.
- 2) Piping shall be substantially supported and protected against physical damage and corrosion.
- 3) Refer to supplied oil pump instruction manual for proper connections. On one-pipe systems, ensure that the fuel pump return port plug is tightened securely.
- 4) Some fuel pumps, such as the Suntec A and B series, are supplied with a loose bypass plug which must be installed on two-pipe systems. If such a plug is supplied, install it as shown in the pump manufacturer's instructions. Do not install this bypass plug on one-pipe systems as pump seal damage will result.
- 5) Do not use check valves, especially on gravity feed systems.
- 6) Do not use Teflon tape for threaded connections. Use a non-hardening thread sealant listed for use with #2 fuel oil .

- 7) Attach required piping between burner fuel pump and fuel oil storage tank. Install one fuel shut-off valve near the storage tank and second fuel shut-off valve near the oil burner fuel pump. Use a continuous run of copper tubing having a minimum wall thickness of 0.032". On two-pipe systems, the return line should terminate 3" - 4" above suction line depth within the storage tank. Refer to the pump manufacturer's instructions for tube sizing information.
- 8) Never install manual shut-off valves in the return piping of a two-pipe system.
- 9) Install a listed flexible oil line/s at the burner to facilitate opening of the boiler's swing door.
- 10) All systems require an oil filter. Use of a high efficiency micron filter (Garber or equivalent) in addition to a conventional filter is highly recommended, particularly on FWZ060 and FWZ080.
- 11) Use only #2 Fuel Oil with physical and chemical characteristics meeting the requirements of ASTM D-396.

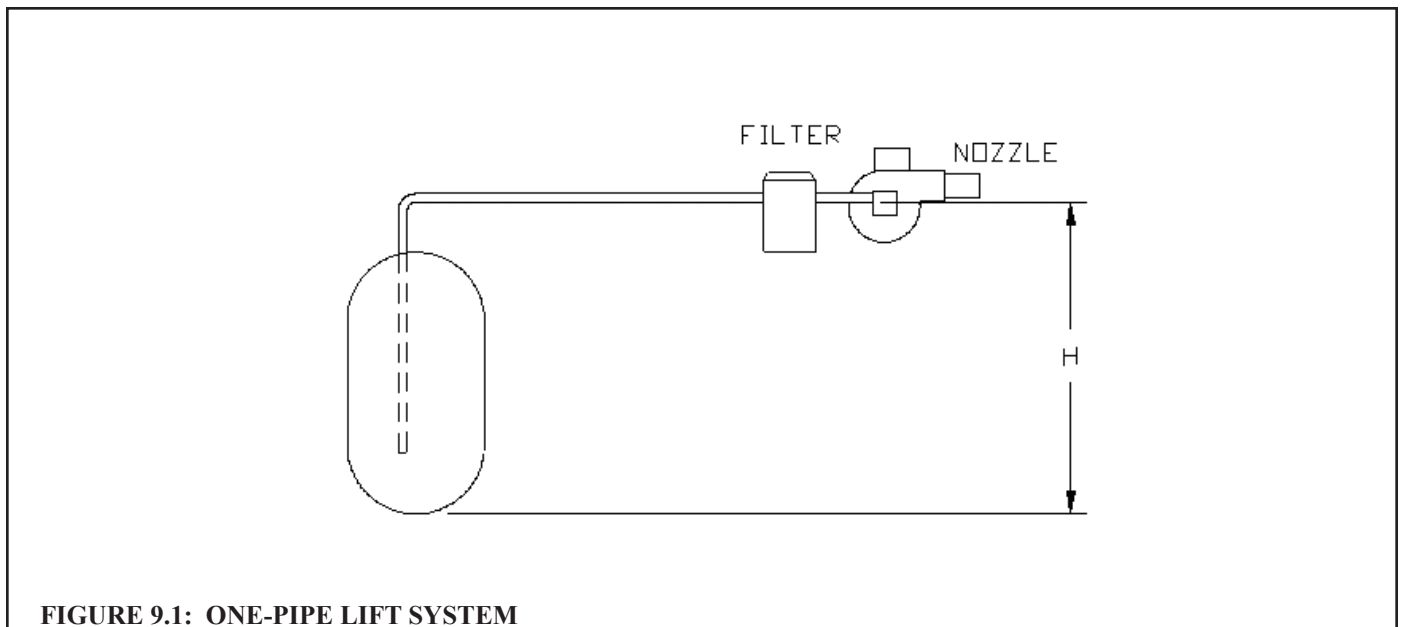
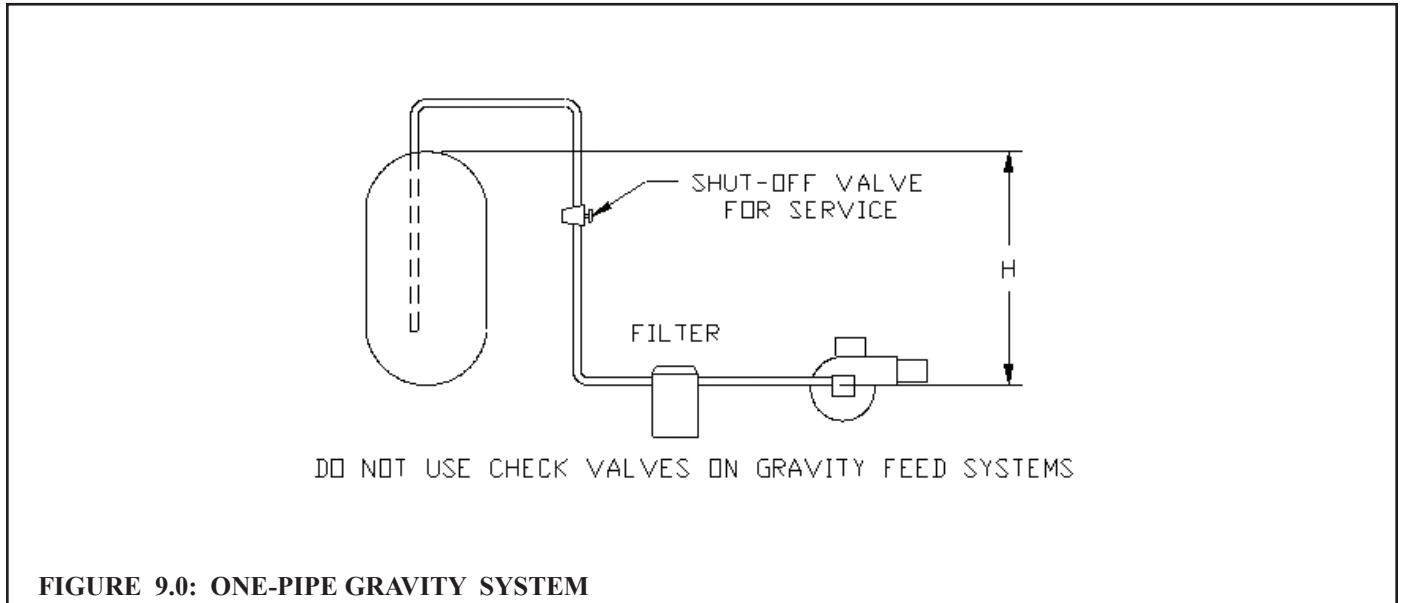

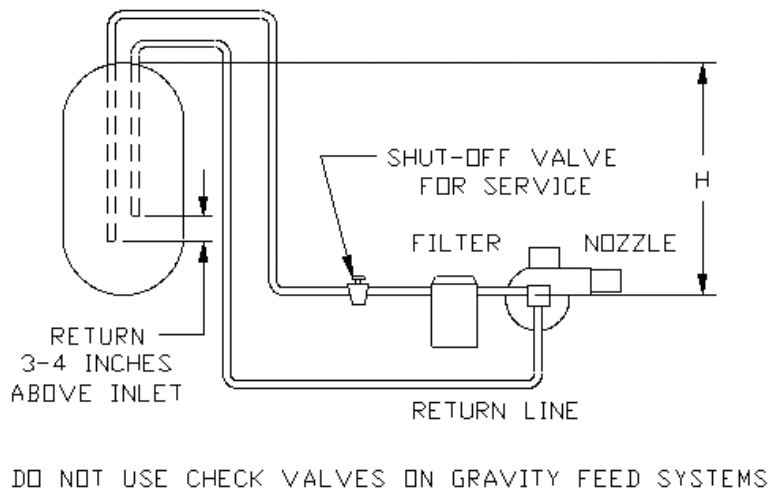

FIGURE 9.2: TWO-PIPE GRAVITY FEED SYSTEM (NOT RECOMMENDED)

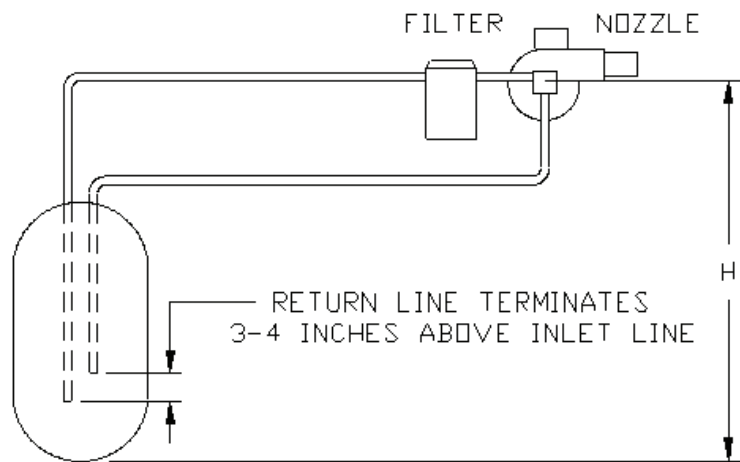

FIGURE 9.3: TWO-PIPE LIFT SYSTEM

X Wiring



WARNING

- **All wiring and grounding must be done in accordance with the authority having jurisdiction or, in the absence of such requirements, with the *National Electrical Code (ANSI/NFPA 70)*.**
- **Disconnect electrical power to the boiler and heating system before servicing. Positively assure that no voltage is present. Lock electrical boxes to prevent someone from inadvertently restoring power before the heating system is safe to operate.**
- **Never defeat or jump out safety devices.**
- **Protect each boiler circuit with a properly sized over-current protection device.**
- **Make electrical connections carefully according to the boiler's wiring diagram and instructions.**
- **Wire additional field supplied safety limits, such as low water cutoffs and temperature limit devices, in series with the 120V circuit used to power the boiler. Do not alter the boiler's factory wiring when adding an additional limit device.**

1) 120 Volt Wiring - The boiler should be provided with its own 15A branch circuit with fused disconnect. 120VAC power connections are made inside the Hydrolevel 3250-Plus hot water boiler control as follows (also see Figures. 10.0 and 10.1):

- Hot ("black") - Terminal "L1"
- Neutral ("white") - Terminal "L2"
- Ground ("green" or bare) - Ground screw on case of 3250-Plus.

The heating circulator is factory wired to the 3250-Plus circulator connections or the boiler is provided with a flexible conduit "whip" that is to be wired to the 3250-Plus circulator connections. If the circulator is not already wired to the control, connect it as follows:

- Circulator "Hot" - Black wire lead from "whip" to C1
- Circulator "Neutral" - White wire lead from "whip" to C2

2) Low Voltage Connections – Low voltage field connections are located as shown in Figure 10.0 and 10.1 and are as follows:

- T-T - Connect to a 24 volt heating thermostat or other "dry contacts" (such as a zone panel end switch) that close upon a call for heat. Follow thermostat manufacturer's instructions. To insure proper thermostat operation, avoid installation in areas of poor air circulation, hot spots (near any heat source or in direct sunlight), cold spots (outside walls, walls adjacent to unheated areas, locations subject to drafts). Provide Class II circuit between thermostat (or zone controls) and boiler.

3) Adding a Second Circulator Zone - The control provided on this boiler can be used to control a second heating or DHW circulator zone. If this is done, make the following 120VAC connections in addition to those described above (also see Figure 10.0):

- Connect a 120VAC heating or DHW thermostat for the second zone between ZC and ZR.
- Connect the DHW circulator or the second heating zone circulator between ZR and L2.

See Part XII of this manual for information on configuring the control to respond properly to the DHW or second heating zone circulator.

NOTICE

- **When making low voltage connections, make sure that no external power source is present in the thermostat circuits. If such a power source is present, it could destroy the boiler's control. One example of an external power source that could be inadvertently connected to the low voltage connections is a transformer in old thermostat wiring.**
- **Do not use the transformer provided on the boiler to power external devices such as zone valves. Doing so may cause damage to the transformer.**

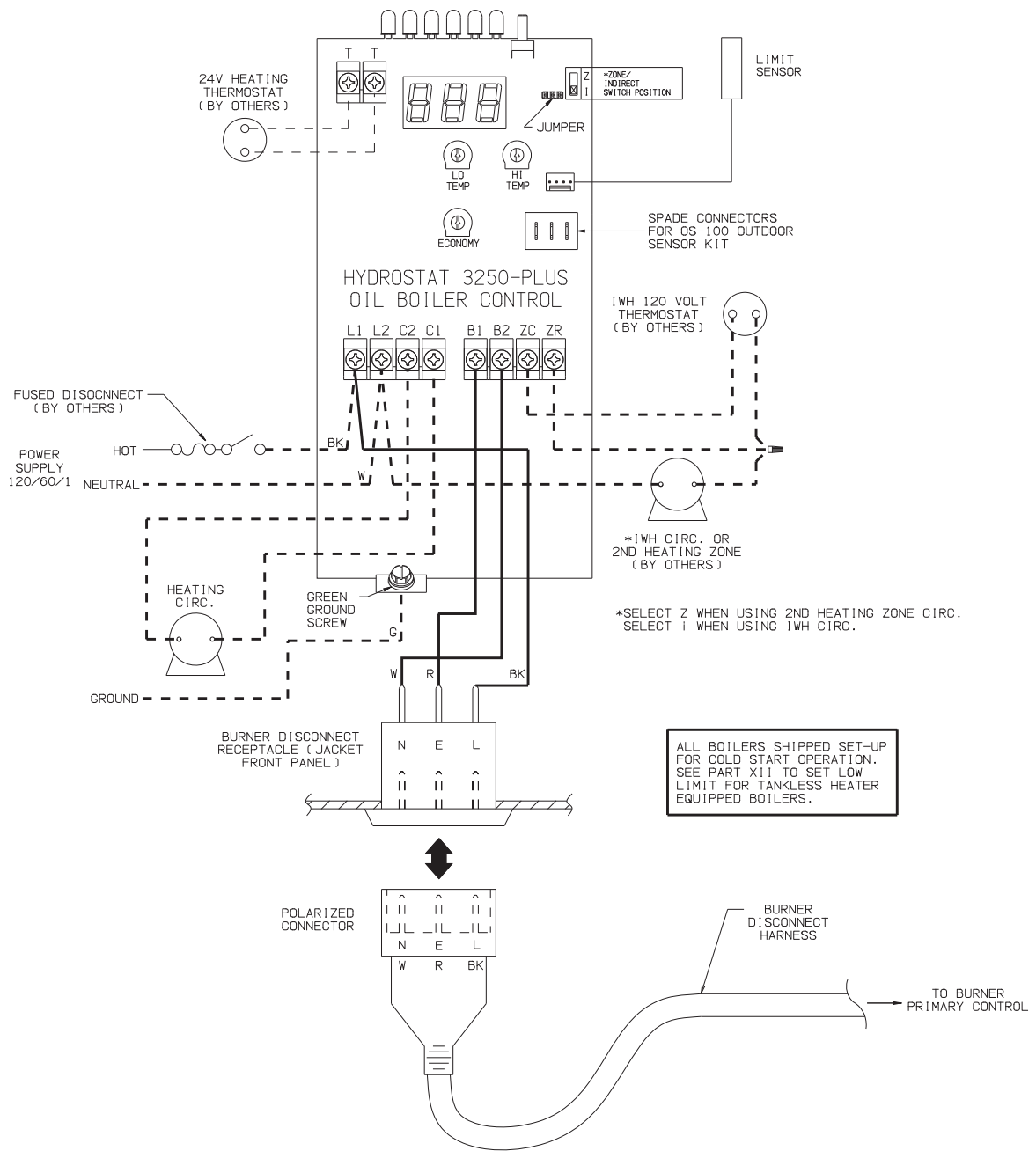

CONNECTIONS DIAGRAM LEGEND

— LOW VOLTAGE FACTORY WIRING SIZE 18 AWG TYPE AWM STRANDED WIRE, 105°C

— LINE VOLTAGE FACTORY WIRING SIZE 14 AWG TYPE AWM STRANDED WIRE, 105°C

- - - LINE VOLTAGE FIELD WIRING

- - - LOW VOLTAGE FIELD WIRING

◄ CONNECTOR

⊞ WIRE NUT

• SPLICE

NOTE:

1. IF ANY OF THE ORIGINAL WIRE SUPPLIED WITH THE APPLIANCE MUST BE REPLACED. IT MUST BE REPLACED WITH THE SAME TYPE SHOWN OR ITS EQUIVALENT.

FIGURE 10.0: WIRING CONNECTIONS DIAGRAM FOR HYDROSTAT 3250-PLUS CONTROL

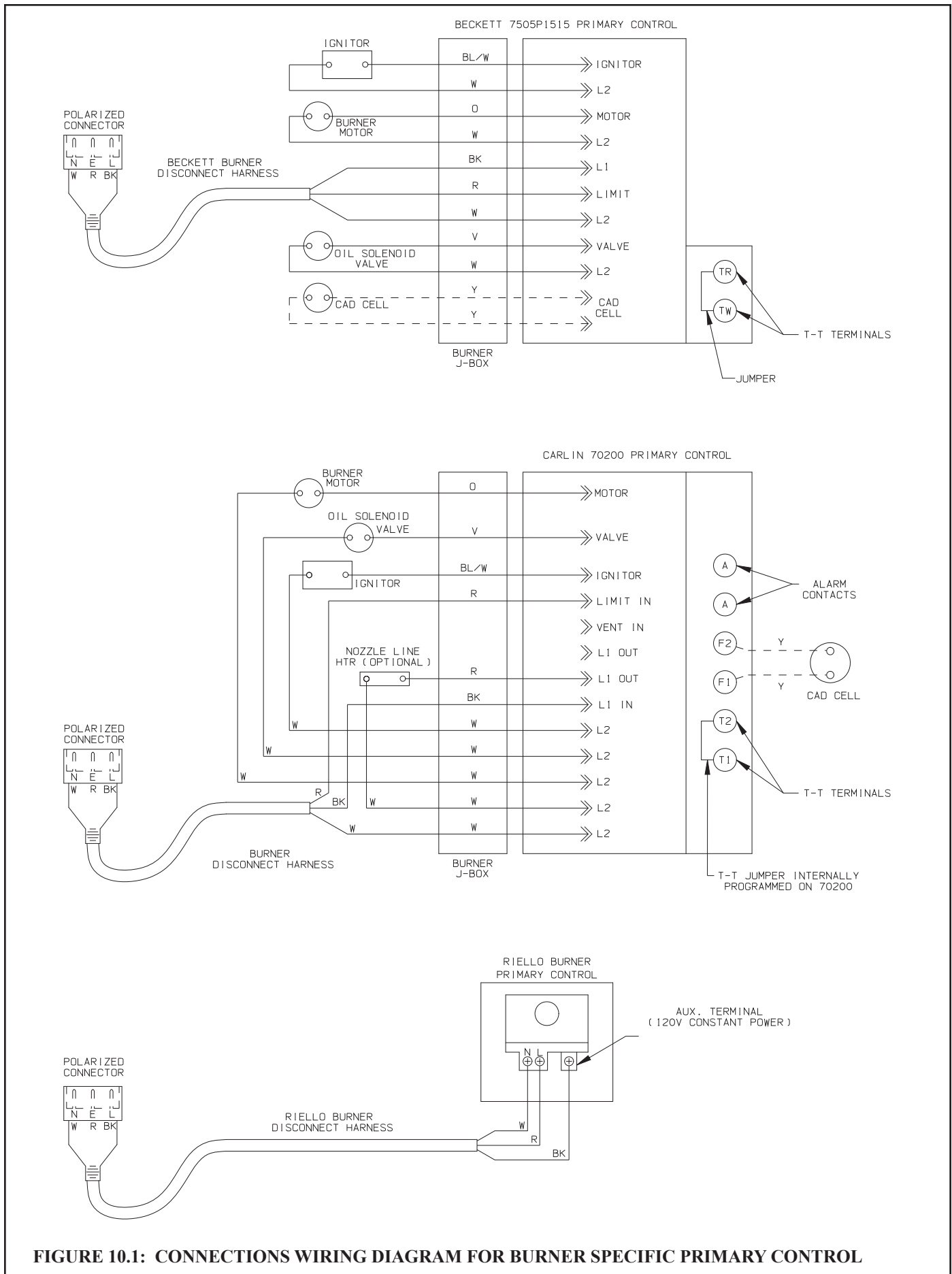

XI Start-up and Checkout

Use the following procedure for initial start-up of the boiler:



WARNING

- **Never attempt to fill a hot empty boiler.**
- **Make sure that the area around the boiler is clear and free from combustible materials, gasoline, and other flammable vapors and liquids.**
- **Safe reliable operation of this boiler requires that the burner be checked and adjusted by a qualified oil serviceman using combustion test instruments.**
- **Failure to perform all of the checks outlined in the following procedure could result in unreliable operation, damage to the boiler not covered under warranty, property damage, or unsafe operation.**
- **All boilers equipped with burner swing door have a potential hazard which can cause severe property damage, personal injury or loss of life if ignored. Before opening swing door, turn off service switch to boiler to prevent accidental firing of burner outside the combustion chamber. Be sure to tighten swing door fastener completely when service is completed. In addition, the burner power cord will have to be disconnected from the receptacle in the front jacket.**

- 1) Ensure that the boiler and entire heating system are filled with water.
- 2) Check all new piping for leaks and purge all heating system piping of air. Clean heating system if system water is dirty.
- 3) Verify that the venting system is properly installed and free of obstructions prior to start-up of the boiler. Refer to Section VII for more information.
- 4) Inspect all wiring for loose or uninsulated connections, proper size fuses installed, etc.
- 5) Verify that oil tank is filled with #2 fuel oil meeting ASTM D396 specifications, oil piping has been tested and is air tight, and shutoff valve(s) are closed.
- 6) Check initial settings of oil burner air band and air shutter, head setting etc., and readjust if needed. See Table 11.1 for setup and combustion data pertaining to a particular boiler/ burner combination.
- 7) Ensure that burner is tightly secured to the burner swing door creating an airtight seal.
- 8) Attach plastic hose to oil pump vent fitting and provide a container to catch oil during oil pump bleeding procedure.
- 9) Install 0-200 PSI pressure gauge into oil pump gauge port.
- 10) Open all oil line shutoff valves.
- 11) Adjust system thermostat to highest setting.
- 12) Turn the service switch to "ON" position.
- 13) Crack open vent fitting on the oil pump and allow burner to run until a solid oil stream, free of air bubbles, flows for 15 seconds into container. As the vent fitting is closed, the burner should fire and flame should be visible through observation port immediately (or after prepurge timing has expired, if a burner is so equipped). Refer to burner instructions for more details.
- 14) Immediately upon firing the boiler, check the smoke level. If the smoke level is in excess of a #1, open the air adjustment to bring the smoke level below a #1.
- 15) Make sure that the oil pressure matches that shown in Table 11.1 for the burner supplied. Adjust pressure if required.
- 16) Check the vacuum at the inlet of the fuel pump. Make sure that the vacuum does not exceed the fuel pump manufacturer's limit (consult the pump manufacturer's instructions).
- 17) Close the flame observation cover.

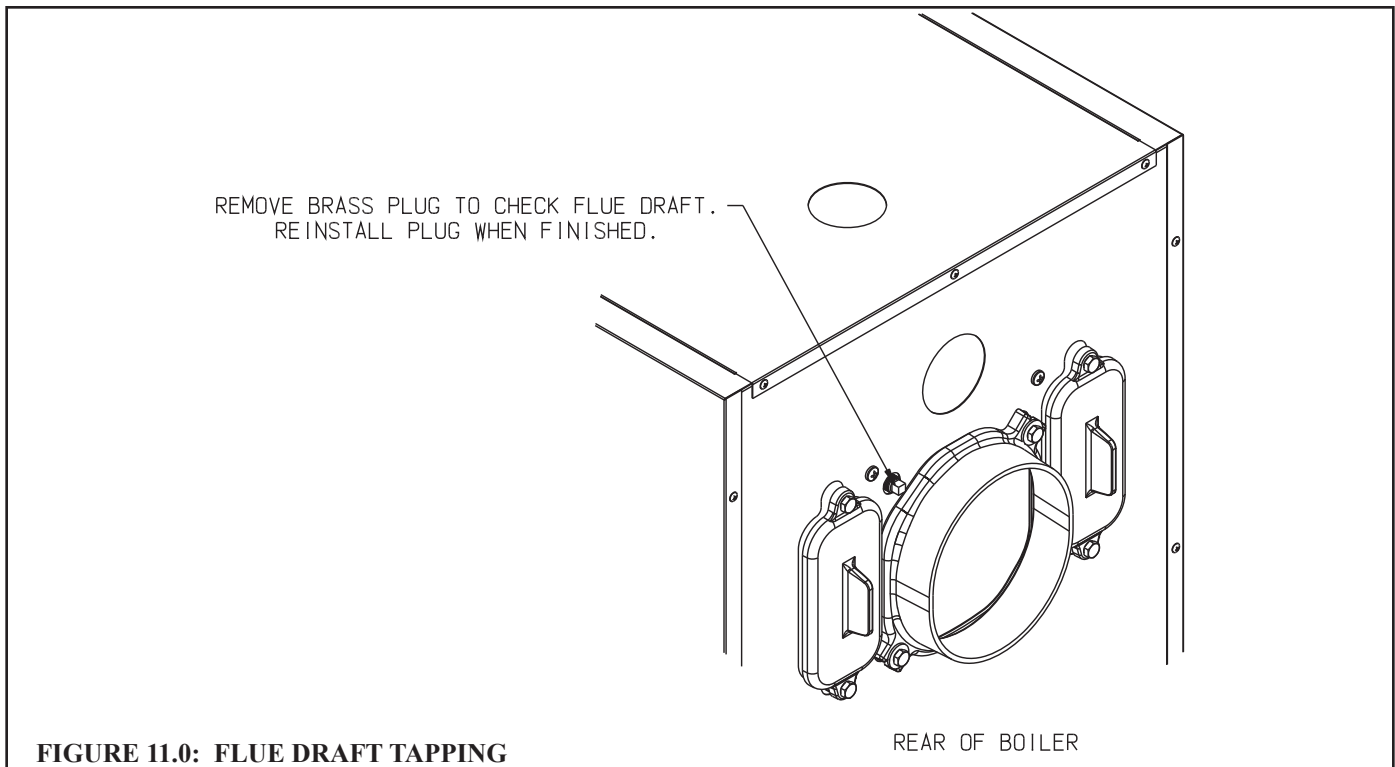

FIGURE 11.0: FLUE DRAFT TAPPING

- 18) After chimney has warmed-up for at least 5 minutes, adjust barometric draft regulator to obtain a draft at the 1/4" tapping shown in Figure 11.0 that is within the range shown in Table 11.1. DRAFT AT THIS LOCATION MUST NEVER BE POSITIVE.
- 19) Check the CO₂ and confirm that it is between the minimum and maximum limits shown in Table 11.1. Adjust if necessary.
- 20) Verify that the smoke level still does not exceed #1 and that the draft in the breech still within the range prescribed by Table 11.1.
- 21) Turn off the burner and remove pressure gauge. Install and tighten gauge port plug, then restart the burner.
- 22) Check for clean cutoff of the burner. Air in the oil line between fuel pump and nozzle will compress, while burner is running, and expand when burner shuts off, causing nozzle drip after burner stops. Cycle burner on and off 5 to 10 times to purge air completely.
- 23) Check thermostat operation by raising or lowering its set point as required, cycling burner on and off.
- 24) Verify primary control operation and safety features according to procedure outlined in the instructions furnished with the burner.
- 25) Check high limit control operation. Jump thermostat terminals and allow burner to run until boiler water temperature exceeds high limit setting. The burner should shut down, and circulator continue running. Allow the temperature to drop below the control setting. The burner must restart. Boiler installation is not complete unless these checks are made and are satisfactory. Remove thermostat jumper and reconnect thermostat upon check completion.
- 26) After the boiler has operated for approximately 30 minutes, check the boiler and heating system for leaks. Repair any leaks found at once.
- 27) After the above checks have been completed, leave thermostat(s) at desired setting. Leave all instructions provided with the boiler with owner or in boiler room, displayed near boiler.



WARNING

Attempts to use burners or burner configurations other than those shown in Table 11.1 could result in reliability problems, property damage, personal injury or loss of life.

TABLE 11.1a: BECKETT BURNER CONFIGURATION AND SETUP DATA

BOILER MODEL	FWZ060	FWZ080	FWZ081	FWZ100	FWZ130	FWZ160
BURNER MODEL	AFG	AFG	AFG	AFG	AFG	AFG
AIR TUBE COMBO	70MQASN	70MMAQN	70MMAQN	70MMAQN	70MLASN	70MLASN
HEAD TYPE	L2	L1	L1	L1	V1	V1
STATIC PLATE	3-3/8U	3-3/8U	3-3/8U	3-3/8U	NONE	2-3/4M
LOW FIRING RATE BAFFLE	BECKETT SILVER (5880)	BECKETT SILVER (5880)	BECKETT SILVER (5880)	NONE	NONE	NONE
INSERTION LENGTH	2.0"	2.0"	2.0"	2.0"	2.0"	2.0"
PITCH ANGLE	0	0	0	0	0	0
STANDARD NOZZLE	DELAVAN 0.50 X 45W	DELAVAN 0.65 X 60A	DELAVAN 0.65 X 60A	DELAVAN 0.85 X 60B	DELAVAN 1.10 X 60B	DELAVAN 1.35 X 60B
PUMP PRESSURE (psi)	180	150	150	150	150	150
HEAD SETTING	FIXED	FIXED	FIXED	FIXED	0	1
STARTING: SHUTTER SETTING	8	10	10	7	8	9
BAND SETTING	0	1	1	1	2	5
DRAFT IN FLUE (in w.c.)	0 to -0.02	0 to -0.02	0 to -0.02	0 to -0.02	0 to -0.02	0 to -0.02
MAX SMOKE (Bacharach Scale)	#1	#1	#1	#1	#1	#1
FLUE CO ₂ (%)						
MIN.	11.5	11.5	11.5	11.5	11.5	11.5
MAX.	12.8	12.8	12.8	12.8	12.8	12.8

TABLE 11.1b: RIELLO BURNER CONFIGURATION AND SETUP DATA

BOILER MODEL	FWZ081	FWZ100	FWZ130	FWZ160
BURNER MODEL	F3	F5	F5	F5
TURBULATOR DISK	5 SLOT	9 SLOT	9 SLOT	9 SLOT
COMBUSTION HEAD	VSBT	10" LBT	6" SBT	VSBT
STANDARD NOZZLE	DELAVAN 0.60 X 60A	DELAVAN 0.85 X 60B	DELAVAN 1.10 X 60B	DELAVAN 1.35 X 60B
INSERTION LENGTH	2.5"	10"	3.5"	2.25"
PUMP PRESSURE (psi)	175	145	150	145
TURBULATOR SETTING	3.0	2.0	4.0	4.0
AIR GATE SETTING	2.4	2.5	3.75	4.0
DRAFT IN FLUE (in w.c.)	0 to -0.02	0 to -0.02	0 to -0.02	0 to -0.02
MAX SMOKE (Bacharach Scale)	#1	#1	#1	#1
FLUE CO ₂ (%)				
MIN.	11.5	11.5	11.5	11.5
MAX.	12.8	12.8	12.8	12.8

TABLE 11.1c: CARLIN BURNER CONFIGURATION AND SETUP DATA

BOILER MODEL	FWZ081	FWZ100	FWZ130	FWZ160
BURNER MODEL	EZ1-LF	EZ1-LF	EZ1-LF	EZ-66
BLENDER	28 HOLE	NONE	NONE	NONE
CARLIN AIR TUBE NUMBER	50989	50989	50989	51198
STANDARD NOZZLE	DANFOSS 0.60 X 60AS	HAGO 0.75 X 60B	HAGO 1.00 X 45B	HAGO 1.35 X 45B
INSERTION LENGTH	2.62"	2.62"	2.62"	2.62"
PITCH ANGLE	1°	1°	1°	1°
PUMP PRESSURE (psi)	175	175	175	140
HEAD SETTING	2	2	3	5
STARTING AIR BAND SETTING	45%	35%	45%	60%
DRAFT IN FLUE (in w.c.)	0 to -0.02	0 to -0.02	0 to -0.02	0 to -0.02
MAX SMOKE (Bacharach Scale)	#1	#1	#1	#1
FLUE CO ₂ (%)				
MIN.	11.5	11.5	11.5	11.5
MAX.	12.8	12.8	12.8	12.8

XII Operation

A. General Information

This boiler uses the Hydrolevel Hydrostat® model 3250-Plus control to provide control of boiler water temperature, as well as to manage demands for up to two circulator zones. In addition, this control also provides protection against low water conditions.

This boiler complies with the 2007 Energy and Independence Security Act, using an “Economy” feature, which raises or lowers the target boiler water temperature during a call for space heat based on thermostat cycling patterns. For additional information see Part B of this section.

IMPORTANT

This boiler is equipped with a feature that saves energy by reducing the boiler water temperature as the heating load decreases. This feature is equipped with an override which is provided primarily to permit the use of an external energy management system that serves the same function. THIS OVERRIDE MUST NOT BE USED UNLESS AT LEAST ONE OF THE FOLLOWING CONDITIONS IS TRUE:

- **An external energy management system is installed that reduces the boiler water temperature as the heating load decreases.**
- **This boiler is not used for any space heating.**
- **This boiler is part of a modular or multiple boiler system having a total input of 300,000 BTU/hr or greater.**
- **This boiler is equipped with a tankless coil.**

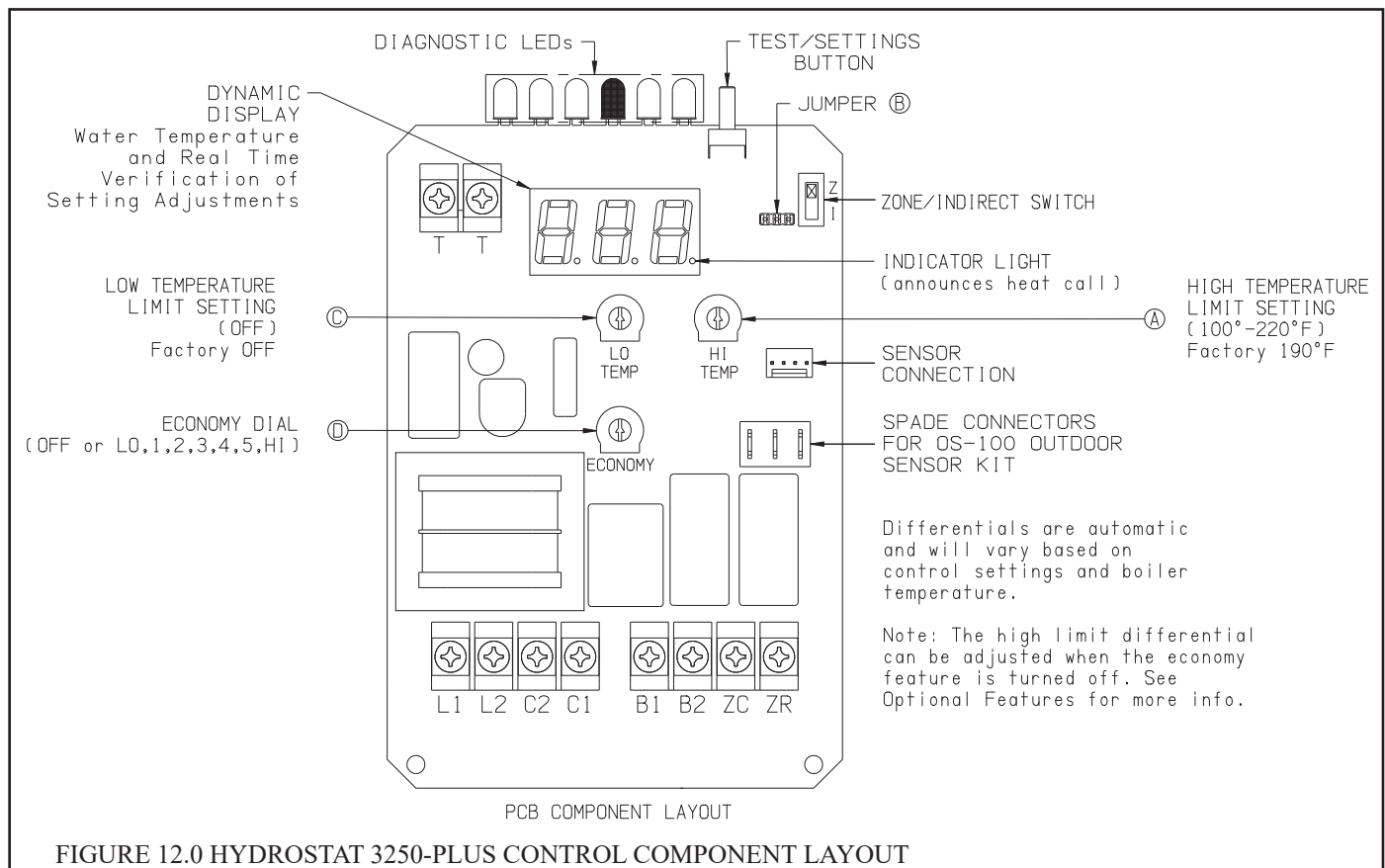

B. Setting the Control

NOTE: Settings can be checked using the TEST/SETTINGS button located on the top right of the control. See page 33 for details.

- 1) Setting the High Limit - The high limit is factory set at 190°F. To adjust, turn the HI TEMP dial **A** until the desired setting is displayed. (Setting range: 100°-220°F) See Figure 12.0.
- 2) Setting the Low Limit - The low limit is factory set to OFF and should not be adjusted.

NOTICE

For proper operation low limit setting must be at least 10F below high limit setting.

- 3) Setting the Economy Feature - The Economy Feature is factory set for a 1 zone heating system. To adjust, turn the ECONOMY Dial **D** until the number displayed equals the number of heating zones. Do not include indirect water heaters in the number of heating zones. The Economy Feature conserves fuel by analyzing thermostat activity and continually evaluating how much heat the house requires. When it is very cold outside, the heat demand is high and the control will raise the boiler's target temperature to provide needed heat to the home. When the outside temperature is milder, the heat demand is lower. During these periods, the control will lower the boiler's target temperature – saving fuel – while continuing to provide comfort to the house. If the heating system is unable to supply needed heat to the house, the ECONOMY Dial should be turned to a lower setting (example: In a three zone house, turn the dial to 2 or 1). Conversely, if the boiler provides adequate heat, added fuel savings can be achieved by selecting a higher setting (example: 4 or 5). If the heating and indirect water heater signals were not separated when wiring the control, the Economy Feature should be turned OFF to ensure the boiler supplies adequate temperature to heat the indirect tank. See Figure 12.0 & Table 12.1.

SETTING	TABLE 12.1 ECONOMY SETTING RECOMMENDATIONS
OFF	Disables economy function. Will allow boiler to fire until hi limit temp is reached and re-fire with a 10° subtractive differential.
LO	Provides lowest level of fuel savings. Use this setting only if the house does not stay warm at higher settings.
1	Recommended setting for single zone systems
2	Recommended setting for two zone systems
3	Recommended setting for three zone systems
4	Recommended setting for four zone systems
5	Recommended setting for five zone systems
HI	Provides highest level of fuel savings

- 4) Setting the Zone/Indirect Switch - See Figure 10.0.

NOTICE

IMPORTANT: When installing with an indirect water heater, the Zone/Indirect Switch must be set in the I position. When set in the I position, calls to ZC-ZR will bypass the thermal targeting feature and allow the boiler to fire to the high limit setting to heat the indirect tank. The indirect signal must be separate from all heating zone signals.

NOTE: DHW Priority: During a call from an indirect water heater, the control will de-energize the circulator contacts (C1/C2) to heat only the indirect tank ensuring an adequate supply of domestic hot water. The control will re-energize the circulator when the indirect tank is satisfied or if the boiler temperature reaches 170°F. If the indirect call continues for 45 minutes, the control will override the priority function energizing the circulator to provide space heating.

C. Optional Features

NOTE: The Program Mode - *Pr* - is accessed by turning the LO TEMP dial to a position just above OFF.

- 1) **Thermal Pre-Purge** - Thermal Pre-Purge is designed to maximize boiler efficiency. When activated, the control will supply latent heat that may remain in the boiler from a previous run cycle to the heating zone that is now calling. The control monitors how quickly the boiler temperature is declining and activates the burner only when it determines that the latent heat is insufficient to satisfy the call. During the purge cycle, the display will indicate Pur. This feature works with single-zone and multi-zone heating systems utilizing circulators or zone valves. No change in wiring is needed.

To activate Thermal Pre-Purge

1. Turn the LO TEMP dial to access the Program Mode – indicated in the display as *Pr*
 2. Turn the HI TEMP dial to select feature *l*
 3. Push the Test/Settings Button to turn Thermal Pre-Purge *on* or *OFF*
 4. Reset LO TEMP and HI TEMP settings to desired temperatures (see page 28)
- 2) **Degrees Fahrenheit or Celsius** - The control has the ability to operate in degrees Fahrenheit or Celsius. When operating in Celsius, a *c* will appear in the display next to the temperature whenever the temperature is below 100 degrees.

To change between degrees Fahrenheit and degrees Celsius

1. Turn the LO TEMP dial to access the Program Mode – indicated in the display as *Pr*
 2. Turn the HI TEMP dial to select feature *2*
 3. Push the Test/Settings Button to *c* for Celsius or *F* for Fahrenheit
 1. Reset LO TEMP and HI TEMP settings to desired temperatures (see page 28)
- 3) **Manual Reset Low Water Cut-Off** - The low water cut-off operation on the HydroStat can be set to operate in automatic (default) or manual reset mode. When in manual reset mode, the control will shut-down the burner immediately when a low water condition is detected. If the low water condition is sustained for 30 seconds, the low water light will blink, indicating that the control has locked out the burner. The control can only be reset by pushing the Test Settings button on the top of the control. The manual reset feature meets CSD-1 code requirements.

To activate Manual Reset LWCO mode

1. Turn the LO TEMP dial to access the Program Mode – indicated in the display as *Pr*
2. Turn the HI TEMP dial to select feature *3*
3. Push the Test/Settings Button to *A* for Automatic Reset Mode or *b* for Manual Reset Mode
4. Reset LO TEMP and HI TEMP settings to desired temperatures (see page 28)

To Test the Manual Reset Feature: Press and hold the Test/Settings button located on the top of the control for 30 seconds to simulate a low water condition. After 30 seconds, the Low Water light will blink indicating that the control is locked out. To reset the lock-out condition, press the Test/Settings button momentarily.

- 4) **Circulator Activation Options** - When in the default mode, the control activates the circulator (C1/C2 contacts) on calls to **TT**. The control can be programmed to activate the circulator on calls to **ZC/ZR** in place of, or in addition to, calls to **TT**.

To change how the Circulator is activated

1. Turn the LO TEMP dial to access the Program Mode – indicated in the display as *Pr*
2. Turn the HI TEMP dial to select feature *4*
3. Push the Test/Settings Button to select between the following options:
 - A* - Circulator on **TT** call only
 - b* - Circulator on **ZC/ZR** call only
 - l* - Circulator on both **TT** & **ZC/ZR** calls
4. Reset LO TEMP and HI TEMP settings to desired temperatures (see page 28)

- 5) Circulator Hold Off (Enhanced Condensing Protection) - To reduce the potential for condensing, on a call for heat the control will allow the boiler to heat to 125°F prior to energizing the circulator. Once energized, the circulator will remain on for the duration of the heating call unless the boiler temperature drops below 115°F. If this occurs, the circulator will re-energize when the boiler returns to 125°F. Circulator Hold Off will expire after 15 minutes.

To activate Circulator Hold Off

1. Turn the LO TEMP dial to access the Program Mode – indicated in the display as *Pr*
2. Turn the HI TEMP dial to select feature 5
3. Push the Test/Settings Button to turn Circulator Hold Off *ON* or *OFF*
4. Reset LO TEMP and HI TEMP settings to desired temperatures (see page 28)

- 6) Not available on this control.

- 7) Not available on this control.

- 8) Well Type - Hydrolevel Electro-Well (factory installed on boiler).

- 9) High Limit Differential - When the Economy feature is on, the control's Thermal Targeting feature actively sets varying differentials based on system conditions. This option allows for selecting a 10, 20 or 30 degree fixed differential when the Economy feature is turned OFF. These optional differential settings are subtractive from the HIGH LIMIT setting. Note: If the Economy feature is on, this setting will be overridden by the control's Thermal Targeting function.

To change the High Limit Differential

1. Turn the LO TEMP dial to access the Program Mode – indicated in the display as *Pr*
2. Turn the HI TEMP dial to select feature 9
3. Push the Test/Settings Button to select a high limit differential of *10*, *20*, or *30*
4. Reset LO TEMP and HI TEMP settings to desired temperatures (see page 28)

- dEF*) Restore Factory Default Settings

To restore all features to the factory default settings (see Table 12.2 for default settings)

1. Turn the LO TEMP dial to access the Program Mode – indicated in the display as *Pr*
2. Turn the HI TEMP dial to select feature *dEF*
3. Push the Test/Settings Button to *Y* to reset all features to the default settings.
4. Reset LO TEMP and HI TEMP settings to desired temperatures (see page 28)

TABLE 12.2 DEFAULT SETTINGS				
Dial Setting	Feature	Options	Description	Default Setting
1	Thermal Pre-Purge	OFF on	Purge Inactive Purge Active	OFF
2	Fahrenheit or Celsius	F C	Degrees Fahrenheit Degrees Celsius	F
3	LWCO Manual or Automatic Reset	A B	Automatic Reset Manual Reset	A
4	Circulator Options	A B C	Circulator operation on TT call only Circulator operation on ZC/ZR call only Circulator operation on call from either	A
5	Circulator Hold Off	on OFF	Circulator Hold Off - Active Circulator Hold Off - Inactive	on
6	Not available on this control			
7	Not available on this control			
8	Well Type	A B	Hydrolevel Electro-Well (supplied with boiler) Standard Immersion Well	A
9	High Limit Differential	10 20 30	10° Differential 20° Differential 30° Differential	10
dEF	Restore Factory Defaults	Y n	Restore Defaults Do Not Restore Defaults	n

D. LED Legend and TEST/SETTINGS Button (Figure 12.3)

- 1) **TEMP - ACTIVE** - Indicates that the control is powered and that the temperature function is active.
- 2) **TEMP - HI TEMP** - Illuminates when the boiler water temperature reaches the high limit setting. It will remain lit until the water temperature falls 10°. The control prevents burner operation while this LED is on. See Differential explanation on page 28.
- 3) **LWCO - ACTIVE** - Indicates that the low water cut-off (LWCO) function of the control is active.
- 4) **LWCO - LOW WATER** - Indicates that the boiler is in a low water condition. The control will prevent burner operation during this condition. If the LOW WATER light is blinking, the control has been programmed to provide lock-out protection in the event a low water condition is detected (see Manual Reset Low Water Cut-Off on page 30). Pressing the TEST/SETTINGS button will reset the control.



WARNING

If the Hydrostat is found to be in a low water condition:

- Have the system checked by a qualified HVAC service technician before attempting to restore operation.
- Do not add water to the boiler until it has fully cooled.

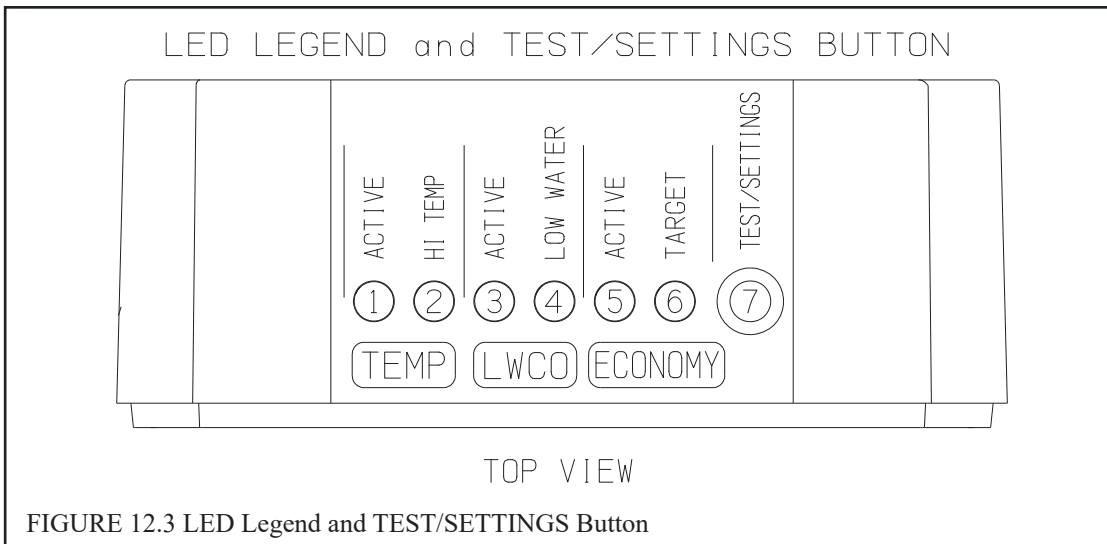

- 5) **ECONOMY - ACTIVE** - Indicates that the thermal targeting function is active and the control will reduce boiler temperature to conserve fuel. The Economy feature is activated using the ECONOMY dial. (See “Setting the Economy Feature” on page 29 for more information).
- 6) **ECONOMY - TARGET** - When the Economy feature is active, the control continually sets target temperatures below the high limit setting to maximize fuel efficiency. When the boiler water reaches the target temperature, the LED illuminates and the burner will shut down. The boiler water will continue to circulate and heat the house as long as the thermostat call continues. The LED will stay lit until the boiler temperature drops below the differential set point at which point the boiler will be allowed to fire again. See Differential explanation on page 31. **NOTE:** This LED illuminates regularly during normal boiler operation.
- 7) **TEST/SETTINGS BUTTON - To Test Low Water Cut-Off:** Press and hold the Test/ Settings button for 5 seconds. The display will read LLO . The red Low Water light should illuminate and the burner circuit (**B1** and **B2**) should de-energize. **NOTE:** The control must be installed with a Hydrolevel Electro-Well™ for low water cut-off functionality (see page 28 for more details). **To View Current Settings:** Press and release the Test/Settings Button in short intervals to sequentially display the following settings:

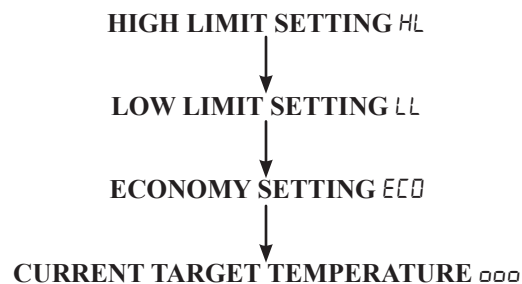

The display will return to boiler temperature (default) if Test/Settings Button is not pressed for 5 seconds.

XIII Service and Maintenance



WARNING

All boiler cleaning must be completed with the burner service switch turned off. Boilers equipped with burner swing door have a potential hazard which can cause severe property damage, personal injury or loss of life if ignored. Before opening swing door, turn off service switch to boiler to prevent accidental firing of burner outside the combustion chamber. Disconnect the burner plug from the receptacle in the front jacket. Be sure to tighten the swing door fastener completely when service is completed.

The following procedure should be performed on an annual basis:

- 1) Turn off electrical power and oil supply to the boiler.
- 2) Clean the boiler as follows:
 - a) Remove the two 3/8" bolts from either side of the swing door and open the door to access the combustion chamber.
 - b) Remove the two smoke box clean-out covers from the rear smoke box by removing the four 5/16" bolts. It is not necessary to remove the vent connector from the smoke box to clean boiler however if there is heavy soot accumulation in the boiler remove the vent connector to inspect the base of the chimney for condensate or accumulation of debris.
 - c) Remove the baffles (if installed) from the flue passages.
 - d) Clean the 3rd Pass - Insert a 2" dia x 42" long wire or fiber bristle brush into one of the two 3rd flue passes. Using long strokes push the brush all the way through the boiler until the brush has exited the smoke box opening. Pull the brush all the way forward until it has exited the front of the boiler. Continue this operation for the entire height of the flue way until clean. Repeat the operation for the other 3rd pass flue way.
 - e) Clean the 2nd Pass - Insert a 2" dia x 42" long wire or fiber bristle brush into one of the two 2nd flue passes. Using long strokes push the brush all the way through the boiler until the brush hits the back wall of the reversing chamber. Pull the brush all the way forward until it has exited the front of the boiler. Continue this operation for the entire height of the flue way until clean. Repeat the operation for the other 2nd pass flue way.
 - f) Vacuum to loose debris in the bottom of the combustion chamber and smoke box
 - g) Clean the Combustion Chamber - Use a wire or fiber bristle brush to clean the surfaces of the combustion chamber. Vacuum all loose debris in the chamber.
 - h) Check condition of the burner swing door insulation and rope gaskets for signs of damage; replace if required.
 - i) Check burner head for signs of deterioration. Clean the head of any deposits.
 - j) Insert baffles (if originally installed) into the correct flueways.
 - k) Attach the smoke box clean-out covers onto the rear of the boiler using the 5/16" bolts originally removed. Verify that the rope gasket is in good order before assembly. Replace rope gasket if necessary. Do not over tighten. The bolts should be snug but not bottomed out.
 - l) Close the swing door and tighten it with the 3/8" bolts originally removed. When securing the burner swing door make sure the door is drawn-in equally on both sides by alternating the tightening method for right side to left side. Do not over tighten. The rope gasket will provide sufficient seal when door is snugged into place.
 - m) Ensure all vent piping joints are gas tight and secured with sheet metal screws.

IMPORTANT

Clean the boiler even if there are no significant soot deposits. Failure to remove all sulfur and ash deposits annually can cause severe corrosion damage.



WARNING

The boiler must be connected to an approved chimney in good condition. Serious property damage could result if the boiler is connected to a dirty or inadequate chimney. The interior of the chimney flue must be inspected and cleaned before the start of the heating season and should be inspected periodically throughout the heating season for any obstructions. A clean and unobstructed chimney flue is necessary to allow noxious fumes that could cause injury or loss of life to vent safely and will contribute toward maintaining the boiler's efficiency.

- 3) Inspect the vent system:
 - a) Make sure that the vent system is free of obstructions and soot.
 - b) Make sure that all vent system supports are intact.
 - c) Inspect joints for signs of condensate or flue gas leakage.
 - d) Inspect venting components for corrosion or other deterioration. Replace any defective vent system components.
- 4) Service the oil burner:
 - a) Replace oil nozzle with identical make and model (see Table 11.1).
 - b) Inspect the electrodes. Replace if they are deteriorated. Make sure that the electrode position is set according to the burner manufacturer's instructions.
 - c) Remove and clean fuel pump strainer.
 - d) Remove any accumulations of dust, hair, etc. from the air shutter, blower wheel, and other air handling parts of the burner.
 - e) Replace the fuel oil line filter element and gaskets.
- 6) Inspect all oil piping and fittings for kinks and leaks. Repair any found.
- 7) Inspect the hydronic piping and boiler for water leaks. Repair any leaks found immediately.
- 8) Verify operation of relief valve by manually lifting lever; replace relief valve immediately if valve fails to relieve pressure.
- 9) Open fuel line shut-off valve(s) and restore electrical power to the boiler.
- 10) Fire the boiler and check it out using the procedure outlined in "Start-up and Checkout" . This must include checking the burner adjustments using instruments. Check for proper operation of all controls.



WARNING

Water leaks can cause severe corrosion damage to the boiler or other system components. Repair any leaks found immediately.

Important Product Safety Information **Refractory Ceramic Fiber Product**

Warning:

The Parts list designates parts that contain refractory ceramic fibers (RCF). RCF has been classified as a possible human carcinogen. When exposed to temperatures about 1805°F, such as during direct flame contact, RCF changes into crystalline silica, a known carcinogen. When disturbed as a result of servicing or repair, these substances become airborne and, if inhaled, may be hazardous to your health.

AVOID Breathing Fiber Particulates and Dust

Precautionary Measures:

Do not remove or replace RCF parts or attempt any service or repair work involving RCF without wearing the following protective gear:

1. A National Institute for Occupational Safety and Health (NIOSH) approved respirator
 2. Long sleeved, loose fitting clothing
 3. Gloves
 4. Eye Protection
- Take steps to assure adequate ventilation.
 - Wash all exposed body areas gently with soap and water after contact.
 - Wash work clothes separately from other laundry and rinse washing machine after use to avoid contaminating other clothes.
 - Discard used RCF components by sealing in an airtight plastic bag. RCF and crystalline silica are not classified as hazardous wastes in the United States and Canada.

First Aid Procedures:

- If contact with eyes: Flush with water for at least 15 minutes. Seek immediate medical attention if irritation persists.
- If contact with skin: Wash affected area gently with soap and water. Seek immediate medical attention if irritation persists.
- If breathing difficulty develops: Leave the area and move to a location with clean fresh air. Seek immediate medical attention if breathing difficulties persist.
- Ingestion: Do not induce vomiting. Drink plenty of water. Seek immediate medical attention.

XIV Trouble Shooting

A. Combustion

- 1) Nozzles - The selection of the nozzle supplied with the FWZ boiler is the result of extensive testing to obtain the best flame shape and efficient combustion. Other brands of the same spray angle and pattern may be used but may not perform at the expected level of CO₂ and smoke. Nozzles are delicate and should be protected from dirt and abuse. Nozzles are mass-produced and can vary from sample to sample. For all of those reasons a spare nozzle should be part of a serviceman's replacement parts inventory.
- 2) Flame Shape - As seen for the observation port, the flame should appear straight with no sparklers rolling up toward the crown of the chamber. If the flame drags to the right or left, sends sparklers upward or makes wet spots on the chamber walls, the nozzle should be replaced. If the condition persists look for fuel leaks, air leaks, water or dirt in the fuel as described below.
- 3) Fuel Leaks - Any fuel leak between the pump and the nozzle will be detrimental to good combustion results. Look for wet surfaces in the air tube, under the ignitor and around the air inlet. Any such leaks should be repaired as they may cause erratic burning of the fuel and in the extreme case may become a fire hazard.
- 4) Air Leaks - Any such leaks should be repaired as they may cause erratic burning of fuel and in extreme cases may become a fire hazard.
- 5) Gasket Leaks - If CO₂ readings between 11.5% and 12.8% with a #1 smoke cannot be obtained in the breeching, or if odors are observed, look for leaks around the burner mounting gasket, observation door and canopy gasket, or in the breeching below the point where the flue gas sample is taken. Air leakage into the boiler or breeching can cause low CO₂ readings (the lower the firing rate, the greater effect an air leak can have on CO₂ readings). Such leaks can also cause flue gas leakage into the building, resulting in odor complaints.
- 6) Dirt - The use of a fuel filter is good practice. Accidental accumulation of dirt in the fuel system can clog the nozzle or nozzle strainer and produce a poor spray pattern from the nozzle. The smaller the firing rate, the smaller the slots in the nozzle and the more prone to plugging it becomes.
- 7) Water - Water in the fuel in large amounts will stall the fuel pump. Water in the fuel in smaller amounts will cause excessive wear on the pump. More importantly it chills the flame and causes smoke and unburned fuel to pass through the combustion chamber and clog the flueways of the boiler.
- 8) Cold Oil - If the oil temperature near the fuel pump is 40°F or lower, poor combustion or delayed ignition may result. Cold oil is harder for the nozzle to atomize, thus the oil droplets get larger and travel further creating a longer flame. An outside fuel tank that is above grade or has fuel lines in a shallow bury is a good candidate for cold oil. The best solution is to bury the tank and lines deep enough to keep the oil above 40°F. Be sure to follow any state and local codes when burying fuel oil tanks and/or fuel oil lines.
- 9) Start-Up Noise - Delayed ignition is the cause of start-up noises. If it occurs recheck for electrode settings, flame shape, air or water in the fuel lines.
- 10) Shut Down Noise - If the flame runs out of air before it runs out of fuel, an after burn with noise may occur. That may be the result of a faulty cut-off valve in the fuel pump, or it may be air trapped in the nozzle line. It may take several firing cycles for that air to be fully vented through the nozzle. Water in the fuel or poor flame shape can also cause shut down noises.

TEST PROCEDURE FOR FUEL SIDE PROBLEMS

A good test for isolating fuel side problems is to disconnect the fuel system and with a 24" length of tubing, fire the burner out of an auxiliary five gallon pail of clean, fresh, warm #2 fuel oil from another source. If the burner runs successfully when drawing out of the auxiliary pail then the problem is isolated to the fuel or fuel lines being used on the installation.

B. Control System

The following pages contain a trouble shooting table and flow charts for use in diagnosing control problems. When using these materials the following should be kept in mind:

- 1) This information is only meant to be used by a professional heating technician as an aid in diagnosing boiler problems.
- 2) Where applicable, follow all precautions outlined in the Section XI (Start-up and Checkout).
- 3) In general, this table and flow charts assume that there are no loose or miswired electrical connections. Before using these tables inspect all electrical connections on the boiler to make sure that they are tight. Also, check the wiring on the boiler against the wiring diagram in Figures 10.0 and 10.1. Ensure that incoming 120 VAC power polarity is correct and that the boiler is properly grounded.
- 4) All controls on the boiler are tested at least once in the manufacturing process and a defective control or component is generally the least likely cause. Before replacing a component, try to rule out all other possible causes.

TABLE 14.0 - DIAGNOSTIC CONDITIONS

Condition	Possible Cause
Burner will not fire	See Flow Chart 1, page 46
Burner will not shut down	See Flow Chart 2, page 47
Temperature display exceeds high limit setting	Under normal operation, boiler temperature will continue to rise after the control shuts off the burner. This condition, known as “thermal stacking”, results from hot boiler surfaces continuing to release heat into the boiler water.
No or insufficient domestic hot water	For boilers equipped with a tankless coil, make sure the low limit setting on the control is set properly. NOTE: If the low limit setting is dialed fully counterclockwise, it will shut off the low temperature maintenance feature and will function as a cold start control. If installed with an indirect water heater, check that the Zone/Indirect Switch is set in the Indirect (I) position. Verify that the end switch in the relay box controlling the indirect water heater is connected to the ZC-ZR terminals. This will ensure that the domestic water calls are prioritized.
Low water light (Red LED) is on or blinking	 <p>WARNING: A low water condition is a serious and potentially dangerous condition. Do not attempt to add water to a hot boiler. Allow the boiler to fully cool before adding water.</p> <p>When the LOW WATER light is on, this indicates that the control is not detecting water in the boiler. When the LOW WATER light is blinking, this indicates that the control has been programmed to provide low water lock-out protection and is currently locked out (see Manual Reset Low Water Cut-Off). Pressing the TEST/SETTINGS button after the low water condition is resolved will reset the lock-out condition.</p> <ol style="list-style-type: none"> 1. If the light is on and the heating system is filled with water, pull the sensor out of the well and inspect it. Make sure that the metal clip is protruding enough to come in contact with the inside of the well tube. Check that the well does not have excessive build-up of heat transfer grease that may interfere with the clip contacting the well. 2. Remove well and examine for excessive residue build-up. Clean and re-install.
House will not get or stay warm	<ol style="list-style-type: none"> 1. Check for air-bound radiators. 2. Check thermostat settings including heat anticipator settings (common on non-digital thermostats). 3. Check the Economy setting. The Economy feature, much like outdoor reset controls, lowers average boiler temperature and can slow or, in some cases, prevent the house from coming up to temperature. Move to a lower setting (see “Setting the Economy Feature”).
Circulator contacts C1 and C2 not energized on call for heat	Check to see that boiler water is at or above 125°F. On a call for heat, the control will not permit the circulator to operate if the boiler water temperature is below 125°F (see “Circulator Hold Off”).
All LED lights and temp display are blinking	If the LED lights and the temp display are blinking alternately, this indicates the control has sensed a boiler temperature of 250°F. When this occurs, the control pulses the burner relay and then shuts down and locks-out the burner. The system should be analyzed to determine the cause of the overheating condition. Check that the sensor is inserted all the way into the well so it can accurately sense the temperature of the boiler water. Check the load on the burner contacts: If the load exceeds the 7.4 Amp rating, the contacts may have welded. Correct the overloading condition and replace the control before reenergizing the system. If the load on the contacts is below the rating, check system wiring and operation as well as the control’s high limit setting. If the cause of the overheating is found and the system is deemed safe, the control can be reset by removing power from the control and then reenergizing while simultaneously pressing the Test/Settings button on the top of the control. If the cause of the overheating condition is not determined, the control should be replaced.

Troubleshooting Flow Chart 1 – Burner Will Not Fire

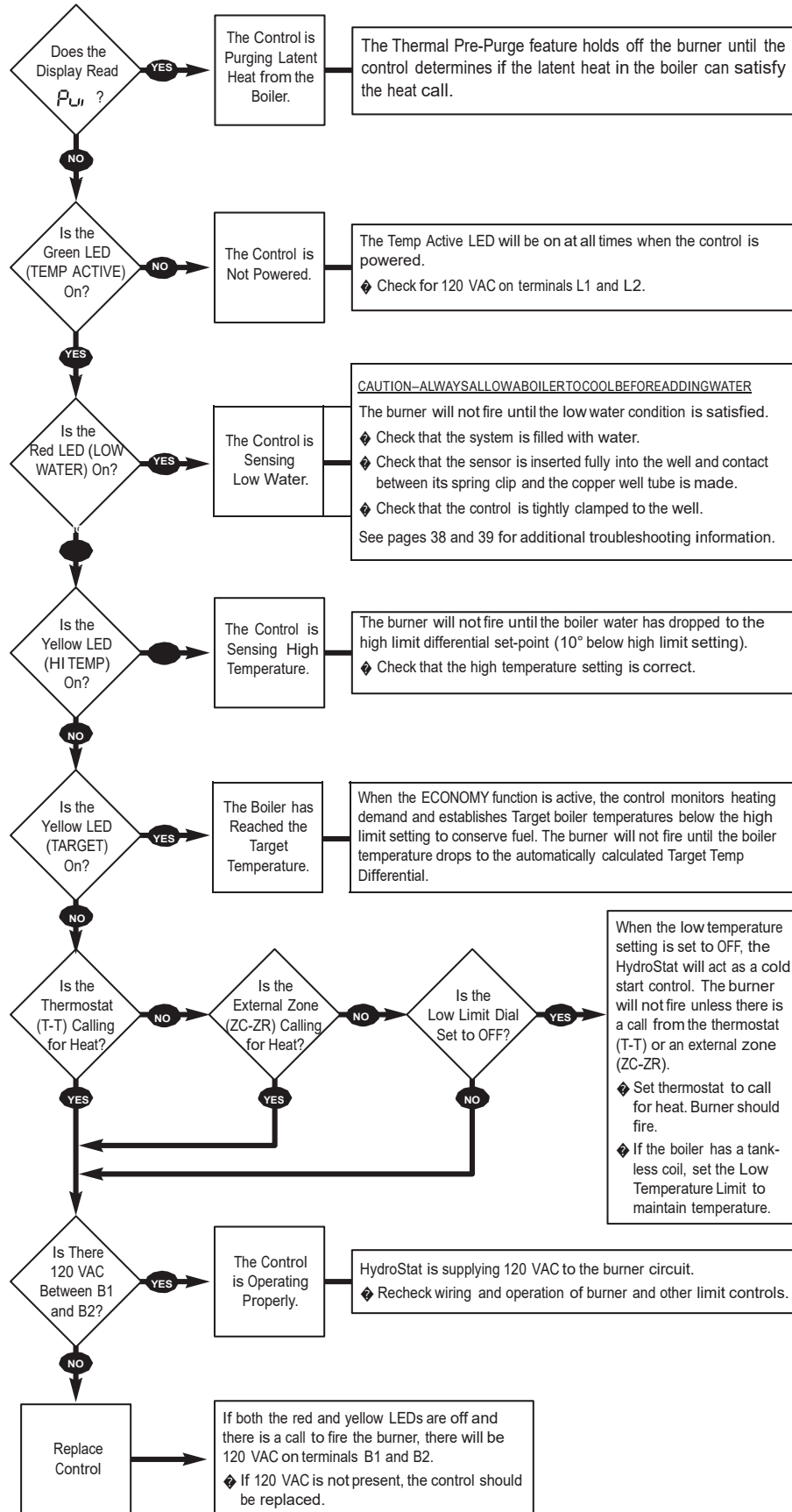

Troubleshooting Flow Chart 2 – Burner Will Not Shut Down

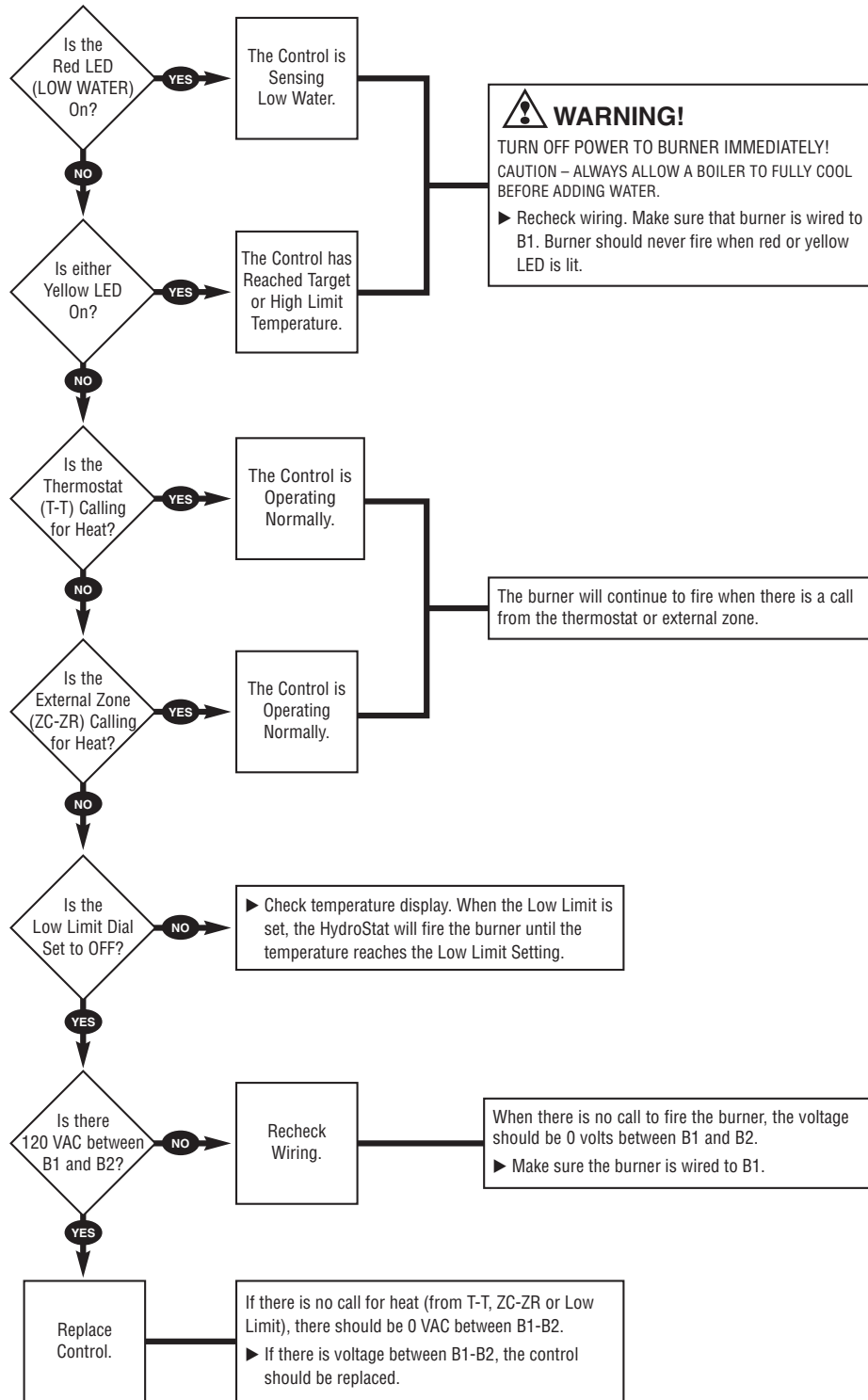

XV Parts

KEY #	DESCRIPTION	QTY. OR CROWN PN	QUANTITY PER BOILER OR CROWN PART NUMBER					
			FWZ060	FWZ080	FWZ081	FWZ100	FWZ130	FWZ160
1	HEAT EXCHANGER ASSEMBLY	1	410012	410012	410013	410013	410014	410015
2	SPANNER BAR	2	410402	410402	410403	410403	410404	410405
3	NYLON GLIDE	700111	4	4	4	4	4	4
4	HEX HD CAP SCREW 5/16-18 X 7/8"	900109	10	10	10	10	10	10
5	FLAT WASHER 5/16"	900102	13	13	13	13	13	13
6	HEX JAM NUT 5/16-18	900103	4	4	4	4	4	4
7	HINGE BRACKET	410010	1	1	1	1	1	1
8	HEX HD CAP SCREW 5/16-18 X 7/8"	900109	2	2	2	2	2	2
9	SWING DOOR	410020	1	1	1	1	1	1
10	SWING DOOR INSULATION LESS POCKETS	410021	1	1	1	1	1	
10	SWING DOOR INSULATION WITH POCKETS	410023						1
11	1/2" DIA ROPE GASKET - SWING DOOR	410024	1	1	1	1	1	1
12	1/8" DIA ROPE GASKET - OBSERVATION PORT	410032	1	1	1	1	1	1
13	OBSERVATION PORT COVER	410022	1	1	1	1	1	1
14	SOCKET HD CAP SCREW 5/16"-18 X 3/4"	900108	2	2	2	2	2	2
15	HEX HD TAP BOLT 3/8"-16 X 1-3/4"	900170	2	2	2	2	2	2
16	FLAT WASHER 3/8"	90-036	2	2	2	2	2	2
17	SMOKEBOX	410006	1	1	1	1	1	1
18	BRASS SQUARE HD PIPE PLUG 1/4" NPT	950041	1	1	1	1	1	1
19	SMOKEBOX COLLAR - 5" DIA.	410025	1	1				
19	SMOKEBOX COLLAR - 6" DIA.	410026			1	1	1	
19	SMOKEBOX COLLAR - 7" DIA.	410027						1
20	CLEAN OUT COVER	410004	2	2	2	2	2	2
21	1/2" DIA ROPE GASKET - CLEAN OUT COVER	410005	EA	EA	EA	EA	EA	EA
22	THIRD PASS BAFFLE *	410007	2	2	2	2*	2*	2*
23	SECOND PASS BAFFLE - 080	410009		2				
24	SECOND PASS BAFFLE - 100/130/160	410008				2	2	2
25	REFRACTORY BLANKET *	1	NA	NA	415003	415003*	415004*	415005*

* Not used in all applications - consult Table 4.1

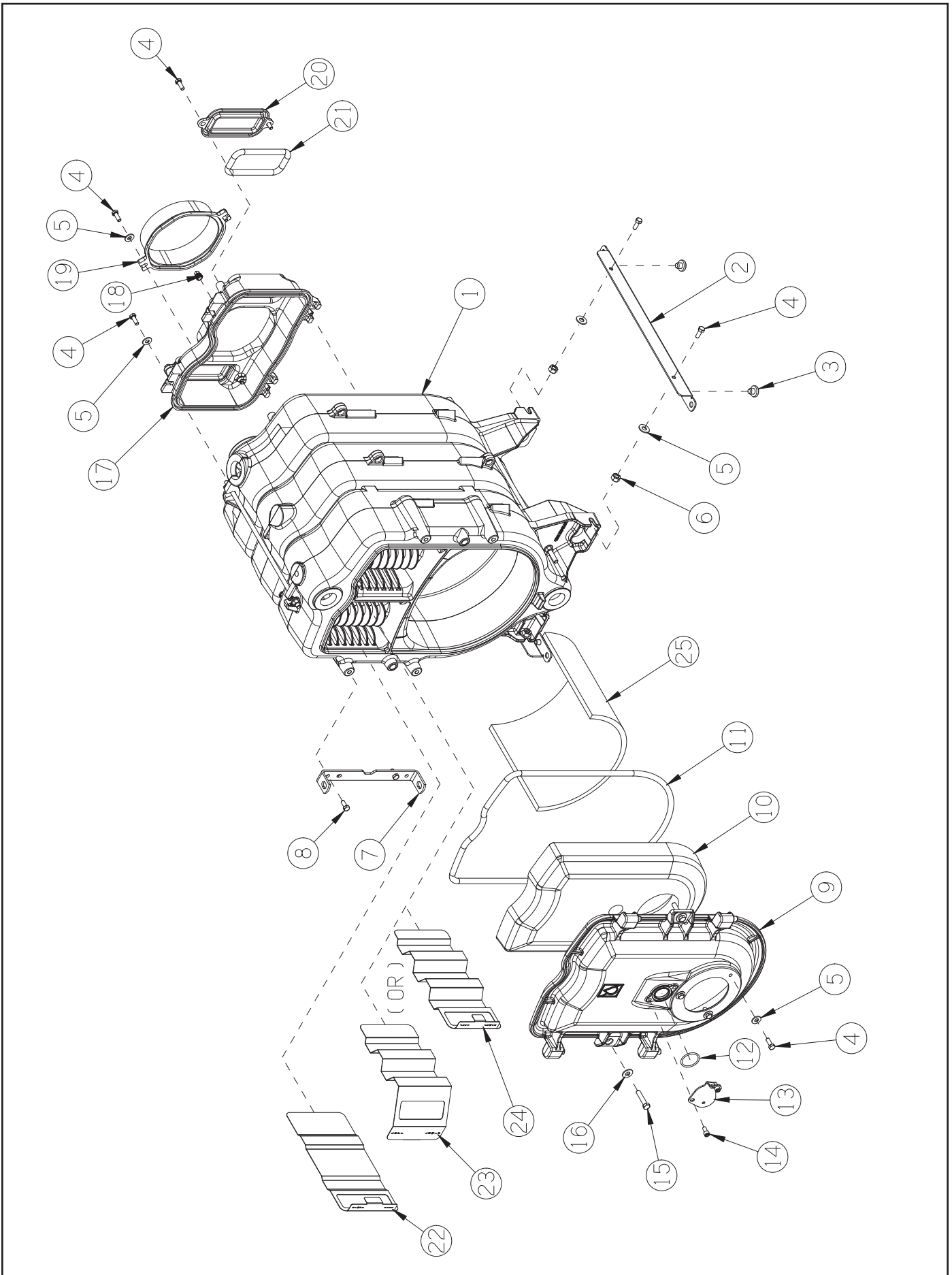

KEY #	DESCRIPTION	QTY. OR CROWN PN	QUANTITY PER BOILER OR CROWN PART NUMBER					
			FWZ060	FWZ080	FWZ081	FWZ100	FWZ130	FWZ160
30	FRONT JACKET PANEL	410310	1	1	1	1	1	1
31	RIGHT SIDE JACKET PANEL	1	410302	410302	410303	410303	410304	410305
32	LEFT SIDE JACKET PANEL	1	410312	410312	410313	410313	410314	410315
33	REAR JACKET PANEL	410301	1	1	1	1	1	1
34	TOP JACKET PANEL	1	410322	410322	410323	410323	410324	410325
35	FIBERGLASS INSULATION WRAPPER	1	412302	412302	412303	412303	412304	412305
36	POWER RECEPTACLE	960041	1	1	1	1	1	1
37	CROWN NAMEPLATE	98-004	1	1	1	1	1	1
38	#10 X 1/2" SHEET METAL SCREW	900120	15	15	15	15	15	15
39	5/16"-18 X 1/2" PAN HEAD SCREW	900420	4	4	4	4	4	4
40	5/16"-18 X 3" THREADED STUD	900111	2	2	2	2	2	2
41	5/8"O.D. X 2-5/32" LONG JACKET SPACER	410200	2	2	2	2	2	2
42	5/16"-18 ACORN NUT	146-95-042	2	2	2	2	2	2
43	RECEPTACLE ENCLOSURE	410090	1	1	1	1	1	1

* NOT SHOWN

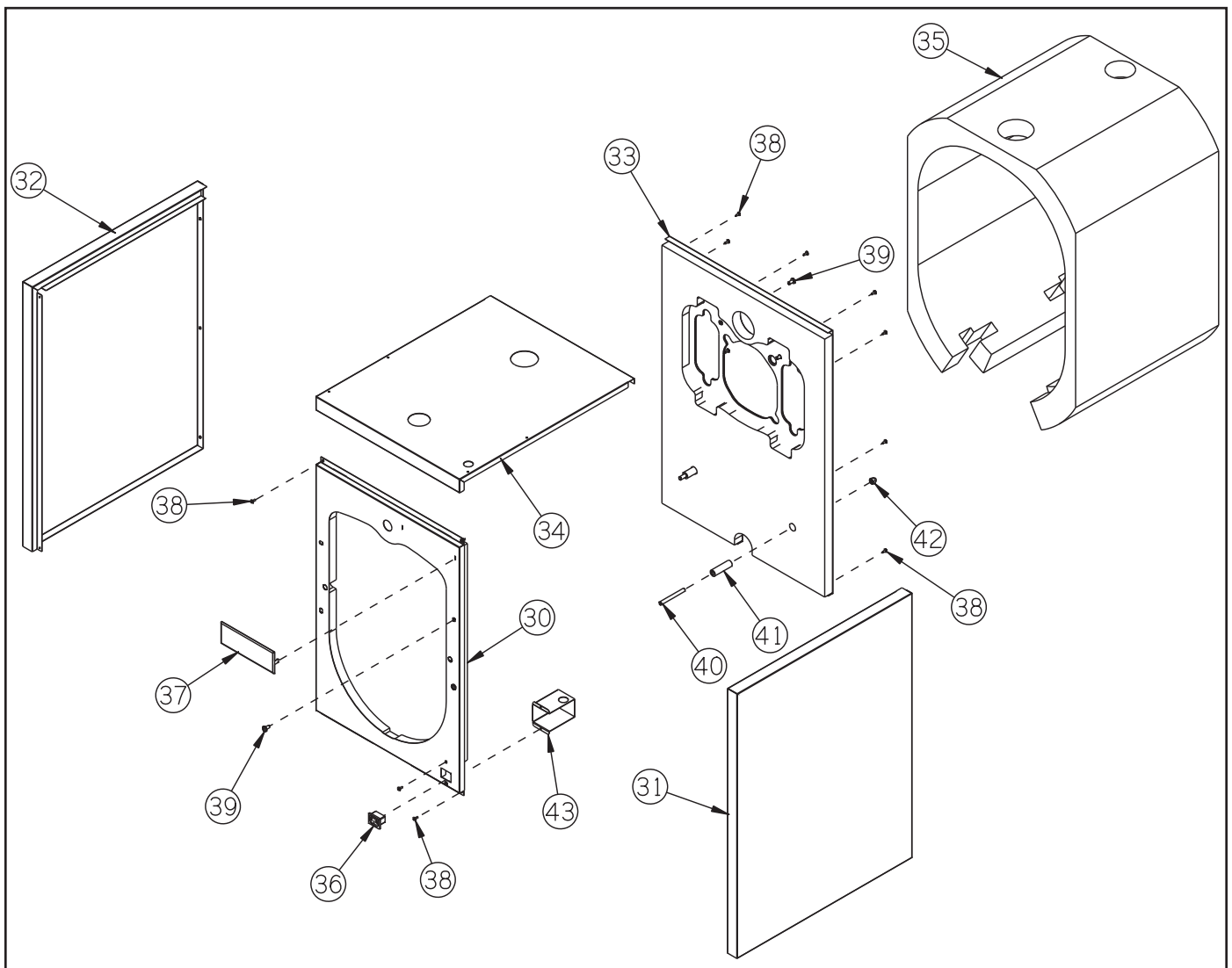

KEY #	DESCRIPTION	QTY. OR CROWN PN	QUANTITY PER BOILER OR CROWN PART NUMBER					
			FWZ060	FWZ080	FWZ081	FWZ100	FWZ130	FWZ160
50	BECKETT OIL BURNER ASSY ¹	1	41060B	41080B	41081B	41100B	41130B	41160B
50	RIELLO OIL BURNER ASSY ¹	1			41081R	41100R	41130R	41160R
50	CARLIN OIL BURNER ASSY ¹	1			41081C	41100C	41130C	41160C
51	TEMPERATURE & PRESSURE GAUGE	950039	1	1	1	1	1	1
52	HYDROLEVEL 48-222 ELECTROWELL	450354	1	1	1	1	1	1
53	HYDROSTAT 3250 PLUS	450352	1	1	1	1	1	1
54	2" NPT RETURN INJECTOR PIPE	410050	1	1	1	1	1	1
55	2" X 1-1/2" NPT REDUCING ELBOW	950036	1	1	1	1	1	1
56	1-1/2" NPT X 3" NIPPLE	950023	1	1	1	1	1	1
57	1-1/4" NPT X 4" NIPPLE	95-033	1	1	1	1	1	1
58	1-1/4" X 3/4" REDUCING COUPLING	950117	1	1	1	1	1	1
59	3/4" NPT DRAIN VALVE	95-041	1	1	1	1	1	1
61	1-1/2" NPT X 8" NIPPLE	950028	1	1	1	1	1	1
62	1-1/2" NPT CROSS	950029	1	1	1	1	1	1
63	1-1/2" NPT PLUG	95-143	1	1	1	1	1	1
64	1-1/2" X 3/4" BUSHING	95-096	1	1	1	1	1	1
65	3/4" NPT X CLOSE NIPPLE	95-105	2	2	2	2	2	2
66	3/4" NPT 90° ELBOW	95-057	1	1	1	1	1	1
67	3/4" NPT RELIEF VALVE (30 PSI)	95-040	1	1	1	1	1	1
68	BURNER TUBE INSULATION	415001	SEE TABLE 4.1 FOR WHERE USED					
*	BAROMETRIC DRAFT CONTROL	1	130022	130022	13-020	13-020	13-020	13-018
*	CIRCULATOR (TACO 007)	95-012	1	1	1	1	1	1
*	1-1/2" NPT TACO FLANGE SET	950150	1	1	1	1	1	1
*	FWZ STANDARD WIRING HARNESS	9601903	1	1	1	1	1	1

* NOT SHOWN

1. PART NUMBERS PROVIDED ARE FOR FULLY CONFIGURED BURNERS AND INCLUDE PRIMARY SAFETY CONTROL, NOZZLES, BURNER CORD ASSEMBLIES AND (WHERE APPLICABLE) LOW FIRING RATE BAFFLES. SOME BURNERS ARE ALSO SUPPLIED WITH BLANKETS AND BAFFLES. SEE TABLE 4.1 FOR DETAILS.

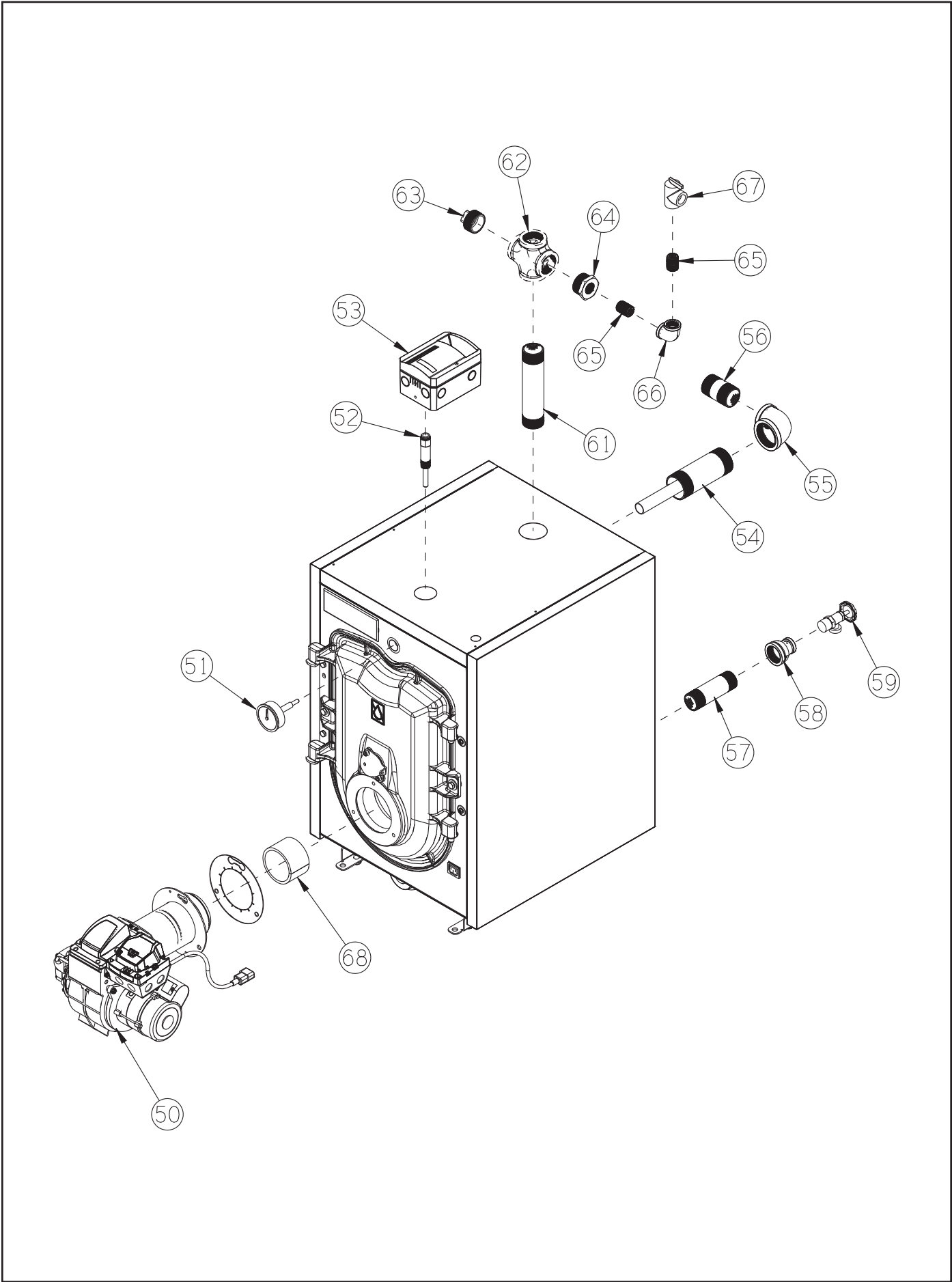



Manufacturer of Hydronic Heating Products
P.O. Box 14818 3633 I. Street
Philadelphia, PA 19134
www.crownboiler.com