

# TEDDY W5A

US

## OPERATING INSTRUCTIONS



## EXPLODED VIEW

No.....	Description.....	Part No.
1.....	Control button, left and right .....	AR005-178-TZ005
2.....	Base .....	AR005-022-TZ002
2.1.....	Fuse 5 A, slow, 110V .....	AR005-418-00001
3.....	Cover plate .....	AR005-347-TZ001
4.....	Cable with Rheostat and microswitches.....	AR005-193-TZ001
5.....	Tilt Bearing, left and right .....	AR005-337-TZ001
6.....	Lid.....	AR005-024-TZ002
7.....	Intermediate shaft.....	AR005-325-TZ001
8.....	Upperpart .....	AR005-023-TZ002
9.....	Lockpin .....	AR005-332-TZ001
10.....	Planetary Head.....	AR005-002-TS001
11.....	Control board.....	AR005-378-TS001
12.....	Transformer 115V.....	AR005-368-TZ001
13.....	Motor .....	AR005-339-TZ001
13.1....	Poly-V belt .....	AR005-090-TD001
14.....	Release housing.....	AR005-372-TS001
15.....	Weight Compensator.....	AR005-352-TZ001
16.....	Attachment drive .....	AR005-010-TZ001
17.....	Machine feet.....	AR005-213-TZ001
18.....	Fixing of bowl .....	AR005-340-TZ001
19.....	Power Cable .....	AR005-194-TD006
20.....	Receptacle male.....	STA 7210
21.....	Torx Screw for Tilt Bearing .....	STA 5700
22.....	Microswitch.....	30E-508
23.....	Bolt, Top Lid.....	AR005-344-TS001
24.....	Pin, Tilt Bearing .....	STA 6000

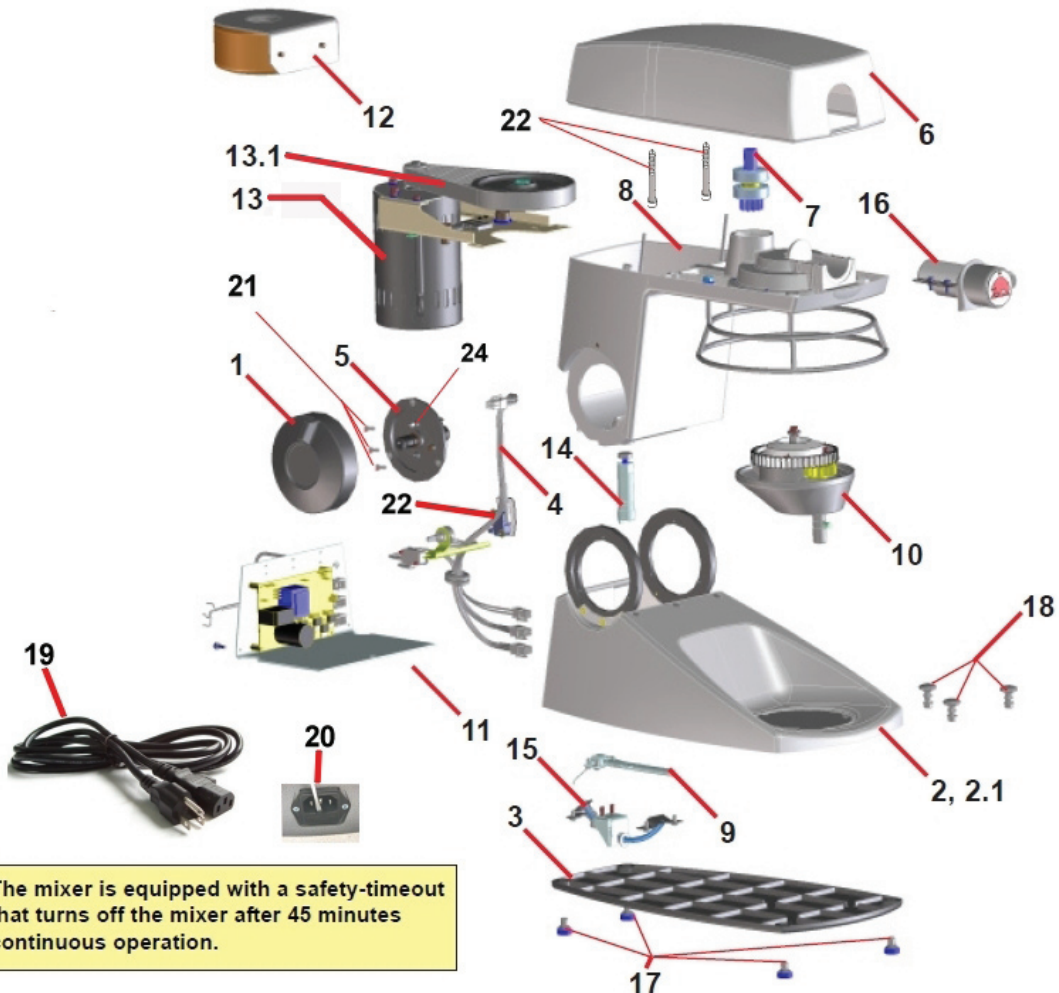

# OPERATING INSTRUCTIONS

## TEDDY™ W5A Food Mixer

### with Attachment Drive

**CONTENTS:**

**GUARANTEE:**..... 1

**SAFETY:** ..... 1

**INSTALLATION OF NEW MIXER:** ..... 1

**CONNECTION TO POWER:**..... 2

**INTRODUCTION TO THE MIXER:** ..... 2

**RECOMMENDED WORKING SPEEDS:**..... 2

**OPERATION OF THE MIXER:** ..... 3

**MAXIMUM CAPACITY OF THE MIXER:**..... 3

**OVERLOAD:** ..... 3

**CLEANING AND HYGIENE:**..... 3

**MAINTENANCE:**..... 4

**LIST OF ERRORS AND POSSIBLE SOLUTIONS:** ..... 4

**MOUNTING OF ACCESSORIES:** ..... 4

**RECOMMENDED SPEEDS FOR ATTACHMENT DRIVE:**..... 4

**GUARANTEE:**

The guarantee does not cover faults resulting from faulty operation, overloading and lacking observance of directions of maintenance.

In case of complaints, please contact your dealer.

In case you want further information, please state machine type and serial number of the mixer.

**SAFETY:**

The safety of the user is achieved by:

- The mixer will only start when the upper part is lowered.
- The upper part can only be tilted up when the mixer is stopped.
- Protection from excess current, excess voltage and too low voltage.
- The mixer is provided with fixed bowl screen.

**INSTALLATION OF NEW MIXER:**

The following equipment is included:

- ✓ Cable
- ✓ Beater
- ✓ Ingredient chute
- ✓ Hook
- ✓ Whip
- ✓ Bowl
- ✓ Lid for the bowl

Before taking the mixer into use, check that all parts are delivered.

**Dimensions and weight:**

TEDDY inclusive equipment:

- Net weight with equipment: 44 Lbs.
- Outside dimensions of mixer: 18 ¼ " x 9 ½ " x 15 ¾ "

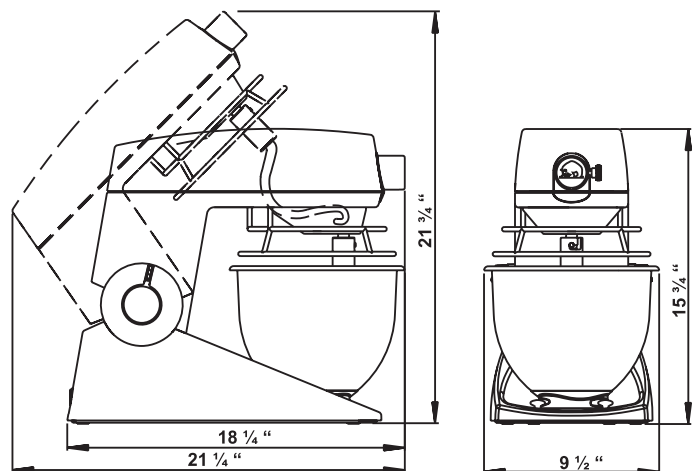

**Location:**

The mixer is to be placed on a stable and horizontal table.

**The mixer is designed for manufacture of products which do not during processing cause reactions or emit substances which may be detrimental to the user.**

**Putting your fingers in the bowl while the mixer is running may cause injuries.**

The mixer is listed by:



14240 South Lakes Drive  
 Charlotte, NC 28273  
 800 222-1138  
 www.varimixer.com  
 varimixer@varimixer.com

## CONNECTION TO POWER:



**The enclosed cable must be used.**

**The mixer must be connected to ground!**

- Only single phase power supply with ground must be used for the mixer. Use the enclosed cable.
- A plug with 2 pins + ground must be used.
- Check that the voltage of the power supply corresponds the voltage printed on the rating plate placed in the bottom of the mixer and stated on the packing.
- The mixer must be protected by a differential circuit breaker and a fuse of max. 10 A.  
A fuse is built into the cable plug.

### The power characteristics of the mixer:

Supply voltage (V)	Output (W)	Frequency (Hz)	Voltage (A)	Motor Power (HP)
115	300	60	3	0.4

## INTRODUCTION TO THE MIXER:

**TEDDY** is a small professional mixer for kneading, mixing and whipping in bakeries, confectioneries or kitchens.

Any operation of the mixer is made by means of the rotary knobs on the sides of the mixer. The two knobs can be used simultaneously or individually and are used both for speed regulation and as opening/closing function.

The attachment hub **A** makes it possible to connect meat grinder and vegetable slicer.

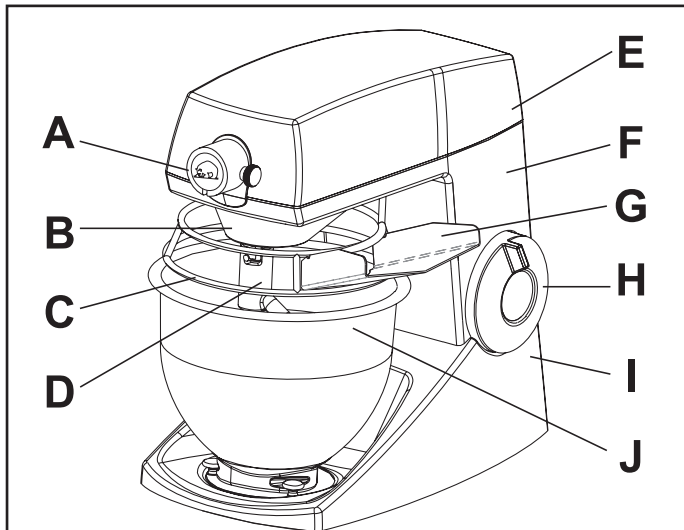

Fig. 1 The construction of the mixer

A	Attachment hub
B	Housing of the planetary gear
C	Bowl screen in stainless steel
D	Bayonet shaft
E	Lid
F	Upper part
G	Ingredient chute
H	Rotary knobs (two pcs.)
I	Base
J	Bowl in stainless steel, contents 5 quarts

## Equipment:

As standard the mixer comes with the following equipment:

- Bowl in stainless steel.
- White plastic lid for bowl (lids in various colors are available).
- Ingredient chute.
- Dough hook in stainless steel for kneading of dough.
- Beater in stainless steel for mixing.
- Whip in stainless steel for whipping.

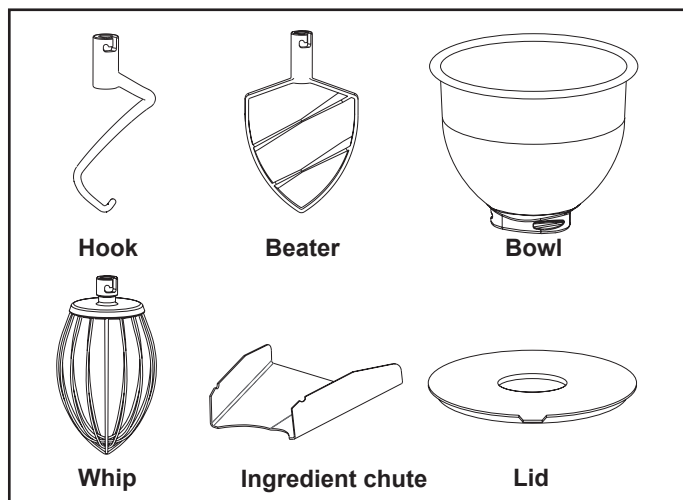

## Extra equipment:

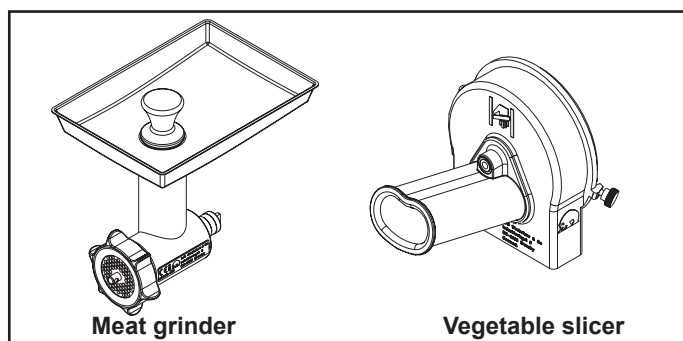

## RECOMMENDED WORKING SPEEDS:

- Position 1-2: Low speed Kneading
- Position 1-3: Medium speed Mixing
- Position 1-5: High speed Whipping

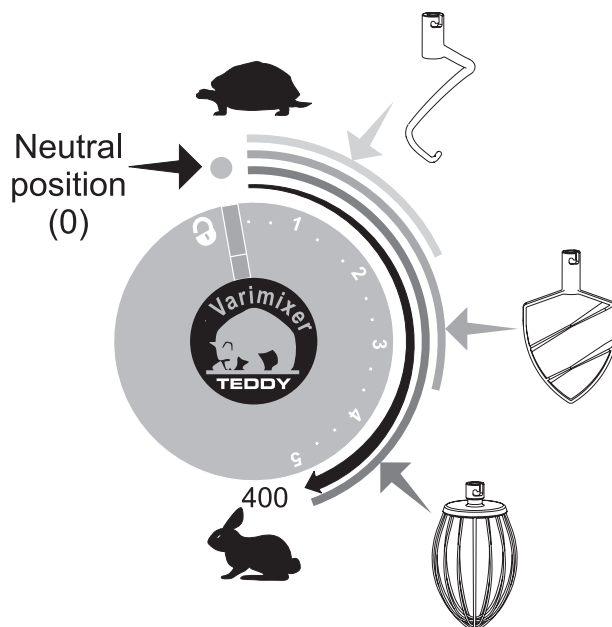

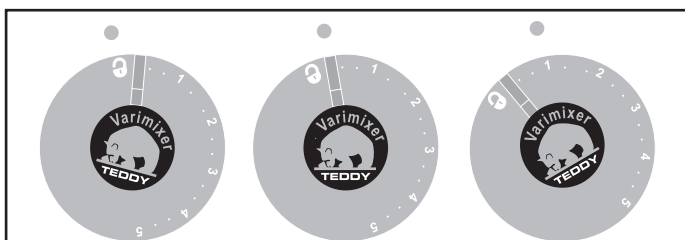

Fig. 2 Recommended working speeds

## OPERATION OF THE MIXER:

 **The bowl must be mounted when the mixer is started!**

A. Turn the rotary knobs to the locking symbol (fig. 3A).



A: Locking symbol B: Neutral position C: Speeds  
Fig.3 The three positions of the rotary knobs.

B. Tilt backwards the upper part of the mixer.

C. Place a tool in the bayonet shaft and turn it counter-clockwise to lock it in position (fig. 4).

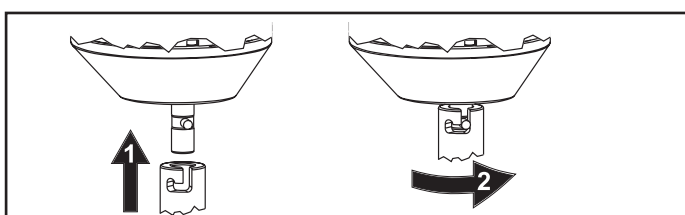

Fig. 4 Mounting of tool in the bayonet shaft.

D. Place the bowl between the three locking bolts in the foot of the mixer and turn it clockwise until locked (fig. 5).

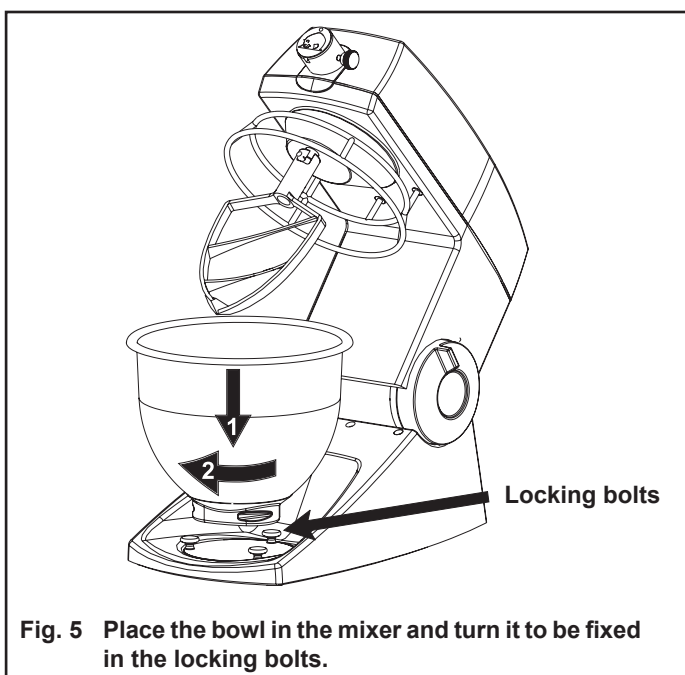

Fig. 5 Place the bowl in the mixer and turn it to be fixed in the locking bolts.

E. Fill the ingredients in the bowl.

F. Tilt the upper part of the mixer, including tool, down.

G. Start the mixer by turning the rotary knobs away from the locking symbol and past 1. To avoid splashing and dust from flour, it is recommended to increase the speed gradually until the required speed is obtained (fig. 3C), (see fig. 2 for recommended working speeds).

H. Stop the mixer by turning the rotary knobs back to neutral position (fig. 3B).

I. The upper part of the mixer can only be tilted backwards when the rotary knobs is turned to the locking symbol (fig. 3A).

3

## MAXIMUM CAPACITY OF THE MIXER:

The working capacity of the mixer depends of:

- The tool used.
- Sort and quantity of the raw materials.
- The optimum speed for a good result.

 **Too big quantities will always reduce the quality of the product and the life of the mixer. Overloading can also result in sudden stops.**

Product	Raw material	Approx. max. quantity
Bread dough, 50%	Lbs	5
Mashed potatoes	Lbs	4
Whipped cream	Qt	1
Layer cake	Lbs	6
Cake donuts	Lbs	6

## OVERLOADING:

If the mixer is moving e.g. kneading dough, this is **not** due to errors or overloading.

In case of overloading the electronic variator will reduce the current to the motor and stop it.

 **In case of stop due to overloading, turn the rotary button back to neutral position, and the mixer can be started again.**

If the motor stops after long time of operation, and cannot be started immediately after, the thermosensor of the motor has switched off the current, and the mixer needs to cool down before it can be re-started. This protects the motor from overheating.

The mixer contains two thermal cut-outs, which automatically reconnect in case of previous disconnection by the thermosensor.

## CLEANING AND HYGIENE:

After use:

- Remove bowl and tools.
- Wash the bowl and the tools in hot water and detergent / degreaser / disinfectant. Rinse with pure water and dry.

 **Do not spray water on the mixer**

**Tools and bowl can be cleaned in dishwasher.**

- Wipe the housing of the planetary gear, the bayonet shaft and the bowl screen. Use a damp sponge and a detergent / disinfectant. Rinse the parts with sponge and pure water.
- Check that the various parts have been cleaned thoroughly.
- Do not use abrasive detergents, which could scratch the surface.
- Use detergents suited for use on aluminium and plastic (polycarbonate).

## MAINTENANCE:

The mixer requires no maintenance (motor and bearings for the mechanical parts are greased for life).

### Safety device:

Check the function of the safety device regularly:

- The motor **must** stop when the rotary knobs is in neutral position (see fig. 3B).



**If the safety device does not function, do not use the mixer. Contact your dealer.**

## LIST OF ERRORS AND POSSIBLE SOLUTIONS:



**If the problem cannot be solved, contact your dealer.**

### The mixer does not start:

Check that ...

- The upper part of the mixer is in its down position.
- The mixer is plugged in and connected to power.
- The electrical power supply is correct.
- The fuse in the cable plug (fig.6, 1) has not been burned. If the fuse is defective, it can be replaced by the extra fuse (fig.6, 2) that is also available in the cable plug.

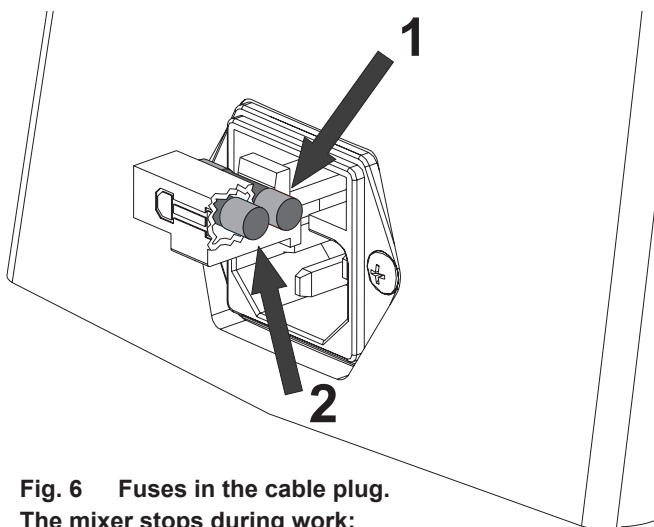

Fig. 6 Fuses in the cable plug.

### The mixer stops during work:

- The mixer is overloaded due to too high speed or too heavy loading. See the paragraph "Overloading".



**In case of power failure set the rotary button back to neutral position, and the mixer can be started again.**

### The tool is stuck in the bayonet shaft:

This is normally due to insufficient cleaning or damaged hole in the tool:

- When the tool is stuck, do not force it free. Apply a little oil and let this work a couple of minutes.
- Turn the tool backwards and forwards until it can be removed.

### Unnormal noise:

Metallic noise ...

- The tool is distorted and hits the bowl.
- The bowl has been damaged or is not in its proper position.

## MOUNTING OF ACCESSORIES:

The mixer is equipped with an attachment hub with variable speed, and with the possibility of attaching the following equipment:

- Meat grinder, supplied with meat tray, stomper and set of knives consisting of blade and plate 5/32".
- Vegetable slicer mounted with discs for shredding, grating and cube cutting.



**For further information regarding accessories, please see the special sheets following the accessories. The mixer must always be disconnected before mounting or dismantling of the accessory.**

### Mounting of accessories (fig. 7):

- Assemble the accessory in question.
- Stop the mixer.
- Turn the cover plate C away from the hole.
- When mounting the pre-mounted accessory A, the shaft B is inserted into the attachment drive D of the mixer.
- By turning the accessory until the pin E is pointing towards the slot G a correct clutch is obtained.
- The accessory is pushed as far into the attachment hub D as possible. (The pin E must be in the slot G, then the shaft of the accessory is in a correct clutch with the attachment drive).
- The accessory is fastened by turning the knob H clockwise.

### Dismantling of accessories (fig. 7):

- Stop the mixer.
- Turn the knob H counterclockwise until the locking screw is free of the hole F.
- Take out the accessory of the attachment hub, dismantle and clean it.

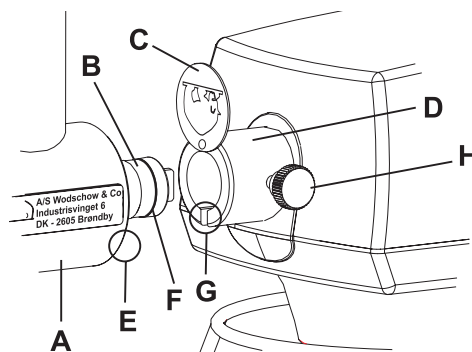
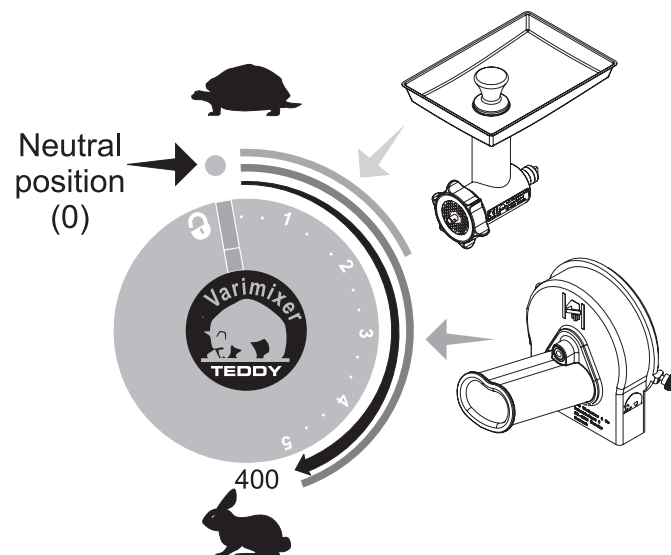
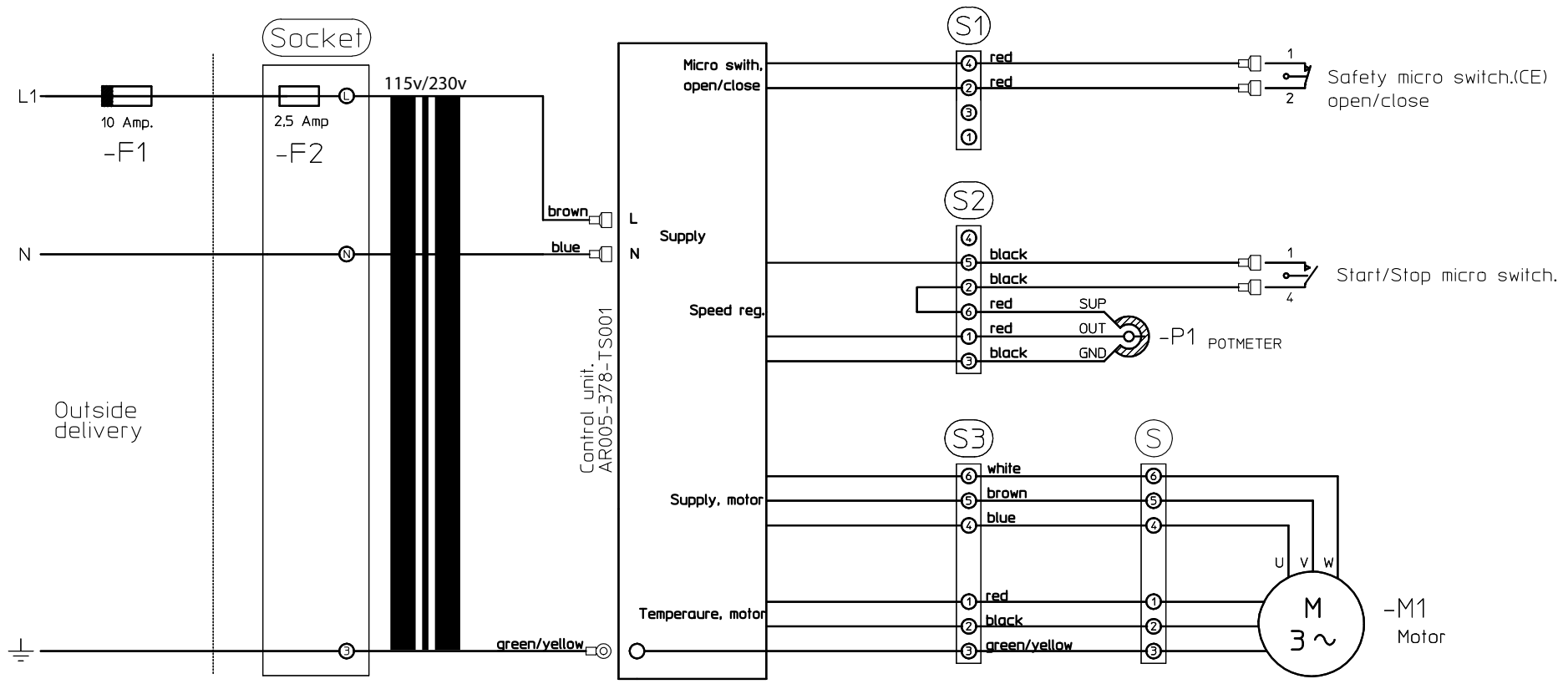

Fig. 7 Mounting of accessories.

## RECOMMENDED SPEEDS FOR ATTACHMENT HUB:







***Varimixer***

14240 South Lakes Drive  
Charlotte, NC 28273  
800 222-1138  
[www.varimixer.com](http://www.varimixer.com)  
[mixer@varimixer.com](mailto:mixer@varimixer.com)