

USER GUIDE

VACMASTER®

VP95

CHAMBER VACUUM SEALER



Welcome

The **VacMaster® VP95 Chamber Vacuum Sealer** is an ideal machine for home users like hunters, anglers, and foodies. It can also be a great addition for chefs in restaurants, catering, food trucks, and private chefs with its manual cycle to customize vacuum by percentage. With a streamlined, lightweight design and small footprint, the VP95 takes up less counter space making it easy to store away in the pantry or transport to an event. With its removable internal incline plate, the VP95 can handle almost anything, including liquids for marinating or sealing, like a champ. Features an easy to use touch screen control panel and is a reliable machine that will take your vacuum packaging experience to a whole new level.

For your safety and protection, carefully read and follow this guide. For more information, to Register your product or get support please visit us at VacMasterFresh.com

Contents

Add Oil	3
Features	4
Set Up	5
Control Panel	6
How to Use.....	7
How to Use Marinate Feature.....	8
Machine Maintenance.....	9
Important Tips.....	10
Cleaning and Storage	11
Troubleshooting	12
Important Guidelines	13
More Resources	14
Parts	15
Specs	18
Warranty and Registration.....	19



YOU MUST ADD OIL BEFORE USE!

FAILURE TO DO SO WILL DAMAGE THE PUMP!

VacMaster® VP95 uses an oil vacuum pump.
For shipping purposes there is no oil in the pump.

OIL MUST BE ADDED BEFORE USE!

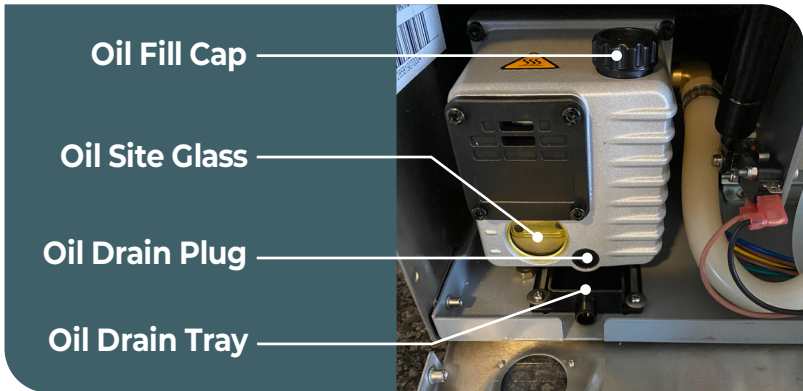

Adding Oil to Vacuum Pump

Turn off and unplug machine to prevent electrocution.

1. Using VacMaster® approved 10W non-detergent hydraulic oil.
2. Open the back cover by removing Phillips head screws located on the side of machine at the back - two on each side of case.
3. Locate the **OIL FILL CAP**.
4. Unscrew oil fill cap by hand.
5. Watching **OIL SITE GLASS**, pour oil into the oil fill hole.
6. Fill oil level between 1/2 to 3/4 of site glass.
7. Do not overfill. Overfilling can cause damage to the vacuum pump.
8. Replace and tighten **OIL FILL CAP**.
9. Replace the back cover.

VP95 Features



1. Heavy Duty Transparent Lid

2. Seal Pad

3. Lid Gasket

4. Vacuum Chamber

5. Accessory Port

6. Inclined Incline Plate: Used to occupy space in the chamber allowing for faster vacuum. When more space is filled, less air needs to be removed.

7. Seal Bar

8. Control Panel

On/Off Button

Start Button

Seal Button

Oil Clean Cycle

Marinate Button

Seal Time Button

Pulse Button

Manual Vacuum Percentage Control

Set Up - Powering up the VP95

1. Plug the power cord into the back of the machine and into the wall outlet.
2. Turn the power switch on - the switch is located on the back of the machine below the cord.
3. Machine is now powered up.



1. Fill the pouch and place inside the chamber

Fill the pouch with the product to be vacuum packaged and place the pouch inside the chamber. Keep pouches that contain liquids or wet product below the height of the seal bar. Lay the pouch flat inside the chamber, with the opening of the pouch across the seal bar. Make sure that the pouch lies flat across the seal bar and is free of wrinkles.

Note: The entire pouch, including the opening, must remain inside the chamber.

2. Start the vacuum sealing process

Close the lid and press the Start button to begin the vacuum cycle.

3. End of Cycle - When air returns to the chamber, gently lift the lid in the upright position.**4. Inspect the pouch**

When the lid opens, remove and inspect the pouch.

Vacuum confirmation - Check the quality of the vacuum by looking at the tightness of the pouch and the product. Look for air pockets or air leaks. If you notice that the product is not vacuum packaged tightly, then increase the vacuum time by 5 seconds, vacuum and seal again.

Seal confirmation - Inspect the pouch seal. A positive seal will appear clear upon inspection. If the seal is spotty or incomplete, increase the seal time by 0.1 second. If the seal appears white or milky, decrease the seal time by 0.1 second. Once the settings are determined for your application, vacuum and seal again. If the product is vacuumed and sealed tightly, then the process is complete.

The VP95 has several unique features that allow you to get the most out of vacuum packaging. One of these features as mentioned on page 6 is the marinate function. Now you can marinate your meat, chicken, fish or any other food product in minutes. This is achieved by running a series of vacuum cycles where air is removed then released back into the chamber, which allows the marinade or sauce to absorb quicker into the food product.

1. **Fill the pouch and place inside the chamber**

Fill the pouch with the product and marinade then place the pouch inside the chamber. Be sure to follow procedures in step 1 on How to Use page.

2. **Start the marinate process**

Close the lid then press and hold the Marinate button for 3 seconds. When the F3 code appears on the display panel, release the button.

3. **Change the amount of marinate cycles** - Use the Increase and Decrease buttons to select number of seal cycles, up to 40.

4. **Select seal time** - Press the Marinate button again. The Seal Time will show on the display panel. Push Marinate button again to set the seal time. (Unless you change bag thickness, leave seal time to last used setting.)

5. **Begin marinating** - Be sure the lid is fully closed and press the start button.

6. **End of Cycle** - The display will count down from the number of marinate cycles you set. After the last cycle, the machine will begin the final vacuum cycle to remove all air from chamber, then seal the bag. Once complete, you may lift the lid and remove pouch for inspection.

7. **Inspect the pouch**

See instructions on the How to Use page.

Vacuum Pump Maintenance

This machine requires periodic oil changes. Required oil change schedule:

- First Change: **one week** after use.
- Future Change: every 3 months or 250 cycles, whichever comes first.

Check the oil level and color frequently using the **OIL SITE GLASS**. Oil must remain between 1/2 and 3/4 in the **OIL SITE GLASS**.

- With use, the pump oil will become cloudy or dark. Once oil becomes discolored, replace with new VacMaster® vacuum oil.

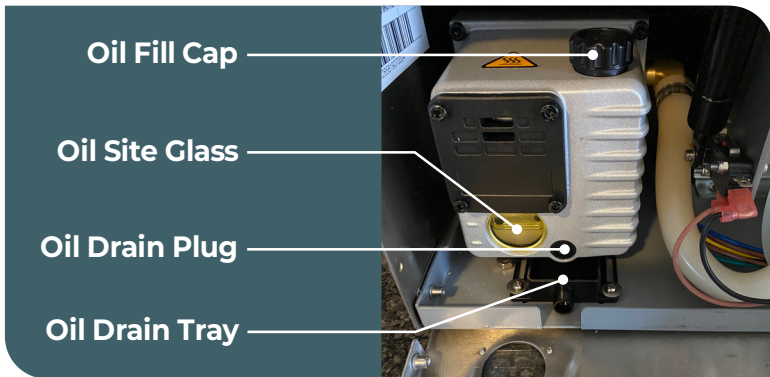

To Change the Vacuum Pump Oil:

1. Run vacuum process a couple of times to "warm up" the oil.
2. Turn off machine and unplug to prevent electrocution.
3. Locate the **OIL DRAIN PLUG & FILL CAP** on the unit.
4. Locate **OIL DRAIN PLUG** on front of vacuum pump.
5. Pull the **OIL DRAIN TRAY** forward.
6. For access and ease of draining the oil, position machine so the drain bolt is "clear" and the dirty oil can be captured.
7. Oil will flow immediately when bolt is removed. Place catch cup underneath before removing drain bolt.
8. Capture oil from pump. When oil is completely drained, replace and tighten **OIL DRAIN PLUG**. (Dispose of used oil properly)
9. Follow the "**Adding Oil to Vacuum Pump**" instructions on Page 3 of manual. **DO NOT USE MACHINE UNTIL OIL HAS BEEN ADDED.**

Recommended settings:

- Seal Time = 2 seconds
- Cool Down Time = 3 seconds
- For optimal performance use VacMaster® Vacuum Chamber Pouches and Accessories.
- Delicate foods can be frozen prior to packaging to protect them from being crushed by the vacuum process.
- Use VacMaster® Bone Guards to cover sharp edges to prevent pouch punctures.
- Allow foods and liquids to cool to room temperature before vacuum packaging.
- Max pouch size is 9"x 12"
- Avoid overfilling the pouch. Leave a minimum of 3" of space between the contents and the open end of the pouch. This is called "head space". It will help prevent spills during the vacuum sealing process. Different products require different head space - adjust accordingly.
- VacMaster® pouches can be boiled, frozen, microwaved, and are suitable for sous vide cooking. When microwaving, it is important to pierce or make a small cut in the pouch.

VacMaster Bags & Rolls



ITEM #	DESCRIPTION	#	ITEM#	DESCRIPTION	#
30765	2.5" X 10" Vacuum Chamber Pouches 3-Mil 2000/Box	3x	30788	7 X 9 Vacuum Chamber Pouches 3-Mil 1000/Box	1x
30766	6" X 7" Vacuum Chamber Pouches 3-Mil - 1000/Box	1x	30789	7 X 11 Vacuum Chamber Pouches 3-Mil 1000/Box	1x
30742	6" X 8" Vacuum Chamber Pouches 3-Mil - 1000/Box	1x	30791	7 X 12 Vacuum Chamber Pouches 3-Mil 1000/Box	1x
30608	6" X 8" Vacuum Chamber Pouches 4-Mil - 1000/Box	1x	40722	8" X 10" Pouches 3-Mil Flat Vacuum Chamber Pouches 500/Box	1x
30720	6" X 8.5" Vacuum Chamber Pouches 3-Mil - 1000 /Box	1x	30722	8" X 10" Vacuum Chamber Pouches 3-Mil - 1000/Box	1x
30750	6" X 8.5" Re-Therm Vacuum Chamber Pouches 3-Mil 1- 000/Box	1x	30614	8 X 10 Vacuum Chamber Pouches 4-Mil 1000/Box	1x
30721	6" X 10" Vacuum Chamber Pouches 3-Mil - 1000/Box	1x	50719	8 X 10 Zipper Vacuum Chamber Pouches 3-Mil 1000/Box	1x
30610	6" X 10" Vacuum Chamber Pouches 4-Mil - 1000/Box	1x	30723	8" X 12" Vacuum Chamber Pouches 3-Mil 1 000/Box	1x
50717	6" X 10" Zipper Vacuum Chamber Pouches 3-Mil - 1000/Box	1x	40751	8 X 12 Re-Therm Vacuum Chamber Pouches 3-Mil 1000/Box	1x
40721	6" X 12" Pouches 3-Mil Flat Vacuum Chamber Pouches - 500/Box	1x	30754	8 X 12 Vacuum Chamber Pouches 4-Mil 1000/Box	1x
30743	6" X 12" Vacuum Chamber Pouches 3-Mil - 1000/Box	1x	50720	8 X 12 Zipper Vacuum Chamber Pouches 3-Mil 1000/Box	1x
30612	6" X 12" Vacuum Chamber Pouches 4-Mil - 1000/Box	1x	30777	9 X 12 Vacuum Chamber Pouches 3-Mil 1000/Box	1x
50718	6" X 12" Zipper Vacuum Chamber Pouches 3-Mil - 1000/Box	1x			

Oil Cleaning Button function

The oil cleaning program runs the vacuum pump for 30 cycles. During this program, pump and oil reach operating temperature. Moisture in the pump is absorbed by the oil. The high temperature causes any moisture in the pump to evaporate, and minimizes the risk of corrosion.

It is advisable to run the program after the machine has been stationary for a lengthy period of time.

To Activate Oil Cleaning:

- Press the Oil Cleaning button.
- Close the lid to start the oil cleaning program.
- The oil cleaning program will run for 30 cycles.

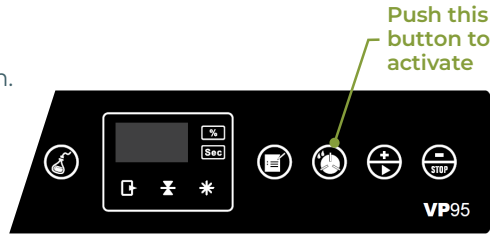

Always Remember to:

- Disconnect the power cord from the electrical outlet by unplugging it. **DO NOT** disconnect by pulling on the cord.
- **DO NOT** immerse in water or spray directly with liquid.
- Check the Vacuum Chamber and Gasket, making sure they are clean and free of debris. If needed, use a clean, damp cloth with mild soap.
 - a. Wipe the vacuum chamber clean.
 - b. Wipe the gasket and seal pad clean.
 - c. Wipe the seal area clean.
- **DO NOT** store the VP95 outside.
- Designed to operate w/in 65° to 75° range. Operating outside this temperature range may cause adverse effects on overall operation.
- **DO NOT** use any acetone-based or abrasive cleaners on plastic parts. Only clean with a damp cloth and mild soap.

VP95 will not turn on -

- Make sure the machine is properly plugged into a grounded outlet.
- Check the power cord for tears and frays. Do not use this machine if the power cord is damaged.
- Make sure the power switch is turned on. The LED screen will be illuminated when on.
- If you see 'ERR' displayed on the LED screen and the machine will not function, make sure the lid is open and turn the power off. Turn the machine back on and it should return to working order.

VP95 does not pull a complete vacuum with pouch -

- The vacuum time may not be set high enough. Set the vacuum time higher and vacuum again.
- The seal bar, seal pad, lid gasket and vacuum pouch need to be clean, dry and free of debris for the vacuum process to be successful. Wipe surface of the seal bar, seal pad, lid gasket and the inside of the pouch and try again.

Vacuum pouch loses vacuum after being sealed -

- Sharp items can poke small holes in pouches. To prevent this, cover sharp edges with VacMaster® Bone Guard and vacuum in a new pouch.
- Some fruits and vegetables can release gases (out gassing) if not properly blanched or frozen before packaging. Open the pouch. If you think food spoilage has begun, discard the food. If food spoilage has not yet begun, consume immediately. If in doubt, discard the food.

VP95 is not sealing pouch properly -

- The seal time may not be long enough. Increase the seal time and try again.
- Pouches will not seal if any moisture, food particles or debris are present in the seal area. Wipe the inside of the pouch clean and try again.
- Pouches must be properly placed along the seal bar. Make sure the entire pouch is over the seal bar and there are no wrinkles in the pouch material.
- Higher elevation may cause the vacuum degree readout to not register at 100%. However, the machine will still be getting a good vacuum.

ED = End, ready for new cycle.

**If problems persist, contact Customer Service at
(800) 821-7849 or TechSupportARY@aryinc.com**

- Follow all food safety regulations as outlined at www.FDA.gov
- Vacuum packaging is NOT a substitute for canning.
- Vacuum packaging is NOT a substitute for refrigeration or freezing.
- Vacuum packaging cannot reverse the deterioration of foods.
- All perishable foods must be refrigerated or frozen.
- Some fruits and vegetables may release gases, known as outgassing. When packaging these fruits and vegetables, outgassing can cause the vacuum to be gradually lost over time. Blanching or freezing before vacuum packaging helps prevent this from occurring.
NOTE: Due to the risk of anaerobic bacteria, soft cheeses, fresh mushrooms, garlic and onions should never be vacuum packaged.
- It is critical that food handling and storage are maintained at low temperatures. You can reduce the growth of microorganisms at temperatures of 34°F or less. Freezing at 0°F will not kill microorganisms, but reduces the chances of them growing. For long-term food storage, always freeze foods that have been vacuum packaged.
NOTE: Beef and other proteins may look darker after being vacuum packaged. This is due to the removal of oxygen and is not an indication of spoilage.

For your safety, always follow these basic precautions:

- Read this users guide carefully for operating instructions.
- Do not use in a dusty or corrosive environment.
- To protect against electrical shock, do not immerse any part of the vacuum sealer, power cord, or plug in water or any other liquid.
- Unplug the machine before cleaning or when not in use.
- To disconnect, unplug the power cord from the electrical outlet. Do not disconnect by pulling on the cord.
- Do not operate the VP95 if it has a damaged cord or plug.
- Do not operate the VP95 if it malfunctions or is damaged. **Contact Customer Service at 800-821-7849.**
- Use the VP95 only for its intended use.
- The VP95 has a grounded plug. Use only a grounded electrical outlet. To reduce risk of electrical shock, do not modify the plug in any way.
- Do not use an extension cord.
- The power cord should not drape over a counter or tabletop, as the cord could be tripped over or pulled on unintentionally.
- Do not place or operate near an electric or gas burner, or a heated oven.
- Do not use outdoors.

COVER PARTS

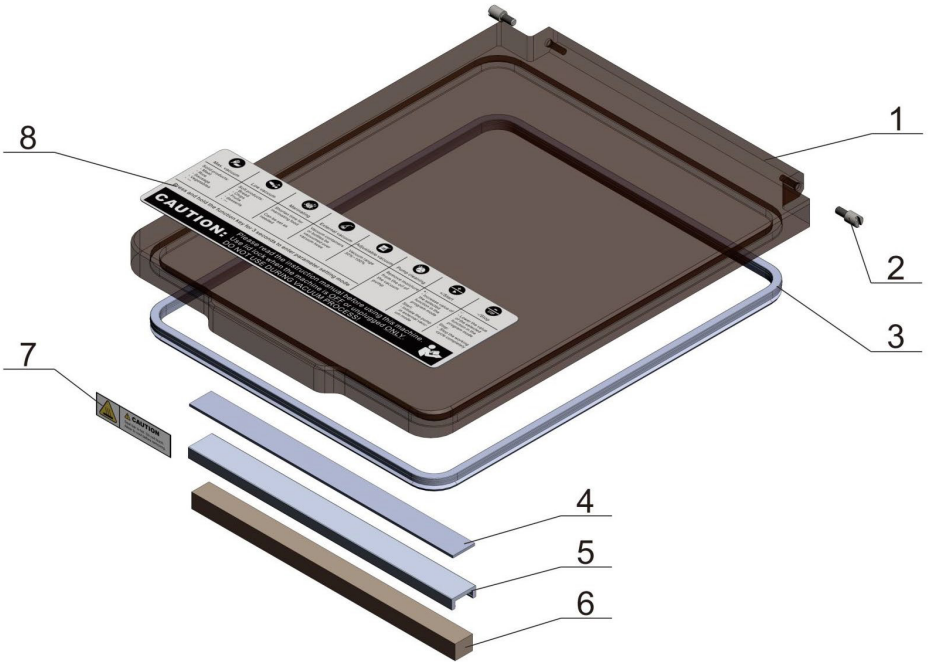

	Part #	Part Name	Qty
1	959021	Organic Cover	1
2	959022	Connecting Screw	2
3	959003	Lid Gasket	1
4	979825	Top Bar Double Sided Tape	1
5	959023	Seal Pad, Top Bar Holder	1
6	959024	Seal Pad	1
7		Warning Label	1
8	959025	Lid Decal for Setting Options	1

VACUUM CHAMBER PARTS

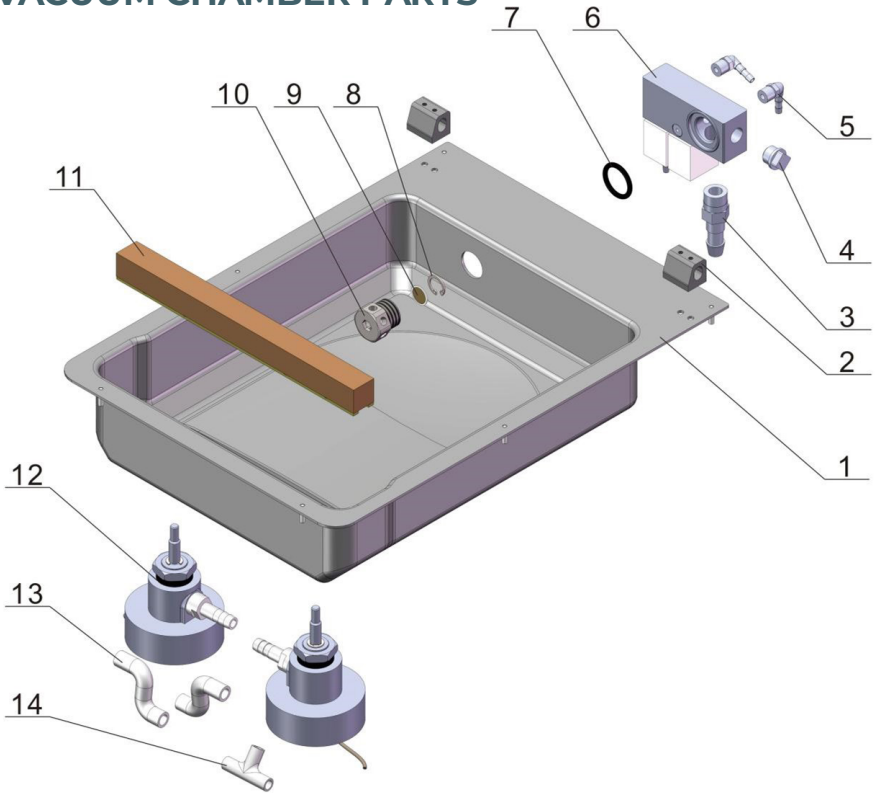

Part #	Part Name	Qty
1	Vacuum Chamber Components	1
2	Organic Cover Seat	2
3	Pagoda Joint	1
4	Plug	1
5	Pagoda Elbow	2
6 959009	Transmitter	1
7	O-ring	1
8	Retaining Ring	1
9	Edge Filter	1
10	Extraction Joint	1
11 959008	Seal Bar Assembly	1
12 959007	Piston Assembly	2
13	Silicone Rubber Vacuum Tube	1
14 959006	Tee, Piston Hose	1

CASE PARTS

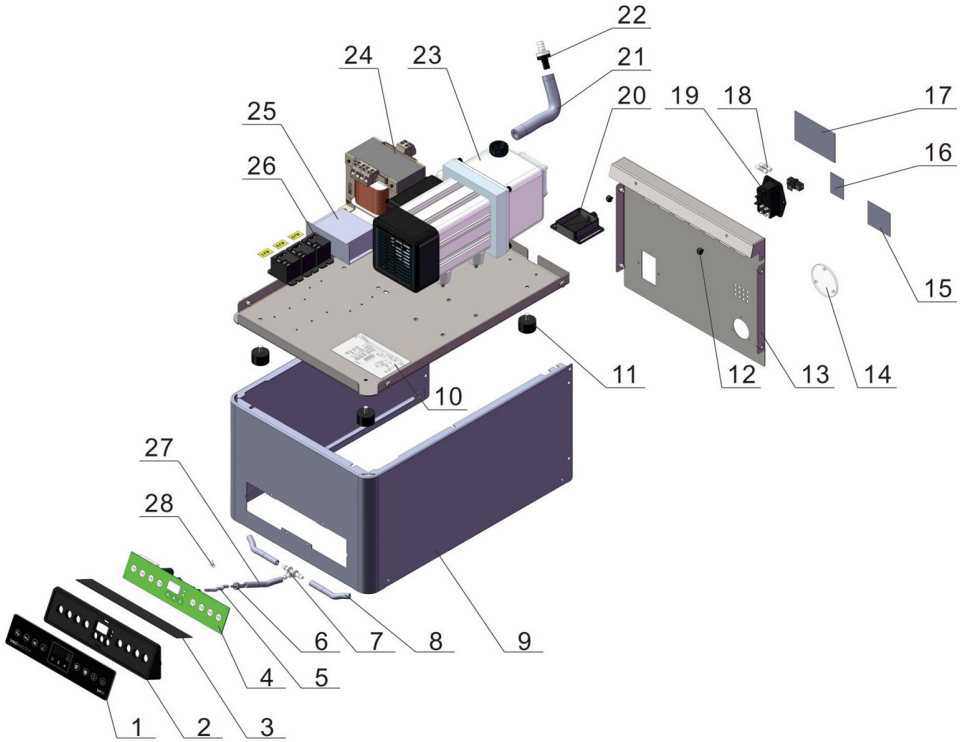

Part #	Part Name	Qty	
1	959026	Faceplate, Glass	1
2	959019	Faceplate, Panel	1
3		Water Flap	1
4	959036	Circuit / Main Board	1
	959018	Circuit / Main Board (Prior 2023)	1
5	959027	Imported Silicone Tube	1
6	959028	Reducer Straight Fitting	1
7	959029	Tee Plastic Joint	1
8	959030	Imported Silicone Tube	1
9		Chassis	1
10		Stickers	1
11	959031	VE Shockproof Feet	4
12		Cushion	2
13		Back Cover	1
14	959016	Oil Sight Glass	1

Part #	Part Name	Qty	
15		Self-adhesive Label	1
16		Self-adhesive Label	1
17		Stainless Steel Nameplate	1
18	959037	Fuse Tube (5A)	2
19	959032	3 in 1 Socket	1
20	959014	Oil Pan	1
21	959033	Silicone Rubber Vacuum Tube	1
22	959034	Diaphragm check valve	1
23	959013	Vacuum Pump	1
24	959015	Sealing Transformer	1
25	959038	Switching Power Supply	1
26	979466	Power Relay	3
27		Bottom Plate	1
28	959035	Quick Clamp	1

SKU:	Machine Type:	Chamber Size:
VP95	Countertop Chamber	9.5" X 10.5" X 3.25"
Seal Bar Length:	Distance Between Bars:	Vacuum Pump:
9.25"	N/A	Single Piston Oil Pump
Cycle Time:	Electrical Specs:	Machine Dimensions:
20-60 Seconds	110V, 60Hz, 4.2 Amps	11" X 16" X 9"
Weight:	Maximum Bag/ Pouch Size:	Compatible Bags/ Pouches:
42.5 lbs	9" X 12"	Chamber Vacuum Sealer Pouches

Includes:

Accessory Hose
User's Guide

Want Recipes, Tips and Videos?

Check out our Blog or find us on Online!



Check out our Blog:

vacmasterfresh.com/fresh-bites-blog/

Check out our  YouTube Channel:

youtube.com/@VacMasterFresh

Or Find Us On Social:



<https://www.facebook.com/vacmasterfresh>



<https://twitter.com/VacMasterFresh>



<https://www.instagram.com/vacmasterfresh>

ARY, Inc., a distributor and manufacturer of vacuum packaging and other machines (collectively, the "Goods"), extends to the purchaser of the Goods a Limited One Year Warranty, from the receipt of the Goods, under terms and conditions set out herein.

All Goods sold by ARY, Inc. are warranted to be free from defects in material and workmanship at the time of delivery to purchaser. Defective material may be returned to ARY, Inc. after inspection by an agent of ARY, Inc. and upon receipt from ARY, Inc. of shipping instructions specific to the defective Goods authorized by ARY, Inc. to be returned. ARY, Inc. at its sole option, may either (i) replace or repair any defective materials and workmanship (and return the Goods to purchaser without charge), (ii) refund the purchase price, or (iii) grant a reasonable allowance with the foregoing procedure.

This warranty is subject to the following limitations:

- i. ARY, Inc.'s responsibility and the purchaser's exclusive remedy under this warranty is limited to the repair or replacement of defects in material and workmanship, refund of the purchase price, or grant of a reasonable allowance on account of such defects, all as set forth above. ARY, Inc. is not responsible for any consequential damages resulting from the breach of this or any other express or implied warranty with respect to the Goods.
- ii. This express warranty is the only warranty applicable. It excludes all other express oral or written warranties and all warranties implied by law with respect to the Goods, including any warranties or merchantability or fitness for a particular purpose.
- iii. Every claim under this warranty shall be deemed waived by purchaser unless made in writing within one (1) year of the receipt of the Goods to which such claim relates.
- iv. This warranty, as to the Goods, is void (a) to repairs made by anyone other than ARY, Inc. without prior authorization from ARY, Inc., (b) to performance of any system of which ARY, Inc.'s Goods are a component part, (c) to deterioration by corrosion or any cause of failure other than defect of material or workmanship, (d) to any components of the Goods, including, without limitation, Teflon tape, lid gaskets and seal wire, or (e) if any of the Good or parts thereof have been tampered with or altered by someone other than ARY, Inc., or subjected to misuse, neglect, abuse, or misuse in application.

ARY, Inc.'s maximum liability hereunder, arising from any cause whatsoever, whether based in contract, tort (including negligence), strict liability, or any other theory of law, shall not exceed the purchase price. A suit based on any aforementioned cause of action must be commenced within one year from the date said action accrues.

Register your product and get technical support at:

www.vacmasterfresh.com/product-registration/
vacmasterfresh.com/contact-us/

A Product of

VACMASTER

P.O. Box 412888
Kansas City, MO 64141

VacMasterFresh.com

800.821.7849

All Rights Reserved. VacMaster® is a trademark or registered trademark of ARY, Inc.
in the United States and other countries.