

USER GUIDE

VACMASTER[®]

VP800

DOUBLE CHAMBER VACUUM SEALER



Welcome

The **VacMaster® VP800 Double Chamber Vacuum Sealer** was designed to boost packaging operations and maximize efficiency. Two 32.25-inch seal bars located in the vacuum chamber provides plenty of options for sealing a variety of chamber pouches to maximize your vacuum packaging operations. The optional gas flush feature allows for the addition of anaerobic gas mixture, which gives you the ability for packaging delicate items such as pasta or chips. The commercial-grade, 3.25 hp oil pump delivers a quick and quality vacuum in 20-30 seconds. A table height, flat deck design reduces the time loading and offloading of products. 4-inch smooth-rolling casters allow the VacMaster VP800 to be moved easily. The base is constructed of stainless steel with fully skirted access panels to promote easy sanitation. The easy to use control panel lets you set the vacuum, seal and cool time. Bag locks on the seal bar gasket reduce bag movement during busy production cycles. The VP800 is ideal for hotels, commissaries and larger catering providers that need to package large quantities of food for events.

For your safety and protection, carefully read and follow this guide. For more information, to Register your product or get support please visit us at VacMasterFresh.com

Contents

Safeguards.....	4
Tips.....	5
Features.....	6
Control Panel	7
How To.....	8
Troubleshooting	13
Cleaning and Storage	14
Vacuum Packaging Guidelines	15
Parts.....	16
Packaging Info.....	19
Specs.....	20
More Resources	21
Warranty and Registration.....	22
Notes.....	23



YOU MUST ADD OIL BEFORE USE!

**FAILURE TO DO SO WILL
DAMAGE THE PUMP!**

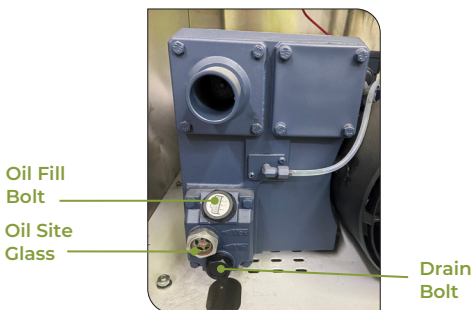

Required Supplies:

- 1/2 Quart VacMaster Machine Oil
- Phillips Head Screwdriver
- Empty Oil Bottle with Spout

Adding Oil to VP800

- 1. Prepare the Oil:** The VP800 includes a Maintenance Kit that contains a 1/2 quart of oil and an empty oil bottle with spout. Fill the empty oil bottle with oil.
- 2. Remove the Back Panel:** Using the enclosed Phillips head Screwdriver, remove the four screws from the back panel and take the panel off of the machine.
- 3. Remove the Oil Fill Cap:** Locate the oil fill cap on the vacuum pump and unscrew it.
- 4. Fill the Pump with Oil:** Insert the spout into the open hole (oil fill cap opening) and begin pouring the oil into the pump. Fill the pump until the oil level is at 1/2 to 3/4 in the site glass. This is approximately 64 ounces of oil.
- 5. Replace the Oil Fill Cap and Back Panel:** Once the pump is filled with oil, screw the oil fill cap back on and put the back panel back on the machine.

The VP800 Chamber Vacuum Sealer is now ready for use.

WARNING: When using electrical appliances, basic safety precautions should always be followed to reduce the risk of fire, electric shock, and/or injury to persons, including the following:

1. Read all instructions.

2. This appliance is not intended for use by persons with reduced physical, sensory, or mental capabilities, or lack of experience and knowledge, unless they are closely supervised and instructed concerning use of the appliance by a person responsible for their safety.

3. This appliance is not to be used by children. Close supervision is necessary when any appliance is used near children. Children should be supervised to ensure that they do not play with the appliance.

4. Never let the vacuum sealer run unattended. Disconnect the vacuum sealer from the power source before leaving the work area.

5. To protect against risk of electric shock, do not immerse cord, plug, or vacuum sealer in water or other liquid.

6. To reduce the risk of electric shock and injury to persons, disconnect from power supply when not in use, before cleaning and before servicing.

7. To provide continued protection against risk, do not operate any appliance with a damaged supply cord or plug, or after the appliance malfunctions or has been dropped or damaged in any manner. Supply cord replacement and repairs must be conducted by the manufacturer, its service agent, or similarly qualified persons in order to avoid a hazard. Call the provided customer service number for information on examination, repair, or adjustment.

8. The use of accessory attachments not recommended by the appliance manufacturer may cause injuries.

9. Do not use outdoors. Optimal operating temperature range is 65° to 75°.

10. Do not let cord hang over edge of table or counter, or touch hot surfaces, including stove.

11. Do not disassemble this appliance beyond instructions provided. Doing so may result in personal injury.

12. Do not place on or near a hot gas or electric burner, or in a heated oven.

13. Do not use for other than intended purpose.

14. This appliance is designed for a maximum vacuum ON time of 70 seconds and a minimum OFF time of 10 seconds between cycles. Stop the appliance and allow it to cool to ambient temperature if the appliance has been in use for 45 minutes.

15. This appliance is for commercial use only.

- Vacuum packaging is not a substitute for canning. All perishables still need to be refrigerated or frozen.
- Follow all food safety regulations as outlined by the FDA at www.FDA.gov.
- Use only VacMaster® Vacuum Chamber Pouches and accessories.
- Some fruits and vegetables may release gases, known as outgassing. When packaging these fruits and vegetables, outgassing can cause the vacuum to be gradually lost over time. Blanching or freezing before vacuum packaging helps prevent this from occurring.
- Delicate foods can be frozen prior to packaging to protect them from getting crushed by the vacuum.
- Use VacMaster® Bone Guards to cover an item's sharp edges to prevent pouch punctures.
- Allow foods and liquids to cool to room temperature before vacuum packaging.
- Avoid overfilling the pouch. Leave a minimum of 3" of space between the contents and the open end of the pouch. This is called head space. This will prevent spills during the vacuum sealing process.
- To prevent wrinkles from forming in the seal, gently stretch the pouch flat along the seal bar before closing the lid.
- VacMaster® pouches are boilable, freezable, and microwavable. When microwaving, it is important to pierce or make a small cut in the pouch.

VP800 Features



1. Vacuum Chamber
2. Control Panel
3. Power Switch
4. Seal Pad
5. Locking Casters

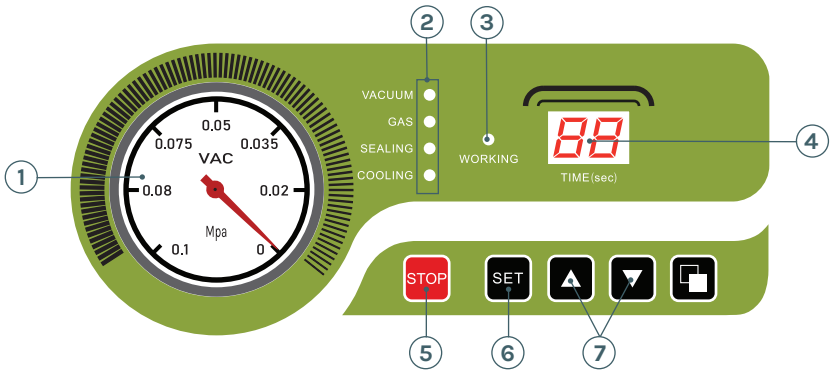

1. **Vacuum Gauge** - Indicates the vacuum level inside the chamber.
2. **Function Lights:**
 - Vacuum** - Illuminates to adjust vacuum time as well as during the vacuum process. During set up, adjust the vacuum time using the UP/DOWN Buttons.
 - Gas** - This model offers the gas flush option. See page 8 for details.
 - Sealing** - Illuminates to adjust vacuum time as well as during the sealing process. During set up, adjust the sealing time using the UP/DOWN Buttons.
 - Cooling** - Illuminates to adjust vacuum time as well as during the cooling process. During set up, adjust the cooling using the UP/DOWN buttons.
3. **Working Indicator Light** - Illuminates to indicate the machine is in use.
4. **LED Screen (Time)** - Displays current function or cycle time, measured in seconds.
5. **STOP Button** - Press to stop the cycle and immediately seal the pouch. This button will only work when the machine is in the vacuum process.
6. **SET Button** - Press to select the vacuum time, sealing time, or cooling time. Use with the UP/DOWN buttons.
7. **UP/DOWN Buttons** - Press to increase or decrease vacuum time, sealing time, or cooling time.

Adding Oil to the VP800

Required Supplies:

- 1/2 quart VacMaster machine oil
- Empty oil bottle with spout
- Phillips head screwdriver
- Adjustable wrench (not included)

- 1. Run vacuum process a couple of times to "warm up" the oil.**
- 2. Prepare the Oil:** The VP800 includes a maintenance kit that contains a 1/2 quart of oil and an empty oil bottle with spout. Fill the empty oil bottle with oil.
- 3. Remove the Back Panel:** Using the enclosed Phillips head screwdriver, remove the four screws from the back panel and take the panel off the machine.
- 4. Remove the Oil Fill Bolt:** Locate the oil fill bolt on the vacuum pump and remove it using an adjustable wrench or similar tool.
- 5. Fill the Pump with Oil:** Insert the spout into the open hole (oil fill bolt opening) and begin pouring the oil into the pump. Fill the pump until the oil level is at 1/2 to 3/4 in the site glass. This is approximately 10 to 12 ounces of oil.
- 6. Replace the Oil Fill Bolt and Back Panel:** Once the pump is filled with oil, screw the oil fill bolt back in place and put the back panel on the machine. The VP800 Chamber Vacuum Sealer is now ready for use.

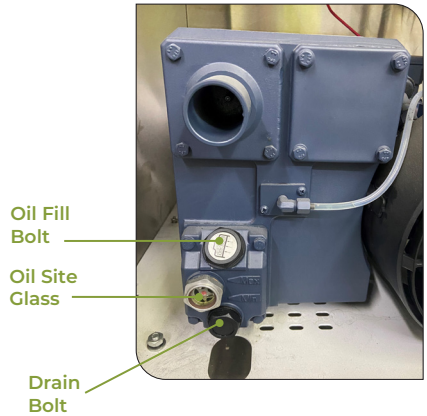

Required oil change schedule:

First Change: one week after use.

Future Change: every 3 months or 250 cycles, which ever comes first.

Set Up - Powering up the VP800

Please read all instructions before operating the VP800

1. Attach the power cord and plug the machine into a grounded electrical outlet - Properly insert the electrical cord into the power outlet on the back of the machine and then plug the cord into the wall outlet.
2. Open the machine lid - Release the lid lock, located on the right side of the machine, and allow the lid to lift and remain open.

IMPORTANT: DO NOT turn the machine on until the lid lock has been released, The lid lock feature is used **ONLY** to keep the lid closed while the machine is in storage.

3. Turn the power switch on - Turn the red switch on the left side of the machine toward the front, switching from the “0” to the “1” position. The LED Screen on the control panel will illuminate showing a  symbol.



Set Up - Adjusting the VP800 Timing Controls

NOTE: All timing adjustments must be made with the lid lock off and the lid open.

To adjust/set the timing controls, press the SET button on the control panel until the required label (Vacuum, Sealing or Cooling) is illuminated. For each selection, the current time setting will show on the LED Screen. All time settings are displayed in seconds.

For initial testing, the time settings should be:

Vacuum Time - 40 seconds

Sealing Time - 2 seconds

Cooling Time - 3 seconds

To change the settings, please read **“Adjusting the VP800 Timing Controls”** on Page 10.

Adjusting the VP800 Timing Controls (Cont'd)

Vacuum Time: To increase or decrease the vacuum time, press the SET button until VACUUM is illuminated and then use the UP/DOWN buttons to adjust the vacuum time accordingly. The time setting will display on the LED Screen on the control panel.

NOTE: Filler plates can be used to reduce the vacuum time required. Place the filler plates inside the chamber as desired. Filler plates occupy space, leaving less air to be removed from the chamber. If you require more space inside the chamber, remove the filler plates to accommodate your product.

Sealing Time: To increase or decrease the sealing time, press the SET button until SEALING is illuminated and then use the UP/DOWN buttons to adjust the sealing time to accommodate your application. It is recommended that you make adjustments in 0.1 second increments to avoid melting the pouch.

NOTE: For thicker pouches, increase the seal time in 0.2 second increments until the pouch seals completely. In addition, for thinner pouches, decrease the seal time in 0.1 second increments to avoid over-sealing the pouch.

Cooling Time: To increase or decrease the cooling time, press the SET button until COOLING is illuminated and then use the UP/DOWN buttons to adjust the cooling time accordingly.

NOTE: The VP800 settings will always default to the most recently used settings on the machine.

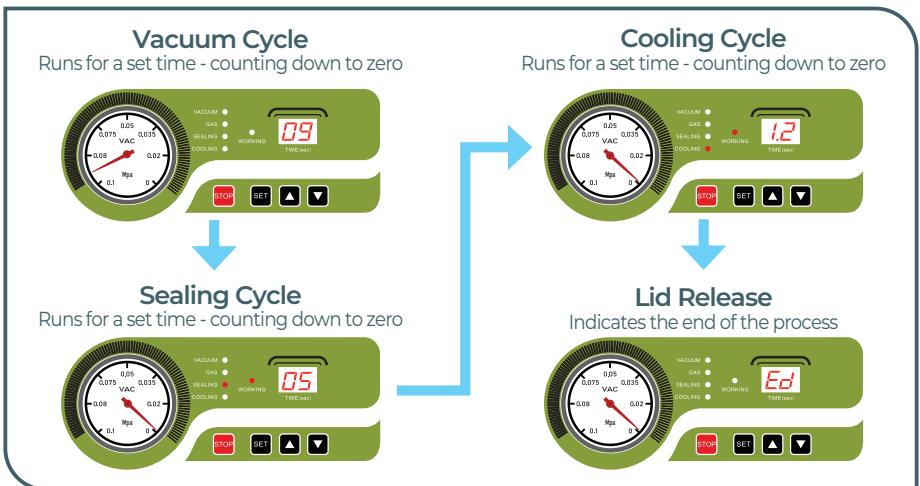

Sealing with a Chamber Pouch

NOTE: After setting the timing controls, press the SET button until the function lights on the Control Panel are no longer illuminated. The machine will not start until all function lights are off.

1. Select a vacuum chamber pouch

Select the proper size of vacuum chamber pouch for the product that you are packaging. Make sure that the mouth of the pouch does not exceed the length of the seal bar and make sure the entire pouch fits inside the chamber. Allow 3" of extra headspace at the top of the pouch to ensure a quality, air-tight seal. The VP800 accepts vacuum chamber pouches up to 28" x 28" in size.

2. Fill the pouch and place inside the chamber

Fill the pouch with the product to be vacuum packaged and place the pouch inside the chamber. Keep pouches that contain liquids or wet product below the height of the seal bar. Lay the pouch flat inside the chamber, with the opening of the pouch across the seal bar. Make sure that the pouch lies flat across the seal bar and is free of wrinkles.

NOTE: The entire pouch, including the opening, must remain inside the chamber.

3. Close the machine lid to vacuum and seal

Close the lid and press down firmly for 2-3 seconds or until the vacuum gauge begins to move.

4. Inspect the pouch

When the lid opens, remove and inspect the pouch.

Vacuum confirmation - Check the quality of the vacuum by looking at the tightness of the pouch and the product. Look for air pockets or air leaks. If you notice that the product is not vacuum packaged tightly, then increase the vacuum time by 5 seconds, vacuum and seal again.

Seal confirmation - Inspect the pouch seal. A positive seal will appear clear upon inspection. If the seal is spotty or incomplete, increase the seal time by 0.1 second. If the seal appears white or milky, decrease the seal time by 0.1 second. Once the settings are determined for your application, vacuum and seal again. If the product is vacuumed and sealed tightly, then the process is complete.

5. ED Code - stands for end of demonstration. You are ready for a new cycle.

TIP: To prolong the life of your seal bar, set the cooling time to twice the sealing time.

Gas Flush System

Products which would be damaged by high pressure must be subjected to a lower vacuum or the pressure must be counterbalanced by inflating the bag with inert gas.

The gas flush system is designed to remove the oxygen and replace it with a mixture of Carbon Dioxide and Nitrogen to extend shelf life and provide a higher quality product of the consumer. This is beneficial when packaging items that shouldn't be compressed. This includes but is not limited to soft fruits, dried foods, chips, pasta, and pre-cooked meals. By adding a mixture of Carbon Dioxide and Nitrogen, the food will stay fresh longer while keeping its original shape.

How to Use:

Consult your local authorized gas supplier for assistance in buying, regulating, and connecting the gas to the machine.

Gas Fill Operating Instructions:

Connect the required gas cylinder (complete with regulator), to the machine by hose. The Regulator may never be set more than atmosphere pressure, approximately 14 psi. The appropriate level should be between 5 and 12 psi.

To add gas flush to the normal operating cycle, follow the operating instructions. If there is no gas flush time set, there will be no gas flush in the process of sealing. To use the gas flush add increments of .1 seconds to the timer. It may take several adjustments to get the package to the desired fill level.

Air Filter Maintenance

This machine has an air filter that should be changed every 3-5 years. Please call our tech support for assistance.



VP800 will not turn on -

- Make sure the machine is properly plugged into a grounded outlet.
- Check the power cord for tears and frays. Do not use this machine if the power cord is damaged.
- Make sure the power switch is turned on. The LED screen will be illuminated when on.
- If you see 'F1' displayed on the LED screen and the machine will not function, make sure the lid is open and turn the power off. Turn the machine back on and it should return to working order.

VP800 does not pull a complete vacuum with pouch -

- The vacuum time may not be set high enough. Set the vacuum time higher and vacuum again.
- To vacuum and seal properly, the opening of the pouch must be within the vacuum chamber. For detailed instructions, refer to "**How To Use the VacMaster® VP800 Chamber Vacuum Sealer**".
- The seal bar, lid gasket and vacuum pouch need to be clean, dry and free of debris for the vacuum process to be successful. Wipe surface of the seal bar, lid gasket and the inside of the pouch and try again.

Vacuum pouch loses vacuum after being sealed -

- Sharp items can poke small holes in pouches. To prevent this, cover sharp edges with VacMaster® Bone Guard and vacuum in a new pouch.
- Some fruits and vegetables can release gases (out gassing) if not properly blanched or frozen before packaging. Open the pouch. If you think food spoilage has begun, discard the food. If food spoilage has not yet begun, consume immediately. If in doubt, discard the food.

VP800 is not sealing pouch properly -

- The seal time may not be long enough. Increase the seal time and try again.
- Pouches will not seal if any moisture, food particles or debris are present in the seal area. Wipe the inside of the pouch clean and try again.
- Pouches must be properly placed along the seal bar. Make sure the entire pouch is over the seal bar and there are no wrinkles in the pouch material.

NOTE: High elevation may cause the gauge to not go all the way into the green. You may have to increase the vacuum time by 5-10 seconds in higher elevation.

If problems persist, contact Customer Service at
(800) 821-7849 or TechSupportARY@aryinc.com

VP800 Cleaning & Storage

- Disconnect the power cord from the electrical outlet by unplugging it. **DO NOT** disconnect by pulling on the cord.
- **DO NOT** immerse in water or spray directly with liquid.
- Check the Vacuum Chamber and Gasket, making sure they are clean and free of debris. If needed, use a clean, damp cloth with mild soap.
 - a. Wipe the vacuum chamber clean.
 - b. Wipe the gasket clean.
 - c. Wipe the seal area clean.
- **DO NOT** store the VP800 outside. 65° to 75° recommended.
- **DO NOT** use any acetone-based or abrasive cleaners on the lid or other plastic parts. Only clean lid with a damp cloth and mild soap.

Maintenance Kit

1. **Exhaust Filter:** Spare filter; should be checked every 6-12 months. If the filter looks dirty or saturated in oil; it will need to be changed. If the filter looks clean; it is ok to put back into the pump & motor assembly.
2. **5-AMP Fuses (2x):** Used for replacing fuses located on the control transformer.
3. **Seal Wire:** Used to replace seal wire that spans the length of the seal bar; should be replaced if the wire shows heavy discoloration.
4. **Seal Tape:** Used to replace seal tape the covers the seal wires; should be replaced if the tape shows heavy discoloration, is torn, or is starting to lose the adhesive.
5. **Hex/Allen Wrench:** Used to remove tension blocks that hold the seal wire to the base of the seal bar.
6. **Reversible Screwdriver** Used to un-thread screws on the cabinet of the machine and the screws to move the chamber.
7. **Wire Tightening Tool:** Used to tighten seal wire that spans the length of the seal bar.
8. **Oil Fill Bottle/Oil:** Used to fill pump with oil.



VP800 Vacuum Packaging Guidelines

- Follow all food safety regulations as outlined by the FDA at www.FDA.gov.
- Vacuum packaging is **NOT** a substitute for canning. All perishables still need to be refrigerated or frozen.
- Vacuum packaging cannot reverse the deterioration of foods.
- Vacuum packaging is **NOT** a substitute for refrigeration or freezing.
- Some fruits and vegetables may release gases, known as outgassing. When packaging these fruits and vegetables, outgassing can cause the vacuum to be gradually lost over time. Blanching or freezing before vacuum packaging helps prevent this from occurring.

NOTE: Due to the risk of anaerobic bacteria, soft cheeses, fresh mushrooms, garlic and onions should never be vacuum packaged.

NOTE: Beef and other proteins may look darker after being vacuum packaged. This is due to the removal of oxygen and is not an indication of spoilage.

- It is critical that food handling and storage are maintained at low temperatures. You can reduce the growth of microorganisms at temperatures of 34°F or less. Freezing at 0°F will not kill microorganisms, but reduces the chances of them growing. For long-term food storage, always freeze foods that have been vacuumed packaged.
- Delicate foods can be frozen prior to packaging to protect them from getting crushed by the vacuum.
- Use VacMaster® Bone Guards to cover an item's sharp edges to prevent pouch punctures.
- Allow foods and liquids to cool to room temperature before vacuum packaging.
- Avoid overfilling the pouch. Leave 3" minimum of space between the contents and the open end of the pouch. This is called head space. This prevents spills during the vacuum sealing process.
- To prevent wrinkles from forming in the seal, gently stretch the pouch flat along the seal bar before closing the lid.
- VacMaster® pouches are boilable, freezable, and microwavable. When microwaving, it is important to pierce the pouch.

LID ASSEMBLY

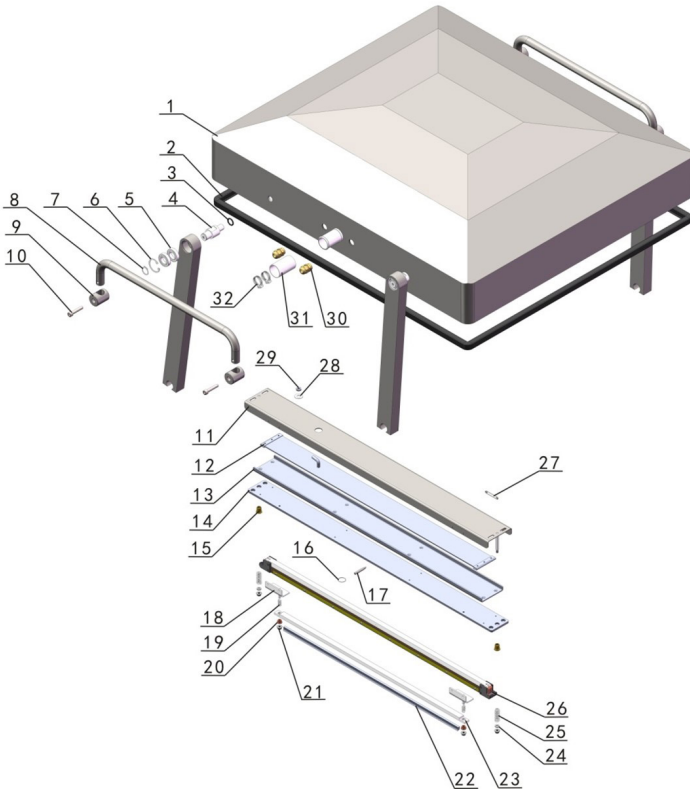

Part #	Part Name	Qty	Part #	Part Name	Qty
1	Dome	1	17	Pin	4
2	979742 Sealing strip	3.5m	18	Base strip	2
3	O ring	4	19	Spring	2
4	Short shaft	4	20	Guide sleeve	4
5	Bearing	8	21	Screw	4
6	Circle clip for hole	4	22	Sealing rubber	4
7	Circle clip for shaft	4	23	Base	4
8	Handle	2	24	Washer	1.32m
9	Handle seat	4	25	Spring	2
10	Screw	4	26	979803 Seal bar assembly	4
11	979901 Airbag assembly	2	27	Pin	4
12	Airbag seat	2sets	28	Limit plate	2sets
13	Plate	2	29	Screw	2
14	Base	2	30	Wire joint	2
15	Guide sleeve	4	31	Rubber tube	2
16	Clip	2	32	Clip	2

CHAMBER ASSEMBLY

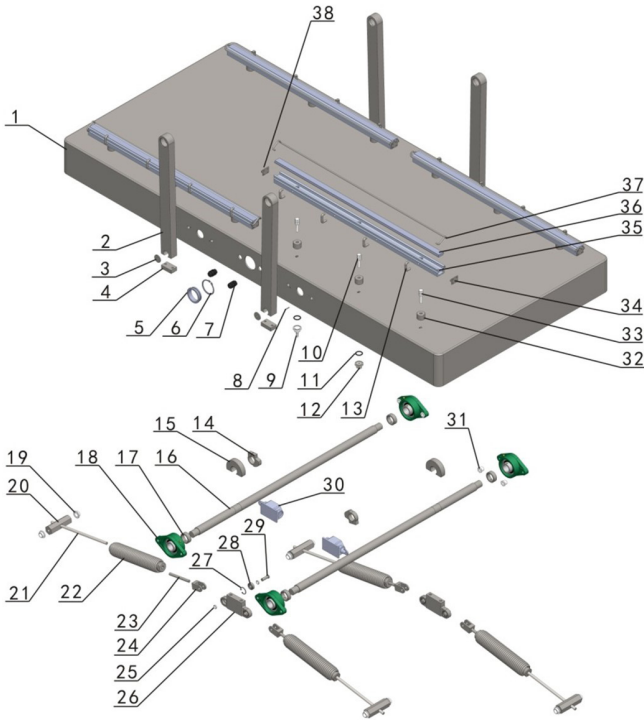

Part #	Part Name	Qty	Part #	Part Name	Qty
1	Chamber assembly	1	20	Base	4
2	Connection rod	4	21	Screw	4
3	Cover	4	22	978700 Spring	4
4	Plate	4	23	Screw	4
5	Clip	1	24	Joint	4
6	Clip	1	25	Washer	8
7	Wire joint	2	26	Rod	2
8	Pin	8	27	Clip	4
9	Joint	8	28	Bearing	4
10	Pillar	4	29	Pin	4
11	O ring	12	30	921310 Limit switch	2
12	Plug	4	31	Sleeve	8
13	Nozzle	16	32	Block	12
14	Block	2	33	Pillar	8
15	Seat	2	34	Left plate	4
16	Long shaft	2	35	979903 Sealing strip seat	4
17	Clip	4	36	979904 Sealing strip	4
18	Bearing	4	37	Press strip	4
19	Sleeve	8	38	Right plate	4

HOUSING

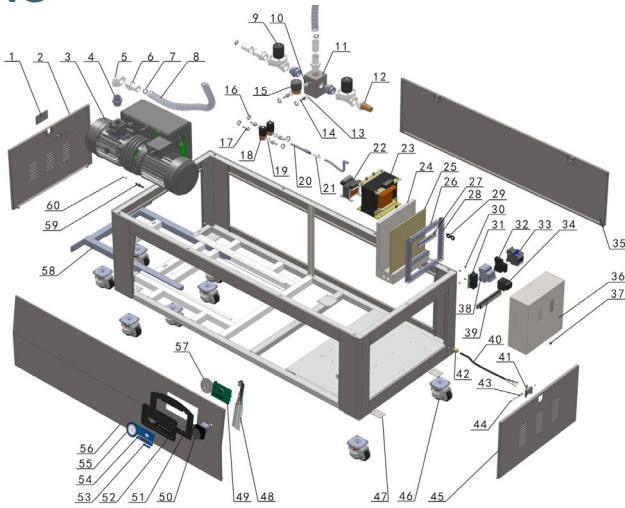

Part #	Part Name	Qty	Part #	Part Name	Qty
1	Name plate	1	32	979691 Phase protector	1
2	Side door	1	33	979690 Ac contactor	1
3	979288 Vacuum pump	1	34	Thermo relay	1
4	Joint	3	35	Back cover	1
5	Joint	1	36	Front cover for electric box	1
6	Joint	2	37	Handle	2
7	Clip	3	38	Small breaker	1
8	Steel tube	1m	39	Terminal	1
9	979707 Solenoid valve	2	40	Plastic wire	4m
10	Joint	1	41	lock	4
11	Valve seat	1	42	Wire joint	1
12	979557 Silencer	1	43	Spring	4
13	O ring	1	44	Screw	4
14	M10x1 joint	1	45	Side door	1
15	979390 Solenoid valve	1	46	Wheel	8
16	Clip	6	47	Installation board	4
17	M14x1 joint	5	48	Wires	1.2m
18	979365 Solenoid valve	2	49	977502 Board	1
19	O ring	5	50	921241 Power switch	1
20	Rubber tube	5.5m	51	sticker	1
21	T type connector	8	52	frame	1
22	989104 Heating transformer	1	53	977513 Sticker	1
23	979689 Control transformer	1	54	977504 Sticker	1
24	Electric box	1	55	977504 Sticker	1
25	Plate	1	56	Front cover	1
26	Wire slot	3	57	979126 Gauge	1
27	Guide rail	1	58	Bracket	1
28	Wire slot	2	59	Joint	1
29	Clip	2	60	Plug	1
30	Block	4			
31	979135 Relay	1	979803	SEAL BAR ASSEMBLY, FOR VP800 DOUBLE CHAMBER MACHINE	

VP800 Packaging Information

With the VP800, you can easily package a wide variety of sizes and shapes. You can also prep and store smaller individual serving portions as well as bulk items.

- Keeps food fresh 3-5 times longer than conventional storage bags.
- Several sizes available to meet your packaging needs.
- Terrific for hundreds of applications in and out of the kitchen
- Safe for freezer, refrigeration, and microwave use.
- Re-Therm pouches are reinforced to be able to handle being boiled for up to 30 minutes. The other bags can be boiled, but not for that long without being compromised. When a normal bag becomes compromised, the pouch will begin to delaminate.
- Bag thickness available in standard 3mil or heavy duty 4mil.
- Bags are economically priced, giving you a better value.

The chamber of the VP800 can easily vacuum package the following sizes of vacuum pouches:

ITEM #	DESCRIPTION	#	ITEM #	DESCRIPTION	#
30765	2.5" X 10" Vacuum Chamber Pouches 3-Mil 2000/Box	24x	30777	9 X 12 Vacuum Chamber Pouches 3-Mil 1000/Box	6x
30766	6" X 7" Vacuum Chamber Pouches 3-Mil - 1000/Box	10x	40731	10 X 8 Horizontal Vacuum Chamber Pouches 3-Mil 250/Box	6x
30742	6" X 8" Vacuum Chamber Pouches 3-Mil - 1000/Box	10x	30724	10" X 10" Vacuum Chamber Pouches 3-Mil 1000/Box	6x
30608	6" X 8" Vacuum Chamber Pouches 4-Mil - 1000/Box	10x	50724	10 X 12 Zipper Vacuum Chamber Pouches 3-Mil 1000/Box	6x
30720	6" X 8.5" Vacuum Chamber Pouches 3-Mil - 1000 /Box	10x	30620	10 X 12 Vacuum Chamber Pouches 4-Mil 1000/Box	6x
30750	6" X 8.5" Re-Therm Vacuum Chamber Pouches 3-Mil 1- 000/Box	10x	40725	10" X 13" Pouches 3-Mil Vacuum Chamber Pouches 250/Box	6x
30721	6" X 10" Vacuum Chamber Pouches 3-Mil - 1000/Box	10x	30725	10" X 13" Vacuum Chamber Pouches 3-Mil 1000/Box	6x
30610	6" X 10" Vacuum Chamber Pouches 4-Mil - 1000/Box	10x	30778	10" X 13" Vacuum Chamber Pouches 4-Mil 1000/Box	6x
50717	6" X 10" Zipper Vacuum Chamber Pouches 3-Mil - 1000/Box	10x	30776	10 X 13 Vacuum Chamber Pouches 5-Mil 1000/Box	6x
40721	6" X 12" Pouches 3-Mil Flat Vacuum Chamber Pouches - 500/Box	10x	30726	10" X 15" Vacuum Chamber Pouches 3-Mil 1000/Box	6x
30743	6" X 12" Vacuum Chamber Pouches 3-Mil - 1000/Box	10x	30749	10 X 15 Re-Therm Vacuum Chamber Pouches 3-Mil 1000/Box	6x
30612	6" X 12" Vacuum Chamber Pouches 4-Mil - 1000/Box	10x	50721	10 X 15 Zipper Vacuum Chamber Pouches 3-Mil 1000/Box	6x
50718	6" X 12" Zipper Vacuum Chamber Pouches 3-Mil - 1000/Box	10x	30752	10 X 16 Re-Therm Vacuum Chamber Pouches 3-Mil 1000/Box	6x
30787	6" X 15" Vacuum Chamber Pouches 3-Mil - 1000/Box	10x	30755	10 X 16 Vacuum Chamber Pouches 4-Mil 1000/Box	6x
30788	7 X 9 Vacuum Chamber Pouches 3-Mil 1000/Box	8x	30745	10" X 18" Vacuum Chamber Pouches 3-Mil 500/Box	6x
30789	7 X 11 Vacuum Chamber Pouches 3-Mil 1000/Box	8x	30622	10 X 18 Vacuum Chamber Pouches 4-Mil 500/Box	6x
30791	7 X 12 Vacuum Chamber Pouches 3-Mil 1000/Box	8x	30756	10 X 20 Vacuum Chamber Pouches 4-Mil 500/Box	6x
40722	8" X 10" Pouches 3-Mil Flat Vacuum Chamber Pouches 500/Box	8x	30729	10" X 22" Vacuum Chamber Pouches 3-Mil 500/Box	6x
30722	8" X 10" Vacuum Chamber Pouches 3-Mil 1000/Box	8x	30730	10" X 30" Vacuum Chamber Pouches 3-Mil 500/Box	6x
30614	8 X 10 Vacuum Chamber Pouches 4-Mil 1000/Box	8x	40726	11.5 X 13 Vacuum Chamber Pouches 3-Mil 250/Box	4x

Pouch Sizes (Cont'd)

ITEM #	DESCRIPTION	#	ITEM #	DESCRIPTION	#
40722	8" X 10" Pouches 3-Mil Flat Vacuum Chamber Pouches 500/Box	8x			
30722	8" X 10" Vacuum Chamber Pouches 3-Mil 1000/Box	8x	40733	12 X 10 Horizontal Vacuum Chamber Pouches 3-Mil 250/Box	4x
30614	8 X 10 Vacuum Chamber Pouches 4-Mil 1000/Box	8x	30727	12" X 12" Vacuum Chamber Pouches 3-Mil 1000/Box	4x
50719	8 X 10 Zipper Vacuum Chamber Pouches 3-Mil 1000/Box	8x	40728	12 X 14 Vacuum Chamber Pouches 3-Mil 250/Box	4x
30723	8" X 12" Vacuum Chamber Pouches 3-Mil 1 000/Box	8x	30728	12" X 14" Vacuum Chamber Pouches 3-Mil 1000/Box	4x
40751	8 X 12 Re-Therm Vacuum Chamber Pouches 3-Mil 1000/Box	8x	30624	12 X 14 Vacuum Chamber Pouches 4-Mil 1000/Box	4x
30754	8 X 12 Vacuum Chamber Pouches 4-Mil 1000/Box	8x	50726	12 X 14 Zipper Vacuum Chamber Pouches 3-Mil 1000/Box	4x
50720	8 X 12 Zipper Vacuum Chamber Pouches 3-Mil 1000/Box	8x	30746	12" X 15" Vacuum Chamber Pouches 3-Mil 500/Box	4x
30744	8" X 15" Vacuum Chamber Pouches 3-Mil 1000/Box	8x	30731	12" X 16" Vacuum Chamber Pouches 3-Mil 500/Box	4x
30618	8 X 15 Vacuum Chamber Pouches 4-Mil 1000/Box	8x	30783	16 X 16 Vacuum Chamber Pouches 3-Mil 500/Box	4x
50722	8 X 16 Zipper Vacuum Chamber Pouches 3-Mil 1000/Box	8x	30784	16 X 18 Vacuum Chamber Pouches 3-Mil 500/Box	4x
30767	8 X 20 Vacuum Chamber Pouches 4-Mil 1000/Box	8x	30737	16" X 20" Vacuum Chamber Pouches 3-Mil 500 /Box	4x
30786	12 X 16 Vacuum Chamber Pouches 4-Mil 500/Box	4x	30738	16" X 24" Vacuum Chamber Pouches 3-Mil 500/Box	4x
40796	12" X 16" Re-Therm Vacuum Chamber Pouches 4-Mil 500/Box	4x	30739	16" X 26" Vacuum Chamber Pouches 3-Mil 250/Box	4x
30732	12" X 18" Vacuum Chamber Pouches 3-Mil 500/Box	4x	30760	16 X 30 Vacuum Chamber Pouches 4-Mil 250/Box	4x
30757	12 X 18 Vacuum Chamber Pouches 4-Mil 500/Box	4x	30792	18 X 22 Vacuum Chamber Pouches 3-Mil 500/Box	2x
30733	12" X 22" Vacuum Chamber Pouches 3-Mil 500 /Box	4x	30761	18 X 22 Vacuum Chamber Pouches 4-Mil 500/Box	2x
30758	12 X 26 Vacuum Chamber Pouches 4-Mil 500/Box	4x	30740	18" X 28" Vacuum Chamber Pouches 3-Mil 250/Box	2x
30768	12 X 28 Vacuum Chamber Pouches 3-Mil 500/Box	4x	30741	20" X 28" Vacuum Chamber Pouches 3-Mil 250 /Box	2x
30734	14" X 16" Vacuum Chamber Pouches 3-Mil 500 /Box	4x	30747	22" X 34" Vacuum Chamber Pouches 3-Mil 250/Box	2x
30753	14 X 18 Re-Therm Vacuum Chamber Pouches 3-Mil 500/Box	4x			
30735	14" X 20" Vacuum Chamber Pouches 3-Mil 500/Box	4x			
30759	14 X 20 Vacuum Chamber Pouches 4-Mil 500/Box	4x			
30736	14" X 24" Vacuum Chamber Pouches 3-Mil 500/Box	4x			

SKU:	Machine Type:	Chamber Size:	Seal Bar Length:
VP800	Double Chamber	35.8" x 31.5" x 8.85"	32.25"
Distance Between Bars:	Vacuum Pump:	Cycle Time:	Electrical Specs:
27.5"	3.25 HP Rotary Oil Pump	20-30 Seconds	3-Phase, 220V, 30A
Machine Dimensions:	Weight:	Maximum Bag/ Pouch Size:	Compatible Bags/ Pouches:
75"x 41" x 40"	1100 lbs	28" x 28"	Chamber Vacuum Sealer Pouches
Includes:			

Maintenance Kit
User's Guide

Want Recipes, Tips and Videos?

Check out our Blog or find us on Online!



Check out our Blog:

vacmasterfresh.com/fresh-bites-blog/

Check out our  YouTube Channel:

youtube.com/@VacMasterFresh

Or Find Us On Social:



<https://www.facebook.com/vacmasterfresh>



<https://twitter.com/VacMasterFresh>



<https://www.instagram.com/vacmasterfresh>

VP800 Limited Warranty

ARY, Inc., a distributor and manufacturer of vacuum packaging and other machines (collectively, the "Goods"), extends to the purchaser of the Goods a Limited One Year Warranty, from the receipt of the Goods, under terms and conditions set out herein.

All Goods sold by ARY, Inc. are warranted to be free from defects in material and workmanship at the time of delivery to purchaser. Defective material may be returned to ARY, Inc. after inspection by an agent of ARY, Inc. and upon receipt from ARY, Inc. of shipping instructions specific to the defective Goods authorized by ARY, Inc. to be returned. ARY, Inc. at its sole option, may either (i) replace or repair any defective materials and workmanship (and return the Goods to purchaser without charge), (ii) refund the purchase price, or (iii) grant a reasonable allowance with the foregoing procedure.

This warranty is subject to the following limitations:

- i. ARY, Inc.'s responsibility and the purchaser's exclusive remedy under this warranty is limited to the repair or replacement of defects in material and workmanship, refund of the purchase price, or grant of a reasonable allowance on account of such defects, all as set forth above. ARY, Inc. is not responsible for any consequential damages resulting from the breach of this or any other express or implied warranty with respect to the Goods.
- ii. This express warranty is the only warranty applicable. It excludes all other express oral or written warranties and all warranties implied by law with respect to the Goods, including any warranties or merchantability or fitness for a particular purpose.
- iii. Every claim under this warranty shall be deemed waived by purchaser unless made in writing within one (1) year of the receipt of the Goods to which such claim relates.
- iv. This warranty, as to the Goods, is void (a) to repairs made by anyone other than ARY, Inc. without prior authorization from ARY, Inc., (b) to performance of any system of which ARY, Inc.'s Goods are a component part, (c) to deterioration by corrosion or any cause of failure other than defect of material or workmanship, (d) to any components of the Goods, including, without limitation, Teflon tape, lid gaskets and seal wire, or (e) if any of the Good or parts thereof have been tampered with or altered by someone other than ARY, Inc., or subjected to misuse, neglect, abuse, or misuse in application.

ARY, Inc.'s maximum liability hereunder, arising from any cause whatsoever, whether based in contract, tort (including negligence), strict liability, or any other theory of law, shall not exceed the purchase price. A suit based on any aforementioned cause of action must be commenced within one year from the date said action accrues.

Register your product and get technical support at:

www.vacmasterfresh.com/product-registration/
vacmasterfresh.com/contact-us/

A Product of

VACMASTER

P.O. Box 412888
Kansas City, MO 64141

VacMasterFresh.com

800.821.7849

All Rights Reserved. VacMaster® is a trademark or registered trademark of ARY, Inc.
in the United States and other countries.