

USER GUIDE

VACMASTER[®]

VP220

CHAMBER VACUUM SEALER



Welcome

Thank you for purchasing the **VacMaster® VP220 Chamber Vacuum Sealer**. You are about to use one of the most powerful vacuum sealers available. With the help of the VP220, you will now be able to keep food fresh for longer, deliver consistent portion control, and streamline your operations with programmable seal and vacuum time settings.

The VP220 is a chamber vacuum system, which offers two distinct advantages over non-chamber, external suction units. First, a much higher level of vacuum can be achieved, which means a longer shelf life for foods that you package. Secondly, liquids and liquid-rich foods can be effectively vacuum packaged. Foods like fresh meats, fish, soups, stews and marinated vegetables are packaged quickly with ease and no mess. The VacMaster® VP220 is perfect for storage, cook chill, portion control, sous vide, processing game and more.

For your safety and protection, carefully read and follow this guide. For more information, to Register your product or get support please visit us at VacMasterFresh.com

Contents

Safeguards.....	3
Tips.....	4
Features.....	5
Control Panel	6
How To.....	7
Troubleshooting	10
Cleaning and Storage	11
Vacuum Packaging Guidelines	12
Parts	13
Packaging Info.....	16
Specs.....	17
More Resources	18
Warranty and Registration.....	19
Notes.....	20

WARNING: When using electrical appliances, basic safety precautions should always be followed to reduce the risk of fire, electric shock, and/or injury to persons, including the following:

1. Read all instructions.

2. This appliance is not intended for use by persons with reduced physical, sensory, or mental capabilities, or lack of experience and knowledge, unless they are closely supervised and instructed concerning use of the appliance by a person responsible for their safety.

3. This appliance is not to be used by children. Close supervision is necessary when any appliance is used near children. Children should be supervised to ensure that they do not play with the appliance.

4. Never let the vacuum sealer run unattended. Disconnect the vacuum sealer from the power source before leaving the work area.

5. To protect against risk of electric shock, do not immerse cord, plug, or vacuum sealer in water or other liquid.

6. To reduce the risk of electric shock and injury to persons, disconnect from power supply when not in use, before cleaning and before servicing.

7. To provide continued protection against risk, do not operate any appliance with a damaged supply cord or plug, or after the appliance malfunctions or has been dropped or damaged in any manner. Supply cord replacement and repairs must be conducted by the manufacturer, its service agent, or similarly qualified persons in order to avoid a hazard. Call the provided customer service number for information on examination, repair, or adjustment.

8. The use of accessory attachments not recommended by the appliance manufacturer may cause injuries.

9. Do not use outdoors. Optimal operating temperature range is 65° to 75°.

10. Do not let cord hang over edge of table or counter, or touch hot surfaces, including stove.

11. Do not disassemble this appliance beyond instructions provided. Doing so may result in personal injury.

12. Do not place on or near a hot gas or electric burner, or in a heated oven.

13. Do not use for other than intended purpose.

14. This appliance is designed for a maximum vacuum ON time of 70 seconds and a minimum OFF time of 10 seconds between cycles. Stop the appliance and allow it to cool to ambient temperature if the appliance has been in use for 45 minutes.

15. This appliance is for commercial use only.

VP220 Important Tips

- Vacuum packaging is not a substitute for canning. All perishables still need to be refrigerated or frozen.
- Follow all food safety regulations as outlined by the FDA at www.FDA.gov.
- Use only VacMaster® Vacuum Chamber Pouches and accessories.
- Some fruits and vegetables may release gases, known as outgassing. When packaging these fruits and vegetables, outgassing can cause the vacuum to be gradually lost over time. Blanching or freezing before vacuum packaging helps prevent this from occurring.
- Delicate foods can be frozen prior to packaging to protect them from getting crushed by the vacuum.
- Use VacMaster® Bone Guards to cover an item's sharp edges to prevent pouch punctures.
- Allow foods and liquids to cool to room temperature before vacuum packaging.
- Avoid overfilling the pouch. Leave a minimum of 3" of space between the contents and the open end of the pouch. This is called head space. This will prevent spills during the vacuum sealing process.
- To prevent wrinkles from forming in the seal, gently stretch the pouch flat along the seal bar before closing the lid.
- VacMaster® pouches are boilable, freezable, and microwavable. When microwaving, it is important to pierce or make a small cut in the pouch.

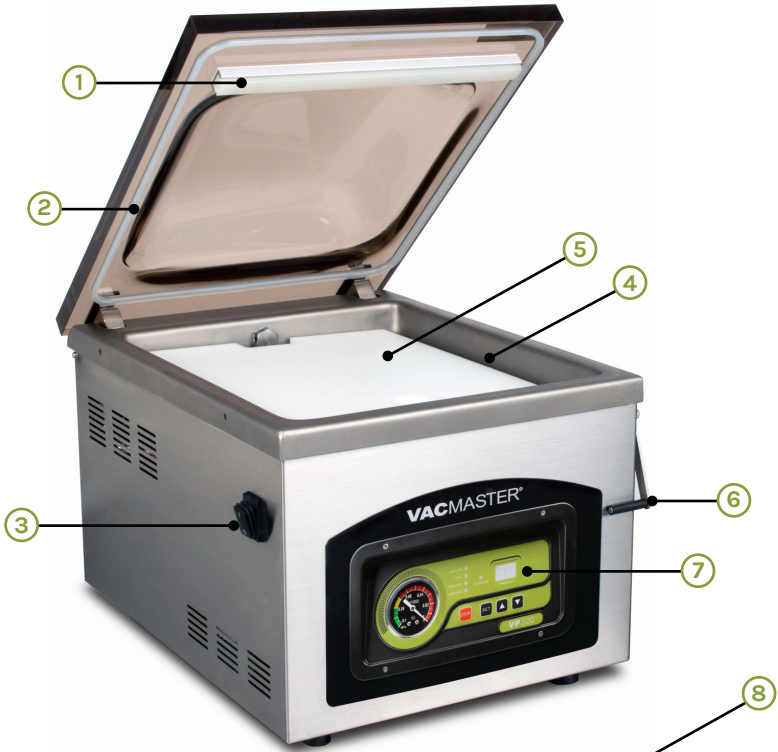

1. **Seal Pad**
2. **Lid Gasket**
3. **Power Switch**
4. **Vacuum Chamber**
5. **Filler Plates:** Used to occupy space in the chamber. The plates allow for faster vacuum. When more space is occupied, there is less air to be removed from the chamber.
6. **Lid Lock:** This feature is used to keep the lid closed while the machine is in storage. **DO NOT USE** while the machine is operating.
7. **Control Panel**
8. **Seal Bar**



VP220 Control Panel

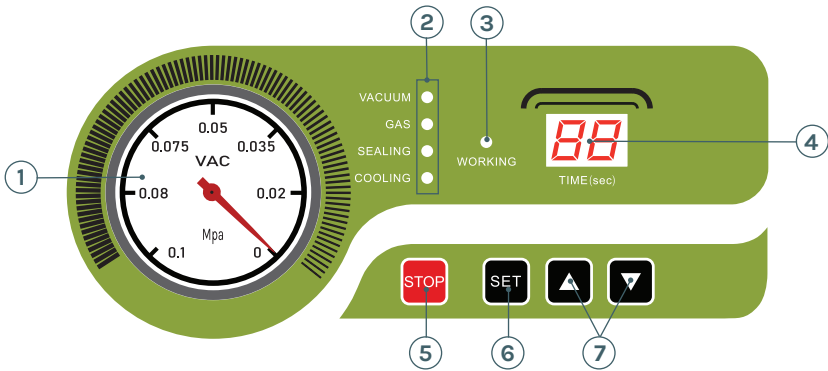

- 1. Vacuum Gauge** - Indicates the vacuum level inside the chamber.
- 2. Function Lights:**
 - Vacuum** - Illuminates to adjust vacuum time as well as during the vacuum process. During set up, adjust the vacuum time using the UP/DOWN Buttons.
 - Gas** - This model does not offer the gas flush option.
 - Sealing** - Illuminates to adjust vacuum time as well as during the sealing process. During set up, adjust the sealing time using the UP/DOWN Buttons.
 - Cooling** - Illuminates to adjust vacuum time as well as during the cooling process. During set up, adjust the cooling using the UP/DOWN buttons.
- 3. Working Indicator Light** - Illuminates to indicate the machine is in use.
- 4. LED Screen (Time)** - Displays current function or cycle time, measured in seconds.
- 5. STOP Button** - Press to stop the cycle and immediately seal the pouch. This button will only work when the machine is in the vacuum process.
- 6. SET Button** - Press to select the vacuum time, sealing time, or cooling time. Use with the UP/DOWN buttons.
- 7. UP/DOWN Buttons** - Press to increase or decrease vacuum time, sealing time, or cooling time.

Set Up - Powering up the VP220

1. Attach the power cord and plug the machine into a grounded electrical outlet - Properly insert the electrical cord into the power outlet on the back of the machine and then plug the cord into the wall outlet.
2. Open the machine lid - Release the lid lock, located on the right side of the machine, and allow the lid to lift and remain open.
3. Do not stand over the lid

IMPORTANT: DO NOT turn the machine on until the lid lock has been released, The lid lock feature is used **ONLY** to keep the lid closed while the machine is in storage.

4. To power ON press "I" on the power switch.
5. To power OFF, press "O" on the power switch.



Set Up - Adjusting the VP220 Timing Controls

NOTE: All timing adjustments must be made with the lid lock off and the lid open.

To adjust/set the timing controls, press the SET button on the control panel until the required label (Vacuum, Sealing or Cooling) is illuminated. For each selection, the current time setting will show on the LED Screen. All time settings are displayed in seconds.

For initial testing, the time settings should be:

- Vacuum Time** - 40 seconds
- Sealing Time** - 2 seconds
- Cooling Time** - 3 seconds

To change the settings, please read the instructions for each control on Page 6.

Set Up - Adjusting the VP220 Timing Controls

Vacuum Time: To increase or decrease the vacuum time, press the SET button until VACUUM is illuminated and then use the UP/DOWN buttons to adjust the vacuum time accordingly. The time setting will display on the LED Screen on the control panel.

NOTE: Filler plates can be used to reduce the vacuum time required. Place the filler plates inside the chamber as desired. Filler plates occupy space, leaving less air to be removed from the chamber. If you require more space inside the chamber, remove the filler plates to accommodate your product.

Sealing Time: To increase or decrease the sealing time, press the SET button until SEALING is illuminated and then use the UP/DOWN buttons to adjust the sealing time to accommodate your application. It is recommended that you make adjustments in 0.2 second increments to avoid melting the pouch.

NOTE: For thicker pouches, increase the seal time in 0.2 second increments until the pouch seals completely. In addition, for thinner pouches, decrease the seal time in 0.2 second increments to avoid over-sealing the pouch.

Cooling Time: To increase or decrease the cooling time, press the SET button until COOLING is illuminated and then use the UP/DOWN buttons to adjust the cooling time accordingly.

NOTE: The VP220 settings will always default to the most recently used settings on the machine.

TIP: To prolong the life of your seal bar, set the cooling time to twice the sealing time.

NOTE: After setting the timing controls, press the SET button until the function lights on the Control Panel are no longer illuminated. The machine will not start until all function lights are off.

1. Select a vacuum chamber pouch

Select the proper size of vacuum chamber pouch for the product that you are packaging. Make sure that the mouth of the pouch does not exceed the length of the seal bar and make sure the entire pouch fits inside the chamber. Allow 3" of extra headspace at the top of the pouch to ensure a quality, air-tight seal. The VP220 accepts vacuum chamber pouches up to 12"W x 15"L in size.

2. Fill the pouch and place inside the chamber

Fill the pouch with the product to be vacuum packaged and place the pouch inside the chamber. Keep pouches that contain liquids or wet product below the height of the seal bar. Lay the pouch flat inside the chamber, with the opening of the pouch across the seal bar. Make sure that the pouch lies flat across the seal bar and is free of wrinkles.

Note: The entire pouch, including the opening, must remain inside the chamber.

3. Close the machine lid to vacuum and seal

Close the lid and press down firmly for 2-3 seconds or until the vacuum gauge begins to move.

4. Inspect the pouch

When the lid opens, remove and inspect the pouch.

Vacuum confirmation - Check the quality of the vacuum by looking at the tightness of the pouch and the product. Look for air pockets or air leaks. If you notice that the product is not vacuum packaged tightly, then increase the vacuum time by 5 seconds, vacuum and seal again.

Seal confirmation - Inspect the pouch seal. A positive seal will appear clear upon inspection. If the seal is spotty or incomplete, increase the seal time by 0.1 second. If the seal appears white or milky, decrease the seal time by 0.1 second. Once the settings are determined for your application, vacuum and seal again. If the product is vacuumed and sealed tightly, then the process is complete.

5. ED Code - stands for end of demonstration. You are ready for a new cycle.

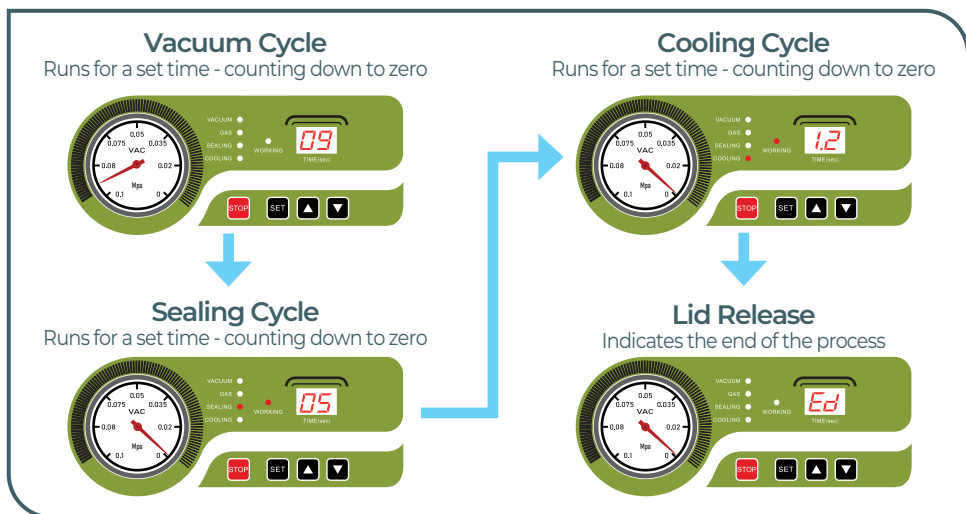

VP220 Troubleshooting

VP220 will not turn on -

- Make sure the machine is properly plugged into a grounded outlet.
- Check the power cord for tears and frays. Do not use this machine if the power cord is damaged.
- Make sure the power switch is turned on. The LED screen will be illuminated when on.
- If you see **'F1'** displayed on the LED screen and the machine will not function, make sure the lid is open and turn the power off. Turn the machine back on and it should return to working order.

VP220 does not pull a complete vacuum with pouch -

- The vacuum time may not be set high enough. Set the vacuum time higher and vacuum again.
- To vacuum and seal properly, the opening of the pouch must be within the vacuum chamber. For detailed instructions, refer to **"How To Use the VacMaster® VP220 Chamber Vacuum Sealer"**.
- The seal bar, lid gasket and vacuum pouch need to be clean, dry and free of debris for the vacuum process to be successful. Wipe surface of the seal bar, lid gasket and the inside of the pouch and try again.

Vacuum pouch loses vacuum after being sealed -

- Sharp items can poke small holes in pouches. To prevent this, cover sharp edges with VacMaster® Bone Guard and vacuum in a new pouch.
- Some fruits and vegetables can release gases (out gassing) if not properly blanched or frozen before packaging. Open the pouch. If you think food spoilage has begun, discard the food. If food spoilage has not yet begun, consume immediately. If in doubt, discard the food.

VP220 is not sealing pouch properly -

- The seal time may not be long enough. Increase the seal time and try again.
- Pouches will not seal if any moisture, food particles or debris are present in the seal area. Wipe the inside of the pouch clean and try again.
- Pouches must be properly placed along the seal bar. Make sure the entire pouch is over the seal bar and there are no wrinkles in the pouch material.

NOTE: High elevation may cause the gauge to not go all the way into the green. You may have to increase the vacuum time by 5-10 seconds in higher elevation.

If problems persist, contact Customer Service at
(800) 821-7849 or TechSupportARY@aryinc.com

- Disconnect the power cord from the electrical outlet by unplugging it. **DO NOT** disconnect by pulling on the cord.
- **DO NOT** immerse in water or spray directly with liquid.
- Check the Vacuum Chamber and Gasket, making sure they are clean and free of debris. If needed, use a clean, damp cloth with mild soap.
 - a. Wipe the vacuum chamber clean.
 - b. Wipe the gasket clean.
 - c. Wipe the seal area clean.
- **DO NOT** store the VP220 outside. 65° to 75° recommended.
- **DO NOT** use any acetone-based or abrasive cleaners on the lid or other plastic parts. Only clean lid with a damp cloth and mild soap.

Maintenance Kit

1. **Double-Sided Tape:** Used for adhering the top bar that holds the seal pad in the lid.
2. **10-AMP Fuses (2x):** Used for replacing fuses located in the cord receptacle. NSF models will have a fuse on the seal transformer.
3. **Seal Wire:** Used to replace seal wire that spans the length of the seal bar; should be replaced if the wire shows heavy discoloration.
4. **Seal Tape:** Used to replace seal tape the covers the seal wires; should be replaced if the tape shows heavy discoloration, is torn, or is starting to lose the adhesive.
5. **Hex/Allen Wrench:** Used to remove tension blocks that hold the seal wire to the base of the seal bar.
6. **Reversible Screwdriver:** Used to un-thread screws on the cabinet of the machine and the screws to move the chamber.



VP220 Vacuum Packaging Guidelines

- Follow all food safety regulations as outlined by the FDA at www.FDA.gov.
- Vacuum packaging is NOT a substitute for canning.
- Vacuum packaging cannot reverse the deterioration of foods.
- Vacuum packaging is NOT a substitute for refrigeration or freezing.
- Some fruits and vegetables may release gases, known as outgassing. When packaging these fruits and vegetables, outgassing can cause the vacuum to be gradually lost over time. Blanching or freezing before vacuum packaging helps prevent this from occurring.

NOTE: Due to the risk of anaerobic bacteria, soft cheeses, fresh mushrooms, garlic and onions should never be vacuum packaged.

- It is critical that food handling and storage are maintained at low temperatures. You can reduce the growth of microorganisms at temperatures of 34°F or less. Freezing at 0°F will not kill microorganisms, but reduces the chances of them growing. For long-term food storage, always freeze foods that have been vacuumed packaged.

NOTE: Beef and other proteins may look darker after being vacuum packaged. This is due to the removal of oxygen and is not an indication of spoilage.

- All perishable foods must be refrigerated or frozen.

LID ASSEMBLY

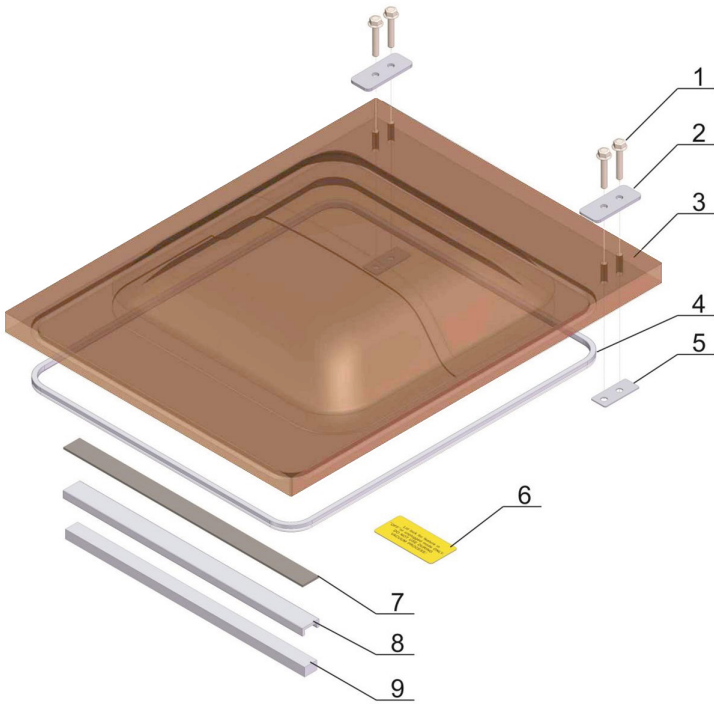

Part #	Part Name	Qty
1	Hex head flange bolts	4
2	Press plate on organic cover	2
3	979000 Lid	1
4	979220 Lid Gasket	1
	978263 Lid Gasket	7 ft
5	Lower pressure plate of the organic cover	2
6	Sticker	1
7	979825 Tape, top bar	1 roll
8	979451 Top bar	1
9	979452 Seal Pad	1

CHAMBER ASSEMBLY

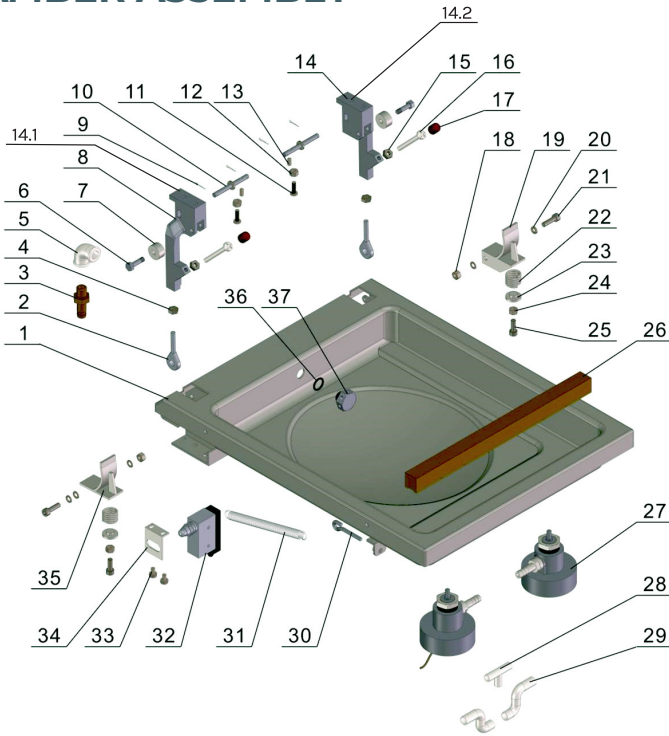

Part #	Part Name	Qty	Part #	Part Name	Qty
1	Studio components	1	20	Standard spring washers	2
2	Joint bearing	2	21	Hex socket head cap screw	2
3	Piston pump connector	1	22	Damping spring	2
4	Hex nuts - Grade C	2	23	Pressure regulator plate	2
5	Right angle fittings	1	24	Hex nuts - Grade C	2
6	Damper axle	2	25	Hex socket head cap screw	2
7	Damper wheel	2	26	979458 Seal Bar Assembly	1
8	Hinge set - see 2-14.1 & 2-14.2	2	27	979459 Piston assembly, large	2
9	Cotter Pin	4	28	979254 Tee, Piston Hose	1
10	979455 Hinge Pin	2	29	979156 Hose, solenoid valve (for gauge/pistons)	40
11	Cross recessed pan head screw type H	2	30	Tension spring adjustment lever	2
12	Hex nuts - Grade C	2	31	Open cover spring	2
13	Hexagon socket flat point set screws	2	32	979460 Microswitch	1
14.1	979453 Left Hinge	1	33	Cross recessed pan head triple combination screws	2
14.2	979454 Right Hinge	1	34	979354A Bracket, proximity switch	1
15 - 17	Hinge Set	1	35	979456 Plate assembly, Right	1
18	Hex nuts - Grade C	2	36	O-ring rubber seal	1
19	979457 Plate assembly, left	1	37	Extraction joint	1

MACHINE HULL

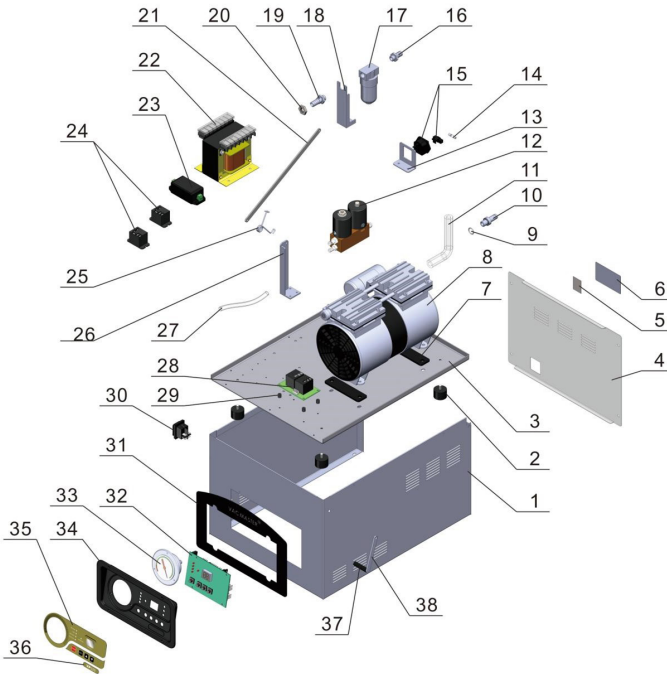

Part #	Part Name	Qty	Part #	Part Name	Qty	
1	Chassis	1	22	979464	Transformer, sealing	
2	979461	Foot, rubber	4	23	979465	Module, Power
3	Bottom plate	1	24	979466	Relay, control	
4	Back cover	1	25		Strut torsion spring	
5	Sticker	1	26		Mount	
6	Stainless stell nameplate	1	27	979156	Hose, solenoid valve (for gauge/pistons)	
7	Piston pump rubber pad	2	28	979467	Relay timer	
8	979232	Oil - free pump	1	29	980100	Relay spacer
9	O-ring rubber seal	1	30	979468	Power switch	
10	Piston pump connector	1	31	979130	Front Decal, VacMaster Panel	
11	979157	Hose, vacuum pump	36 in	32	979469	Main board
12	979450	Solenoid valve	1	33	979126	Vacuum gauge
13	Power plug in bracket / socket mount	1	34	979125	Instrument Panel	
14	Fuse, 10A	2	35	979928	Stickers, Green Panel decal stickers (non-programmable)	
15	979463	Plug, socket	1	36	979931	Sticker, single green panel decal
16 - 20	979144	Filter, Air Inlet	1	37	979172	Lid latch assembly
21	Strut	1	38		Organic cover buckle	

VP220 Packaging Information

With the VP220, you can easily package a wide variety of sizes and shapes. You can also prep and store smaller individual serving portions as well as bulk items.

- Keeps food fresh 3-5 times longer than conventional storage bags.
- Several sizes available to meet your packaging needs.
- Terrific for hundreds of applications in and out of the kitchen.
- Safe for freezer, refrigeration, and microwave use.
- Re-Therm pouches are reinforced to be able to handle being boiled for up to 30 minutes. The other bags can be boiled, but not for that long without being compromised. When a normal bag becomes compromised, the pouch will begin to delaminate.
- Bag thickness available in standard 3mil or heavy duty 4mil.
- Bags are economically priced, giving you a better value.

The chamber of the VP220 can easily vacuum package the following sizes of vacuum pouches:

ITEM #	DESCRIPTION	#	ITEM #	DESCRIPTION	#
30765	2.5" X 10" Vacuum Chamber Pouches 3-Mil 2000/Box	4x	40731	10 X 8 Horizontal Vacuum Chamber Pouches 3-Mil 250/Box	1x
30766	6" X 7" Vacuum Chamber Pouches 3-Mil - 1000/Box	2x	30724	10" X 10" Vacuum Chamber Pouches 3-Mil 1000/Box	1x
30742	6" X 8" Vacuum Chamber Pouches 3-Mil - 1000/Box	2x	50724	10 X 12 Zipper Vacuum Chamber Pouches 3-Mil 1000/Box	1x
30608	6" X 8" Vacuum Chamber Pouches 4-Mil - 1000/Box	2x	30620	10 X 12 Vacuum Chamber Pouches 4-Mil 1000/Box	1x
30720	6" X 8.5" Vacuum Chamber Pouches 3-Mil - 1000 /Box	2x	40725	10" X 13" Pouches 3-Mil Vacuum Chamber Pouches 250/Box	1x
30750	6" X 8.5" Re-Therm Vacuum Chamber Pouches 3-Mil 1- 000/Box	2x	30725	10" X 13" Vacuum Chamber Pouches 3-Mil 1000/Box	1x
30721	6" X 10" Vacuum Chamber Pouches 3-Mil - 1000/Box	2x	30778	10" X 13" Vacuum Chamber Pouches 4-Mil 1000/Box	1x
30610	6" X 10" Vacuum Chamber Pouches 4-Mil - 1000/Box	2x	30776	10 X 13 Vacuum Chamber Pouches 5-Mil 1000/Box	1x
50717	6" X 10" Zipper Vacuum Chamber Pouches 3-Mil - 1000/Box	2x	30726	10" X 15" Vacuum Chamber Pouches 3-Mil 1000/Box	1x
40721	6" X 12" Pouches 3-Mil Flat Vacuum Chamber Pouches - 500/Box	2x	30749	10 X 15 Re-Therm Vacuum Chamber Pouches 3-Mil 1000/Box	1x
30743	6" X 12" Vacuum Chamber Pouches 3-Mil - 1000/Box	2x	50721	10 X 15 Zipper Vacuum Chamber Pouches 3-Mil 1000/Box	1x
30612	6" X 12" Vacuum Chamber Pouches 4-Mil - 1000/Box	2x	40726	11.5 X 13 Vacuum Chamber Pouches 3-Mil 250/Box	1x
50718	6" X 12" Zipper Vacuum Chamber Pouches 3-Mil - 1000/Box	2x	40732	12 X 8 Horizontal Vacuum Chamber Pouches 3-Mil 250/Box	1x
30788	7 X 9 Vacuum Chamber Pouches 3-Mil 1000/Box	1x	40733	12 X 10 Horizontal Vacuum Chamber Pouches 3-Mil 250/Box	1x
30789	7 X 11 Vacuum Chamber Pouches 3-Mil 1000/Box	1x	30727	12" X 12" Vacuum Chamber Pouches 3-Mil 1000/Box	1x
30791	7 X 12 Vacuum Chamber Pouches 3-Mil 1000/Box	1x	40728	12 X 14 Vacuum Chamber Pouches 3-Mil 250/Box	1x
40722	8" X 10" Pouches 3-Mil Flat Vacuum Chamber Pouches 500/Box	1x	30728	12" X 14" Vacuum Chamber Pouches 3-Mil 1000/Box	1x
30722	8" X 10" Vacuum Chamber Pouches 3-Mil 1000/Box	1x	30624	12 X 14 Vacuum Chamber Pouches 4-Mil 1000/Box	1x
30614	8 X 10 Vacuum Chamber Pouches 4-Mil 1000/Box	1x	50726	12 X 14 Zipper Vacuum Chamber Pouches 3-Mil 1000/Box	1x
50719	8 X 10 Zipper Vacuum Chamber Pouches 3-Mil 1000/Box	1x	30746	12" X 15" Vacuum Chamber Pouches 3-Mil 500/Box	1x
30723	8" X 12" Vacuum Chamber Pouches 3-Mil 1 000/Box	1x			
40751	8 X 12 Re-Therm Vacuum Chamber Pouches 3-Mil 1000/Box	1x			
30754	8 X 12 Vacuum Chamber Pouches 4-Mil 1000/Box	1x			
50720	8 X 12 Zipper Vacuum Chamber Pouches 3-Mil 1000/Box	1x			
30744	8" X 15" Vacuum Chamber Pouches 3-Mil 1000/Box	1x			
30618	8 X 15 Vacuum Chamber Pouches 4-Mil 1000/Box	1x			
30777	9 X 12 Vacuum Chamber Pouches 3-Mil 1000/Box	1x			

SKU:	Machine Type:	Chamber Size:
VP220	Tabletop Chamber	12.5" x 15" x 5"
Seal Bar Length:	Vacuum Pump:	Cycle Time:
12.25"	1/4 HP Heavy-duty maintenance free dry pump	20 - 99 Seconds
Electrical Specs:	Machine Dimensions	Weight:
Single phase 110v 10 AMP	15.5" x 19" x 15.75"	82 lbs
Maximum Bag/ Pouch Size:	Compatible Bags/ Pouches:	
12" x 15"	Chamber Vacuum Sealer Pouches	

Includes:

- 60 Assorted Vacuum Chamber Pouches
- 1 Filler Plate
- Maintenance Kit
- User's Guide

Want Recipes, Tips and Videos?

Check out our Blog or find us on Online!



Check out our Blog:

vacmasterfresh.com/fresh-bites-blog/

Check out our  YouTube Channel:

youtube.com/@VacMasterFresh

Or Find Us On Social:



<https://www.facebook.com/vacmasterfresh>



<https://twitter.com/VacMasterFresh>



<https://www.instagram.com/vacmasterfresh>

ARY, Inc., a distributor and manufacturer of vacuum packaging and other machines (collectively, the "Goods"), extends to the purchaser of the Goods a Limited One Year Warranty, from the receipt of the Goods, under terms and conditions set out herein.

All Goods sold by ARY, Inc. are warranted to be free from defects in material and workmanship at the time of delivery to purchaser. Defective material may be returned to ARY, Inc. after inspection by an agent of ARY, Inc. and upon receipt from ARY, Inc. of shipping instructions specific to the defective Goods authorized by ARY, Inc. to be returned. ARY, Inc. at its sole option, may either (i) replace or repair any defective materials and workmanship (and return the Goods to purchaser without charge), (ii) refund the purchase price, or (iii) grant a reasonable allowance with the foregoing procedure.

This warranty is subject to the following limitations:

- i. ARY, Inc.'s responsibility and the purchaser's exclusive remedy under this warranty is limited to the repair or replacement of defects in material and workmanship, refund of the purchase price, or grant of a reasonable allowance on account of such defects, all as set forth above. ARY, Inc. is not responsible for any consequential damages resulting from the breach of this or any other express or implied warranty with respect to the Goods.
- ii. This express warranty is the only warranty applicable. It excludes all other express oral or written warranties and all warranties implied by law with respect to the Goods, including any warranties or merchantability or fitness for a particular purpose.
- iii. Every claim under this warranty shall be deemed waived by purchaser unless made in writing within one (1) year of the receipt of the Goods to which such claim relates.
- iv. This warranty, as to the Goods, is void (a) to repairs made by anyone other than ARY, Inc. without prior authorization from ARY, Inc., (b) to performance of any system of which ARY, Inc.'s Goods are a component part, (c) to deterioration by corrosion or any cause of failure other than defect of material or workmanship, (d) to any components of the Goods, including, without limitation, Teflon tape, lid gaskets and seal wire, or (e) if any of the Good or parts thereof have been tampered with or altered by someone other than ARY, Inc., or subjected to misuse, neglect, abuse, or misuse in application.

ARY, Inc.'s maximum liability hereunder, arising from any cause whatsoever, whether based in contract, tort (including negligence), strict liability, or any other theory of law, shall not exceed the purchase price. A suit based on any aforementioned cause of action must be commenced within one year from the date said action accrues.

Register your product and get technical support at:

www.vacmasterfresh.com/product-registration/
vacmasterfresh.com/contact-us/

VACMASTER VP220 Chamber Vacuum Sealer | User Guide

A Product of

VACMASTER

P.O. Box 412888
Kansas City, MO 64141

VacMasterFresh.com

800.821.7849

All Rights Reserved. VacMaster® is a trademark or registered trademark of ARY, Inc.
in the United States and other countries.