



# **XEB SERIES 3**

## Gas-Fired Hot Water Induced Draft Boilers

### **Models**

- XEB-2
- XEB-3
- XEB-4
- XEB-5
- XEB-6

## **REPAIR PARTS & OPTIONAL KITS**

#### Ordering Instructions

Order Parts through your nearest supplier.

When ordering parts, obtain Model Number and Serial from data plate on your boiler.

Include following information when ordering.

Part Number \_\_\_\_\_

Part Description \_\_\_\_\_

Boiler Model Number \_\_\_\_\_

Boiler Serial Number \_\_\_\_\_



Manufactured by:  
ECR International Inc.  
2201 Dwyer Avenue, Utica, NY 13501  
Tel. 800 253 7900  
[www.ecrinternational.com](http://www.ecrinternational.com)  
PN 240013100 REV. A [08/15/2020]

# TABLE OF CONTENTS

<b>Table of Contents</b>	<b>Page(s)</b>
Jacket, Base & Sheet Metal	4 & 5
Control Assembly	6
Piping Repair Parts	7
Natural Gas Burner & Manifold	8
Propane Gas Burner & Manifold	9
Heat Exchanger Block & Insulation	10
Conversion Kits	11

# BOILER EXPLODED VIEW

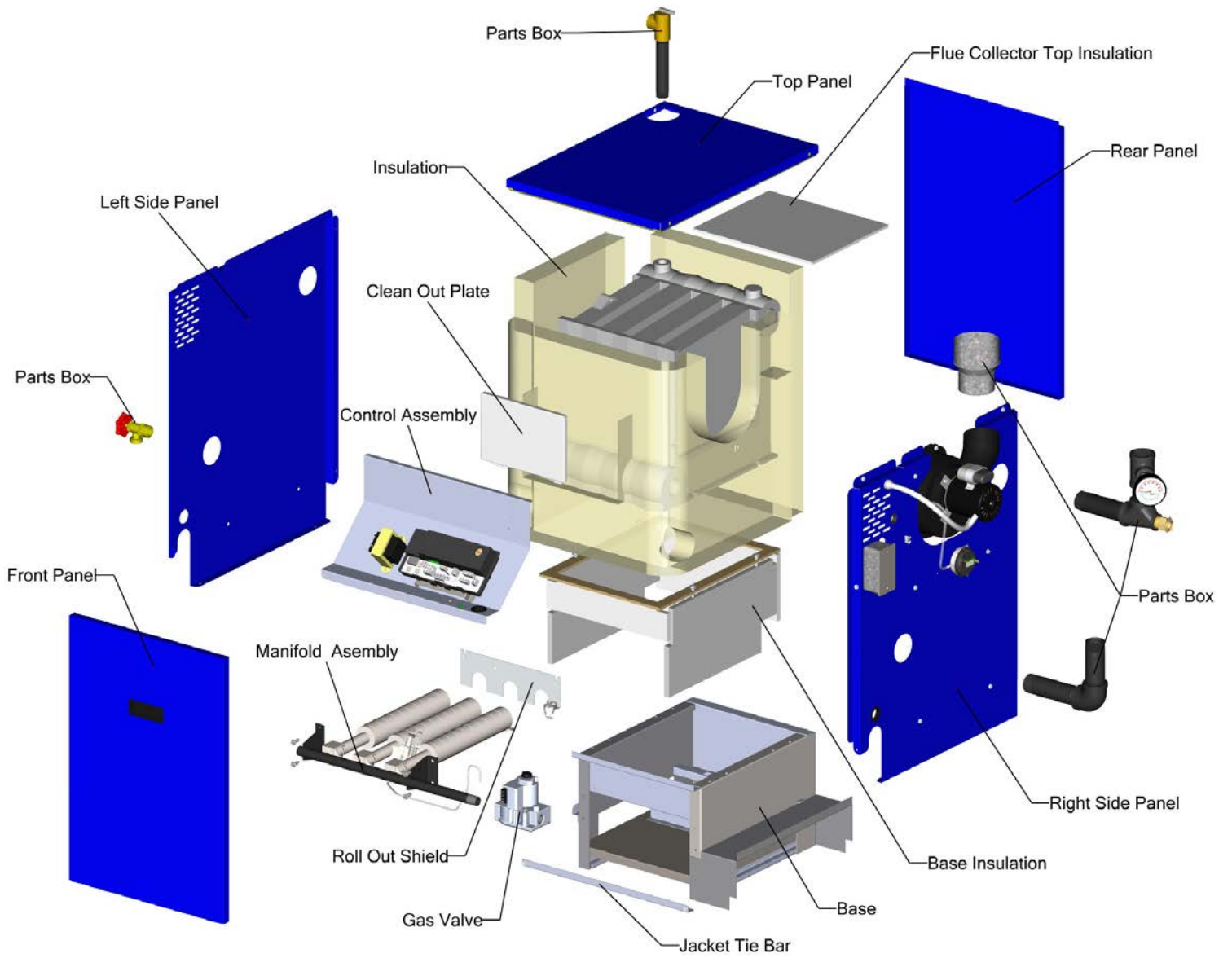

# JACKET, BASE, & SHEET METAL

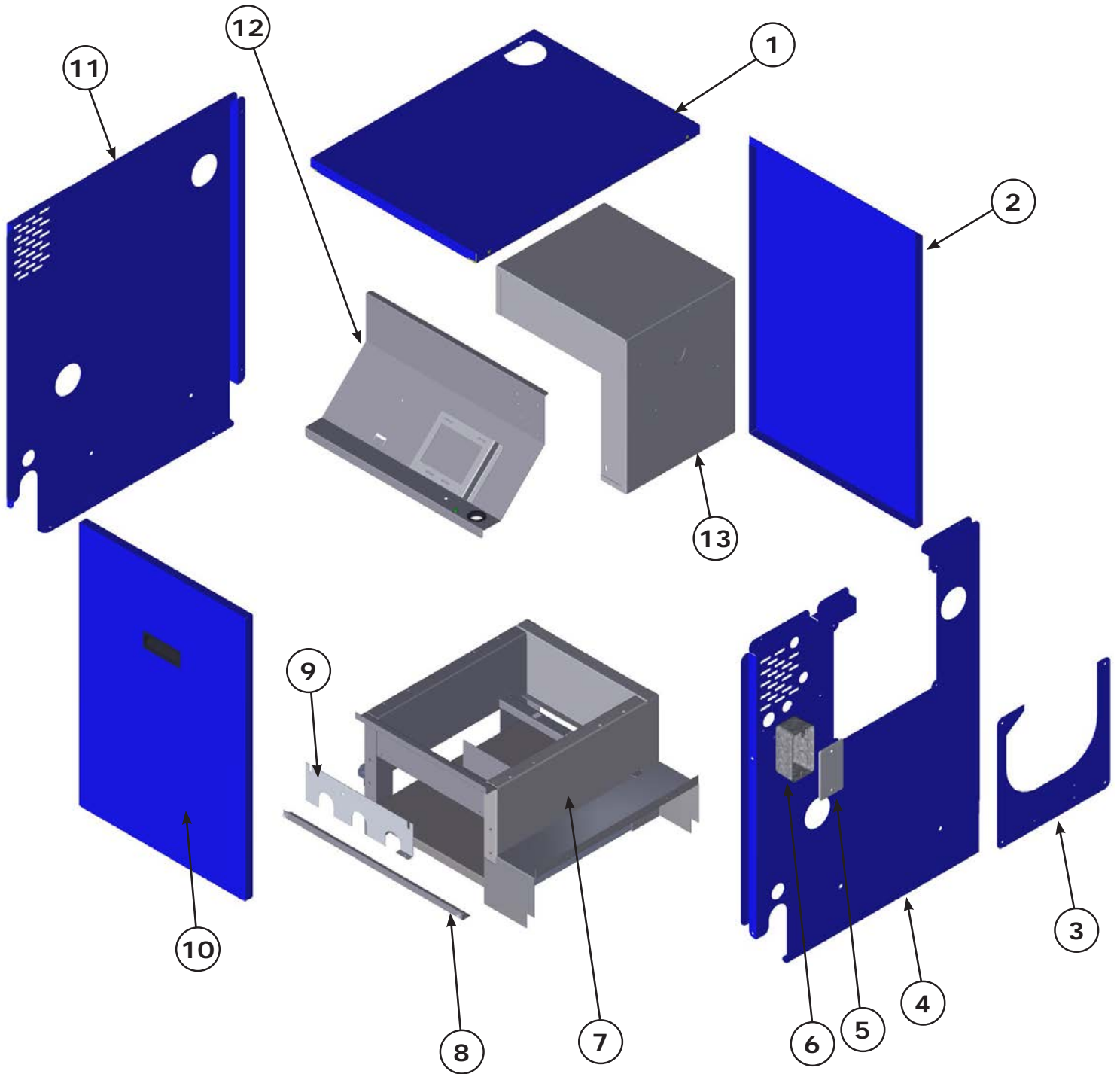

# JACKET, BASE, & SHEET METAL

ITEM	PART NO.	DESCRIPTION	QTY.
1	550003967	Jacket, Top Panel (2 Sec.)	1
	550003968	Jacket, Top Panel (3 Sec.)	
	550003969	Jacket, Top Panel (4 Sec.)	
	550003970	Jacket, Top Panel (5 Sec.)	
	550003971	Jacket, Top Panel (6 Sec.)	
2	630001022AC	Jacket, Back Panel (2 Sec.)	1
	630001023AC	Jacket, Back Panel (3 Sec.)	
	630001024AC	Jacket, Back Panel (4 Sec.)	
	630001025AC	Jacket, Back Panel (5 Sec.)	
	630001026AC	Jacket, Back Panel (6 Sec.)	
3	630001170AC	Blower Cover Plate	1
4	550004027	Jacket, Right Side Panel	1
5	212000017	Junction Box, 2" x 4"	1
6	212000018	Junction Box Cover, 2" x 4"	1
7	42500733	Boiler Base (2 Sec.)	1
	42500734	Boiler Base (3 Sec.)	
	42500735	Boiler Base (4 Sec.)	
	42500736	Boiler Base (5 Sec.)	
	42500737	Boiler Base (6 Sec.)	
8	42500653	Jacket Tie Bar (2 Sec.)	1
	42500654	Jacket Tie Bar (3 Sec.)	
	42500655	Jacket Tie Bar (4 Sec.)	
	42500656	Jacket Tie Bar (5 Sec.)	
	42500657	Jacket Tie Bar (6 Sec.)	
9	42500932	Roll out Shield (2 Sec.)	1
	42500933	Roll out Shield (3 Sec.)	
	42500934	Roll out Shield (4 Sec.)	
	42500935	Roll out Shield (5 Sec.)	
	42500936	Roll out Shield (6 Sec.)	

ITEM	PART NO.	DESCRIPTION	QTY.
10	550003992	Service Door (2 Sec.)	1
	550003993	Service Door (3 Sec.)	
	550003994	Service Door (4 Sec.)	
	550003995	Service Door (5 Sec.)	
	550003996	Service Door (6 Sec.)	
11	550004032	Jacket, Left Side Panel	1
12	109008500-1	Control Panel (2 Sec.)	1
	109008501-1	Control Panel (3 Sec.)	
	109008502-1	Control Panel (4 Sec.)	
	109008503-1	Control Panel (5 Sec.)	
	109008504-1	Control Panel (6 Sec.)	
13	730003002	Flue Collector (2 Sec.)	1
	730003003	Flue Collector (3 Sec.)	
	730003004	Flue Collector (4 Sec.)	
	3002619	Flue Collector (5 Sec.)	
	3002620	Flue Collector (6 Sec.)	
‡	550004036	Jacket, Complete (2 Sec.) Includes Items 1, 2, 3, 4, 8, 10, & 11	1
	550004037	Jacket, Complete (3 Sec.) Includes Items 1, 2, 3, 4, 8, 10, & 11	
	550004038	Jacket, Complete (4 Sec.) Includes Items 1, 2, 3, 4, 8, 10, & 11	
	550004039	Jacket, Complete (5 Sec.) Includes Items 1, 2, 3, 4, 8, 10, & 11	
	550004040	Jacket, Complete (6 Sec.) Includes Items 1, 2, 3, 4, 8, 10, & 11	
‡	14695074	#10 x 1/2 Sheet Metal Screw	22

‡ Not illustrated

# CONTROL ASSEMBLY

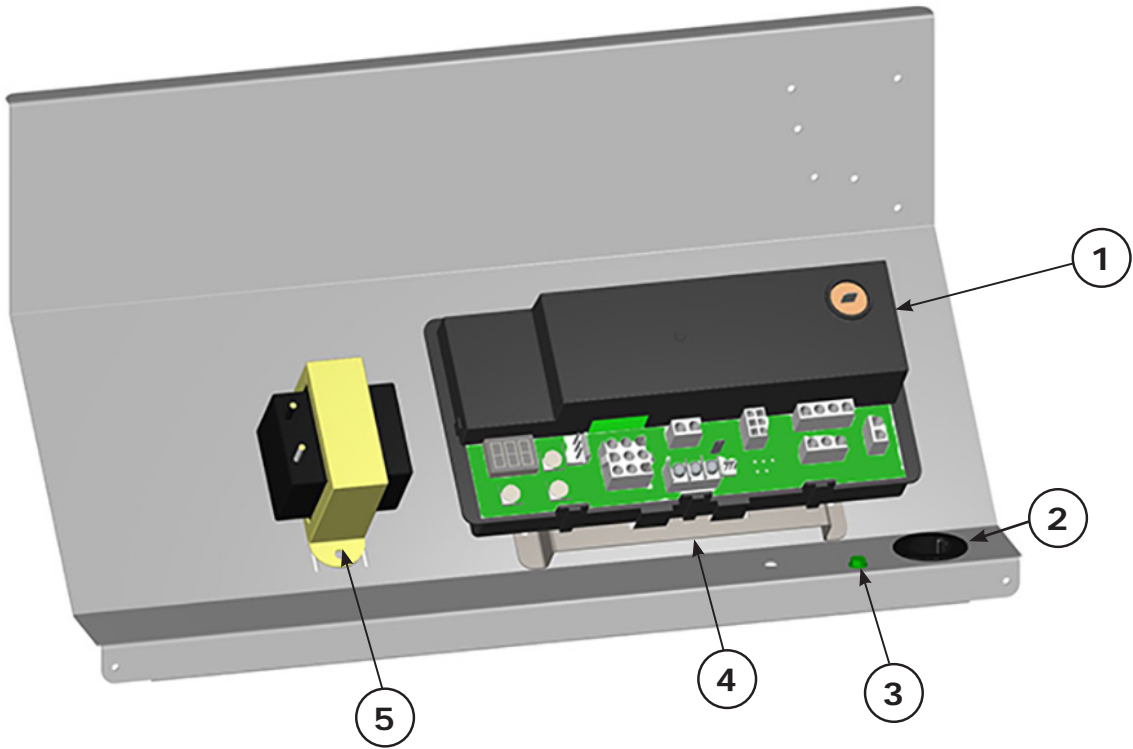

ITEM	PART NO.	DESCRIPTION	QTY.
1	<a href="#">240009241</a>	Control	1
2	<a href="#">206000025</a>	Grommet	1
3	<a href="#">HW07701</a>	Ground Screw #8	1
4	<a href="#">109008496</a>	Control Standoff	1
5	<a href="#">240008782</a>	Transformer	1
‡	<a href="#">240009194</a>	Line Voltage Harness	1
‡	<a href="#">240009342</a>	Low Voltage Wire Harness	1
‡	<a href="#">240008767</a>	Circulator Harness	1
‡ Not illustrated			

# PIPING REPAIR PARTS

ITEM	PART NO.	DESCRIPTION
1	14622011	¾" ASME Relief Valve
2	1310010	Nipple ¾" x 5½"
3	1260006SP	Temperature Pressure Gauge (3½" Stem)
4	1060002	Bushing ¾" x ¼"
5	PF05901	Tee 1¼" x ¾" x 1¼"
6	14607044	Nipple 1¼" x 2½"
7	1635001	Well
8	1510001	Tee 1¼" x ¾" x 1¼"
9	14607019	Nipple 1¼" x 5½"
10	240009011	Induced Draft Blower and Gasket
11	240013045	Pressure Switch - 2,3,4,5 Section
	240013044	Pressure Switch - 6 Section
12	14607017	Nipple 1¼" x 6"
13	1190002	Elbow 1¼"
14	1310002	Nipple 1¼" x 4½"
‡	240007732	Sensor
‡	240008013	Sensor Clip
‡	1552014	Silicone Tube 12" Long (Blower to Pressure Switch)
‡	14629002	Roll out and Blocked Vent Switch
‡	14628012	3" x 4" Increaser Fitting - Galvanized
‡	240009323	Drain Valve
‡ Not illustrated		

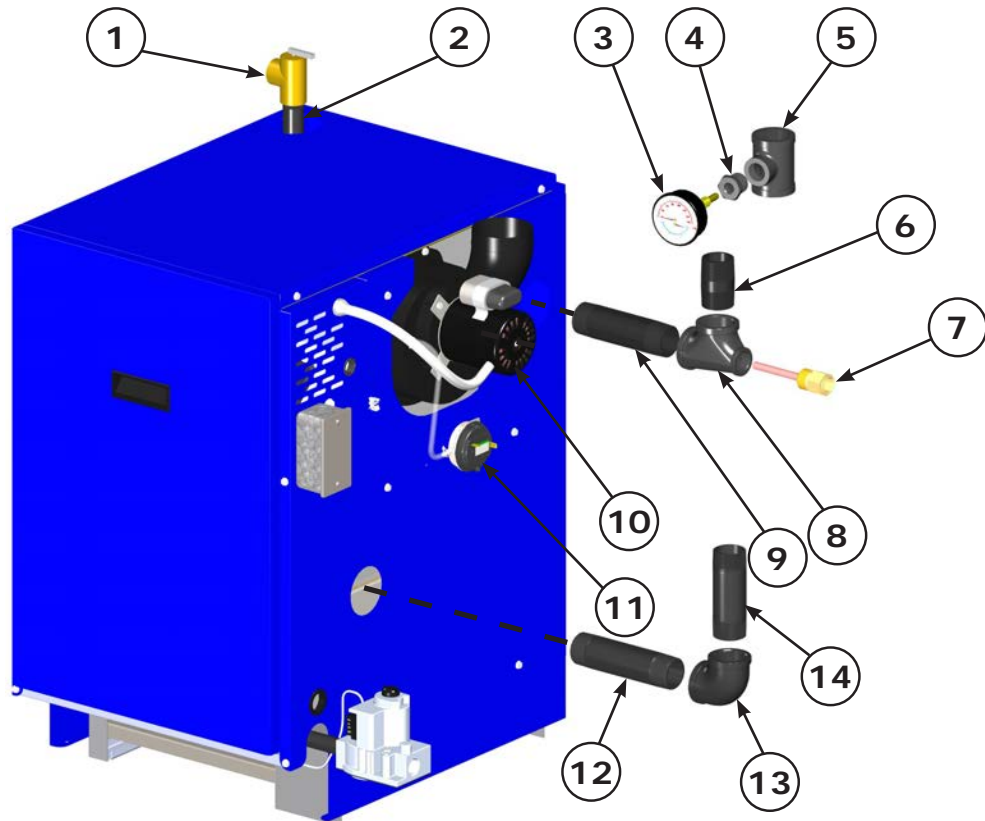

# BURNER & MANIFOLD

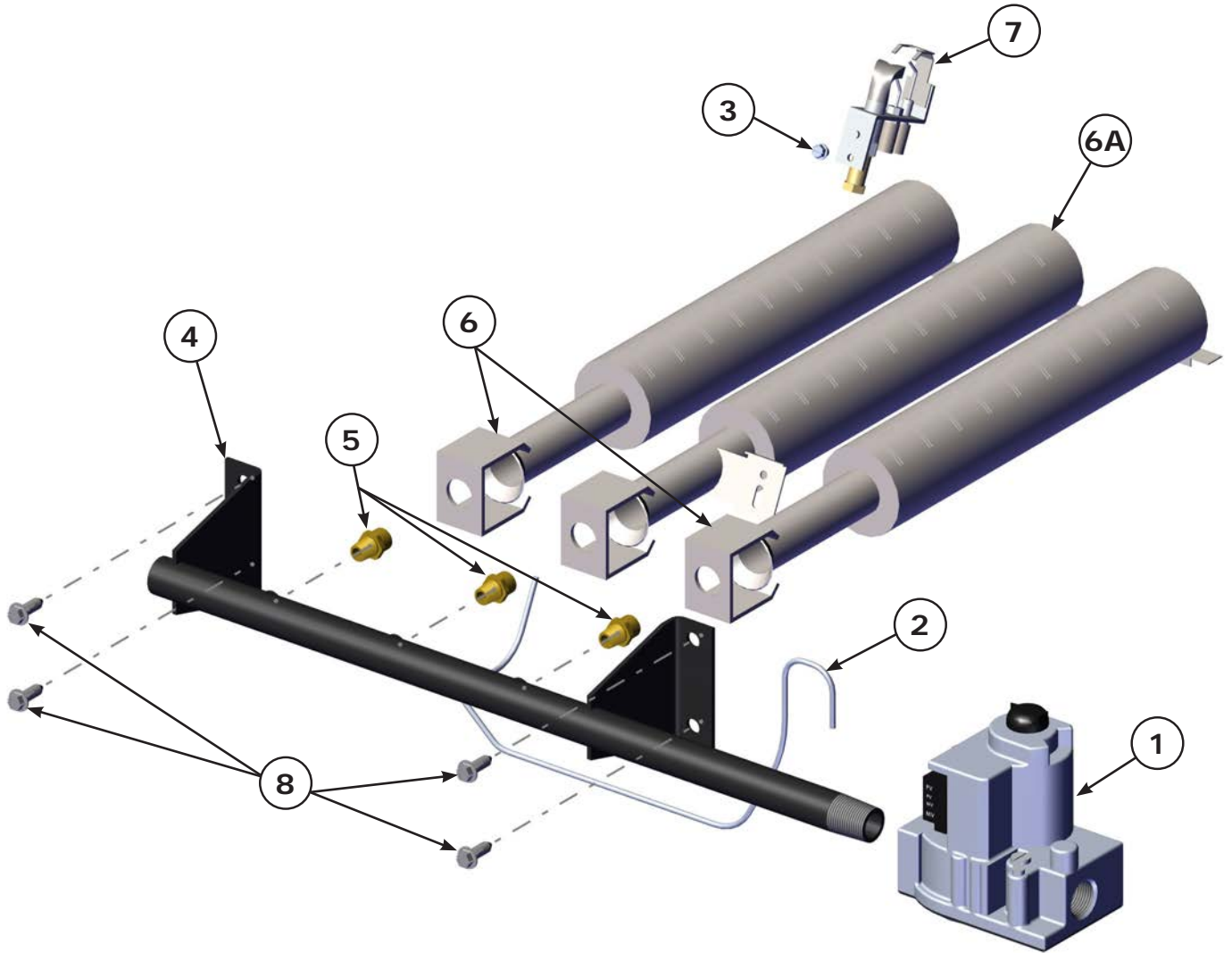

NOTE: Actual gas valve may look different than gas valve shown.

# BURNER & MANIFOLD

ITEM	PART NO.	DESCRIPTION	QTY.
1	14662052	Gas Valve, <b>Natural Gas</b> (2-5 Sec.)	1
	14662058	Gas Valve, <b>Natural Gas</b> (6 Sec.)	
	550002740	Gas Valve, <b>Propane Gas</b> (2-5 Sec.)	
	550002259	Gas Valve, <b>Propane Gas</b> (6 Sec.)	
2	43300201	Pilot Tube With Fitting (2-5 Sec.)	1
	43300200	Pilot Tube With Fitting (6 Sec.)	
3	14695301	10-32 x 3/16" Slotted Hex Head Screws	1
4	14616042	Gas Manifold (2 Sec.)	1
	14616043	Gas Manifold (3 Sec.)	
	14616044	Gas Manifold (4 Sec.)	
	14616045	Gas Manifold (5 Sec.)	
	14616024	Gas Manifold (6 Sec.)	
5	240012903	Orifice - <b>Natural Gas</b> (2 Sec.)	1
	240012905	Orifice - <b>Natural Gas</b> (3 Sec.)	2
		Orifice - <b>Natural Gas</b> (4 Sec.)	3
		Orifice - <b>Natural Gas</b> (5 Sec.)	4
	240013128	Orifice - <b>Natural Gas</b> (6 Sec.)	5
5	240012917	Orifice - <b>Propane Gas</b> (2 Sec.)	1
	240012918	Orifice - <b>Propane Gas</b> (3 Sec.)	2
		Orifice - <b>Propane Gas</b> (4 Sec.)	3
		Orifice - <b>Propane Gas</b> (5 Sec.)	4
	240013144	Orifice - <b>Propane Gas</b> (6 Sec.)	5
6	14615532	Main Burner Less Pilot Bracket (3 Sec.)	1
		Main Burner Less Pilot Bracket (4 Sec.)	2
		Main Burner Less Pilot Bracket (5 Sec.)	3
		Main Burner Less Pilot Bracket (6 Sec.)	4
6A	14615531	Main Burner with Pilot Bracket (3-6 Sec.)	1
7	240009031	Pilot with Orifice, <b>Natural Gas</b>	1
8	14695070	14 x 3/4 Slotted Hex Head Screw	4
‡	PB00208	Pilot Orifice, <b>Propane Gas</b>	1

‡ Not illustrated pilot sold only in natural gas, must field convert.

# HEAT EXCHANGER BLOCK AND INSULATION

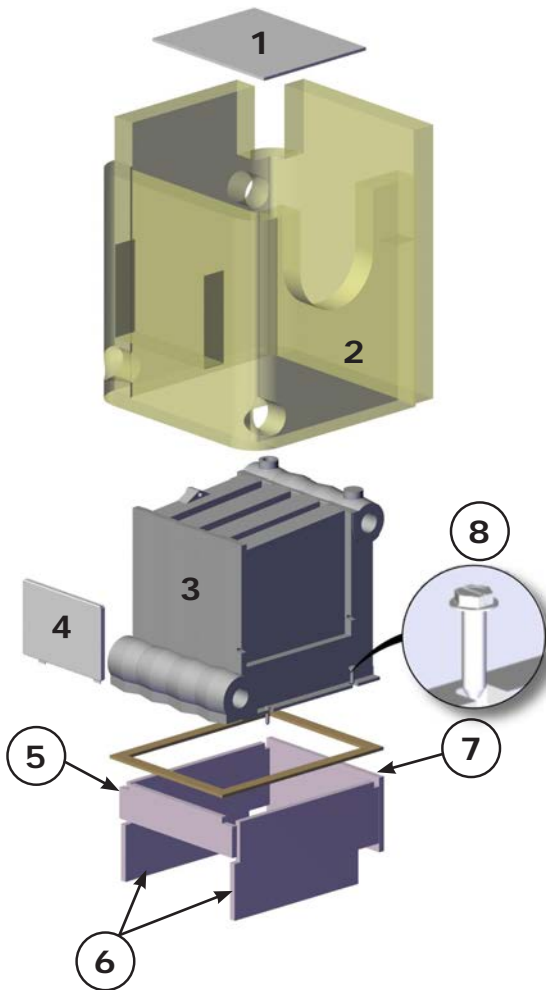

When evaluating HTEX block replacement, please review insulation parts if needed.

ITEM	PART NO.	DESCRIPTION	QTY.
1	14614021	Flue Collector Top Insulation (2 Sec.)	1
	14614022	Flue Collector Top Insulation (3 Sec.)	1
	14614023	Flue Collector Top Insulation (4 Sec.)	1
	14614024	Flue Collector Top Insulation (5 Sec.)	1
	14614025	Flue Collector Top Insulation (6 Sec.)	1
2	240012937	Heat Exchanger Block Insulation Wrap (2 Sec.)	1
	240012938	Heat Exchanger Block Insulation Wrap (3 Sec.)	1
	240012939	Heat Exchanger Block Insulation Wrap (4 Sec.)	1
	240012940 & 240012942	Heat Exchanger Block Insulation Wrap (5 Sec.)	1
	240012941 & 240012942	Heat Exchanger Block Insulation Wrap (6 Sec.)	1
3	41000212	Tested Block 2 Section	1
	41000312	Tested Block 3 Section	1
	41000412	Tested Block 4 Section	1
	41000512	Tested Block 5 Section	1
	41000612	Tested Block 6 Section	1
4	42501539	Clean out Plate(s) & Insulation (2 Sec.)	1
	42501540	Clean out Plate(s) & Insulation (3 Sec.)	1
	42501541	Clean out Plate(s) & Insulation (4 Sec.)	1
	42501542	Clean out Plate(s) & Insulation (5 Sec.)	1
	42501540 & 42501541	Clean out Plate(s) & Insulation (6 Sec.)	1
5	14614112	Front Insulation Board (2 Sec.)	1
	14614113	Front Insulation Board (3 Sec.)	1
	14614114	Front Insulation Board (4 Sec.)	1
	14614115	Front Insulation Board (5 Sec.)	1
	14614116	Front Insulation Board (6 Sec.)	1
6	14614020	Side Insulation Board (2 Sec.)	2
		Side Insulation Board (3 Sec.)	2
		Side Insulation Board (4 Sec.)	2
		Side Insulation Board (5 Sec.)	2
		Side Insulation Board (6 Sec.)	2
7	14614122	Rear Insulation Board (2 Sec.)	1
	14614123	Rear Insulation Board (3 Sec.)	1
	14614124	Rear Insulation Board (4 Sec.)	1
	14614125	Rear Insulation Board (5 Sec.)	1
	14614126	Rear Insulation Board (6 Sec.)	1
8	14695039	SCR, Block to Base 5/16"x1-1/4"	4
‡	14614032	Combustible Floor Plate (2 Sec.)	1
		Combustible Floor Plate (3 Sec.)	1
		Combustible Floor Plate (4 Sec.)	1
		Combustible Floor Plate (5 Sec.)	1
		Combustible Floor Plate (6 Sec.)	1
‡ Not illustrated			

# GAS CONVERSION KITS

NATURAL GAS TO PROPANE (LP)	
PART NO.	DESCRIPTION
<a href="#">550002722</a>	Kit Conversion Natural to LP (all sizes)
240009876	Instructions

PROPANE (LP) TO NATURAL GAS	
PART NO.	DESCRIPTION
<a href="#">43300660</a>	Kit Conversion LP to Natural (all sizes)
19956	Instructions

# LOW WATER CUT OFF KIT

LOW WATER CUT OFF KIT	
PART NO.	DESCRIPTION
<a href="#">550002998</a>	LWCO Kit
240010831	Instructions



2201 Dwyer Avenue, Utica, NY 13501  
Tel. 800 253 7900  
[www.ecrinternational.com](http://www.ecrinternational.com)

All specifications subject to change without notice.  
©2020 ECR International, Inc.