



95M-200

Aluminum Gas Fired Boilers For Forced Hot Water

REPAIR PARTS MANUAL

Ordering Instructions

Order Parts through your nearest supplier.

When ordering parts, obtain Model Number and Serial Number from data plate on your boiler.

Include following information when ordering.

Part Number _____

Part Description _____

Boiler Model Number _____

Boiler Serial Number _____



JACKET AND BASE ASSEMBLY

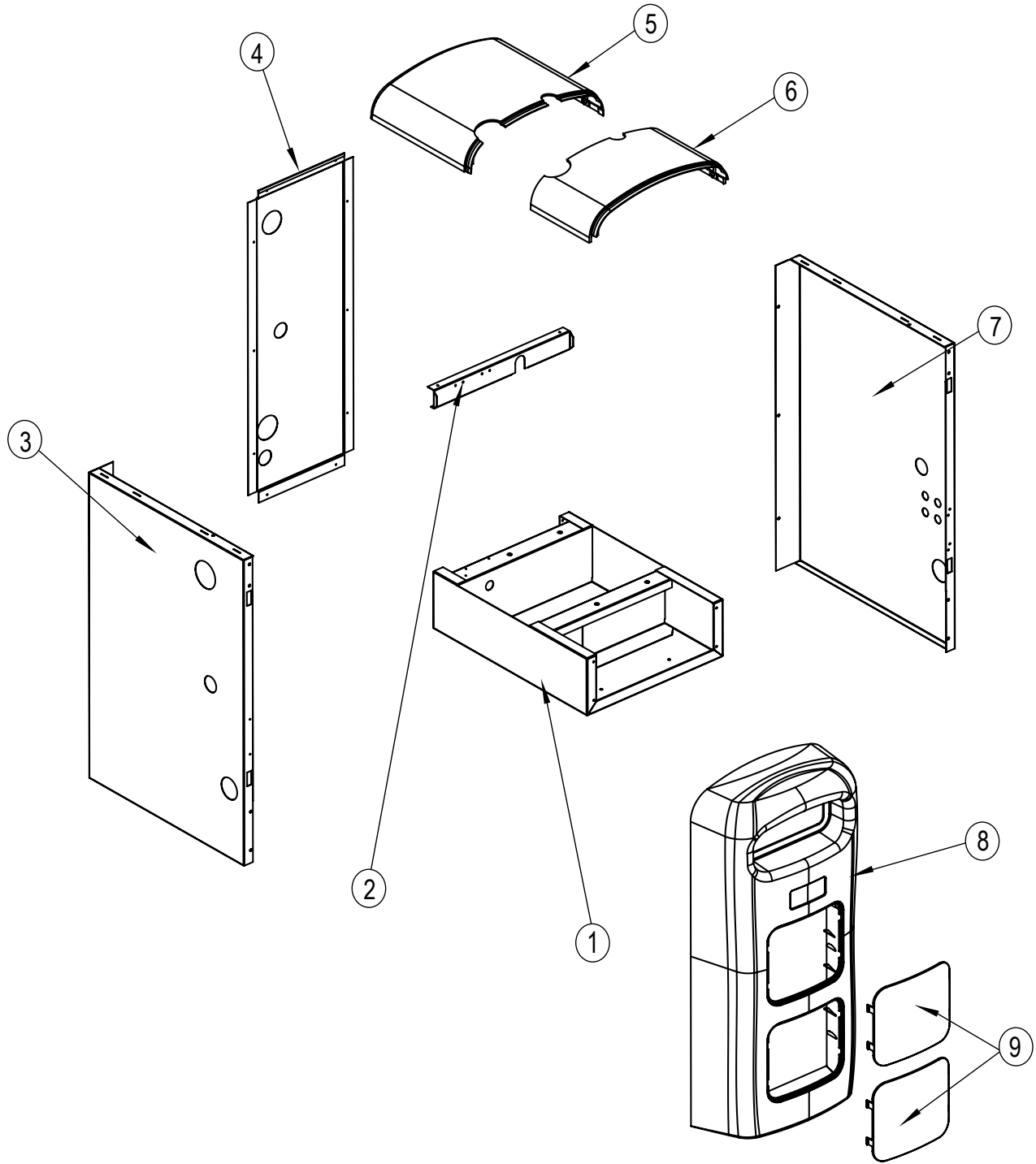

JACKET AND BASE ASSEMBLY

Item	DESCRIPTION	Part No.
1	Base Replacement Kit	550001473
2	Cross Bar Support	109005906
3	Left Side Panel Kit	550001478
4	Rear Panel Kit	2370023AC
5	Top Back Panel Kit	550001472
6	Top Front Panel Kit	550001471
7	Right Side Panel	2370021AC
8	Front Panel Kit (*)	550001470
*Not Shown	Jacket Replacement Kit (**)	550001321
*	Includes Item #9	
**	Includes Items #2 - #9	

ACCESSORY KITS

KIT NO.	DESCRIPTION
550001314	Honeywell AM (HAM) Accessory Module
550001315	Gas Conversion Kit (Natural To LP)
29571	3" Concentric Vent Kit, ULC S636
550001893	Left Side Combustion Air Intake Kit

BURNER/IGNITER ASSEMBLY

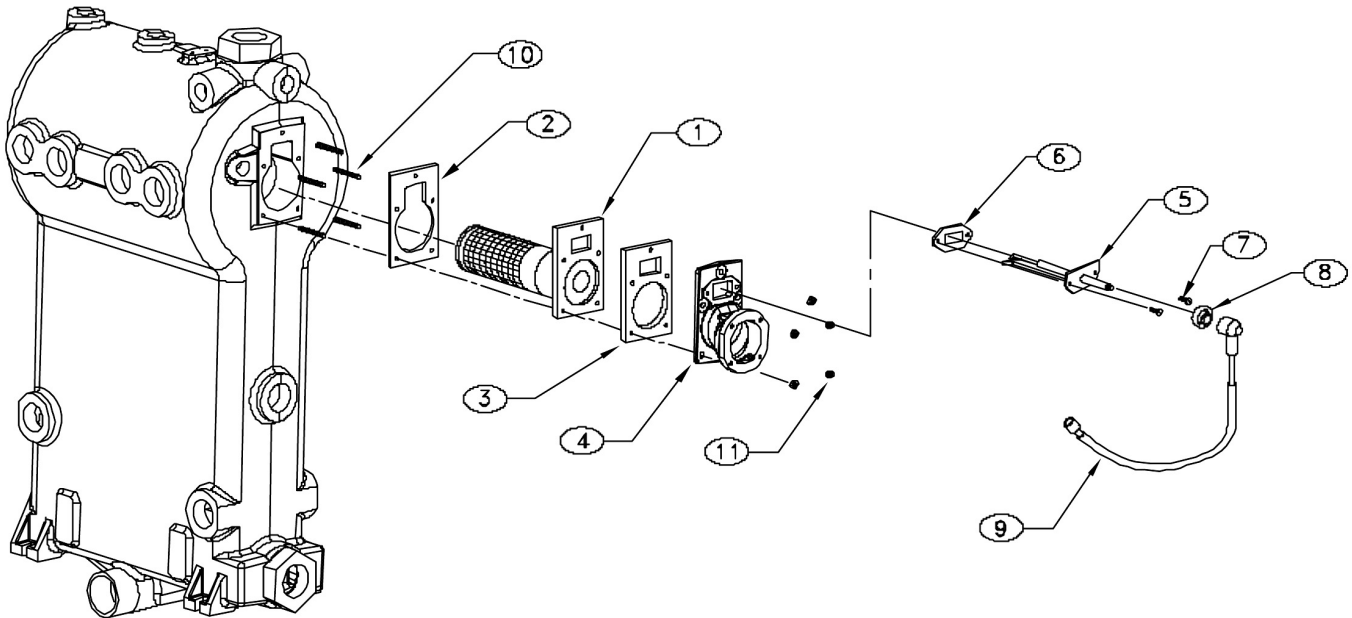

Item	Part No.	DESCRIPTION	Qty
4	12101022	Blower Adapter	1
Kit # 550001938 (95MC-200 modulating burner replacement kit) includes:			
1	240007052	Burner, Modulating, Worgas application	1
2	1250016	Grafoil Burner/Casting Gasket	1
3	1250015	Garfoil Burner/Flue Adapter Gasket	1
10	1450011	Stud Threaded 1/4"-20 x 1 1/2"	5
11	14695810	Nut Hex w/Serrated Washer 1/4"-20	5
Kit# 550001939 (95M-200 direct spark igniter replacement kit) includes:			
5	240007051	Igniter, Direct Spark, Worgas application	1
6	1250014	Garfoil Igniter/Mixer application	1
7	14695004	Screw 8-32 x 3/8" Slot HWH Self-Tap	2
Kit# 550001329 (95M-200 modulating igniter cable Replacement kit) includes:			
8	1240006	Grommet Igniter	1
9	1070001	Cable Igniter	1

EXHAUST TEE/CONDENSATE TRAP ASSEMBLY

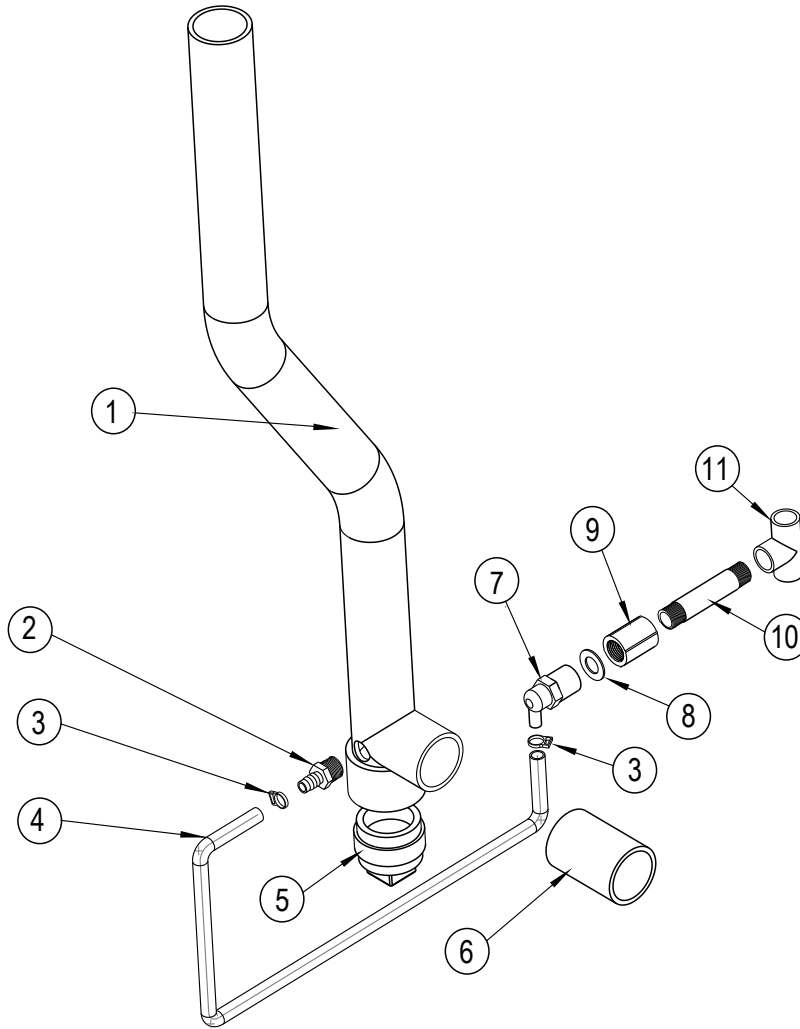

Item	Part No.	Description	Qty.
Kit# 550001465: 95M-200 Exhaust tee/condensate trap Replacement kit includes:			
1	1400012	Pipe Vent 2" CPVC Pre-formed, with hole	1
2	14631101	Hose Adapter, 1/2" NPT x 1/2" ID	1
3	14631141	Clamp Snap Grip 3/4"	2
4	14631035	Tubing Vinyl 1/2" ID x 1/8"	1.83 ft
5	240005852	Cleanout, 2" PVC	1
6	1400008	Pipe CPVC 2" x 3 3/8"	1
7	14631103	Tube Elbow 1/2" NPT x 1/2" ID	1
8	1600004	Washer, Flat 2" OD x 13/16" ID	1
9	14631306	Coupling 1/2" NPT PVC SCH 80	1
10	14631322	Nipple 1/2" x 4" PVC SCH 80	1
11	14631020	Tee PVC 1/2" SL x 1/2" NPT	1
*	240005853	Strap, Cable, Push Mount	1

* Not Shown

GAS VALVE PIPE ASSEMBLY

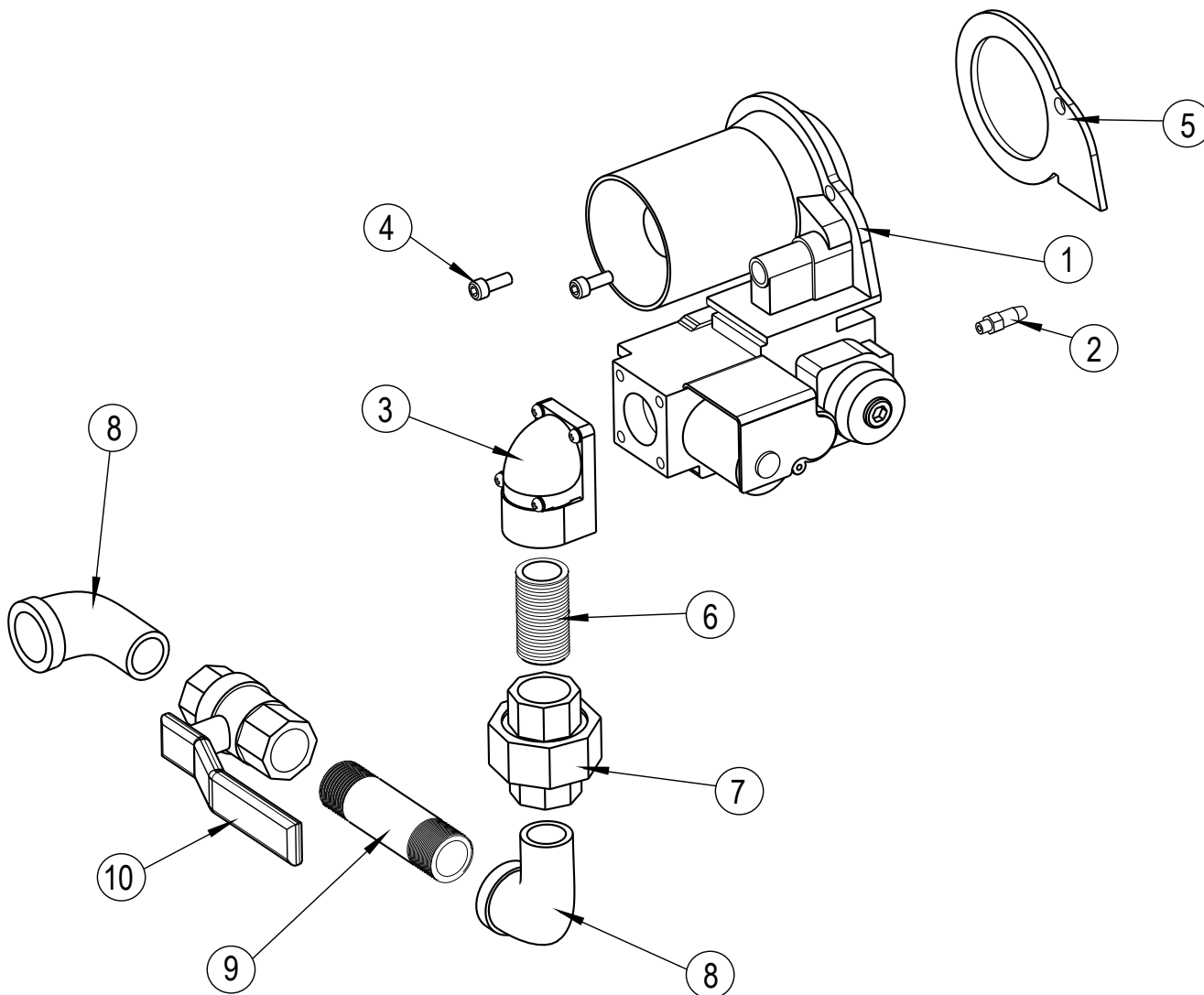

Item	Part No.	DESCRIPTION	Qty.
6	14607030	Nipple, Std, Black, Close 1/2"	1
7	14693043	Union, Std, Black 1/2"	1
8	14693801	Elbow, Street Mall, 1/2" x 90°	2
9	14607301	Nipple, Std., Black 1/2" NPT x 3"	1
10	1570038	Valve, Ball 1/2" (Blue)	1

Kit # 550001474 (95M-200 Gas Valve Replacement Kit) Includes:

1	240004794	Gas Valve, Modulating Venturi	1
2	1230005	Fitting, Pressure Feedback	1
3	240005020	Adapter, 90° NPT w/Gasket and Screws	1
4	1450012	Screw T25 Torx	2
5	1250021	Gasket, Cork, Venturi	1

BOILER BLOCK AND PIPING ASSEMBLY

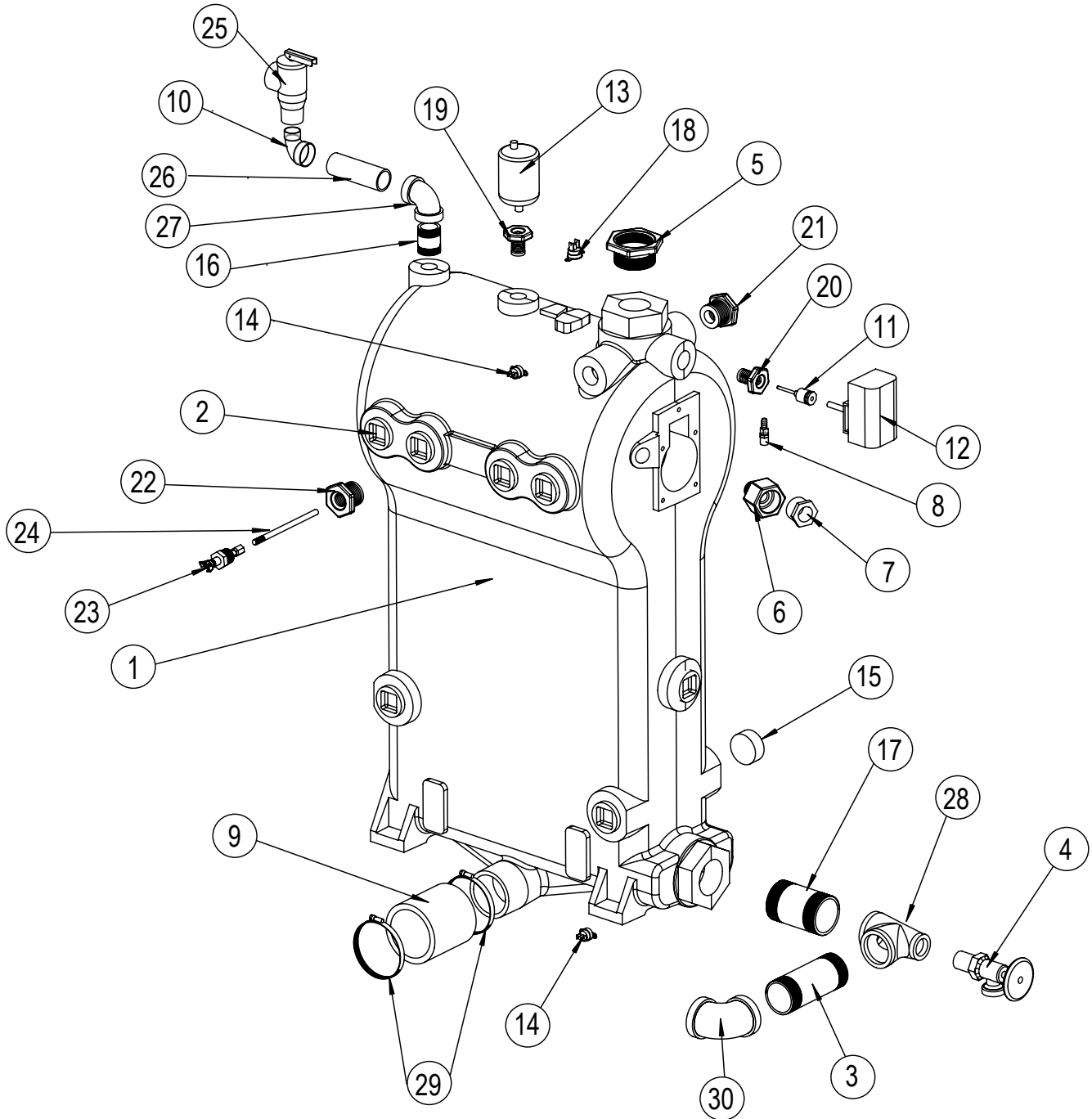

BOILER BLOCK AND PIPING ASSEMBLY

Item	Part No.	Description	Qty.
Kit 550001326 (95M-200 Block replacment kit) includes:			
1	240007283	Block, Machined/Tested	1
2	1395002	Plug, 1¼" Cast Iron Sq. Head Solid	16
3	1310002	Pipe, Nipple 1¼" x 4½" Black Iron	1
4	240009323	Valve, Boiler Drain ¾"	1
5	240006459	Bushing 1½" x 1¼" Forged Steel, 3000#	1
6	14631004	Adapter, Sight Glass	1
7	14619002	Observation Port ¾"	1
8	1230010	Fitting ⅝" NPT x 3/16", Barb Straight	1
9	14631301	Hose 3" Long 2⅜" ID x 2¾" OD	1
10	14693040	Elbow, Street Mall ⅜" x 90°	1
11	14662804	Well Control ½"	1
12	14631324	Aquastat	1
13	1580006	Vent Air Purge	1
14	1530003	Sensor 12k Ohms	2
Piping Assembly Parts			
15	240006957	Plug, 1" Cast Iron Sq. Head Solid	1
16	1230012	Fitting, Pipe, Black ¾" x 2½"	1
17	240006951	Nipple, Black 1½" x Close	1
18	1500005	Casting Temperature Switch	1
19	240006955	Bushing ¾" x ⅝" Black	1
20	240006952	Bushing ¾ x ½" Black	1
21	240006953	Bushing 1" x ¼" Black	1
22	240006954	Bushing 1" x ⅜" Black	1
23	1280012	LWCO Well	1
24	1280014	LWCO Probe Rod	1
25	14622011	Relief Valve ¾"	1
26	14607202	Nipple, Std. Black ¾" x 4½"	1
27	1190001	Elbow ¾" x 90°	1
28	240004863	Reducing Tee, Black 1½" x ¾" x 1¼"	1
29	14631302	Clamp, Stainless Steel #44	2
30	1190002	Elbow 1¼" x 90°	1
*	14695802	Screw, Soc Hd Cap 8-32 x 3/16"	6
*	240004804	Outdoor Sensor	1
*	240000112	Electric Anti-Short #1 - Insr. 5/16	1
*	1330001	Nut, Whizlock FLG PL 5/16"-18	4
*	1040004	Bolt, Carriage 5/16" X 1½"	4
*	14634012	Connector, Romex ½" K.O.	1
*	43300826	Wiring Harness, Circulator	1
*	CI-006.01	Circulator, Grunfos	1
*	CI-001.03	Circulator, Taco	1
* Not Shown			

AIR INTAKE ASSEMBLY

REAR COMBUSTION AIR INTAKE
Factory Supplied

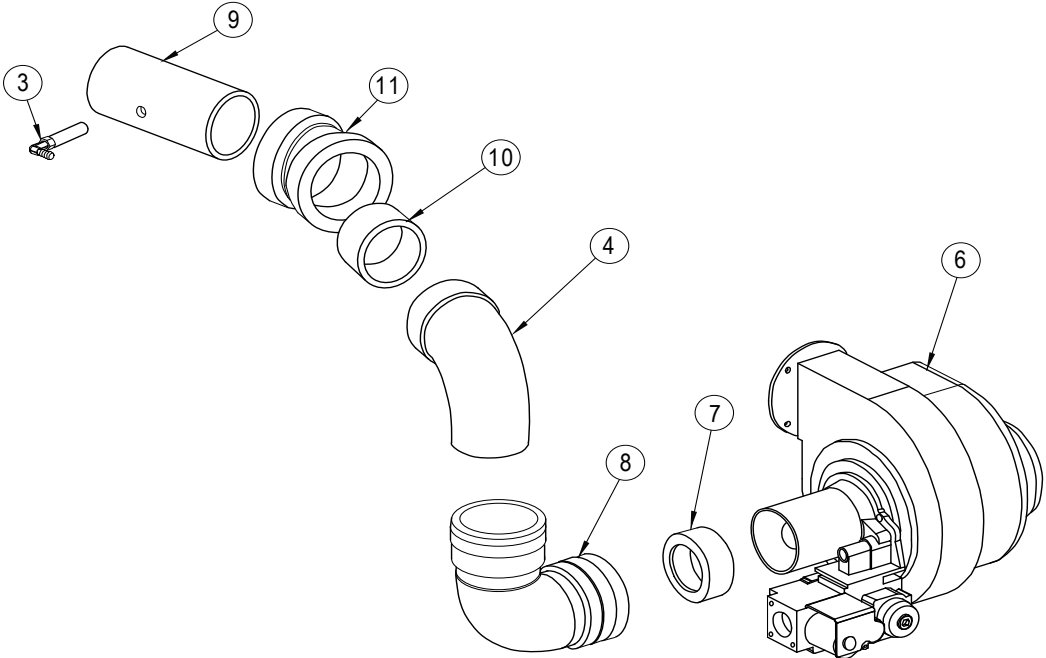

LEFT SIDE COMBUSTION AIR INTAKE
Field Convertible

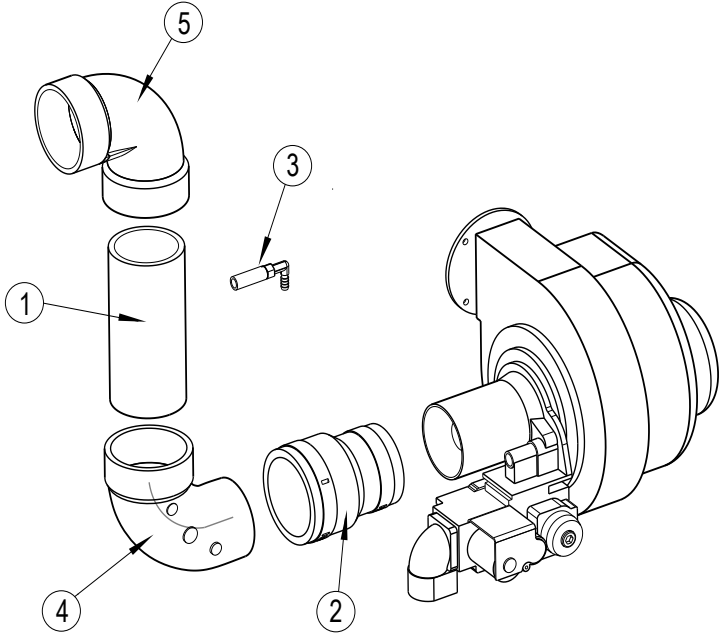

AIR INTAKE ASSEMBLY

Item	Part No.	DESCRIPTION	Qty.
Common Parts			
1	240006968	Vent Pipe 2" PVC x 3½" Long	1
2	14631311	Flex Coupling 2" x 1½"	1
3	800000348	95M Air Sensor Assembly	1
4	1190007	Elbow 2" Street 90° PVC	1
5	240004834	Elbow 2" PVC 90°	1
7	240006120	Bushing 1½" x 2" Flex	1
8	240006119	Elbow 2" Flex	1
9	240006820	Vent Pipe 2" CPVC SCH 40 x 29½" Long	19½"
10	1400007	Vent Pipe 2" PVC x 2" Long	1
11	240006147	Elbow 2" PVC 22.5°	1
Kit# 550001893 (95M-200 Left Side Air Intake Assy. Kit) Includes:			
1	240006968	Vent Pipe 2" PVC x 3½" Long	1
2	14631311	Flex Coupling 2" x 1½"	1
3	800000348	95M Air Sensor Assembly	1
4	1190007	Elbow 2" Street 90° PVC	1
5	240004834	Elbow 2" PVC 90°	1
Kit# 550001475 (95M-200 Blower Replacement Kit) Includes:			
6	1035002	Blower, Modulating	1
*	1250021	Gasket, Cork, Venturi	1
*	1250007	Gasket, Fan/Flue Adapter	1
*	1450009	Screw, 10-24 x ½" SSTL Hex Head Cap	4
*Not Shown			

AIR PRESSURE SWITCH ASSEMBLY

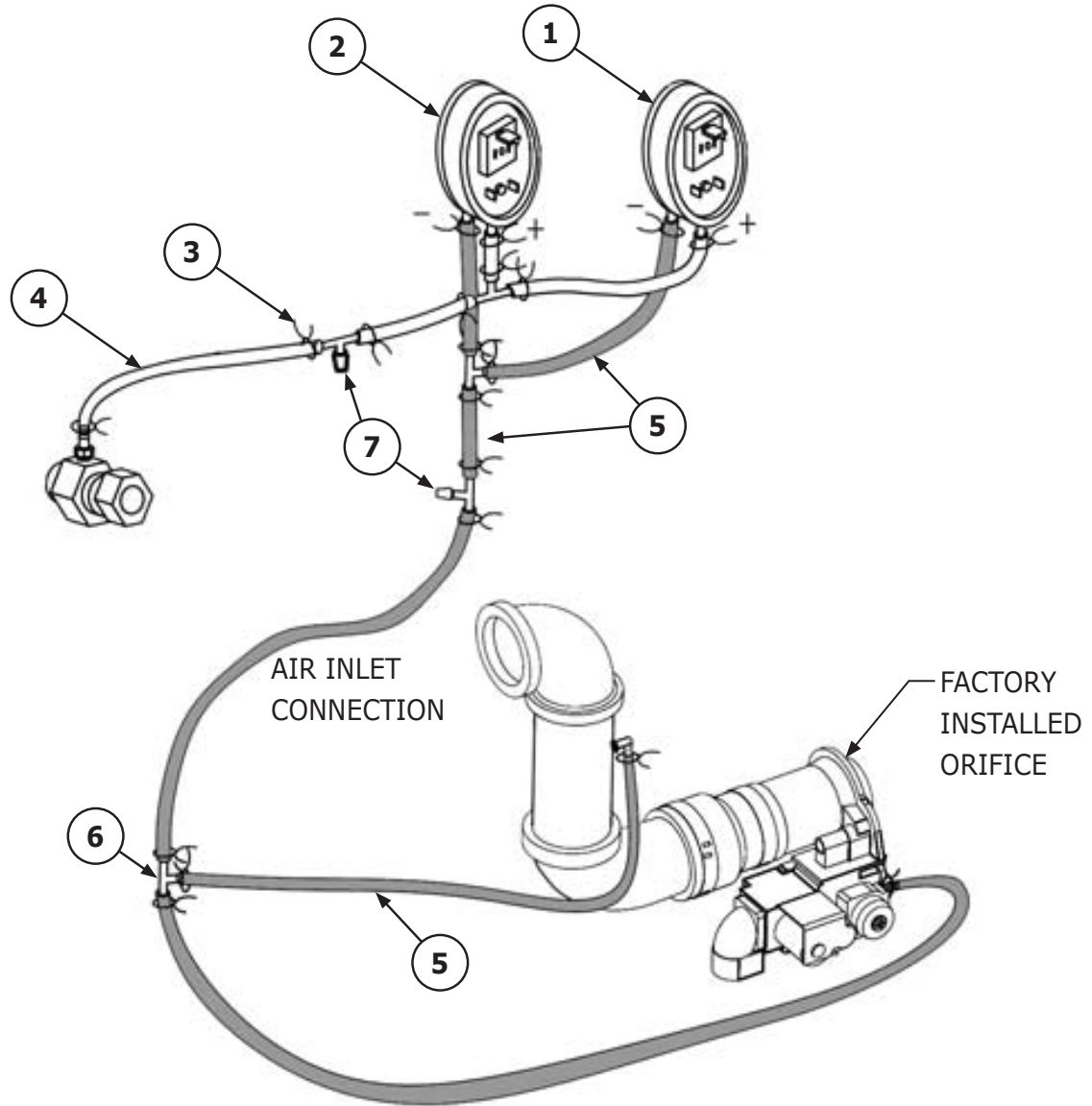

Item	Part No.	Description	Qty.
Kit# 550001466 (95m-200 Air Pressure Switch Replacement Kit) Includes :			
1	1500010	Pressure Switch, .04" N.O. Set Point	1
2	1500011	Pressure Switch, 3½" N.C. Set Point	1
3	1110001	Rotor Clamp	22
4	1552014	Silicone Tubing, 3/16" ID	Lengths Vary
5	1552004	Silicone Tubing, Orange 3/16" ID	
6	1510009	Tee, Plastic, Barbed Hose 3/16" ID	5
7	1230006	Cap, Vinyl, Black 3/16"	2
*	1640008	Pilot Orifice	1
*	PB-002.-02	Wire Jumper Pressure Switch	1
* Not Shown			

CONTROL PANEL ASSEMBLY

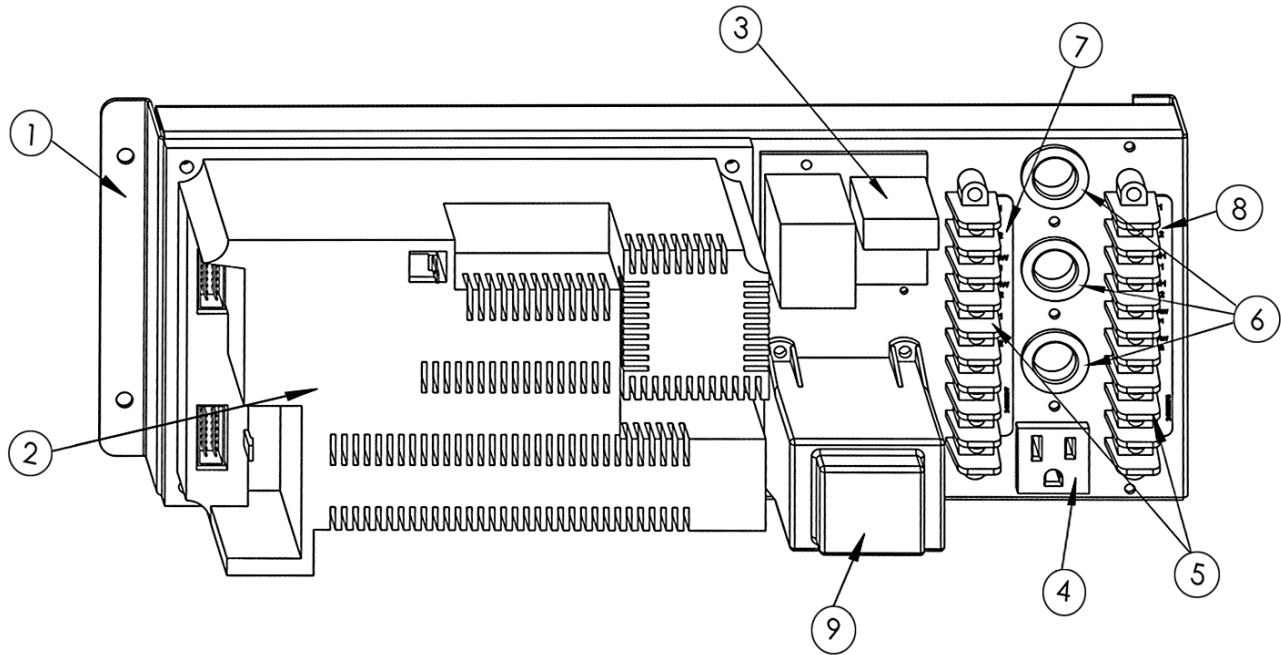

Item	Part No.	Description	Qty.
Common Parts			
1	109005907	Bracket, Control	1
3	1280013	LWCO, Panel Mounted	1
4	1407001	Receptacle	1
5	EF04001	Elec Beau 9 Term Strip	2
6	14693011	Bushing	3
7	-	Label, Control Panel, Low Voltage	1
8	-	Label, Control Panel, High Voltage	1
9	550003014	Transformer replacement kit	1
*	14631097	Rivet, Stainless Steel 1/4" x 1/8"	8
*	14631098	Hinge Slip, Lower	2
*	14631099	Hinge Slip, Upper	2
*	HW09001	Ground Screw 10-32 x 5/16"	3
*	14695074	Screw #10 x 1/2"	4
*	EF04101	Pop Rivet 1/8"	4
*	201000100	Screw #6 x 3/8"	4
Kit# 550001921 (95MC-200 MCBA Control Replacement Kit) Includes:			
2	1140012	Control, Modulation 95M Programmed, Rev C parameters	1
*	240006054	Fuse, 4A, Slow Blow (spares)	2
*	240006055	Fuse, 5A, Fast Blow (spares)	2
*	-	Label, Control, MCBA	1

DISPLAY PANEL ASSEMBLY

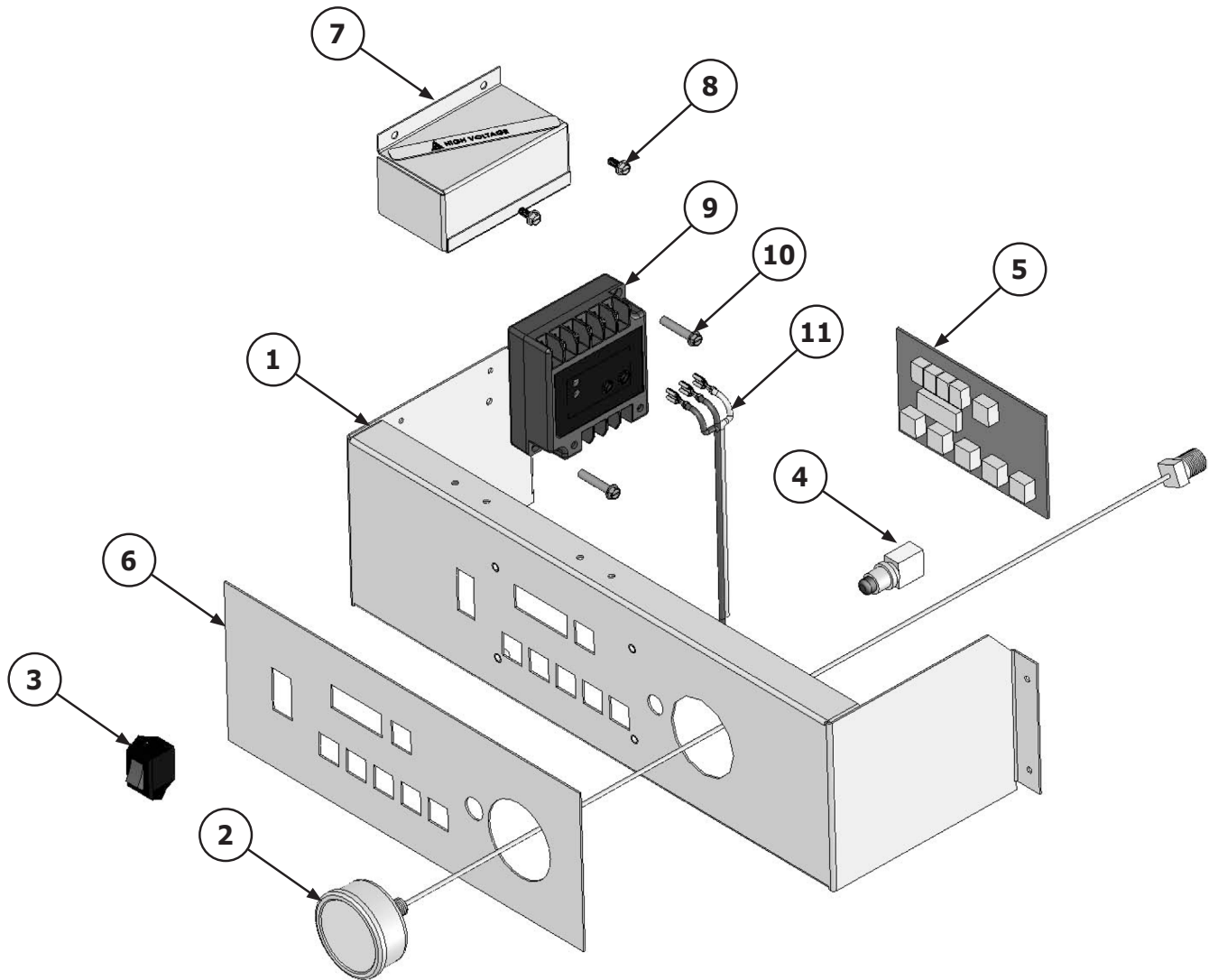

Item	Part No.	Description	Qty.
1	109005739	Display Panel	1
2	1260007	Pressure Gauge w/Capillaries	1
3	1500012	Main Power Rocker Switch	1
4	1500013	LWCO Push Button Reset Switch	1
5	240004792	Display Panel User Interface	1
6	---	Display Panel Label	1
7	3001565	Safety Cover with label for Line Monitor	1
8	201000001	#8 x 38" Screw	2
9	240007607	Line Monitor	1
10	240007659	#10 X 1" Screw	2
11	240007653	Wire Harness for Line Monitor	1
*	240004793	Ribbon Cable	1
*	1263021	High Voltage Wire Harness	1
*	240007205	Low Voltage Wire Harness	1

*Not Shown



DUNKIRK BOILERS
2201 Dwyer Avenue, Utica NY 13501
web site: www.ecrinternational.com