



Q95M-200 GAS-FIRED DIRECT VENT MODULATING HOT WATER BOILER

**Model
Q95M-200**

INSTALLATION, OPERATION & MAINTENANCE MANUAL



An ISO 9001-2008 Certified Company

Manufactured by:

ECR International, Inc.
2201 Dwyer Avenue, Utica NY 13501
web site: www.ecrinternational.com

P/N# 240006103D, Rev. E [02/2014]

1 - DIMENSIONS

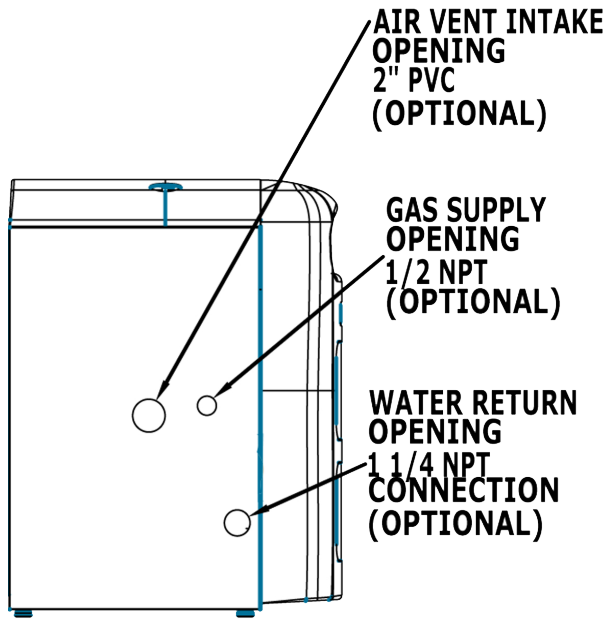

LEFT SIDE

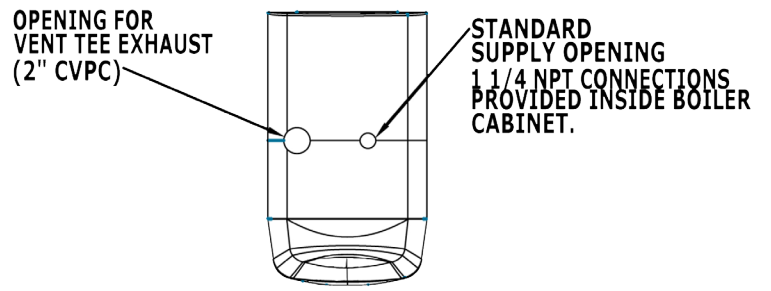

TOP

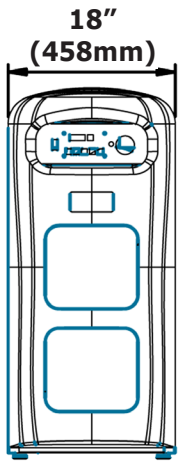

FRONT

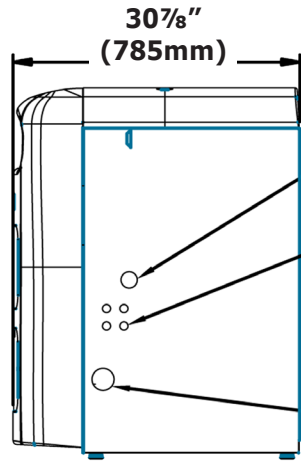

RIGHT SIDE

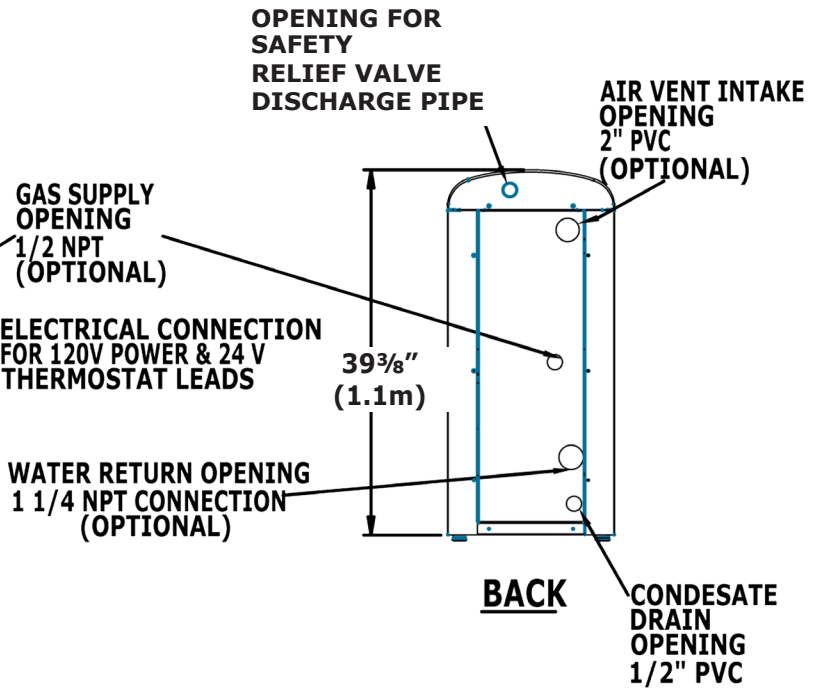

BACK

2 - INTRODUCTION

1 - Dimensions.....	2
2 - Introduction.....	3
3 - Important Safety Information.....	4
4 - Boiler Ratings & Capacities.....	5
5 - Before Installing The Boiler	6
6 - Locating The Boiler	7
7 - Near Boiler Piping	9
8 - Combustion Air And Vent Pipe	12
9 - Gas Supply Piping.....	17
10 - Electrical Wiring.....	19
11 - Controls And Accessories	21
12 - Boiler Startup.....	23
13 - Operating Instructions	24
14 - Maintenance And Cleaning	25
Appendix A - Boiler Piping And Wiring	27
Appendix B - Water Quality, Water Treatment and Freeze Protection	45

2.1 Introduction

- Boiler is certified in accordance with ANSI Z21.13 American National Standards Institute) and CSA (Canadian Standards Association) 4.9.
- This appliance is a gas-fired direct vent modulating cast aluminum hot water boiler.
- Cast aluminum monoblock heat exchanger allows better heat transfer and thermal storage than similarly sized cast iron boilers resulting in higher efficiency.
- The heating system water absorbs large amounts of heat from the cast aluminum heat exchanger, cooling flue gases and causing condensation.
- Sealed combustion, premix gas burner, and low flame temperature means reduced CO and NOx emissions, which contribute to cleaner and healthier environment.
- This appliance takes its combustion air directly from outdoors (sealed combustion) and does not compete with building occupants for fresh air.
- Sealed combustion (also known as "direct vent") is safest and best way to obtain plenty of clean combustion air.
- Forced draft fan draws in outside combustion air, takes cooler flue gases from boiler unit and provides positive removal of flue gases from the building through readily available PVC and CPVC pipes. Canada use ULC S636 Material.
- These low pressure gas-fired hot water boilers are design certified by CSA International for use with natural gas and propane gas.
- Boilers are constructed and hydrostatically tested for maximum working pressure of 50 psig (pounds per square inch gage) in accordance with A.S.M.E. (American Society of Mechanical Engineers) Boiler and Pressure Vessel Code Section IV Standards for heating boilers.

3 - IMPORTANT SAFETY INFORMATION

3.1 General

Boiler installation shall be completed by qualified agency. See glossary for additional information.

WARNING

Fire, explosion, asphyxiation and electrical shock hazard. Improper installation could result in death or serious injury. Read this manual and understand all requirements before beginning installation.

**Keep this manual near boiler
Retain for future reference**

Become familiar with symbols identifying potential hazards.



This is the safety alert symbol. Symbol alerts you to potential personal injury hazards. Obey all safety messages following this symbol to avoid possible injury or death.

DANGER

Indicates a hazardous situation which, if not avoided, WILL result in death or serious injury

WARNING

Indicates a hazardous situation which, if not avoided, could result in death or serious injury.

CAUTION

Indicates a hazardous situation which, if not avoided, could result in minor or moderate injury.

NOTICE

Used to address practices not related to personal injury.

3.2 Installation shall conform to requirements of authority having jurisdiction or in absence of such requirements:

- United States
 - National Fuel Gas Code, ANSI Z223.1/NFPA 54.
 - National Electrical Code, NFPA 70.
- Canada
 - Natural Gas and Propane Installation Code, CAN/CSA B149.1. and .2
 - Canadian Electrical Code, Part I, Safety Standard for Electrical Installations, CSA C22.1

3.3 Where required by authority having jurisdiction, installation shall conform to Standard for Controls and Safety Devices for Automatically Fired Boilers, ANSI/ASME CSD-1.

Additional manual reset low water cutoff and/or manual reset high limit may be required.

3.4 Requirements for Commonwealth of Massachusetts:

Boiler installation must conform to Commonwealth of Massachusetts code 248 CMR which includes but is not limited to:

- Installation by licensed plumber or gas fitter.

Installers - Follow local regulations with respect to installation of CO (Carbon Monoxide) Detectors. Follow maintenance recommendations "Maintenance And Cleaning" Section 14 page 25.

4 - BOILER RATINGS & CAPACITIES



TABLE 1: SEA LEVEL RATINGS - NATURAL AND PROPANE GASES

Input (MBH) ⁽¹⁾		Heating Capacity (MBH) ⁽¹⁾⁽²⁾	Net AHRI Rating (MBH) ⁽¹⁾	AFUE ⁽²⁾	Flue Diameter	Shipping Wt.
High Fire	200	182	158	92.5%	2" CPVC & 3" PVC	284 lbs.
Low Fire	80	73	63			

⁽¹⁾ 1 MBH = 1,000 BTUH (British Thermal Units Per Hour)

⁽²⁾ Heating Capacity and AFUE (Annual Fuel Utilization Efficiency) are based on DOE (Department of Energy) test procedures.

TABLE 2: 95M-200 HIGH ALTITUDE DERATE CHART

Input (MBH)	Altitude (In Feet)							
	3,000 ⁽²⁾	4,000 ⁽²⁾	5,000 ⁽³⁾	6,000	7,000	8,000	9,000	10,000
High Fire	196	192	177	174.5	172	169	168	167
Low Fire	78.4	76.8	115	113.5	112	110	109	108

⁽¹⁾ Boiler Input Rate is determined at minimum vent length. The rate will decrease as vent length increases.

⁽²⁾ Parameter 17 is set to 2,250 at elevations of 2,000 feet and below.

⁽³⁾ Parameter 17 must be raised to 3,200 at altitudes or elevations of 2,000 feet and above.

- Heating Capacity indicates amount of heat available after subtracting losses up the stack. Most of this heat is available to heat water. Small portion is heat loss from jacket and boiler surfaces, and it is assumed this heat stays in the structure.
- Net AHRI Rating represents portion of remaining heat that can be applied to heat radiation or terminal units (i.e., finned tube baseboard, cast iron radiators, radiant floor, etc.) Difference between Heating Capacity and Net AHRI Rating, called piping and pickup allowance, establishes reserve for heating volume of water in the system and offsetting heat losses from piping.
- Net AHRI Ratings shown are based on piping and pickup factor of 1.15 in accordance with AHRI Standard. Net AHRI Rating of selected boiler should be greater than or equal to calculated peak heating load (heat loss) for building or area(s) served by boiler and associated hot water heating systems. Consult manufacturer before selecting boiler for installations having unusual piping and pickup requirements.

5 - BEFORE INSTALLING THE BOILER

5.1 Before Boiler Installation

1. Boiler is equipped for residential installations. If used for commercial applications, additional code requirements must be adhered to for installation. This may require additional controls including but not limited to a low water cut off, a manual reset high temperature limit, and wiring and/or piping modifications.
2. Never vent products of combustion from this boiler to enclosed space. Always vent to outdoors. Never vent to another room or to inside building.
3. Keep boiler area clean of debris and free of combustible and flammable materials.
4. Proper through wall or through roof combustion venting shall be in accordance with materials and methods described in this manual. Installation must comply with local codes.

5.2 Boiler Sizing

- Verify you have selected boiler with proper capacity before continuing installation. AHRI Rating of selected boiler should be greater than or equal to calculated peak heating load (heat loss) for the building or area(s) served by boiler and associated hot water heating systems. See *Sea Level Ratings - Natural and Propane Gases* Section 4.
- Heat loss calculations should be based on approved industry methods.

5.3 Considerations for Boiler Location

Before selecting boiler location consider following.

- Supplied with correct type of gas (natural gas or propane).
- Connected to suitable combustion air intake piping system to supply correct amounts of fresh (outdoor) air for combustion (15' minimum equivalent length/100' maximum equivalent length).
- Connected to suitable venting system. (15' minimum equivalent length/100' maximum equivalent length).
- Connected to suitable hot water heating system.
- Supplied with suitable electrical supply for all boiler motors and controls.
- Connected to properly located thermostat or operating control (not included with boiler).

WARNING

Fire hazard. Do not install on carpeting. Failure to follow these instructions could result in death or serious injury.

- Placed on level surface (must NOT be installed on carpeting).
- Pitch condensate drain line down to floor drain or external condensate pump with reservoir at ¼" per foot (wood frame or blocks may be used to raise boiler).

6 - LOCATING THE BOILER

6.1 Locating the Boiler

1. Place crated boiler as close to selected location as possible and un-crate boiler. Boiler may be moved into position with appliance dolly or 2 wheel hand truck. Insert dolly or hand truck under **right hand side** of boiler. It is possible to slide boiler for short distance on smooth floor or surface.
2. Select level location central to piping systems served and as close to vent and air intake terminals as possible.
3. Accessibility clearances, if more stringent (i.e. larger clearances) than required fire protection clearances, must be used for boiler installation. Accessibility clearances may be achieved with use of removable walls or partitions.

⚠ WARNING

Fire hazard. Do not install on carpeting. Failure to follow these instructions could result in death or serious injury.

4. Boiler is approved for installation in closets and on combustible floors. Boiler shall NOT be installed on carpeting.
5. Clearances shown in Table 3 indicate required clearances per CSA listing. Minimum 1" (26mm) clearance must be maintained between combustible construction and each of the right, top and back surfaces of the boiler. Allow at least 24" (610mm) at front and left side and 8" (204mm) at top for servicing. No combustible clearances are required to venting or combustion air intake piping.
6. Install equipment in location which facilitates operation of venting and combustion air intake piping systems as described in this manual.
7. Advise owner to keep venting and combustion air intake passages free of obstructions. Both venting and combustion air intake piping systems connected to outdoors must permit flow through piping systems without restrictions for boiler to operate.
8. Install boiler so automatic gas ignition system components are protected from water (dripping, spraying, rain, etc.) during operation and service (circulator replacement, control replacement, etc.).
9. Keep boiler area clean of debris and free of flammable and combustible materials, vapors and liquids.
10. Locate boiler where ambient room temperatures (minimum possible temperatures where boiler is installed assuming boiler is not in operation and therefore contributes no heat to space) are always at or above 32°F (0°C) to prevent freezing of liquid condensate.

TABLE 3: BOILER CLEARANCES

Dimension	Combustible Construction	Accessibility/Cleaning	Service
Top	1" (26mm)	8" (204mm)	8" (204mm)
Left Side	1" (26mm)	24" (610mm)	24" (610mm)
Right Side	1" (26mm)	-	-
Base	Combustible	-	-
Front	0	24" (610mm)	24" (610mm)
Back	6" (153mm)	-	-
Intake/Vent Piping	0	-	-
Near Boiler Hot Water Piping	1" (26mm)	-	-

Figure 1 - Minimum Clearances To Combustible Construction

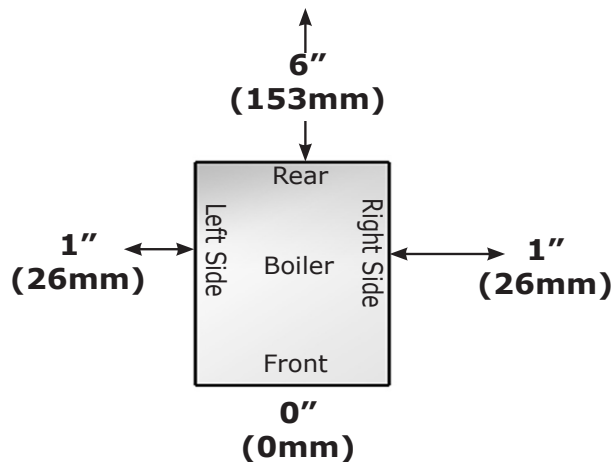

6 - LOCATING THE BOILER

6.2 Combustion Air and Vent Pipe Requirements

- This boiler requires dedicated direct vent system.
- In direct vent system all air for combustion is taken directly from outside atmosphere, and all flue products are discharged to outside atmosphere.
- Combustion air and vent pipe connections must terminate together in same atmospheric pressure zone, either through roof or sidewall (roof termination preferred). See Figures 5 and 6 for required clearances. For proper set up of concentric vent termination see Figure 7 and Figure 8.

WARNING

Solvent cements are combustible. Keep away from heat, sparks, and open flame. Use only in well ventilated areas. Avoid breathing in vapor or allowing contact with skin or eyes. Failure these instructions could result in fire, personal injury, or death.

- Locate combustion air inlet as far away as possible from swimming pool and swimming pool pump house.
- All combustion air and vent pipes must be airtight and watertight. Combustion air and vent piping must also terminate as shown in "Combustion Air and Vent Pipe" section.
- Vent connections serving appliances vented by natural draft shall not be connected into any portion of mechanical draft systems operating under positive pressure.
- Covering non-metallic vent pipe and fittings with thermal insulation shall be prohibited.

6.3 Condensate Drain Requirements

- Condensate trap provided with boiler, an additional trap is not required and should not be used.
- Pitch condensate drain line down to floor drain at minimum of ¼" per foot. External condensate pump (not furnished) may be used if floor drain is not available.
- Condensate pump must be designed for flue gas condensate application.
- Wood frame or blocks may be used to raise boiler to maintain drain pitch or to be above external condensate pump reservoir.
- If boiler is not level, condensate drain lines will not function properly. Adjustable feet are located on boiler to make up for minor surface irregularities or tilt.
- 115 volt AC receptacle provided on control panel to provide power for external condensate pump if used.

6.4 Removal of Existing Boiler From Common Vent System

When an existing boiler is removed from a common venting system, the common venting system is likely to be too large for proper venting of the appliances remaining connected to it. At the time of removal of an existing boiler, the following steps shall be followed with each appliance remaining connected to the common venting system placed in operation, while the other appliances remaining connected to the common venting system are not in operation.

1. Seal any unused openings in the common venting system.
2. Visually inspect the venting system for proper size and horizontal pitch and determine there is no blockage, or restrictions, leakage, corrosion and other deficiencies which could cause an unsafe condition.
3. In-so-far as is practical, close all building doors and windows and all doors between the space in which the appliances remaining connected to the common venting system are located and other spaces of the building. Turn on clothes dryer and any appliance not connected to the common venting system. Turn on any exhaust fans, such as range hoods and bathroom exhaust, so they will operate at maximum speed. Do not operate a summer exhaust fan. Close fire dampers.
4. Place in operation the appliance being inspected. Follow the lighting instructions. Adjust thermostat so appliances will operate continuously.
5. Test for spillage at the draft hood relief opening after 5 minutes of main burner operation. Use the flame of a match or candle, or the smoke from a cigarette, cigar or pipe.
6. After it has been determined that each appliance remaining connected to the common venting system properly vents when tested as outlined above, return doors, windows, exhaust fans, fire place dampers, and any other gas-burning appliance to their previous condition of use.
7. Any improper operation of the common venting system should be corrected so the installation conforms with the National Fuel Code, NFPA-54/ANSI -Z223.1 and/or the Natural Gas and Propane Installation Code, CAN/CSA B149.1. When re-sizing any portion of common venting system, common venting system should be re-sized to approach minimum size as determined using appropriate tables in Chapter 13 of the National Fuel Gas Code, NFPA-54/ANSI- Z223.1 and/or the Natural Gas and Propane Installation Code, CAN/CSA B149.1.

7 - NEAR BOILER PIPING

7.1 Clean System First

Before connecting boiler to heating system, clean and flush system thoroughly. Verify system is free of sediment, flux and any residual boiler water additives.

Systems having antifreeze not recommended must be completely flushed to insure no old antifreeze remains. In older systems obviously discolored, murky or dirty water; or pH reading outside acceptable range (between 7.0 and 8.0) are indications system should be cleaned or treated. Thoroughly flush system with clean water to remove any sediment or contaminants. Sludge and iron oxide deposits can cause rapid breakdown of inhibitors.

Flushing with clean water. If chemical cleaners are used, use only those recommended for use with aluminum boilers. Follow chemical cleaner manufacturer's instructions completely.

DO NOT mix different manufacturer's products.

- When boiler installation is for new heating system, install all of radiation units (panels, radiators, baseboard, or tubing) and supply and return mains.
- After all heating system piping and components have been installed, make final connection of system piping to boiler.
- Hot water boiler installed above radiation level, or as required by the Authority having jurisdiction, must be equipped with low water cut off device. This boiler is factory equipped with manual reset probe type low water cutoff.
- Periodic inspection is necessary per low water cut off manufacturers specific instructions.

7.2 Supply & Return Lines

See Appendix A for piping examples.

- Packaged boiler set to receive 1¼" NPT return piping from rear of unit with option for left or right return connections.
- Use two furnished dielectric unions at boiler supply and return connections between copper system piping and boiler. Do not install copper supply and return piping directly into aluminum boiler casting due to galvanic corrosion between dissimilar metals.
- 1¼" NPT supply piping exits boiler jacket at top of unit.
- Some boilers supplied with circulator pump and isolation valves are furnished in a carton inside boiler cabinet and can be installed at installer preferred location.

7 - NEAR BOILER PIPING

7.3 Safety Relief Valve / Temperature Pressure Gauge

⚠ WARNING

Burn and scald hazard. Safety relief valve could discharge steam or hot water during operation. Install discharge piping per these instructions.

Installation of (supplied) safety relief valve shall conform to ANSI/ASME Boiler and Pressure Vessel Code, Section IV.

- Install furnished safety relief valve using 3/4" pipe fittings provided with boiler. See Figure 2.
- Install safety relief valve with spindle in vertical position.
- Do not install shutoff valve between boiler and safety relief valve.
- Install discharge piping from safety relief valve. See Figure 2.
- Use 3/4" or larger pipe.
- Use pipe suitable for temperatures of 375°F (191°C) or greater.
- Individual boiler discharge piping shall be independent of other discharge piping.
- Size and arrange discharge piping to avoid reducing safety relief valve relieving capacity below minimum relief valve capacity stated on rating plate.
- Run pipe as short and straight as possible to location protecting user from scalding.
- Install union, if used, close to safety relief valve outlet.
- Install elbow(s), if used, close to safety relief valve outlet and downstream of union (if used).
- Terminate pipe with plain end (not threaded).

7.4 Expansion Tank & Make-up Water

- Determine required system fill pressure, system design temperature, and system water content.
- Boiler contains 2.6 gallons (US). Size expansion tank accordingly.
- Consult expansion tank manufacturer for proper sizing information. Connect properly sized expansion tank (not furnished) as shown in Figure 3 for diaphragm type expansion tank.
- Adjust tank air pressure on diaphragm type expansion tanks to match system fill pressure.
- Install air vent (furnished) as shown for diaphragm type expansion tank system only.
- Install make-up water connections as show.
- If pressure reducing valve is used, adjust to match system fill pressure.
- Verify clean water supply is available when connecting cold make-up water supply to boiler.
- Use sand strainer at pump if water supply is from well or pump.

Figure 2 - Safety Relief Valve Discharge Piping

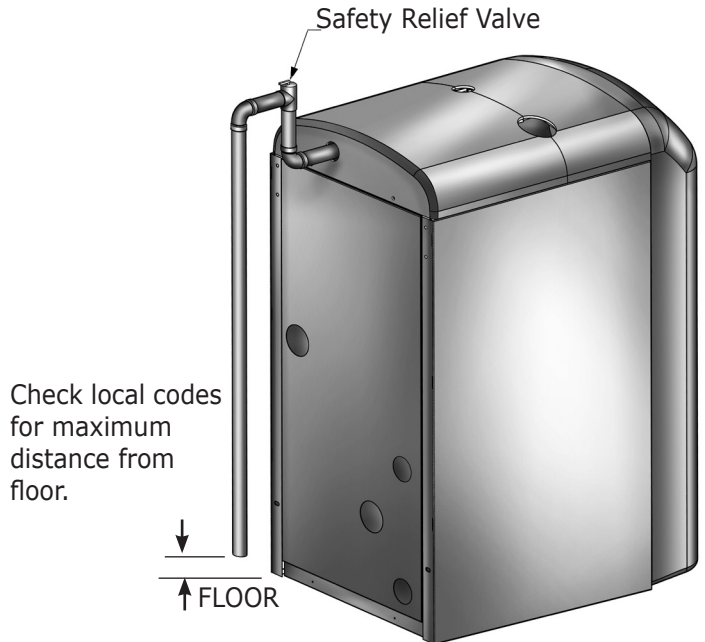
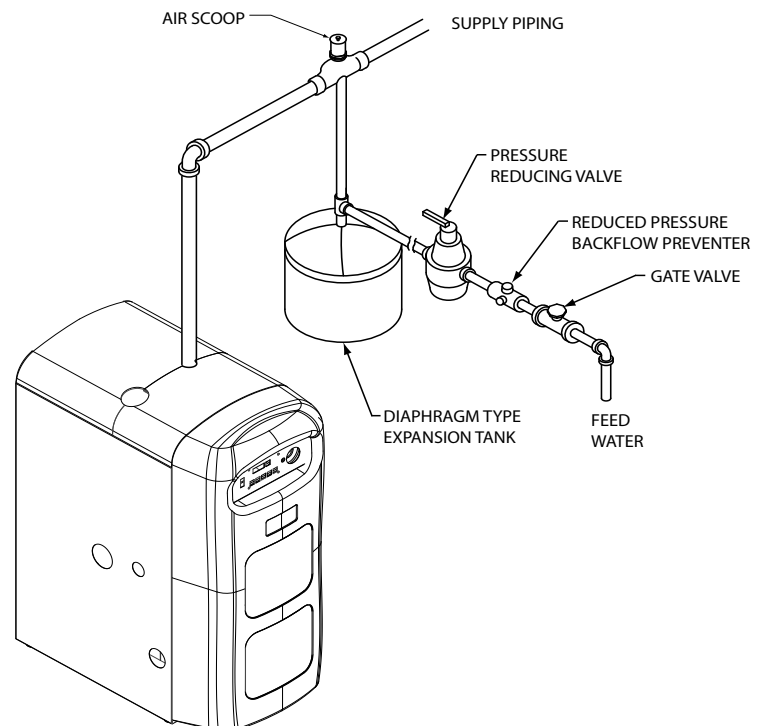

Figure 3 - Diaphragm Type Expansion Tank Piping



7 - NEAR BOILER PIPING

7.5 Condensate Drain Piping

Boiler is factory equipped with a condensate trap. Additional trap is not required and should NOT be used.

- Use supplied 1/2" PVC tee, transition to 1/2" pipe and fittings for PVC condensate drain line.
- The 1/2" diameter schedule 40 PVC or CPVC condensate drain and pipe fittings must conform to ANSI standards and ASTM D 1785 or D2846.
- Schedule 40 PVC or CPVC cement and primer must conform to ASTM D2564 or F493. In Canada, use CSA or ULC certified schedule 40 PVC drain pipe and cement.
- Condensate pump with reservoir (not furnished) to remove condensate to drain line (sanitary line) above boiler if floor drain is not available or is inaccessible.

7.6 Filling Condensate Trap with Water

On initial start up manually fill condensate trap with water.

Following are steps required to initially fill condensate trap for start up. Steps are only required at initial start up or if maintenance requires draining of condensate trap.

1. Remove vent drain line from CPVC vent pipe. Pour about 1 cup of cold tap water into vent drain line.
2. Excess water should go through overflow and out through condensate drain line. Verify proper operation of drain line (or external condensate pump if used).
3. Reinstall vent drain line.

7.7 Chilled Water Piping

Install Boiler, when used in connection with refrigeration system, so chiller medium is piped in parallel with boiler with appropriate valves to prevent chilled medium from entering boiler.

Piping system of hot water boiler connected to heating coils located in air handling units where they may be exposed to refrigerated air circulation must be equipped with flow control valves or other automatic means to prevent gravity circulation of boiler water during cooling cycle.

8 - COMBUSTION AIR AND VENT PIPE

8.1 Connections And Termination

Boilers for connection to gas vents or chimneys, vent installations shall be in accordance with "Venting of Equipment" of the National Fuel Gas Code, ANSI Z223.1/ NFPA 54, or "Venting Systems and Air Supply for Appliances", of the Natural Gas and Propane Installation Code, CAN/CSA B149.1, or applicable provisions of local building codes.

Provisions for combustion and ventilation air must be in accordance with section, Air For Combustion and Ventilation, of the National Fuel Gas Code, ANSI Z223.1/ NFPA54, National Gas and Propane Installation Code, CAN/ CGA-B 149.1, in absence of such requirements to the Authority having jurisdiction.

Boilers require dedicated direct vent system. All air for combustion is taken directly from outdoors through combustion air intake pipe. All flue products are discharged to outdoors through vent pipe.

1. See Figures 5 and 6 for two pipe combustion air and vent pipe roof and sidewall termination. Roof termination is preferred. Combustion air and vent pipes must terminate together in same atmospheric pressure zone as shown.
2. Use of concentric vent termination see Figures 7-9 for proper setup.
3. For Canadian installations all plastic venting material must be listed to ULC S636.
4. Construction through which vent and air intake pipes may be installed is maximum 24 inches, minimum ¼" thickness.
5. See Table 5 for combustion air and vent pipe fittings approved material and standards.
6. **Canada** construct all combustion air and vent pipes for this unit of ULC S636 listed schedule-40 CPVC, schedule-40 PVC, PVC-DWV or ABS-DWV pipe and pipe cement. SDR pipe is not approved in Canada.
 - First 3 feet (900mm) of venting must be readily available for visual inspection.
 - Specified primers and glues of certified vent system must be from single manufacturer, and not intermixed with other manufacturer's vent system parts.
 - Components of the certified system must not be interchanged with other vent systems, or unlisted pipe and/or fittings.

NOTICE

Transition from 2" pipe to 3" pipe must be made in vertical run.

7. Boiler combustion air and vent pipe connections are 2" but must increase to 3". Due to potential for flue gas temperatures above 155°F, first 30" of supplied vent pipe is CPVC while remaining vent pipe can be PVC. Any replacement of first 30" of vent pipe must be made with CPVC.
8. Covering non-metallic vent pipe and fittings with thermal insulation shall be prohibited.

TABLE 4					Maximum Allowable Temperatures Of Typical Non-Metallic Vent Material				
Material	HDT		RTI		Standard				
	°F	°C	°F	°C					
PVC	158	70	-	-	ASTM F 891 * ASTM D2665 ** ASTM D1785 ** ASTM D2241 **				
CPVC	210	100	-	-	ASTM D2846 ** ASTM F441 ** ASTM F442 **				
ABS	180	82	-	-	ASTM D2661 *** ASTM F628 ***				

* Allowable temperatures based on Classifications covered in ASTM D4396 [Deflection Temperatures under Load (264psi) (1819 KPa)].

** Allowable temperatures based on Classifications covered in ASTM D1784 [Deflection Temperatures under Load (264psi) (1819 KPa)].

*** Allowable temperatures based on Classifications covered in ASTM D3965 [Deflection Temperatures under Load (264psi) (1819 KPa)].

Length of pipe is counted from end of supplied 2" CPVC pipe exiting boiler. Termination is not counted in "Total Equipment Length."

Table 5 - Combustion air and vent pipe fittings must conform with the following:

Item	Material	Standards
Vent Pipe and Fittings	PVC schedule 40	ANSI/ASTM D1785
	PVC - DWV	ANSI/ASTM D2665
	CPVC schedule 40	ANSI/ASTM D1784/ F441
	SDR-21 & SDR-26 PVC	ANSI/ASTM D2241
	ABS-DWV	ANSI/ASTM D2661
	Schedule 40ABS	ANSI/ASTM F628
	PP (Polypropylene) Pipe and Components	UL 1738 ULC S636-08
Pipe Cement/ Primer	PVC	ANSI/ASTM D2564
	CPVC	ANSI/ASTM F493
	Schedule 40 ABS	ANSI/ASTM D2235

- IPEX is approved vent manufacturer in Canada listed to ULC-S636.
- IPEX System 636 Cements and Primers are approved in Canada listed to ULC-S636.

Use of cellular core PVC (ASTM F891), cellular core CPVC, or Radel®, (Polyphenolsulfone) in venting systems shall be prohibited.

⚠ WARNING

Use of cellular core PVC for venting flue gas could result in death, or serious injury.

8 - COMBUSTION AIR AND VENT PIPE

⚠ WARNING

Covering non-metallic vent pipe and fittings with thermal insulation shall be prohibited.

Allowable Vent and Air Intake Lengths

3" Pipe Min. Length	3" Pipe Max. Length
15 ft. equivalent length	100 ft. equivalent length

Length of pipe is counted from end of supplied 2" CPVC pipe exiting boiler. Termination is not counted in "Total Equivalent Length."

Reduce maximum vent/air intake length by 5 feet per each 90° elbow.

Figure 4 - Combustion Air & Vent Piping

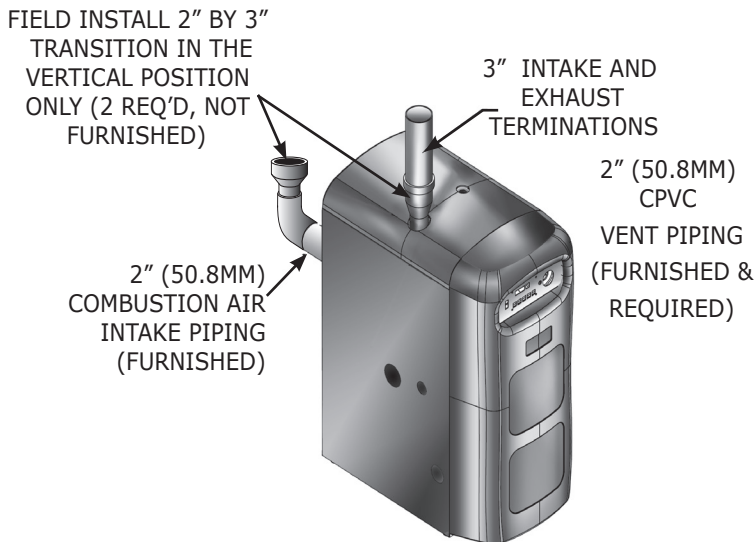

9. Combustion air must be clean outdoor air. Do not take combustion air from inside structure because that air is frequently contaminated by halogens, which includes fluorides, chlorides, phosphates, bromides and iodides. These elements are found in aerosols, detergents, bleaches, cleaning solvents, salts, air fresheners, paints, adhesives, and other household products.
10. Locate combustion air inlet as far away as possible from swimming pool and swimming pool pump house.
11. All combustion air and vent pipes must be airtight and watertight.
12. Pitch exhaust air piping back to boiler at minimum 1/4" per foot from vent terminals so all moisture in vent piping drains to boiler. Pitch pipes with no sags or low spots where moisture can accumulate and block flow of flue gas.
13. Vent connections serving appliances vented by natural draft shall not be connected into any portion of mechanical draft systems operating under positive pressure.

8.2 Vent/Air Intake Termination Location

Consider following when determining appropriate location for termination of combustion air and vent piping.

- A. Position termination where vent vapors will not damage plants/shrubs, air conditioning equipment, or siding on the house.
- B. Position termination so it will not be effected by wind eddy, air born leaves, snow, or recirculated flue gases.
- C. Position termination where it will not be subjected to potential damage by foreign objects, such as stones, balls, etc.
- D. Position termination where vent vapors are not objectionable.
- E. Put vent on wall away from prevailing winter wind. Locate or guard vent to prevent accidental contact with people or pets.
- F. Terminate vent above normal snow-line. Avoid locations where snow may drift and block vent. Ice or snow may cause boiler to shut down if vent becomes obstructed.
- G. Under certain conditions, flue gas will condense, forming moisture, and may be corrosive. In such cases, take steps to prevent building materials at vent from being damaged by exhaust of flue gas.
- H. United States - Terminate vent system at least 4 feet (1.22 m) horizontally from, and in no case above or below, unless a 4 feet (1.22 m) horizontal distance is maintained, from electric meters, gas meters, regulators and relief equipment.
- I. Canada - Terminate vent system at least 6 feet (1.83m) horizontally from, and in no case above or below, unless 6 feet (1.83m) horizontal distance is maintained, from electric meters, gas meters, regulators and relief equipment.
- J. Terminate venting system at least 3 feet (0.3m) above any forced air inlet (except boiler's combustion air inlet) within 10 feet (3m).
- K. Terminate venting system at least 12 inches (300mm) from any air opening into any building.
- L. Locate bottom of vent at least 12 inches (300mm) above grade.
- M. Terminate vent not less than 7 feet (2.1m) above adjacent public walkway.
- N. Vent terminal shall not be installed closer than 3 feet (0.9m) from inside corner of L shaped structure.
- O. Termination of vent should be kept at least 3 feet (0.9m) away from vegetation.
- P. If multiple terminations are used, minimum of 12 inches (300 mm) between exhaust of one termination and air intake of next termination. See pages 14 & 15.
- Q. All field installed vent pipe must be 3".

8 - COMBUSTION AIR AND VENT PIPE

Figure 5 - Side Wall Vent / Intake terminations - Less Than 12" Clearance Above Grade

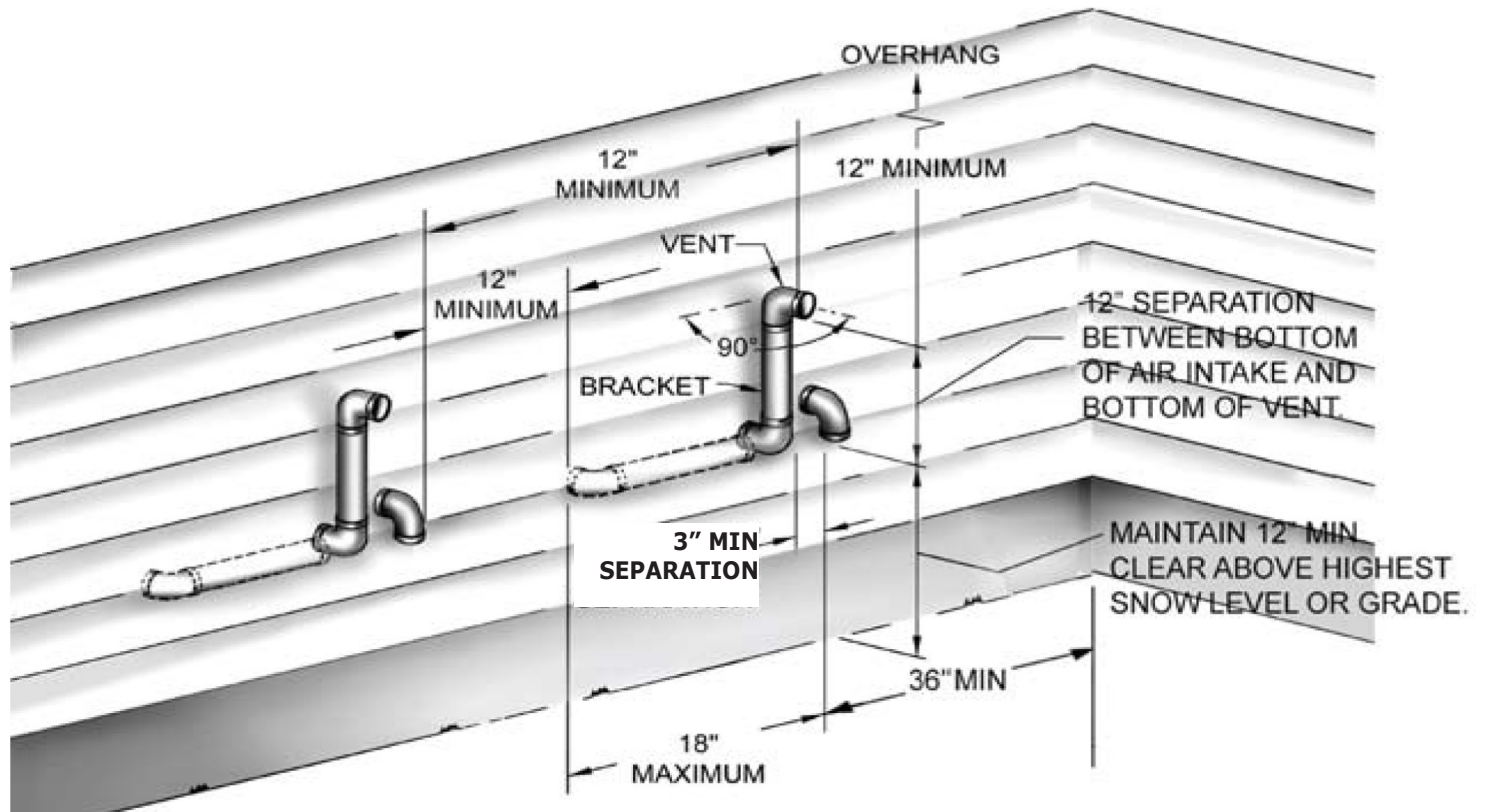
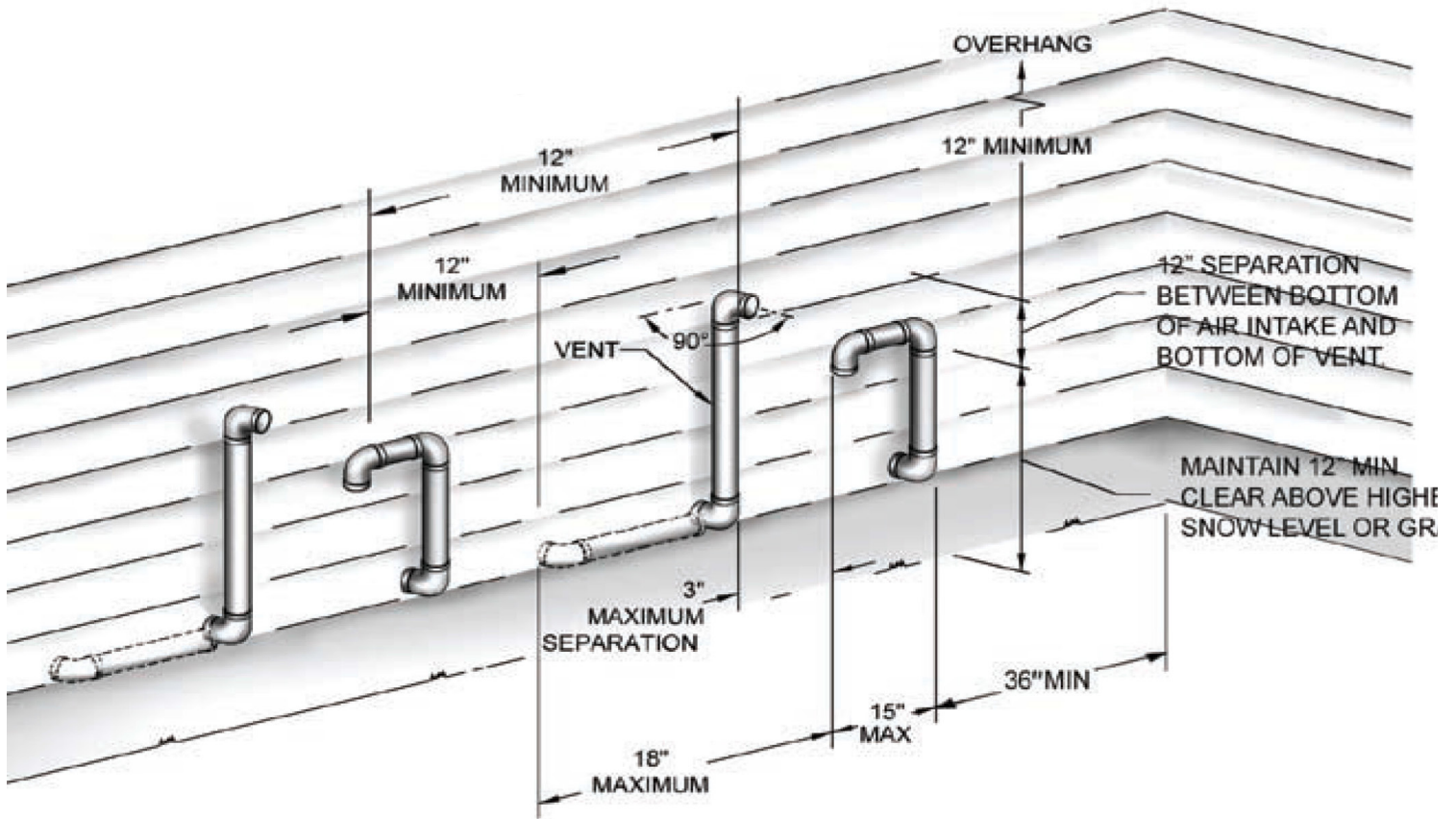

8 - COMBUSTION AIR AND VENT PIPE

Figure 6 -Roof Vent / Intake Terminations

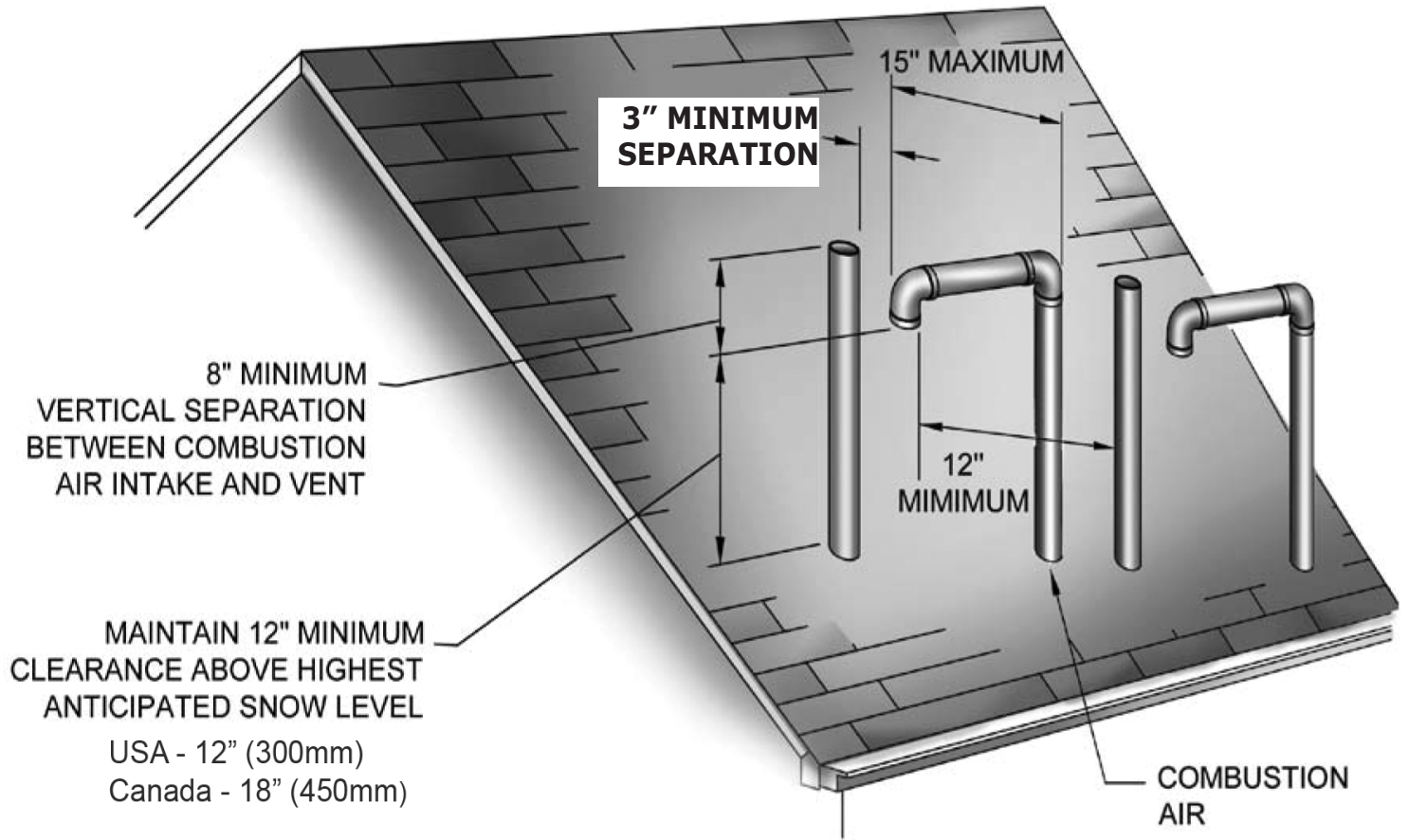
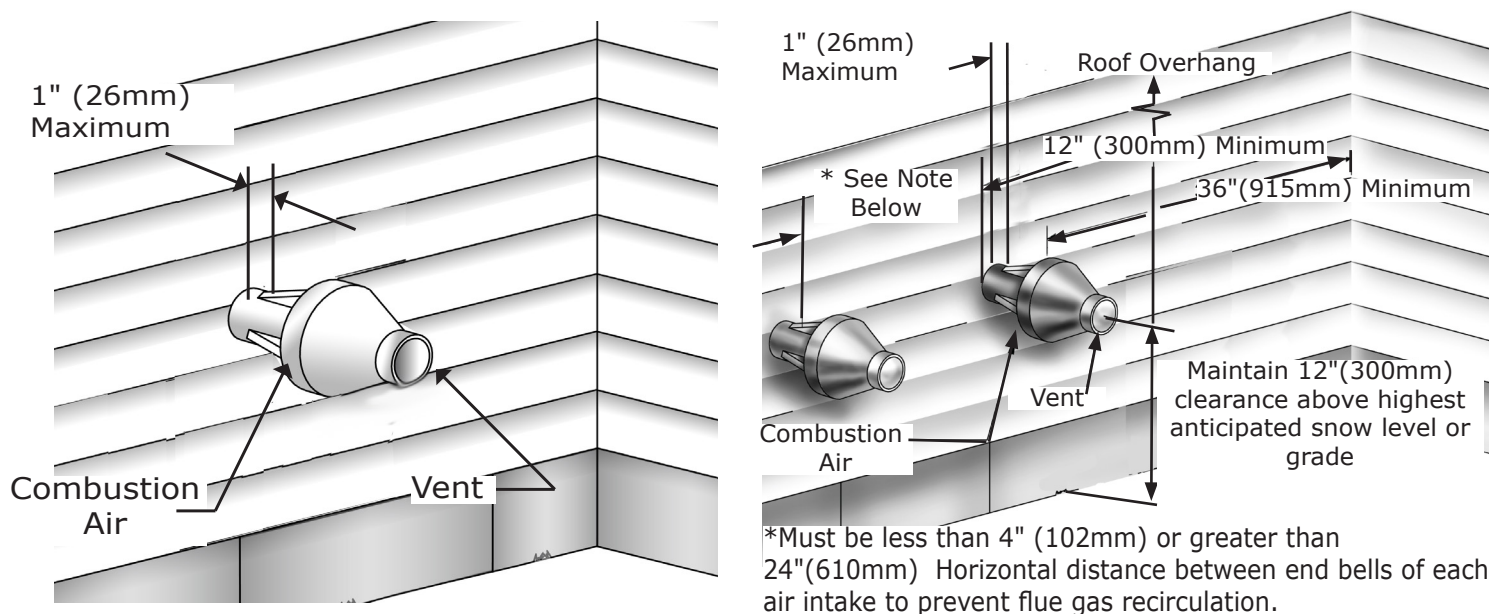

Figure 7 - Concentric Vent Terminations



8 - COMBUSTION AIR AND VENT PIPE

8.3 Installation

When transitioning from CPVC to PVC use Weld-On CPVC 724 or other cement approved for CPVC to PVC. In Canada ULC S636 approved cement must be used.

1. Recommend all pipes be cut, prepared, and pre-assembled before permanently cementing any joint.
2. Rigid supports cause excess noise in vent piping.
3. Attach combustion air intake piping to supplied 2" piping on CVI gas valve. Attach vent piping to furnished 2" CPVC preformed exhaust pipe. Use 2" x 3" adapter in vertical position on both air intake and vent pipe.
4. All pipe joints are to be water tight.
5. Working from boiler to outside, cut pipe to required length(s).
6. Deburr inside and outside of pipe. Remove all chips and shavings.
7. Chamfer outside edge of pipe for better distribution of primer and cement.
8. Clean and dry all surfaces to be joined.
9. Check dry fit of pipe and mark insertion depth on pipe.
10. After pipes have been cut and pre-assembled, apply cement primer to pipe fitting socket and end of pipe to insertion mark. Quickly apply approved cement to end of pipe and fitting socket (over primer). Apply cement in light, uniform coat on inside of socket to prevent buildup of excess cement. Apply second coat.
11. While cement is still wet, insert pipe into socket with 1/4 turn twist. Be sure pipe is fully inserted into fitting socket.
12. Wipe excess cement from joint. Continuous bead of cement will be visible around perimeter of properly made joint.
13. Handle pipe joint carefully until cement sets.
14. Support combustion air and vent piping minimum of every 5 feet using pre-formed metal hanging straps. Do not rigidly support pipes. Allow for movement due to expansion and contraction.
15. Slope combustion air and vent pipes toward boiler minimum of 1/4" per linear foot with no sags between hangers.
16. Use appropriate methods to seal openings where vent and combustion air pipes pass through roof or side wall.

Figure 8 - Concentric Vent w/ Dimensions

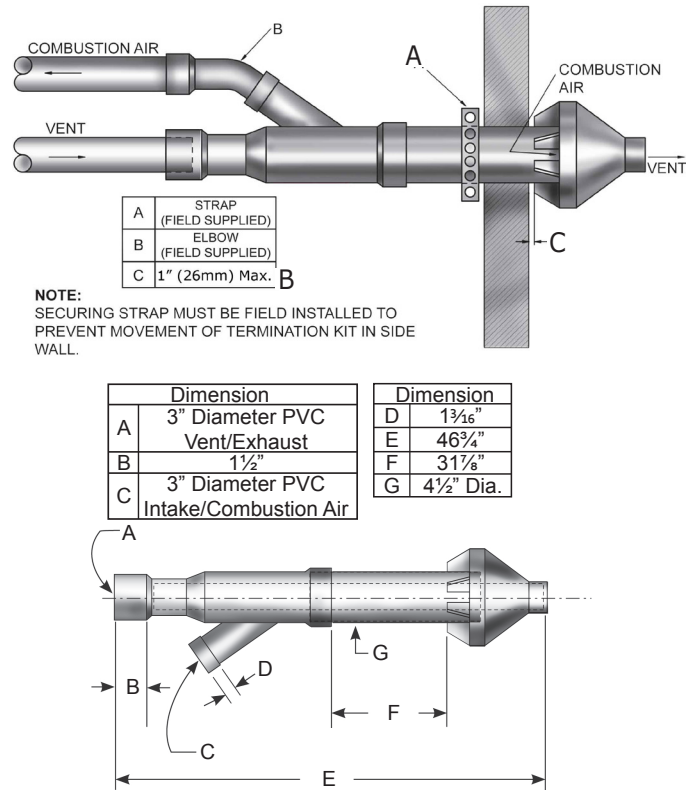
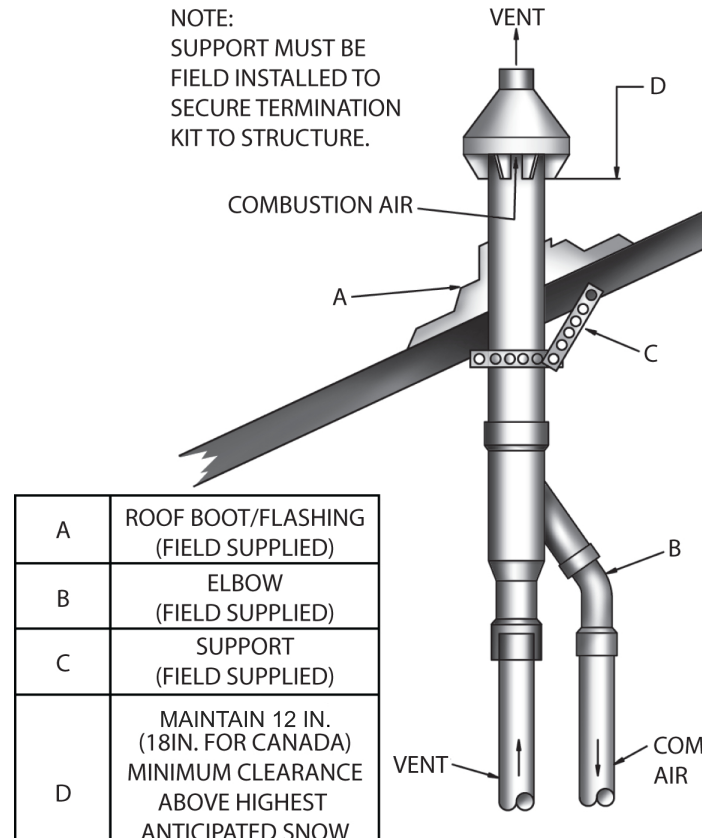

Figure 9 - Concentric Vent Roof Installation



CAUTION

WHAT TO DO IF YOU SMELL GAS

- Do not try to light any appliance.
- Do not touch any electrical switch; do not use any phone in your building.
- Immediately call your gas supplier from a neighbor's phone. Follow gas supplier's instructions.
- If you cannot reach your gas supplier, call the fire department.

9.1 Check Gas Supply

TABLE 6: GAS SUPPLY PRESSURE

Natural Gas	4" min. w.c.	10" max. w.c.
LP Gas	10" min. w.c.	14" max. w.c.

Check line pressure while unit is running in high fire mode.

- Gas pipe to boiler must be correct size for length of run and total Btuh input of all gas utilization equipment connected to it. See Table 7 for proper size.
- Verify your gas line complies with local codes and gas company requirements.
- Disconnect boiler and its individual shutoff valve from gas supply piping system during any pressure testing of system at test pressures in excess of 1/2 psig (3.5kPa).
- Isolate boiler from gas supply piping system by closing its manual shutoff valve during any pressure testing of gas supply piping system at test pressures equal to or less than 1/2 psig (3.5kPa).
- For proper boiler operation line pressure should be within minimum and maximum values in Table 6.
- Gas line enters boiler through left side panel. See page 2 Dimensions and Figure 10.

TABLE 7: GAS PIPING SIZES

Natural Gas				
Pipe Length	Pipe Capacity - BTU/Hr. Input Includes Fittings			
	1/2"	3/4"	1"	1 1/4"
20'	92,000	190,000	350,000	625,000
40'	63,000	130,000	245,000	445,000
60'	50,000	105,000	195,000	365,000

LP Gas				
Pipe Length	Pipe Capacity - BTU/Hr. Input Includes Fittings			
	Copper Tubing (O.D.)		Iron Pipe	
	5/8"	3/4"	1/2"	3/4"
20'	131,000	216,000	189,000	393,000
40'	90,000	145,000	129,000	267,000
60'	72,000	121,000	103,000	217,000

The length of pipe or tubing should be measured from the gas meter or propane second stage regulator.

9.2 Connecting Gas Piping

Boiler is equipped with 1/2" NPT connection on gas valve for supply piping and 1/2" NPT ball valve for manual shut off. Following rules apply:

1. Use only those piping materials and joining methods listed as acceptable by the authority having jurisdiction, or in the absence of such requirements,
 - **United States** - National Fuel Gas Code, ANSI Z223.1/NFPA 54.
 - **Canada** - Natural Gas and Propane Installation Code, CAN/CSA B149.1.
2. Use pipe joint compound suitable for liquefied petroleum gas on male threads only.
3. Refer to Figure 10 for general layout, which shows basic fittings needed. As shipped, gas line enters boiler through right side, as an option, it can be routed through either rear or left side panel.
4. Use ground joint unions.
5. Install sediment trap upstream of gas controls.
6. Use two pipe wrenches when making connection to the gas valve to keep it from turning.
7. Install manual shutoff valve in vertical pipe about 5' above floor outside boiler jacket in addition to shutoff valve supplied with boiler.
8. Tighten all joints securely.
9. Propane gas connections should only be made by licensed propane installer.
10. Two stage regulation should be used by propane installer.
11. Propane gas piping should be checked by propane installer.

⚠ DANGER

Fire Hazard. Do not use matches, candles, open flames, or other methods providing ignition source. Failure to comply will result in death or serious injury.

9.3 Leak Check Gas Piping

After making gas connections, open manual shutoff valve(s) and check all gas connections for leaks before placing boiler in operation.

Locate leakage using gas detector, noncorrosive detection fluid, or other leak detection method acceptable to authority having jurisdiction. Do not use matches, candles, open flames, or other methods providing ignition source.

Correct leaks immediately and retest.

Figure 10 - Gas Piping

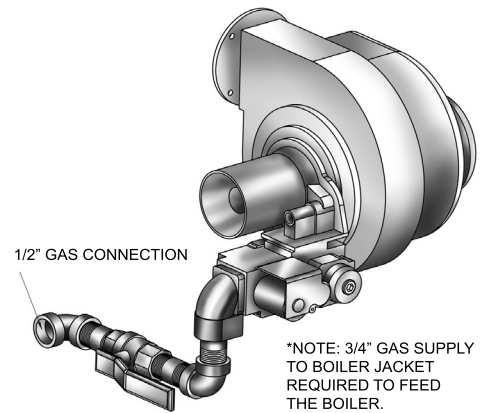

⚠ WARNING

Electrical shock hazard. Turn OFF electrical power supply at service panel before making electrical connections. Failure to do so could result in death or serious injury.

10.1 Codes

Electrically bond boiler to ground in accordance with requirements of authority having jurisdiction. In absence of such requirements, Refer to:

- USA - National Electrical Code, ANSI/NFPA 70.
- Canada - Canadian Electrical Code, Part I, CSA C22.1: Safety Standard for Electrical Installations.

10.2 Line Voltage Connections

1. Connect 120 VAC power wiring to line voltage terminal strip on boiler control panel.
2. Provide and install fused disconnect or service switch (15 amp recommended) as required by code.
3. Boiler circulator is shipped loose. Wire boiler circulator as shown in wire diagram label on boiler side panel. (CH L1, CH L2) CH = Central Heat
4. When connecting DHW circulator, connect wiring to line voltage terminal strip on boiler control panel. (DHW L1, DHW L2) DHW = Domestic Hot Water
5. Route all wires and conduits to openings in right jacket panel.

10.3 Line Voltage Monitor

- Boiler is factory equipped with line voltage monitor that continuously monitors incoming voltage for errors.
- When incoming line voltage is greater than 12% or less than 8% of nominal voltage monitor will flash indicating fault.
- 6 Seconds after line voltage is back within acceptable range green light will illuminate on monitor and boiler will restart. Line voltage monitor is factory set at 115 VAC.

It is important that monitor be set to voltage present at installation site by following these directions:

1. Using multimeter, locate wall outlet nearest to boiler and determine line voltage present on site.
2. Disconnect power to boiler.
3. Remove boiler cover.
4. Locate line voltage monitor mounted to display panel.
5. Remove line monitor protective cover.
6. Using small screwdriver turn left dial until arrow points at input voltage measured during step 1.
7. Set right dial at 0.1 minute, this is factory setting.
8. Reinstall line monitor protective cover.
9. Replace boiler cover and re-connect power to unit.

Figure 11 - Line Voltage Monitor

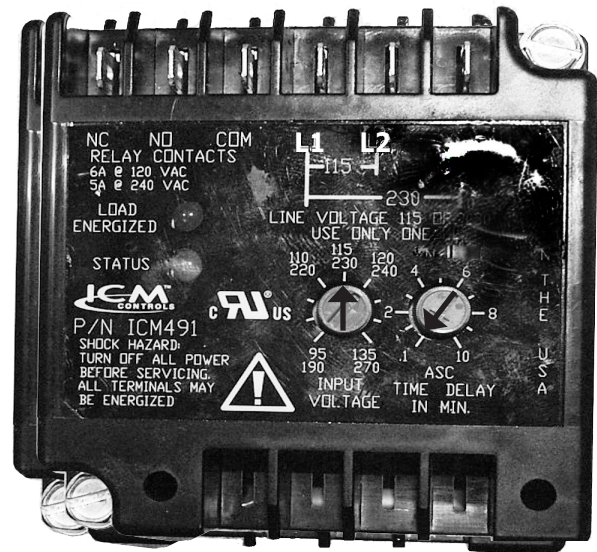

10.4 Low Voltage Connections

1. Connect low voltage wiring to low voltage terminal strip as shown in boiler wiring diagram.
2. Route all low voltage wires through opening on right jacket panel. Use shielded cable.

NOTICE

Use only N.E.C. Class 1 wiring. If replacing original boiler wiring, use only type 105°C wire or equivalent.

See Piping and Wiring Appendix for wiring and piping diagrams.

10.6 Thermostat

1. Connect room thermostat or end switch (isolated contact only) between terminals T1 and T2.
2. Install thermostat on inside wall away from influences of drafts, hot or cold water pipes, lighting fixtures, televisions, sun rays, or fireplaces.
3. Thermostat anticipator (if applicable)
 - A. Set for 0.1 amps if connected directly to boiler.
 - B. Set to match total electrical power requirements of connected devices if connected to relays or other devices. See device manufacturers' specifications and thermostat instructions for details.

10.7 Outdoor Temperature Sensor

1. Connect outdoor temperature sensor between terminals A1 and A2 to enable outdoor reset operation of the boiler. If fixed temperature operation is required, do not install outdoor sensor.
2. Mount sensor on exterior wall, shielded from direct sunlight or flow of heat or cooling from other sources.
3. If desired, install a summer/winter switch across terminals A1 and A2. When the switch is closed, the boiler (space heating) circulator is disabled.
4. Route sensor wires through the holes provided on the right jacket panel of the boiler.

10.8 DHW Limit Control

Connect storage indirect water heater (DHW) limit control between terminals DHW T1 and DHW T2.

See Piping and Wiring Appendix for wiring and piping diagrams.

AVOID THE FOLLOWING	
Dead Spots	Corners Alcoves Behind doors
Cold Spots	Concealed pipes or ducts Stairwells - drafts Unheated rooms on the other side of the wall
Hot Spots	Concealed pipes Fireplaces TVs or radios Lamps Direct sunlight Kitchens

11 - CONTROLS AND ACCESSORIES

Refer to Repair Parts Manual for illustrations, and Control Manual and Troubleshooting Guide for detailed sequence of operation and troubleshooting guide.

11.1 Aluminum Heat Exchanger

- Monoblock design cast aluminum heat exchanger eliminates need for mating sections eliminates leaks between sections.
- Cast aluminum has better heat transfer properties which leads to higher efficiency and cooler exhaust temperatures.
- Cooler exhaust temperatures create condensation of flue gas, which would cause corrosion in traditional cast iron heat exchangers.

11.2 Main Power Switch

Main power switch is located on the display panel. Main power switch is illuminated when receiving power and in ON position.

11.3 Modulating Boiler Control

Integrated modulating control senses load necessary to heat structure and therefore uses less fuel than conventional fixed firing rate boiler when there is lower than peak demand for heat.

Control senses supply water, return water, and outside air temperatures. If outside air sensor is connected and calculates load on system it adjusts firing rate to deliver amount of heat needed at that particular time.

11.4 NTC Sensors

NTC sensors measure supply water, return water, and outside air temperature. Configured to operate with modulating boiler control.

11.5 Modulating Blower

- Modulating blower provides introduction of gas/air mixture through burner and into combustion chamber then out exhaust vent where combustion products are discharged to outdoors.
- Blower is designed to communicate with modulating control to run at variable speeds dependent on heating system heat load.
- Variable speeds create pressures felt by gas valve and gas/air mixer that dictate how much fuel is introduced to combustion process.

11.6 Gas Control Valve

- Boiler gas controls have been developed for domestic heating appliances with premix burners and automatic direct burner ignition and are suitable for natural and LP gas.

- Gas controls perform all functions required to safely regulate gas flow to main burner of boiler.
- Gas valve is directly connected to gas/air mixer.

11.7 Gas/Air Mixer

Venturi design of gas/air ensures correct mixture of air and gas.

11.8 Modulating Burner

Burner is designed to operate over full range of input. Burner can operate under normal (blue flame) and infrared conditions.

11.9 Direct Spark Igniter (DSI)

Boiler uses DSI to ignite fuel/air mixture in combustion chamber and sense flame during operation. DSI is durable, reliable, and resists breakage.

11.10 Manual Reset Low Water Cut Off

- Installed integral low water cut off (LWCO) must be manually reset if there is a low water condition.
- LWCO senses water through probe at boiler top that sends signal through water to ground. If the signal is not sensed LWCO enters lockout mode that disables boiler.
- LWCO in normal mode illuminates red indicator light on LWCO panel in boiler.
- During low water condition, red light goes out and LWCO and control reset buttons on display panel must be pressed to reset LWCO.

11.11 Normally Closed LWCO Switch

- Round button switch located next to digital display is normally closed and spring loaded, when depressed will open, when pressure is removed closes.
- Switch is used as manual reset for LWCO. LWCO will remain in lockout when tripped until water level reaches probe and switch is pressed to open state and then released to closed state, which sends signal to LWCO to resume normal operation.
- Boiler control reset button must then be pressed to reset from low water condition. LWCO switch and control reset button are located on boiler panel display.

11.12 High Limit Control

- High limit control is safety limit control provides protection for boiler and heating system from unsafe operating conditions which could damage the boiler.

11 - CONTROLS AND ACCESSORIES

- High limit control is mounted in 1/2" NPT control well and 3/4" X 1/2" bushing on top of front boiler section at hot water outlet.
- High limit control is tied in with boiler control and is factory set at 180°F (82°C) water temperature.
- High limit setpoint is field adjustable and may be set anywhere between 100°F (38°C) and 180°F (82°C), with maximum high limit setpoint not exceeding 180°F (82°C). Field high limit setpoint adjustment for each installation depends on heating system requirements.
- High limit control automatically resets when boiler water temperature decreases below high limit setpoint value by differential setpoint value. Adjustable differential from 5°F (3°C) to 30°F (17°C).
- Boiler operating temperature (temperature curve) is calculated and set in boiler control parameters.

11.13 Casting Temperature Safety Switch

- Casting temperature safety switch, 230°F (110°C) setpoint, shuts off power to boiler control in event of boiler lack of or loss of water.
- Casting temperature safety switch is installed on top of aluminum boiler section behind supply piping.
- Failure code is displayed on digital readout. Fault requires manual reset of casting temperature safety switch to restart boiler. Press reset on user interface panel also.
- Verify boiler is properly filled with water and no air is trapped in top of casting (check cap on Cam Vent at heat exchanger) before resetting.

WARNING

Burn and scald hazard. Never run cold water into a hot, empty boiler. Failure to follow these instructions could result in death or serious injury

11.14 Circulator Pump

- Circulating pump moves water through closed loop supply and return piping systems, terminal heating equipment (finned tube radiators, etc.) and back through boiler for reheating.
- Properly size circulator pump to overcome frictional losses (usually measured in feet of water, also referred to as "pump head loss") of supply and return piping systems and boiler to provide required hot water flow rates.
- Circulator pump is furnished in carton within boiler cabinet.
- Locate circulator(s) on downstream ("pumping away") side of expansion tank.

11.15 Blocked Vent Safety Assembly

Blocked vent safety assembly incorporates two pressure switches designed to discontinue operation of boiler if there is a problem with blower or venting system.

The normally open switch closes upon initiation of blower and functions as air proving switch.

The normally closed switch opens if there is a blockage in combustion air intake or exhaust vent pipes.

11.16 Drain Valve

Manual drain valve drains water in heating system, including boiler, hot water supply and return piping systems installed above drain valve.

Drain valve is installed in return piping at bottom front of boiler section. Any piping installed below elevation of drain valve requires additional drain valves to be installed at low points in piping system in order to drain entire system.

WARNING

Burn and scald hazard. Safety relief valve could discharge steam or hot water during operation. Install discharge piping per these instructions.

11.17 Safety Relief Valve

- Each boiler must have a properly sized and installed American Society of Mechanical Engineers (ASME) rated safety relief valve.
- Furnished safety relief valve automatically opens at 30 psig pressure to relieve strain on boiler and heating system from increasing pressure.
- Pipe Safety relief valve discharge with same size pipe as valve discharge opening to open drain, tub or sink, or other suitable drainage point not subject to freezing.

11.18 External Condensate Pump (optional)

For installations where there is no floor drain or other appropriate drainage receptacle available to receive condensate from boiler, external float activated condensate pump with integral sump is required. Condensate pump can be piped to remote tie in point to sanitary sewer system. For this application, boiler must be installed so that proper pitch of piping to external condensate reservoir (sump) can be accomplished. Use wood frame or concrete blocks to raise boiler as required for proper installation.

11.19 Concentric Vent/Air Intake Termination (Optional)

Optional concentric vent/air intake termination utilizes single opening per each appliance through wall or roof of structure.

Water Treatment And Freeze Protection - See Appendix B

12.1 Filling Boiler With Water And Purging Air

1. Systems With Diaphragm Type Expansion Tanks

- A. Close all zone service valves on supply and return piping. Open feed valve and fill boiler with water. Verify air vent is open. Hold relief valve open until water runs air free for five seconds to rapidly bleed air from boiler, then let relief valve snap shut.
- B. Open zone service valve on supply pipe for first zone. Open purge valve on first zone. Feed water will fill zone, pushing air out purge valve. Close purge valve when water runs air free. Close zone service valve.
- C. Repeat step 2 for all remaining zones.
- D. Open all service valves. Any air remaining trapped in return lines between service valves and boiler will be pushed towards air vent when boiler is placed in operation.
- E. Inspect piping system and repair any leaks immediately.

2. Systems With Conventional Closed Type Expansion Tanks

- A. Close all zone service valves on supply and return piping and close expansion tank service valve. Drain expansion tank. Open feed valve and fill boiler with water. Hold relief valve open until water runs air free for five seconds to rapidly bleed air from boiler, then let relief valve snap shut.
- B. Open zone service valve on supply pipe for first zone. Open purge valve on first zone. Feed water will fill zone, pushing air out purge valve. Close purge valve when water runs air free. Close zone service valve.
- C. Repeat step 2 for all remaining zones.
- D. Open expansion tank service valve and tank vent. Fill tank to proper level and close tank vent. Remove handle from expansion tank service valve so it is not accidentally closed.
- E. Open all service valves. Any air remaining trapped in return lines between service valves and boiler will be pushed towards expansion tank when boiler is placed in operation.
- F. Inspect piping system. Repair any leaks immediately.

NOTICE

Do not use stop leak compounds. Repair leaks in threaded connections of aluminum boiler sections. Aluminum threads do not seal themselves.

13 - OPERATING INSTRUCTIONS

13.1 Lighting Instructions

For Your Safety Read Before Operating!!

⚠ WARNING

If you do not follow these instructions exactly, a fire or explosion may result causing property damage, personal injury or loss of life.

- This appliance is equipped with an ignition device which automatically lights burner. **Do NOT try to light this burner by hand.**
- Before operating smell all around appliance area for gas. Be sure to smell next to floor because some gas is heavier than air and will settle to the floor.
- **Use only your hand to turn the gas shutoff valve.** Never use tools. If valve will not turn by hand, do not try to repair it, call a qualified service technician. Force or attempted repair may result in fire or explosion.
- **Do not use this appliance if any part has been under water.** Immediately call a qualified service technician to inspect appliance and to replace any part of control system and any gas control which has been under water.

Stop! Read Safety information above.

13.2 Operating Instructions

1. Set thermostat to lowest setting.
2. Turn off all electrical power to appliance.
3. Boiler does not have a pilot. It is equipped with ignition device which automatically lights burner. Do not try to light this burner by hand!
4. Remove front jacket panel.
5. Turn off gas ball valve. Valve handle should be perpendicular to gas pipe.
6. Wait 5 minutes for any gas to clear. Then smell for gas, including near floor. If you smell gas, STOP! Follow instructions on previous page "What To Do If You Smell Gas." If you do not smell gas, go to next step.
7. Turn gas ball valve to "on" position. Handle on valve should be parallel to gas pipe. See Figure 12.
8. Replace front jacket panel.
9. Turn on all electrical power to appliance.
10. Set thermostat to desired setting.
11. If boiler will not operate, follow instructions "To Turn Off Gas To Appliance" and call your service technician or gas supplier.

⚠ CAUTION

WHAT TO DO IF YOU SMELL GAS

- Do not try to light any appliance.
- Do not touch any electrical switches; do not use any phone in your building.
- Immediately call your gas supplier from a neighbor's phone. Follow the gas supplier's instructions.
- If you cannot reach your gas supplier, call the fire department.

13.3 To Turn Off Gas To Appliance

1. Set thermostat to lowest setting.
2. Turn off all electric power to appliance if service is to be performed.
3. Remove front jacket panel.
4. Turn gas ball valve off, handle should be perpendicular to gas pipe.
5. Replace front jacket panel.

Figure 12- Gas Valve

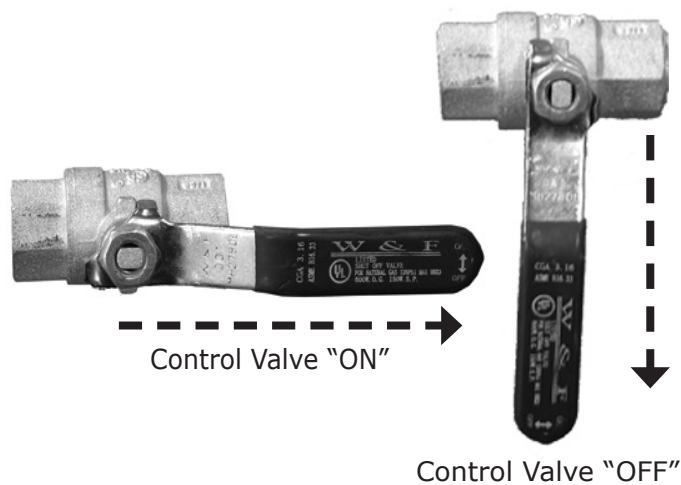

14 - MAINTENANCE AND CLEANING

Acidic nature of flue gases condensing on aluminum boiler sections cause formation of aluminum oxide. This oxide formation is normal, and represents negligible mass of aluminum consumed by oxidation during life of boiler. If left unchecked, this buildup may eventually cause blockage of flue gas passages in boiler sections, reducing efficiency, and ultimately shutting boiler down due to lack of combustion air flow, or drainage of condensate.

Regular service and maintenance by qualified service agency must be performed at least once every 12 months to assure safe, trouble free operation and maximum efficiency.

14.1 Beginning of each heating season

1. Schedule annual service call by qualified service agency which includes:
 - Examine flue passages in heat exchanger, burner, and condensate lines, and clean (if necessary) follow instructions in "Annual Examination and Cleaning of Boiler Components" page 26.
 - Inspect venting and air intake system for proper operation, immediately repair or replace any sign of deterioration or leakage, and verify proper reassembly and resealing of system.
 - Check for and remove any obstruction to flow of combustion air or venting of flue gases.
 - Follow "Operating Instructions" Section 13. Follow "Boiler Startup" Section 5 and "Checkout Procedures And Adjustments", section 6 of Control Manual and Troubleshooting Guide."
 - Inspect condensate drain line for proper operation. Check for deteriorated or plugged condensate drain line.
 - Check all gasketed joints for leakage. Tighten bolts or replace gaskets as needed.
 - Remove jacket front and top panels, check for piping leaks around safety relief valve and other fittings, and repair if found. Do not use stop leak compounds.
2. Verify boiler area is free from combustible materials, gasoline, and other flammable vapors and liquids.
3. Circulator pump and blower fan motor furnished with boiler are permanently lubricated from factory and require no further lubrication. Additional or non-factory supplied pumps and/or motors should be lubricated according to pump and/or motor manufacturer's instruction.

14.2 Daily During Heating Season

1. Check for and remove any obstruction to flow of combustion air or venting of flue gases.
2. Check boiler area is free from combustible materials, gasoline, and other flammable vapors and liquids.

14.3 Monthly During Heating Season

1. Remove jacket front and top panels and check for piping leaks around safety relief valve and other fittings. If found, contact qualified service agency. DO NOT use stop leak compounds.
2. Test safety relief valve. Refer to valve manufacturers instructions packaged with safety relief valve.
3. Visually inspect venting and air intake system for proper operation. If vent or air intake show any signs of deterioration or leakage, contact qualified service agency to repair or replace them immediately and to insure proper reassembly and resealing of system.
4. Visually inspect condensate drain pipe for proper operation. If drain pipe shows any signs of blockage, leakage, or deterioration contact qualified service agency to clean, repair, or replace it immediately.
5. Check air vent(s) for leakage.
6. Periodic inspection of low water cut off is necessary, including flushing of float type devices. Refer to low water cut off manufacturer's specific instructions.

14 - MAINTENANCE AND CLEANING

WARNING

Following service procedures must be performed by qualified service agent. Boiler owner shall not attempt these steps. Failure to do so could result in death or serious injury.

NOTICE

Perform regular service and maintenance by qualified service agency at least once every 12 months to assure safe, trouble free operation and maximum efficiency.

NOTICE

Verify proper operation after servicing.

14.4 Annual Shut Down Procedure

1. Turn off gas to boiler as described in "To Turn Off Gas To Appliance" Section 13.3 page 24.
2. If heating system is to remain out of service during freezing weather and does not contain antifreeze, drain system completely. If boiler will be exposed to freezing temperatures, drain condensate lines.

14.5 Annual Examination And Cleaning Of Boiler Components

1. Following service procedures must be performed by qualified service agency. Boiler owner should not attempt these steps.
2. Before servicing, turn off electrical power to boiler at service switch. Close manual gas valve to turn off gas supply to boiler.
3. Examine flue passages by removing blower/burner assembly from casting. Procedure for examining and cleaning the burner is described below.
4. Clean any buildup of sediment or aluminum oxide (white powdery or flaky substance) in flue passages as follows:
 - A. Remove jacket front and top panels.
 - B. Confirm manual gas valve is closed and disconnect gas line to gas valve at union. Disconnect pressure switch hoses to gas valve and air inlet.
 - C. Disconnect wires to gas valve and igniter.
 - D. Loosen but do not remove five nuts attaching blower adapter assembly to boiler.
 - E. Remove two igniter screws and carefully remove igniter.
 - F. Remove five nuts and remove blower adapter assembly, burner, and gaskets.
5. Inspect condensate trap. Clean out any foreign material visible in condensate lines.
 - A. Inspect for sediment or blockage.
 - B. Flush out with water or vacuum.
 - C. Follow instructions in, "Filling Condensate Trap With Water."
6. Inspect flue connector.
 - A. Loosen clamp on vent tee side of 2" flexible coupling that connects vent tee to exhaust port.
 - B. Inspect interior of vent tee. Clean any buildup of sediment on inside surface.
 - C. Reconnect 2" flexible coupling to vent tee.
- G. Aluminum oxide deposits are water soluble and may be rinsed away by inserting hose into burner opening of casting and slowly run water through flue side of boiler and out condensate drain. Debris rinsed away by this method will exit through condensate drain. Be wary of drain lines getting clogged and causing water to back up in the bottom of casting.
- H. Use flexible handle nylon brush to loosen sediment and aluminum oxide on all accessible heating surfaces of boiler. Take care not to get brush stuck in heat exchanger.
- I. After brushing and rinsing, remove any remaining loosened sediment using shop vacuum with snorkel attachment.
- J. Inspect burner for any foreign matter in flame ports or inside burner. Remove any foreign matter by blowing with compressed air or vacuuming. If burner cannot be cleaned, it must be replaced.
- K. Reinstall burner and gaskets and position blower adapter assembly over studs. **Install five nuts do not tighten.** Reinstall igniter and igniter gasket and fasten with two screws. **Tighten five nuts holding blower adapter assembly.**
- L. Connect gas line to gas valve, pressure switch hose to gas valve and air inlet assembly, igniter wires, and gas valve wires.

APPENDIX A - BOILER PIPING AND WIRING

Electrical Wiring Diagram

ELECTRICAL WIRING DIAGRAM (DIAGRAMME DE CÂBLAGE ÉLECTRIQUE)

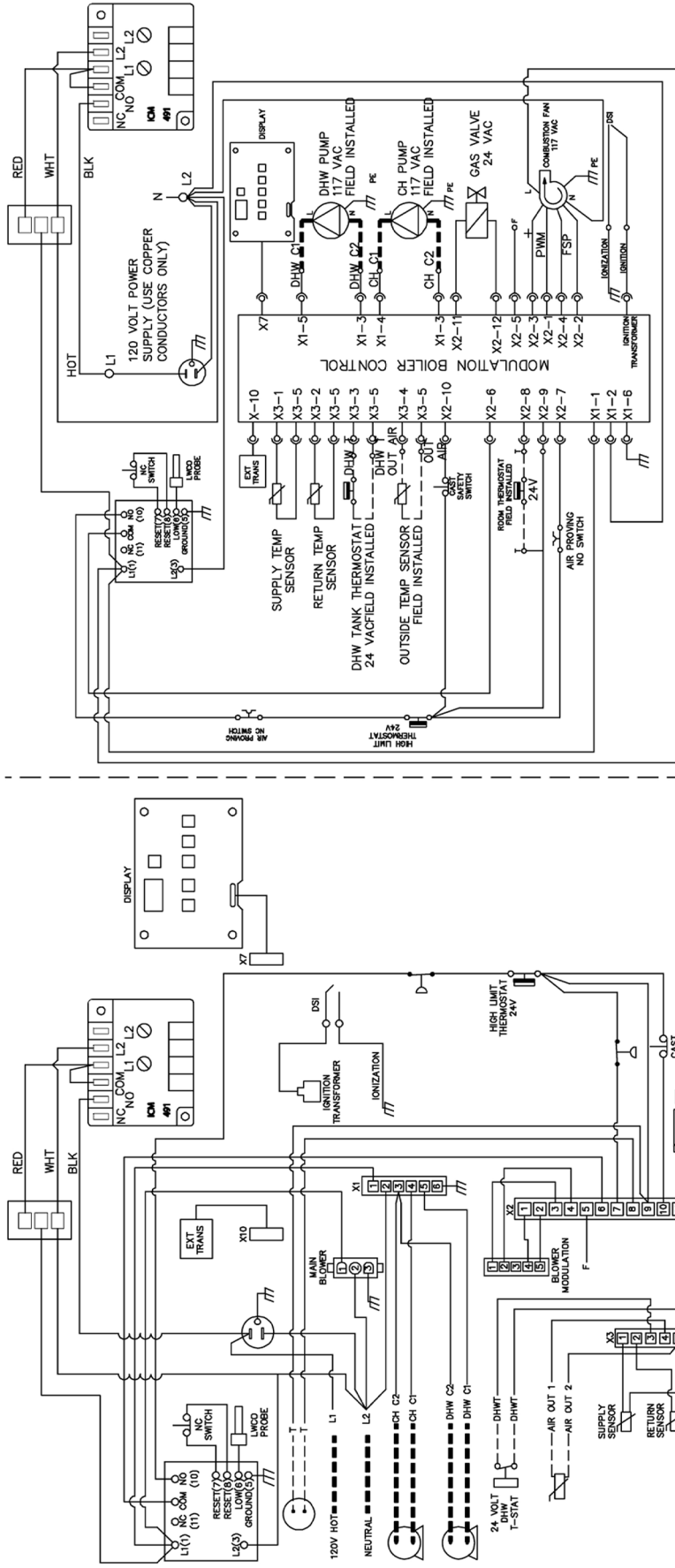

COMPONENT CODING (CODE DES COMPOSANTES)

COMPONENT CODING (CODE DES COMPOSANTES)	WIRING (CÂBLAGE)
TH-1 THERMOSTAT (MILLIVOLT)	— LINE VOLTAGE BY FACTORY / LIGNE DE VOLTAGE PAR L'USINE
TH-2 THERMOSTAT (24 VOLT)	— LOW VOLTAGE BY FACTORY / BAS VOLTAGE PAR L'USINE
TH-3 THERMOSTAT (LINE VOLTAGE / (VOLTAGE DE LIGNE))	— LOW VOLTAGE BY INSTALLER / LIGNE DE VOLTAGE PAR L'INSTALLATEUR
TR-1 TRANSFORMER (200V/24V 40VA)	— LOW VOLTAGE BY INSTALLER / BAS VOLTAGE PAR L'INSTALLATEUR
TR-2 TRANSFORMER (200V/24V 50VA)	
MGV MILLIVOLT GAS VALVE / SOUPAPE À GAZ MILLIVOLT	
LGV 24 VOLT GAS VALVE / SOUPAPE À GAZ 24 VOLT	
LGW 24 VOLT GAS VALVE / SOUPAPE À GAZ 24 VOLT	
PS PRESSURE SWITCH / INTERRUPTEUR DE PRESSION	
MR-PS MANUAL RESET PRESSURE SW. / REMISE EN MARCHÉ	
SD STACK DAMPER / REGISTRE DE LA CHEMINÉE	
— CONTROL TERMINAL / BORNE DU CONTRÔLE	
1 K RELAY CONTACTS / CONTACTS DU RELAIS	
1 K2 RELAY CONTACTS / CONTACTS DU RELAIS	
LS LIMIT SWITCH / INTERRUPTEUR DE LIMITE	
F FLAME SENSING / FLAMME SENSING	
MS MANUAL SWITCH / INTERRUPTEUR MANUEL	
CS CIRCUIT BREAKER / CIRCUIT LÉVÉ	
ECC ENERGY CUT-OFF / COUPE-ÉNERGIE	
LMCO LOW WATER CUT-OFF / POUR FERMER L'EAU	
EMF ELECTRIC WATER FEEDER / ALIMENTEUR ÉLECTRIQUE D'EAU	
PG POWER GENERATOR / GÉNÉRATEUR	
PSC PILOT SAFETY COIL / BOBINE DE SÛRETÉ DE LA VELLEUSE	
— WIRE CONNECTION / RACCORD DES FILS	

NOTE: 1. SWITCHES ARE SHOWN IN POSITION TAKEN DURING HEATING CYCLE. / (LES INTERRUPTEURS SONT MONTRÉS EN POSITION DE CYCLE DE CHAUFFANT).
 2. IF ANY OF THE ORIGINAL WIRING SUPPLIED WITH THE BOILER IS REPLACED, IT MUST BE REPLACED WITH LIKE WIRE SIZE AND TYPE OF INSULATION OR EQUIVALENT.
 (SI AUCUN DES FILS ORIGINAUX FOURNIS AVEC LA CHAUDIÈRE EST REMPLACÉ, IL DOIT ÊTRE REMPLACÉ PAR UN AUTRE FIL DE MÊME TYPE D'ISOLATION OU L'ÉQUIVALENT).

* NOT ALL COMPONENTS LISTED ARE USED IN ALL CONTROL SYSTEMS. (LES COMPOSANTES ÉNUMÉRÉES NE SONT PAS TOUTES UTILISÉES DANS TOUS LES SYSTÈMES DE CONTRÔLES.)

APPENDIX A - BOILER PIPING AND WIRING

Boiler Control Wiring Diagram: Single Zone System With Domestic Hot Water Priority

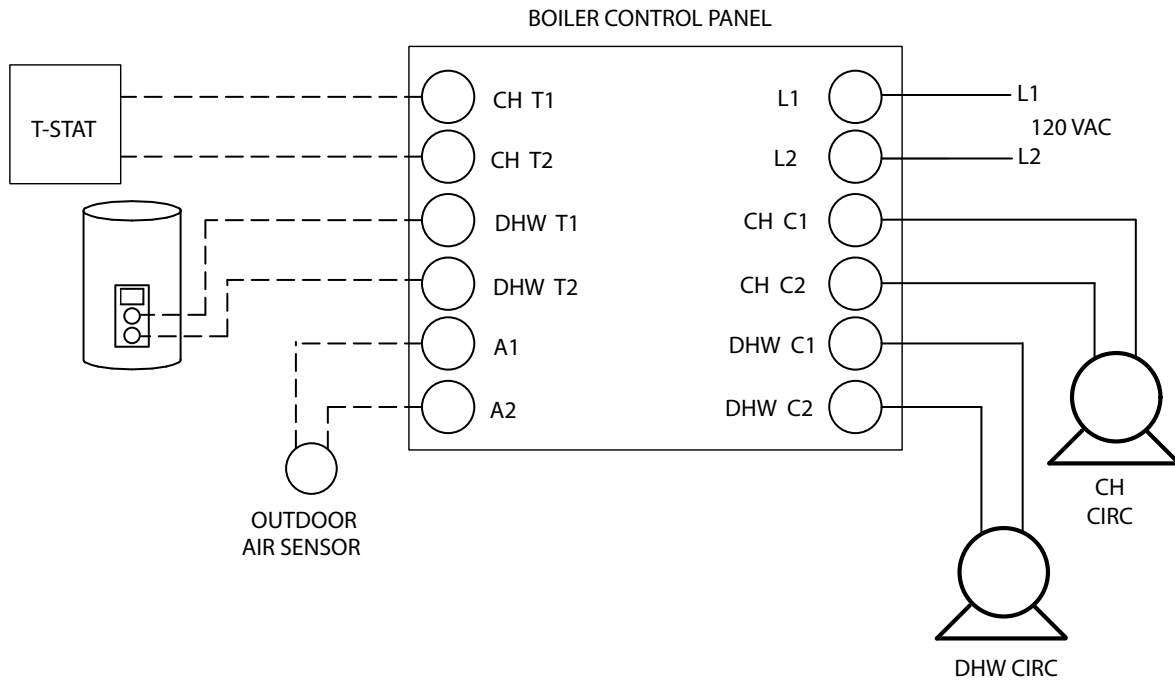

Note: CH & DHW Circulator connections on boiler only support pump with 1 amp rating or less.

APPENDIX A - BOILER PIPING AND WIRING

Piping Diagram 1: Single Zone System With Domestic Hot Water Priority

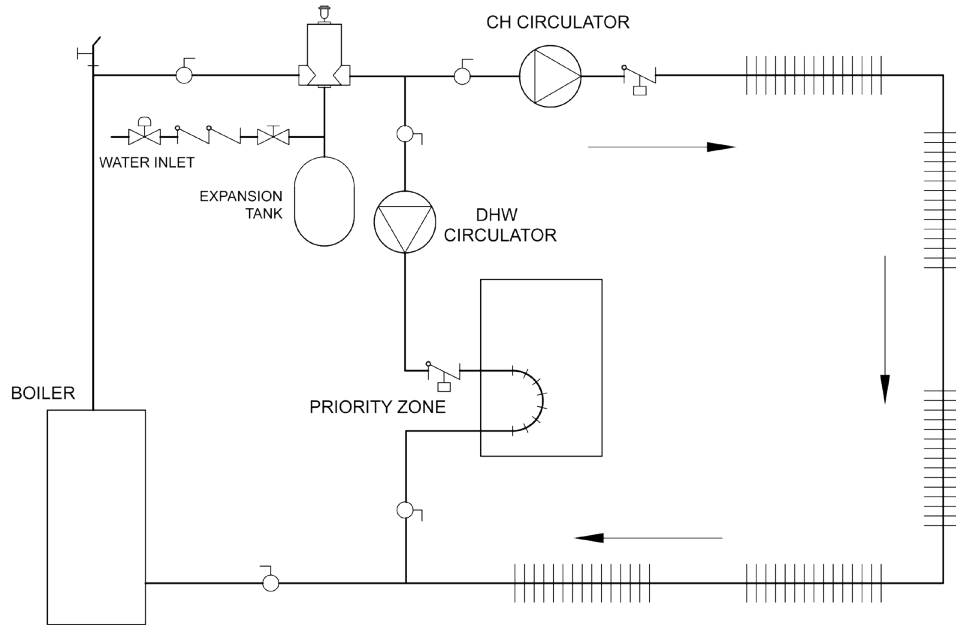

NOTE: NOT RECOMMENDED FOR ANTIFREEZE APPLICATIONS

Wiring Diagram 1 : Single Zone System With Domestic Hot Water Priority

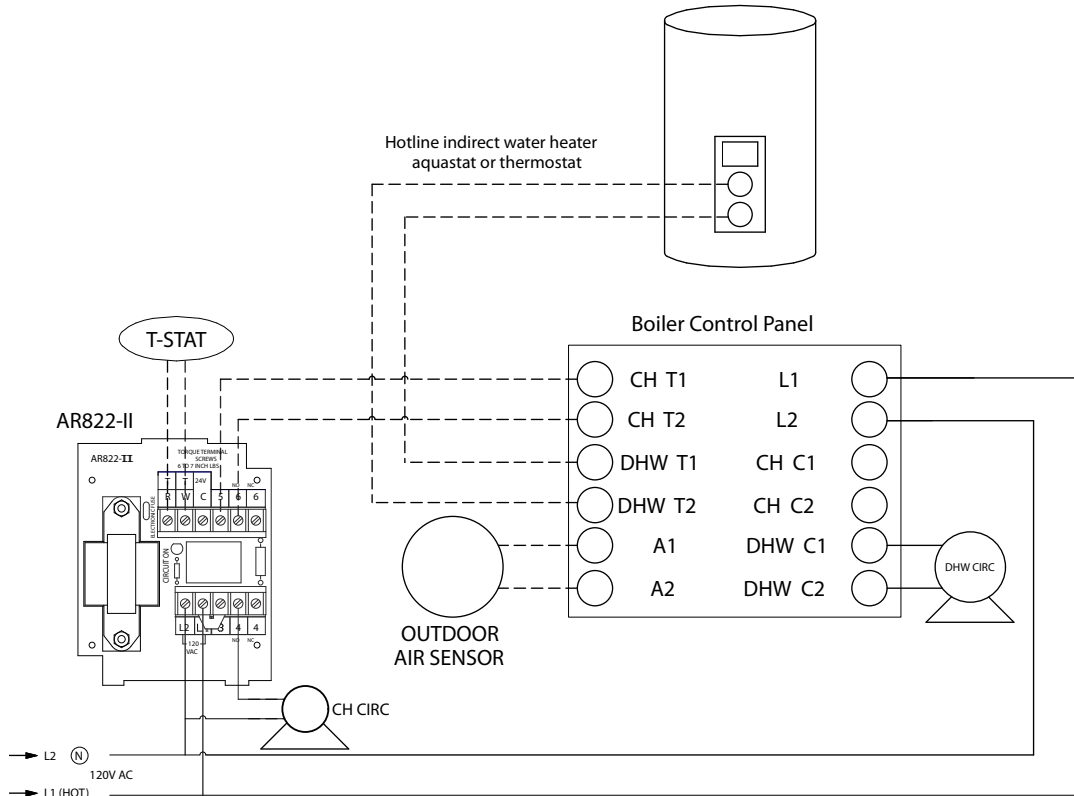

Piping Diagram 2 : Multizone Piping With Zone Valves And Domestic Hot Water Priority (With Zone Valve)

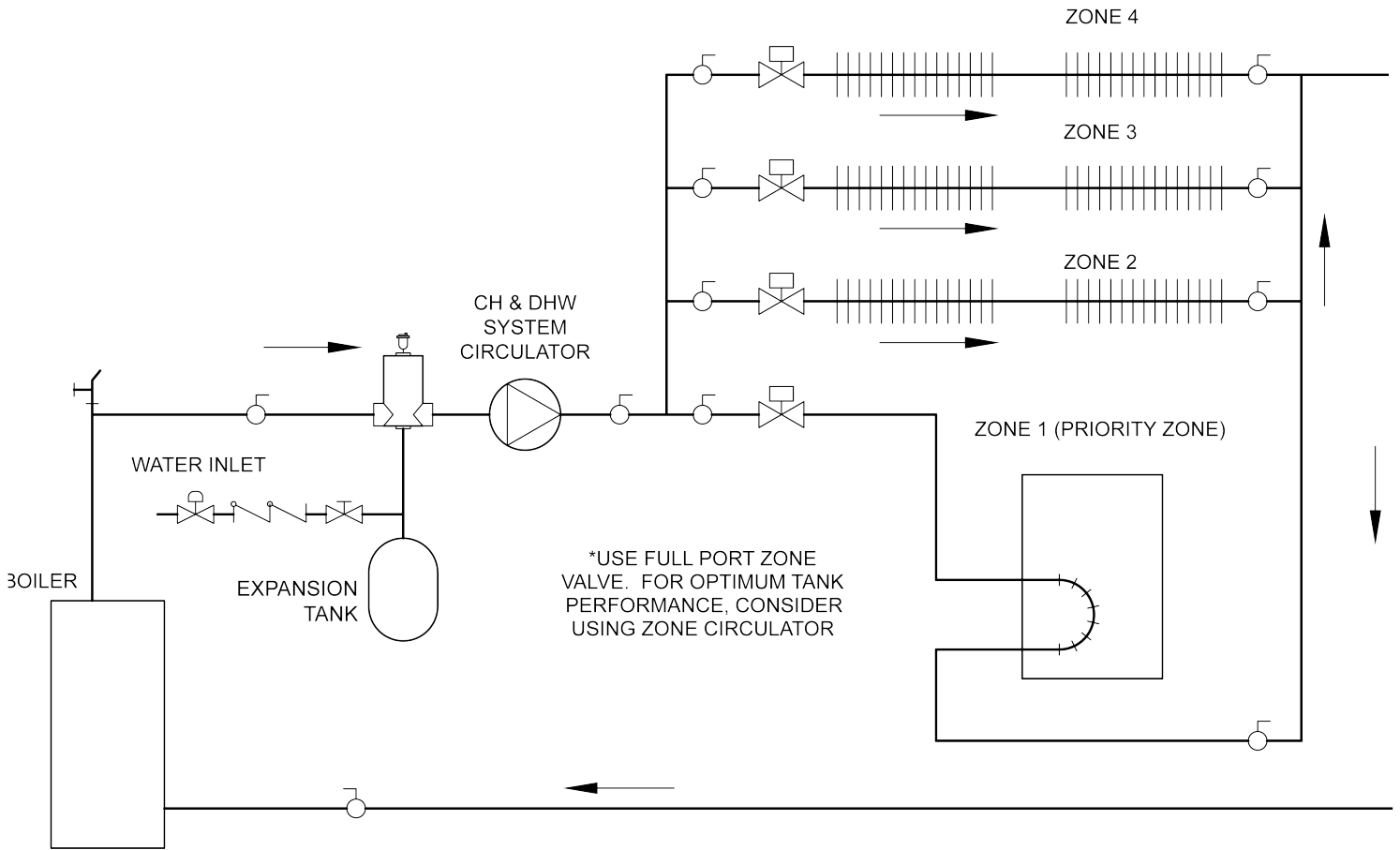

NOTE: NOT RECOMMENDED FOR ANTIFREEZE APPLICATIONS

APPENDIX A - BOILER PIPING AND WIRING

Wiring Diagram 2: Multizone Wiring With Zone Valves And Domestic Hot Water Priority (With Zone Valve)

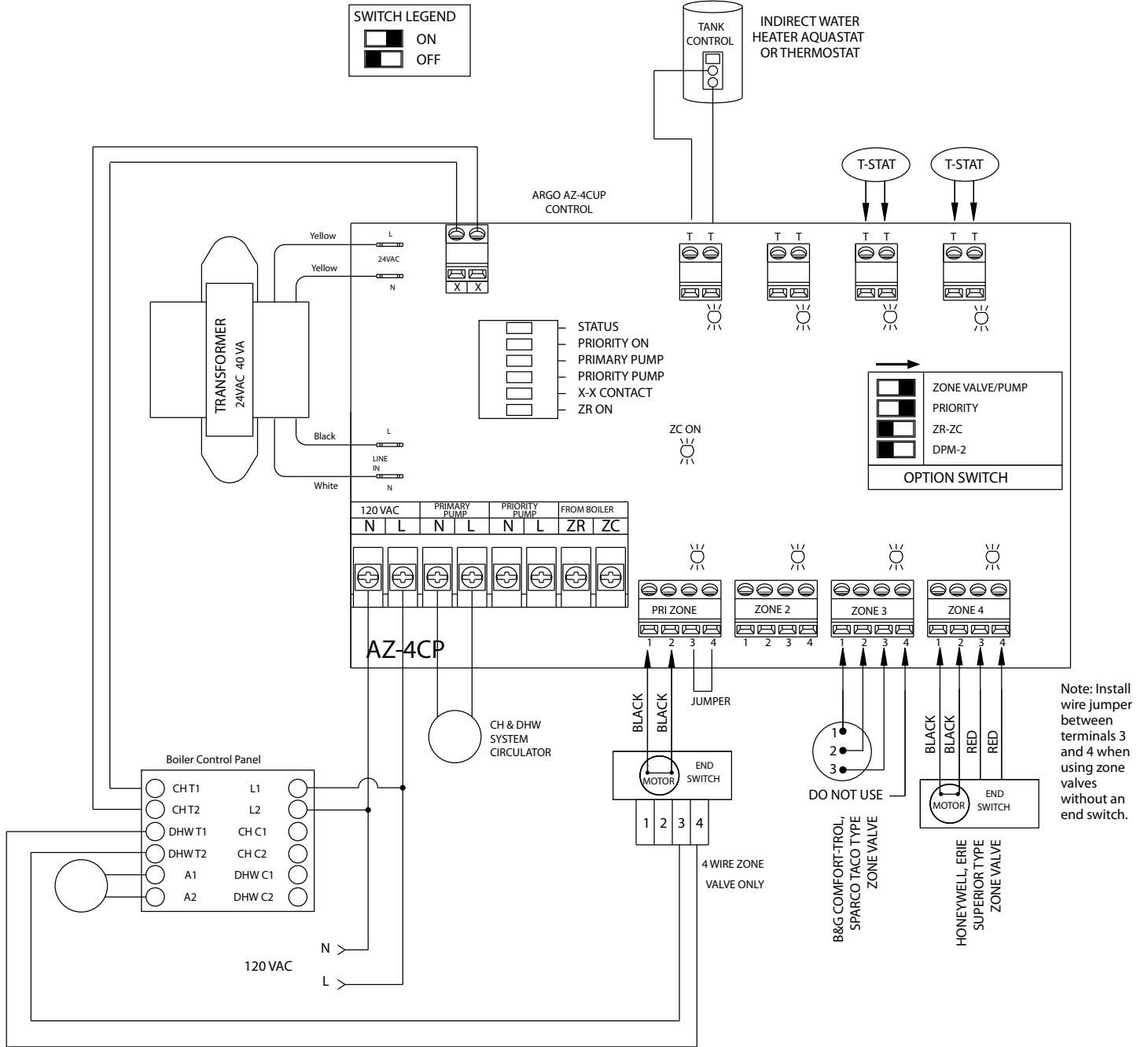

Piping Diagram 3 : Multizone System With Zone Valves And Domestic Hot Water Priority (With Circulator)

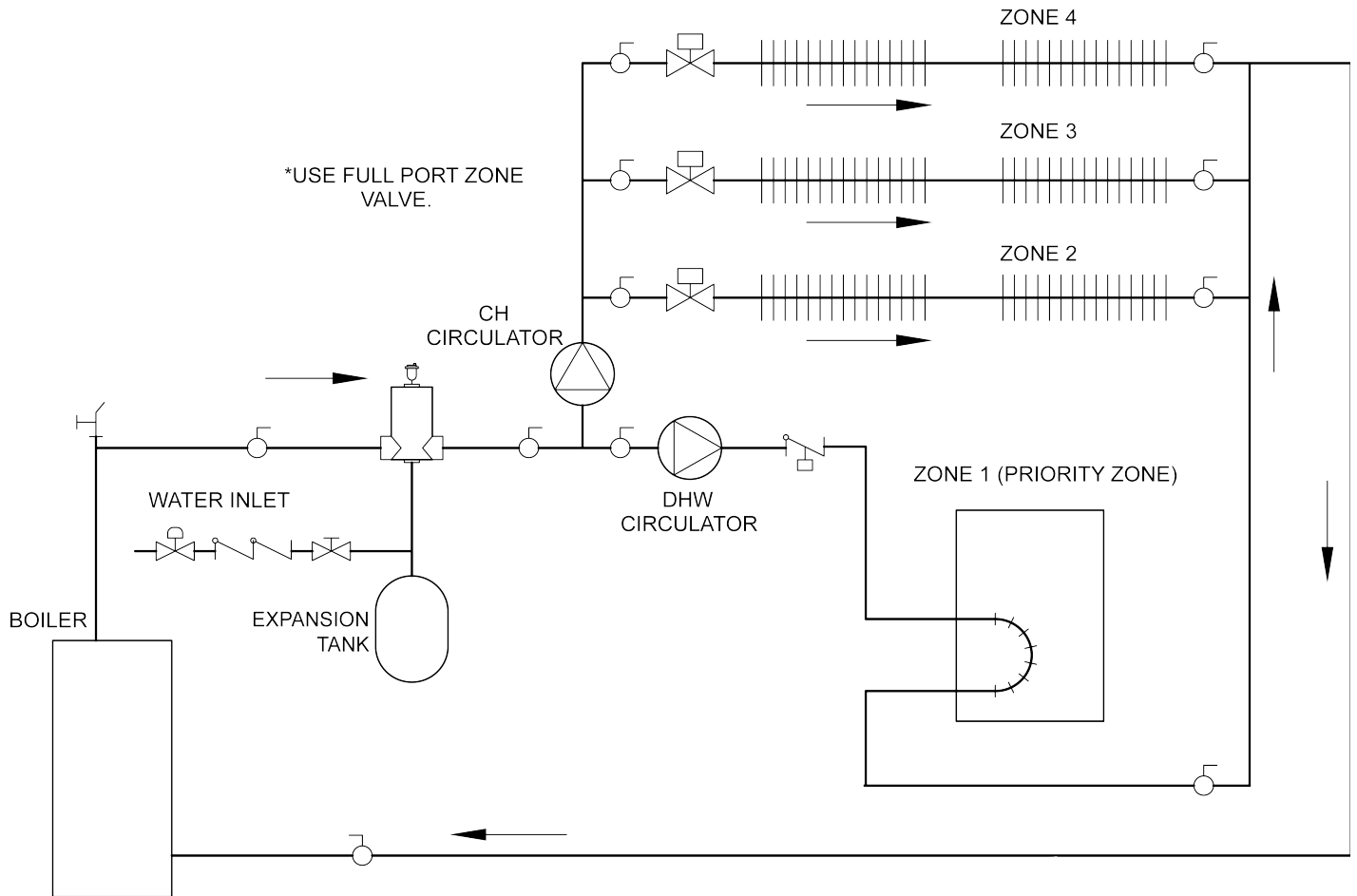

NOTE: NOT RECOMMENDED FOR ANTIFREEZE APPLICATIONS

APPENDIX A - BOILER PIPING AND WIRING

Wiring Diagram 3: Multizone System With Zone Valves And Domestic Hot Water Priority (With Circulator)

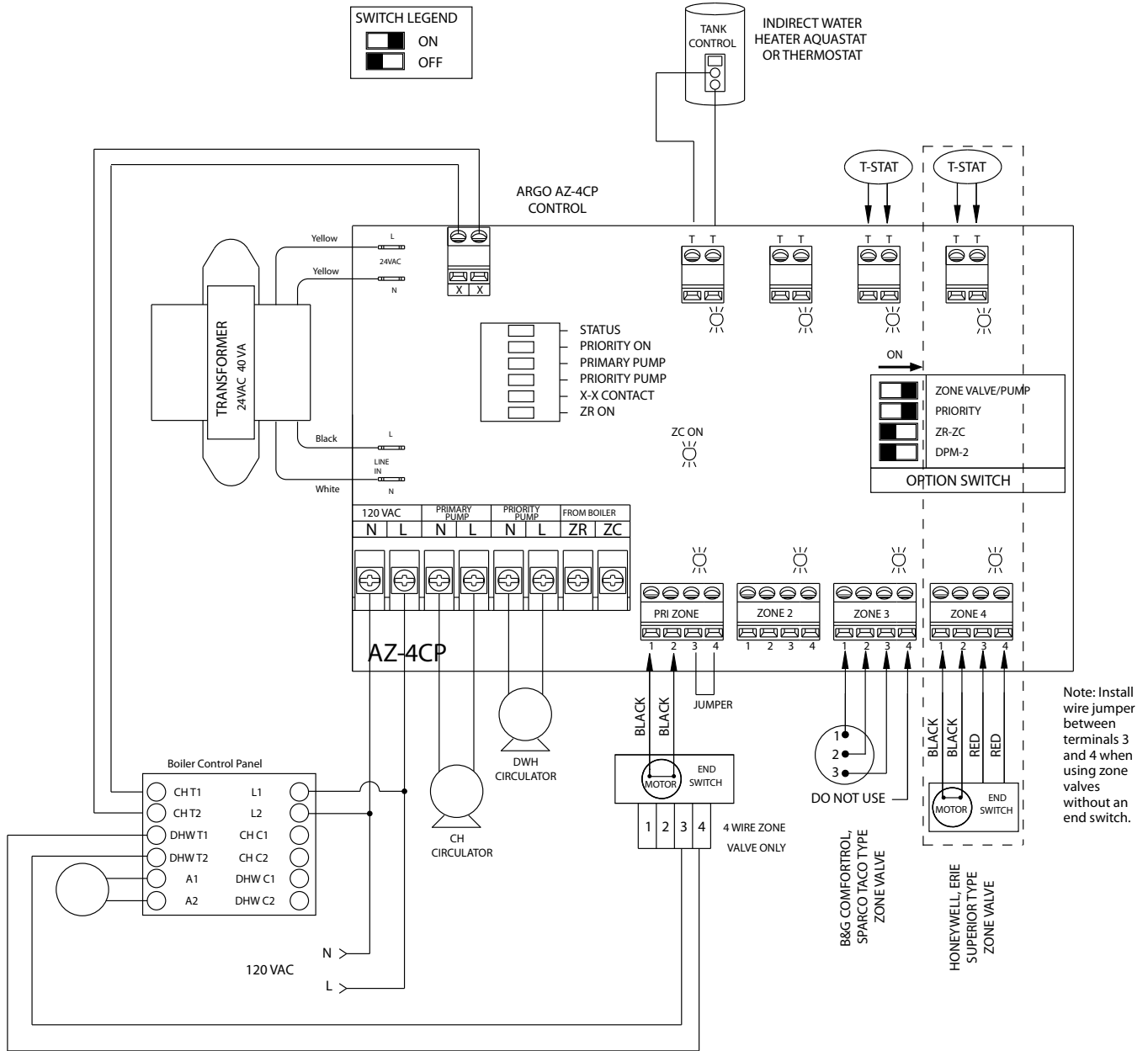

APPENDIX A - BOILER PIPING AND WIRING

Wiring Diagram 4: Multizone System With Circulators And Domestic Hot Water Priority

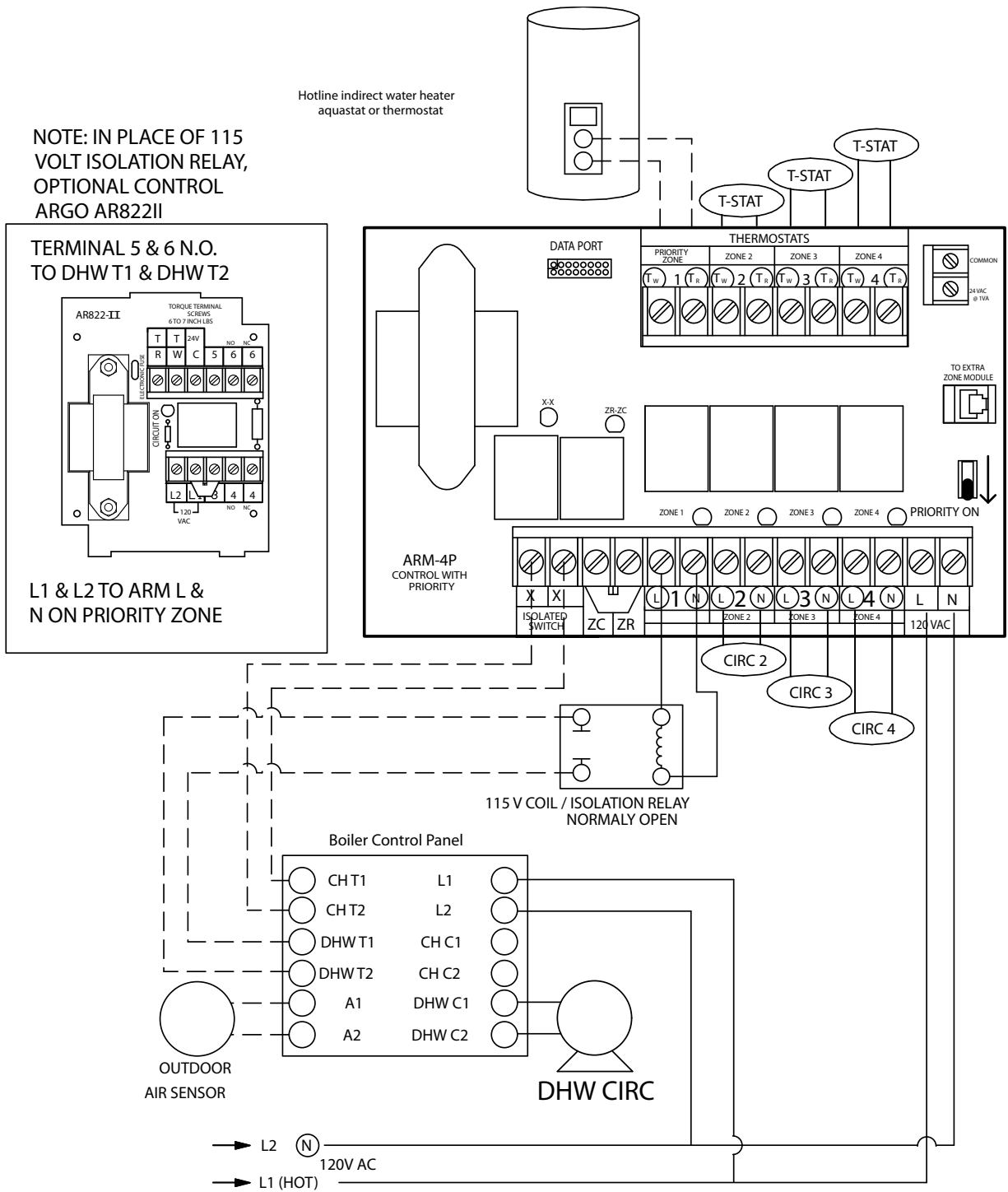

APPENDIX A - BOILER PIPING AND WIRING

Piping Diagram 5 : Primary/Secondary Piping With Circulators And Domestic Hot Water

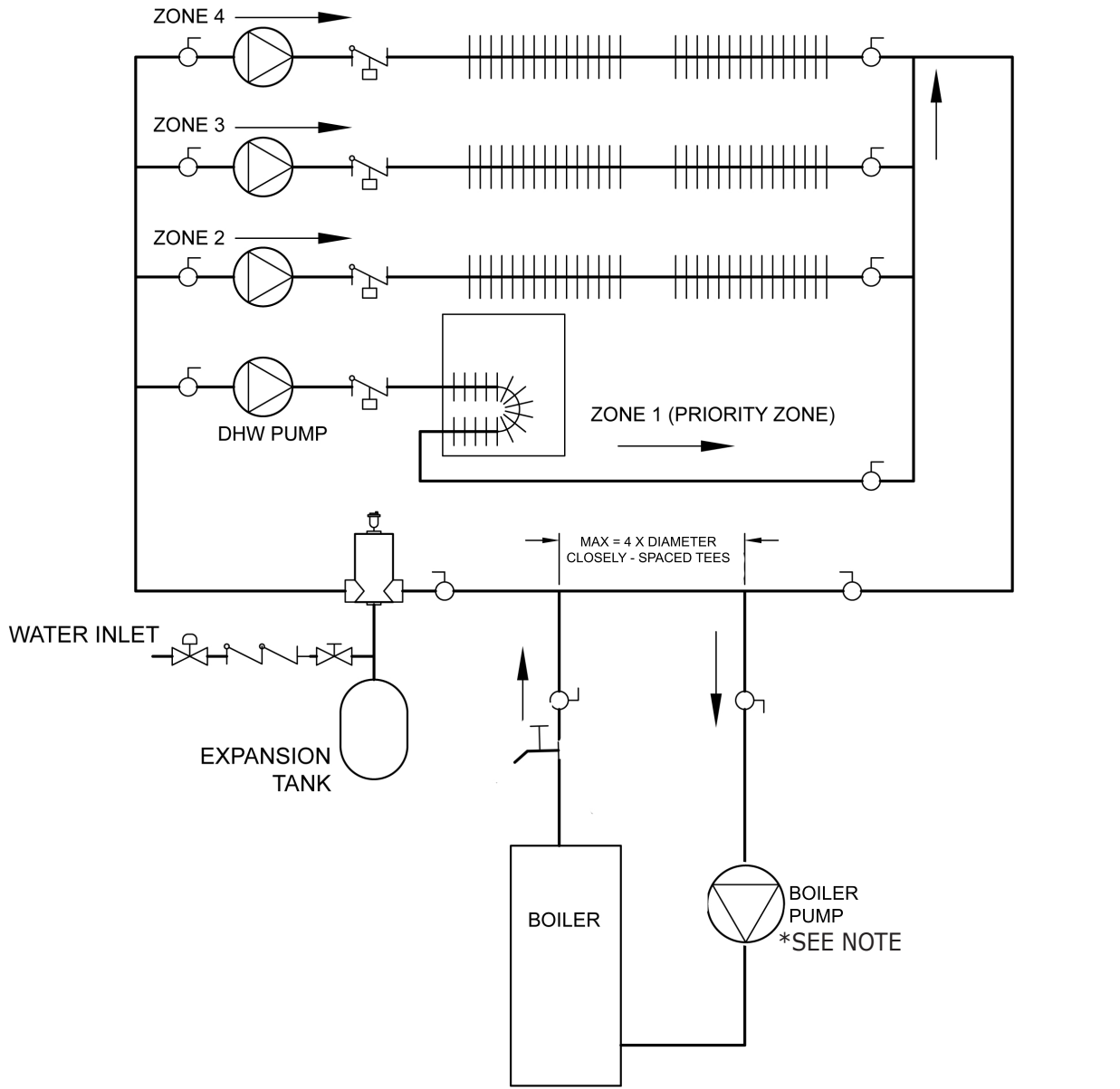

 FLOW CONTROL VALVE

 CIRCULATOR (PUMP)

 SHUT-OFF VALVE

 PRESSURE REDUCER VALVE

 CHECK VALVE

 BALL VALVE

 ZONE VALVE

 AIR SEPARATOR

 HOSE BIB

NOTE: RECOMMENDED FOR ANTIFREEZE APPLICATIONS

APPENDIX A - BOILER PIPING AND WIRING

Wiring Diagram 5 : Primary/Secondary Wiring With Circulators And Domestic Hot Water

NOTE: IN PLACE OF 115 VOLT ISOLATION RELAY, OPTIONAL CONTROL ARGO AR822II

TERMINAL 5 & 6 N.O. TO DHW T1 & DHW T2

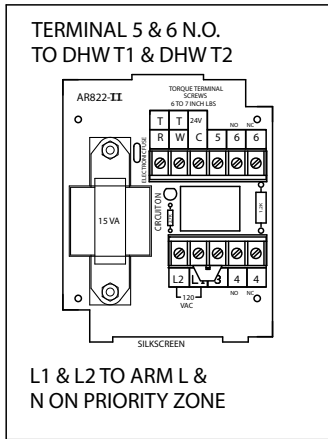

INDIRECT HOT WATER HEATER AQUASTAT OR THERMOSTAT

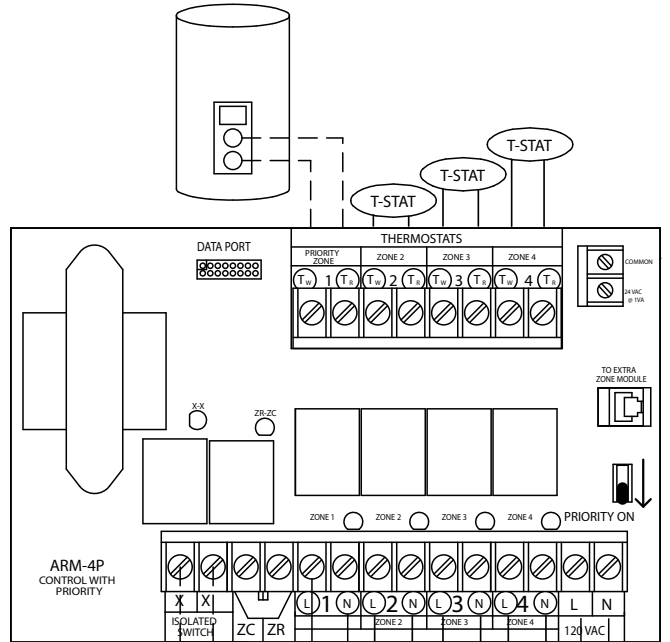

AR822-II

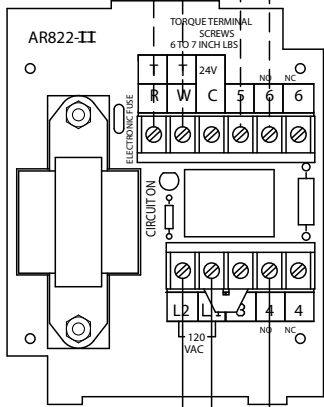

Boiler Control Panel

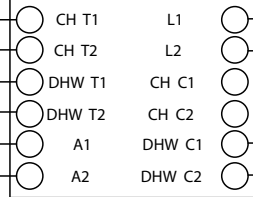

115 V COIL / ISOLATION RELAY NORMALLY OPEN

OUTDOOR AIR SENSOR

DHW CIRC

BOILER CIRC (WILL RUN FOR ALL CH AND DHW CALLS FOR HEAT)

L2 (N) 120V AC

L1 (HOT)

APPENDIX A - BOILER PIPING AND WIRING

Piping Diagram 6 : Primary/Secondary Multizone System Piping With Zone Valves And Domestic Hot Water (With Zone Valve)

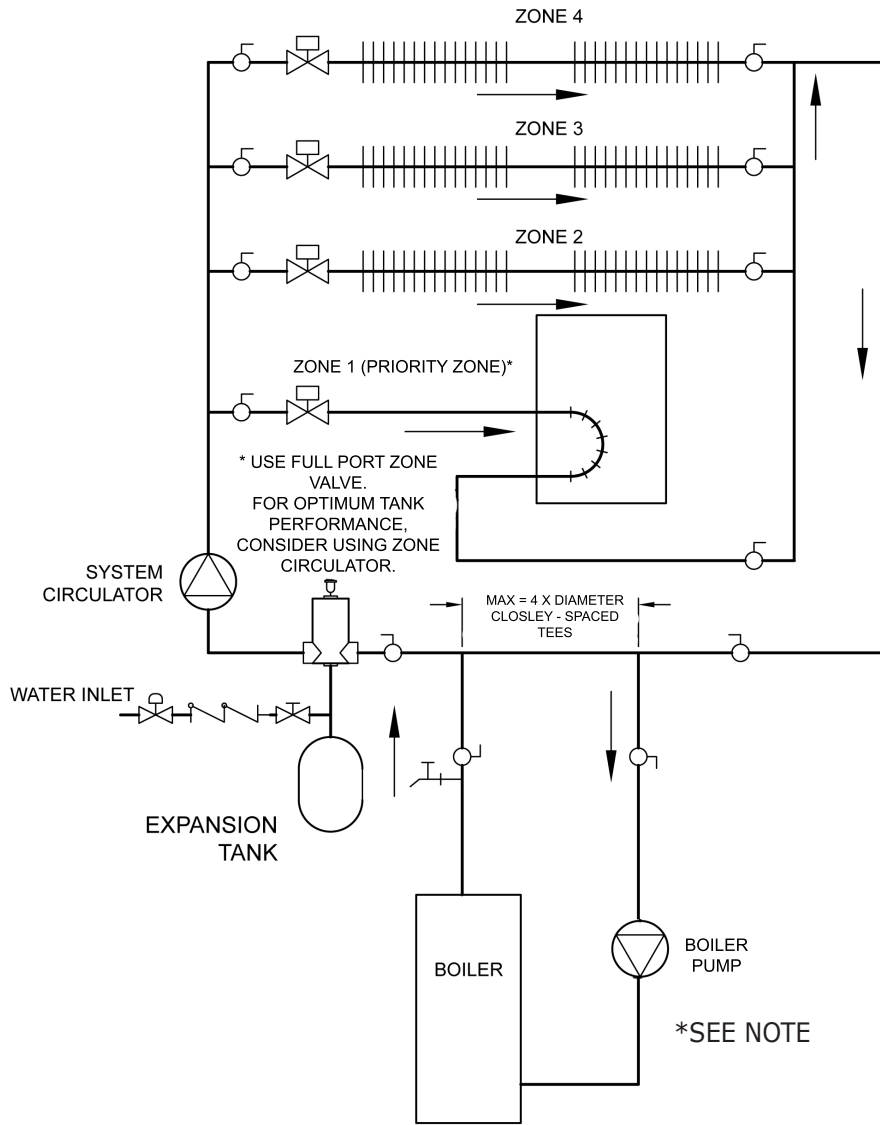

NOTE: RECOMMENDED FOR ANTIFREEZE APPLICATIONS

APPENDIX A - BOILER PIPING AND WIRING

Wiring Diagram 6 : Primary/Secondary Multizone System Wiring With Zone Valves And Domestic Hot Water (With Zone Valve)

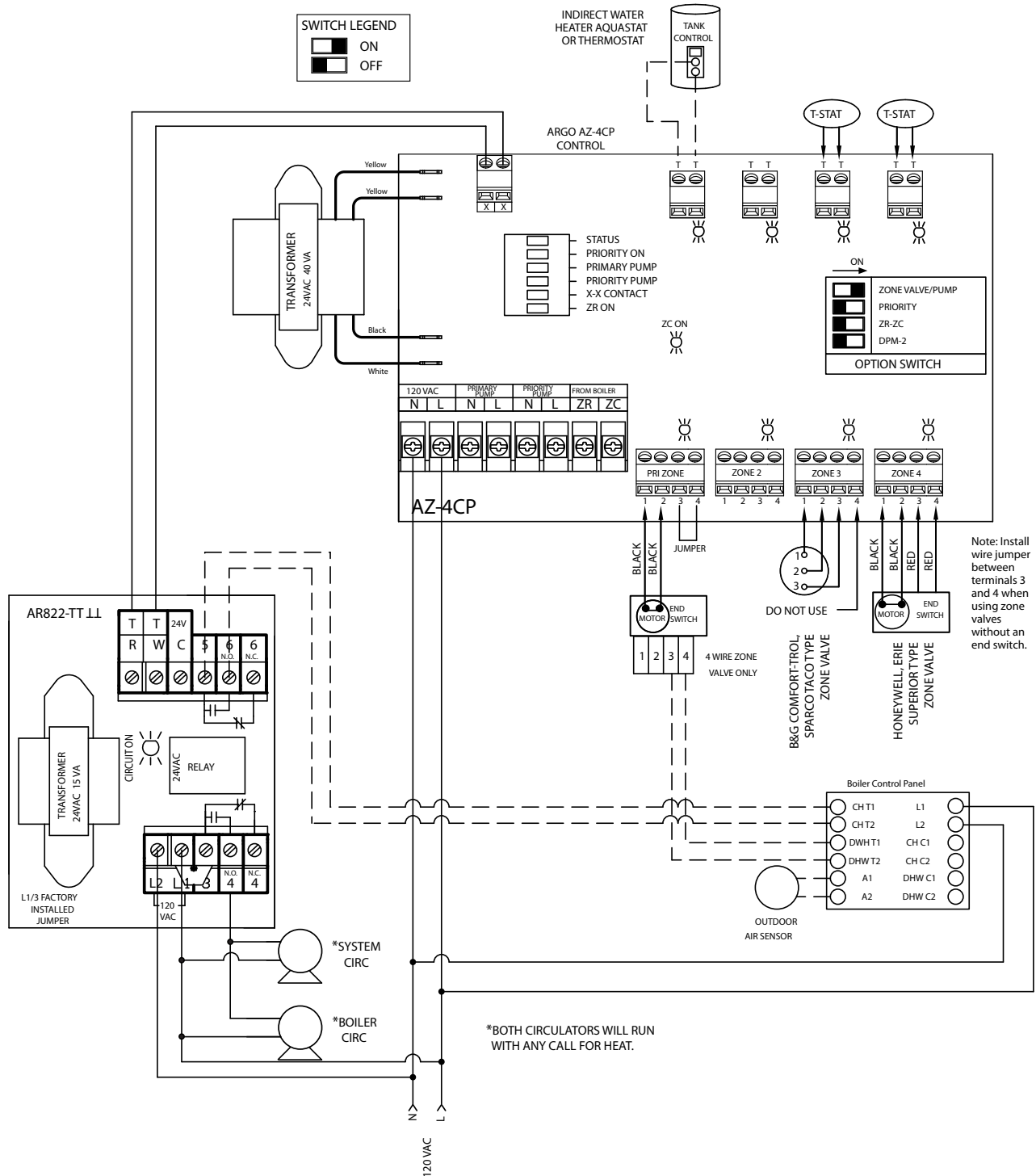

Note: a priority loop zone valve is used with this configuration

APPENDIX A - BOILER PIPING AND WIRING

Piping Diagram 7 : Primary/Secondary Piping With Zone Valves And Domestic Hot Water (With Circulator)

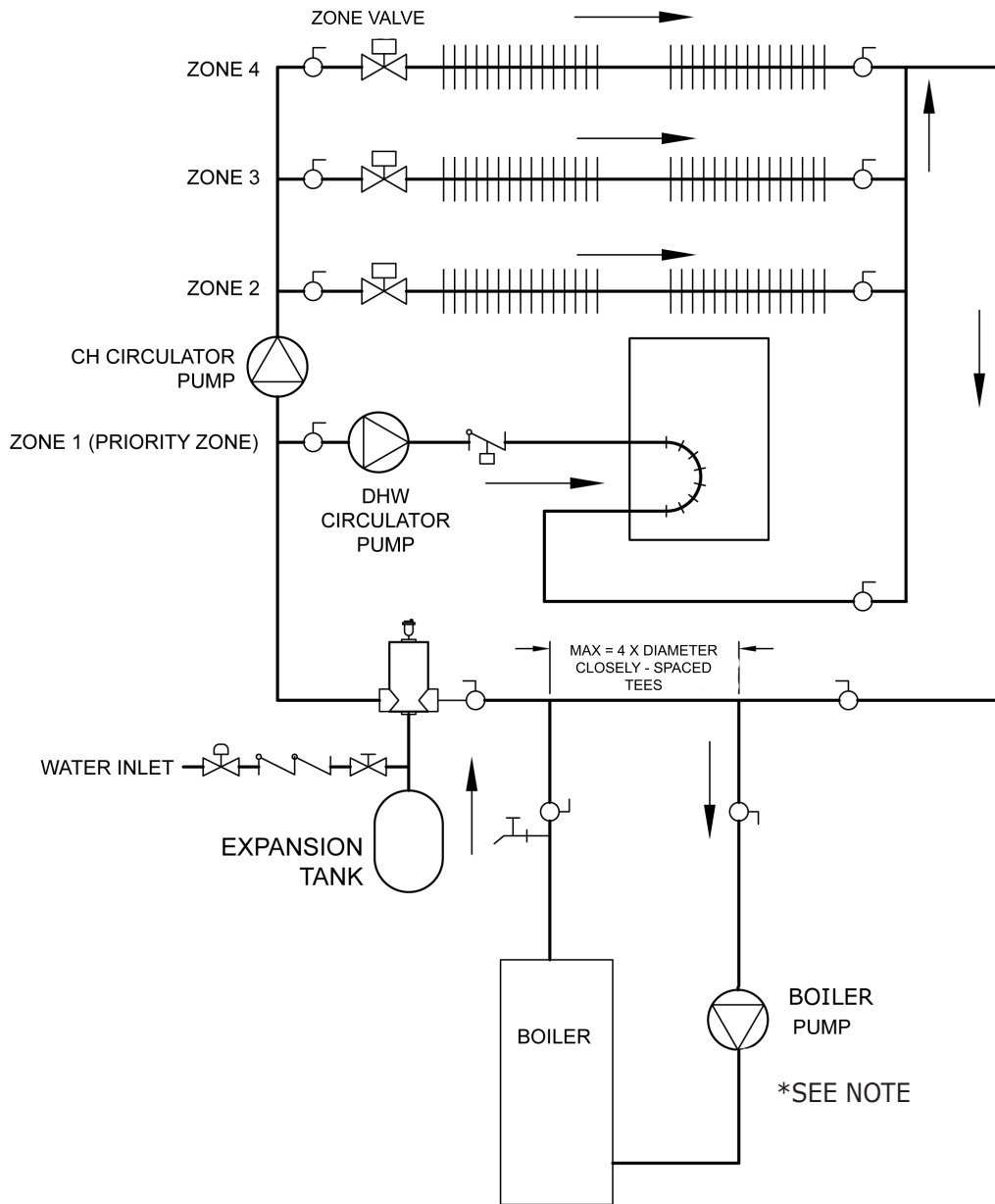

NOTE: RECOMMENDED FOR ANTIFREEZE APPLICATIONS

APPENDIX A - BOILER PIPING AND WIRING

Wiring Diagram 7 : Primary/Secondary Piping With Zone Valves And Domestic Hot Water (With Circulator)

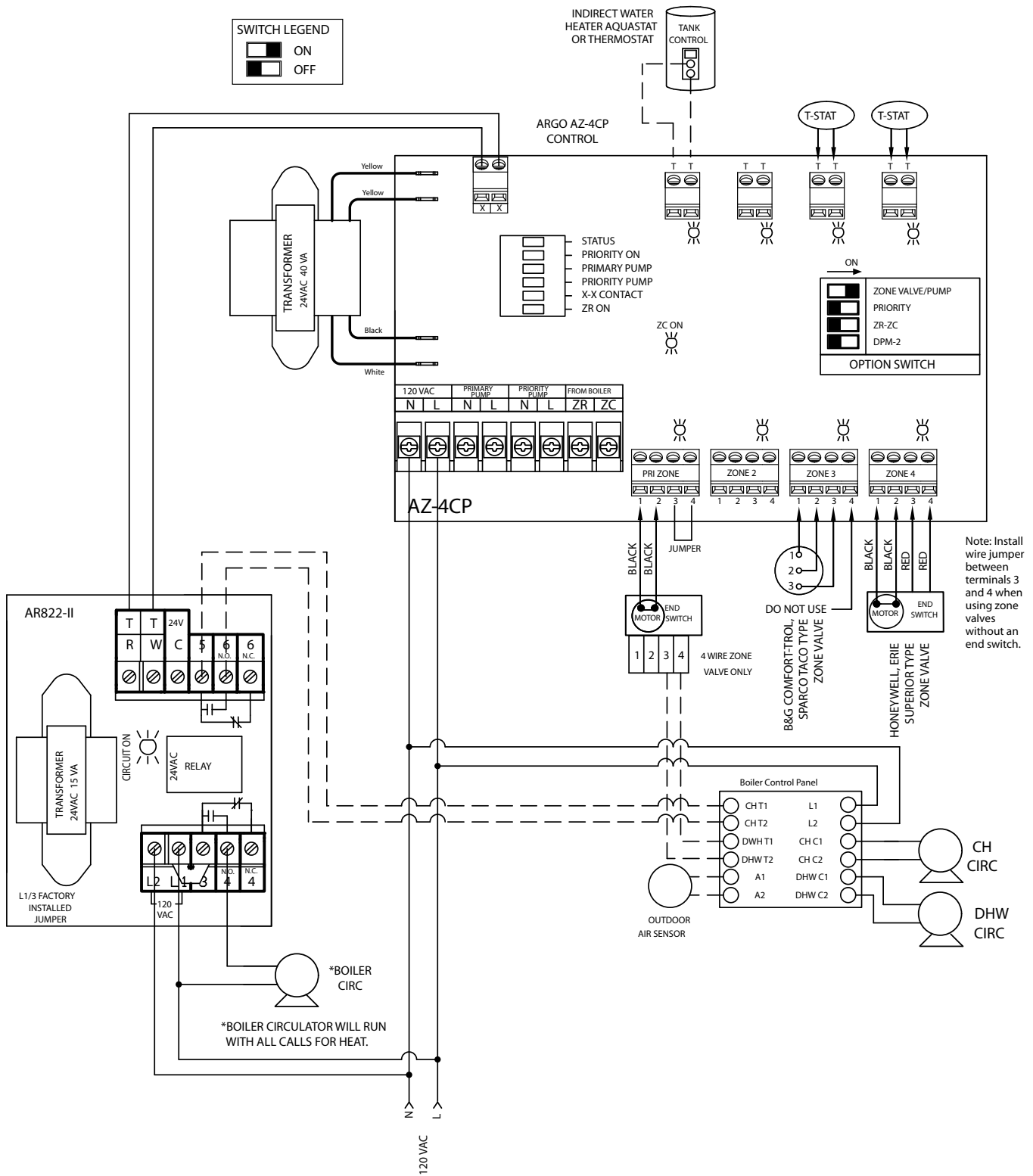

Note: a priority loop zone valve is used with this configuration

Piping Diagram 8 : Bypass Piping (Automatic Mixing Valve)

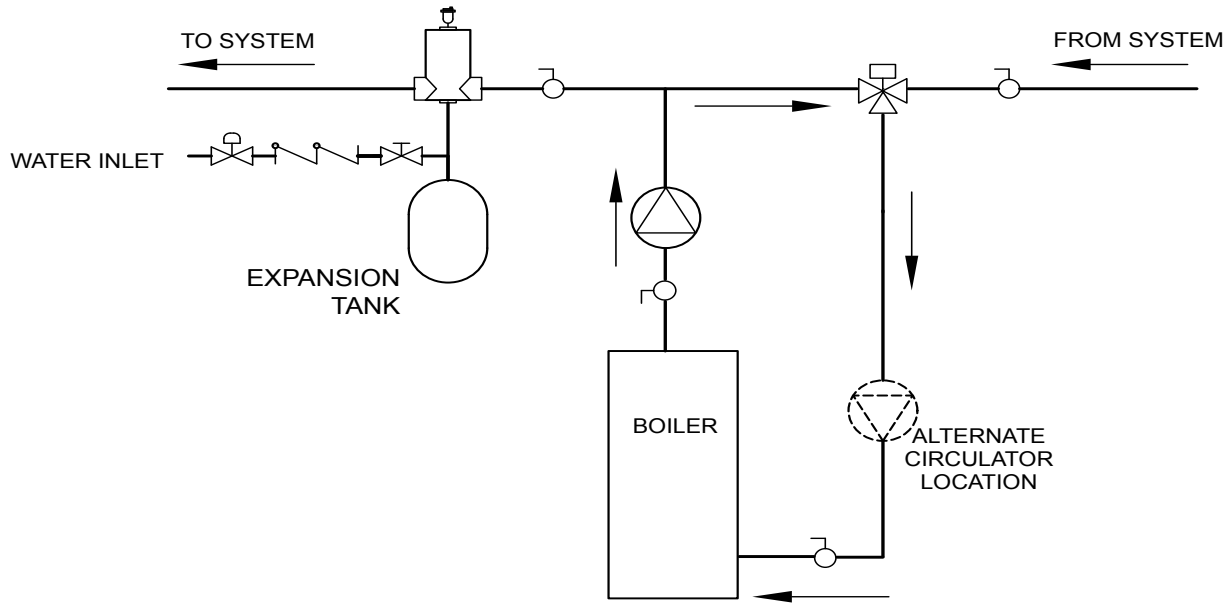

Piping Diagram 9 : Bypass Piping (Fixed Low Temp Only)

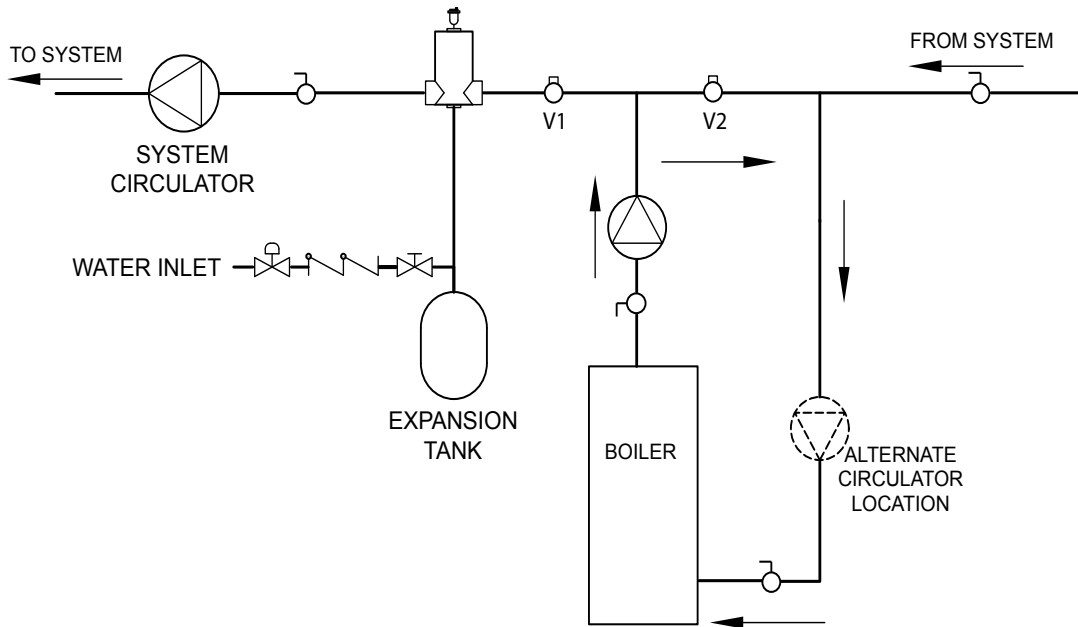

Piping Diagram 10 : Bypass Piping (4-Way Valve Option With Circulator On Supply)

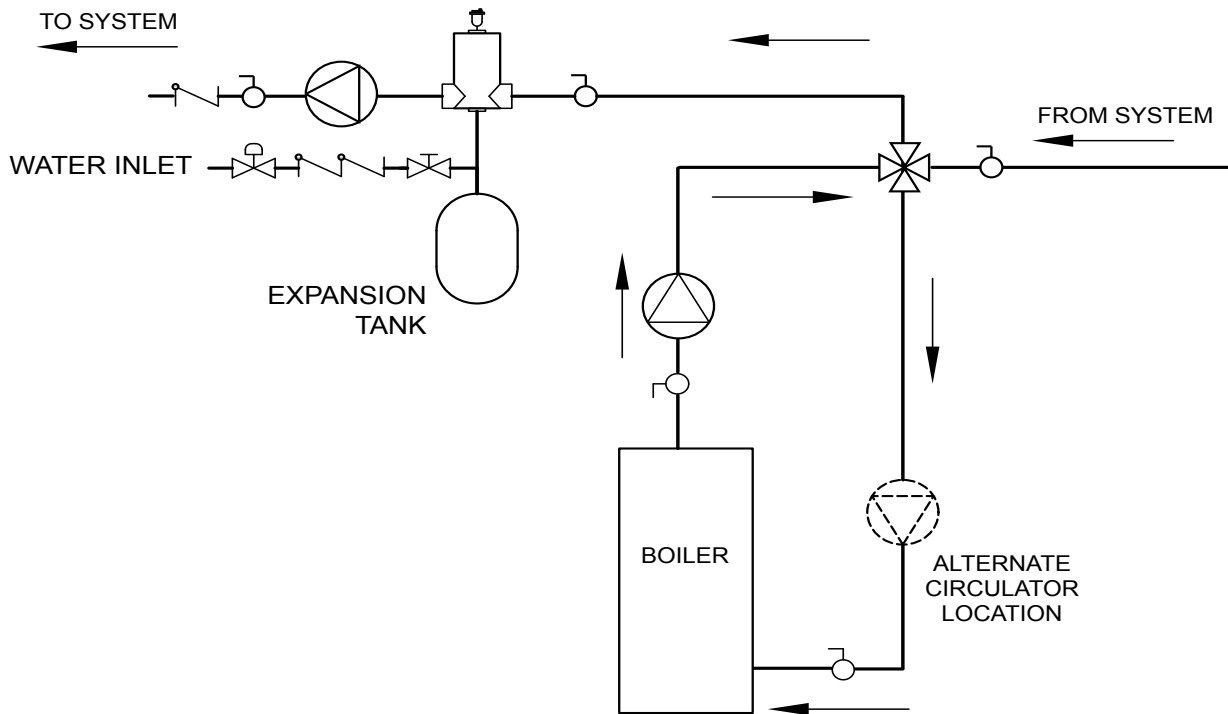

Piping Diagram 11 : Multiple Boiler Piping

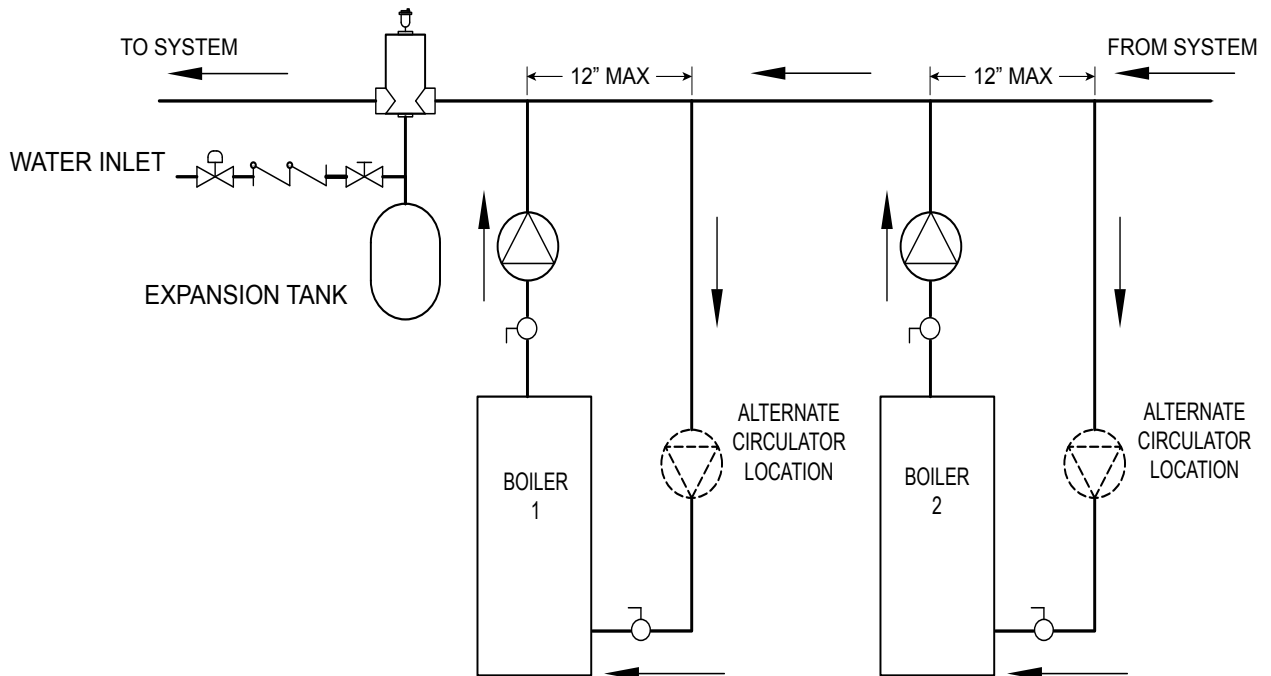

APPENDIX A - BOILER PIPING AND WIRING

Wiring Diagram 9: Multiple Boiler Wiring (AMB-4)

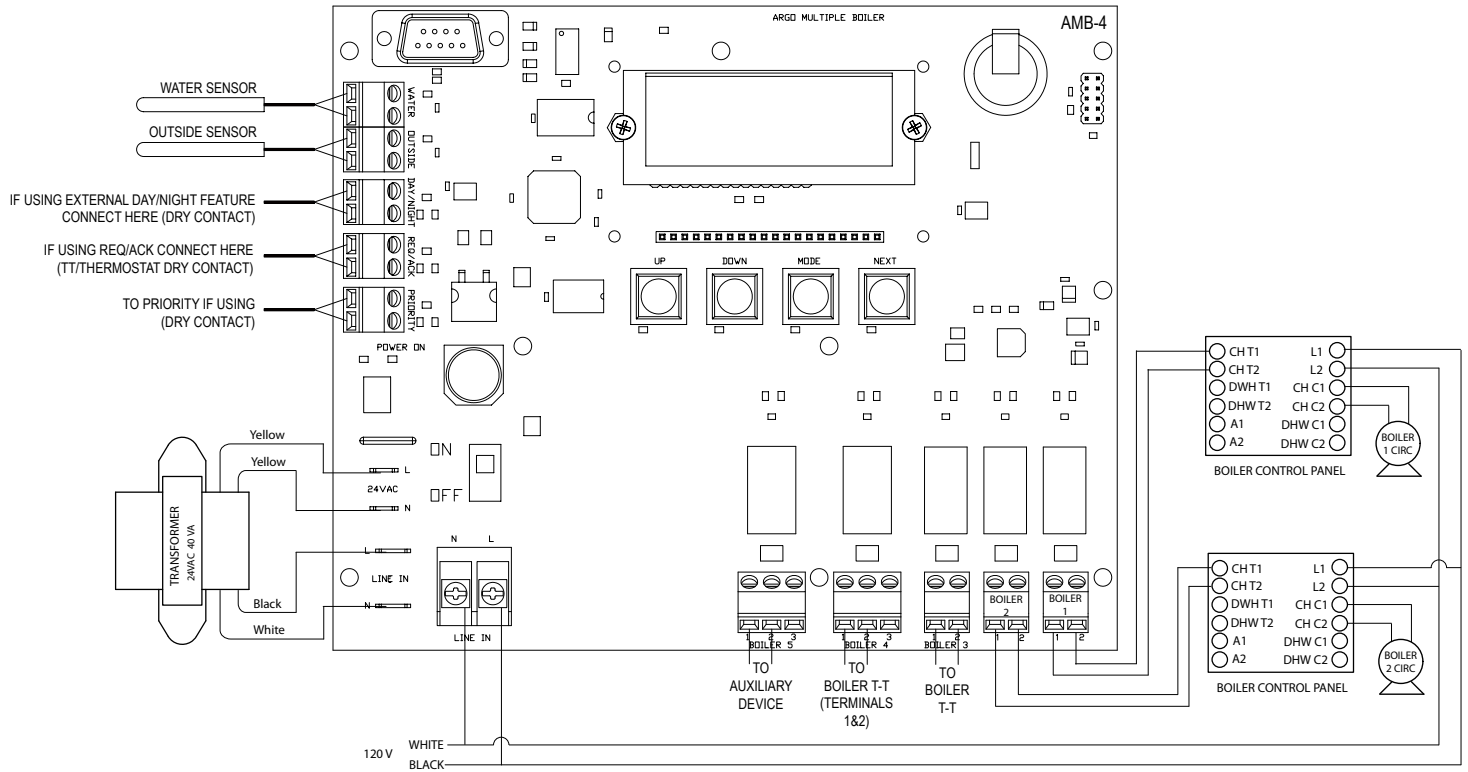

Wiring Diagram 10: Multiple Boiler Wiring (AMB-8)

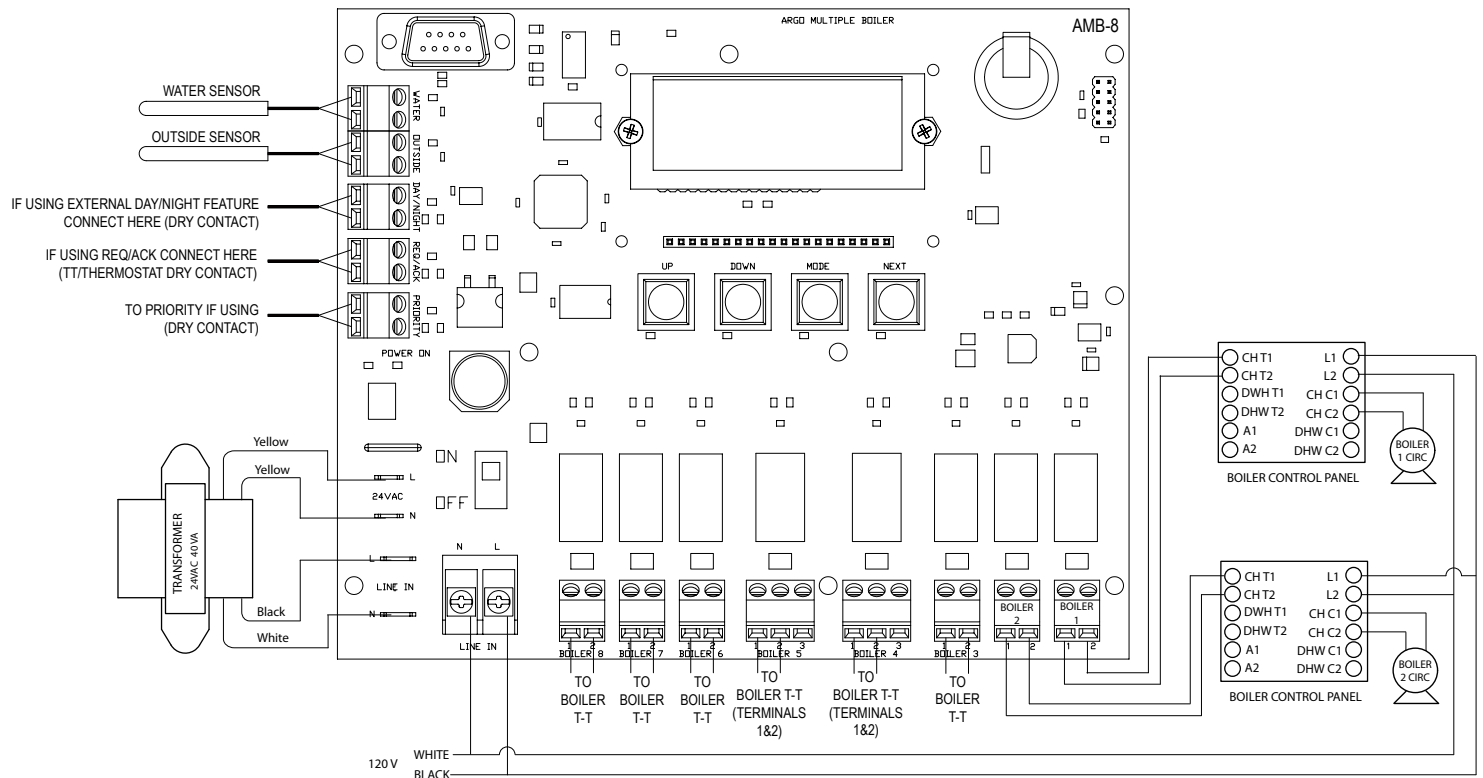

⚠ WARNING

Install boiler so gas ignition system components are protected from water (dripping, spraying, rain, etc) during appliance operation and service (circulator replacement, etc).

• **DIELECTRIC ISOLATION**

Two (2) 1-1/4" X 1-1/4" Female to female dielectric isolation unions are shipped loose in boiler parts bag. Install Dielectric Isolation unions at boiler supply line and return line. Install isolation fittings nearest boiler prior to system piping connections.

• **WATER TREATMENT and ANTIFREEZE PROTECTION**

MUST be applied for ALL aluminum series high efficiency gas-fired boilers using antifreeze protection.

APPENDIX B - WATER QUALITY, WATER TREATMENT AND FREEZE PROTECTION

System and Operating Precautions

Applies to ALL Aluminum High Efficiency Gas-Fired Water Boilers

Clean System First

BEFORE connecting boiler to heating system, clean and flush system thoroughly. Verify system is free of sediment, flux and any residual boiler water additives.

Systems having not recommended antifreeze must be completely flushed to ensure no old antifreeze remains. In older systems obviously discolored, murky or dirty water; or pH reading outside acceptable range (between 7.0 and 8.0) are indications system should be cleaned or treated. Thoroughly flush system with clean water to remove any sediment or contaminants. Sludge and iron oxide deposits can cause rapid breakdown of inhibitors.

Flushing with clean water. If chemical cleaners are used, use only those recommended for use with aluminum boilers. Follow chemical cleaner manufacturer's instructions completely.

DO NOT mix different manufacturer's products.

Fill Water and Chemistry

Verify water used to fill system meets these requirements:
System fluid pH maintained between 7.0 and 8.0.

Maintain water hardness below 7 grains hardness.

Filling with chlorinated potable water is acceptable. DO NOT fill boiler with water containing chlorine in excess of 100 ppm.

DO NOT use inhibitors or other additives that are not listed at end in this addendum.

Consult local water treatment specialist for recommendations if any of above requirements is outside stated ranges.

Eliminate System Leaks

Continuous addition of make-up water will constantly add oxygen to system. Eliminate all system leaks. All system leaks must be repaired immediately.

Verify expansion tank is operational and properly sized. Undersized expansion tanks cause relief valve weeping and substantial make-up water addition.

Operation of this boiler in system containing significant amounts of dissolved oxygen can cause severe heat exchanger corrosion damage.

This boiler is not designed for use in systems containing regular additions of make-up water. Regular additions of make-up water may cause severe heat exchanger damage. System leaks may not always be visible. Unseen system leak will become obvious if boiler pressure decreases when make-up valve is closed.

This boiler is designed for closed loop hydronic heat system **ONLY!** This boiler is not suitable for natural gravity type installations, or any other open type system.

APPENDIX B - WATER QUALITY, WATER TREATMENT AND FREEZE PROTECTION

System and Operating Precautions

Applies to ALL Aluminum High Efficiency Gas-Fired Water Boilers

General Guidelines When Using Antifreeze

- **Use only antifreeze products recommended for use with aluminum boilers, as listed in this addendum. See Table 1, page 48.**
- Continuous addition of make-up water will dilute power of antifreeze and change buffers ability to maintain pH.
- Flush old antifreeze from system. Flush boiler and system separately.
- Do not use antifreeze unless required.
- Antifreeze, if needed, must be of type listed on next page due to their operational characteristics of : type 356 T6 aluminum at operating temperatures between 20°F (-6.7°C) and 250°F (121°C). (See Table 1 for allowable products.)
- Always clean system prior to using antifreeze as stated in this supplement.
- Be sure to follow antifreeze manufacturer's instructions for use, safe handling and storage of their products. Refer to MSDS (Material Safety Data Sheets) provided by antifreeze manufacturer for potential hazards and first aid procedures for exposure or ingestion.
- Antifreeze will raise pH of hydronic solution in heating system above recommended level due to corrosion inhibitors. Solution must be treated to maintain a pH within recommended level. Follow antifreeze manufacturer's instructions to adjust pH.
- If system has leaked, water and antifreeze chemistry will need to be adjusted. To avoid damage to boiler, check pH and chemistry of boiler solution and consult the antifreeze manufacturer for recommendations.
- It is recommended that pH reading be taken annually, and adjusted as necessary. Follow antifreeze/inhibitor manufacturer's instructions for details on how to adjust pH.
- Antifreeze solutions can break down over time. Failure to check antifreeze chemistry on annual basis may result in accelerated corrosion of boiler and other system components. Consult with antifreeze manufacturer for recommendations.
- Use of antifreeze in any boiler will reduce heating capacity as much as 10-20%. Take into consideration when sizing heating system, pumps and expansion tank. Consult antifreeze manufacturer's literature for specific information on reduced capacity.
- Using antifreeze manufacturer's instructions, determine freezing temperature needed and use correct amount of antifreeze. Never exceed 50% antifreeze by volume.
- Boiler operating pressure must remain below 15 psi for antifreeze solutions that specify a maximum of 250°F (121°C). Otherwise, increase system operating/tank pressure to 20 psig. **Note: Refer to expansion tank manufacturer instructions for adjusting tank pressure.**

APPENDIX B - WATER QUALITY, WATER TREATMENT AND FREEZE PROTECTION

System and Operating Precautions

Applies to ALL Aluminum High Efficiency Gas-Fired Water Boilers

Table 1 Antifreeze Products

Compatible Aluminum Antifreeze & Inhibitor Suppliers	
Noburst AL Antifreeze	Noble Company P. O. Box 350 Grand Haven, MI 49417 www.noblecompany.com Tel: 800-878-5788 Fax: 231-799-8850
Rhogard Antifreeze & Pro-Tek 922 Inhibitor*	Rhomar Water Management, Inc. P. O. Box 229 Springfield, MO 65801 www.rhomarwater.com Tel: 800-543-5975 Fax: 417-862-6410
* Pro-Tek 922 Inhibitor may be used to adjust the pH level of the hydronic system, but on occasion may not resolve the pH issue. In these cases, flush the system and refill with untreated water and antifreeze suitable for aluminum heat exchangers, as listed in this supplement.	
Alphi-11	Hydronic Agencies, Ltd. (Fernox North Distributor) 15363 117 Avenue Edmonton, AB T5M 3X4 Canada www.hydronicagencies.com Tel: 780-452-8661 Fax: 780-488-2304 Fernox www.fernox.com
Intercool NFP-30,40,50 AA Intercool RPH-15*	Interstate Chemical 2797 Freedland Road P.O. Box 1600 Hermitage, PA 16148-0600 www.interstatechemical.com Tel: 800-422-2436 Fax: 724-981-8383
Hercules cryo-tek™-100/AI	Hercules Chemical Company, Inc. 111 South Street Passaic, NJ 07055 www.herchem.com Tel: 800-221-9330 Fax: 800-333-3456
* This product may be used to adjust pH level of hydronic system, but on occasion may not resolve pH issue. In these cases it is recommended to flush system and refill with untreated water and new boiler manufacturer approved antifreeze suitable for Aluminum heat exchangers.	

SERVICE RECORD

Company Address & Phone #																			
Company Name & Tech Initials																			
Service Performed																			
Date																			

IMPORTANT

In accordance with Section 325 (f) (3) of the Energy Policy and Conservation Act, this boiler is equipped with a feature that saves energy by reducing the boiler water temperature as the heating load decreases.

This feature is equipped with an override which is provided primarily to permit the use of an external energy management system that serves the same function.

THIS OVERRIDE MUST NOT BE USED UNLESS AT LEAST ONE OF THE FOLLOWING CONDITIONS IS TRUE:

- An external energy management system is installed that reduces the boiler water temperature as the heating load decreases.
- This boiler is not used for any space heating
- This boiler is part of a modular or multiple boiler system having a total input of 300,000 BTU/hr or greater.
- This boiler is equipped with a tankless coil.