



Models

Q90-125

Q90-150

Q90-175

Q90-200

Q90 125-200 SERIES II
GAS-FIRED DIRECT VENT
CONDENSING HOT WATER BOILER

**REPAIR PARTS,
OPTIONAL KITS**

Ordering Instructions

Order Parts through your nearest supplier.
When ordering parts, obtain Model Number and
Serial Number from data plate on your boiler.
Include following information when ordering.

Part Number _____

Part Description _____

Boiler Model Number _____

Boiler Serial Number _____



ECR international
EST. 1928
A Family of Heating & Cooling Brands.

Manufactured by:
ECR International, Inc.
2201 Dwyer Avenue, Utica NY 13501
web site: www.ecrinternational.com

P/N 240009452, Rev. D [04/2015]

JACKET AND BASE ASSEMBLY

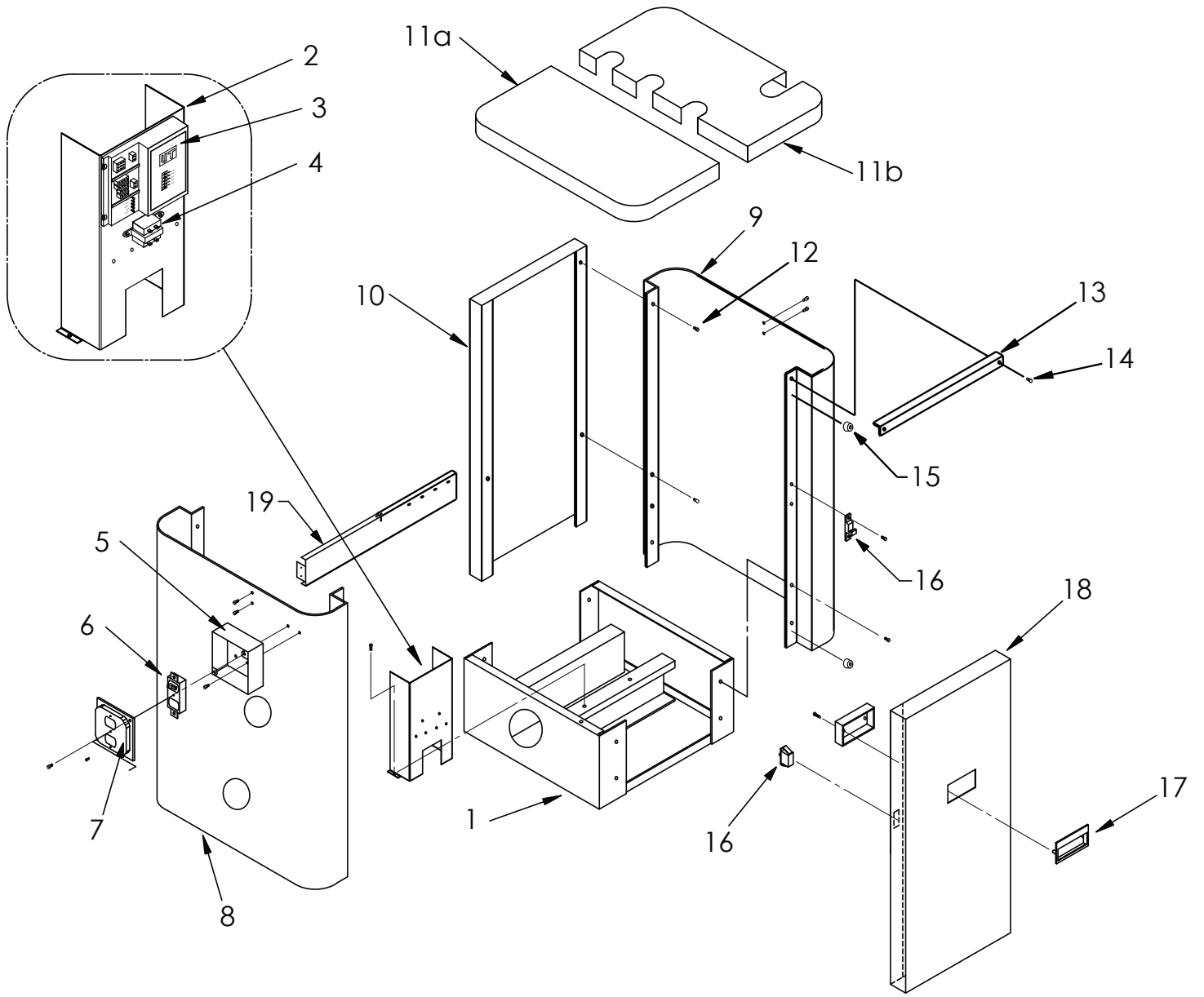

JACKET AND BASE ASSEMBLY

ITEM	PART NO.	DESCRIPTION	QTY.
1	2272144	Base Replacement Kit (125-200)	1
2	650001028	Control Panel	1
3	14662803	Control Integrated	1
4	550001339	40 VA Transformer Replacement Kit	1
5	14631316	4" x 4" x 2 1/8" J-Box	1
6	14631319	Switch, P & S	1
7	14631318	J-Box Plate Cover	1
8	2272152AC	Jacket Panel, Left Side Replacement Kit, Blue	1
9	2272151AC	Jacket Panel, Right Side Replacement Kit, Blue	1
10	750001031AC	Jacket Panel, Back, Blue	1
11a	2370003AC	Jacket Panel, Top Left, Blue	1
11b	2370004AC	Jacket Panel, Top Right, Blue	1
12	14695074	Screw #10 x 1/2" ZP	14
13	750001034	Jacket Tie Bar	1
14	14695060	Screw #10 x 1/2"	12
15	1225013	Tap Bumper	4
16	1225012	Latch and Clip Kit	1
17	14631095	Door Pull	1
18	2272150AC	Jacket Service Door Replacement Kit	1
19	2485001	Pressure Switch Mounting Plate	1
*	240006970	Wire Harness	1
*	14631174	2 1/2" Plug	1
*	2272164	Jacket, Complete Replacement Kit, Blue	1

* Not Shown

CIRCULATOR PUMPS (OPTIONAL)

PART NO.	DESCRIPTION	QTY.
CI-001.01	Circulator Pump w/Flange, B&G	1 ^(a)
CI-001.03	Circulator Pump w/Flange, Taco	
CI-006.01	Circulator Pump w/Flange, Grundfos	

^(a) Please specify pump when ordering. Consult factory for details.

^(b) Not available on all models. Consult factory for details.

BURNER ASSEMBLY

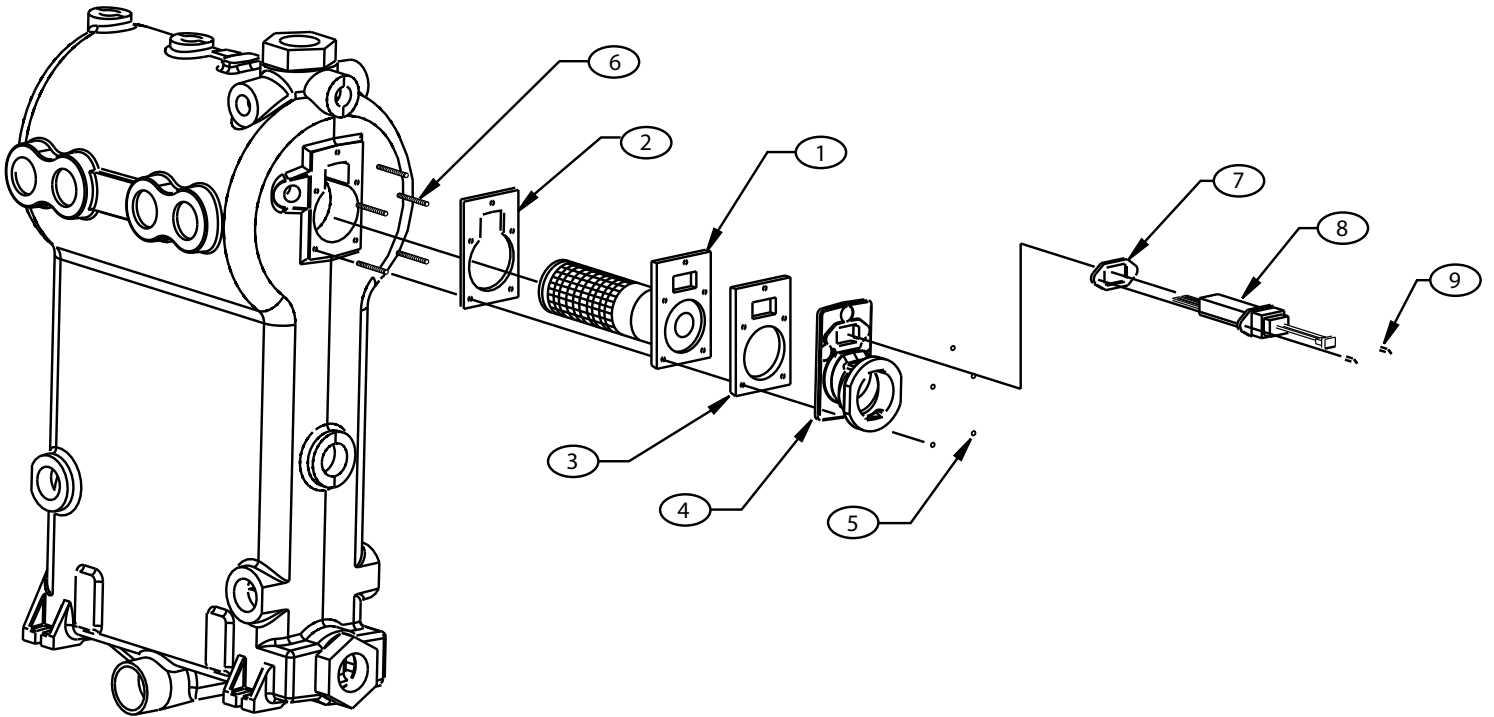

ITEM	PART NO.	DESCRIPTION	QTY.
1	2272149	Burner Replacement Kit	1
2	1250009	Burner/Casting Gasket	1
3	1250008	Burner/Flue Adapter Gasket	1
4	12101022	Flue Adapter	1
5	14695810	Hex Nut w/Serrated Washer ¼"-20	5
6	1450011	Threaded Stud ¼"-20 x 1½"	5

Hot Surface Igniter Replacement Kit (P/N#[550002068](#))

(includes Items 7-9 (below))

7	—	Igniter/Mixer Gasket	1
8	—	Hot Surface Igniter	1
9	—	Screw 10-32 x ¾"	2

BOILER BLOCK AND PIPING ASSEMBLY

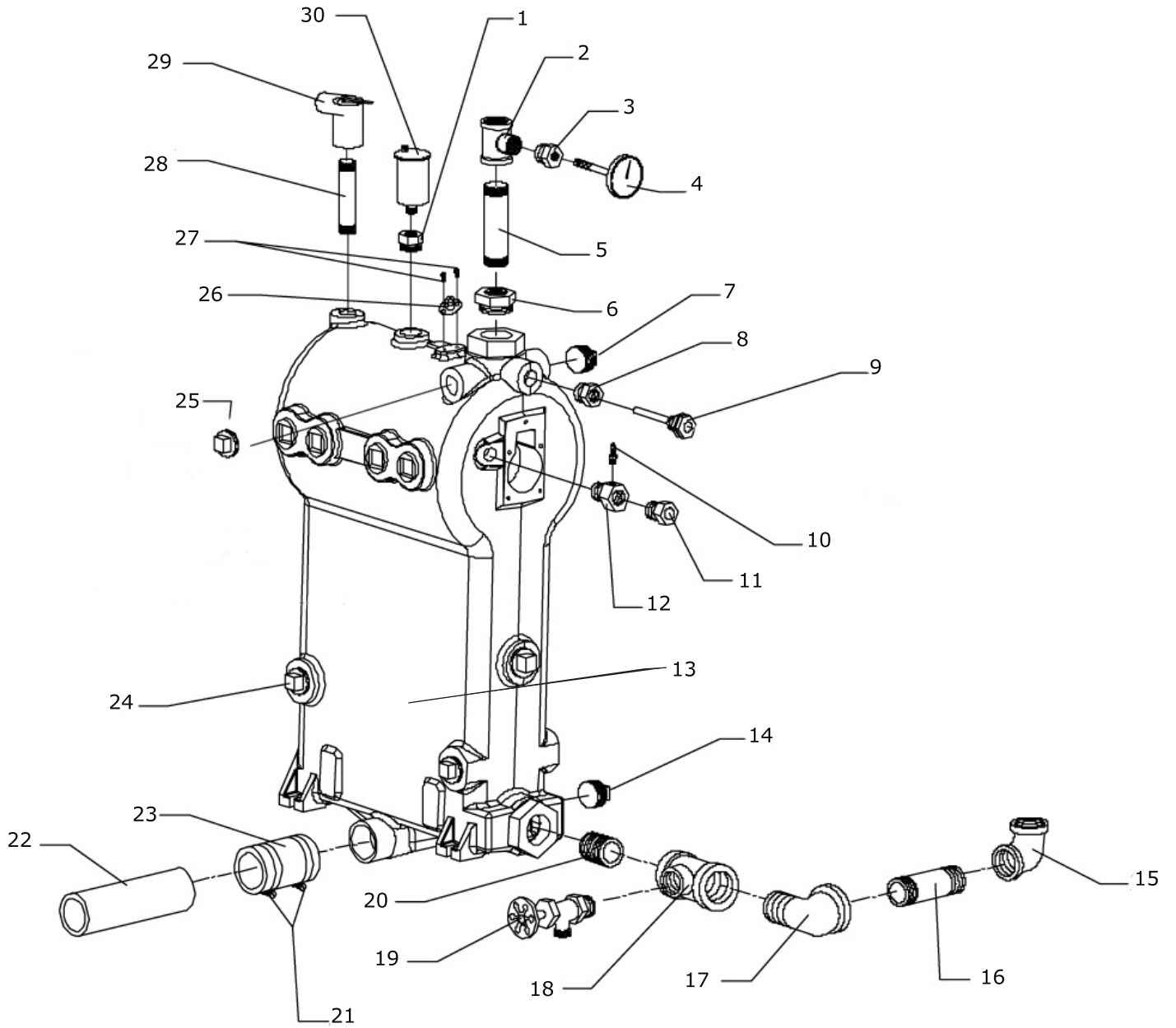

BOILER BLOCK AND PIPING ASSEMBLY

ITEM	PART NO.	DESCRIPTION	QTY.	
	2272160	Block Replacement Kit (Includes the following)	1	
1	240006955	Bushing, 3/4" x 1/8" Forged Steel	1	
6	240006459	Bushing, 1 1/2" x 1/4" 3000# Forged Steel	1	
7	240006957	Plug, 1" Forged Steel	2	
8	240006952	Bushing, 3/4" x 1/2" Forged Steel	1	
9	240009413	Well, Control 1/2" Hydrolevel	1	
10	1230010	Barb fitting, 1/8" x 3/16"	1	
11	14619002	Observation glass 3/4"	1	
12	14631004	Adapter	1	
13	240007283	Aluminum Monoblock Machined	1	
20	240006951	Pipe nipple, 1 1/2" x close Forged Steel	1	
26	1500005	Casting temp safety switch	1	
*	1450011	Threaded Stud 1/4-20 x 1 1/2	5	
*	14695810	Nut, 1/4-20 HWS	5	
*	240006460	Sealant, Anaerobic, 250 ML tube	1	
*	1040004	Bolt, 5/16 x 1 1/2 Carriage	4	
*	1330001	Nut, 5/16-18 Whizlok,	4	
*	14695004	Self Tapping Screw 8-32 x 3/8	2	
The following parts are not included in the block replacement kit				
2	PF05901	1 1/4" x 1 1/4" x 3/4" Std. Black Tee	1	
3	1060002	3/4" x 1/4" Std. Black Iron Bushing	1	
4	1260006SP	Temp/Pressure Gauge, 2" Shank	1	
5	PF06501	1 1/4" x 7" NPT Std. Black Pipe Nipple	1	
14	240006957	Plug, 1" Forged Steel	2	
15	1190002	Elbow 1 1/4" x 90°	1	
16	1310002	Nipple, Std. Blk. 1 1/4" x 4 1/2"	1	
17	1190004	1 1/4" Street Elbow Blk. 90°	1	
18	1510010	Reducing Tee 1 1/2" x 1 1/4" x 3/4"	1	
19	240009323	Valve BLR DR 3/4"	1	
21	14631302	Clamp stainless steel #44	2	
22	240006827	Vent Pipe 2" CPVC SCH-40 x 7" S636	1	
23	14631301	Hose 3" Long x 2 3/8" ID x 2 3/4" OD	1	
24	1395002	1 1/4" Socket Head Plug	16	
27	14695802	Screw Soc HD Cap 8-32 x 3/16"	2	
28	14607002	3/4" x 6 1/2" Std. Black Nipple	1	
29	14622011	3/4" Relief Valve	1	
30	1580006	Air Purge Vent w/Check Valve	1	
*	240009365	High Limit, LWCO Control	1	
	550002586	Kit, replacement LWCO / High Limit Control	1	
*	550002586 LWCO Replacement Kit	240009365	LWCO, High Limit	1
		240009413	Well, High Limit	1
* Not Shown				

EXHAUST TEE AND CONDENSATE TRAP ASSEMBLY

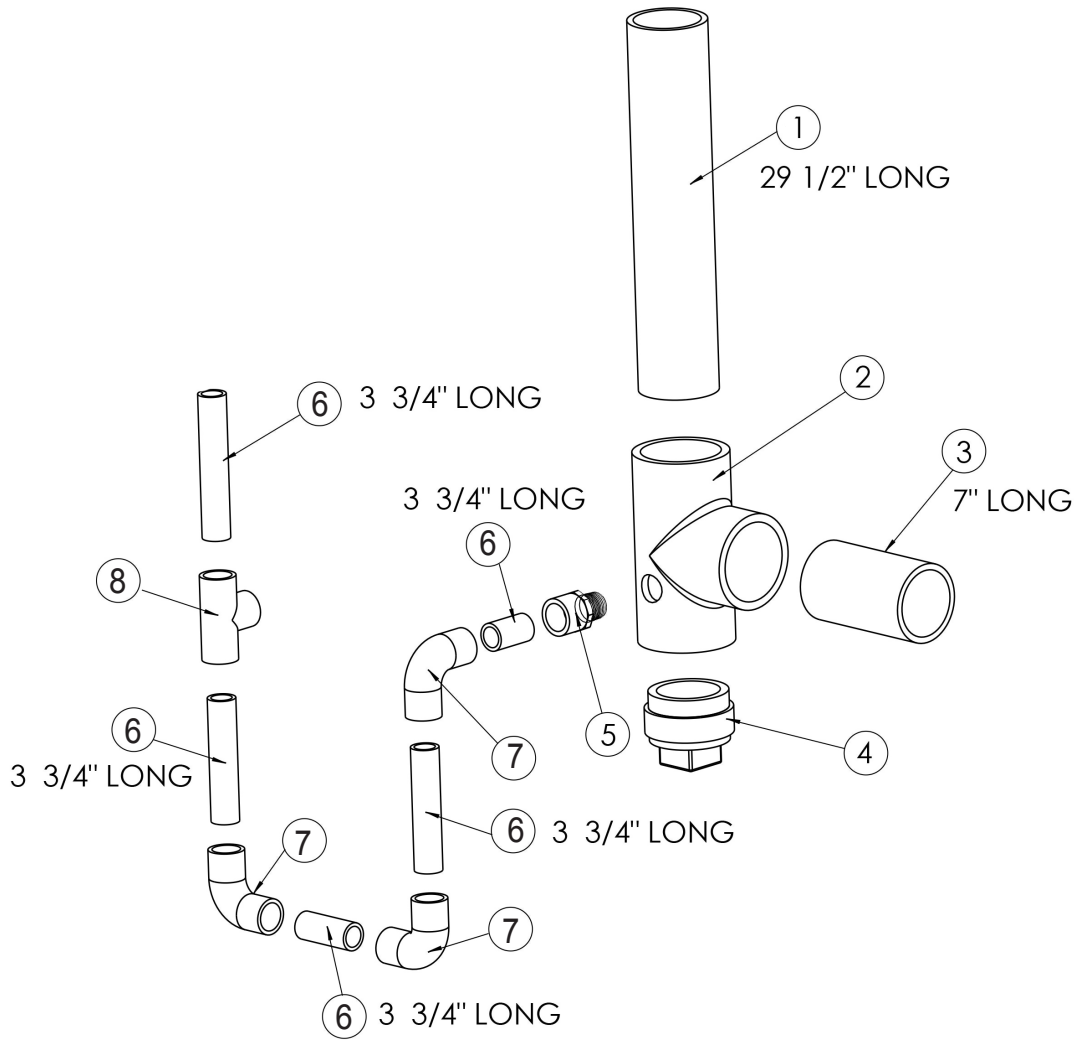

ITEM	PART NO.	DESCRIPTION	QTY.
1	240006820	Vent Pipe 2" CPVC SCH-40 x 29½" S636	2
2	3002223	Tee 2" CPVC SCH-80 S636, w/ hole	1
3	240006827	Vent Pipe 2" CPVC SCH-40 x 7" S636	1
4	240005852	Cleanout, PVC, 2"	1
*	240007536	Parts Bag, 90-200 Condensate (contains items 5-8)	
5	1001002	PVC Fitting ½" NPT Male x ½" Slip Female	1
6	240007262	Pipe ½" PVC SCH-40 x 3¾"	5
7	1190005	Elbow ½" x 90° PVC SCH-40	3
8	1510012	Tee ½" x ½" x ½" PVC SCH-40	1
*	29571	3" Concentric Vent Kit ULC S636	1
*	240006822	Coupling, 2" CPVC	1

[550002946](#) condensate Trap / Exhaust Tee Kit (contains items 2 thru 11 as well as parts for connecting to existing vent and condensate lines.)

* Not Shown

MIXER AND AIR PRESSURE SWITCH ASSEMBLY

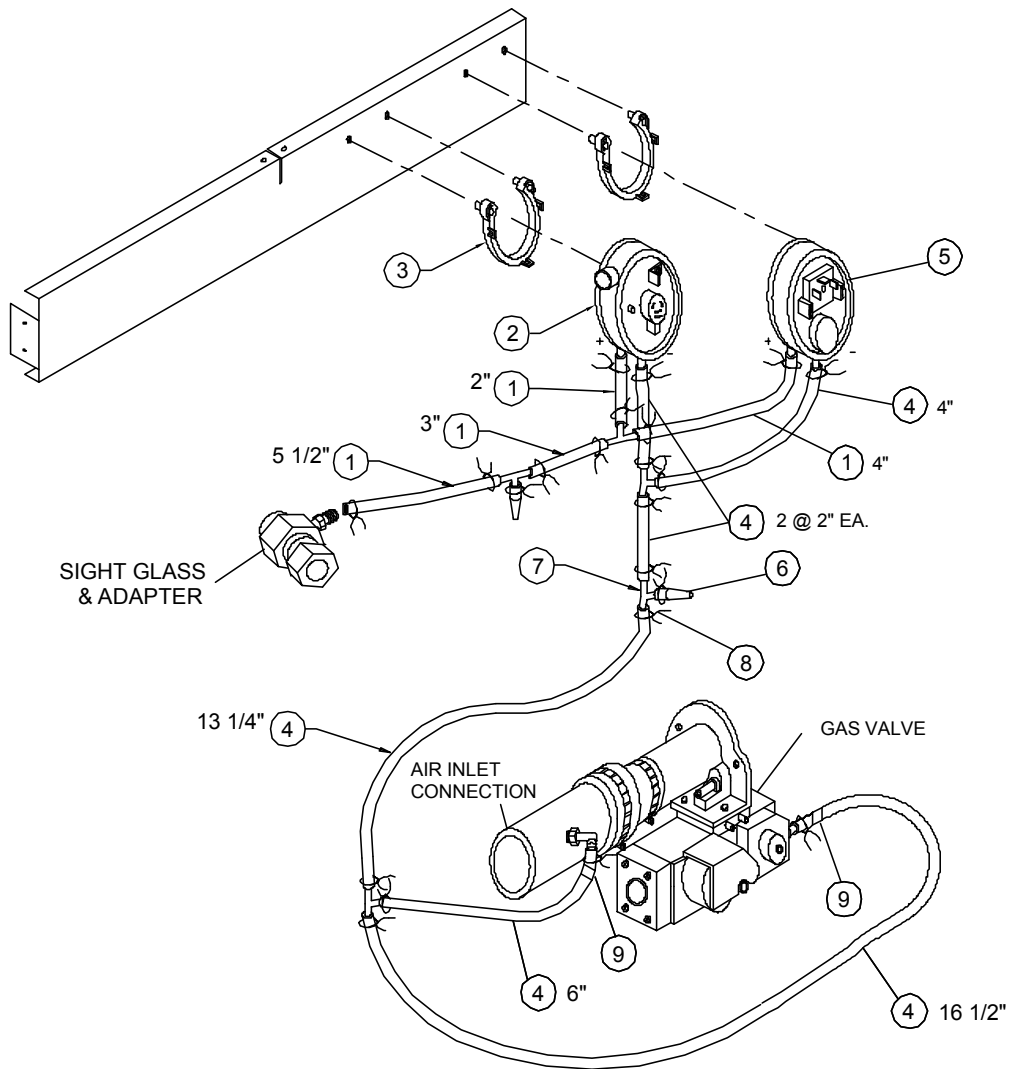

ITEM	PART NO.	DESCRIPTION	QTY.
1	1552014	Silicone Tubing, $\frac{3}{16}$ " I.D.	Varies
2	1401004	Air Pressure Switch, 3½" W.C.	1
3	1401002	Air Pressure Switch Clip	2
4	1552004	Orange Silicone Tubing, $\frac{3}{16}$ " I.D.	Varies
5	1401003	Air Pressure Switch. ½" W.C.	1
6	1230006	$\frac{3}{16}$ " Black Vinyl Cap	2
7	1510009	Plastic Barbed Hose Tee, $\frac{3}{16}$ " I.D.	5
8	1110001	Rotor Clamp	22
9	PB-002.02	Pilot Orifice, BBR10	2

FLUE ADAPTER AND EXHAUSTER ASSEMBLY

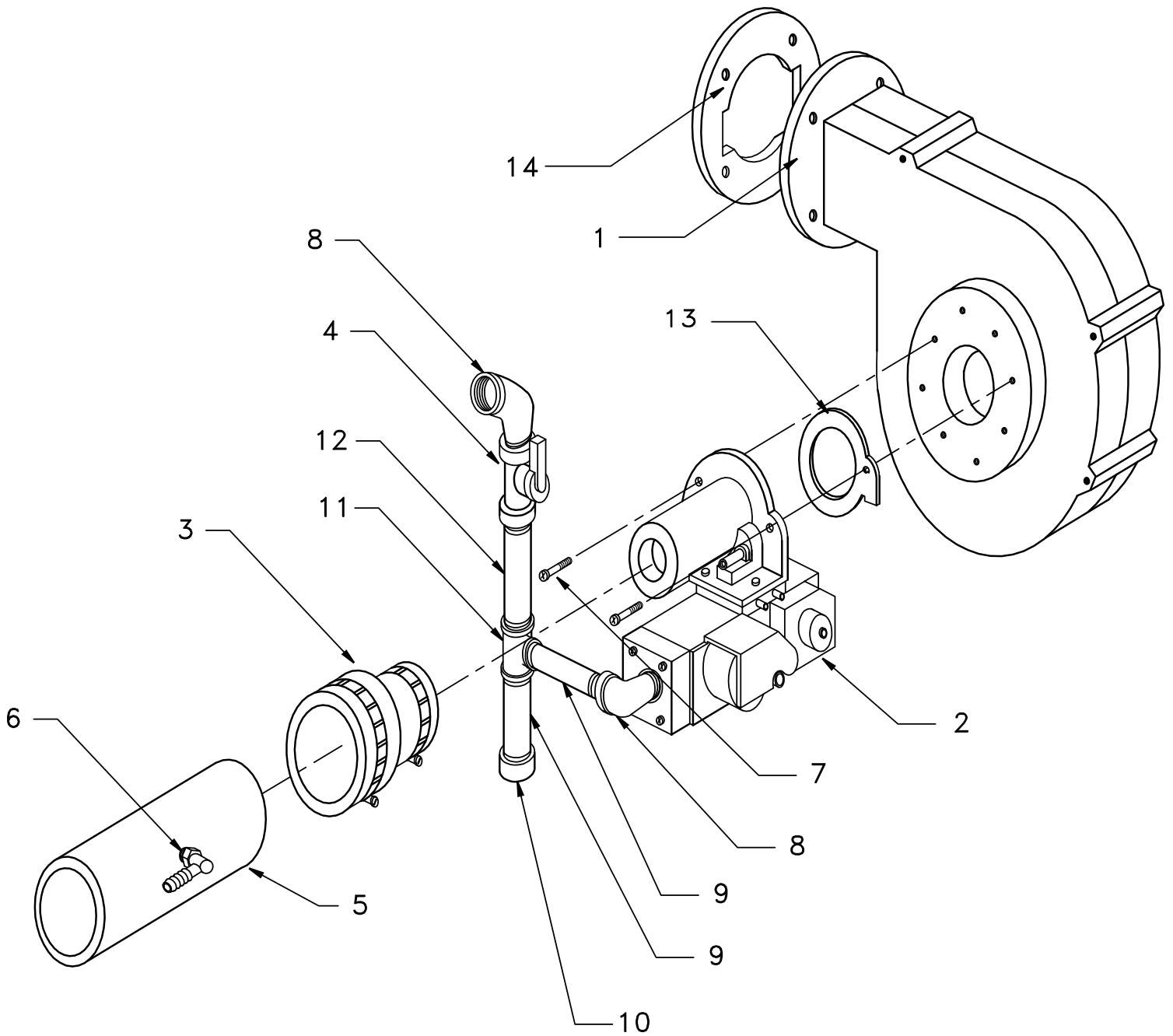

FLUE ADAPTER AND EXHAUSTER ASSEMBLY

ITEM	PART NO.	DESCRIPTION	QTY.
1	2272145	Blower Replacement Kit (includes #13 (below))	1
2	2272140	Gas Valve Replacement Kit (125 Only)	1
	2272141	Gas Valve Replacement Kit (150 Only)	1
	2272142	Gas Valve Replacement Kit (175 Only)	1
	2272143	Gas Valve Replacement Kit (200 Only)	1
3	14631311	2" x 1½" Flex Coupling	1
4	1570038	Ball Valve ½" (Blue)	1
5	1400007	Vent Pipe 2" PVC SCH-40 (8" Long)	1
6	1230011	Fitting, PE, ⅛" NPT" x ⅜", Barb 90°	1
7	1450012	Screw T25 Torx	2
8	14693801	Elbow Street Mall ½" - 90 PWX	2
9	14607301	Nipple Blk. Std. ½" NPT x 3"	2
10	1225015	Cap ½" Cast Iron	1
11	14657015	Tee Black ½"	1
12	14607803	Nipple Blk. Std. ½" x 4½"	1
13	1250021	Gasket, Cork, Venturi	1
14	1250007	Gasket, Fan Flue Adapter	1
*	1272033	Nat to LP Replacement Kit (125 Only)	1
*	1272034	Nat to LP Replacement Kit (150 Only)	1
*	1272035	Nat to LP Replacement Kit (175 Only)	1
*	1272036	Nat to LP Replacement Kit (200 Only)	1
*	1272037	LP to Nat Replacement Kit (125-200)	1

* Not Shown

Manufactured by:
ECR International, Inc.
2201 Dwyer Avenue, Utica NY 135041
web site: www.ecrinternational.com