



# CHEFTOP-BAKERTOP MIND.Map<sup>TM</sup>

## INSTALLATION MANUAL



USA

Read and understand this manual completely before attempting to install, operate, or service this equipment. This manual is intended for use only by qualified installers of electric appliances.

**RETAIN THIS MANUAL FOR FUTURE REFERENCE**

**⚠ WARNING**

## IMPORTANT FOR YOUR SAFETY

This manual is intended for use only by qualified installers of electric appliances to install and set up the Unox oven models listed on the cover of this document. It also contains operational instructions for the users of the appliance.

Keep this manual in an easily accessible place for future reference. In the event of a power failure, do not attempt to operate this appliance.

Keep the appliance area free and clear from combustibles.

Do not obstruct the air intake or exhaust openings of the appliance.

Keep in a prominent location instructions to be followed in the event the user smells gas. This information shall be obtained by consulting the local gas supplier.

### SAFETY PRECAUTIONS:

Do not store or use gasoline or other flammable vapors or liquids in the vicinity of this or any other appliance.

**⚠ WARNING**

Improper installation, adjustment, alteration, service or maintenance can cause property damage, injury, or death.

Read the installation, operating, and maintenance instructions thoroughly before installing or servicing this equipment.

The company reserves the right to apply improvement modifications to appliances and accessories at any time without advance notice.

## SAFETY REGULATIONS

FORWARD .....	4
SUPPLIED DOCUMENTS .....	4
REGISTRATION .....	5
EXPLANATION OF PICTOGRAMS .....	5
GENERAL SAFETY .....	6

## INSTALLATION

INSTALLATION .....	14
INITIAL PREPARATION .....	17
CHECKING PACKAGE CONTENTS .....	18
TECHNICAL DATA .....	19
INITIAL POSITIONING .....	20
POSITIONING .....	23
ELECTRICAL CONNECTIONS .....	29
GAS CONNECTIONS .....	31
PLUMBING .....	35
CONNECTIONS .....	35
FILLING THE DETERGENT TANK .....	41
SMOKE EXHAUST .....	43
OVEN RESETTING PROCEDURE .....	44
CONNECTING STACKED APPLIANCES (MAXI.LINK) .....	44
UNOX LIMITED WARRANTY CONDITIONS - US .....	45

# CHEFTOP MIND.Maps™

## Introduction

Congratulations and thank you for choosing to purchase a **CHEFTOP MIND.Maps™** oven.

The equipment is designed for the following purposes:

- for cooking all pastry and bread products, whether fresh or frozen;
- for cooking all gastronomic products, whether fresh or frozen;
- for bringing chilled and frozen food back to normal temperatures;
- for steam cooking meat, fish, and vegetables;
- for cooking vacuum-packed food in bags which are suited to that type of cooking procedure.

These ovens are also designed for use with complementary accessories such as a holding cabinet, special trays, and racks

UNOX S.p.A.

## FORWARD

This booklet shows the installation and use of **CHEFTOP MIND.Maps™** line of appliances, the maximum level of UNOX practicality and innovation.

The **CHEFTOP MIND.Maps™** line of ovens, together with their accessories, allow to complete cooking solutions using the **MAXI.Link** technology dedicated to superb cuisine, such as: **SlowTop** oven with temperature maintainer and combination of two or more ovens.

The **CHEFTOP MIND.Maps™ PLUS** models have digital control and the following capacities:

- 5 **GN 1/3** (only electric models);
- 5, 10 **GN 1/1** (electric/gas models);
- 6, 10FS **18"x26"** (electric/gas models);
- 16FS **18"x26"** (electric/gas models).



We recommend you thoroughly read this manual for all instructions on how to maintain the aesthetic and functional qualities of your purchased product intact.

## SUPPLIED DOCUMENTS

The following documents are provided with the unit:

- Installation and Operation Manual
- Overall Dimension Drawing
- Wiring Diagram
- Connection Diagram
- Exploded View Drawing

## REGISTRATION

The installation date and appliance model must be documented by the end purchaser. The model number and serial number are located on the serial plate similar to the one shown. Refer to **UNOX Limited Warranty Conditions - US** section on page 45 for additional details on registering the appliance.

Dealer:  
(The company where the UNOX appliance was purchased)

Installer:  
(The authorized service agent who installed the UNOX appliance)



Installation date:

## EXPLANATION OF PICTOGRAMS

The installation and user instructions are valid for all models unless otherwise specified by the following pictograms:



Danger! Situation presenting immediate danger, or a hazardous situation which could cause injury or death.



Danger: fire hazard!



Tips and useful information



Danger: electric shock!



Earthing symbol



Read the instruction manual



Equipotential symbol



Burning hazard



Consult other chapter

**⚠️ WARNING** Read this and other applicable manuals carefully before using this appliance. Incorrect installation, operation, maintenance, cleaning, or any modifications made to the appliance, may damage property or result in fatal injury.



## GENERAL SAFETY

**⚠️ WARNING** This appliance must only be used by qualified personnel to cook food in professional and industrial kitchens. Any other application that does not conform to the specified use is considered dangerous.

**⚠️ WARNING** The equipment must not be used by inexperienced or untrained persons. Always provide training and guidance on the proper use and shut down of the oven. Make sure all personnel are supervised by someone who is responsible for their safety.

**⚠️ WARNING** UNOX accepts no responsibility for any situation resulting from work carried out in

an unprofessional manner, or from the incorrect interpretation or application of regulations.

## GENERAL INSTALLATION

**⚠ WARNING** Incorrect installation or any modifications made to the appliance may damage property or result in injury or even death.

**⚠ WARNING** Fire risk! If the appliance is positioned near walls, partitions, kitchen cabinets, decorative trim, etc. (see Initial preparation on page **17**), these items must be made by a non flammable material. All fire prevention regulations must be strictly observed.

## ELECTRICAL

**⚠ WARNING** Electrical Grounding Instructions.

This appliance is equipped with a three-prong (grounding) plug for your protection against shock hazard and should be plugged directly into a properly grounded three-prong receptacle. Do not cut or remove the grounding prong from this plug.

**⚠ WARNING** Electrical connections or any work required on the electrical circuits inside the appliance, must be performed by certified technicians in compliance with local, state, and federal regulations.

**⚠ WARNING** Injury risk! A ground fault interruption circuit (GFI) must be installed.

**⚠ WARNING** Fire risk! Make sure all electrical connections are properly done.

## OPERATION

**⚠ WARNING** Fire risk! Do not place foods containing highly flammable ingredients (alcohol-based foods) in the oven. These substances may burst into flames and, therefore, constitute a fire and explosion hazard. Explosions may cause the door to open suddenly or even violently.

**⚠ WARNING** Fire risk! When using the appliance for the first time, make sure there are no instruction manuals, plastic bags, or accessories inside the oven.

**⚠ WARNING** Food contamination risk! Before cooking with the appliance, make sure there are no detergent or other caustic residues inside the oven. Remove any detergent residues using a damp cloth while wearing suitable eye and hand protection, then rinse the oven thoroughly.

**⚠ WARNING** Burn risk! Always wear heat-resistant gloves when handling accessories or other objects which have been inside the hot oven.

**⚠ WARNING** Burn risk! Make sure any hanging rack frames and/or tray rack trolleys inside the oven are secured. Improperly placed containers holding hot liquids may fall or slip inside the oven causing the potential for burns.

**⚠ WARNING** Burn risk! The temperature of the external parts of the oven may exceed 140 °F (60 °C). Touch only the components used to control the appliance.

**⚠ WARNING** Burn risk! When containers are full of liquid or will be filled with liquid during the cooking process, the user must be able to see inside each container. Do not place any racks above eye level.

**⚠ WARNING** Burn risk! Take extra care to avoid drips or spills when removing trays containing hot liquids.

**⚠ WARNING** Burn risk! The maintenance operations of the unit must be carried out by qualified and trained personnel

only when the appliance is empty and disconnected from power supply and water connections.

**⚠ WARNING** This appliance can be used by children aged from 8 years and above and persons with reduced physical, sensory or mental capabilities or lack of experience and knowledge if they have been given supervision or instruction concerning use of the appliance in a safe way and understand the hazard involved. Children shall not play with the appliance. Cleaning and user maintenance shall not be made by children without supervision.

**⚠ WARNING** Burn risk! Always open the door slowly and carefully to prevent being burned by hot steam escaping from the oven.

**⚠ WARNING** Burn risk! Do not leave the core probe hanging outside the oven door, as this could damage the probe and cause hot steam or liquid to escape from the oven during the cooking process. Always remove the core probe from the food before removing it from the oven.

**⚠ WARNING** Burn risk! If the tray rack trolleys need to be moved while in use, always make sure the containers are secured properly. Close the containers holding liquids so that no hot liquid can spill out.

## INSPECTION AND MAINTENANCE

**⚠ WARNING** For gaining access for servicing, remove from the installed position the oven to get access to the service panel on the back.

**⚠ WARNING** Injury risk! When loading and unloading the tray rack trolley, apply the wheel lock brake.

**⚠ WARNING** Injury risk! Tray rack trolleys may tip over when wheeled along uneven surfaces or when crossing the threshold of a door.

**⚠ WARNING** Electrocutation and burn risk! To reduce the risk of fire and/or electric shock do not remove the service panels. There are no user serviceable items under the service panels. Only qualified service agents are permitted to remove the service panels.

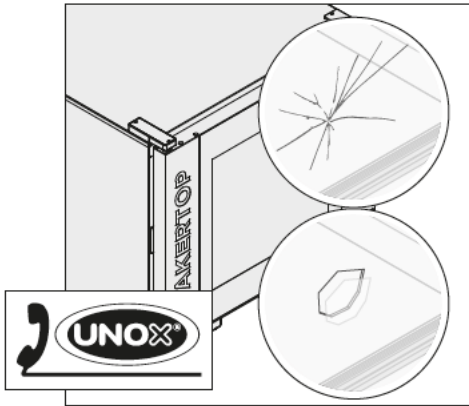

If the appliance glass is chipped or damaged, it must be replaced immediately by contacting an authorised support service centre. Do not use the oven. Risk of exploding glass.

## CLEANING AND REPAIR WORK SAFETY

**⚠ WARNING** Fire risk! If the appliance is not cleaned or not cleaned thoroughly, grease or remnants of food which have accumulated inside the oven may start to burn.

**⚠ WARNING** Injury risk! Appliance maintenance must only be performed by suitably trained personnel.

**⚠ WARNING** Injury risk! Before any maintenance work is performed, the appliance must be disconnected from the electrical and gas supply. Apply a lock out tag to the electrical and gas supply connection.

**⚠ WARNING** Injury risk! Repair work must only be performed by UNOX or one of its qualified service agents. UNOX accepts no responsibility for any situation resulting from work performed by untrained technicians.

**⚠ WARNING** Injury risk! All parts not supplied by UNOX must be pre-approved before installation.

**⚠ WARNING** Appliances must be installed in areas:

- that comply to the safety requirements called for by the standards in force;

- that have adequate ventilation. Make sure that air is continually refreshed from the outside to ensure correct combustion and to avoid the formation of volatile substances hazardous to health - risk of suffocation!

• Make sure:

- that installation is performed by respecting the safety regulations of the country of use and of the gas company;

- that the ventilation inlets and the appliance exhausts are not obstructed (e.g. objects and walls);

- that the type of gas available corresponds to the type indicated on the appliance;

- that the gas pipe diameters meet the required measurements;

- that components - not supplied by UNOX - used for installation comply with the regulations in force of the country of use;

- that the connection pipe pressure equals that of the gas supply inlet;

- that maximum gas piping inlet pressure is 55 mbar; pressures may not exceed this threshold.

• After connection to the gas supply, check for gas leaks of the components by preferably using non-corrosive foams. Never use flames!

• Upon commissioning a qualified technician authorised by UNOX must analyse the burner exhaust gases (CO and CO<sub>2</sub>) and record the registered values on the appliance.

• Always maintain the smoke exhaust pipe, that is located on the top portion of the oven, free of obstructions (e.g. objects, trays, etc...) .

- Always switch-on the hood if installed when using the appliance
- If the appliance is connected to a smoke flue, this must be:
  - kept free of any obstructions - risk of fire!
  - regularly cleaned and inspected as called for by the relative standards of the country of use - risk of fire!
- The appliance must be installed far from air currents or drafts - risk of fire!
- Make sure that ventilation inlets and the underlying part of the appliance are clean and free of obstructions (e.g. objects near the appliance).
- If the odour of gas is detected:
  - immediately isolate the gas supply;
  - notify the Emergency Services immediately.

## WARNINGS REGARDING WASHING CYCLES

The ovens come equipped with one/two rotor(s) for cleaning the oven cavity.

**⚠ WARNING** Burn risk! Do not open the oven door during washing. There is danger of severe caustic burns from the presence of hot air, acids, or basics that may come in contact with the skin and/or eyes. If the washing program is stopped before its completion, launch and complete a LH2O WASHING program before opening the door.

**⚠ WARNING** Before starting a cleaning cycle, make sure that there are NO trays in the oven chamber, otherwise the washing is ineffective.

**⚠ WARNING** Carefully read the product safety data sheet before handling and using the detergent.

**⚠ WARNING** Do not open the oven door during washing as this could cause injury to eyes, mucous membranes and skin caused by contact with the cleaning chemicals used. These chemicals are sprayed by the rotor within the cooking chamber and moved by strong air currents.

**⚠ WARNING** For ovens with a trolley, run the washing cycle with the trolley inside the oven cavity, without any trays, and lock the trolley using the front wheel brakes.

## Installation

### INSTALLATION CODES AND STANDARDS

Installations within the United States, must follow:

- 1. State and local codes.
- 2. National Electrical Code, ANSI/NFPA No.70, (latest edition) available from the National Fire Protection Association, Batterymarch Park, Quincy, MA 02269.
- 3. Vapor Removal from Cooking Equipment, NFPA-96, (latest edition) available from NFPA.
- 4. (only for gas appliance) Gas Food Service Equipment, ANSI Z83.11/CSA 1.8
- 5.(only for gas appliance) National Fuel Gas Code, ANSI Z223.1/NFPA 54, (latest edition) available from NFPA.
- 6. Commercial cooking, rethermalization and powered hot food holding and Transport equipment NSF/ANSI 4-2009.
- 7.(only for gas appliance) Commercial Electric Cooking Appliances, UL197.
- 8. Commercial Cooking Appliances, CSA C22.2 No.109 - M1981.

Installations within Canada, must follow:

- 1. Local codes.
- 2. Canadian Electrical Code, CSA C22.2 No.3, (latest edition) available from the Canadian Standards Association, 5060 Spectrum Way, Mississauga, Ontario, Canada L4W 5N6.
- 3.(only for gas appliance) Gas Food Service Equipment, ANSI Z83.11/CSA 1.8

- 4. Commercial Electric Cooking Appliances, UL197.

- 5. Commercial Cooking Appliances, CSA C22.2 No.109 - M1981.

Notice: for the appliances equipped with casters, the installation shall be made with a connector that complies with the Standard for Connectors for Movable Gas Appliances, ANSI Z21.69 • CSA 6.16, and a quick-disconnect device that complies with the Standard for Quick-Disconnect Devices for Use With Gas Fuel, ANSI Z21.41 • CSA 6.9, (2) adequate means must be provided to limit the movement of the appliance without depending on the connector and the quick-disconnect device or its associated piping to limit the appliance movement and (3) the location(s) where the restraining means may be attached.

## DELIVERY AND INSPECTION

UNOX strives to ensure the appliance is received in good working condition. To prevent shipping damage, the appliance is shipped from the factory and must only be transported using pallets supplied by UNOX. Each unit has been carefully inspected before it was packaged and consigned to a shipper/installer.

Upon delivery:

Inspect the shipping container, carefully noting any exterior damage on the delivery receipt, which must also be signed by the driver or delivery person.

- Unpack and check for any damage, which was not evident on the outside of the shipping container.
- Check for concealed damage. The carrier must be notified immediately of damage not readily visible upon the delivery of the unit. The crate and all packaging materials must be retained for inspection.

UNOX does not assume liability for loss or damage of the appliance during shipping and/or delivery. The carrier assumes full responsibility for delivery in good condition when the shipment was accepted. If the product was lost or damaged in shipment UNOX will provide assistance in filing a claim with the carrier.

## HANDLING

The appliance is very heavy and may require the use of moving equipment.

**⚠️ WARNING** Injury risk! Do not lift or move the appliance without adequate help. Heavy lifting, over 51 pounds (23 kg), may result in personal injury. Make sure the appliance is not in danger of tipping over during transportation.

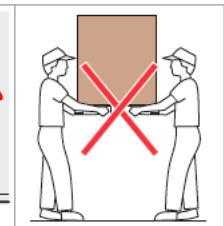
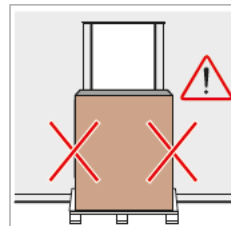
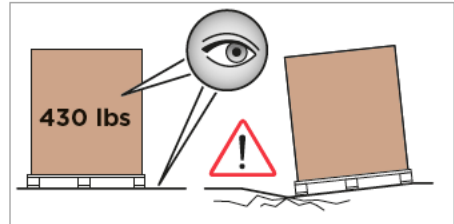
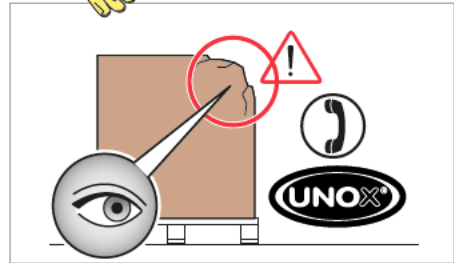

1 person necessary for installation

## SPECIFICATIONS

Before positioning the appliance, check the measurements and the exact position of the electrical, gas (only for gas appliance) plumbing, and exhaust connections. Check for proper clearance (see page 20) with shut off valves and drain line hook ups.

The installation site must be able to withstand the maximum weight of the fully loaded appliance. Make sure the unit fits through all doors, corridors, passageways, or other openings required to reach the installation site.

 The packaging materials, given their potential danger, must be kept out of reach of children and animals, and correctly disposed of in compliance with local regulations.

## NON-STOP Efforts

UNOX has followed the **NON-STOP Efforts** philosophy for years to increase the environmental compatibility of its products to reduce energy consumption and waste. UNOX wishes to protect the environment and invites the consumer to dispose of waste in recycling bins.

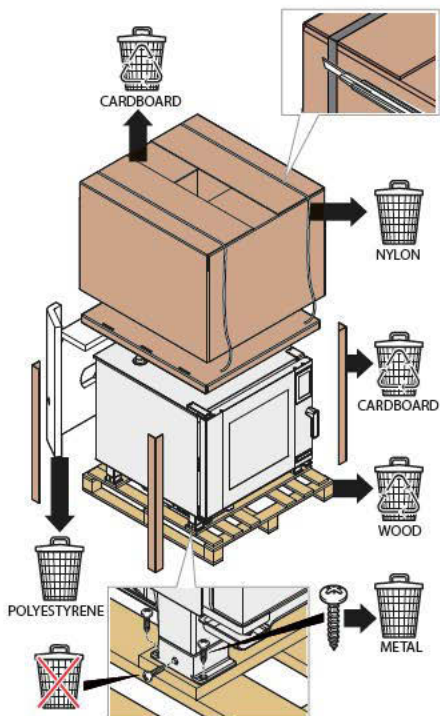

**⚠ WARNING** Fire risk! Any work on the oven, must be performed by certified technicians in compliance with local, state, and federal regulations.

## 1 INITIAL PREPARATION

### REMOVING THE FILM

Slowly remove the protective films from the appliance: clean any glue residues with appropriate solvents without using tools, abrasive detergents or acids that could ruin the surfaces.

⚠ The removed film, given its potential danger, must be kept out of reach of children and animals; and correctly disposed of in compliance with local regulations.

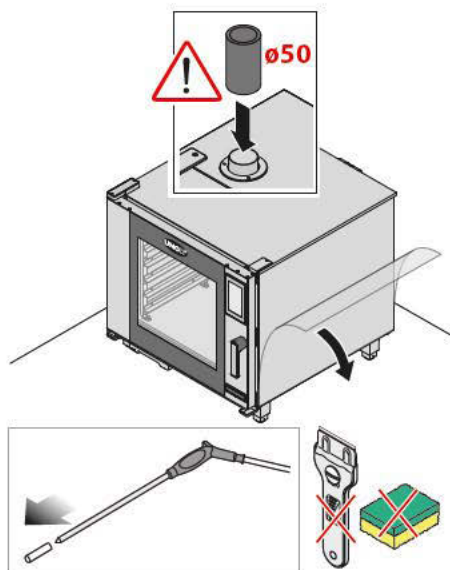

## 2 CHECKING PACKAGE CONTENTS

Before installing the appliance, check that the following packaged components are present and free of damage.

! Contact UNOX if a component is missing or damaged.

### COUNTER TOP OVENS

- ① oven designed for:
  - **electrical connections** (power supply cable already assembled);
  - **plumbing** (water supply tube, mechanical filter, 3/4 connection with non-return valve already assembled);
  - **Natural Gas connection** (only for gas appliance);
- ② technical documents (installation and use booklet, “Technical data” sheet);
- ③ 4 plastic supports;
- ④ “Starter Kit” bag (8 self-tapping screws, 1 connection spanner, 1 falling liquids adhesive label).

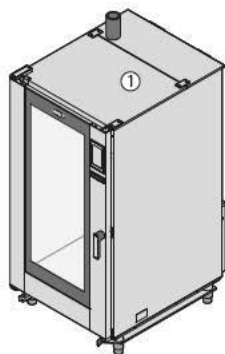
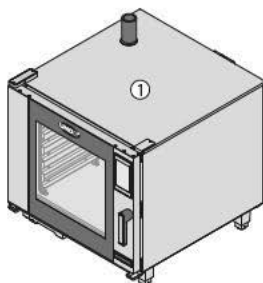

### FREE STANDING OVENS WITH/WITHOUT TROLLEY

- ① oven designed for:
  - **electrical connections** (power supply cable already assembled);
  - **plumbing** (water supply tube, mechanical filter, 3/4 connection with non-return valve already assembled);
  - **Natural Gas connection** (only for gas appliance);
- ② technical documents (use and installation manual, “Technical specifications” sheet);
- ③ 2 plastic supports;
- ④ 1 “Starter Kit” bag (8 self-tapping screws, 1 attachment spanner, 1 falling liquids adhesive label);
- ⑤ trolley (only for models with trolley).

# TECHNICAL DATA

		Trays type	Oven Model**	Dimension [inches - mm]	Weight* [lbs - Kg]	Electric power	Gas Power
<b>COMPACT</b>	<b>GN 1/3</b>	5	XACC-0513 EPxM	21" 1/16 x 34" 5/16 x 25" 9/16 535x872x649	140 lbs 65kg	5,8-7,7 kW 208-240 V 3~ 60Hz	
	<b>GN 1/1</b>	5	XAVC-0511-EPxM	29" 1/2 x 30" 1/16 x 25" 9/16 750x783x675	152 lbs 69kg	5,8-7,7 kW 208-240 V 3~ 60Hz	
		5	XAVC-0511-GPxM		185 lbs 85kg	0,6 kW 120V 1~ 60Hz	15 kW
		10	XAVC-1011-EPxM	21" 1/16 x 34" 5/16 x 39" 93/4 750x783x1010	165 lbs 75kg	12-15,5 kW 208-240 V 3~ 60Hz	
		10	XAVC-1011-GPxM		262 lbs 119kg	1 kW 120V 1~ 60Hz	19 kW
		20	XAVL-2021-DPxS	35" 1/8 x 49" 1/2 x 73" 13/16 892x1257x1875	785 lbs 356 kg	53,7-71 kW 208-240 V 3~ 60Hz	
		20	XAVL-2021-GPxS	35" 1/8 x 49" 1/2 x 73" 13/16 892x1257x1875	815 lbs 370 kg	2,6 kW 120V 1~ 60Hz	90 kW
		20	XAVL-2021-NPxS	35" 1/8 x 49" 1/2 x 73" 13/16 892x1257x1875	747 lbs 339 kg	2,6 kW 208-240 V 1PH+N+PE	90 kW
	<b>18"x26"</b>	6	XAVC-06FS-EPxM	33" 7/8 x 38" 1/16 x 33" 3/16 860x967x843	242 lbs 110kg	14,3-19 kW 208-240 V 3~ 60Hz	
			XAVC-06FS-GPxM		287 lbs 130kg	1 kW 120V 1~ 60Hz	33 kW
10		XAVC-10FS-EPxM	33" 7/8 x 38" 1/16 x 45" 13/16 860x967x1163	320 lbs 145kg	21,6-29 kW 208-240 V 3~ 60Hz		
		XAVC-10FS-GPxM		384 lbs 174kg	1,4 kW 120V 1~ 60Hz	33 kW	
16		XAVC-16FS-EPxM	34" 3/4 x 41" 1/16 x 73" 1/2 882x1043x1867	573 lbs 260kg	36-47,8 kW 208-240 V 3~ 60Hz		
		XAVC-16FS-GPxM		639 lbs 290kg	2,2 kW 120V 1~ 60Hz	70 kW	

\* The values refer to the appliance when empty.

\*\* The letter "x" means the right or left door opening.

### 3 INITIAL POSITIONING

#### CHARACTERISTICS OF THE INSTALLATION AREA

Install the appliance in areas:

- dedicated and conforming to the cooking of industrial foods;
- having adequate air ventilation;
- that comply with the laws in your country;
- protected against the weather;
- with temperatures between 41 °F to 104 °F maximum (5 °C to 35 °C);
- having a maximum humidity of 70%.

In case of gas appliances, the law requires gas appliances to be installed in areas:

- with surface area and ventilation suitable for oven gas combustion;
  - with outdoor evacuation of exhaust gas.
- For additional information consult chapter **SMOKE EXHAUST** at page **43**.

The law requires gas appliances to be installed in areas:

- with surface area and ventilation suitable for gas combustion;
- with outdoor evacuation of exhaust gas.

⚠ Do not install the appliance near other appliances that reach high temperatures in order to avoid damaging electrical parts.

The appliance is not suited for recessed installation.

Make sure that the floor supports the weight of the appliance at full capacity.

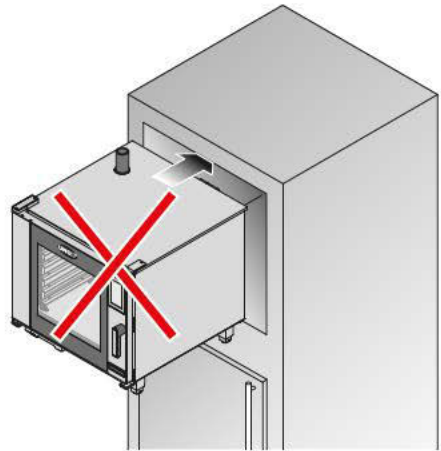
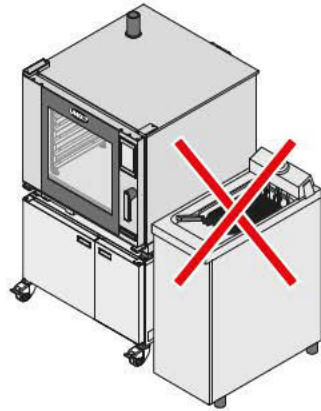



📄 For additional technical information on the appliance, consult the "technical specifications" sheet attached to the appliance.

⚠ The floor beneath the appliances must:

- be flame and heat resistant;
- be perfectly level;
- have a flat and even surface;
- are able to support the appliance weight at full load without undergoing deformation or structural failure.

The installation areas must be equipped with electrical, plumbing and gas utilities (only for gas ovens) that comply with the regulations of the country of use.

The figure gives indicative connection measurements:

-  electrical connection
-  plumbing connection
-  gas connection (only for gas appliances)

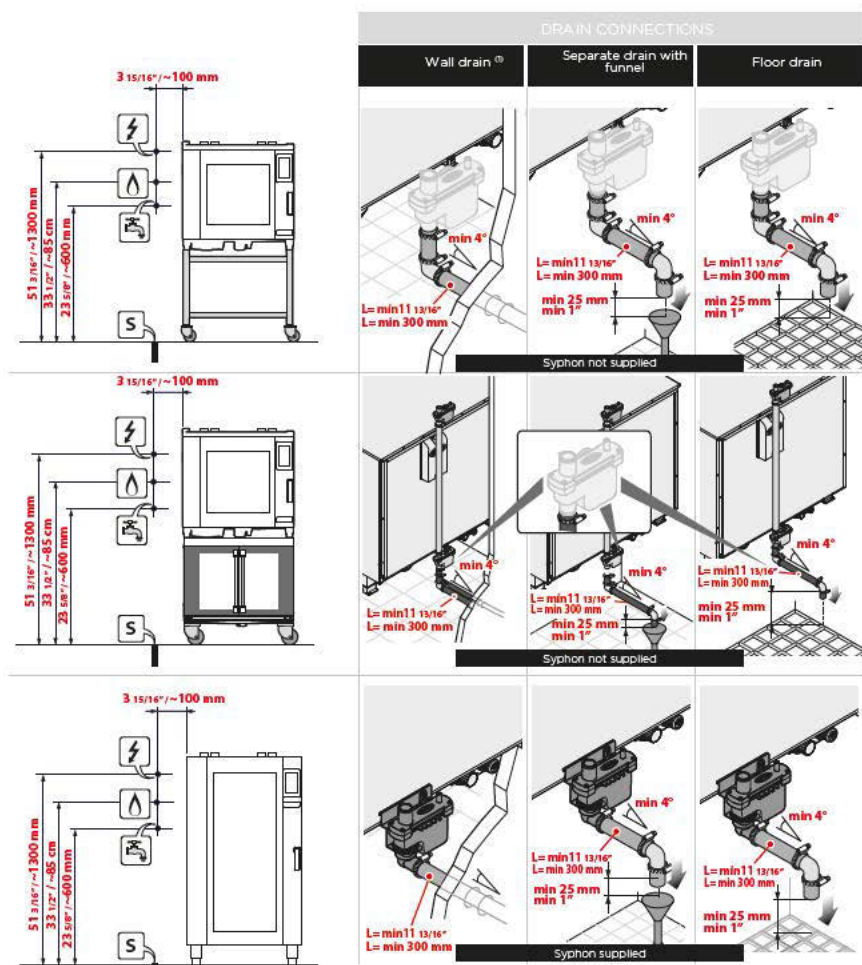

(1): The wall-mounted exhaust output must have an air gap of at least 1" (25 mm).

USA

## APPLIANCE DISTANCES

Position the appliance respecting the distances in the figure so the back panel is easily accessible when performing electrical connections or for maintenance work.

 Do not install the appliance near easily inflammable or heat sensitive materials or combustible constructions. Otherwise, protect them with appropriate non-inflammable materials in compliance with fire prevention regulations.

 If the top shelf is higher than 63" (160 cm) apply "the maximum height of the last shelf for containers holding liquids" warning label at the height shown in the figure. The safety label is located in the "starter kit".

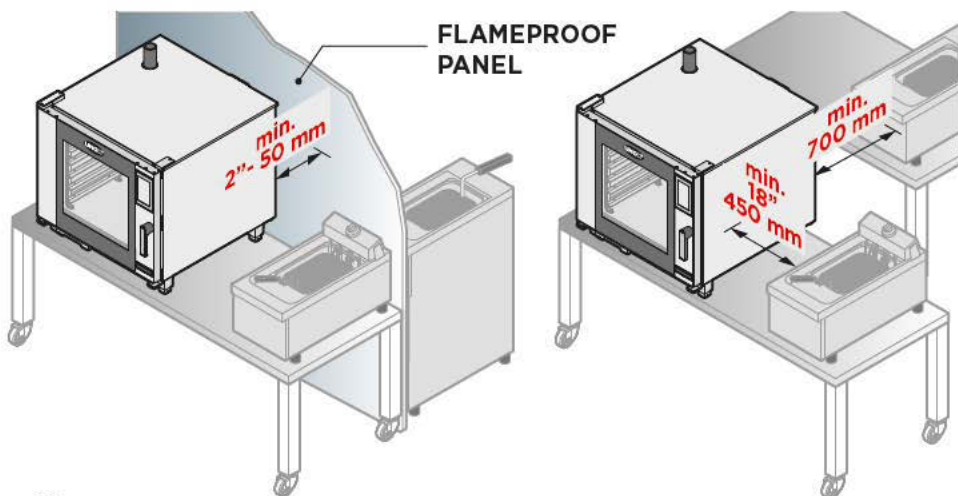
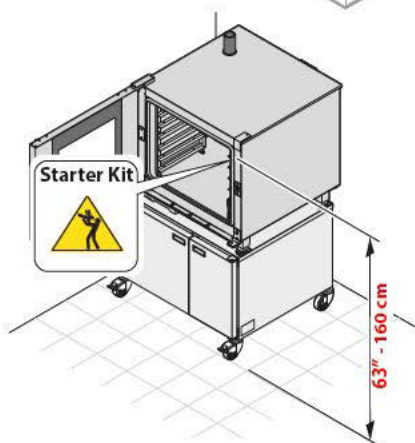
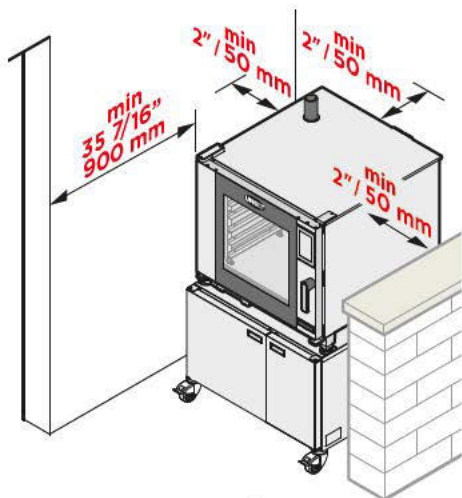

## 4 POSITIONING

### COUNTERTOP OVENS

⚠ Do not use appliances without feet or directly on the floor: this may cause permanent damage to the equipment.

The counter top ovens can be positioned:

- **stacked on UNOX accessories equipped with casters.** Use UNOX's oven stacking kit when stacking multiple units. It maintains the proper distance between appliances and simplifies electrical, plumbing and exhaust connections. Follow the instructions on the packaging for stacking kit assembly.

- **on table strong enough to support a fully loaded unit** (electrical appliances). If leveling is required, loosen three of the four screws that secure the plastic supports to the oven legs, adjust the feet to level the unit and then re-tighten the three screws. Note: never unscrew the feet past the MAX limit line. Use the screws provided to secure the support feet to the table top.

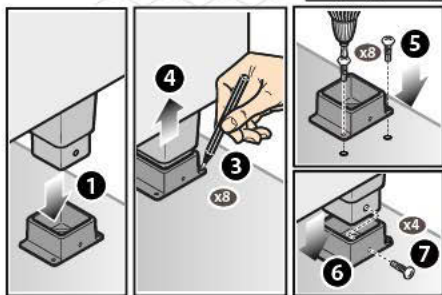
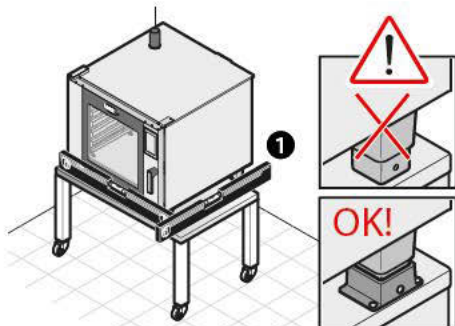
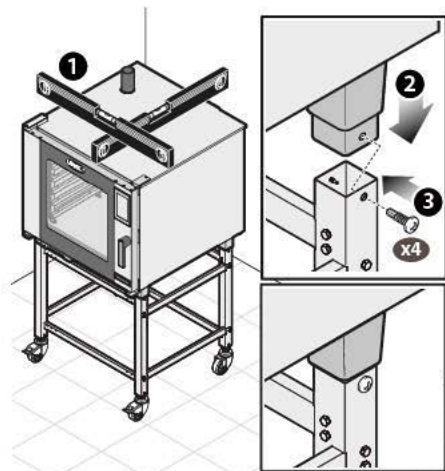

## POSITIONING: APPLIANCE STACKING (MAXI.LINK)

Use UNOX's oven stacking kit when stacking multiple units. It maintains the proper distance between appliances and simplifies electrical, plumbing and exhaust connections.

Follow the instructions on the packaging for stacking kit assembly.

❗ The oven should never be placed immediately above other ovens or other sources of heat.

❗ The detergent tanks are always installed under the oven / lowest SlowTop!

⊕ The oven stacking kit also contains a siphon and a Tee fitting for plumbing several appliances with a single water outlet.

## EXAMPLES OF POSSIBLE COMPOSITIONS:

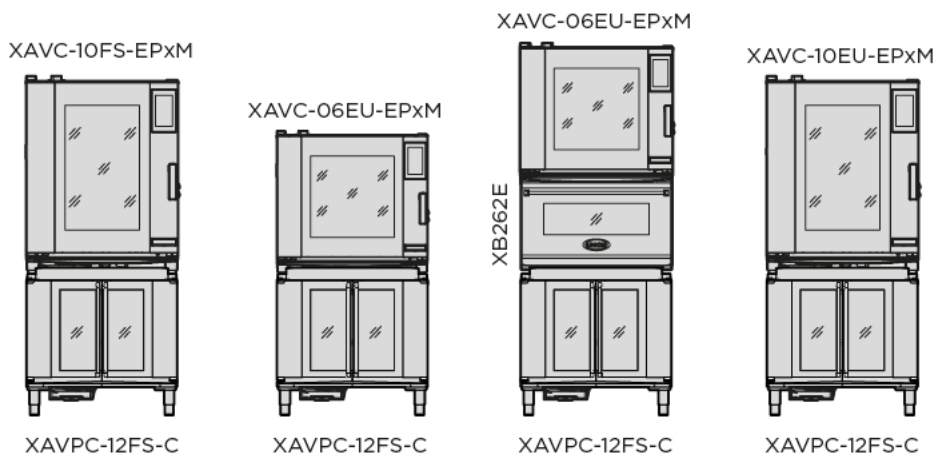

## FREE-STANDING OVENS WITH/WITHOUT TROLLEY

Ovens of this type must be set on floors that meet the following requirements:

- be flame and heat resistant;
- be perfectly level;
- have a flat and even surface;
- are able to support the appliance weight at full load without undergoing deformation or structural failure.

## LEVELLING THE APPLIANCE

To ensure the correct positioning of the trolley inside the oven and to make sure the unit is square, it is necessary to check and possibly adjust the feet.

- ① Make sure the length of the oven cavity diagonals are the same, if this is not the case, it implies that the appliance is not flush.
- ② Regulate one of the two front feet to maintain a minimum height of 6-3/4" (173 mm).

❗ It is compulsory to anchor the 4 front supports to the floor to avoid the oven ralling over (see diagram on the following page).

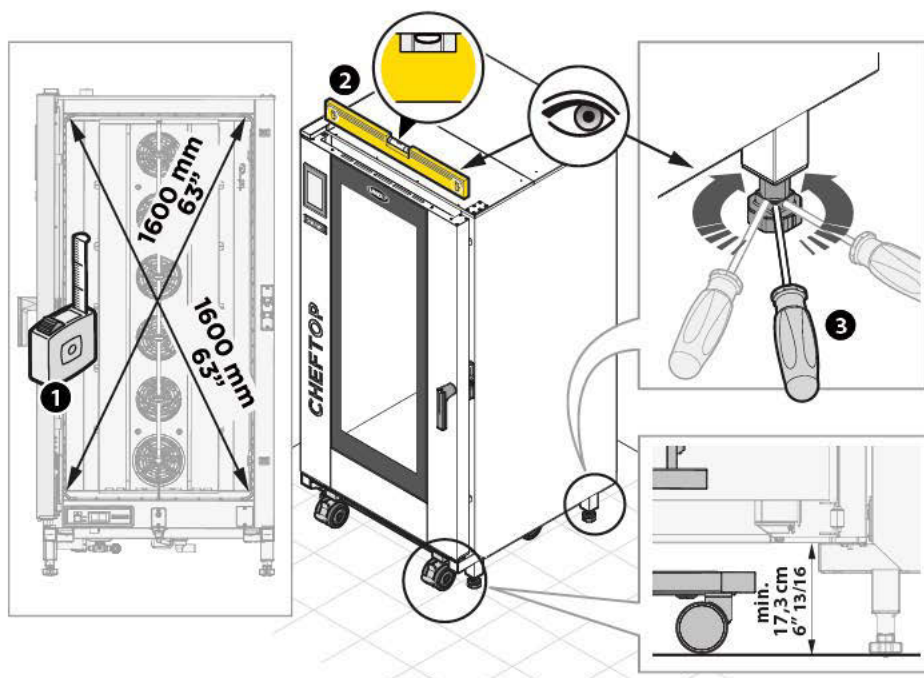

SOLUTION - A

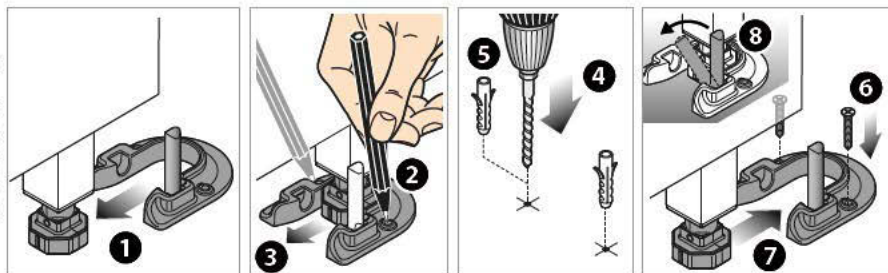

SOLUTION - B

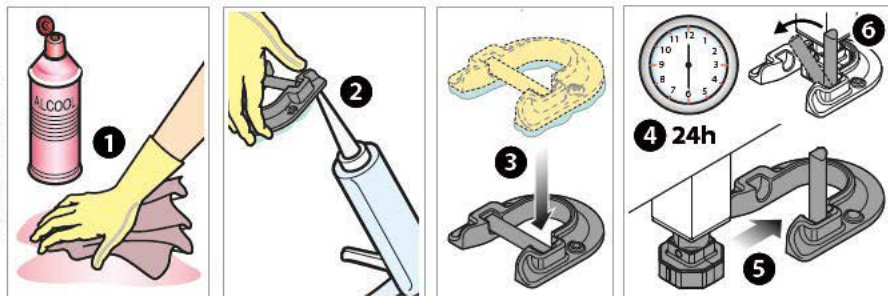

## ONLY FOR FREE-STANDING TROLLEY OVENS

If the floor is not perfectly level, a loading ramp with a maximum incline of 4° may be used to simplify the loading of the trolley. The maximum floor incline allowed is 2°.

! If floor incline exceeds this value, hot liquids may spill from the trays during loading/extraction and cause burns.

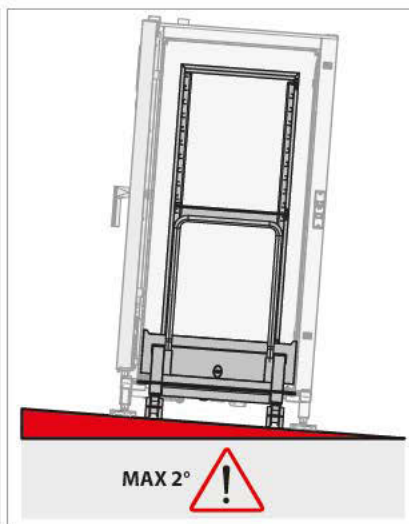
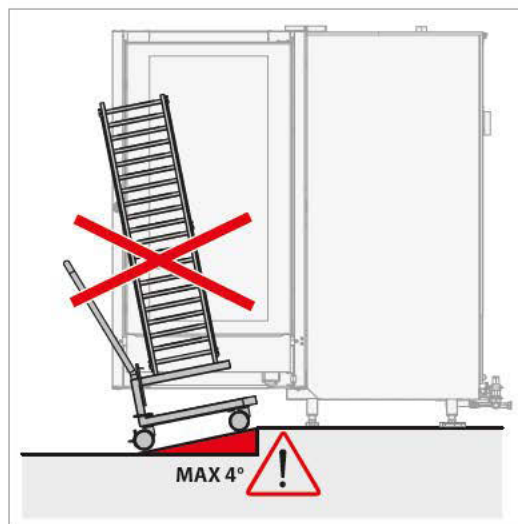

# TELESCOPIC SPACER

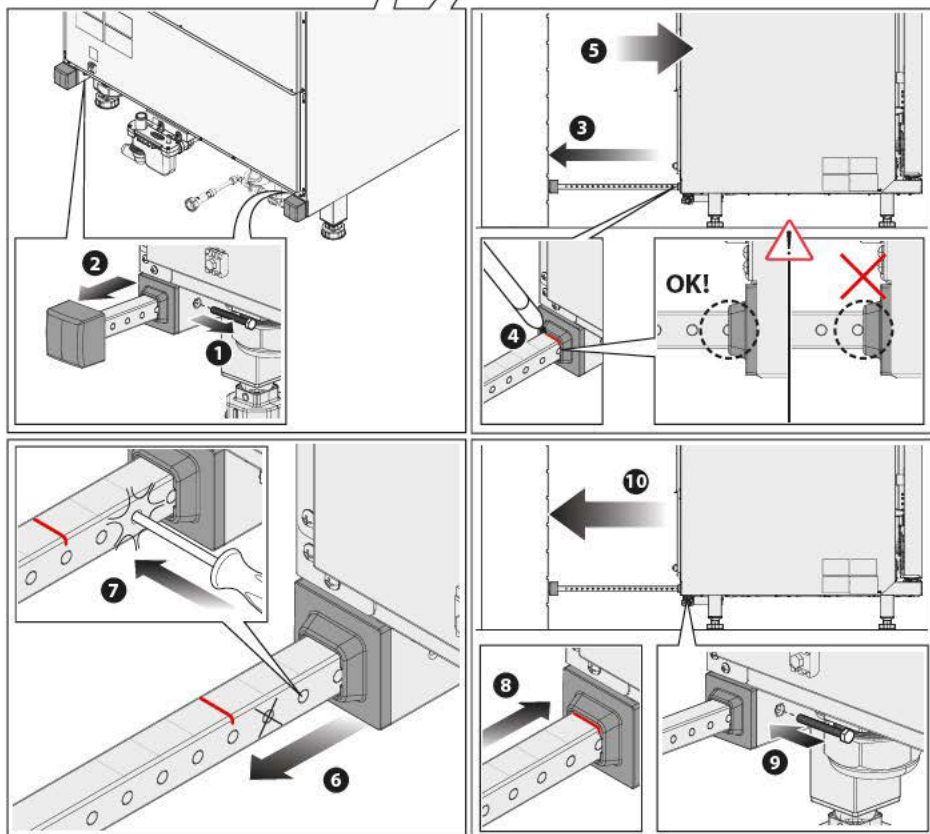
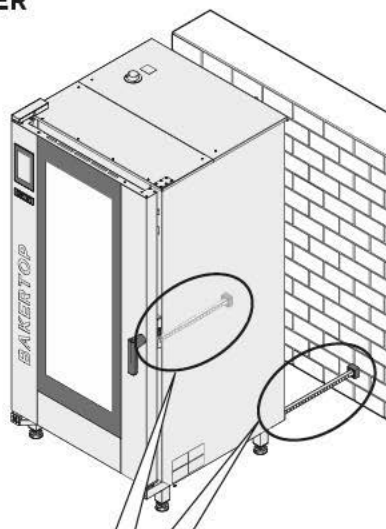

USA



**!** ALL THE GAS APPLIANCES must be fixed to the rear walls by using Unox chains kit supplied with the appliance. In the figure below the instructions to fix the ovens are shown.

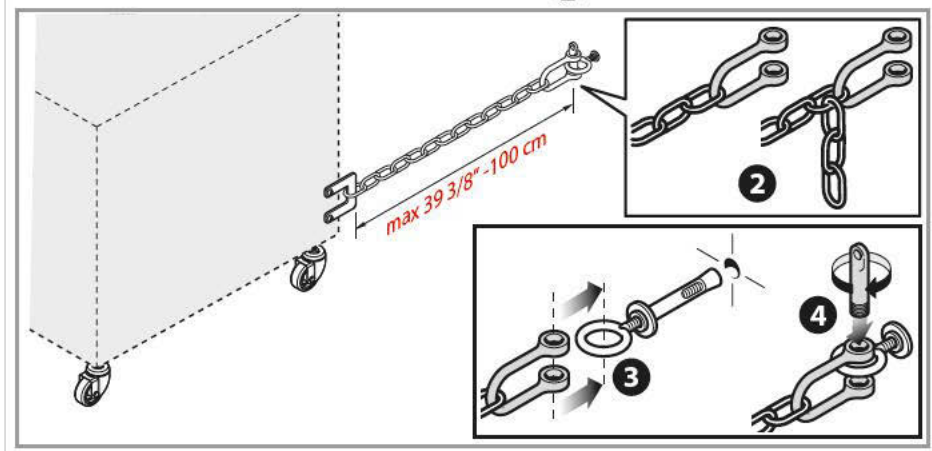
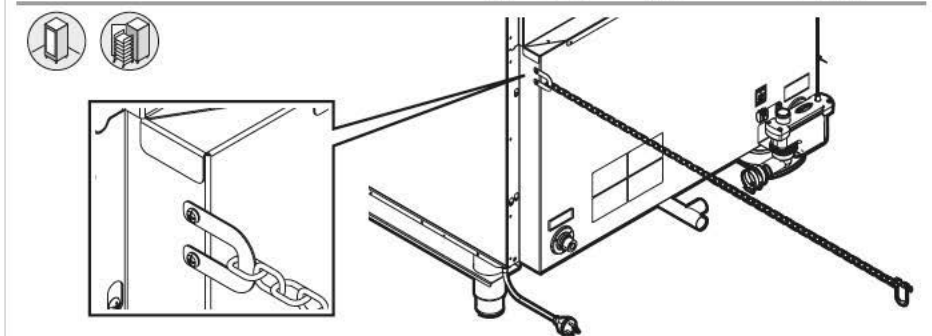
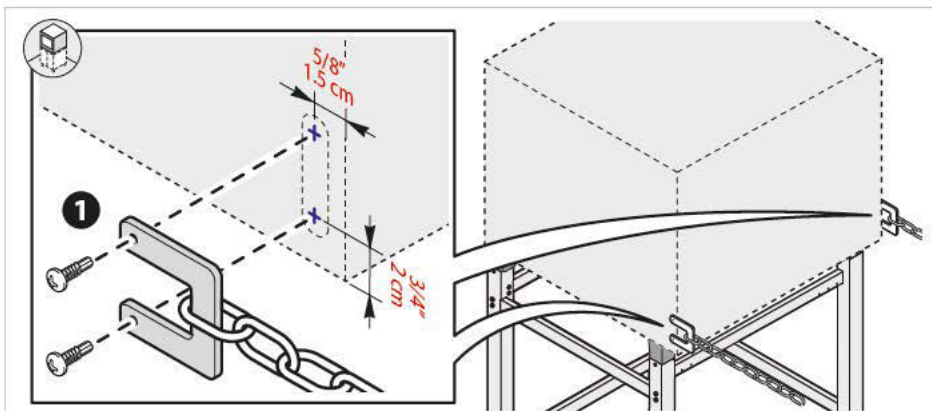

## 5 ELECTRICAL CONNECTIONS

**⚠ WARNING** Injury risk! Read and follow ALL safety instructions on page 2 and **Installation codes and standards** on page 14.

### WIRE COLOR CODING

**⚠ DANGER** Electric shock risk! observe the color coding of the wires. incorrect connection can lead to personal injury or even electrocution.

**!** Incorrect connection of the electrical wires may damage the appliance.

Grey or white = neutral wire  
Black, red, blue = phase L1, L2, L3”

### GENERAL INFORMATION

Before connecting the oven to the electrical supply, compare the power supply data, specified on the rating plate, with the appliance requirements specified on its rating plate. The appliance when installed must be electrically grounded in accordance with local codes, or in the absence of local codes, with the National Electrical Code, ANSI/NFPA 70, or the Canadian Electrical Code, CSA C22.2, as applicable. Use a digital multimeter when performing the following checks.

① If the voltage and power supply phases are different, adjust and correct the phase wiring, in accordance with the data provided with the appliance.

② Make sure there is no electrical discharge between the phases and

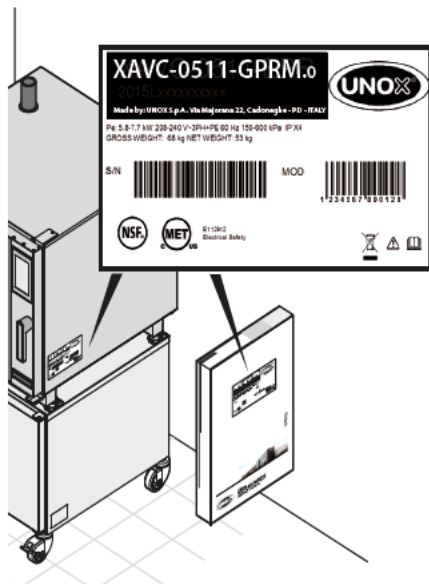

the ground connection.

③ Make sure there is electrical continuity between the outer casing and the ground wire.

④ Determine the correct wire size and circuit breaker using the reference chart.

**!** The oven is not supplied with the electrical supply cable. The electrical supply cable must be fabricated with the appropriate wire size, to meet all codes and requirements per the electrical requirements specified on the oven label.

**!** The wiring diagrams, the wire specifications and the technical data are indicated on the “Technical specifications ” sheet attached to the appliance. Three-Phase Cable Attached to a Terminal Board

- ① Select the proper cable.
- ② Open the lower part of the back panel.
- ③ Route the power supply cable through the cable clamp.
- ④ Remove the screws holding the control panel components.
- ⑤ Connect the wires to the correct terminals. Place the copper jumper and cable underneath the screw in its tightening direction, so when the screw is tightened, the cable and jumper are tightly secured to the terminal. Connect the ground wire to the ground terminal.
- ⑥ Secure the cable using the cable clamp.
- ⑦ Close the terminal board cover and tighten the attaching screws.
- ⑧ Also, provide a means for disconnecting the power for maintenance or repair.

## 6 GAS CONNECTIONS

**⚠ WARNING** Read and follow ALL safety instructions on page 2 and **Installation codes and standards** on page 14.

**⚠ WARNING** The installation must conform with local codes, or in the absence of local codes, with the National Fuel Gas Code, ANSI Z223.1/ NFPA 54, or the Natural Gas and Propane Installation Code, CSA B149.1, as applicable, including:

1. The appliance and its individual shutoff valve must be disconnected from the gas supply piping system during any pressure testing of that system at test pressures in excess of ½ psi (3.5 kPa).
2. The appliance must be isolated from the gas supply piping system by closing its individual manual shutoff valve during any pressure testing of the gas supply piping system at test pressures equal to or less than ½ psi (3.5 kPa).

### CONNECTING TO THE GAS UTILITY SYSTEM

The appliance is factory set, configured and tested to operate using:

- natural gas (G20)
- nominal pressure of the mains supply (entering the gas valve) of 5-35mbar (5kPa-35kPa)
- maximum gas inlet pressure of 40 mbar (5.5kPa).
- maximum pressure drop at ignition = 5mbar.

Before connection, check that the available gas and pressure comply with the information above: this information is also shown on the "DATA PLATE GAS" plate attached to the side of the oven.

The mains pressure entering the valve should never exceed 55 Mbar (5.5kPa).

The female attachment for connection to the gas utilities is on the lower part of the oven: the connection must be done using a rigid or flexible pipe with a cut-off valve (not supplied) placed upstream of the appliance.

- ⚠ Make sure that the piping does not run next to hot areas and that they are not subject to pulling, twisting or crushing forces.
- ⚠ The gas supply system and all attachments must be up to code and respect the regulations in force in the country of use.
- ⚠ Components sealed with red paint must never be adjusted!
- ⚠ Unox provides upon customer request an adapter whose diameter varies in relation to oven model to connect the evacuation switch to the wind deflector device.

! For all the appliance equipped with casters the installation shall be made with a connector that complies with the Standard for Connectors for Movable Gas Appliances, ANSI Z21.69 • CSA 6.16, and a quick-disconnect device that complies with the Standard for Quick-Disconnect Devices for Use With Gas Fuel, ANSI Z21.41 • CSA 6.9. To limit the movement of the appliance without depending on the connector and the quick-disconnect device the appliance must be fixed to the rear walls by using Unox chains kit supplied with the appliance (see par. **Checking package contents** on page 18). The instruction to fix the ovens by chains are shown on page 28.

! When the appliance is supplied on casters and is connected to the supply piping by means of a connector for movable appliances, the operator must be aware that there is a restraint on the appliance and, if disconnection of the restraint is necessary, to reconnect this restraint after the appliance has been returned to its originally installed position.

! Special adjustments are not needed when using this appliance at high altitudes.

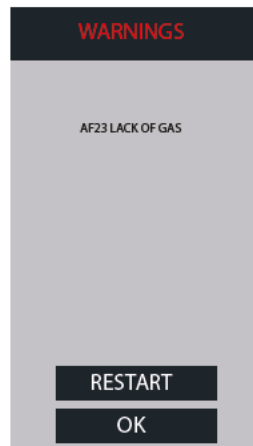
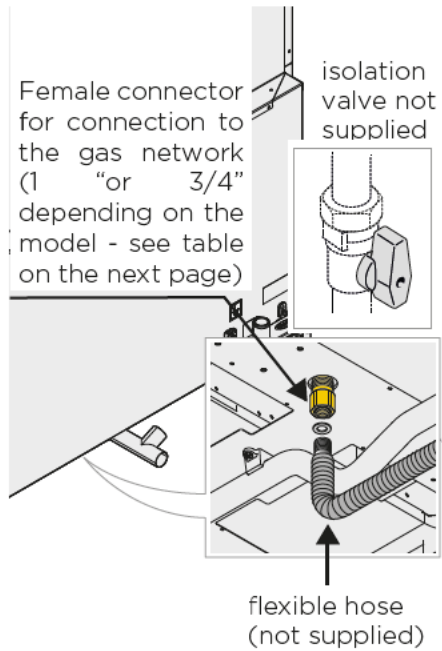

## ADAPTING TO DIFFERENT GAS SUPPLIES

**⚠ WARNING** Operations to adapt the oven to another type of gas must be exclusively performed by qualified personnel authorised by UNOX. The appliance is equipped with orifices sized for operation with Natural Gas.

For the conversion of the oven for the use of another type of gas (LP-Gas), remove the valve as shown in the figure and insert the orifice.

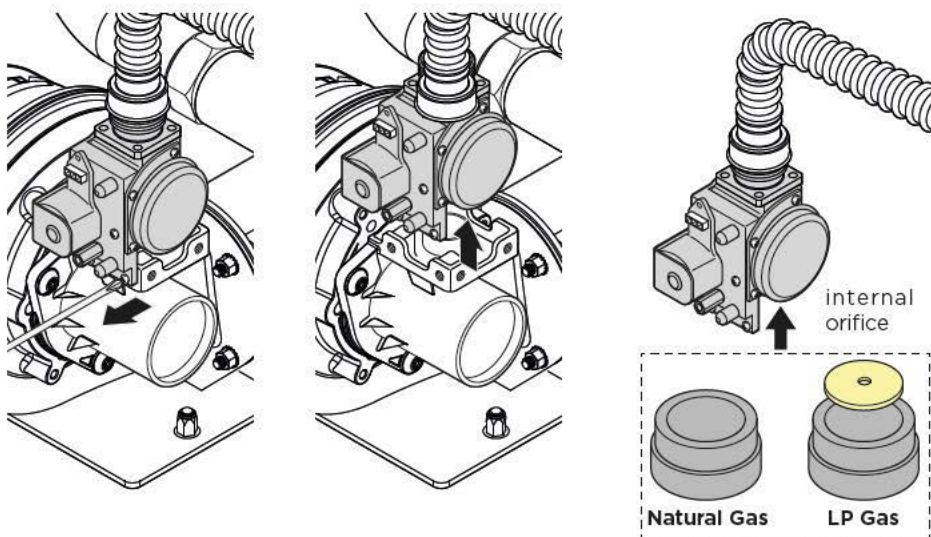

mixed air-gas to  
the burner

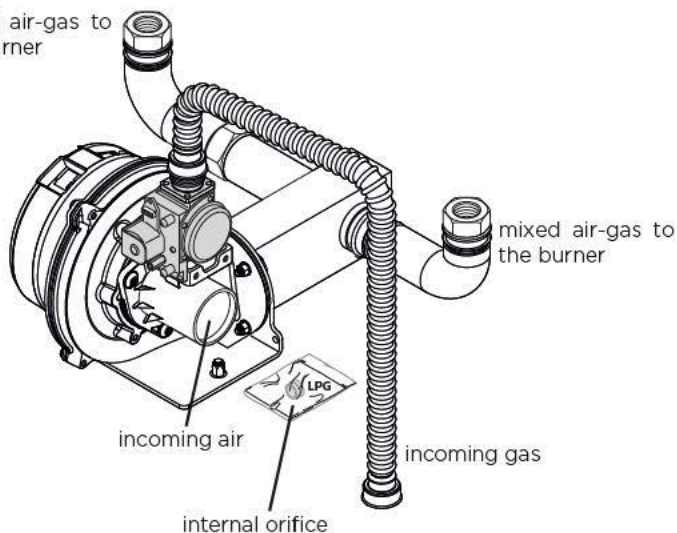

CHEFTOP MIND.Maps™ PLUS							
Oven models	Gas connection	P max [kW]		P start [kW]		P min [kW]	
		NG	LPG	NG	LPG	NG	LPG
XAVC-0511-GP*	3/4"	15	15	11	13	7	7
XAVC-1011-GP*	3/4"	22	22	17	17	7,5	7,5
XAVC-06FS-GP*	3/4"	24	24	16	16	8,5	8,5
XAVC-10FS-GP*	3/4"	35	35	21	23	11	11
XAVC-16FS-GP*	3/4"	70	70	50	50	23	23
XAVL-2021-GP*S	1"	90	90	50	55	25	25
XAVL-2021-NP*S	1"	90	90	50	55	25	25

CHEFTOP MIND.Maps™ PLUS				
Oven models	Max gas consumption [m³/h]		Max gas consumption [kg/h]	
	NG	LPG	NG	LPG
XAVC-0511-GP*	1,4229328	0,429219		1,077661
XAVC-1011-GP*	2,096347	0,629521		1,580569
XAVC-06FS-GP*	2,286924	0,68675		1,724257
XAVC-10FS-GP*	3,335098	1,00151		2,514542
XAVC-16FS-GP*	6,670196	2,00302		5,029084
XAVL-2021-GP*S	8,575966	2,575312		6,465965
XAVL-2021-NP*S	8,575966	2,575312		6,465965

## PLUMBING CONNECTIONS

### SPECIFIC WATER/DRAIN CONNECTION

A backflow protection device may be required by local codes. If so, install on the potable water system directly ahead of the appliance. The backflow protection device shall be any of the following: an approved pressure type vacuum breaker installed at least 12" above the highest point of use, a double check valve backflow preventer or a reduced pressure principal backflow preventer.

 The new hose-sets supplied with the appliance are to be used and that old hose-sets should not be reused.

### PLUMBING: WATER INLET CONNECTION

Water inlet connection includes:

- 59" (1.5 m) of hose, mechanical filter, pressure reducer and (3/4") fitting with non-return valve for plumbing;
- two attachments for connecting additional water treatment accessories (**UNOX.Finest**);
- a pipe to supply detergent to clean the oven cavity;

Follow instruction on the accessory package for connection. Do not use resin ion exchange water softeners.

 To simplify plumbing in cases of multiple column connections (**MAXI.Link**) use the Tee in the UNOX oven stacking kit.

### INLET WATER CHARACTERISTICS

Inlet water must have the following specifications:

- have a maximum temperature of 86 °F (30 °C);
- be drinkable;
- be pressured at between 22 and 87 psi (150-600 kPa).

 If water pressure at the inlet is less than the minimum specified value (22 psi - 1.50 bar) a pump (minimum water flow rate 1.32 gpm (300 l/h) is required. The ovens have a built-in pressure reducer.

If water conductivity is greater than 150 µS/cm a water treatment for steam production is required.

Damage caused by limescale or other chemical agents is not covered by the warranty.

** WARNING CHLORAMINE: The water supplied to the oven must be free from chloramine or with levels not exceeding 0,1 ppm (mg/L). Notice: any damage caused by chloramine within the water is not covered by this warranty.**

## Water specifications for the STEAM circuit (steam inside the oven cavity)

Free chlorine  $\leq 0.1$  ppm, Chloramines  $\leq 0.1$  ppm (mg/L)

TDS  $\leq 125$  ppm, Silica  $\leq 12$  ppm, pH 7 to 8.5, Total hardness (TH)  $\leq 8$  °d

Chlorides  $\leq 25$  ppm, Alkalinity  $\leq 150$  ppm as  $\text{CaCO}_3$

\* The maximum chloride content,  $\text{Cl}^-$ , is not a fixed value; it depends on the calculated Non Hardness Measurement (NHM)

### NHM = EC - (TH\*\* x 30)

EC = electrical conductivity [ $\mu\text{S}/\text{cm}$ ]

TH = total hardness\*\* [ $^\circ \text{dH}$  - German degrees]

NHM $\leq 250$ $\mu\text{S}/\text{cm}$	TH < 8 °dH, $\text{Cl}^- \leq 25$ ppm (5 drops of reagent*)	No water treatment
	TH $\geq 8$ °dH, $\text{Cl}^- \leq 25$ ppm (5 drops of reagent*)	UNOX.Finest
	$\text{Cl}^- > 25$ ppm (5 drops of reagent*)	Reverse Osmosi System
NHM = 250 - 350 $\mu\text{S}/\text{cm}$	$\text{Cl}^- \leq 20$ ppm (4 drops of reagent*)	UNOX.Finest
	$\text{Cl}^- > 20$ ppm (4 drops of reagent*)	Reverse Osmosi System
NHM = 350 - 450 $\mu\text{S}/\text{cm}$	$\text{Cl}^- \leq 15$ ppm (3 drops of reagent*)	UNOX.Finest
	$\text{Cl}^- > 15$ ppm (3 drops of reagent*)	Reverse Osmosi System
NHM = 450 - 500 $\mu\text{S}/\text{cm}$	$\text{Cl}^- \leq 10$ ppm (2 drops of reagent*)	UNOX.Finest
	$\text{Cl}^- > 10$ ppm (2 drops of reagent*)	Reverse Osmosi System
NHM $\geq 500$ $\mu\text{S}/\text{cm}$		Reverse Osmosi System

\* use the reagent in the UNOX [KSTR1081A](#) kit

\*\* hardness measured using the UNOX [KSTR1082A](#) kit

## Inflow water specifications WASHING circuit:

Free chlorine  $\leq 0,1$  ppm

Chloramine  $\leq 0,1$  ppm

TDS  $\leq 125$  ppm

Silica  $\leq 12$  ppm

pH 7 ÷ 8,5

Total hardness (TH)  $\leq 20^\circ\text{d}$

Chlorides  $\leq 80$  ppm

Alkalinity  $\leq 250$  ppm as  $\text{CaCO}_3$

Should the water values for the WASH circuit or for moisture generation different from those shown, use a filter (**UNOX.Finest**).

For a total water hardness exceeding 25 dH, an ion exchange resin treatment is required upstream from the osmosis. However, do not use a  $\text{Na}^+$  ion exchange resin if water conductivity exceeds 450  $\mu\text{S}/\text{cm}$  because it may cause glass corrosion.

⊕ If the pressure of the water supply at the inlet is too low (150kPa), a pump with a suitable flow rate should be used (minimum flow rate of 300 l/h). The **CHEFTOP MIND.Maps™** ovens come with an integrated pressure reducer.

If the water conductivity is greater than the value indicated (150  $\mu\text{S}/\text{cm}$ ), use a demineralizer or filters (**UNOX.Finest**) to avoid lime scale and/or other minerals from depositing inside the oven. Damage caused by lime scale or other chemical agents carried by the water is not covered by the guarantee. UNOX recommends using its "**UNOX.Finest**" filters. If the hardness exceeds 10°dH and chlorides have a concentration lower than 25ppm, **UNOX.Finest** filters must be used. Follow the instructions on the packaging of these parts for their assembly/disassembly.

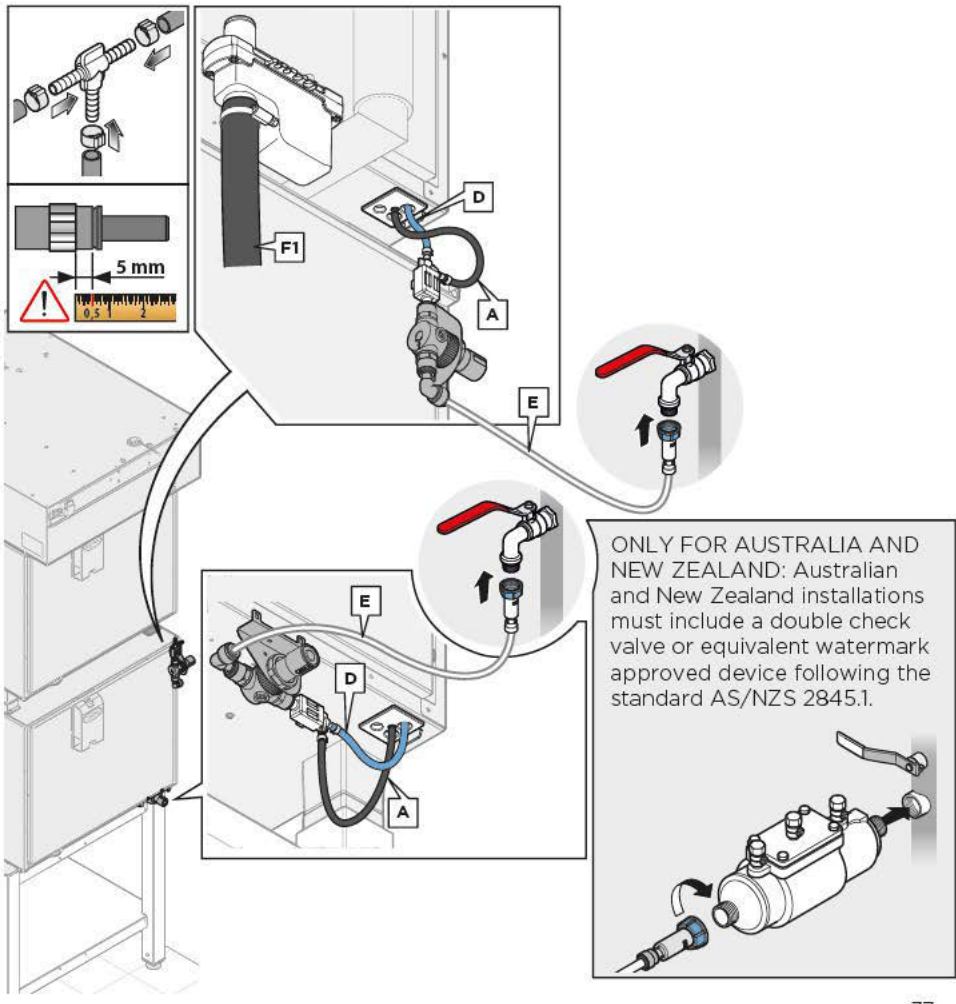

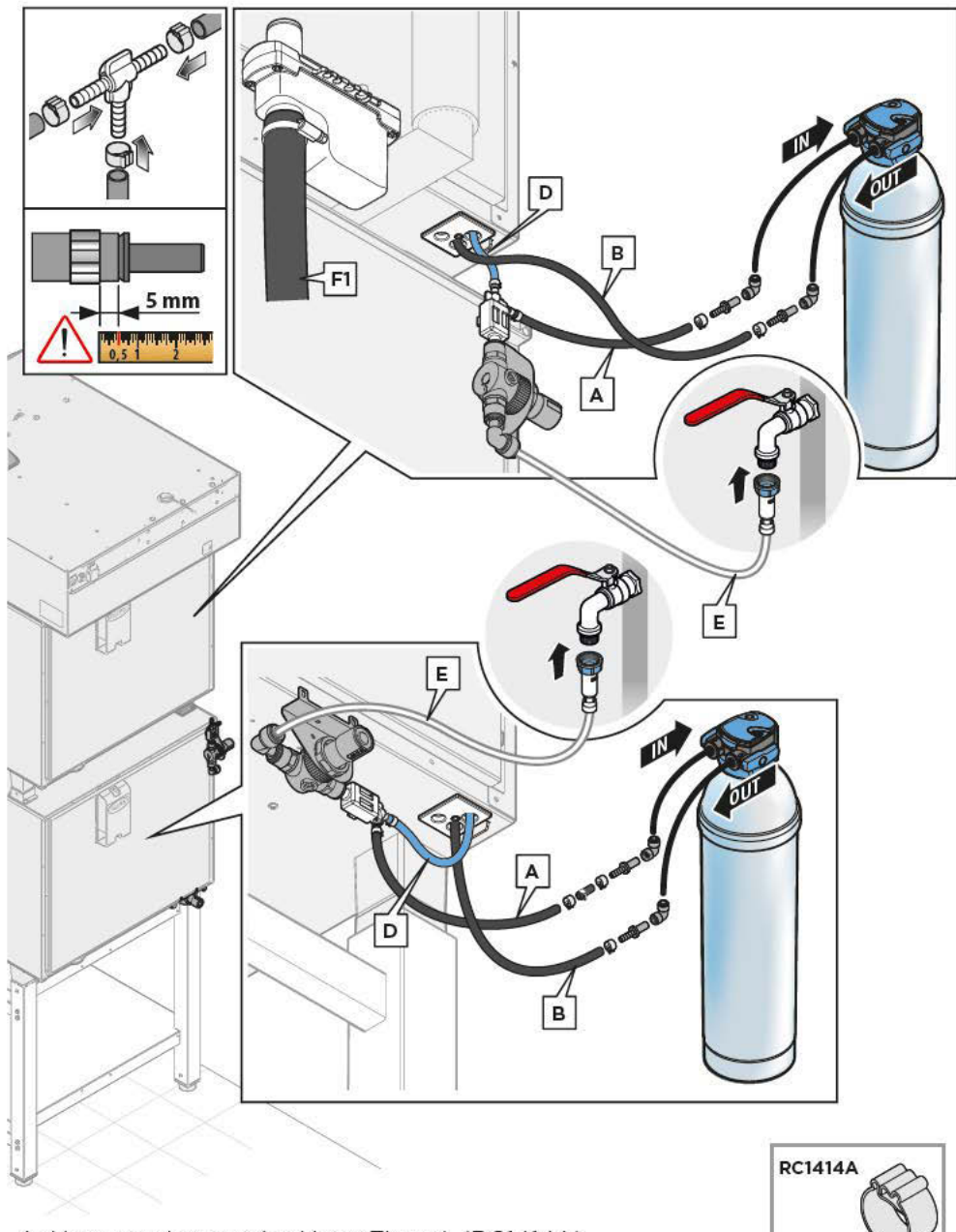

- A: Untreated water (to Unox.Finest) (RC1414A)
- B: Treated water (from Unox.Finest) (RC1414A)
- C: Connection to the detergent tank (RC1019A)
- D: Cleaning water (untreated) (RC1414A)
- E: Incoming water (RC1414A)

RC1414A



RC1019A

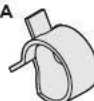

## PLUMBING: WATER DRAINAGE

The wastewater drain is located:

- on the bottom of counter top ovens;
- on the back of free-standing ovens with or without trolley.

Connect the U-trap to a flexible hose and connect the unit to waste water drainage in accordance with local water regulations.

**+** Unox recommends its proprietary rigid pipes and flexible hoses.

**!** **The waste water draining from the oven may be hot (194 °F - 90 °C). The pipes used for water drainage must be able to withstand high temperatures and not be made of metal.**

## Drainage specifications

The wastewater connection must include:

- an U-trap;
- a drainpipe minimum 11 3/4" (30 cm) and maximum 3 7/8" (100 cm) long;
- a drainpipe laid with a constant fall of minimum 4%.
- Units have a 1 1/8" (30 mm) in diameter discharge pipe and are supplied without drainpipes.
- Only floor-standing ovens are supplied with an U-trap.

The wall-mounted exhaust output must have an air gap of at least 1" (25 mm).

FREE-STANDING OVENS  
WITH OR WITHOUT TROLLEY <sup>(1)</sup>

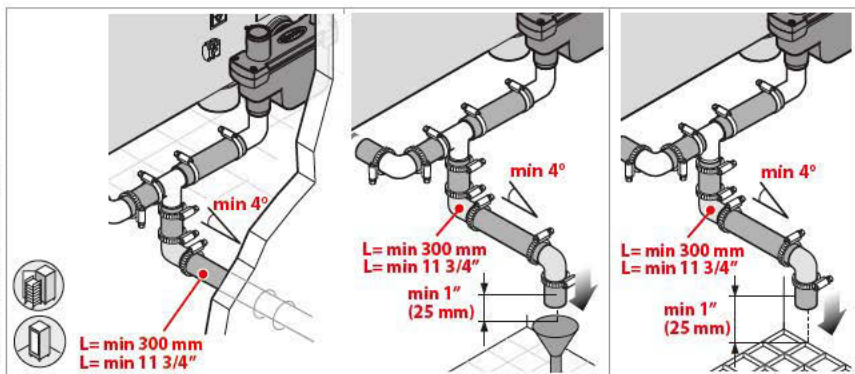

COUNTERTOP OVENS

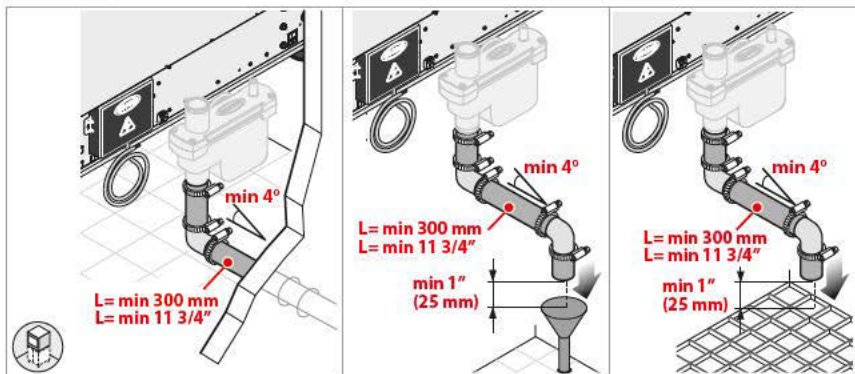

USA

## SIPHON FILLING

After installation, pour at least 0.5 l (0.132 gal) in the drain in the oven cooking chamber until the siphon is filled.

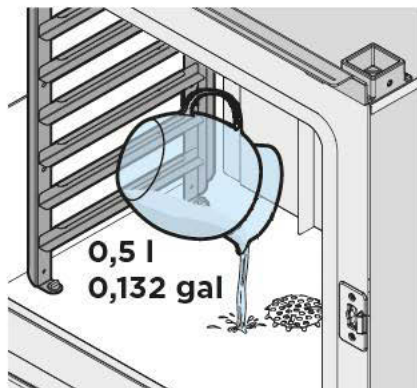

## 8

## FILLING THE DETERGENT TANK

- ! Filling can only be done with the 1-litre bottles of the **UNOX.Det&Rinse** detergent.

To refill the detergent:

1. Wear gloves to avoid direct contact of hands with detergent.
2. Take out the tank from under the oven until you hear a “click”.
3. Open the lid of the tank.
4. Open the cap of the UNOX 1-litre detergent bottle **without removing/piercing the protective film!**
5. Turn the bottle upside down and screw it on the tank (by screwing the bottle, a pin in the tank breaks the protective film, which allows the detergent to come out).

- ! **The detergent must not come into contact with the skin, eyes or mucous membranes.** In case of contact with the detergent, follow the instructions found on the safety data sheet.

7. Repeat the process up to the maximum level allowed indicated on the front of the tank. (Maximum capacity of the tank is 4 litres = 4 bottles)
8. Remove the bottle.
9. Replace the tank under the oven until it stops.
10. Dispose of the gloves, taking care not to touch the areas spoiled with detergent.



Never touch the detergent with bare hands!



When the end is closed with the plug DO NOT use the wash cycle or wash the chamber with large amounts of water as this could cause flooding.



Periodically check the presence of rust stains inside the oven chamber: if they are found, contact a Service Centre urgently because the water is probably damaging the oven; prompt action will extend the lifespan of the equipment.

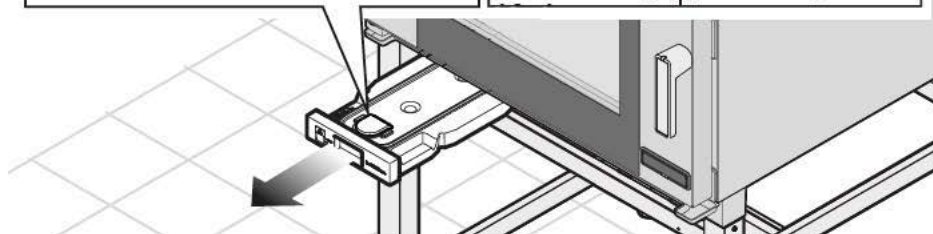
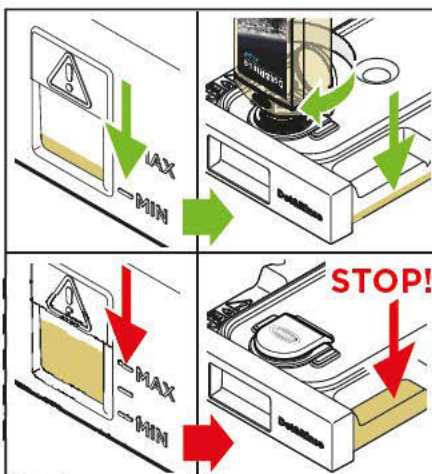
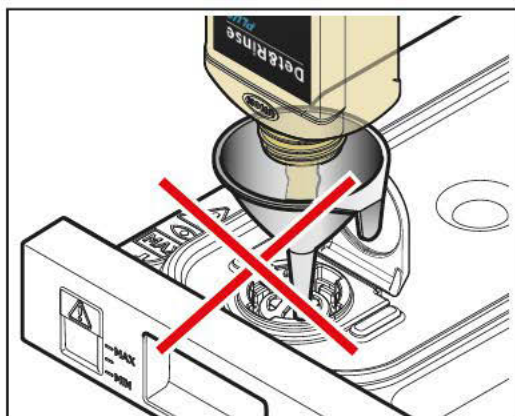

**DO NOT TAMPER WITH THE TANK AND ITS CONNECTIONS TO THE OVEN FOR ANY REASON AS THIS COULD CAUSE A RISK OF INJURY OR DEATH**

## 9 SMOKE EXHAUST

**⚠ WARNING** Injury risk! Read and follow all the safety instructions in the Safety section of this manual. Follow the Installation codes and standards referenced in this manual.

An exhaust pipe evacuates smoke and odours from the oven cavity as well as the exhaust gases. According to the appliance, evacuation can be done:

### ① By an efficient natural ventilation flue.

The ventilation flue must:

- have the same diameter ( $\varnothing D$ ) throughout the entire length of the oven's exhaust pipe connection;
- have an upright section ( $3\varnothing D$ ) above the ventilation elbow that is 3 times the diameter  $\varnothing D$ ;
- follow an upward trajectory at a minimum incline of 10%, and must incorporate no angles smaller than 90 degrees. The horizontal part (L) must not exceed 59" 1/16 (1.5 metres) in length.

**+** We recommend a flue cover

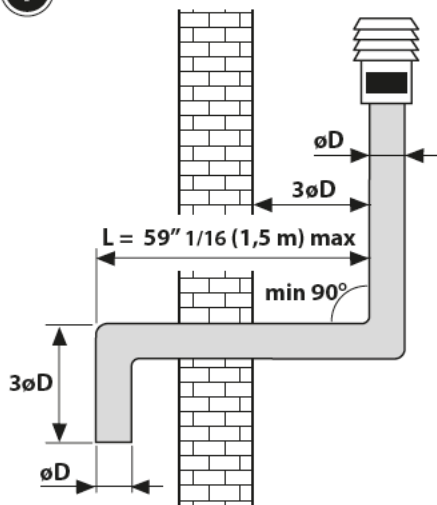

be installed on top of the external end of the flue, to prevent rainwater from getting into the oven and to minimise pressure drops caused by the Venturi effect, which can occur during strong air currents.

### ② By a ventilation hood

The hood must be installed at least 19" 11/16 (50 cm) from the exhaust pipe: smaller distances could cause toxic unburnt gas to form.



Make sure that no objects or materials that may obstruct fume evacuation or become damaged by the temperature or fumes are placed above the smoke exhaust. Do not leave flammable materials near the smoke exhausts.

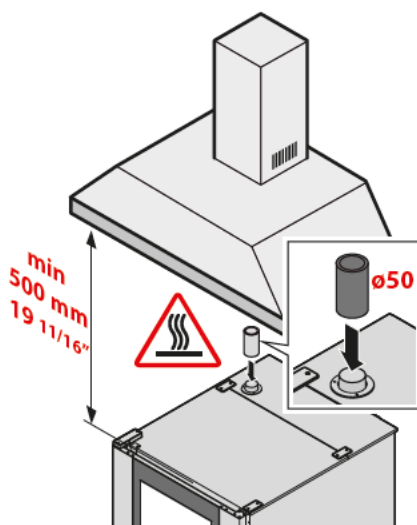

## 10 OVEN RESETTING PROCEDURE

(reserved for Service calls)

To restore the functionality of the oven, remove the black cap of the thermostat by unscrewing it and press the red pin as shown in the figure (reserved for Service calls).

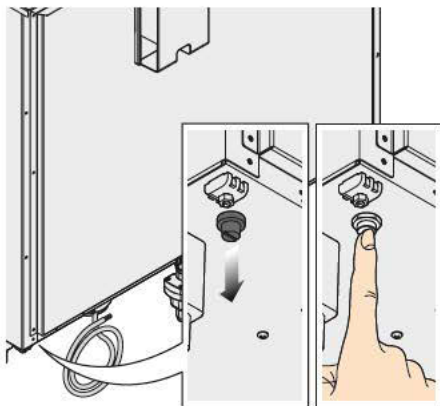

## 11 CONNECTING STACKED APPLIANCES (MAXI.Link)

All ovens of the **CHEFTOP-MIND. Maps™** line are designed to be connected to accessories (prover, hood, etc.). The accessories connect to the oven by means of ModBus connectors located on the back of the oven, which automatically connect.

- 1 Disconnect all appliance from the electricity mains.
- 2 Remove the rear panel of the oven to access the power board.
- 3 Connect the RJ45 cable to one of the ModBus outlets corresponding to the power board.
- 4 Replace the rear panel of the ovens.
- 5 Reconnect all the appliances to the electricity mains.

**+** Follow the instructions contained in the accessory packing for information on how to fully install and manage them.

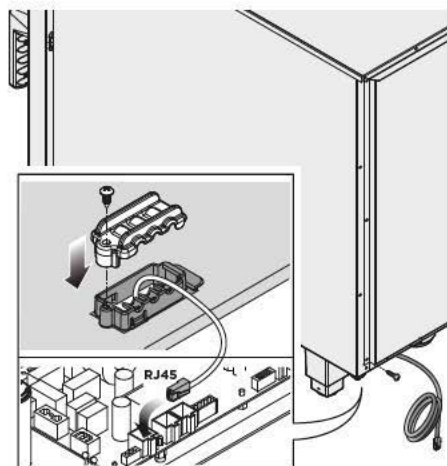

**!** Connect the ModBus cables only to the relative ModBus connectors and not to the RJ45 Ethernet connectors.

# UNOX LIMITED WARRANTY CONDITIONS - US

End users (“**End Users**”) who have purchased an appliance (the “**Product**”) from an authorized dealer of Unox, Inc., a Delaware corporation (“**UNOX**”) may be entitled to a limited manufacturer’s warranty (the “**Limited Warranty**”). In order to benefit from such a warranty, End User should register on UNOX’s website ([www.unox.com](http://www.unox.com)).

## 1. Warranty Term

- a) The warranty period for the Limited Warranty (the “**Warranty Term**”) is, with respect to labor, 12 months, and with respect to the Product or parts thereof (such parts being hereinafter referred to as “**Spare Parts**”), 24 months, in each case from the earlier of (i) the date of End User’s dealer invoice and (ii) the date of installation of the Product at the End User’s location (the “**Warranty Start Date**”); provided, however, that upon failure from End User to provide UNOX, upon request, with supporting evidence reasonably satisfactory to UNOX of such End User’s dealer invoice or installation date, as shall be determined by UNOX in its sole discretion, then the Warranty Start Date may, at UNOX’s sole discretion, be the date of UNOX’s invoice to its own dealer.
- b) For ChefTop Mind.Maps™ ovens only, and only if End User has purchased or otherwise has been provided with a LONG.LIFE4 extended warranty (the “**Extended Warranty**”), then the Warranty Term is, with respect to labor, 12 months from the Warranty Start Date, and with respect to the Product and/or Spare Parts, the earlier of (i) 48 months from the Warranty Start Date, and (ii) ten thousand (10,000) hours of working and/or stand-by time of such Product, as determined by the Product’s internal clock. The foregoing Extended Warranty is available to End User if and only if the applicable Product is connected to the internet via Ethernet cable, WIFI or 3G/4G and remains accessible for remote login and maintenance by the UNOX service team at all times.

**2.** If End User decides not to buy the Extended Warranty, in order for the Limited Warranty to apply, End User will need to furnish UNOX a copy of End User’s dealer invoice and sufficient proof (as determined by UNOX in its sole discretion) of the installation date and the type of Product in the form of a written confirmation or an invoice for installation issued by a Service Agent.

## 3.

- a) For Products subject to the Limited Warranty, during the applicable Warranty Term, and if and only if such Product is unaltered and unmodified by End User or any third party and is properly used as set forth in UNOX’s specifications and instructions of use, End User’s sole remedy under the Limited Warranty shall be (x) for a period of twelve (12) months after the Warranty Start Date, at UNOX’s sole cost and expense and in UNOX’s sole discretion, (i) repair, or (ii) return and replacement (including, in each of the foregoing cases (i) and (ii), any cost of UNOX’s or its designee’s work associated therewith), of the Product (including any Spare Parts), and (y) for a period of twelve (12) months after the initial twelve (12) months following the Warranty Start Date, at UNOX’s sole cost and expense, replacement of the Products and/or Spare Parts, excluding any work associated therewith.
- b) For Products subject to the Extended Warranty, during the applicable Warranty Term, and if and only if such Product is unaltered and unmodified by End User or any third party and is properly used as set forth in UNOX’s specifications and instructions of use, End User’s sole remedy under the Extended Warranty

shall be (x) for a period of twelve (12) months after the Warranty Start Date, at UNOX's sole cost and expense and in UNOX's sole discretion, (i) repair, or (ii) return and replacement (including, in each of the foregoing cases (i) and (ii), any cost of UNOX's or its designee's work associated therewith), of the Product (including any Spare Parts), and (y) for a period which shall be the shorter of (A) thirty-six (36) months after the initial twelve (12) months following the Warranty Start Date, and (B) ten thousand (10,000) hours of working and/or stand-by time of such Product has been reached, if earlier, as determined by the Product's internal clock, at UNOX's sole cost and expense, replacement of the Product and/or Spare Parts only, excluding any work associated therewith.

The warranty services set forth above shall be referred to herein as "**Warranty Services**", as applicable. Except as provided above, the Products are provided "as is".

**4.** The performance of **Warranty Services** shall in no event trigger an extension of a Warranty Term, nor shall it trigger a new Warranty Term.

**5.** Replaced parts shall pass into the ownership of UNOX.

**6.** UNOX does not assume any transport costs or risks.

**7.** In order to be eligible for the Warranty Services during the applicable Warranty Term, End User must notify UNOX in writing of any damage or defects within 14 days after such damage or defects were or should have been discovered by sending a notification to the UNOX service support, as provided on the UNOX website, [www.unox.com](http://www.unox.com).

**8.** Please be aware that neither the Limited Warranty nor the Extended Warranty shall apply in any of the following instances, without limitation, as determined in UNOX's sole discretion:

- Damage resulting from defective installation or unprofessional or improper attempts at repair, work performed by un-authorized third parties, improper use, injudicious operation or any and all other actions not in compliance with the instruction manual for the Product;
- Non-compliance, by End User or any third party, with the UNOX installation check list, the installation manual, or the prescribed maintenance and inspection cycles;
- If cleaning agents or preservative agents other than those expressly approved by UNOX have been used;
- Defects or damage in connection with unauthorized uses of the Product, such as the use of soiled, aggressive water, sub-standard gas or electricity with unsuitable voltage or current;
- Damage caused by surges;
- Normal wear and tear to items such as lamps, gaskets, seals, probes, door handles, ancillary and consumable parts etc ., as well as damage to glassware and other ancillary parts
- The use of water not meeting requirements set forth by UNOX in the installation manual and spec sheet (for the avoidance of doubt, in addition, but without limitation, to the foregoing, it is the sole responsibility of the End User to verify that the incoming water supply is comprehensively tested and, if required, to provide a means of water treatment that would meet the minimum water

quality standards required by UNOX, as outlined on the Product specification sheet. Non-compliance with these minimum standards will potentially damage Products and/or Spare Parts, which, at UNOX's sole discretion, may nullify and void the original Limited Warranty or Extended Warranty, as applicable);

- Damage or malfunctions caused by the build-up of limescale or rust in the Product;
- Wear and tear of the Product; or
- Cases in which replacement or parts other than original UNOX parts are used, regardless of whether the damage or defects result therefrom.

**14.** The Limited Warranty and the Extended Warranty may only be asserted for Products located in the United States of America.

**15.** An obligation to render Warranty Services shall only exist if the Product is in compliance with the applicable technical requirements in the country in which the Product is operated.

**16. NO OTHER WARRANTIES.** EXCEPT AS SET FORTH IN THE INTRODUCTION HERETO, THE PRODUCTS ARE PROVIDED "AS IS", AND THE LIMITED WARRANTY AND EXTENDED WARRANTY ARE GIVEN IN LIEU OF ALL OTHER WARRANTIES AND GUARANTIES, EITHER EXPRESS OR IMPLIED, INCLUDING, WITHOUT LIMITATION, THE WARRANTY OF MERCHANTABILITY OR FITNESS FOR A PARTICULAR USE (EVEN IF INFORMED OF SUCH USE), OR ARISING FROM A COURSE OF DEALING, USAGE, OR TRADE PRACTICE, WHICH ARE HEREBY EXCLUDED TO THE FULLEST EXTENT ALLOWED BY APPLICABLE LAW. NO WARRANTY HAS BEEN MADE THAT THE PRODUCTS WILL MEET END USER'S OR ITS CUSTOMER'S REQUIREMENTS, OR THAT THE OPERATION OF THE PRODUCTS WILL BE UNINTERRUPTED OR ERROR-FREE.

PLEASE CONTACT UNOX AT [infousa@unox.com](mailto:infousa@unox.com) IF YOU HAVE ANY QUESTIONS.



**UNOX INC.**  
105 TERRY DRIVE, SUITE 119  
NEWTOWN, PENNSYLVANIA 18940  
1-800-489-UNOX  
Infousa@unox.com

**INTERNATIONAL**

**UNOX S.p.A.**  
Via Majorana 22 / 35010 Cadoneghe (PD) Italy  
Tel +39 049 8657511 / Fax +39 049 8657555  
Info@unox.com



INVENTIVE SIMPLIFICATION

**EUROPE**

**ITALIA**  
**UNOX S.p.A.**  
E-mail: info@unox.it  
Tel.: +39 049 86 57 511

**ČESKÁ REPUBLIKA**  
**UNOX DISTRIBUTION s.r.o.**  
E-mail: info.cz@unox.com  
Tel.: +420 241 940 000

**РОССИЯ, ПРИБАЛТИКА И СТРАНЫ СНГ**  
**UNOX РОССИЯ**  
E-mail: info.ru@unox.com  
Tel.: +7 (499) 702-00-14

**ESPAÑA**  
**UNOX PROFESIONAL ESPAÑA S.L.**  
E-mail: info.es@unox.com  
Tel.: +34 900 82 89 43

**SCANDINAVIAN COUNTRIES**  
**UNOX SCANDINAVIA AB**  
E-mail: info.se@unox.com  
Tel.: +46 (0)768 716 422

**UNITED KINGDOM**  
**UNOX UK Ltd.**  
E-mail: info@unoxuk.com  
Tel.: +44 1252 851 522

**PORTUGAL**  
**UNOX PORTUGAL**  
E-mail: info.pt@unox.com  
Tel.: +351 918 228 787

**DEUTSCHLAND**  
**UNOX DEUTSCHLAND GmbH**  
E-mail: info.de@unox.com  
Tel.: +49 2951 98760

**FRANCE, BELGIUM & LUXEMBOURG**  
**UNOX FRANCE S.a.s.**  
E-mail: infofr@unox.com  
Tel.: +33 4 78 17 35 39

**ÖSTERREICH**  
**UNOX ÖSTERREICH GmbH**  
E-mail: bestellung@unox.com  
Tel.: +43 800 880 963

**HRVATSKA**  
**UNOX CROATIA**  
E-mail: narudzbe@unox.com  
Tel.: +39 049 86 57 538

**TÜRKİYE**  
**UNOX TURKEY Profesyonel MutfaK Ekip-  
manları Endüstri ve Ticaret Limited Şirketi**  
E-mail: info.tr@unox.com  
Tel.: +90 530 176 62 03

**IRELAND**  
**UNOX IRELAND**  
E-mail: info.ie@unox.com  
Tel.: +353 (0) 87 32 23 218

**БЪЛГАРИЯ**  
**UNOX BULGARIA**  
E-mail: info.bg@unox.com  
Tel.: +359 88 23 13 378

**ASIA & AFRICA**

**MALAYSIA & SINGAPORE**  
**UNOX (ASIA) SDN. BHD**  
E-mail: info.asia@unox.com  
Tel.: +603-58797700

**OTHER ASIAN COUNTRIES**  
**UNOX (ASIA) SDN. BHD**  
E-mail: info.asia@unox.com  
Tel.: +603-58797700

**PHILIPPINES**  
**UNOX PHILIPPINES**  
E-mail: info.asia@unox.com  
Tel.: +63 9173108084

**대한민국**  
**UNOX KOREA CO. Ltd.**  
이메일: info.asia@unox.com  
전화: +82 2 69410351

**AMERICA & OCEANIA**

**U.S.A. & CANADA**  
**UNOX Inc.**  
E-mail: Infousa@unox.com  
Tel.: +1 800 489 8669

**MEXICO**  
**UNOX MEXICO, S. DE R.L. DE C.V.**  
E-mail: info.mx@unox.com  
Tel.: +52 1555 4314 180

**BRAZIL**  
**UNOX BRAZIL**  
E-mail: info.br@unox.com  
Tel.: +55 11 98717-8201

**U.A.E.**  
**UNOX MIDDLE EAST DMCC**  
E-mail: info.uae@unox.com  
Tel.: +971 52 304 3321

**SOUTH AFRICA**  
**UNOX SOUTH AFRICA**  
E-mail: info.sa@unox.com  
Tel.: +27 845 05 52 35

**INDONESIA**  
**UNOX INDONESIA**  
E-mail: info.asia@unox.com  
Tel.: +62 81908852999

**中华人民共和国**  
**UNOX TRADING (SHANGHAI) CO. Ltd.**  
电子邮件: info.china@unox.com  
电话: +86 21 56907696

**COLOMBIA**  
**UNOX COLOMBIA**  
E-mail: info.co@unox.com  
Tel.: +57 350 65 88 204

**AUSTRALIA**  
**UNOX AUSTRALIA PTY Ltd.**  
E-mail: info@unoxaustralia.com.au  
Tel.: +61 3 9876 0803

**NEW ZEALAND**  
**UNOX NEW ZEALAND Ltd.**  
E-mail: info@unox.co.nz  
Tel.: +64 (0) 800 76 0803

LI2482B2.D00-LD1-01 - Printed: 01-2024  
All images used are for illustrative purposes only.  
All features indicated in this catalogue may be subject to change and could be updated without notice.

UNOX.COM | FOLLOW US ON

