

# Washer-Extractors

Pocket Hardmount

UniLinc and M30 Control

Refer to Page 9 for Model Identification



Installation/Operation/Maintenance

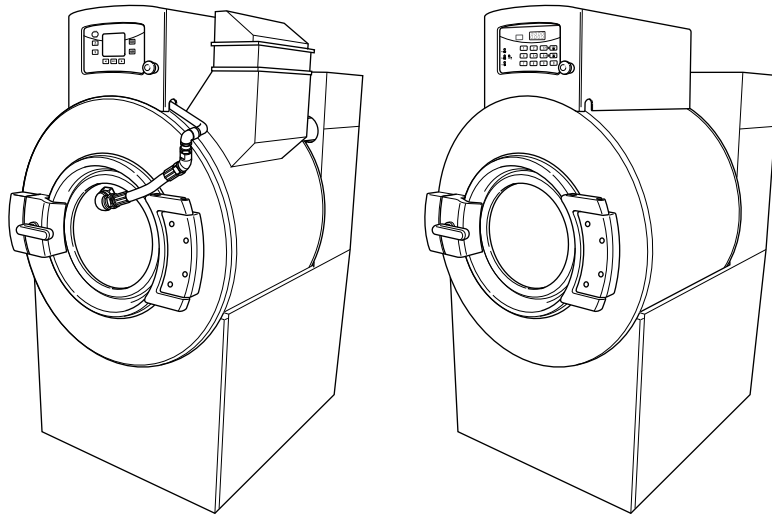

PHM1429C\_SVG

## Original Instructions

**Keep These Instructions for Future Reference.**

(If this machine changes ownership, this manual must accompany machine.)



[www.alliancelandry.com](http://www.alliancelandry.com)

Part No. F8410701ENR13  
May 2017



# Table of Contents

<b>Safety Information.....</b>	<b>5</b>
Explanation of Safety Messages.....	5
Important Safety Instructions.....	5
Safety Decals.....	7
Operator Safety.....	7
<b>Introduction.....</b>	<b>8</b>
Model Identification.....	8
Delivery Inspection.....	8
Serial Plate Location.....	8
Replacement Parts .....	9
Customer Service.....	9
Manufacturing Date.....	9
<b>Specifications and Dimensions.....</b>	<b>10</b>
Specifications and Dimensions.....	10
Machine Dimensions .....	13
Mounting Bolt Hole Locations - 45 and 65 Pound Models.....	16
Mounting Bolt Hole Locations - 85 and 105 Pound Models.....	18
Mounting Bolt Hole Locations - 130 and 160 Pound Models.....	20
Floor Layout.....	22
Mounting Bolt Pattern.....	25
Single Machine Foundation Requirements.....	25
Machine Installation on Existing Floor.....	26
Elevated Pad Installation on Existing Floor.....	27
New Foundation.....	27
Isolated Pad Installation.....	27
Machine Foundation and Pad Installation.....	28
Machine Installation.....	29
Machine Mounting and Grouting.....	32
Floor Load Data.....	35
Drain Connection Requirements.....	36
Water Connection.....	38
Plumbing Diagrams.....	41
Electrical Installation Requirements.....	44
North American Approval.....	46
CE Approval.....	53
Steam Requirements (Steam Heat Option Only).....	59
Chemical Injection Supply System.....	59
Connecting External Liquid Supplies with Five Compartment Supply Dispenser (Optional).....	62

External Supplies.....	63
Chemical Injection Using Internal 24VAC Control Transformer.....	64
Chemical Injection Using External AC Power Source.....	64
External Supply Signals.....	65
<b>Operation.....</b>	<b>67</b>
Operating Instructions for UniLine Control.....	67
Shakeout Routine.....	69
Basket Jog Feature (160 Pound Models Only).....	69
Operating Instructions for M30 Control.....	70
Shakeout Routine.....	72
<b>Start Up.....</b>	<b>73</b>
Basket Rotation.....	73
Safety Stability Switch Operation.....	73
<b>Maintenance.....</b>	<b>74</b>
Maintenance.....	74
Daily.....	74
Beginning of Day.....	74
End of Day.....	75
Monthly.....	75
Yearly.....	76
Care of Stainless Steel.....	77
<b>Disposal of Unit.....</b>	<b>79</b>
Disposal of Unit.....	79
<b>China Restriction of hazardous substances (RoHS).....</b>	<b>80</b>

# Safety Information

## Explanation of Safety Messages

Precautionary statements (“DANGER,” “WARNING,” and “CAUTION”), followed by specific instructions, are found in this manual and on machine decals. These precautions are intended for the personal safety of the operator, user, servicer, and those maintaining the machine.

	<b>DANGER</b>
Indicates an imminently hazardous situation that, if not avoided, will cause severe personal injury or death.	

	<b>WARNING</b>
Indicates a hazardous situation that, if not avoided, could cause severe personal injury or death.	

	<b>CAUTION</b>
Indicates a hazardous situation that, if not avoided, may cause minor or moderate personal injury or property damage.	

Additional precautionary statements (“IMPORTANT” and “NOTE”) are followed by specific instructions.

**IMPORTANT:** The word “IMPORTANT” is used to inform the reader of specific procedures where minor machine damage will occur if the procedure is not followed.

**NOTE:** The word “NOTE” is used to communicate installation, operation, maintenance or servicing information that is important but not hazard related.

## Important Safety Instructions

	<b>WARNING</b>
To reduce the risk of fire, electric shock, serious injury or death to persons when using your washer, follow these basic precautions:	
W023	

- Read all instructions before using the washer.
- Install the washer according the INSTALLATION instructions. Refer to the EARTH/GROUND instructions in the IN-

STALLATION manual for the proper earth/ground connection of the washer. All connections for water, drain, electrical power and earth/ground must comply with local codes and be made by licensed personnel when required. It is recommended that the machine be installed by qualified technicians.

- Do not install or store the washer where it will be exposed to water and/or weather.
- To prevent fire and explosion, keep the area around machine free from flammable and combustible products. Do not add the following substances or textiles containing traces of the following substances to the wash water: gasoline, kerosene, waxes, cooking oils, vegetable oils, machine oils, dry-cleaning solvents, flammable chemicals, thinners, or other flammable or explosive substances. These substances give off vapors that could ignite, explode or cause the fabric to catch fire by itself.
- Under certain conditions, hydrogen gas may be produced in a hot water system that has not been used for two weeks or more. HYDROGEN GAS IS EXPLOSIVE. If the hot water system has not been used for such a period, before using a washing machine or combination washer-dryer, turn on all hot water faucets and let the water flow from each for several minutes. This will release any accumulated hydrogen gas. The gas is flammable, do not smoke or use an open flame during this time.
- To reduce the risk of an electric shock or fire, DO NOT use an extension cord or an adapter to connect the washer to the electrical power source.
- Do not allow children to play on or in the washer. Close supervision of children is necessary when the washer is used near children. This appliance is not intended for use by young children or infirm persons without supervision. Young children should be supervised to ensure that they do not play with the appliance. This is a safety rule for all appliances.
- DO NOT reach and/or climb into the tub or onto the washer, ESPECIALLY if the wash drum is moving. This is an imminently hazardous situation that, if not avoided, will cause severe personal injury or death.
- Never operate the washer with any guards, panels and/or parts removed or broken. DO NOT bypass any safety devices or tamper with the controls.
- Use washer only for its intended purpose, washing textiles. Never wash machine parts or automotive parts in the machine. This could result in serious damage to the basket or tub.
- Use only low-sudsing, no-foaming types of commercial detergent. Be aware that hazardous chemicals may be present. Wear hand and eye protection when adding detergents and chemicals. Always read and follow manufacturer’s instructions on packages of laundry and cleaning aids. Heed all warnings or precautions. To reduce the risk of poisoning or

chemical burns, keep them out of the reach of children at all times [preferably in a locked cabinet].

- Do not use fabric softeners or products to eliminate static unless recommended by the manufacturer of the fabric softener or product.
- Always follow the fabric care instructions supplied by the textile manufacturer.
- Loading door **MUST BE CLOSED** any time the washer is to fill, tumble or spin. **DO NOT** bypass the loading door switch by permitting the washer to operate with the loading door open. Do not attempt to open the door until the washer has drained and all moving parts have stopped.
- The lid **MUST BE CLOSED** any time the washer is to spin. **DO NOT** bypass the lid release button by permitting the washer to operate with the lid open. Do not attempt to open the lid until the extract compartment has drained and all moving parts have stopped.
- Be aware that hot water is used to flush the supply dispenser, if applicable. Avoid opening the dispenser lid while the machine is running.
- Be aware that hot water is used to flush the supply dispenser. Avoid opening the dispenser lid while the machine is running.
- Do not attach anything to the supply dispenser’s nozzles, if applicable. The air gap must be maintained.
- Do not operate the machine without the water reuse plug or water reuse system in place, if applicable.
- Be sure water connections have a shut-off valve and that fill hose connections are tight. **CLOSE** the shut-off valves at the end of each wash day.
- Keep washer in good condition. Bumping or dropping the washer can damage safety features. If this occurs, have washer checked by a qualified service person.
- **DANGER:** Before inspecting or servicing machine, power supply must be turned **OFF**. The servicer needs to wait for at least 5 minutes after turning the power **OFF** and needs to check for residual voltage with a voltage meter. The inverter capacitor or EMC filter remains charged with high voltage for some time after powering **OFF**. This is an imminently hazardous situation that, if not avoided, will cause severe personal injury or death.
- Do not repair or replace any part of the washer, or attempt any servicing unless specifically recommended in the user-maintenance instructions or in published user-repair instructions that the user understands and has the skills to carry out. **ALWAYS** disconnect the washer from electrical, power and water supplies before attempting any service.
- Disconnect the power by turning off the circuit breaker or by unplugging the machine. Replace worn power cords.
- Before the washer is removed from service or discarded, remove the door to the washing compartment.
- Before the washer is removed from service or discarded, remove the lid to the washing compartment.
- Failure to install, maintain, and/or operate this washer according to the manufacturer’s instructions may result in conditions which can produce bodily injury and/or property damage.

**NOTE: The WARNINGS and IMPORTANT SAFETY INSTRUCTIONS appearing in this manual are not meant to cover all possible conditions and situations that may occur. Common sense, caution and care must be exercised when installing, maintaining, or operating the washer.**

Any problems or conditions not understood should be reported to the dealer, distributor, service agent or the manufacturer.

	<b>WARNING</b>
<p><b>Machine installations must comply with minimum specifications and requirements stated in the applicable Installation Manual, any applicable municipal building codes, water supply requirements, electrical wiring regulations and any other relevant statutory regulations. Due to varied requirements and applicable local codes, this machine must be installed, adjusted, and serviced by qualified maintenance personnel familiar with applicable local codes and the construction and operation of this type of machinery. They must also be familiar with the potential hazards involved. Failure to observe this warning may result in personal injury, property damage, and/or equipment damage, and will void the warranty.</b></p>	
W820	

**IMPORTANT: Ensure that the machine is installed on a level floor of sufficient strength. Ensure that the recommended clearances for inspection and maintenance are provided. Never allow the inspection and maintenance space to be blocked.**

	<b>WARNING</b>
<p><b>Never touch internal or external steam pipes, connections, or components. These surfaces can be extremely hot and will cause severe burns. The steam must be turned off and the pipe, connections, and components allowed to cool before the pipe can be touched.</b></p>	
SW014	

	<b>WARNING</b>
<p><b>Install the machine on a level floor of sufficient strength. Failure to do so may result in conditions which can produce serious injury, death and/or property damage.</b></p>	
W703	

## Safety Decals

Safety decals appear at crucial locations on the machine. Failure to maintain legible safety decals could result in injury to the operator or service technician.

Use manufacturer-authorized spare parts to avoid safety hazards.

## Operator Safety

	<b>WARNING</b>
<p><b>NEVER insert hands or objects into basket until it has completely stopped. Doing so could result in serious injury.</b></p>	
SW012	

The following maintenance checks must be performed daily:

1. Verify that all warning labels are present and legible, replace as necessary.
2. Check door interlock before starting operation of the machine:
  - a. Attempt to start the machine with the door open. The machine should not start.
  - b. Close the door without locking it and start the machine. The machine should not start.
  - c. Attempt to open the door while a cycle is in progress. The door should not open.

If the door lock and interlock are not functioning properly, disconnect power and call a service technician.

3. Do not attempt to operate the machine if any of the following conditions are present:
  - a. The door does not remain securely locked during the entire cycle.
  - b. Excessively high water level is evident.
  - c. Machine is not connected to a properly grounded circuit.

Do not bypass any safety devices in the machine.

	<b>WARNING</b>
<p><b>Operating the machine with severe out-of-balance loads could result in personal injury and serious equipment damage.</b></p>	
W728	

# Introduction

## Model Identification

Information in this manual is applicable to these models:



Models					
<b>45 Pound [20.4 Kg]</b>	UWH045K1L UWH045K1M UWH045K2L UWH045K2M UWH045T3V	UWH045T4V UWL045K1L UWL045K1M UWL045K2L UWL045K2M	UWL045T3V UWL045T4V UWN045K1L UWN045K1M UWN045K2L	UWN045K2M UWN045T3V UWN045T4V UWU045K1L UWU045K1M	UWU045K2L UWU045K2M UWU045T3V UWU045T4V
<b>65 Pound [29.5 Kg]</b>	UWH065K1L UWH065K1M UWH065K2L UWH065K2M UWH065T3L UWH065T3M UWH065T4L UWH065T3V	UWH065T4M UWH065T4V UWL065K1L UWL065K1M UWL065K2L UWL065K2M UWL065T3L UWL065T3M	UWL065T4L UWL065T3V UWL065T4M UWL065T4V UWN065T3L UWN065K1L UWN065K1M UWN065K2L	UWN065K2M UWN065T3M UWN065T3V UWN065T4L UWN065T4M UWN065T4V UWU065K1L UWU065K1M	UWU065K2L UWU065K2M UWU065T3L UWU065T3M UWU065T3V UWU065T4L UWU065T4M UWU065T4V
<b>85 Pound [38.6 Kg]</b>	UWH085K1M UWH085K2M UWH085T4V UWH085T3V	UWL085K1M UWL085K2M UWL085T4V UWL085T3V	UWN085K1M UWN085K2M UWN085T3V UWN085T4V	UWU085K1M UWU085K2M	UWU085T3V UWU085T4V
<b>105 Pound [47.6 Kg]</b>	UWH105K1M UWH105K2M UWH105T3V UWH105T4V	UWL105K1M UWL105K2M UWL105T3V UWL105T4V	UWN105K1M UWN105K2M UWN105T3V UWN105T4V	UWU105K1M UWU105K2M	UWU105T3V UWU105T4V
<b>130 Pound [59 Kg]</b>	UWH130K1M UWH130K2M UWH130T3V UWH130T4V	UWL130K1M UWL130K2M UWL130T3V UWL130T4V	UWN130K1M UWN130K2M UWN130T3V UWN130T4V	UWU130K1M UWU130K2M	UWU130T3V UWU130T4V
<b>160 Pound [72.6 Kg]</b>	UWH160T3V UWH160T4V	UWL160T3V UWL160T4V	UWN160T3V UWN160T4V	UWU160T3V	UWU160T4V





## Delivery Inspection

Upon delivery, visually inspect crate, protective cover, and unit for any visible shipping damage. If signs of possible damage are evident, have the carrier note the condition on the shipping papers before the shipping receipt is signed, or advise the carrier of the condition as soon as it is discovered.

## Serial Plate Location

The serial plate is located on the valve panel of the machine and, for UniLinc models, is programmed in the control. To access Machine ID through the control:

1. Press and hold , then , then  keypads at the same time.

2. Press the  keypad until Diagnostic is highlighted.
3. Press the  keypad.
4. Press the  keypad until machine ID is highlighted.
5. Press the  keypad.

Always provide the machine's serial number and model number when ordering parts or when seeking technical assistance. Refer to *Figure 1*.

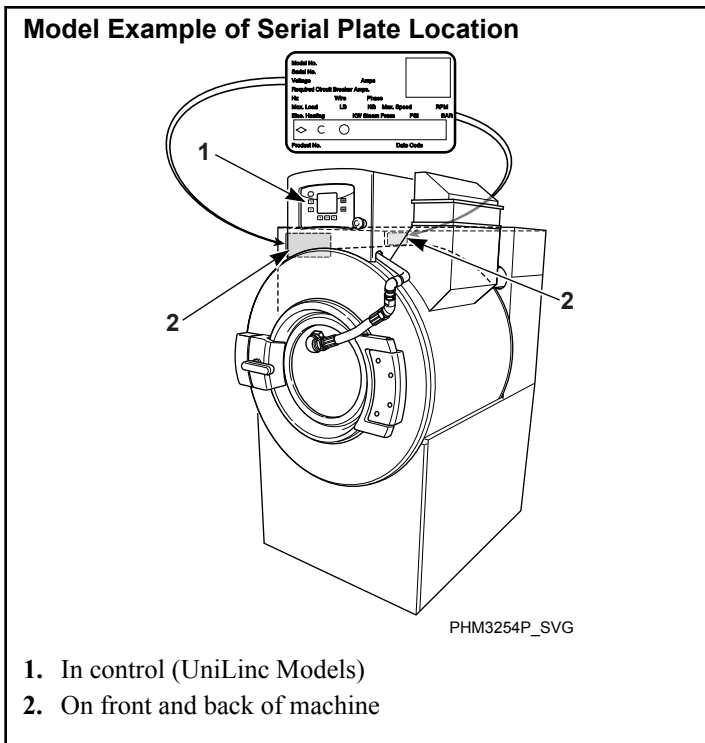

Figure 1

## Manufacturing Date

The manufacturing date for your unit can be found on the serial number. The first two digits indicate the year. The third and fourth digits indicate the month. For example, a unit with serial number 1505000001 was manufactured in May 2015.

**ERC**

## Replacement Parts

If literature or replacement parts are required, contact the source from which the machine was purchased or contact Alliance Laundry Systems at +1 (920) 748-3950 for the name and address of the nearest authorized parts distributor.

## Customer Service

For technical assistance, contact your local distributor or contact:

Alliance Laundry Systems  
Shepard Street  
P.O. Box 990  
Ripon, WI 54971-0990  
U.S.A.  
[www.alliancelaundry.com](http://www.alliancelaundry.com)  
Phone: +1 (920) 748-3121 Ripon, Wisconsin

# Specifications and Dimensions

## Specifications and Dimensions

Specifications		45	65	85	105	130	160
<b>Overall Dimensions</b>							
Overall width, in. [mm]		34.12 [867]	34.12 [867]	40.12 [1019]	40.12 [1090]	46.12 [1171]	46.12 [1171]
Overall height, in. [mm]		64.43 [1637]	64.43 [1637]	69.08 [1755]	69.08 [1755]	76.05 [1932]	76.05 [1932]
Overall depth, in. [mm]		44.33 [1126]	49.83 [1266]	51.49 [1308]	56.49 [1435]	54.50 [1384]	60.0 [1524]
<b>Weight And Shipping Information</b>							
Net weight, lbs. [kg]	Through 8/17/14	1020 [463]	1060 [481]	1670 [757]	1700 [771]	2040 [925]	2070 [939]
	Starting 8/18/14	1080 [490]	1100 [499]				
Standard shipping weight, lbs. [kg]	Through 8/17/14	1065 [483]	1105 [501]	1720 [780]	1750 [794]	2100 [953]	2130 [966]
	Starting 8/18/14	1120 [508]	1150 [522]				
Standard shipping volume, ft <sup>3</sup> [m <sup>3</sup> ]		75 [2]	75 [2]	107 [3]	107 [3]	139 [4]	139 [4]
Standard shipping dimensions (WxDxH), in. [mm]		37.2 x 53.8 x 65 [945 x 1370 x 1650]	37.2 x 53.8 x 65 [945 x 1370 x 1650]	43.2 x 61.8 x 69.4 [1097 x 1570 x 1763]	43.2 x 61.8 x 69.4 [1097 x 1570 x 1763]	49.2 x 64.8 x 76.4 [1250 x 1646 x 1941]	49.2 x 64.8 x 76.4 [1250 x 1646 x 1941]
Slat crate shipping weight, lbs. [kg]	Through 8/17/14	1190 [540]	1230 [558]	1870 [848]	1900 [862]	2260 [1025]	2290 [1039]
	Starting 8/18/14	1250 [567]	1280 [581]				
Slat crate shipping volume, ft <sup>3</sup> [m <sup>3</sup> ]		97 [3]	97 [3]	158 [4.5]	158 [4.5]	186 [5.3]	186 [5.3]
Slat crate shipping dimensions (WxDxH), in. [mm]		41.7 x 56.8 x 70.8 [1060 x 1440 x 1800]	41.7 x 56.8 x 70.8 [1060 x 1440 x 1800]	47.7 x 64.8 x 88.3 [1212 x 1646 x 2243]	47.7 x 64.8 x 88.3 [1212 x 1646 x 2243]	53.7 x 67.8 x 88.3 [1364 x 1722 x 1915]	53.7 x 67.8 x 88.3 [1364 x 1722 x 1915]
<b>Wash Cylinder Information</b>							
Cylinder diameter, in. [mm]		31 [787]	31 [787]	36 [914]	36 [914]	42 [1067]	42 [1067]
Cylinder depth, in. [mm]		16.6 [4222]	22.1 [561]	22 [559]	27 [686]	24.5 [622]	30 [762]
Cylinder volume, ft <sup>3</sup> [l]		7.3 [185]	9.7 [246]	13 [368]	15.9 [450]	19.6 [555]	24.1 [682]
Perforation size, in. [mm]		0.188 [4.8]	0.188 [4.8]	0.188 [4.8]	0.188 [4.8]	0.188 [4.8]	0.188 [4.8]
Perforation open area, %		21.3	21.3	23	23.4	27.4	27.9
<b>Door Opening Information</b>							

Table 1 *continues...*

Specifications		45	65	85	105	130	160
Door opening size, in. [mm]		17.8 [452]	17.8 [452]	21.0 [533]	21.0 [533]	24.8 [630]	24.8 [630]
Height of door bottom above floor, in. [mm]		28.09 [713]	28.09 [713]	28.09 [713]	28.09 [713]	29.84 [758]	29.84 [758]
<b>Drive Train Information</b>							
Number of motors in. drive train		1	1	1	1	1	1
Drive motor power, hp [kW]		5.0 [3.7] (V-speed)	5.0 [3.7] (V-speed)	7.5 [5.6]	7.5 [5.6]	10 [7.5]	10 [7.5]
<b>Cylinder Speeds / Centrifugal Force Data</b>							
1/2 Wash/reverse, rpm [g]		30 [0.4]	30 [0.4]	28 [.4]	28 [.4]	26 [.4]	26 [.4]
Wash/reverse, rpm [g]		42 [.78]	42 [.78]	39 [.78]	39 [.78]	36 [.77]	36 [.77]
Distribution, rpm [g]		75 [2.5]	75 [2.5]	70 [2.5]	70 [2.5]	65 [2.5]	65 [2.5]
Very Low extract, rpm [g]		248 [27]	248 [27]	230 [27]	230 [27]	213 [27]	213 [27]
Low extract, rpm [g]		477 [100]	477 [100]	443 [100]	443 [100]	410 [100]	410 [100]
Medium extract, rpm [g]		674 [200]	674 [200]	626 [200]	626 [200]	579 [200]	579 [200]
High extract (V-speed), rpm [g]		754 [250]	754 [250]	700 [250]	700 [250]	648 [250]	648 [250]
Very High extract (V-speed), rpm [g]		826 [300]	826 [300]	766 [300]	766 [300]	710 [300]	710 [300]
Ultra High extract (V-speed), rpm [g]		954 [400]	954 [400]	N/A	N/A	N/A	N/A
<b>Balance Detection</b>							
Stability switch installed		STD	STD	STD	STD	STD	STD
<b>Direct Steam Heating (Optional)</b>							
Steam inlet connection size, in. [mm]		0.5 [13]	0.5 [13]	.5 [13]	.5 [13]	.75 [19]	.75 [19]
Number of steam inlets		1	1	1	1	1	1
Steam required to raise bath temperature, 10°F, lbs. [10°C, kg]	LOW	2.5 [1.1]	3.3 [1.5]	4.6 [2.1]	5.7 [2.6]	6.7 [3.0]	8.3 [3.8]
	MED	2.7 [1.2]	3.7 [1.7]	5.2 [2.4]	6.5 [2.9]	7.8 [3.5]	9.5 [4.3]
	HIGH	3.1 [1.4]	4.1 [1.9]	6.1 [2.8]	7.6 [3.4]	9.1 [4.1]	11.1 [5.0]
Average consumption per cycle, BHP [kg]		1.6 [25.4]	2.1 [33.4]	3.1 [49.3]	3.8 [60.4]	4.6 [73.2]	5.8 [92.2]
<b>Electrical Heating (Optional)</b>							
Total electrical heating capacity, kW	200V	19.1	19.1	28.6	28.6	N/A	N/A
	240V	27.4	27.4	41.2	41.2	N/A	N/A
	380V	17.2	17.2	17.2	17.2	34.4	N/A
	415V	20.5	20.5	20.5	20.5	41.0	N/A
	480V	27.4	27.4	27.4	27.4	54.8	N/A
Number of electrical heating elements		6/6	6/6	9/6	9/6	12	N/A

Table 1 continues...

Specifications and Dimensions

<b>Specifications</b>		<b>45</b>	<b>65</b>	<b>85</b>	<b>105</b>	<b>130</b>	<b>160</b>
Electrical heating element size, kW		4.2	4.2	4.2	4.2	4.2	N/A
Time required to raise bath temperature, min per 10°F [5.5°C]	LOW	1.7	2.4	2.2	2.8	1.7	N/A
	MED	1.9	2.7	2.5	3.2	2.0	N/A
	HIGH	2.1	3.0	3.0	3.7	2.3	N/A
Noise Emission, dB	Max Extract	80	80	80	80	80	80
	Med Extract	73	73	73	73	73	73
	Agitate	61	61	61	61	61	61

Table 1

# Machine Dimensions

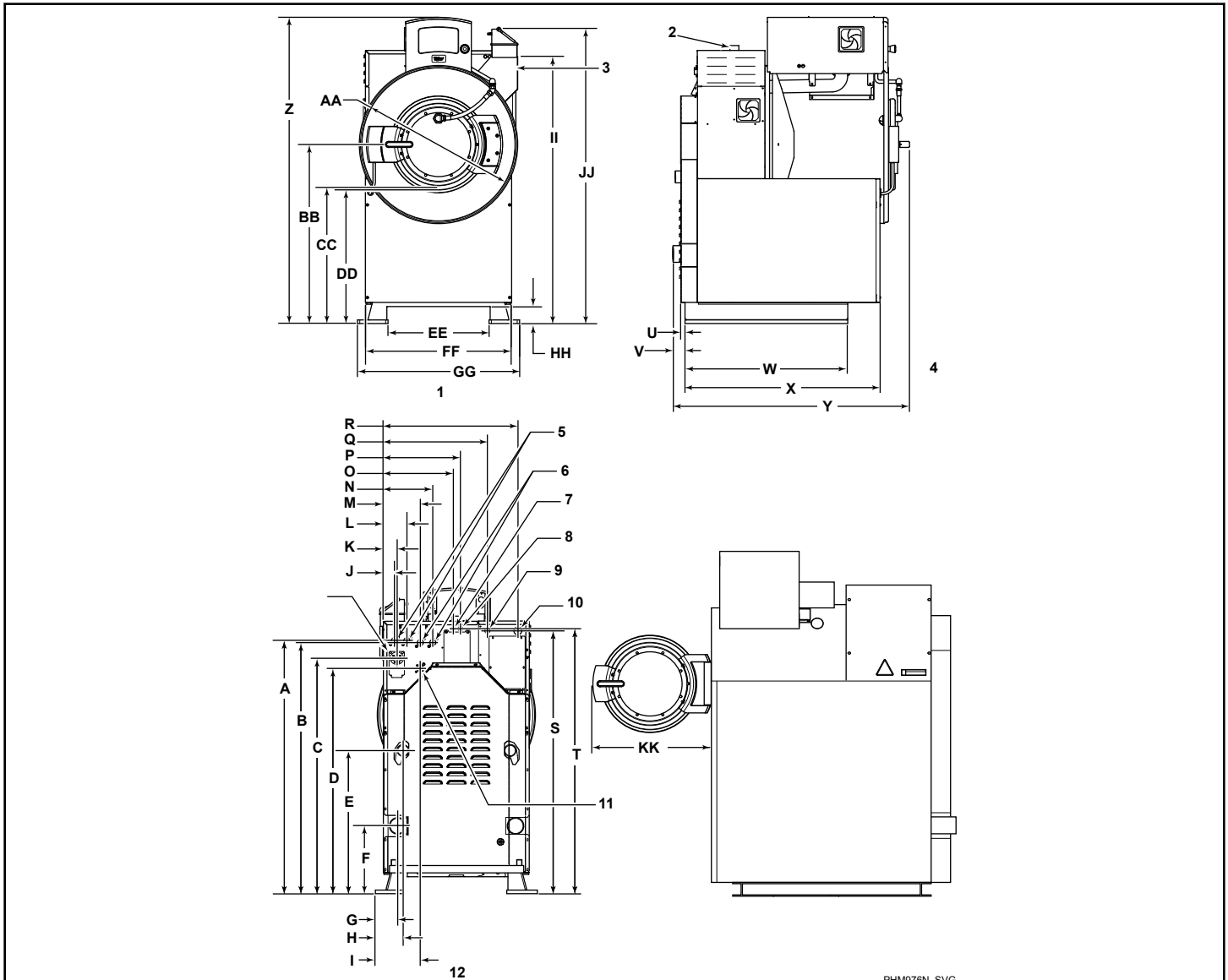

PHM976N\_SVG

**NOTE: UniLinc control model shown.**

- 1. Front View
- 2. Shell Vent
- 3. Supply Dispenser
- 4. Side View
- 5. Spray Rinse Connection
- 6. Primary Fill Connections
- 7. .875 Chem Supply Electrical
- 8. 1.125 Chem Supply Electrical
- 9. 1.125 Electrical
- 10. 1.5000 Electrical
- 11. Steam Connection
- 12. Back View

Figure 2

<b>Machine Dimensions, in. [mm]</b>						
	<b>45</b>	<b>65</b>	<b>85</b>	<b>105</b>	<b>130</b>	<b>160</b>
<b>A</b>	53.37 [1356]	53.37 [1356]	57.54 [1462]	57.54 [1462]	64.50 [1638]	64.50 [1638]
<b>B</b>	52.99 [1346]	52.99 [1346]	57.92 [1471]	57.92 [1471]	64.88 [1648]	64.88 [1648]
<b>C</b>	49.68 [1262]	49.68 [1262]	54.24 [1378]	54.24 [1378]	61.20 [1554]	61.20 [1554]
<b>D</b>	47.62 [1210]	47.62 [1210]	52.17 [1325]	52.17 [1325]	56.38 [1432]	56.38 [1432]
<b>E</b>	30.48 [774]	30.48 [774]	30.78 [782]	30.78 [782]	29.51 [750]	29.51 [750]
<b>F</b>	14.24 [362]	14.24 [362]	12.28 [312]	12.28 [312]	12.25 [311]	12.25 [311]
<b>G</b>	2.16 [55]	2.16 [55]	2.49 [63]	2.49 [63]	2.90 [74]	2.90 [74]
<b>H</b>	3.58 [91]	3.58 [91]	2.49 [63]	2.49 [63]	2.90 [74]	2.90 [74]
<b>I</b>	7.71 [196]	7.71 [196]	7.71 [196]	7.71 [196]	7.71 [196]	7.71 [196]
<b>J</b>	2.31 [59]	2.31 [59]	2.31 [59]	2.31 [59]	2.31 [59]	2.31 [59]
<b>K</b>	2.83 [72]	2.83 [72]	2.83 [72]	2.83 [72]	2.83 [72]	2.83 [72]
<b>L</b>	4.93 [125]	4.93 [125]	4.93 [125]	4.93 [125]	4.93 [125]	4.93 [125]
<b>M</b>	7.79 [198]	7.79 [198]	8.27 [210]	8.27 [210]	8.27 [210]	8.27 [210]
<b>N</b>	10.41 [264]	10.41 [264]	11.37 [289]	11.37 [289]	11.37 [289]	11.37 [289]
<b>O</b>	14.64 [372]	14.64 [372]	23.05 [585]	23.05 [585]	26.05 [662]	26.05 [662]
<b>P</b>	16.12 [409]	16.12 [409]	23.05 [585]	23.05 [585]	26.05 [662]	26.05 [662]
<b>Q</b>	21.93 [557]	21.93 [557]	27.93 [709]	27.93 [709]	33.93 [862]	33.93 [862]
<b>R</b>	28.81 [732]	28.81 [732]	34.81 [884]	34.81 [884]	40.81 [1037]	40.81 [1037]
<b>S</b>	55.43 [1408]	55.43 [1408]	59.98 [1523]	59.98 [1523]	66.94 [1700]	66.94 [1700]
<b>T</b>	55.84 [1418]	55.84 [1418]	57.42 [1458]	57.42 [1458]	64.38 [1635]	64.38 [1635]
<b>U</b>	1.01 [26]	1.01 [26]	0.88 [22]	0.88 [22]	1.11 [28]	1.11 [28]
<b>V</b>	2.49 [63]	2.49 [63]	1.88 [48]	1.88 [48]	2.16 [55]	2.16 [55]
<b>W</b>	34.24 [870]	34.24 [870]	42.24 [1073]	42.24 [1073]	44.74 [1136]	44.74 [1136]
<b>X</b>	35.63 [905]	41.13 [1045]	48.50 [1232]	48.50 [1232]	51.50 [1308]	51.50 [1308]
<b>Y</b>	44.33 [1126]	49.83 [1266]	51.49 [1308]	56.49 [1435]	54.50 [1384]	60.0 [1524]
<b>Z</b>	64.43 [1637]	64.43 [1637]	69.08 [1755]	69.08 [1755]	76.05 [1932]	76.05 [1932]
<b>AA</b>	33.69 [856]	33.69 [856]	39.45 [1002]	39.45 [1002]	45.68 [1160]	45.68 [1160]
<b>BB</b>	33.69 [856]	33.69 [856]	39.29 [998]	39.29 [998]	42.94 [1091]	42.94 [1091]
<b>CC</b>	28.78 [731]	28.78 [731]	28.78 [731]	28.78 [731]	30.54 [776]	30.54 [776]
<b>DD</b>	28.09 [713]	28.09 [713]	28.09 [713]	28.09 [713]	29.84 [758]	29.84 [758]
<b>EE</b>	20.88 [530]	20.88 [530]	22.62 [575]	22.62 [575]	28.62 [727]	28.62 [727]

Table 2 *continues...*

<b>Machine Dimensions, in. [mm]</b>						
	<b>45</b>	<b>65</b>	<b>85</b>	<b>105</b>	<b>130</b>	<b>160</b>
<b>FF</b>	30.77 [782]	30.77 [782]	36.77 [934]	36.77 [934]	42.77 [1086]	42.77 [1086]
<b>GG</b>	34.12 [867]	34.12 [867]	40.12 [1019]	40.12 [1019]	46.12 [1171]	46.12 [1171]
<b>HH</b>	3.50 [89]	3.50 [89]	3.50 [89]	3.50 [89]	3.50 [89]	3.50 [89]
<b>II</b>	60.94 [1548]	60.94 [1548]	63.88 [1623]	63.88 [1623]	68.90 [1750]	68.90 [1750]
<b>JJ</b>	64.63 [1642]	64.63 [1642]	67.59 [1717]	67.59 [1717]	72.61 [1844]	72.61 [1844]
<b>KK</b>	24.64 [626]	24.64 [626]	28.22 [717]	28.22 [717]	31.65 [804]	31.65 [804]

Table 2

# Mounting Bolt Hole Locations - 45 and 65 Pound Models

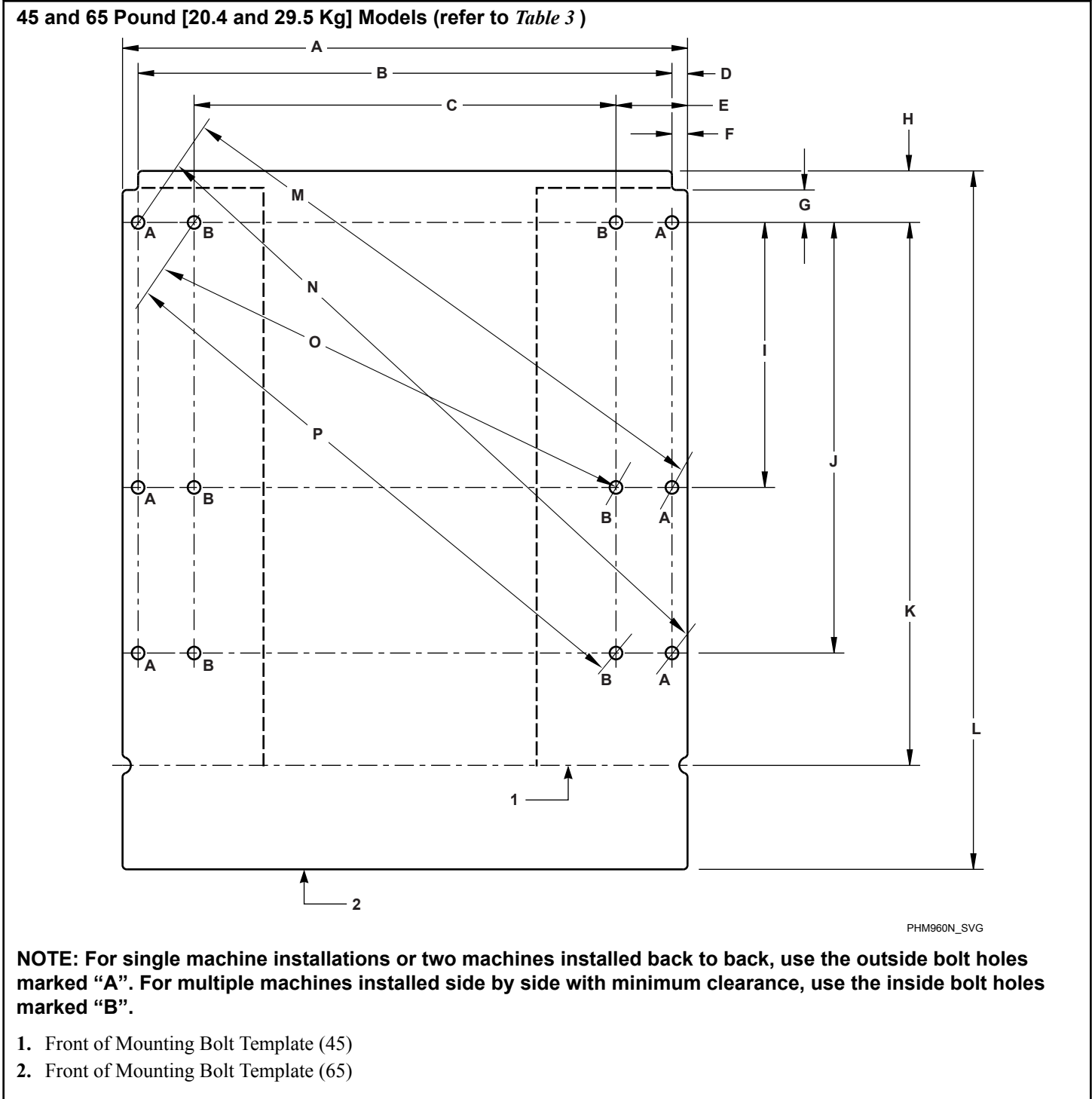

Figure 3

<b>Machine Capacity Dimensions, in. [mm] - 45 and 65 Pound [20.4 and 29.5 Kg] Models</b>			
		<b>45</b>	<b>65</b>
<b>A</b>		34.12 [867]	34.12 [867]
<b>B</b>		32.24 [819]	32.24 [819]
<b>C</b>		25.48 [647]	25.48 [647]
<b>D</b>		.94 [24]	.94 [24]
<b>E</b>		4.32 [110]	4.32 [110]
<b>F</b>		.94 [24]	.94 [24]
<b>G</b>		1.96 [50]	1.96 [50]
<b>H</b>		3 [76]	3 [76]
<b>I</b>		16 [406]	16 [406]
<b>J</b>		26 [660]	26 [660]
<b>K</b>		33.67 [855]	Not Applicable
<b>L</b>		Not Applicable	42.17 [1071]
<b>M</b>	Outside	35.99 [914]	35.99 [914]
<b>N</b>		41.41 [1051]	41.41 [1051]
<b>O</b>	Inside	30.08 [764]	30.08 [764]
<b>P</b>		36.4 [924]	36.4 [924]

Table 3

# Mounting Bolt Hole Locations - 85 and 105 Pound Models

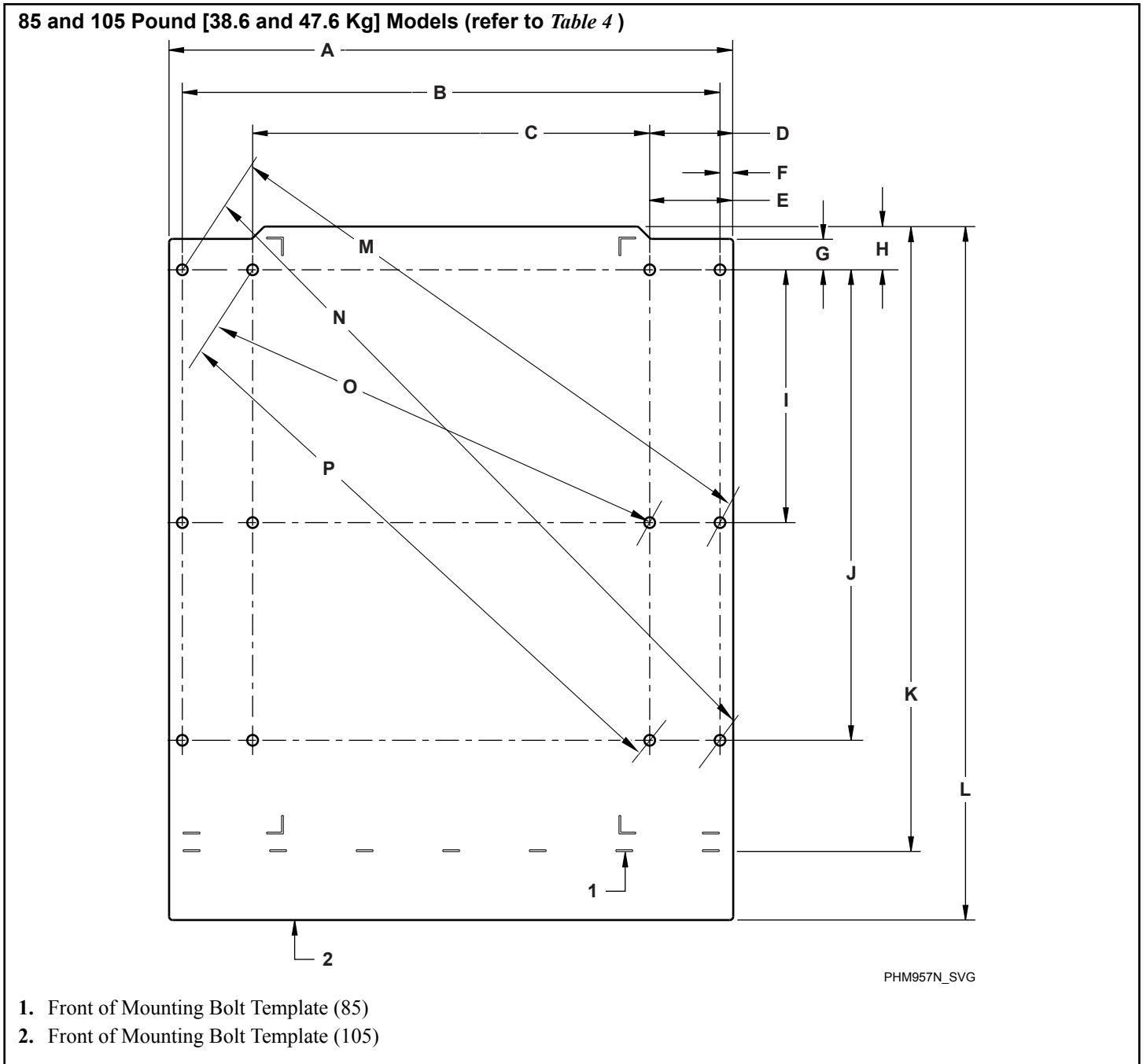

Figure 4

<b>Machine Capacity Dimensions, in. [mm] - 85 and 105 Pound [38.6 and 47.6 Kg] Models</b>			
		<b>85</b>	<b>105</b>
<b>A</b>		40.12 [1019]	40.12 [1019]
<b>B</b>		38.24 [971]	38.24 [971]
<b>C</b>		28.24 [717]	28.24 [717]
<b>D</b>		5.94 [151]	5.94 [151]
<b>E</b>		5.89 [149]	5.89 [149]
<b>F</b>		.94 [24]	.94 [24]
<b>G</b>		2.20 [56]	2.20 [56]
<b>H</b>		3.08 [78]	3.08 [78]
<b>I</b>		18 [457]	18 [457]
<b>J</b>		33.50 [851]	33.50 [851]
<b>K</b>		44.38 [1127]	Not Applicable
<b>L</b>		Not Applicable	49.38 [1254]
<b>M</b>	Outside	42.27 [1074]	42.27 [1074]
<b>N</b>		50.84 [1291]	50.84 [1291]
<b>O</b>	Inside	33.49 [851]	33.49 [851]
<b>P</b>		43.82 [1113]	43.82 [1113]

Table 4

# Mounting Bolt Hole Locations - 130 and 160 Pound Models

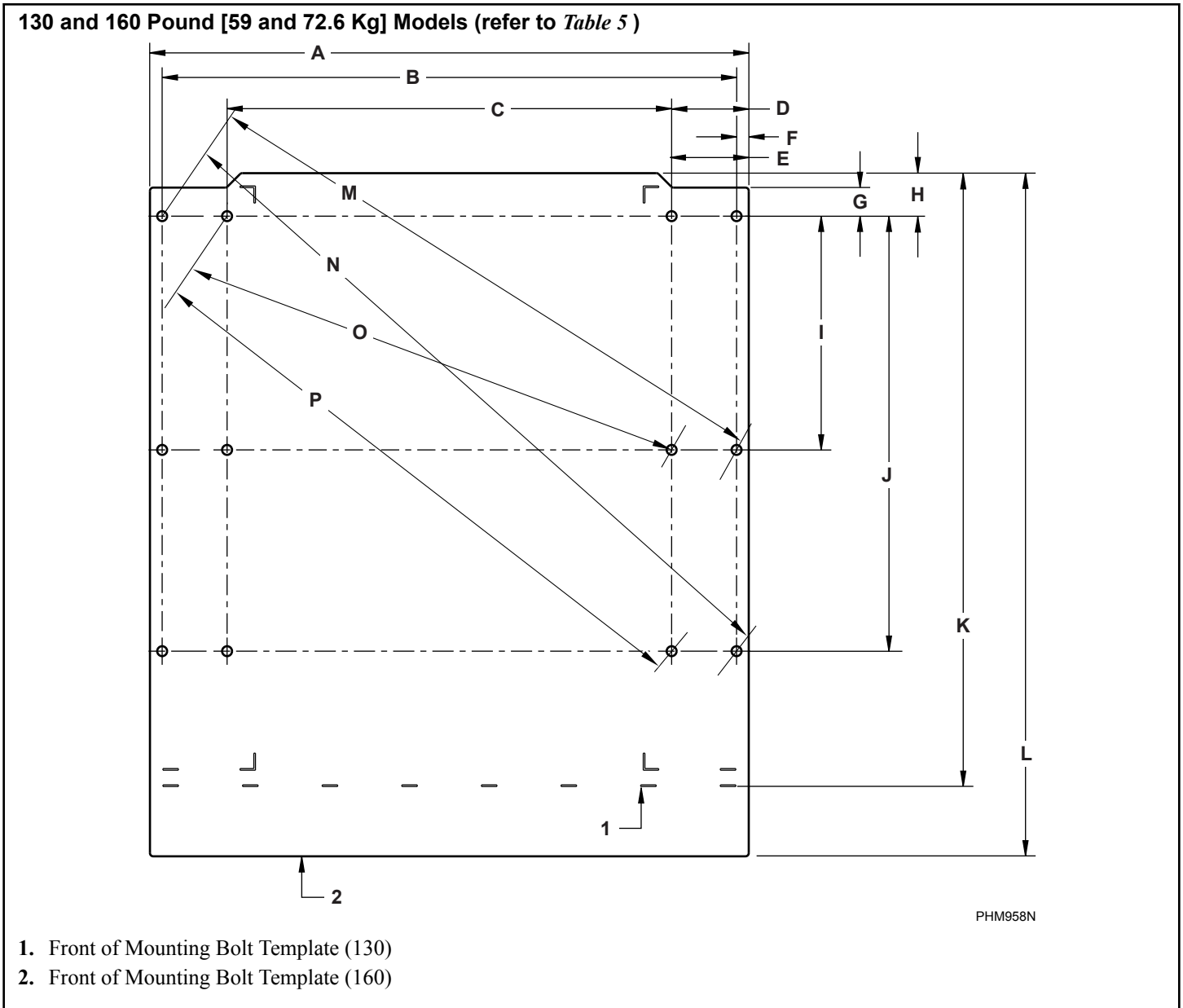

Figure 5

Machine Capacity Dimensions, in. [mm] - 130 and 160 Pound [59 and 72.6 Kg] Models		
	130	160
<b>A</b>	46.12 [1171]	46.12 [1171]
<b>B</b>	44.24 [1124]	44.24 [1124]
<b>C</b>	34.24 [870]	34.24 [870]

Table 5 continues...

<b>Machine Capacity Dimensions, in. [mm] - 130 and 160 Pound [59 and 72.6 Kg] Models</b>			
		<b>130</b>	<b>160</b>
<b>D</b>		5.94 [151]	5.94 [151]
<b>E</b>		5.89 [150]	5.89 [150]
<b>F</b>		.94 [24]	.94 [24]
<b>G</b>		2.20 [56]	2.20 [56]
<b>H</b>		3.31 [84]	3.31 [84]
<b>I</b>		18 [457]	18 [457]
<b>J</b>		33.50 [851]	33.50 [851]
<b>K</b>		47.11 [1197]	Not Applicable
<b>L</b>		Not Applicable	52.61 [1336]
<b>M</b>	Outside	47.76 [1213]	47.76 [1213]
<b>N</b>		55.49 [1409]	55.49 [1409]
<b>O</b>	Inside	43.17 [1097]	43.17 [1097]
<b>P</b>		47.90 [1217]	47.90 [1217]

Table 5

**Floor Layout**

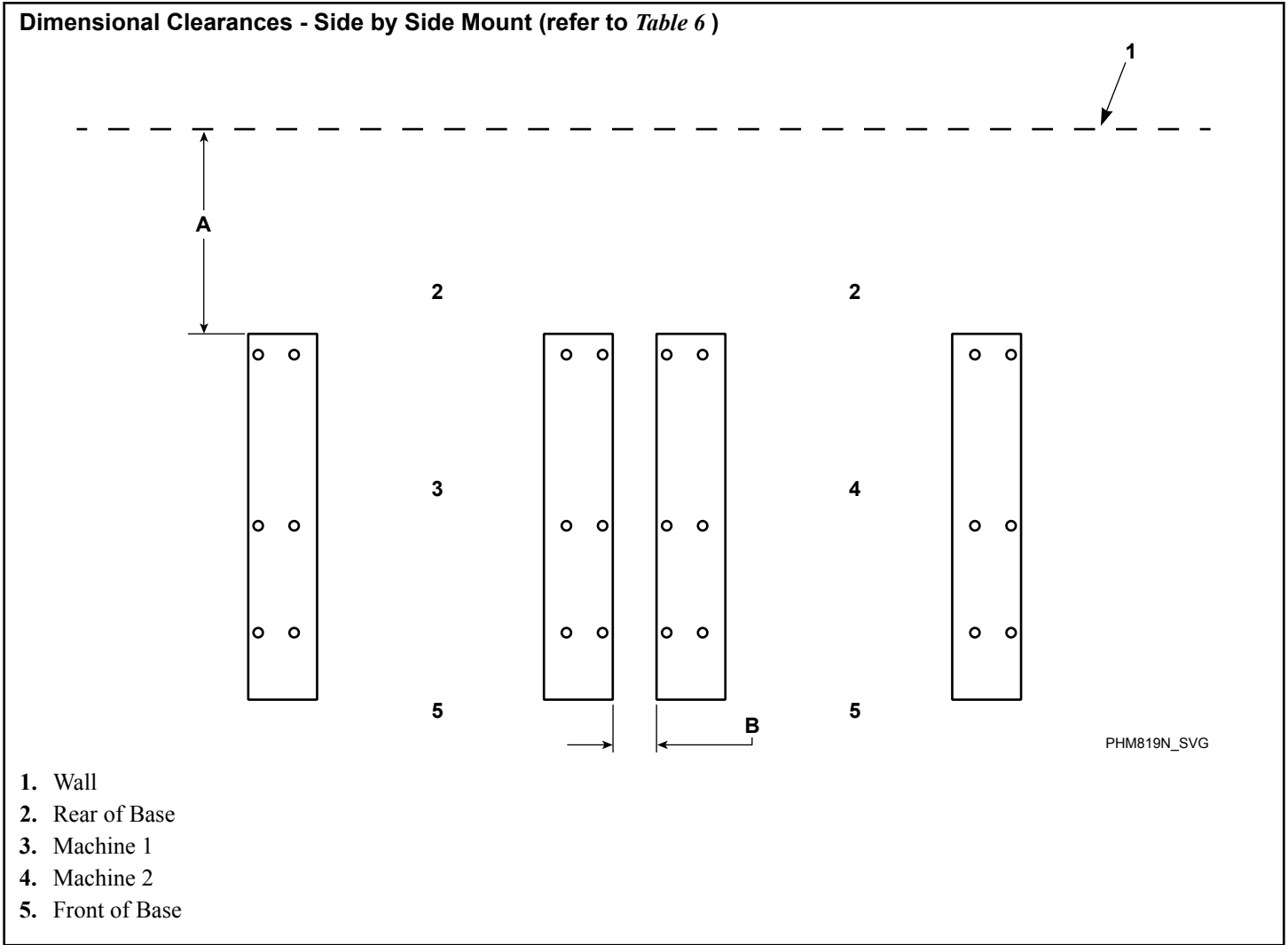
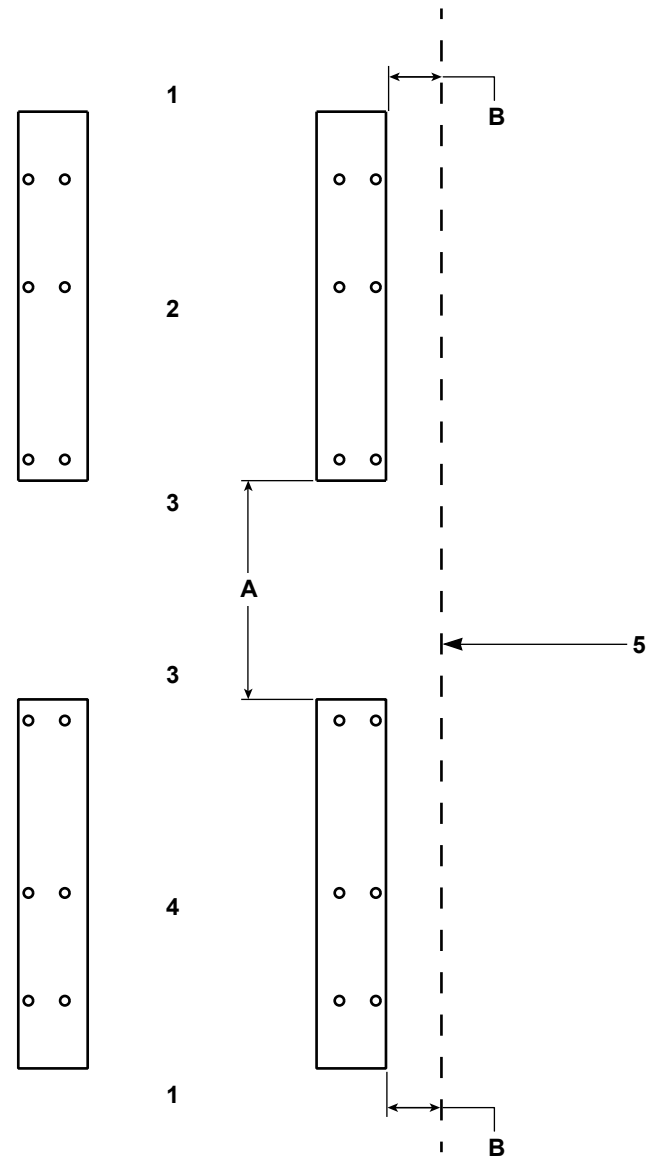

Figure 6

Dimensional Clearances, in. [mm] - Side by Side Mount		
Description		45-160
<b>A</b>	<b>Distance to wall (minimum)</b>	20 [508]
<b>B</b>	<b>Adjacent unit spacing (minimum)</b>	Standard
		Narrow*
		Ultra-narrow*
* Requires additional concrete depth and rebar. Refer to <i>Machine Installation</i> .		

Table 6

**Dimensional Clearances - Back to Back Mount (refer to *Table 7*)**



PHM810N\_SVG

- 1. Front of Base
- 2. Machine 2
- 3. Rear of Base
- 4. Machine 1
- 5. Edge of Concrete Pad or Wall

Figure 7

<b>Dimensional Clearances, in. [mm] - Back to Back Mount</b>			
<b>Description</b>		<b>45-105</b>	<b>130-160</b>
<b>A</b>	<b>Distance to back edge of machine 2 (minimum)</b>	20 [508]	20 [508]
<b>B</b>	<b>Adjacent wall spacing (minimum)</b>	Standard	12 [305]
		Narrow*	9 [226]
		Ultra-narrow*	6 [153]
* Requires additional concrete depth and rebar. Refer to <i>Machine Installation</i> .			

Table 7

### Mounting Bolt Pattern

Refer to Table 8 .

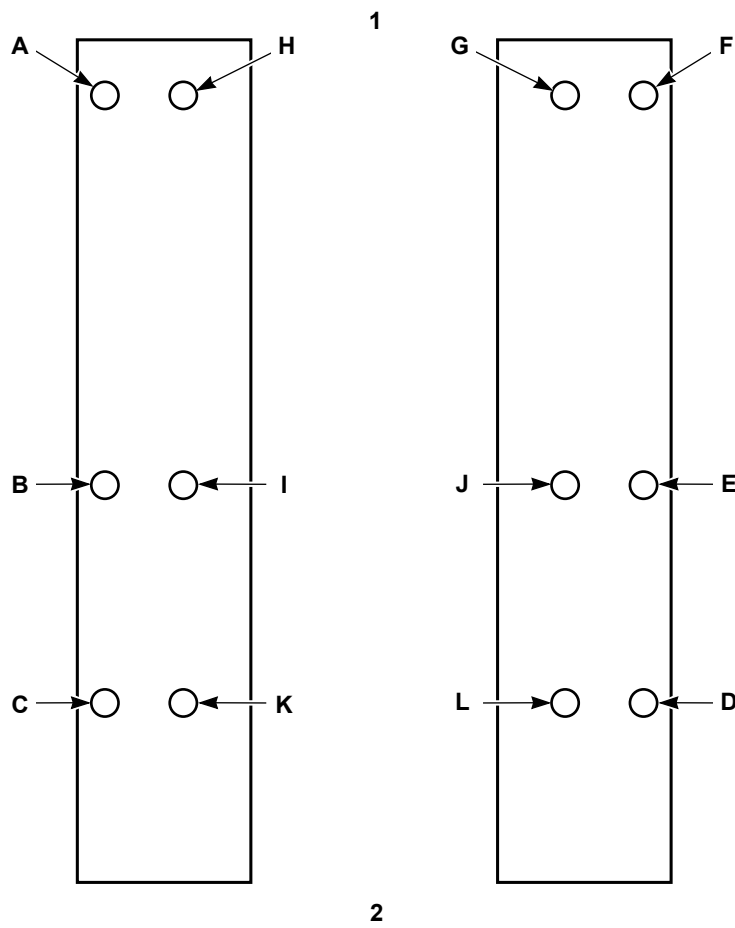

PHM938N

- 1. Rear of Machine
- 2. Front of Machine

Figure 8

Models	Required Bolts	Optional Bolts*
45-65	A-F	G-L
85-105	A-H	I-L
130-160	A-J	K-L
* For further reduction of vibration		

Table 8

### Single Machine Foundation Requirements

A minimum 3500 psi (refer to rating per supplier) reinforced concrete set on a prepared bed is required for all new machine installations.

**NOTE: Do not mount on metal base frames, wooden floors, tile floors, elevated floor levels, or over basements or crawl spaces because of the high extract speed and the G-forces exerted.**

Thoroughness of detail must be stressed with all foundation work to ensure a stable unit installation, eliminating possibilities of excessive vibration during extract.



## WARNING

**To reduce the risk of fire, serious injury, property damage and/or death, install the machine on a level (within 3/8 inch), uncovered concrete floor of sufficient strength at grade.**

W787

For new foundations a mounting bolt template is available at extra cost or use machine base if available.

The machine must be anchored to a smooth level surface so that the entire base of the machine is supported and rests on the mounting surface.

**IMPORTANT: Do not permanently support the machine on only four points with spacers. Grouting is required and spacers must be removed.**

## Machine Installation on Existing Floor

The existing floor slab must be reinforced concrete without voids under slab and meet depth requirements per *Table 10*. If the floor meets these requirements and an elevated pad is NOT desired, refer to *Figure 9* and proceed to *Machine Mounting and Grouting* section.

## Elevated Pad Installation on Existing Floor

The existing floor slab must be 6 inches [152 mm] thick reinforced concrete without voids under slab. If the slab meets these requirements and an elevated pad is desired, refer to *Figure 10* and proceed to *Machine Foundation and Pad Installation* section.

## New Foundation

If the existing floor slab does not meet the single machine foundation requirements, refer to *Figure 11* and proceed to *Machine Foundation and Pad Installation* section.

## Isolated Pad Installation

This type of installation is NOT recommended. Installer MUST consult a Structural Engineer for concrete specifications and requirements for installations that will not be tied into adjacent foundations.

**IMPORTANT: The above instructions and recommendations are conservative specifications for a typical installation based on consultations with a structural engineer. Alliance Laundry Systems stands behind all installations meeting these specifications. For alternate installation specifications based on your soil type, location, building structure, unique floor geometry, machine types, and utilities, consult a structural engineer in your local area.**

## Machine Foundation and Pad Installation

A concrete pad may be constructed to elevate a machine. Care must be exercised in the design of the pad due to the force exerted by the machine during extract. This concrete pad, recommended not to exceed 8 inches [203 mm] above existing floor, must be placed, reinforced with rebar and tied to the existing floor. Refer to *Table 9*, *Figure 9*, *Figure 10* and *Figure 11* for multiple machine installations.

Machine Foundation and Pad Installation, in. [mm]					
Specifications		45	65	85-105	130-160
Minimum Foundation Thickness*	L-speed	6 [152]	6 [152]	N/A	N/A
	M-speed	6 [152]	8 [203]	12 [305]	12 [305]
	V-speed	12 [305]	12 [305]	12 [305]	12 [305]
Minimum Excavation Depth	L-speed	12 [305]	12 [305]	N/A	N/A
	M-speed	12 [305]	14 [356]	18 [457]	18 [457]
	V-speed	18 [457]	18 [457]	18 [457]	18 [457]
<b>Minimum Pad Size</b>					
Single machine (WxD)		60 x 60 [1524 x 1524]		65.12 x 67.75 [1654 x 1721]	74.25 x 80 [1886 x 2032]
Two machines, Side-by-side (WxD)		98 x 60 [2489 mm x 1524 mm]		123.25 x 67.75 [3131 x 1721]	138.38 x 80 [3515 x 2032]
Two machines, Back-to-back (WxD)		60 x 106 [1524 x 2692]		65.12 x 135.5 [1654 x 3442]	74.25 x 160 [1886 x 4064]
Three machines, Side-by-side (WxD)		138 x 60 [3505 x 1524]		181.37 x 67.75 [4607 x 1721]	202.5 x 80 [5144 x 2032]
* Installing additional concrete mass (thicker foundation) will further reduce vibration and install risk.					

Table 9

**IMPORTANT: Do NOT install a pad on top of the existing floor. The foundation and pad must be constructed and tied together as one piece.**

If the existing floor is not reinforced concrete at least 12 inches [305 mm] thick, an elevated pad is desired or multiple machines are to be installed, the following steps must be performed (refer to *Figure 9*, *Figure 10* and *Figure 11*):

- Cut a hole larger on all sides than the machine base through the existing floor, refer to *Table 9*.
- Excavate to a depth as indicated in *Table 9* from the top of the existing floor.
- If installing a foundation with elevated pad, prepare a form for the above-ground portion of the foundation. Verify that the top of the foundation is level. The height of the foundation pad must not exceed 8 inches [203 mm] above the existing floor.
- Backfill with clean fill dirt.
- Compact backfill, making sure to allow for correct concrete thickness.
- Drill holes (refer to manufacturer's requirements for drill hole size) for the perimeter reinforcing bar at a depth of 2.5 inches [64 mm] into the existing floor. The reinforcing should be 12 inches [305 mm] on center each way around entire perimeter.
- Clean out debris from each reinforcing bar hole.
- Fill half the hole depth with acrylic adhesive.
- Using #4 [60 ksi] reinforcing bar, tie new pad to existing floor making sure to tie reinforcing bars at the intersections and using proper reinforcing bar supports to hold bars at the proper depth in the pad.
- Allow adhesive around reinforcing bar to cure properly, refer to adhesive manufacturer for recommended cure times.

11. Completely fill with 3500 psi concrete up to the existing foundation level plus any added level (maximum of 8 inch [203 mm]) for the desired elevated pad. The concrete must be poured so that the entire foundation and pad cures as one piece.
12. Allow concrete to cure, refer to manufacturer’s recommended cure times.
13. Using a mounting bolt template or machine base, mark where the holes should be drilled to mount the machine.

**NOTE: As an alternate method, cast in the Grade 5 (minimum SAE rating), .75 inch [19 mm] anchor bolts as the concrete is poured, refer to *Figure 13* . Ensure that the bolt threads extend a minimum of 2.75 inches [70 mm] above floor level and a minimum of 6 inches [152 mm] of the bolt is embedded in concrete.**

14. Proceed to *Machine Mounting and Grouting* section.

## Machine Installation

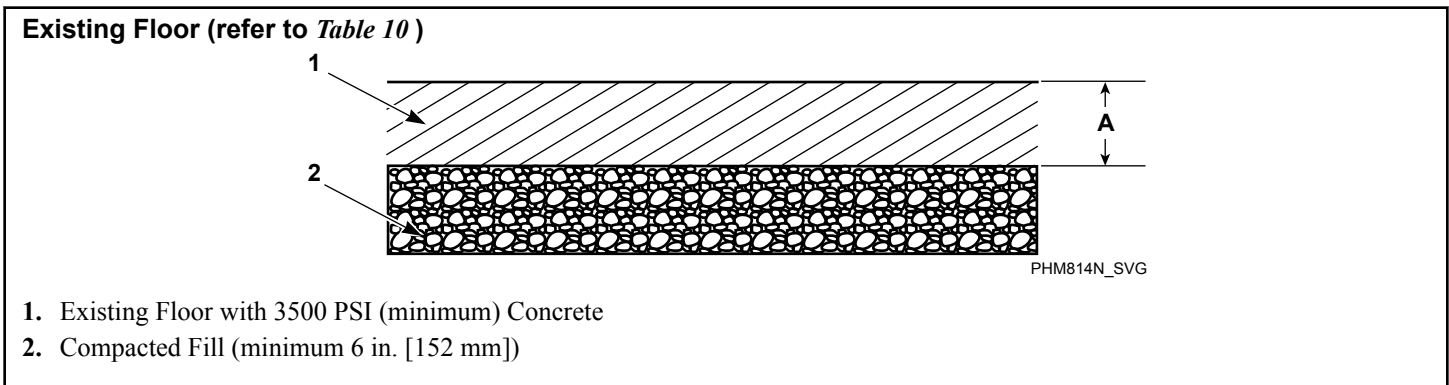

Figure 9

		Existing Floor, in. [mm]					
Description			L-speed, 45 (M-speed)	65 (M-speed)	45-65 (V-speed)	85-105	130-160
A	Required thickness of existing floor (minimum)	Standard*	6 [152]	8 [203]	12 [305]	12 [305]	12 [305]
		Narrow*	8 [203]	10 [254]	14 [356]	14 [356]	14 [356] (Side-by-side) 18 [457] (Back-to-back)
		Ultra-narrow*	10 [254]	12 [305]	16 [406]	16 [406]	20 [508] (Side-by-side) 20 [508] (Back-to-back)
* Refer to <i>Floor Layout</i> .							

Table 10

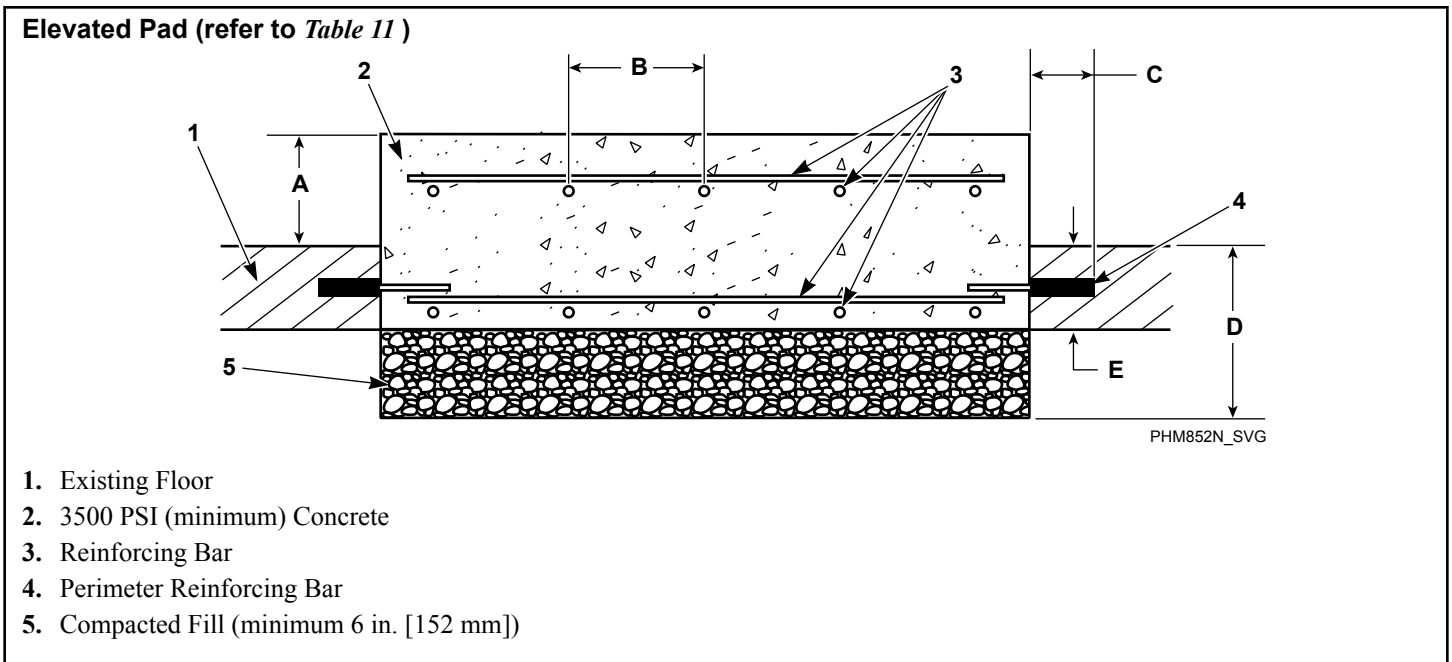

Figure 10

Elevated Pad, in. [mm]							
Description			L-speed,	65	45-65	85-105	130-160
			45	(M-speed)	(V-speed)		
<b>A</b>	<b>Height of elevated pad above floor (maximum)</b>		8 [203]	8 [203]	8 [203]	8 [203]	8 [203]
<b>B</b>	<b>Distance between reinforcing bars (maximum)</b>	Standard*	12 [305]	12 [305]	12 [305]	12 [305]	12 [305]
		Narrow*	6 [152]	6 [152]	6 [152]	6 [152]	6 [152]
		Ultra-narrow*	6 [152]	6 [152]	6 [152]	6 [152]	6 [152]
<b>C</b>	<b>Length of reinforcing bar extending into existing Floor (minimum)</b>		2.5 [64]	2.5 [64]	2.5 [64]	2.5 [64]	2.5 [64]

Table 11 continues...

Elevated Pad, in. [mm]							
Description			L-speed, 45 (M-speed)	65 (M-speed)	45-65 (V-speed)	85-105	130-160
<b>D</b>	<b>Total depth of foundation (concrete plus 6 in. [152 mm] fill) (minimum)</b>	Standard*	12 [305]	14 [356]	18 [457]	18 [457]	18 [457]
		Narrow*	14 [356]	16 [406]	20 [508]	20 [508]	20 [508] (Side-by-side) 24 [610] (Back-to-back)
		Ultra-narrow*	16 [406]	18 [457]	22 [559]	22 [559]	26 [660] (Side-by-side) 26 [660] (Back-to-back)
<b>E</b>	<b>Required thickness of existing floor (minimum)</b>		6 [152]	6 [152]	6 [152]	6 [152]	6 [152]

\* Refer to *Floor Layout*.

Table 11

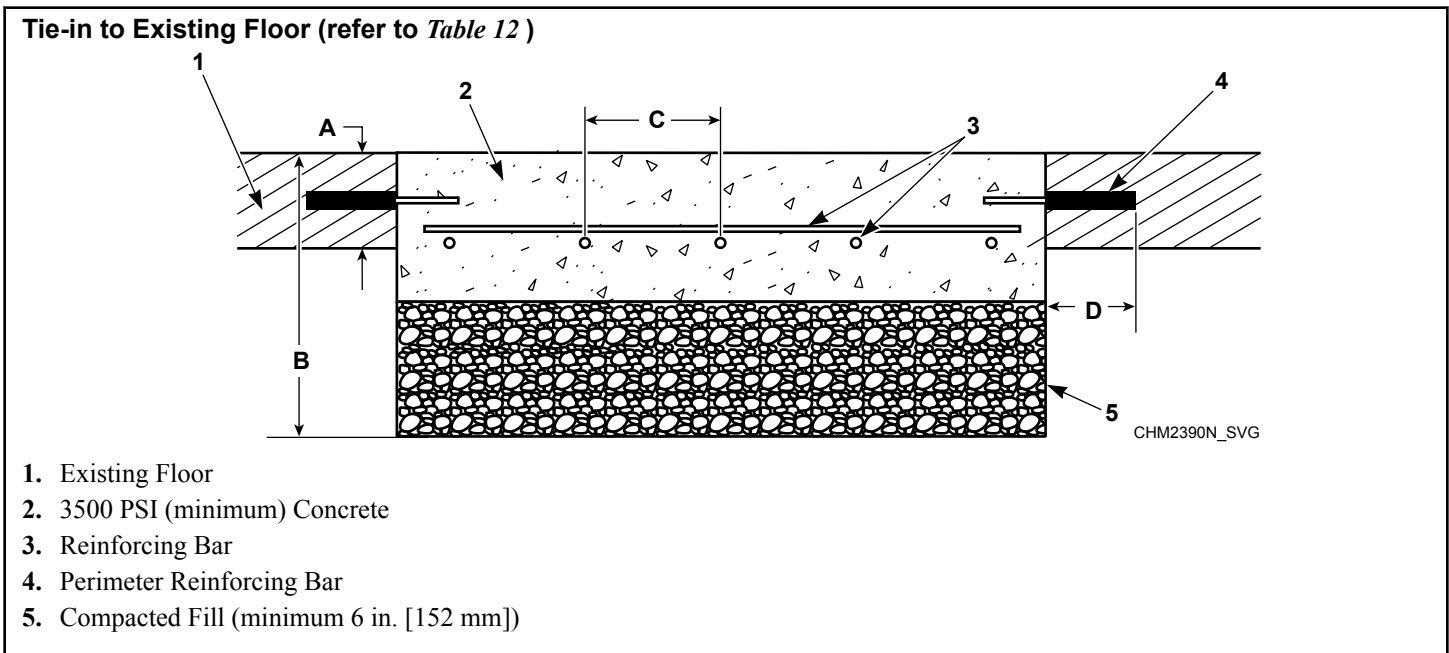

Figure 11

Tie-in to Existing Floor, in. [mm]							
Description		L-speed, 45 (M-speed)	65 (M-speed)	45-65 (V-speed)	85-105	130-160	
<b>A</b>	<b>Required thickness of existing floor (minimum)</b>	6 [152]	6 [152]	6 [152]	6 [152]	6 [152]	
<b>B</b>	<b>Total depth of foundation (concrete plus 6 in. [152 mm] fill)(minimum)</b>	Standard*	12 [305]	14 [356]	18 [457]	18 [457]	18 [457]
		Narrow*	14 [356]	16 [406]	20 [508]	20 [508]	20 [508] (Side-by-side) 24 [610] (Back-to-back)
		Ultra-narrow*	16 [406]	18 [457]	22 [559]	22 [559]	22 [559] (Side-by-side) 26 [660] (Back-to-back)
<b>C</b>	<b>Distance between reinforcing bars (maximum)</b>	Standard*	12 [305]	12 [305]	12 [305]	12 [305]	12 [305]
		Narrow*	6 [152]	6 [152]	6 [152]	6 [152]	6 [152]
		Ultra-narrow*	6 [152]	6 [152]	6 [152]	6 [152]	6 [152]
<b>D</b>	<b>Length of reinforcing bar extending into existing floor (minimum)</b>	2.5 [64]	2.5 [64]	2.5 [64]	2.5 [64]	2.5 [64]	
* Refer to <i>Floor Layout</i> .							

Table 12

## Machine Mounting and Grouting

**NOTE:** After the concrete has cured completely and the cast-in-place method was used, refer to *Figure 13* and proceed to step 7. If acrylic adhesive anchors are desired, refer to *Figure 12* and proceed with step 1 after concrete has cured completely.

1. Refer to *Figure 12* to set the drill depth gauge.
2. Drill the holes to the set depth.
3. Use compressed air or squeeze bulb to clean out debris from each hole. Use a vacuum to remove fine dust.
4. Fill half the hole depth with an industry-accepted adhesive anchoring system.
5. Insert anchor bolt until it reaches the bottom and a minimum of 2-3/4 in. [70 mm] extends above surface and a minimum of 6 inches [152 mm] is embedded in concrete.

6. Ensure all air pockets are removed from adhesive surrounding the bolt.
  7. Allow adhesive around bolt to cure completely.
- IMPORTANT: Refer to bolt manufacturer’s recommended adhesive cure times.**
8. Remove shipping materials and place the machine carefully over the bolts. Never attempt to lift the machine by the door handle or by pushing on the cover panels. Always insert a pry bar or other lifting device under the bottom frame of the machine to move it.
  9. Raise and level the machine 1/2 inch [12.7 mm] off the floor on four corners, using spacers such as nut fasteners.

	<b>WARNING</b>
<p><b>Crush hazard. To avoid personal injury and/or property damage, do not tip the machine more than 25 degrees in any direction.</b></p>	
W793	

10. Following the manufacturer's instructions, mix a good quality **non-shrinking machinery precision grout**. The grout should not be too runny or too dry and should flow into place easily. Completely fill the space between the machine base and the floor with grout to ensure a stable installation. Grout completely under frame (if bolted with inside pattern, remove front panel and back panel to gain access to all frame members). Refer to *Figure 3*. Force grout under machine base until all voids are filled.

**IMPORTANT: Minimum Grade 5, SAE rating, flat washers and minimum Grade 5, SAE rating, serrated hex flange locknuts are the recommended hardware for anchoring machine to bolts.**

11. Position the flat washers and locknuts on the anchor bolts and finger-tighten to machine base.
12. Allow machine grout to set (stiffen), but not cure.
13. **Remove the spacers carefully, allowing the machine to settle into the wet grout.** Pack any remaining voids with grout.
14. After the grout is completely cured, torque the locknuts to  $160 \pm 16$  ft.-lbs. – one after the other – until all are tightened evenly and the machine is fastened securely to the floor.

**IMPORTANT: Refer to recommended grout cure times from manufacturer before torquing locknuts.**

**IMPORTANT: All torque joints must remain dry (non-lubricated).**

**NOTE: Check and retighten the locknuts after five to ten days of operation and every month thereafter.**

#### Acrylic Adhesive Anchors (refer to *Table 13*)

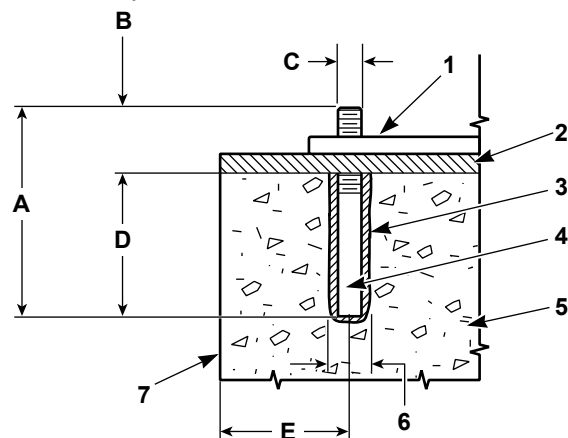

PHM811N\_SVG

**NOTE: \*Available for purchase through the distributor.**

1. Machine Frame Base
2. Grout 1/2 in. [13 mm]
3. Acrylic Adhesive\*
4. Anchor Bolt\* (minimum Grade 5 SAE rating)
5. Concrete
6. Drill Hole Size per Manufacturer Requirements
7. Edge of Pad

Figure 12

**Cast-in-place Anchors (refer to Table 13)**

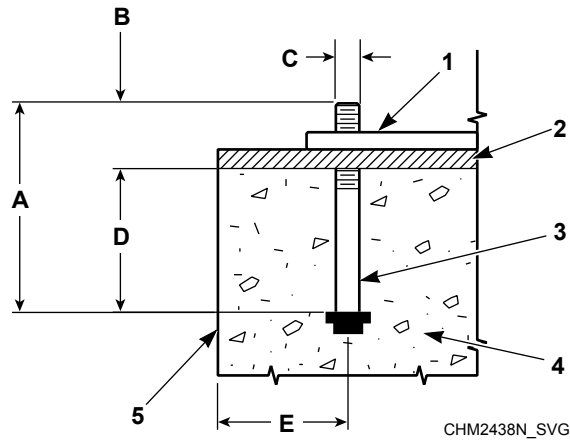

1. Machine Frame Base
2. Grout
3. Anchor Bolt (minimum Grade 5 SAE rating)
4. Concrete
5. Edge of Pad

Figure 13

Minimum Anchoring Specifications, in. [mm]		
<b>A</b>	Bolt Length	8-3/4 [22]
<b>B</b>	Thread Extension (minimum)	2-3/4 [70]
<b>C</b>	Bolt Diameter	3/4 [19]
<b>D</b>	Embedment Depth	6 [152]
<b>E</b>	Distance from Bolt Center to Edge of Concrete Pad	12 [305]

Table 13

## Floor Load Data

Floor Load Data							
Specifications		45	65	85	105	130	160
Static load, lb [kN]		1280 [5.7]	1350 [6.0]	1990 [8.9]	2100 [9.3]	2540 [11.3]	2670 [11.9]
Static pressure, lb/ft <sup>2</sup> [kN/m <sup>2</sup> ]		158 [7.6]	167 [8.0]	170 [8.1]	179 [8.6]	178 [8.5]	187 [9.0]
Maximum dynamic load, lb [kN]		2690 [12]	2690 [12]	3300 [14.5]	3300 [14.5]	4200 [18.7]	4200 [18.7]
Maximum dynamic pressure, lb/ft <sup>2</sup> [kN/m <sup>2</sup> ]		483 [23.1]	493 [23.6]	446 [21.4]	457 [21.9]	469 [22.5]	479 [22.9]
Dynamic load frequency, Hz	L-Speed	8	8	N/A	N/A	N/A	N/A
	M-Speed	11.25	11.25	9.9	9.9	9.7	9.7
	V-Speed	15.9	15.9	12.8	12.8	11.8	11.8
<sup>1</sup> Maximum vertical load,		3980 [17.7]	4050 [18.0]	5290 [23.5]	5400 [24]	6740 [30]	6870 [30.6]
Maximum base moment, lb-ft [kN-m]		8470 [37.7]	8480 [37.7]	10700 [14.5]	10700 [14.5]	15000 [20.3]	15000 [20.3]
<sup>1</sup> Acting in the downward direction against the floor.							

Table 14

## Drain Connection Requirements

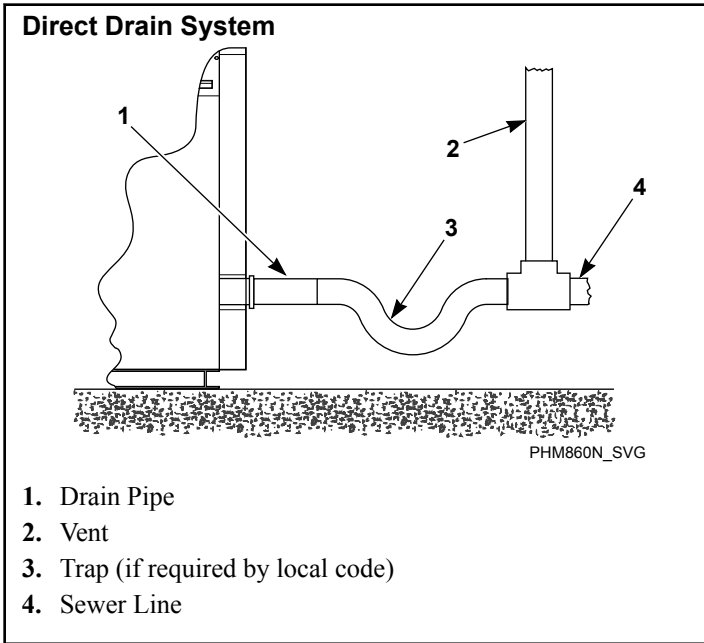

Figure 14

All drain systems must be vented to prevent an air lock and to prevent siphoning.

Refer to *Figure 14* .

**IMPORTANT: Machines must be installed in accordance with all local codes and ordinances.**

If proper drain size is not available or practical, a surge tank is required. A surge tank along with a sump pump should be used when gravity drainage is not possible.

Increasing the drain hose length, installing elbows, or causing bends will decrease drain flow rate and increase drain times, impairing machine performance.

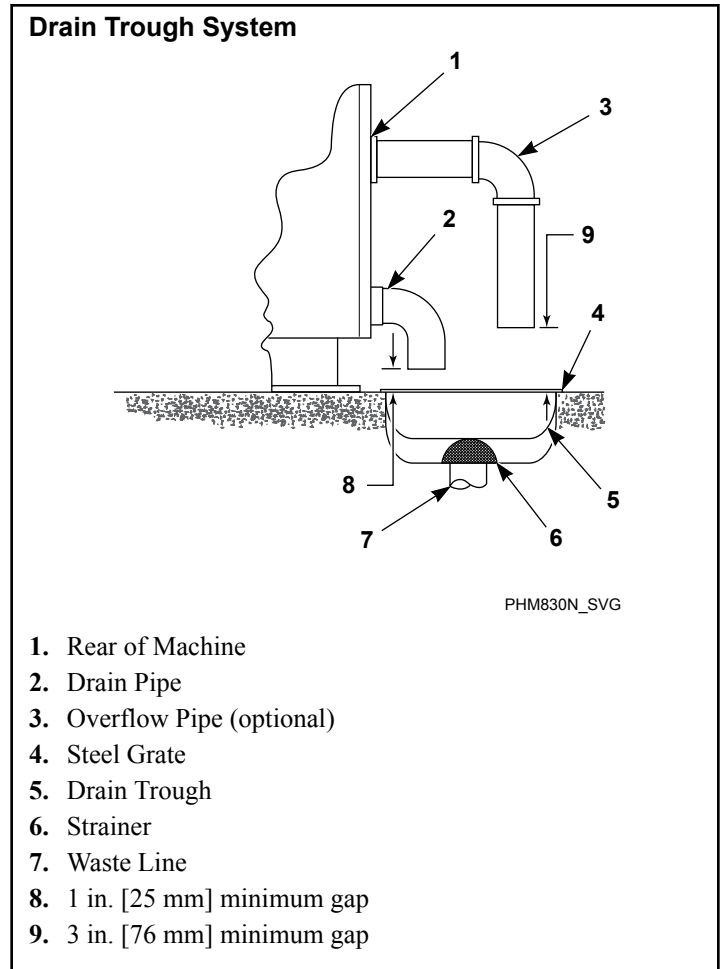

Figure 15

Refer to *Table 16* for capacity-specific drain information.

**IMPORTANT: Do not block the machine overflow opening.**

If water or suds flow from the machine overflow vent and the machine has been verified to be operating properly with proper water levels and correct amount of laundry chemicals, a drain line or an extension may be added to the machine overflow vent and routed to a drain trough.

1. To build a drain line, route the drain pipe from the machine overflow vent to a drain trough. As an option, the drain pipe can instead be routed straight across or down and be suspended above drain trough by at least 3 inches [76 mm].
2. To build an extension to the overflow vent, secure a section of drain pipe to the vent, facing upward, that extends no higher than the recommended height above the edge of the vent elbow. Refer to *Figure 16* and *Table 15* .

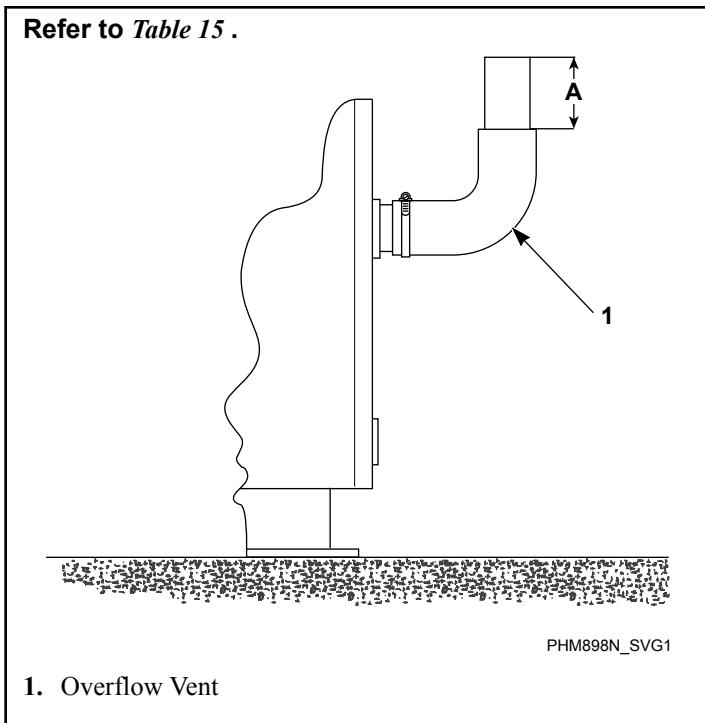

Figure 16

Vent Extension (maximum), in. [mm]			
	45-65	85-150	130-160
A	4 [102]	3.5 [89]	8.25 [210]

Table 15

3. Secure the drain pipe with the hose clamp.

**IMPORTANT: Do not route the machine overflow to a direct drain system.**

Drain Information							
Specifications		45	65	85	105	130	160
Drain connection size, O.D., in. [mm] with second drain:		3 [76]	3 [76]	3 [76]	3 [76]	3 [76]	3 [76]
Number of drain outlets	UniLinc	1	1	2	2	2	2
	M30	1	1	1	1	1	N/A
Drain flow capacity, gal/min. [l/min.]		55 [208]	55 [208]	120 [454]	120 [454]	140 [530]	140 [530]
Maximum discharge (level 30), gal [l]		18.18 [68.8]	25.56 [96.8]	29.50 [111.7]	33.76 [127.8]	43.02 [162.8]	44.69 [169.2]
Recommended drain pit size, ft <sup>3</sup> [l] †		5 [142]	6 [170]	8 [227]	10 [283]	12 [340]	14.5 [411]
† Sized for one machine using overflow level.							

Table 16

## Water Connection

Maximum water inlet temperature is 190 °Fahrenheit [88 °Celsius].

Connections should be supplied by hot and cold water lines of at least the sizes shown in the Water Supply Line Sizing table. Installation of additional machines will require proportionately larger water lines. Refer to *Table 18*.

		<b>WARNING</b>		
To prevent personal injury, avoid contact with inlet water temperatures higher than 125° Fahrenheit [51° Celsius] and hot surfaces.				
W748				
Water Supply Information				
Specifications		45-65	85-105	130-160
Number of main fill water inlets		2	2	2
Main fill and spray rinse (UniLinc only) inlet size at machine, in. [mm]		3/4 [19]	3/4 [19]	1 [25]
End of factory supplied hose	Size, in. [mm]	3/4 [19]	3/4 [19]	1 [25]
	Thread Pitch, GHT [BSPP]	3/4 x 11.5 [3/4 x 14]	3/4 x 11.5 [3/4 x 14]	1 x 11.5 [1 x 14]
Number of spray rinse water inlets (UniLinc only)		2	2	2
Spray rinse water inlet size (UniLinc only), in. [mm]		3/4 [19]	3/4 [19]	3/4 [19]
Required pressure (max-min), psi [kPa]		20-85 [140-570]	30-85 [200-570]	30-85 [200-570]
Inlet flow capacity for main fill (warm fill, both inlet valves open), gal/min at 85 psi [l/min at 1232 Pa]		45 [170]	45 [118]	54 [204]
Inlet flow capacity for spray rinse (warm fill, both inlet valves open), gal/min at 85 psi [l/min at 1232 Pa]		22 [83]	22 [83]	22 [83]

Table 17

To connect water service to machine with rubber hoses, use the following procedure:

1. Before installing hoses, flush the water system for at least two minutes.
2. Check filters in the machine's inlet hoses for proper fit and cleanliness before connecting.
3. Hang the hoses in a large loop; do not allow them to kink.

If additional hose lengths are needed or using hoses other than those supplied by manufacturer, flexible hoses with screen filters are required.

Lower pressures will increase fill times.

Suitable air cushions [risers] should be installed in supply lines to prevent "hammering." Refer to *Figure 17*.

Connect machine to a backflow preventer (vacuum breaker) before connecting to the public water main in all countries where local regulations require specific water approval certificates.

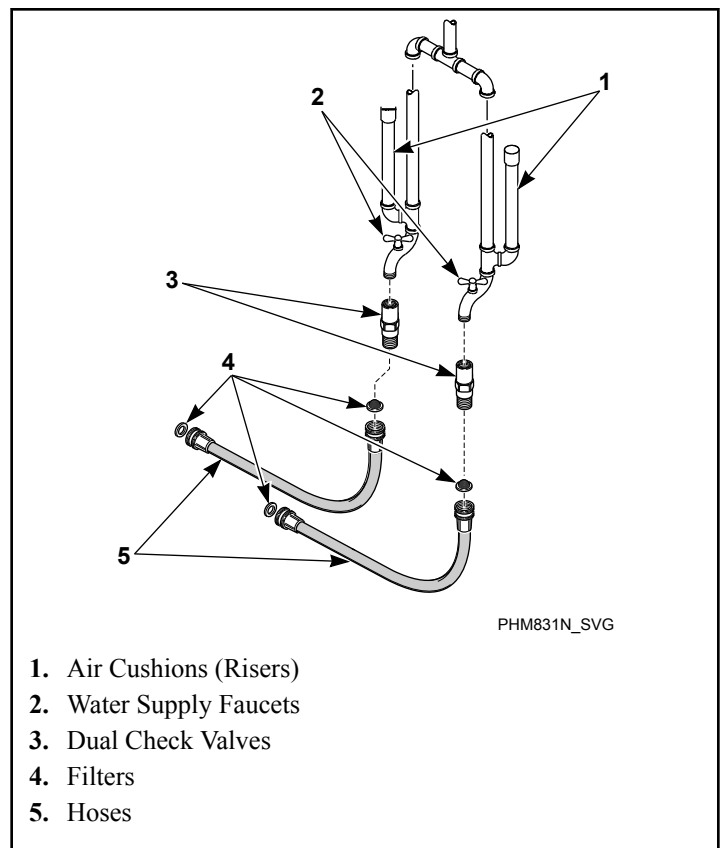

Figure 17

Water Supply Line Sizing			
Models	Number of Machines	Supply Line Size, in. [mm]	
		Main	Hot/Cold
45-65	1	1.25 [32]	1 [25]
	2	2 [50]	1.25 [32]
	3	2 [50]	1.5 [38]
	4	2.5 [64]	2 [50]
85-105	1	1.5 [40]	1 [25]
	2	2 [50]	1.5 [40]
	3	2.5 [65]	2 [50]
	4	3 [80]	2 [50]

Table 18 continues...

<b>Water Supply Line Sizing</b>			
<b>Models</b>	<b>Number of Machines</b>	<b>Supply Line Size, in. [mm]</b>	
		<b>Main</b>	<b>Hot/Cold</b>
<b>130-160</b>	1	2 [50]	1.25 [32]
	2	2.5 [65]	2 [50]
	3	3 [80]	2 [50]
	4	3.5 [90]	2.5 [65]

Table 18

# Plumbing Diagrams

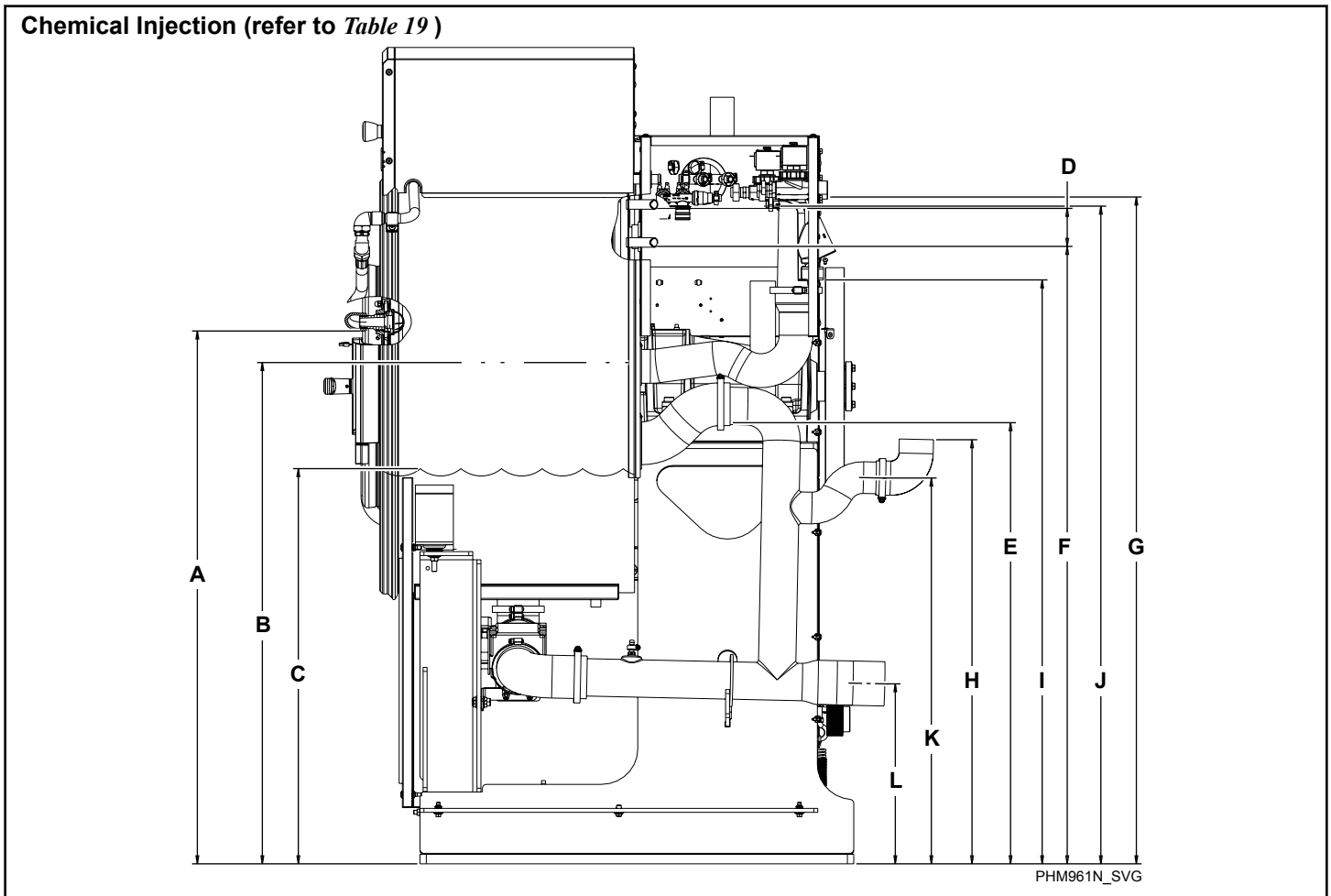

Figure 18

Plumbing Diagram - Chemical Injection, in. [mm]							
Description		45	65	85	105	130	160
A	Lowest point of door spray inlet (UniLine)	42.05 [1068]	42.05 [1068]	45 [1143]	45 [1143]	50.64 [1286]	50.62 [1286]
B	Maximum overflow	39.56 [1005]	39.56 [1005]	42.13 [1070]	42.13 [1070]	41.94 [1091]	41.94 [1091]
C	High fill water level	31.19 [792]	31.19 [792]	31.42 [798]	31.42 [798]	33.74 [857]	33.74 [857]
D	Upper inlet	3 [76]	3 [76]	3.02 [77]	3 [76]	3.6 [91]	3.6 [91]
E	Overflow spill	34.82 [884]	34.82 [884]	35.27 [896]	35.21 [894]	38.8 [986]	38.76 [985]
F	Main fill lower inlet port	48.73 [1238]	48.73 [1238]	52.31 [1329]	52.33 [1329]	57.74 [1467]	57.76 [1467]
G	Inlet valve	52.63 [1337]	52.63 [1337]	57.54 [1462]	57.54 [1462]	64.51 [1639]	64.51 [1639]

Table 19 continues...

Plumbing Diagram - Chemical Injection, in. [mm]							
Description		45	65	85	105	130	160
H	Top of overflow outlet (optional)	33.47 [850]	33.48 [850]	34.18 [868]	34.18 [868]	32.9 [836]	32.9 [836]
I	Chemical dispenser air gap	46.09 [1171]	46.09 [1171]	50.63 [1286]	50.63 [1286]	57.6 [1463]	57.6 [1463]
J	Dispenser fill inlet	51.91 [1319]	51.91 [1319]	56.44 [1434]	56.44 [1434]	63.41 [1611]	63.41 [1611]
K	Center of overflow outlet	30.45 [773]	30.45 [773]	30.74 [781]	30.74 [781]	29.47 [749]	29.47 [749]
L	Center of drain outlet	14.2 [361]	14.2 [361]	12.24 [311]	12.24 [311]	12.21 [310]	12.21 [310]

Table 19

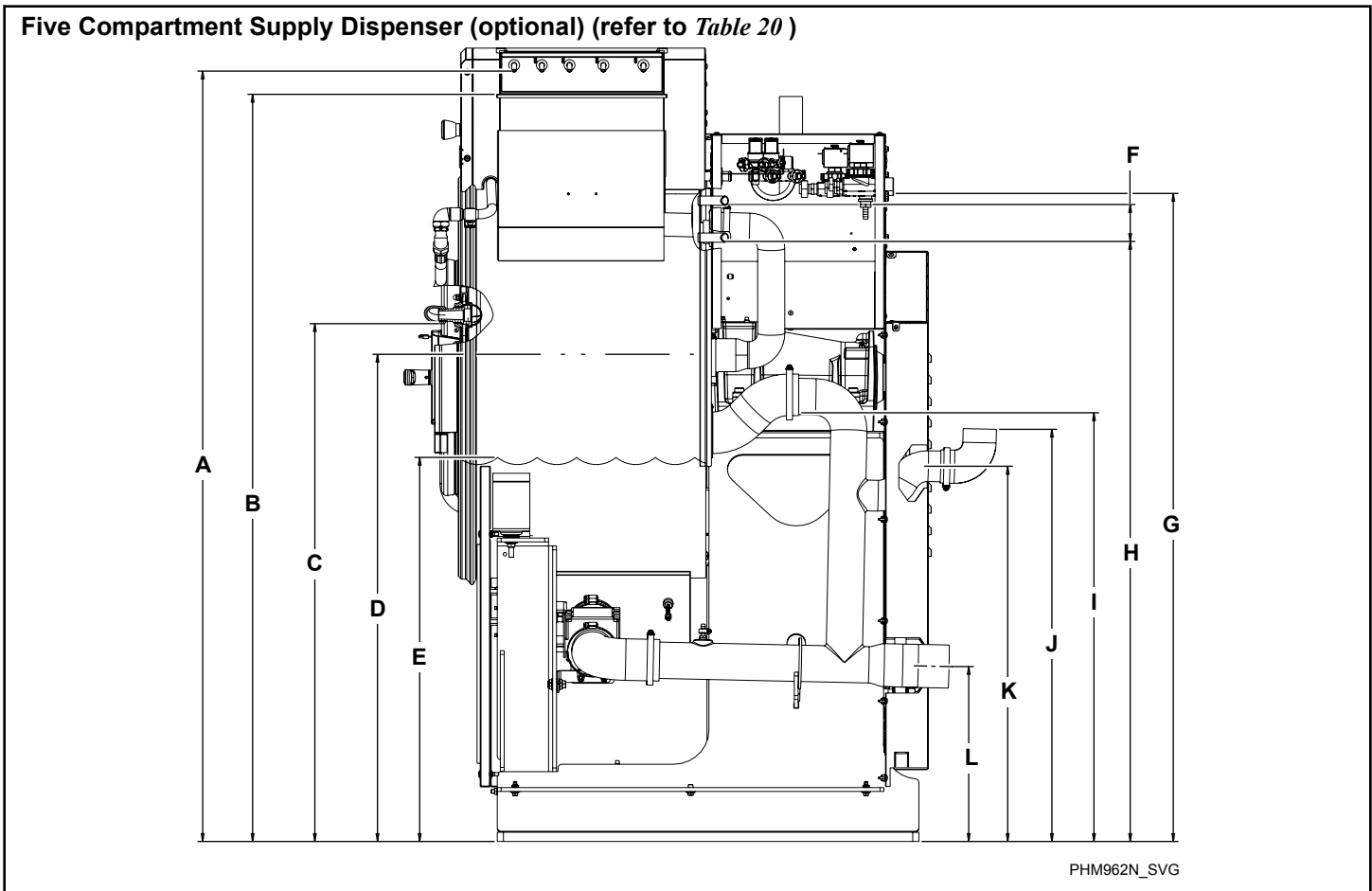



Figure 19

Plumbing Diagram - Five Compartment Supply Dispenser, in. [mm]							
Description		45	65	85	105	130	160
A	Dispenser inlet ports	62.57 [1589]	62.57 [1589]	65.57 [1665]	65.57 [1665]	70.5 [1791]	70.63 [1794]
B	Dispenser spill	60.68 [1541]	60.68 [1541]	63.63 [1616]	63.63 [1616]	68.93 [1751]	68.69 [1751]
C	Lowest point of door spray inlet (UniLinc)	42.05 [1068]	42.05 [1068]	45 [1143]	45 [1143]	50.64 [1286]	50.62 [1286]
D	Maximum overflow	39.56 [1005]	39.56 [1005]	42.13 [1070]	42.13 [1070]	41.94 [1065]	41.94 [1065]
E	High fill water level	31.19 [792]	31.19 [792]	31.42 [798]	31.42 [798]	33.74 [857]	33.74 [857]
F	Upper inlet	3 [76]	3 [76]	3 [76]	3 [76]	3.6 [91]	3.6 [91]
G	Inlet valve	52.63 [1337]	52.63 [1337]	57.54 [1462]	57.54 [1462]	64.51 [1639]	64.51 [1639]
H	Main fill lower inlet port	48.73 [1238]	48.73 [1238]	52.31 [1329]	52.33 [1329]	57.74 [1467]	57.76 [1467]
I	Overflow spill	34.82 [884]	34.82 [884]	35.27 [896]	35.21 [894]	38.8 [986]	38.76 [985]
J	Top of overflow outlet (optional)	33.47 [850]	33.48 [850]	34.18 [868]	34.18 [868]	32.9 [836]	32.9 [836]
K	Center of overflow outlet	30.45 [773]	30.45 [773]	30.74 [781]	30.74 [781]	29.47 [749]	29.47 [749]
L	Center of drain outlet	14.2 [361]	14.2 [361]	12.24 [311]	12.24 [311]	12.21 [310]	12.21 [310]

Table 20

## Electrical Installation Requirements

**IMPORTANT: Electrical ratings are subject to change. Refer to serial decal for electrical ratings information specific to your machine.**

	<b>DANGER</b>
<p><b>Electrical shock hazard will result in death or serious injury. Disconnect electric power and wait five (5) minutes before servicing.</b></p>	
W810	

	<b>WARNING</b>
<p><b>Dangerous voltages are present inside the machine. Only qualified personnel should attempt adjustments and troubleshooting. Disconnect power from the machine before removing any cover and guards, and before attempting any service procedures.</b></p>	
W736	

	<b>WARNING</b>
<p><b>Hazardous Voltage. Can cause shock, burn or death. Verify that a ground wire from a proven earth ground is connected to the lug near the input power block on this machine.</b></p>	
W360	

**NOTE: For voltages above or below listed specification, a qualified electrical contractor must be consulted to install the appropriate transformer to meet the OEM electrical specifications. Refer to *North American Approval and CE Approval*.**

Electrical connections are made at the rear of the machine. The machine must be connected to the proper electrical supply shown on the identification plate attached to the rear of the machine, using copper conductors only.

**IMPORTANT: Alliance Laundry Systems warranty does not cover components that fail as a result of improper input voltage.**

AC inverter drives require a clean power supply free from voltage spikes and surges. Use voltage monitor to check incoming power.

The following conditions require corrective action, contact the local utility to adjust the voltage.

- If the local utility cannot adjust the input voltage, install a buck-boost transformer to lower the input voltage.

- Input voltage is above 240V or 480V, phase to ground voltage exceeds 125% of normal line to line voltage, or 240V open delta configuration (stinger leg). Contact the distributor or the manufacturer for assistance.

On variable-speed models, the inverter drive provides thermal overload protection for the drive motor. However, a separate three-phase circuit breaker must be installed for complete electrical overload protection. This prevents damage to the motor by disconnecting all legs if one should be lost accidentally. Check the nameplate on the back of the machine for recommended circuit breaker requirements size.

**IMPORTANT: Do NOT use fuses in place of a circuit breaker.**

	<b>CAUTION</b>
<p><b>Do not use a phase adder on any variable-speed machine.</b></p>	
SW037	

The machine should be connected to an individual branch circuit not shared with lighting or other equipment.

The connection should be shielded in a liquid-tight or approved flexible conduit with proper conductors of correct size installed in accordance with the National Electric Code or other applicable codes. The connection must be made by a qualified electrician using the wiring diagram provided with the machine, or according to accepted European standards for equipment labeled with the CE mark.

Refer to serial plate for recommended circuit breaker size and determine wire size based on local code requirements.

Refer to serial plate for recommended circuit breaker size and determine wire sizes for runs up to 50 feet [15.24 meters]. Use next larger size for runs of 50 to 100 feet [15.24 to 30.48 meters]. Use 2 sizes larger for runs greater than 100 feet [30.48 meters].

For personal safety and for proper operation, the machine must be grounded in accordance with state and local codes. If such codes are not available, grounding must conform with the National Electric Code, article 250 [current edition] or accepted European standards for equipment labeled with the CE mark. The ground connection must be made to a proven earth ground, not to conduit or water pipes. Refer to *Figure 20* and *Figure 21*.

	<b>WARNING</b>
<p><b>Electrically heated machines DO NOT require dual power sources. Do not connect customer power or customer load to the Internal Load Distribution terminal block. Refer to the machine electrical schematic for details.</b></p>	
W759	

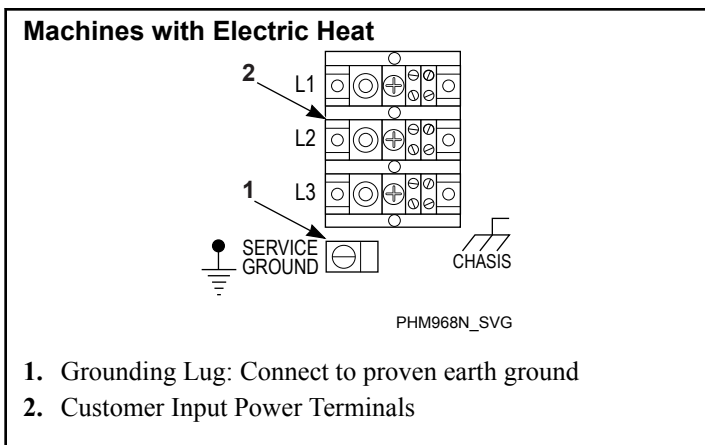

Figure 20

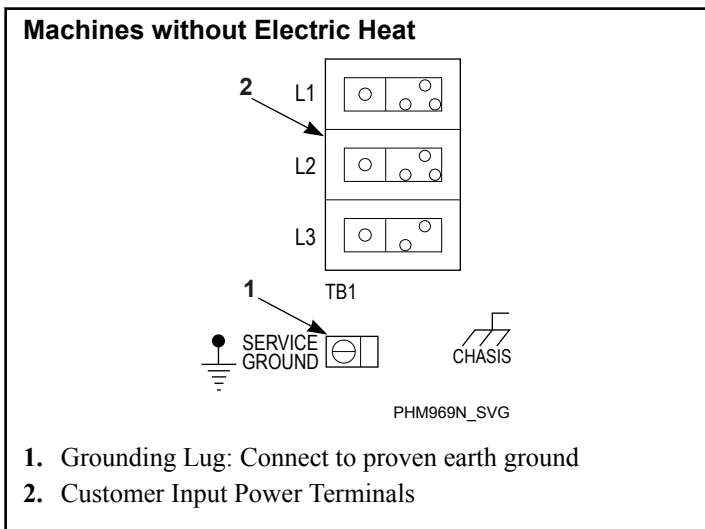

Figure 21

**North American Approval**

Machines can be converted for 50 Hz operation. Refer to conversion label by nameplate for details.

**NOTE: \*Wire sizing listed in this table is based on Article 310, Table 310.16 of the NEC; at 104°F [40°C] ambient temperature. Follow your local electrical codes. Use only copper conductors, rated for 194°F [90°C] or higher, type THHN or better. No more than three current carrying conductors per raceway. Contact your local Authority having jurisdiction if you have questions. Circuit breakers should be UL 489 listed or better. Single phase circuit breakers for single phase machines only; three phase circuit breakers for all others.**

45 Pound [20.4 Kg] Capacity Models - North American Approval									
Voltage Designation					Specifications				
Codes		Voltage	Cycle	Phase	Wire	Full Load Amps	Circuit Breaker	AWG*	mm <sup>2</sup> *
<b>L-Speed Models</b>									
X		200–208/ 220-240	50-60	1/3	2/3	8/6	15	14	2.5
<b>M-Speed Models</b>									
X		200–208/ 220-240	50-60	1/3	2/3	11/8	15	14	2.5
Q	Electric Heat	200–208/ 220-240	50-60	3	3	71	80	4	25.0
N	Standard	440-480	50-60	3	3	5	15	14	2.5
	Electric Heat					36	40	8	10.0
P	Standard	380-415	50-60	3	3	6	15	14	2.5
	Electric Heat					32	40	8	10.0
<b>V-Speed Models</b>									
X		200–208/ 220-240	50-60	1/3	2/3	15/9	20/15	12/14	4.0/ 2.5
Q	Electric Heat	200–208/ 220-240	50-60	3	3	71	80	4	25.0
N	Standard	440-480	50-60	3	3	6	15	14	2.5
	Electric Heat					36	40	8	10.0

Table 21 continues...

45 Pound [20.4 Kg] Capacity Models - North American Approval									
Voltage Designation					Specifications				
Codes		Voltage	Cycle	Phase	Wire	Full Load Amps	Circuit Breaker	AWG*	mm <sup>2</sup> *
P	Standard	380-415	50-60	3	3	7	15	14	2.5
	Electric Heat					32	40	8	10.0

Table 21

65 Pound [29.5 Kg] Capacity Models - North American Approval									
Voltage Designation					Specifications				
Codes		Voltage	Cycle	Phase	Wire	Full Load Amps	Circuit Breaker	AWG*	mm <sup>2</sup> *
<b>L-Speed Models</b>									
X		200–208/ 220-240	50-60	1/3	2/3	12/7	15	14	2.5
<b>M-Speed Models</b>									
X		200–208/ 220-240	50-60	1/3	2/3	16/9	20/15	12/14	4.0/ 2.5
Q	Electric Heat	200–208/ 220-240	50-60	3	3	71	80	4	25.0
N	Standard	440-480	50-60	3	3	6	15	14	2.5
	Electric Heat					37	40	8	10.0
P	Standard	380-415	50-60	3	3	7	15	14	2.5
	Electric Heat					33	40	8	10.0
<b>V-Speed Models</b>									
X		200–208/ 220-240	50-60	1/3	2/3	16/10	20/15	12/14	4.0/ 2.5
Q	Electric Heat	200–208/ 220-240	50-60	3	3	71	80	4	25.0
N	Standard	440-480	50-60	3	3	7	15	14	2.5
	Electric Heat					37	40	8	10.0
P	Standard	380-415	50-60	3	3	8	15	14	2.5
	Electric Heat					33	40	8	10.0

Table 22

85 Pound [38.6 Kg] Capacity Models - North American Approval									
Voltage Designation					Specifications				
Codes		Voltage	Cycle	Phase	Wire	Full Load Amps	Circuit Breaker	AWG*	mm <sup>2</sup> *
<b>M-Speed Models</b>									
Q	Standard	200–208/ 220-240	50-60	3	3	14	20	12	4
	Electric Heat					105	110	2	35
N	Standard	440-480	50-60	3	3	9	15	14	2.5
	Electric Heat					39	40	8	10
P	Standard	380-415	50-60	3	3	9	15	14	2.5
	Electric Heat					35	40	8	10
<b>V-Speed Models</b>									
Q	Standard	200–208/ 220-240	50-60	3	3	16	20	12	4
	Electric Heat					105	110	2	35
N	Standard	440-480	50-60	3	3	10	15	14	2.5
	Electric Heat					39	40	8	10
P	Standard	380-415	50-60	3	3	10	15	14	2.5
	Electric Heat					35	40	8	10

Table 23

105 Pound [47.6 Kg] Capacity Models - North American Approval									
Voltage Designation					Specifications				
Codes		Voltage	Cycle	Phase	Wire	Full Load Amps	Circuit Breaker	AWG*	mm <sup>2</sup> *
<b>M-Speed Models</b>									
Q	Standard	200–208/ 220-240	50-60	3	3	14	20	12	4
	Electric Heat					108	110	2	35
N	Standard	440-480	50-60	3	3	9	15	14	2.5
	Electric Heat					40	50	8	10
P	Standard	380-415	50-60	3	3	9	15	14	2.5
	Electric Heat					36	40	8	10
<b>V-Speed Models</b>									
Q	Standard	200–208/ 220-240	50-60	3	3	16	20	12	4
	Electric Heat					108	110	2	35
N	Standard	440-480	50-60	3	3	10	15	14	2.5
	Electric Heat					40	50	8	10
P	Standard	380-415	50-60	3	3	10	15	14	2.5
	Electric Heat					36	40	8	10

Table 24

130 Pound [59 Kg] Capacity Models - North American Approval									
Voltage Designation					Specifications				
Codes	Voltage	Cycle	Phase	Wire	Full Load Amps	Circuit Breaker	AWG*	mm <sup>2</sup> *	
<b>M-Speed Models</b>									
Q	200–208/ 220-240	50-60	3	3	16	20	12	4	
N	440-480	50-60	3	3	10	15	14	2.5	
P	380-415	50-60	3	3	10	15	14	2.5	
<b>V-Speed Models</b>									
Q	200–208/ 220-240	50-60	3	3	21	30	10	6	
N	Standard	440-480	50-60	3	3	12	15	14	2.5
	Electric Heat					74	80	4	25
P	Standard	380-415	50-60	3	3	12	15	14	2.5
	Electric Heat					65	70	4	25

Table 25

160 Pound [72.6 Kg] Capacity Models - North American Approval								
Voltage Designation						Specifications		
Codes	Voltage	Cycle	Phase	Wire	Full Load Amps	Circuit Breaker	AWG*	mm <sup>2</sup> *
<b>V-Speed Models</b>								
Q	200-208/ 220-240	50-60	3	3	22	30	10	6
N	440-480	50-60	3	3	12	15	14	2.5
P	380-415	50-60	3	3	12	15	14	2.5

Table 26

**CE Approval**

Machines can be converted for 50 Hz operation. Refer to conversion label by nameplate for details.

**NOTE: \*Wire sizing listed in this table is based on Article 310, Table 310.16 of the NEC; at 104°F [40°C] ambient temperature. Follow your local electrical codes. Use only copper conductors, rated for 194°F [90°C] or higher, type THHN or better. No more than three current carrying conductors per raceway. Contact your local Authority having jurisdiction if you have questions. Circuit breakers should be UL 489 listed or better. Single phase circuit breakers for single phase machines only; three phase circuit breakers for all others.**

45 Pound [20.4 Kg] Capacity Models - CE Approval								
Voltage Designation					Specifications			
Code		Voltage	Cycle	Phase	Wire	Full Load Amps	Circuit Breaker	mm <sup>2</sup> *
<b>L-Speed Models</b>								
X		200-208/ 220-240	50-60	1/3	2/3	11/7	16/10	2.5
<b>M-Speed Models</b>								
X		200-208/ 220-240	50-60	1/3	2/3	11/8	16/10	2.5
Q	Electric Heat	200-208/ 220-240	50-60	3	3	71	80	25
N	Standard	440-480	50-60	3	3	7	10	2.5
	Electric Heat					36	40	10
P	Standard	380-415	50-60	3	3	7	10	2.5
	Electric Heat					32	40	10
<b>V-Speed Models</b>								
X		200-208/ 220-240	50-60	1/3	2/3	17/11	20/16	2.5
Q	Electric Heat	200-208/ 220-240	50-60	3	3	71	80	25
N	Standard	440-480	50-60	3	3	7	10	2.5
	Electric Heat					36	40	10
P	Standard	380-415	50-60	3	3	7	10	2.5
	Electric Heat					32	40	10

Table 27

65 Pound [29.5 Kg] Capacity Models - CE Approval								
Voltage Designation					Specifications			
Code		Voltage	Cycle	Phase	Wire	Full Load Amps	Circuit Breaker	mm <sup>2</sup> *
<b>L-Speed Models</b>								
X		200-208/ 220-240	50-60	1/3	2/3	12/7	16/10	2.5
<b>M-Speed Models</b>								
X		200-208/ 220-240	50-60	1/3	2/3	17/9	20/10	2.5
Q	Electric Heat	200-208/ 220-240	50-60	3	3	71	80	25
N	Standard	440-480	50-60	3	3	7	10	2.5
	Electric Heat					37	40	10
P	Standard	380-415	50-60	3	3	7	10	2.5
	Electric Heat					33	40	10
<b>V-Speed Models</b>								
X		200-208/ 220-240	50-60	1/3	2/3	17/11	20/16	2.5
Q	Electric Heat	200-208/ 220-240	50-60	3	3	71	80	25
N	Standard	440-480	50-60	3	3	7	10	2.5
	Electric Heat					37	40	10
P	Standard	380-415	50-60	3	3	8	10	2.5
	Electric Heat					33	40	10

Table 28

85 Pound [38.6 Kg] Capacity Models - CE Approval								
Voltage Designation					Specifications			
Code		Voltage	Cycle	Phase	Wire	Full Load Amps	Circuit Breaker	mm <sup>2</sup> *
<b>M and V-Speed Models</b>								
Q	Standard	200-208/ 220-240	50-60	3	3	17	20	2.5
	Electric Heat					105	125	35
N	Standard	440-480	50-60	3	3	11	16	2.5
	Electric Heat					39	40	10
P	Standard	380-415	50-60	3	3	11	16	2.5
	Electric Heat					35	40	10

Table 29

105 Pound [47.6 Kg] Capacity Models - CE Approval								
Voltage Designation					Specifications			
Code		Voltage	Cycle	Phase	Wire	Full Load Amps	Circuit Breaker	mm <sup>2</sup> *
<b>M and V-Speed Models</b>								
Q	Standard	200-208/ 220-240	50-60	3	3	17	20	2.5
	Electric Heat					108	125	35
N	Standard	440-480	50-60	3	3	11	16	2.5
	Electric Heat					40	40	10
P	Standard	380-415	50-60	3	3	11	16	2.5
	Electric Heat					36	40	10

Table 30

130 Pound [59 Kg] Capacity Models - CE Approval								
Voltage Designation					Specifications			
Code		Voltage	Cycle	Phase	Wire	Full Load Amps	Circuit Breaker	mm <sup>2</sup> *
<b>M-Speed Models</b>								
Q		200-208/ 220-240	50-60	3	3	17	20	2.5
N	Standard	440-480	50-60	3	3	11	16	2.5
	Electric Heat					74	80	16
P	Standard	380-415	50-60	3	3	11	16	2.5
	Electric Heat					65	80	16
<b>V-Speed Models</b>								
Q		200-208/ 220-240	50-60	3	3	21	25	2.5
N	Standard	440-480	50-60	3	3	12	16	2.5
	Electric Heat					74	80	16
P	Standard	380-415	50-60	3	3	12	16	2.5
	Electric Heat					65	80	16

Table 31

160 Pound [72.6 Kg] Capacity Models - CE Approval							
Voltage Designation					Specifications		
Code	Voltage	Cycle	Phase	Wire	Full Load Amps	Circuit Breaker	mm <sup>2</sup> *
<b>V-Speed Models</b>							
Q	200-208/ 220-240	50-60	3	3	22	25	2.5
N	440-480	50-60	3	3	12	16	2.5
P	380-415	50-60	3	3	12	16	2.5

Table 32

## Steam Requirements (Steam Heat Option Only)

	<b>WARNING</b>
<p><b>Hot Surfaces. Will cause severe burns. Turn steam off and allow steam pipes, connections and components to cool before touching.</b></p>	
W505	

For machines equipped with optional steam heat, install piping in accordance with approved commercial steam practices. Steam requirements are shown in *Table 33*.

Steam Supply Information		
Specifications	45-105	130-160
Steam inlet connection, in.	1/2	3/4
Number of steam inlets	1	1
Recommended pressure, psi [kPa]	30-85 [200-570]	30-85 [200-570]
Maximum pressure, psi [kPa]	85 [570]	85 [570]

Table 33

**IMPORTANT:** Failure to install the customer supplied steam filter may void the warranty.

## Chemical Injection Supply System

	<b>WARNING</b>
<p><b>Dangerous Chemicals. May damage eyes and skin. Wear eye and hand protection when handling chemicals; always avoid direct contact with raw chemicals. Read the manufacturer's directions for accidental contact before handling chemicals. Ensure an eye-rinse facility and an emergency shower are within easy reach. Check at regular intervals for chemical leaks.</b></p>	
W363	

**IMPORTANT:** Undiluted chemical dripping can damage the machine. Therefore, all chemical injector supply dispenser pumps and dispenser tubing should be mounted below the machine's injection point. Loops do not prevent drips if these instructions are not followed. *Figure 23* shows a typical Chemical Injection Supply System. *Figure 26* shows a typical Five Compartment Supply System.

**IMPORTANT:** Failure to follow these instructions could damage the machine and void the warranty.

The chemical supply connector is located on the back of the machine. There are six outer ports in this connector (7 on connectors made before July 2013), through each a liquid supply hose can be connected, and one water flush port located in the center of the connector.

Outer ports must be drilled through with a 3/16 inch diameter drill bit and center port must be drilled through with a 1/2 inch diameter drill bit before connecting chemical lines. Refer to *Figure 22*.

	<b>CAUTION</b>
<p><b>Drill out plugs and nipples before making supply hose connection. Failure to do so can cause buildup of pressure and risk a tubing rupture.</b></p>	
W491	

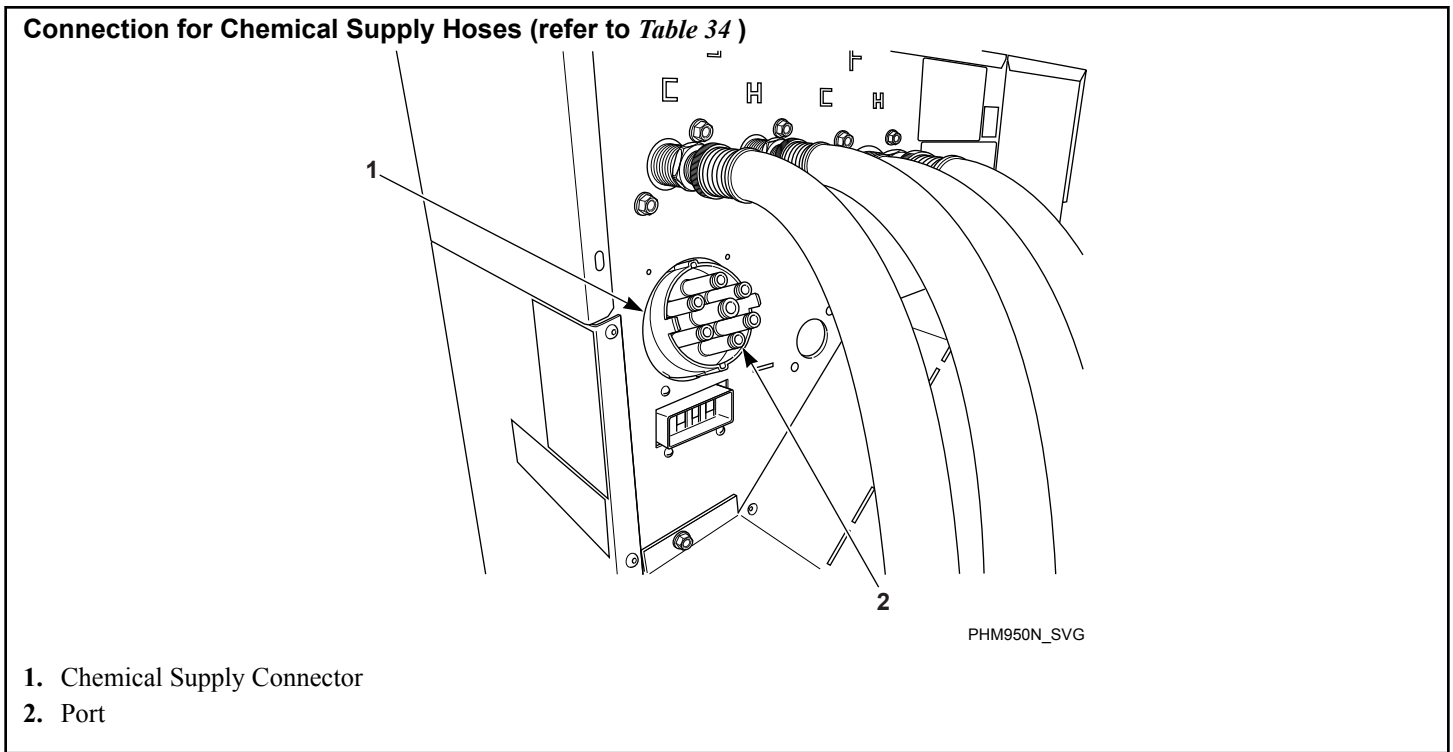
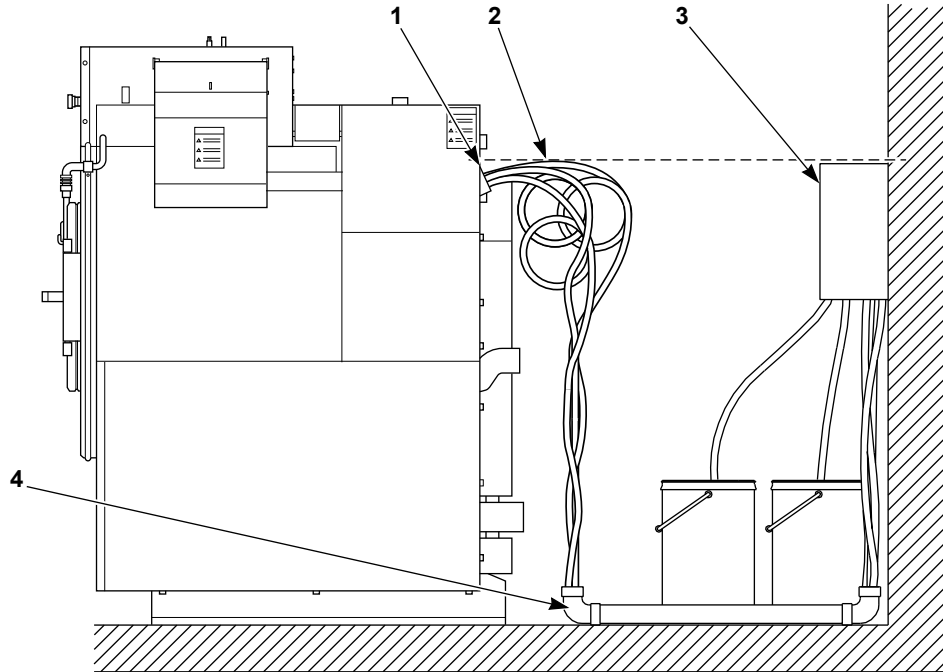

Figure 22

<b>Chemical Injection Supply System</b>	
Number of external liquid supply connections	6
Number of chemical flush connections	1
Liquid supply connection size OD, in. [mm]	5/8 [15.9]

Table 34

**Chemical Supply Setup Using Rear Ports**



PHM939N\_SVG1

\* Use a check valve on the end of tubing

† Pumps must be mounted below the injection point

- 1. Injection Point\*
- 2. Loops
- 3. Chemical Dispenser Pump Outlet †
- 4. PVC Pipe

Figure 23

**Flush Manifold Systems**

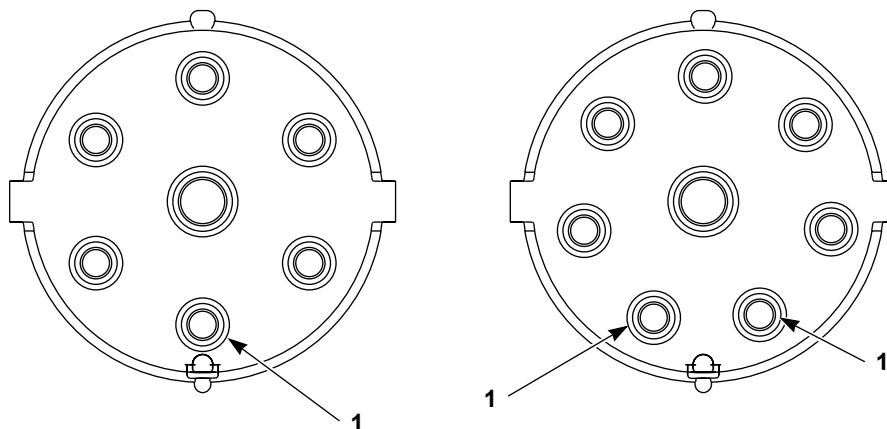

PHM964N\_SVG1

- 1. It is possible to use the bottom-most port for connecting a flush manifold system. Water pressure must not exceed 30 psi.

Figure 24

### Connecting External Liquid Supplies with Five Compartment Supply Dispenser (Optional)

#### Five Compartment Supply Dispenser (Optional)

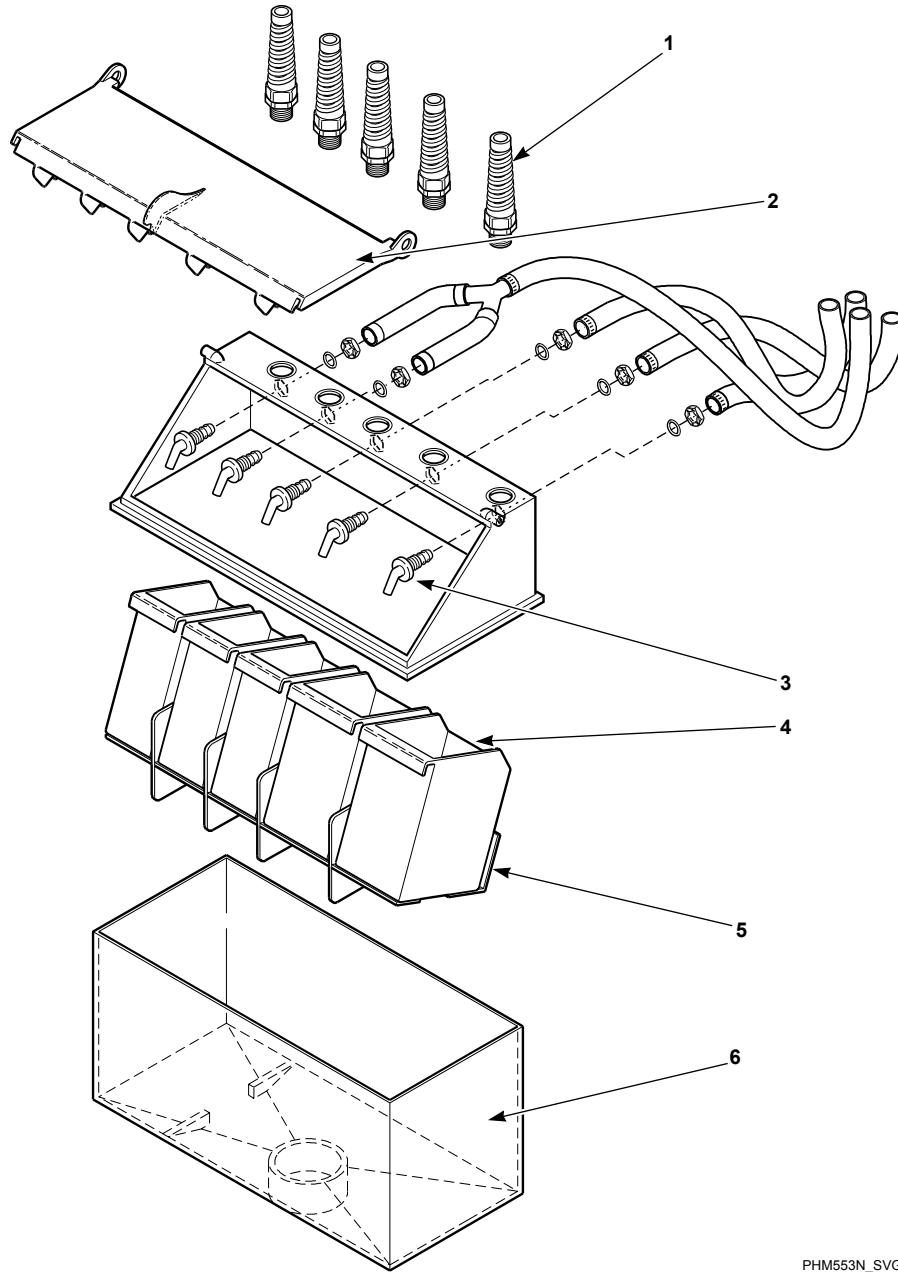

PHM553N\_SVG

**IMPORTANT: Do not attach anything to nozzles. Air gap must be maintained.**

1. Strain Relief for Liquid Chemical Supply Lines
2. Supply Dispenser Lid
3. Nozzles
4. Dry Supply Cups
5. Dry Supply Insert
6. Polypropylene Supply Dispenser

Figure 25

1. Remove knockout from supply dispenser. Refer to *Figure 25*. Plugs are assembled inside the tubing ring.
2. Install PG connector in hole with strain reliefs, included in the seal nut.
3. Insert tubes through PG base. Do not remove cups. Tube should extend into the plastic cup, with the exception of the softener tube, which should be routed to the outside of the cup.
4. Tighten the seal nut to prevent tubing from escaping the assembly.
5. Before operating machine, confirm lid is completely closed.

Do not attempt to make chemical injection electrical connections to points other than those provided specifically for that purpose by the factory.

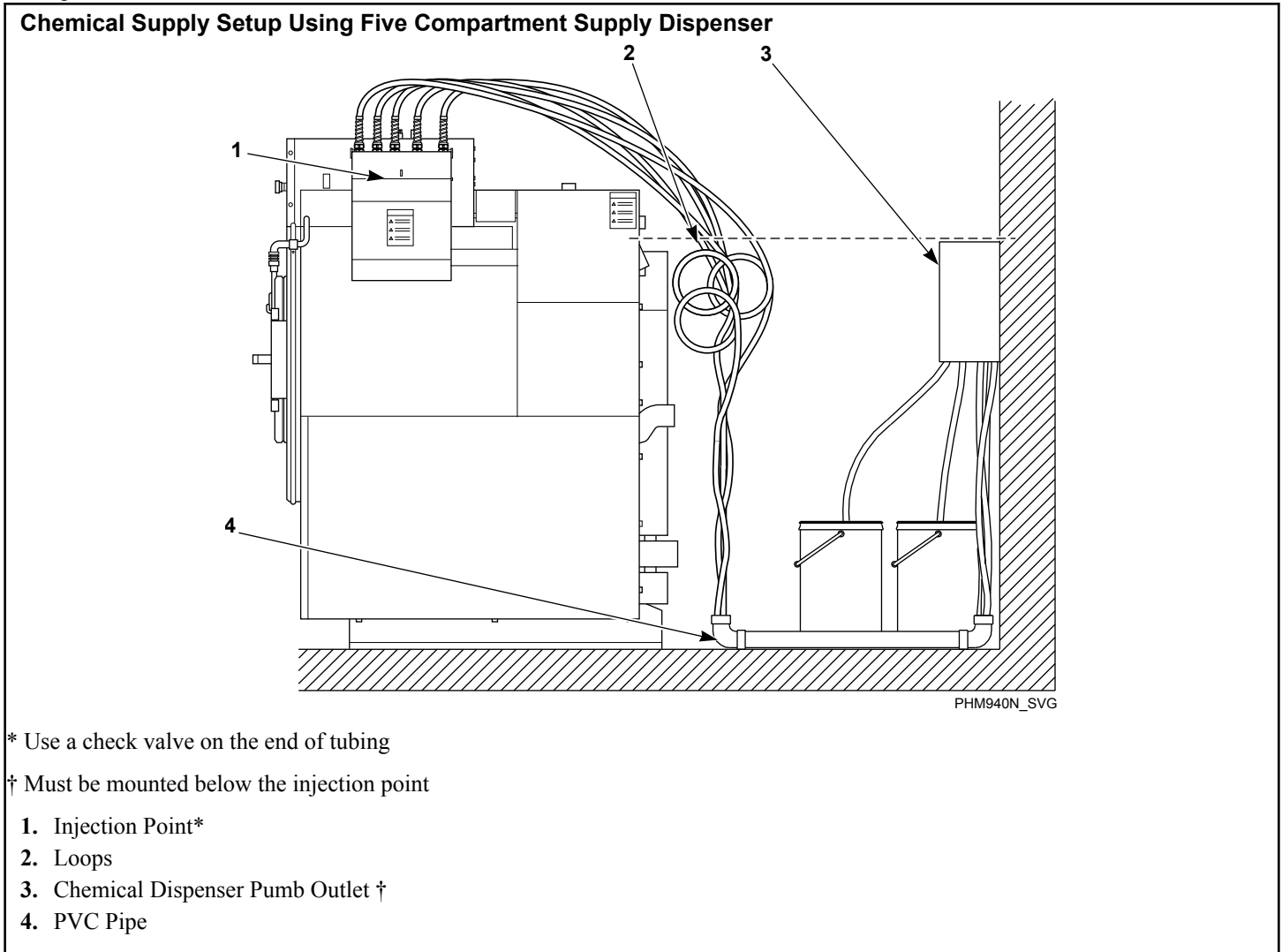

Figure 26

## External Supplies

For proper communication between the machine and an external chemical supply system, it is important for the low-voltage signal power to be connected properly. The included wiring diagram shows several different options for safe and correct wiring of this interface.

The preferred method for connecting the wiring from the external chemical supply system to the machine is to use the 300mA power of the machine's 24VAC control transformer, which is intended strictly for this purpose. Other voltage and current options are

available, but require some wiring changes and must be provided with an external power source. Under no circumstances should the high-voltage machine supply connections or source be used for the communication wiring.

Communication wiring connections, which include a single row of identified terminal blocks, can be found under a service panel at the upper back of the machine.

### Chemical Injection Using Internal 24VAC Control Transformer

**NOTE: Using the Internal 24VAC 300 Milliamp Control Transformer is recommended by Alliance Laundry Systems.**

**IMPORTANT: DO NOT remove the red jumper wire from the terminal strip.**

There are 3 terminals necessary for this connection option.

- Terminal “24VAC COM” is used to connect one side of the internal control transformer to the external dispenser input signals common.
- The second terminal is used to connect the other side of the control transformer to the machine output signals common through a red jumper wire between “24VAC” and “RELAY COM”.

**IMPORTANT: Do not use the transformer terminals if an external power supply is used.**

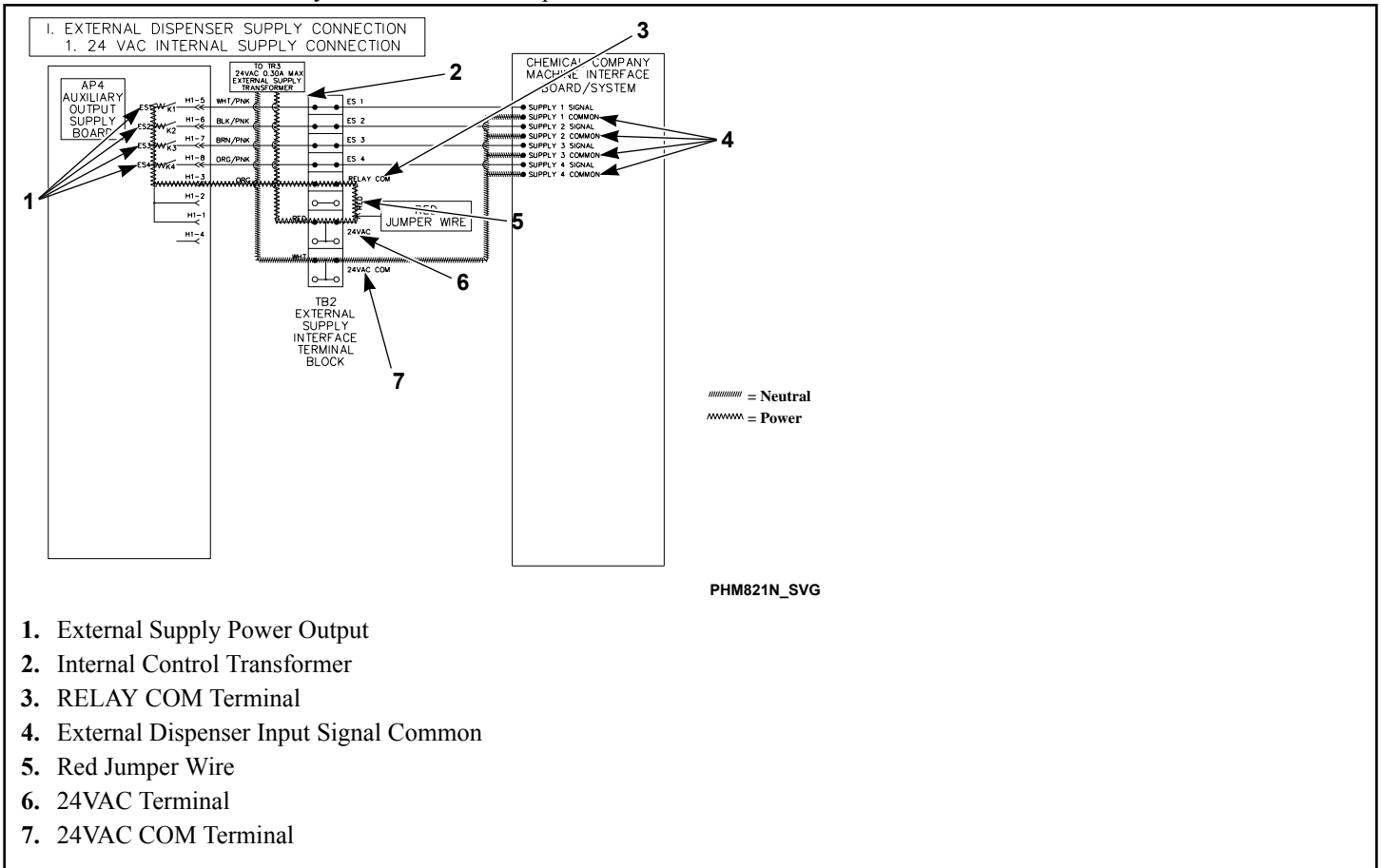

Figure 27

### Chemical Injection Using External AC Power Source

**NOTE: An External AC Power Source is NOT provided by Alliance Laundry Systems.**

**NOTE: Power for external supplies must not be derived from the high-voltage main power connection point.**

**IMPORTANT: The external power must supply power of 240VAC or less and be protected at 3 Amps or less.**

1. Disconnect and cap off the Red and White 24VAC wires.
2. Connect one side of the external power to the “RELAY COM” and the other to the external dispenser input signals common. Refer to *Figure 28*.

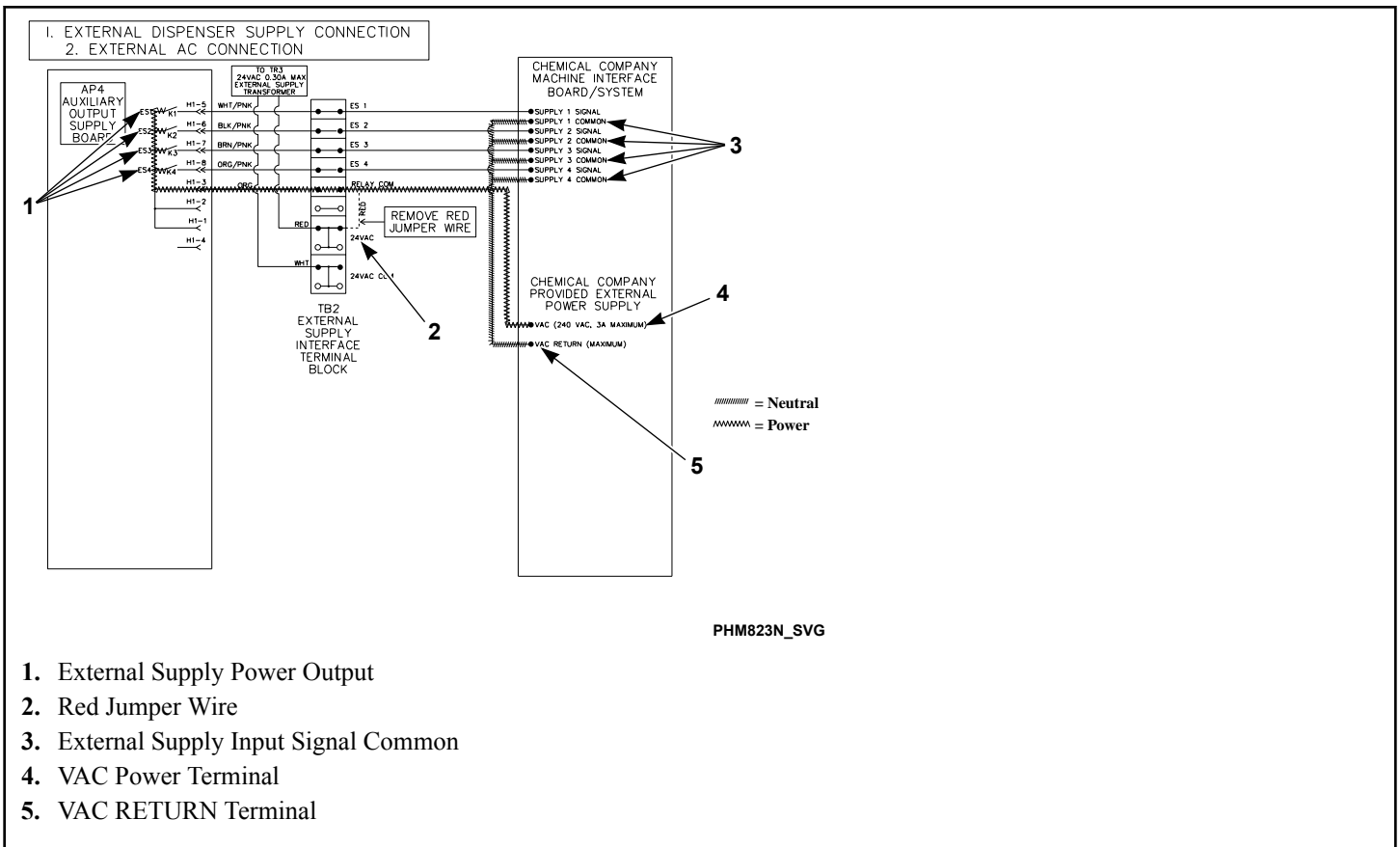

1. External Supply Power Output
2. Red Jumper Wire
3. External Supply Input Signal Common
4. VAC Power Terminal
5. VAC RETURN Terminal

Figure 28

	<b>CAUTION</b>
<p><b>Do not attempt to increase fuse rating or alter wiring of external chemical supply terminal strip in such as way that may conflict with the suggested methods provided on the Optional External Supply Wiring Diagram.</b></p>	
W699	

### External Supply Signals

Wash-cycle signals are provided to the external chemical supply equipment and a “wait for the next step” signal can be received from the supply equipment.

For example, if ES1 is selected the K1 contact will close and power will be supplied to Supply 1 Signal. The contact will remain closed for the amount of time programmed in control. Refer to *Figure 29* for Internal Supply Connection or *Figure 30* for External AC Connection.

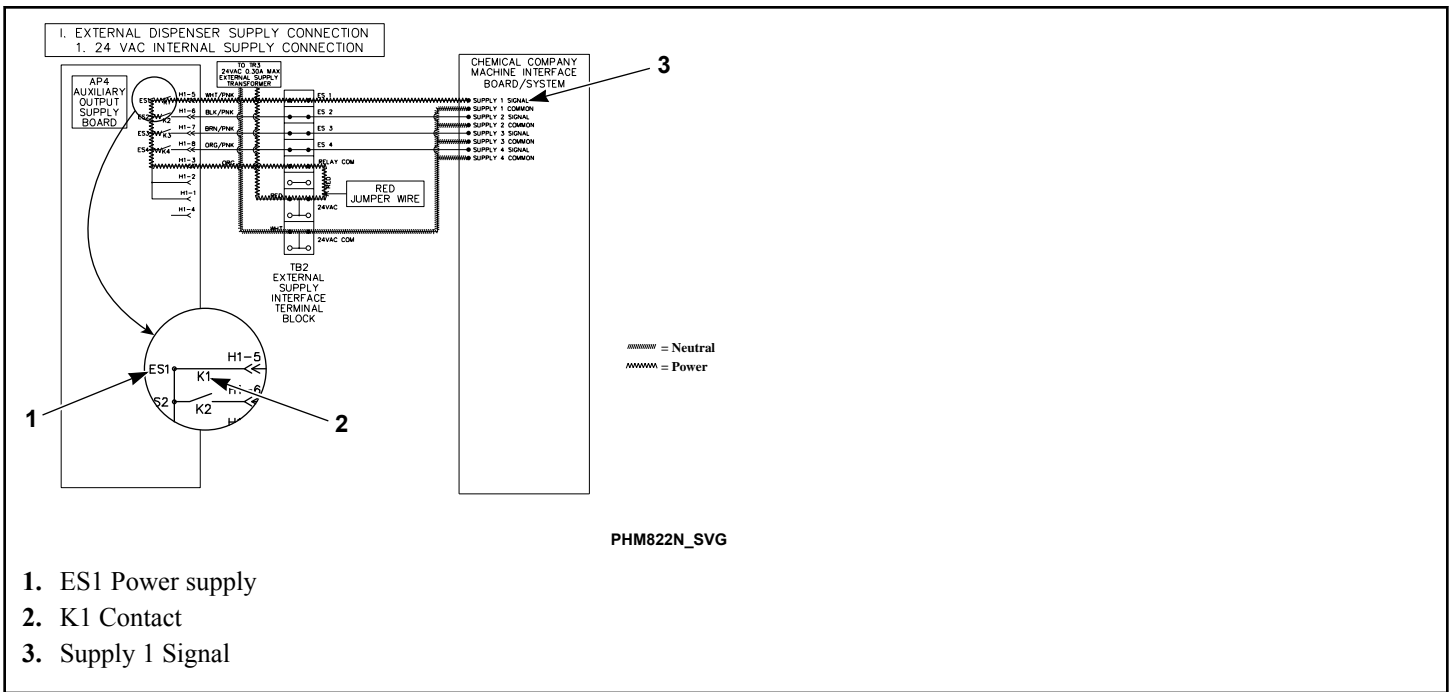

Figure 29

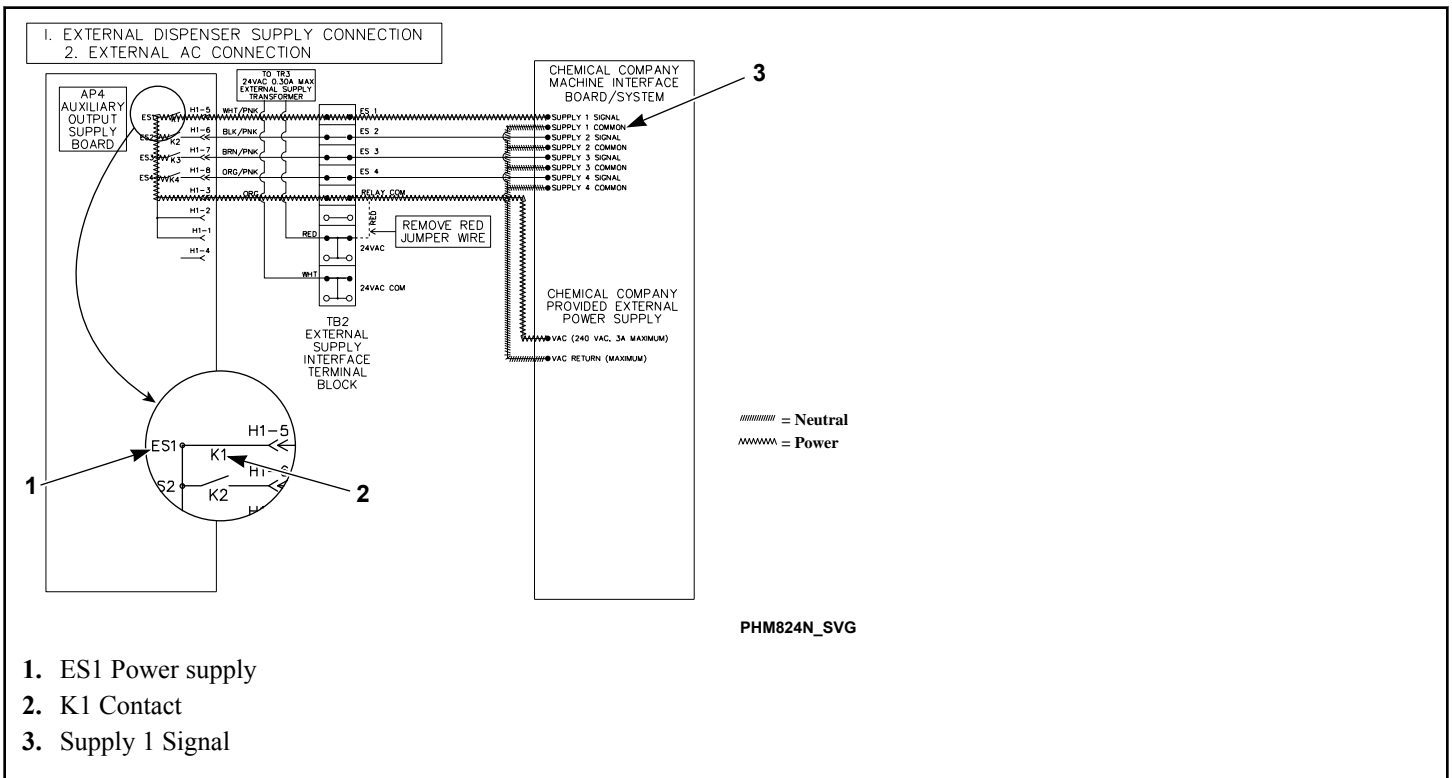

Figure 30

# Operation

## Operating Instructions for UniLinc Control

Underloading can cause out-of-balance conditions that can shorten machine life.

1. Verify display shows the Cycle Menu Screen.

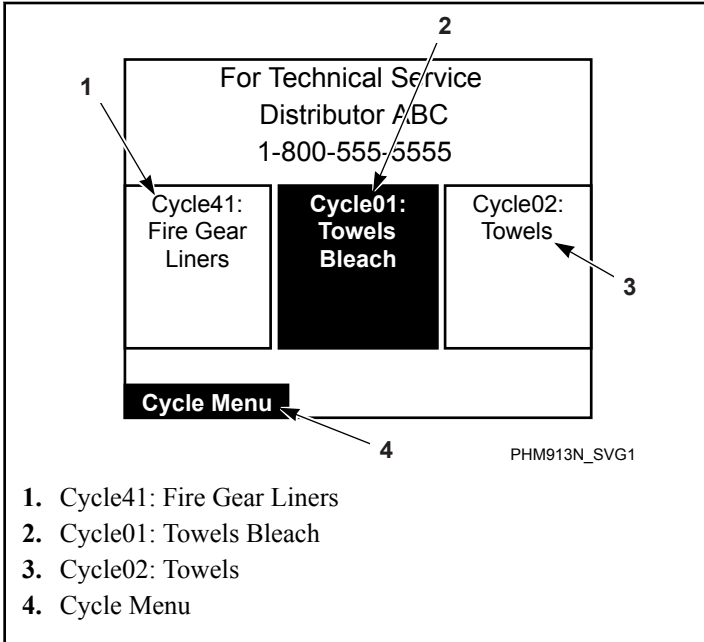

1. Cycle41: Fire Gear Liners
2. Cycle01: Towels Bleach
3. Cycle02: Towels
4. Cycle Menu

Figure 31

2. Turn door handle clockwise and open door.

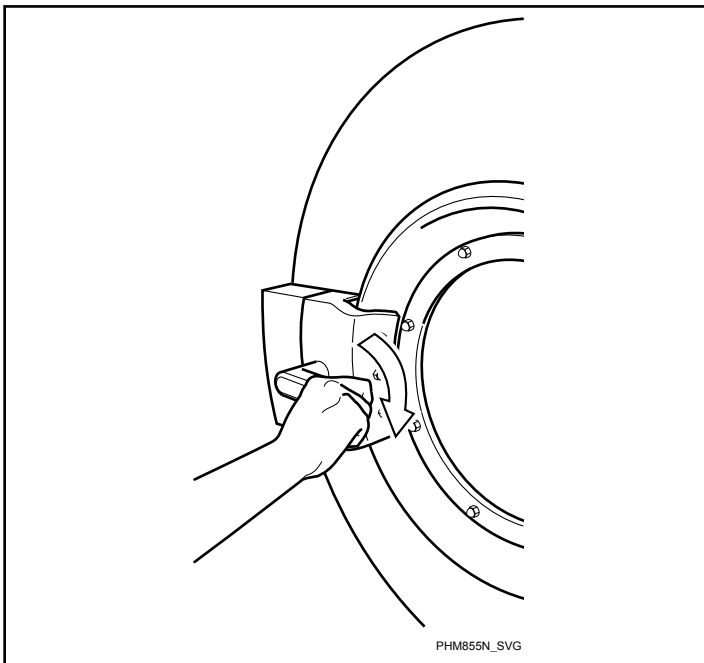

Figure 32

3. Load to capacity whenever possible. DO NOT OVERLOAD.

	<b>CAUTION</b>
<p><b>Be careful around the open door, particularly when loading from a level below the door. Impact with door edges can cause personal injury.</b></p>	
SW025	

	<b>CAUTION</b>
<p><b>Water cannot be extracted from rubber backed items. To avoid damage to machine from out of balance conditions, do not use a spin (extract) step when washing rubber backed items. Warranty will be voided.</b></p>	
W880	

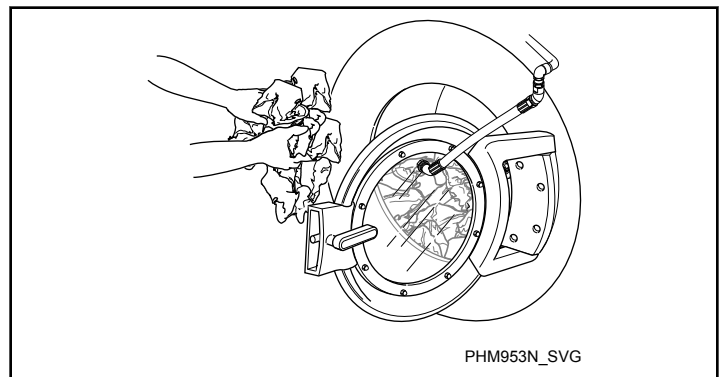

Figure 33

**NOTE:** When washing items which may disintegrate or fragment, such as mop heads or sponges, use laundry nets to prevent drain blockage.

**IMPORTANT:** To prevent out-of-balance conditions, premature wear or damage to machine when using laundry nets, use several small nets in a load.

4. Close the door by rotating the handle counterclockwise. Refer to *Figure 34*.

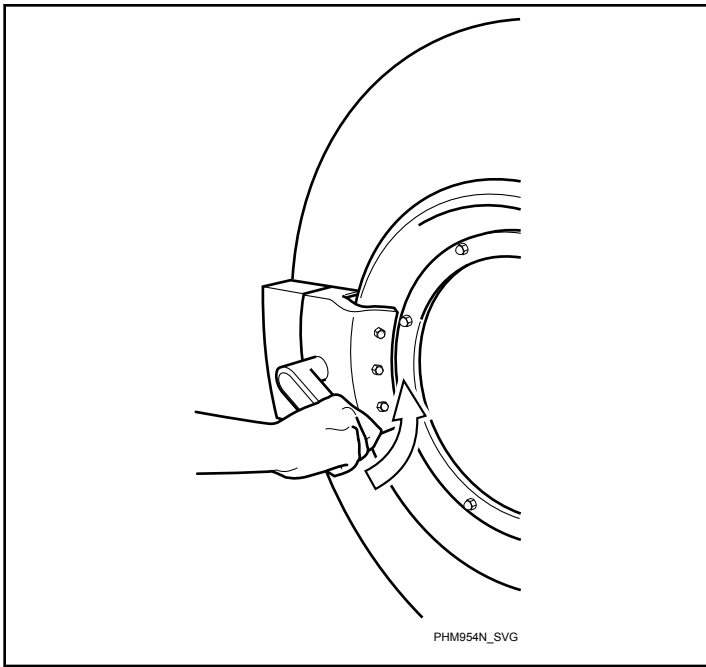



Figure 34

5. If equipped with an optional supply dispenser, add dry supplies to the compartment cups prior to the start of each cycle.

Liquid supplies can be injected directly into the supply dispenser by an external chemical supply system.

**NOTE: Supply dispenser compartment cups must not be removed when an external chemical injection supply system is attached to the machine.**

6. Press  or  keypads to select desired wash cycle.

7. Press  to start the selected cycle.

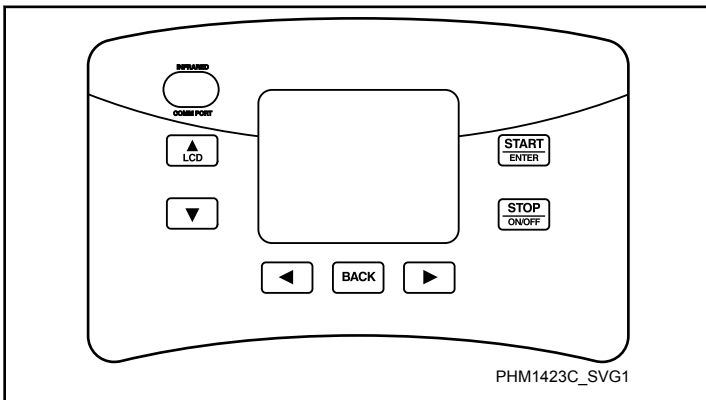



Figure 35

As the cycle proceeds, the display will show a summary of the cycle occurring.

To begin the cycle at any step other than the first step, press the  keypad to advance through the cycle to the desired starting point. Refer to **Programming Manual** for information to disable Rapid Advance.

If the door is open, the display will indicate that the door needs to be closed. Refer to *Figure 36*.

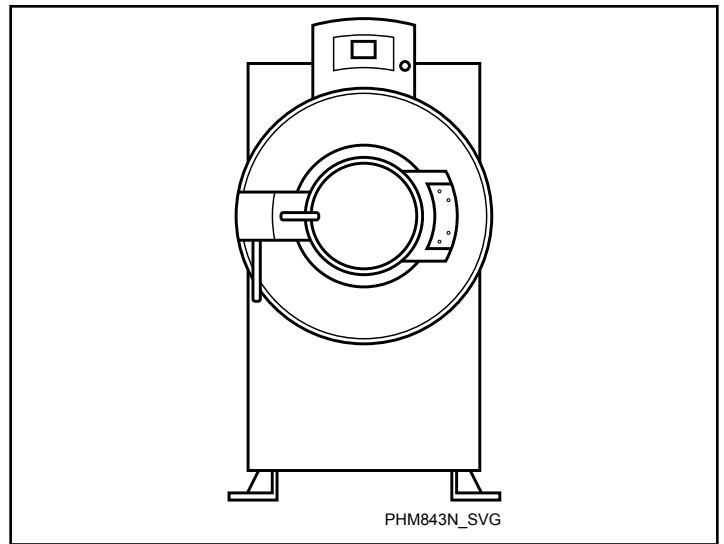



Figure 36

8. Close door to start cycle or press  keypad to return to Cycle Menu. The cycle will continue until its completion. Then the display will show the door is ready to be opened.

**NOTE: Since the machine MUST drain and balance during the drain step before it can extract, the control will only Rapid Advance to a drain step that occurs before an extract or spray rinse extract step.**

9. Emergency stop button (refer to *Figure 37*) should be depressed to terminate machine operation when any unsafe condition is present during machine operation.

- a. Press red emergency stop button to stop all action.
- b. To restart machine, pull red emergency stop button out and press START keypad.

**NOTE: Activation of the emergency stop button stops all machine control circuit functions, but DOES NOT remove all electrical power from machine.**

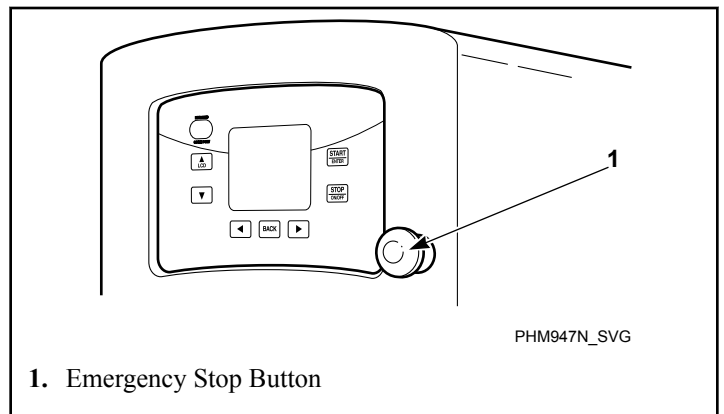

1. Emergency Stop Button

Figure 37

**Shakeout Routine**

	<b>WARNING</b>
<p><b>NEVER</b> insert hands or objects into basket until it has completely stopped. Doing so could result in serious injury.</p>	
SW012	

	<b>WARNING</b>
<p>To avoid personal injury, do <b>NOT</b> reach into the basket while it is rotating. Keep all personnel at a safe distance from the machine while using the Basket Jog Feature.</p>	
W641	

A Shakeout agitation step is programmed at the end of every cycle and will help prevent tangling of the load.

The Shakeout time is set at the factory to agitate for 40 seconds. Refer to **Programming Manual** to disable or change the time of the Shakeout.

**Basket Jog Feature (160 Pound Models Only)**

With the door open and the control in Cycle Menu, press and HOLD both jog buttons with both hands. A series of loud beeps will occur, indicating the jog feature is about to start.

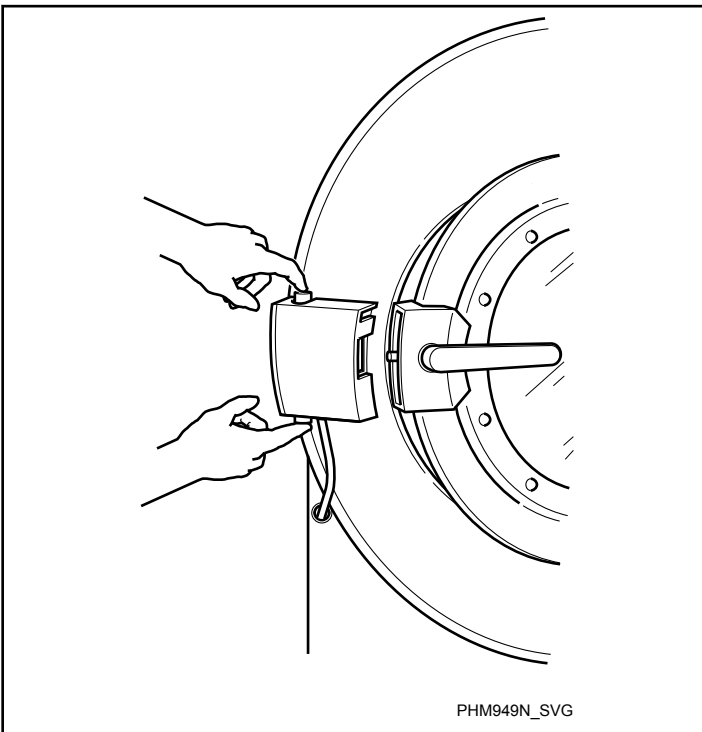

Figure 38

The jog feature is deactivated when the loading door is closed and the jog buttons are not pressed.

# Operating Instructions for M30 Control

1. Verify display shows a cycle number.

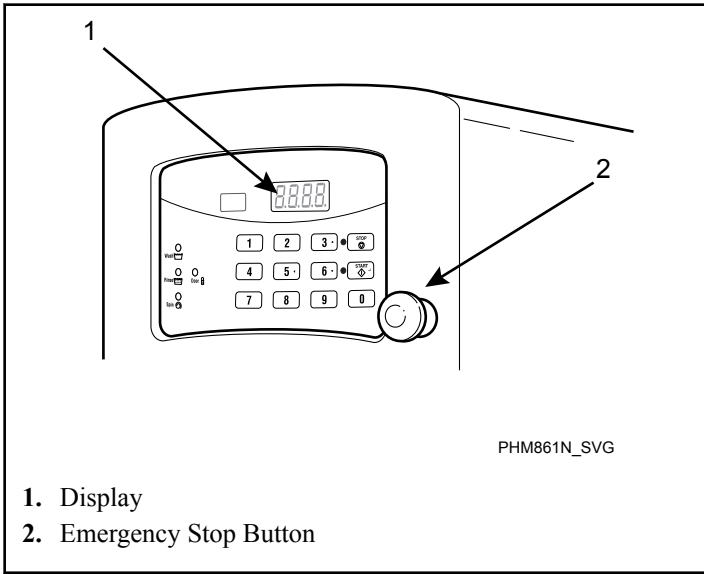

Figure 39

2. Turn the door handle clockwise and swing the door left to open it. Refer to *Figure 40*.

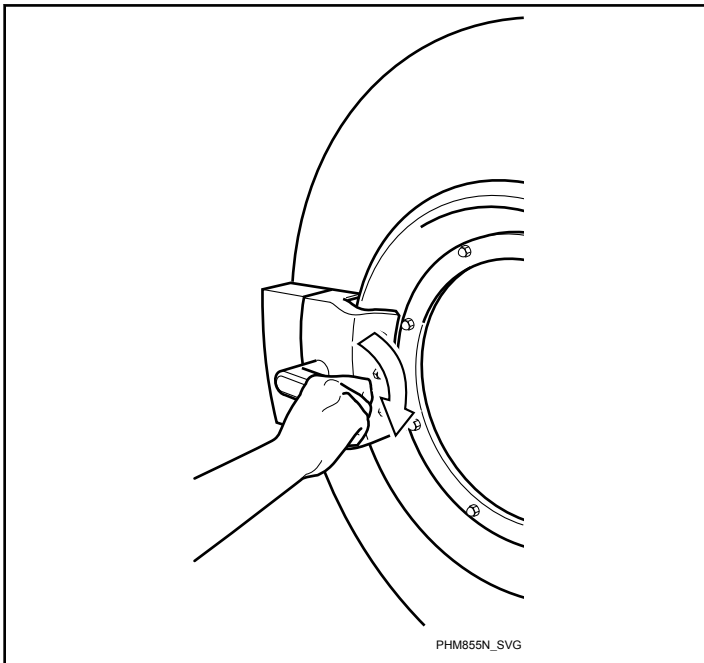

Figure 40

3. Load to capacity whenever possible. **DO NOT OVERLOAD**  
Underloading can cause out-of-balance conditions that can shorten machine life.

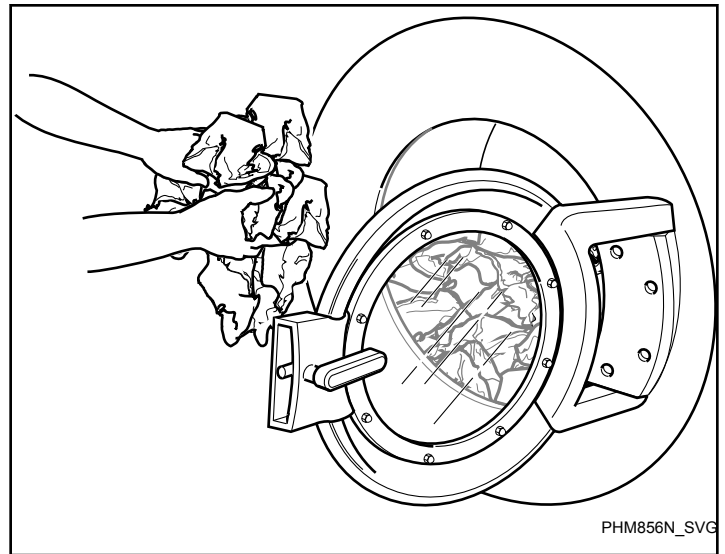

Figure 41

	<h2>CAUTION</h2>
<p><b>Be careful around the open door, particularly when loading from a level below the door. Impact with door edges can cause personal injury.</b></p>	
<p>SW025</p>	

**NOTE:** When washing items which may disintegrate or fragment, such as mop heads or sponges, use laundry nets to prevent drain blockage.

**IMPORTANT:** To prevent out-of-balance conditions, premature wear or damage to machine when using laundry nets, use several small nets in a load.

4. Close the door by rotating the handle counterclockwise. Refer to *Figure 42*.

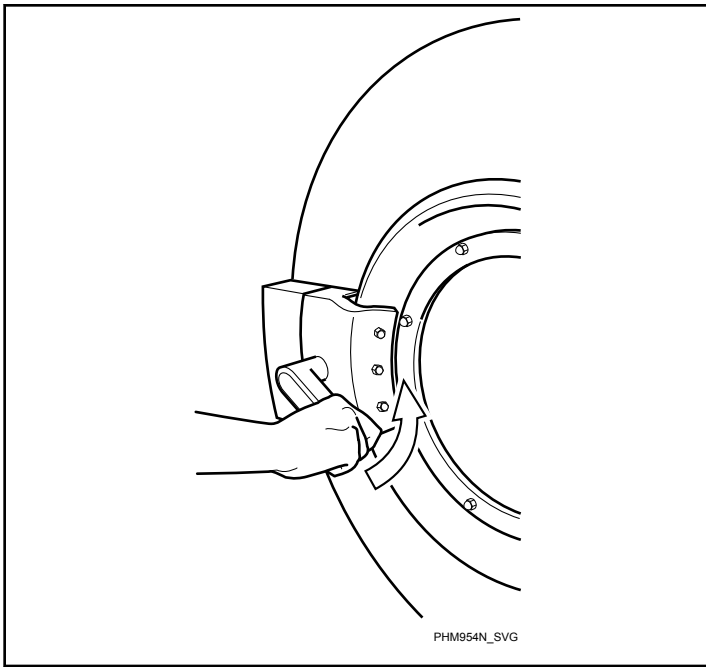

Figure 42

5. If equipped with an optional supply dispenser, add dry supplies to the compartment cups prior to the start of each cycle.

Liquid supplies can be injected directly into supply dispenser by an external chemical supply system.

**NOTE: Supply dispenser compartment cups must not be removed when an external chemical injection supply system is attached to the machine.**

6. Press the numeric keypads to select the desired wash cycle. Refer to *Table 35*.

Cycle Number	Cycle Name
1	Permanent Press Light Soil
2	Light Soil
3	Permanent Press Medium Soil
4	Medium Soil
5	Permanent Press Heavy Soil
6	Heavy Soil
7	Rags
8	Reclaim
9	Delicates
10	90°C
11	60°C
12	40°C
13	90°C Permanent Press
14	60°C Permanent Press
15	40°C Permanent Press
16	70°C Permanent Press
17	50°C Gentle
18	30°C Gentle
19	Custom #1
20	Custom #2
21	Custom #3
22	Custom #4
23	Custom #5
24	Custom #6
25	Custom #7
26	Custom #8
27	Custom #9
28	Custom #10
29	Custom #11
30	Custom #12

Table 35

	<b>CAUTION</b>
<p><b>Water cannot be extracted from rubber backed items. To avoid damage to machine from out of balance conditions, do not use a spin (extract) step when washing rubber backed items. Warranty will be voided.</b></p>	
W880	

7. Press the START keypad to start the selected cycle. As the cycle proceeds, the display will show and count down the remaining cycle time. To begin the cycle at any step other than the first step, press the START keypad to advance through the cycle to the desired starting point. Refer to the **Programming Manual** for information to disable Rapid Advance. If the door is open, the display will indicate that the door needs to be closed and locked.
8. Close the door to start a cycle. The cycle will continue until its completion. Then the display will show the door is ready to be unlocked and opened.

**NOTE: Since the machine MUST drain and balance before it can extract, the control will only Rapid Advance to a drain step that occurs before an extract or spray rinse extract step.**

9. Emergency stop button (refer to *Figure 39*) should be depressed to terminate machine operation when any unsafe condition is present during machine operation.
  - a. Press red emergency stop button to stop all action.
  - b. To restart machine, pull red emergency stop button out and press START keypad.

**NOTE: Activation of the emergency stop button stops all machine control circuit functions, but DOES NOT remove all electrical power from machine.**

**Shakeout Routine**

	<b>WARNING</b>
<p><b>NEVER insert hands or objects into basket until it has completely stopped. Doing so could result in serious injury.</b></p>	
SW012	

A shakeout agitation step is programmed at the end of every cycle and will help prevent tangling of the load.

The shakeout time is set at the factory to agitate for 32 seconds.

# Start Up

## Basket Rotation

After installation is complete, run the machine through a test cycle and check that basket rotation is counter clockwise in the extract step.

1. If rotation is not counter clockwise, disconnect power to machine.
2. Have a qualified electrician reverse any two motor leads at the motor.

## Safety Stability Switch Operation

After machine is properly installed, the safety Stability Switch operation must be verified.

1. Locate the green-colored switch on the rear, left-side of the frame.
2. Place a large magnet above the normally-closed ball switch to verify switch operation.

**IMPORTANT: Machines are manufactured with a normally-closed ball switch and should not require any adjustment. To avoid nuisance tripping, machine must be level with a summed value of 3/8 inch (9.5 mm) front to back and right to left to the earth. If switch is tripped, check if machine is level and then for poor grouting and broken anchor bolts. DO NOT BYPASS SAFETY SWITCH. Contact a qualified service technician for further assistance.**

# Maintenance

## Maintenance

Routine maintenance maximizes operating efficiency and minimizes downtime. The maintenance procedures described below will prolong the life of the machine and help prevent accidents.

	<b>WARNING</b>
<p><b>Sharp edges can cause personal injury. Wear safety glasses and gloves, use proper tools and provide lighting when handling sheet metal parts.</b></p>	
W366R1	

	<b>CAUTION</b>
<p><b>Replace all panels that are removed to perform service and maintenance procedures. Do not operate the machine with missing guards or with broken or missing parts. Do not bypass any safety devices.</b></p>	
SW019	

Follow local codes for proper advise on laundering infected garments.

On UniLine Control models, maintenance checklists are also displayed on the control. Press  to enter Service Schedule Menu. Refer to *Figure 43*.

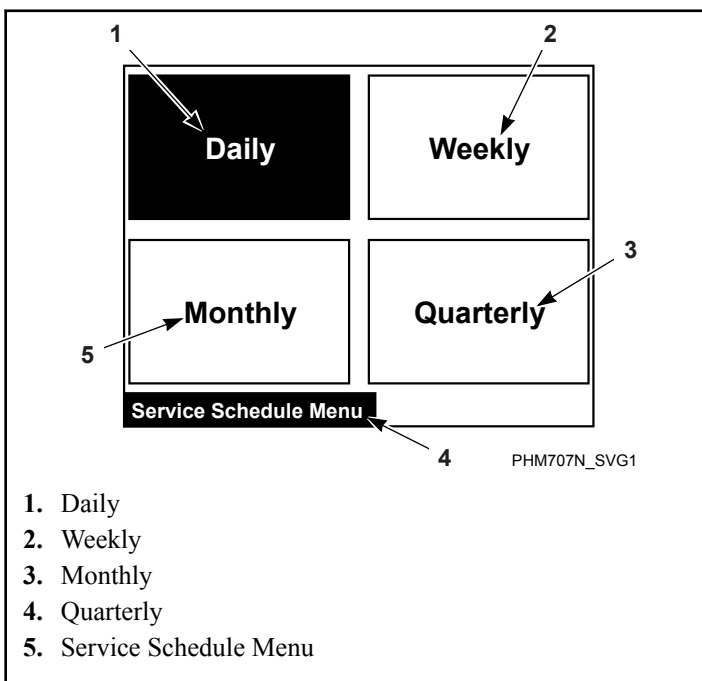



Figure 43

Press  from Cycle Menu to enter Service Menu. The Service Menu provides a user with a time based service reminder list. The list is broken up into “DAILY”, “WEEKLY”, “MONTHLY” and “QUARTERLY”.

The following maintenance procedures must be performed regularly at the required intervals.

## Daily

**IMPORTANT: Replace all panels that are removed to perform maintenance procedures. Do not operate the machine with missing guards or with broken or missing parts. Do not bypass any safety devices.**

	<b>WARNING</b>
<p><b>Do not spray the machine with water. Short circuiting and serious damage may result.</b></p>	
unique_49_Connect_42_note-1437506691659	

**IMPORTANT: Door lock should be checked daily to ensure proper operation. Also check that all safety and instruction stickers are on the machine. Any missing or illegible safety instructions stickers should be replaced immediately.**

## Beginning of Day

- Check door interlock before starting operation:
  - Attempt to start the machine with the door open. The machine should not start.
  - Close the door without locking it and start the machine. The machine should not start.
  - Attempt to open the door while the cycle is in progress. The door should not open.

If the door lock and interlock are not functioning properly, disconnect power and call a service technician.

- Check the machine for leaks.
  - Start an unloaded cycle to fill the machine.
  - Verify that door and door gasket do not leak.
  - Verify that the drain valve is operating and that the drain system is free from obstruction. If water does not leak out during the first wash segment, the drain valve is closed and functioning properly.
- Inspect water inlet valve hose connections on the back of the machine for leaks.
- Inspect steam hose connections for leaks (if applicable).
- On machines equipped with an automatic Chemical Supply System, check all the hoses and hose connections for leaks or

visible signs of deterioration. Replace immediately if either are present. Chemical leaks can cause damage to the machine's components.

	<b>WARNING</b>
<p><b>To reduce the risk of electrical shock, serious injury or death, disconnect the electrical power to washer-extractor before examining the wiring.</b></p>	
W636	

6. Verify that insulation is intact on all external wires and that all connections are secure. If bare wire is evident, call a service technician.
7. If the machine is equipped with a premium Wet Clean module, inspect the water recirculation pipe connections to make sure that they are tight and do not leak.
8. Ensure all panels and guards are properly installed.

### End of Day

1. Clean the inverter drive and control module fan filters:
  - a. Remove the external plastic cover which contains the filter.
  - b. Remove the foam filter from the cover.
  - c. Wash the filter with warm water and allow to air dry. Filter can be vacuumed clean.

**IMPORTANT: The control module and drive box cover and fan filter must be in place for the fan to properly cool the AC inverter drive and front end control. Failure to observe this warning will void the warranty and could lead to expensive AC inverter drive repair or front end control replacement.**

**NOTE: Inverter drive box filter(s) should be replaced every five years.**

2. Clean the AC drive and control module fan filters (if applicable).

**IMPORTANT: The control module cover and fan filter must be in place for the fan to properly cool the AC inverter drive. Failure to observe this warning will void the warranty and could lead to expensive AC inverter drive repair.**

3. Inspect and clean the basket, door glass and door gasket of residual detergent and all foreign matter.
4. Clean automatic supply dispenser and lid (if applicable) inside and out with mild detergent. Flush the dispenser with clean water.
5. Clean the machine's top, front and side panels with all-purpose cleaner. Rinse with clean water and dry.

**NOTE: Unload the machine promptly after each completed cycle to prevent moisture buildup. Leave loading door and dispenser lid open at the end of each completed cycle to allow moisture to evaporate.**

**IMPORTANT: Use only isopropyl alcohol to clean graphic overlays. Never use ammonia-based, vinegar-based or acetone-based cleaners on graphic overlays.**

6. If the machine is equipped with a premium Wet Clean module, clean the water recirculation filter, which is located inside of the canister.
7. Leave the loading door open at the end of each day to allow moisture to evaporate.
8. Shut off water supply.

### Monthly

**NOTE: Disconnect power to the machine at its source before performing the monthly maintenance procedures.**

1. Verify points of contact at terminals and quick disconnects are firm throughout the machine by gently tugging the wires. Re-seat any loose contacts.
2. Each month OR after every 200 hours of operation, lubricate bearings (locate the bearing lubrication decal at the rear of the left side of the machine, as viewed from the front). Visually inspect grease line for air pockets; purge to remove.

The grease must have the following characteristics:

- NLGI Grade 2
- Lithium-based
- Water-insoluble
- Anti-rusting
- Anti-oxidizing
- Mechanically stable

The grease must have adequate base oil viscosity with one of the following ratings:

- ISO VG 150 ( 709–871 SUS at 100°F [135–165 cSt at 40°C])
- ISO VG 220 ( 1047–1283 SUS at 100°F [198–242 cSt at 40°C])
- An SAE 40 rating is also acceptable as long as the cSt or SUS values are within the specified ranges.

Pump the grease gun slowly, permitting only 2 strokes.

3. Clean inlet hose filter screens:
  - a. Turn water off and allow valve and water line to cool, if necessary.
  - b. Unscrew inlet hose and remove filter screen.
 

**NOTE: All filter screens should be replaced every five years.**
  - c. Clean with soapy water and reinstall. Replace if worn or damaged.
4. Clean customer-supplied steam filter (if applicable). Refer to *Figure 44*.
  - a. Turn off steam supply and allow time for the valve to cool.
  - b. Unscrew cap.

- c. Remove element and clean.
- d. Replace element and cap.

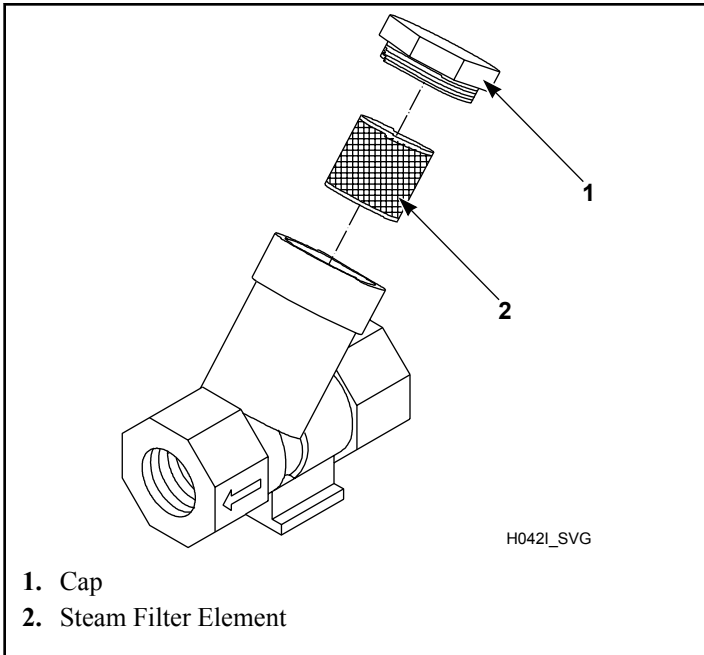

Figure 44

5. Clean interior of machine, by wiping with a water-soaked sponge or cloth. Use compressed air to clear debris between the shell and the basket by directing it through the perforations of the basket.

## Yearly

**NOTE: Disconnect power to the machine at its source before performing the quarterly maintenance procedures.**

1. Remove the front panel(s) and rear access panels and inspect all hose, drain, and overflow connections/clamps for leaks. Inspect all hoses for visible signs of deterioration. Replace as necessary.
2. Inspect and vacuum clean the inverter heat sink (if applicable).
3. Use a vacuum to clean lint from motor.
4. Remove chemical supply components and check all flush hoses and connections for residual chemicals, leaks or visible signs of deterioration. Clean or replace as necessary.
5. If applicable, check the supply dispenser hoses and hose connections for leaks or visible signs of deterioration. Replace immediately if either are present.

**NOTE: Hoses and other natural rubber parts deteriorate after extended use. Hoses may develop cracks, blisters or material wear from the temperature and constant high pressure they are subjected to.**

**NOTE: All hoses should be replaced every five years.**

6. Use compressed air to ensure that all electrical components including coin acceptors (if applicable) are free of moisture and dust.
7. Tighten door hinges and fasteners, if necessary.
8. Tighten motor mounting bolt locknuts and bearing bolt locknuts, if necessary.
9. Check the tightness of the motor spring and motor pulley hardware. Also check that the eyebolt is tightened properly.
10. Verify that the drain motor shield is in place and secure, if so equipped.
11. Check the bearing mounting bolts to make sure they are torqued to  $357 \pm 35$  ft-lbs.
12. Use the following procedures to determine if belt(s) require replacement or adjustment. Call a qualified service technician in either case.
  - a. Check V-belt for uneven wear and frayed edges. Belts must not be twisted and must be fully seated on pulleys.
  - b. After disconnecting power to the machine and removing all panels necessary for access to the drive belt, use one of the following methods to verify that the V-belt is properly tensioned.

**NOTE: Basket pulley must be rotated three (3) full turns before assessing belt tension after every adjustment.**

- **Frequency Gauge.** Tighten eyebolt top nut until the correct frequency (refer to *Table 36*) is obtained mid-span. Torque jam nut to spring bracket to  $20.6 \pm 2$  ft.-lbs. Refer to *Figure 45*.

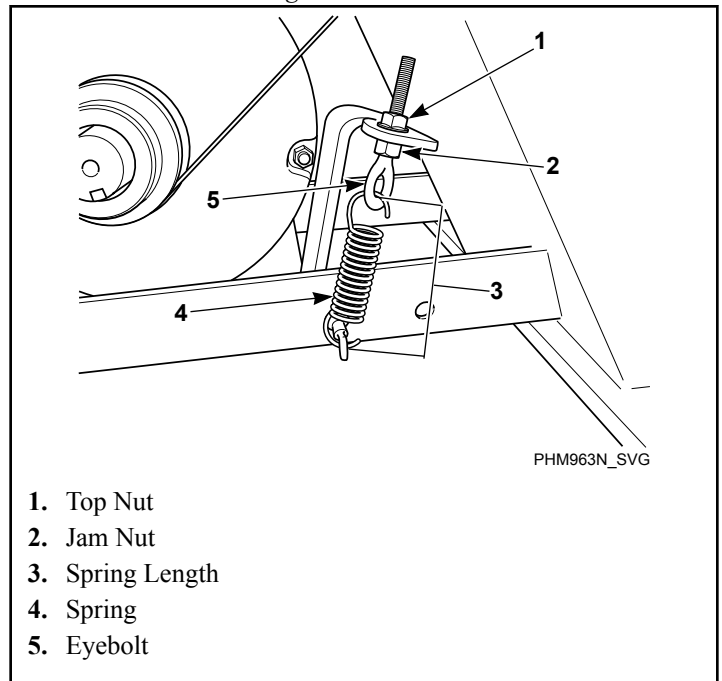

Figure 45

- **Tension Gauge.** Tighten eyebolt top nut until the proper belt gauge (refer to *Table 36*) is obtained mid-span.

Torque jam nut to spring bracket to  $20.6 \pm 2$  ft.-lbs. Refer to *Figure 45* .

- **Spring Length.** Tighten eyebolt top nut until the spring measures 3 15/16 inches [103 mm] (45-65 pound models) or (85-160 pound models) between the hooks. Torque jam nut to spring bracket to  $20.6 \pm 2$  ft.-lbs. Refer to *Figure 45* .
- **Maintain Tension During Belt Removal.** If proper tension is achieved, tape the jam nut in place and loosen eyebolt top nut to release the belt. Replace belt and retighten eyebolt top nut back to jam nut position. Refer to *Figure 45* .

**IMPORTANT: All torque joints must remain dry (non-lubricated).**

- c. Verify that V-belts are properly aligned by checking pulley alignment. On 45-105 pound models the motor pulley should align with end of motor shaft to align belts. On 130-165 pound models, slide the motor pulley along the motor shaft and secure once belt alignment on the sheave is attained.
  1. Install belt on basket sheave.
  2. Install belt on motor pulley.
  3. Insert belt in appropriate motor pulley grooves so belt rides on the center of the basket sheave. Belt must be centered on basket pulley within .09 inches [2.3 mm].

Mod-els	Frequen-cy (Hz)	Belt Ten-sion (lbs.)	Tension Gauge (N)
45-65	$58 \pm 2$	$108 \pm 7$	$481 \pm 32$
85-105	$62 \pm 2$	$183 \pm 11$	$816 \pm 52$
130-160	$52 \pm 2$	$214 \pm 16$	$954 \pm 72$

Table 36

13. Place a large magnet over the normally-closed ball switch to verify the stability switch operation.
14. Run a factory test. Reference Programming Manual for procedure details and components tested.
15. Remove the back panel and check overflow hose and drain hose for leaks or visible signs of deterioration. Replace immediately if either are present.
16. Check all painted surfaces for bare metal.
  - If bare metal is showing, paint with primer or solvent-based paint.
  - If rust appears, remove it with sandpaper or by chemical means. Then paint with primer or solvent-based paint.
17. Tighten anchor bolts as specified in the *Machine Mounting and Grouting* section, if necessary. Inspect grout for cracking.
18. From the rear of the machine, locate the air trap hose through the hole in the frame. Remove and check for debris.

**IMPORTANT: All torque joints must remain dry (non-lubricated).**

## Care of Stainless Steel

- Remove dirt and grease with detergent and water. Thoroughly rinse and dry after washing.
- Avoid contact with dissimilar metals to prevent galvanic corrosion when salty or acidic solutions are present.
- Do not allow salty or acidic solutions to evaporate and dry on stainless steel. Wipe clean of any residues.
- Rub in the direction of the polish lines or “grain” of the stainless steel to avoid scratch marks when using abrasive cleaners. Use stainless steel wool or soft, non-metal bristle brushes. Do not use ordinary steel wool or steel brushes.
- If the stainless steel appears to be rusting, the source of the rust may be an iron or steel part not made of stainless steel, such as a nail or screw.
- Remove discoloration or heat tint from overheating by scouring with a powder or by employing special chemical solutions.
- Do not leave sterilizing solutions on stainless steel equipment for prolonged periods of time.
- When an external chemical supply is used, ensure no siphoning of chemicals occurs when the machine is not in use. Highly concentrated chemicals can cause severe damage to stainless steel and other components within the machine. Damage of this kind is not covered by the manufacturer’s warranty. Locate the pump and tubing below the machine’s injection point to prevent siphoning of chemicals into the machine.

# Disposal of Unit

## Disposal of Unit

This appliance is marked according to the European directive 2002/96/EC on Waste Electrical and Electronic Equipment (WEEE).

This symbol on the product or on its packaging indicates that this product shall not be treated as household waste. Refer to *Figure 46*. Instead it shall be handed over to the applicable collection point for the recycling of electrical and electronic equipment. Ensuring this product is disposed of correctly will help prevent potential negative consequences for the environment and human health which could otherwise be caused by inappropriate waste handling of this product. The recycling of materials will help to conserve natural resources. For more detailed information about recycling of this product, please contact the local city office, household waste disposal service, or the source from which the product was purchased.

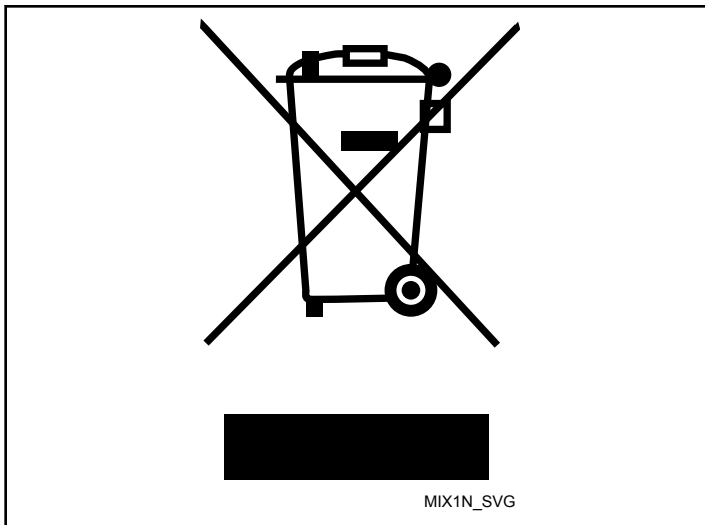

Figure 46

# China Restriction of hazardous substances (RoHS)

The Table of Hazardous Substances/Elements and their Content

As required by China's Management Methods for Restricted Use of Hazardous Substances in Electrical and Electronic Products

Hazardous substances						
Part Name	Lead (Pb)	Mercury (Hg)	Cadmium (Cd)	Hexavalent Chromium (CR[VI])	Polybrominated biphenyls (PBB)	Polybrominated diphenyl ethers (PBDE)
PCBs	X	O	O	O	O	O
Electromechanical Parts	O	O	O	O	O	O
Cables and Wires	O	O	O	O	O	O
Metal Parts	O	O	O	O	O	O
Plastic Parts	O	O	O	O	O	O
Batteries	O	O	O	O	O	O
Hoses and Tubing	O	O	O	O	O	O
Timing Belts	O	O	O	O	O	O
Insulation	O	O	O	O	O	O
Glass	O	O	O	O	O	O
Display	O	O	O	O	O	O

This table is prepared in accordance with the provisions of SJ/T-11364.

O: Indicates that the content of said hazardous substance in all of the homogenous materials in the component is within the limits required by GB/T 26572.

X: Indicates that the content of said hazardous substance exceeds the limits required by GB/T 26572 in at least one homogenous material in the component.

**All parts named in this table with an "X" are in compliance with the European Union's RoHS Legislation.**

**NOTE: The referenced Environmental Protection Use Period Marking was determined according to normal operating use conditions of the product such as temperature and humidity.**



This product under normal use, durable years of environmental protection is 15 years.