

# TOSHIBA

FILE NO. 140-200603GR  
(MFR'S VERSION A)

## SERVICE MANUAL

### COLOR TELEVISION/ DVD VIDEO PLAYER

# *MD20F52*

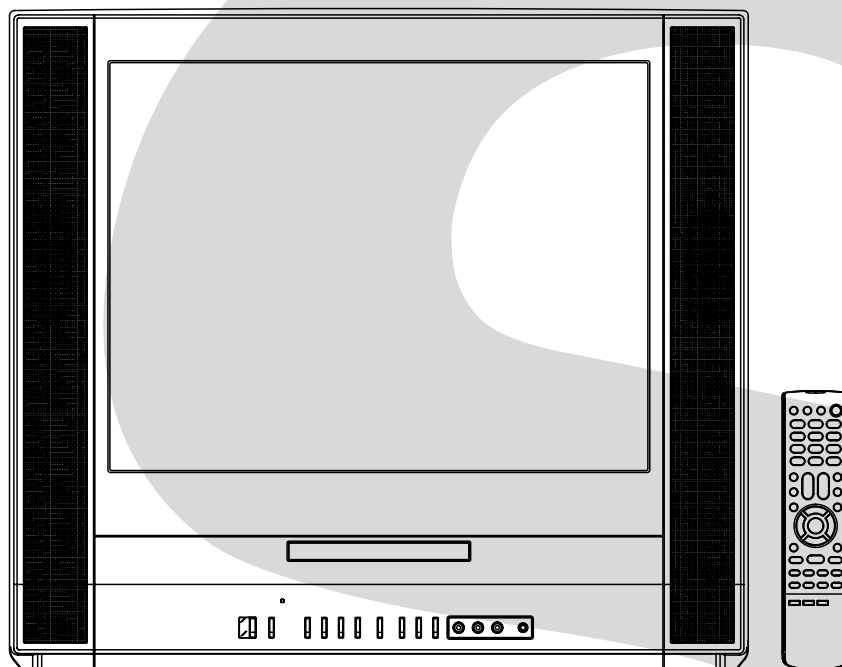

The above model is classified as a green product (\*1), as indicated by the underlined serial number. This Service Manual describes replacement parts for the green product. When repairing this green product, use the part(s) described in this manual and lead-free solder (\*2).

For (\*1) and (\*2), see the next page.

(\*1)

## GREEN PRODUCT PROCUREMENT

The EC is actively promoting the WEEE & RoHS Directives that define standards for recycling and reuse of Waste Electrical and Electronic Equipment and for the Restriction of the use of certain Hazardous Substances. From July 1, 2006, the RoHS Directive will prohibit any marketing of new products containing the restricted substances.

Increasing attention is given to issues related to the global environmental. Toshiba Corporation recognizes environmental protection as a key management tasks, and is doing its utmost to enhance and improve the quality and scope of its environmental activities. In line with this, Toshiba proactively promotes Green Procurement, and seeks to purchase and use products, parts and materials that have low environmental impacts.

Green procurement of parts is not only confined to manufacture. The same green parts used in manufacture must also be used as replacement parts.

(\*2)

## LEAD-FREE SOLDER

This product is manufactured using lead-free solder as a part of a movement within the consumer products industry at large to be environmentally responsible. Lead-free solder must be used in the servicing and repair of this product.

### **WARNING**

**This product is manufactured using lead free solder.**

### **DO NOT USE LEAD BASED SOLDER TO REPAIR THIS PRODUCT !**

The melting temperature of lead-free solder is higher than that of leaded solder by 86°F to 104°F (30°C to 40°C). Use of a soldering iron designed for lead-based solders to repair product made with lead-free solder may result in damage to the component and or PCB being soldered. Great care should be made to ensure high-quality soldering when servicing this product — especially when soldering large components, through-hole pins, and on PCBs — as the level of heat required to melt lead-free solder is high.

## CAUTION

THIS DIGITAL VIDEO PLAYER EMPLOYS A LASER SYSTEM.

TO ENSURE PROPER USE OF THIS PRODUCT, PLEASE READ THIS SERVICE MANUAL CAREFULLY AND RETAIN FOR FUTURE REFERENCE. SHOULD THE UNIT REQUIRE MAINTENANCE, CONTACT AN AUTHORIZED SERVICE LOCATION-SEE SERVICE PROCEDURE.

USE OF CONTROLS, ADJUSTMENTS OR THE PERFORMANCE OF PROCEDURES OTHER THAN THOSE SPECIFIED HEREIN MAY RESULT IN HAZARDOUS RADIATION EXPOSURE.

TO PREVENT DIRECT EXPOSURE TO LASER BEAM, DO NOT TRY TO OPEN THE ENCLOSURE. VISIBLE LASER RADIATION MAY BE PRESENT WHEN THE ENCLOSURE IS OPENED. DO NOT STARE INTO BEAM.

### Location of the required Marking

The rating sheet and the safety caution are on the rear of the unit.

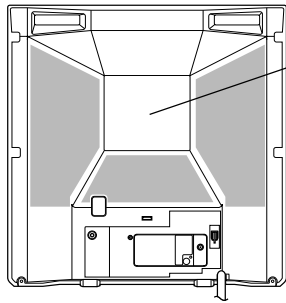

CERTIFICATION: COMPLIES WITH FDA RADIATION PERFORMANCE STANDARDS, 21 CFR SUBCHAPTER J.

## PREPARATION OF SERVICING

The laser diode used for a pickup head may be destroyed with external static electricity. Moreover, even if it is operating normally after repair, when static electricity discharge is received at the time of repair, the life of the product may be shortened. Please perform the following measure against static electricity, be careful of destruction of a laser diode at the time of repair.

- Place the unit on a workstation equipped to protect against static electricity, such as conductive mat.
- Soldering iron with ground wire or ceramic type is used.
- A worker needs to use a ground conductive wrist strap for body.

## SERVICING NOTICES ON CHECKING

### 1. KEEP THE NOTICES

As for the places which need special attentions, they are indicated with the labels or seals on the cabinet, chassis and parts. Make sure to keep the indications and notices in the operation manual.

### 2. AVOID AN ELECTRIC SHOCK

There is a high voltage part inside. Avoid an electric shock while the electric current is flowing.

### 3. USE THE DESIGNATED PARTS

The parts in this equipment have the specific characters of incombustibility and withstand voltage for safety. Therefore, the part which is replaced should be used the part which has the same character.

Especially as to the important parts for safety which is indicated in the circuit diagram or the table of parts as a  mark, the designated parts must be used.

### 4. PUT PARTS AND WIRES IN THE ORIGINAL POSITION AFTER ASSEMBLING OR WIRING

There are parts which use the insulation material such as a tube or tape for safety, or which are assembled in the condition that these do not contact with the printed board. The inside wiring is designed not to get closer to the pyrogenic parts and high voltage parts. Therefore, put these parts in the original positions.

### 5. TAKE CARE TO DEAL WITH THE CATHODE-RAY TUBE

In the condition that an explosion-proof cathode-ray tube is set in this equipment, safety is secured against implosion. However, when removing it or serving from backward, it is dangerous to give a shock. Take enough care to deal with it.

### 6. AVOID AN X-RAY

Safety is secured against an X-ray by considering about the cathode-ray tube and the high voltage peripheral circuit, etc.

Therefore, when repairing the high voltage peripheral circuit, use the designated parts and make sure not modify the circuit.

Repairing except indicates causes rising of high voltage, and it emits an X-ray from the cathode-ray tube.

### 7. PERFORM A SAFETY CHECK AFTER SERVICING

Confirm that the screws, parts and wiring which were removed in order to service are put in the original positions, or whether there are the portions which are deteriorated around the serviced places serviced or not. Check the insulation between the antenna terminal or external metal and the AC cord plug blades. And be sure the safety of that.

#### (INSULATION CHECK PROCEDURE)

1. Unplug the plug from the AC outlet.
2. Remove the antenna terminal on TV and turn on the TV.
3. Insulation resistance between the cord plug terminals and the eternal exposure metal **[Note 2]** should be more than 1M ohm by using the 500V insulation resistance meter **[Note 1]**.
4. If the insulation resistance is less than 1M ohm, the inspection repair should be required.

#### **[Note 1]**

If you have not the 500V insulation resistance meter, use a Tester.

#### **[Note 2]**

External exposure metal: Antenna terminal

## HOW TO ORDER PARTS

Please include the following informations when you order parts. (Particularly the VERSION LETTER.)

### 1. MODEL NUMBER and VERSION LETTER

The MODEL NUMBER can be found on the back of each product and the VERSION LETTER can be found at the end of the SERIAL NUMBER.

### 2. PART NO. and DESCRIPTION

You can find it in your SERVICE MANUAL.

# IMPORTANT SAFEGUARDS

---

## 1. READ INSTRUCTIONS

All the safety and operating instructions should be read before the unit is operated.

## 2. RETAIN INSTRUCTIONS

The safety and operating instructions should be retained for future reference.

## 3. HEED WARNINGS

All warnings on the unit and in the operating instructions should be adhered to.

## 4. FOLLOW INSTRUCTIONS

All operating and use instructions should be followed.

## 5. CLEANING

Unplug this unit from the wall outlet before cleaning. Do not use liquid cleaners or aerosol cleaners. Use a damp cloth for cleaning.

## 6. ATTACHMENTS

Do not use attachments not recommended by the unit's manufacturer as they may cause hazards.

## 7. WATER AND MOISTURE

Do not use this unit near water. For example, near a bathtub, washbowl, kitchen sink, or laundry tub, in a wet basement, or near a swimming pool.

## 8. ACCESSORIES

Do not place this unit on an unstable cart, stand, tripod, bracket, or table. The unit may fall, causing serious injury, and serious damage to the unit. Use only with a cart, stand, tripod, bracket, or table recommended by the manufacturer.

- 8A. An appliance and cart combination should be moved with care. Quick stops, excessive force, and uneven surfaces may cause the appliance and cart combination to overturn.

## 9. VENTILATION

Slots and openings in the cabinet and in the back or bottom are provided for ventilation, to ensure reliable operation of the unit, and to protect it from overheating. These openings must not be blocked or covered. The openings should never be blocked by placing the unit on a bed, sofa, rug, or other similar surface. This unit should never be placed near or over a radiator or heat source. This unit should not be placed in a built-in installation such as a bookcase or rack unless proper ventilation is provided or the manufacturer's instructions have been adhered to.

## 10. POWER SOURCES

This unit should be operated only from the type of power source indicated on the rating plate. If you are not sure of the type of power supply to your home, consult your appliance dealer or local power company. For units intended to operate from battery power, or other sources, refer to the operating instructions.

## 11. GROUNDING OR POLARIZATION

This unit is equipped with a polarized alternating-current line plug (a plug having one blade wider than the other). This plug will fit into the power outlet only one way. This is a safety feature. If you are unable to insert the plug fully into the outlet, try reversing the plug. If the plug should still fail to fit, contact your electrician to replace your obsolete outlet. Do not defeat the safety purpose of the polarized plug. If your unit is equipped with a 3-wire grounding-type plug, a plug having a third (grounding) pin, this plug will only fit into a grounding-type power outlet. This too, is a safety feature. If you are unable to insert the plug into the outlet, contact your electrician to replace your obsolete outlet. Do not defeat the safety purpose of the grounding-type plug.

## 12. POWER-CORD PROTECTION

Power-supply cords should be routed so that they are not likely to be walked on or pinched by items placed upon or against them, paying particular attention to cords at plugs, convenience receptacles, and the point where they exit from the appliance.

## 13. LIGHTNING

To protect your unit from a lightning storm, or when it is left unattended and unused for long periods of time, unplug it from the wall outlet and disconnect the antenna or cable system. This will prevent damage to the unit due to lightning and power line surges.

## 14. POWER LINES

An outside antenna system should not be located in the vicinity of overhead power lines or other electric light or power circuits, or where it can fall into such power lines or circuits. When installing an outside antenna system, extreme care should be taken to keep from touching such power lines or circuits, as contact with them might be fatal.

## 15. OVERLOADING

Do not overload wall outlets and extension cords, as this can result in a risk of fire or electric shock.

## 16. OBJECT AND LIQUID ENTRY

Do not push objects through any openings in this unit, as they may touch dangerous voltage points or short out parts that could result in fire or electric shock. Never spill or spray any type of liquid into the unit.

PORTABLE CART WARNING  
(symbol provided by RETAC)



S3126A

## 17. OUTDOOR ANTENNA GROUNDING

If an outside antenna or cable system is connected to the unit, be sure the antenna or cable system is grounded so as to provide some protection against voltage surges and built-up static charges. Section 810 of the National Electrical Code, ANSI/NFPA 70, provides information with respect to proper grounding of the mast and supporting structure, grounding of the lead-in wire to an antenna discharge unit, size of grounding conductors, location of antenna discharge unit, connection to grounding electrodes, and requirements for the grounding electrode.

## 18. SERVICING

Do not attempt to service this unit yourself as opening or removing covers may expose you to dangerous voltage or other hazards. Refer all servicing to qualified service personnel.

## 19. DAMAGE REQUIRING SERVICE

Unplug this unit from the wall outlet and refer servicing to qualified service personnel under the following conditions:

- a. When the power-supply cord or plug is damaged.
- b. If liquid has been spilled, or objects have fallen into the unit.
- c. If the unit has been exposed to rain or water.
- d. If the unit does not operate normally by following the operating instructions. Adjust only those controls that are covered by the operating instructions, as an improper adjustment of other controls may result in damage and will often require extensive work by a qualified technician to restore the unit to its normal operation.
- e. If the unit has been dropped or the cabinet has been damaged.
- f. When the unit exhibits a distinct change in performance, this indicates a need for service.

## 20. REPLACEMENT PARTS

When replacement parts are required, be sure the service technician uses replacement parts specified by the manufacturer or those that have the same characteristics as the original parts.

Unauthorized substitutions may result in fire, electric shock or other hazards.

## 21. SAFETY CHECK

Upon completion of any service or repairs to this unit, ask the service technician to perform safety checks to determine that the unit is in proper operating condition.

## 22. WALL OR CEILING MOUNTING

The product should be mounted to a wall or ceiling only as recommended by the manufacturer.

## 23. HEAT

The product should be situated away from heat sources such as radiators, heat registers, stoves, or other products (including amplifiers) that produce heat.

## 24. DISC TRAY

Keep your fingers well clear of the disc tray as it is closing. It may cause serious personal injury.

## 25. CONNECTING

When you connect the product to other equipment, turn off the power and unplug all of the equipment from the wall outlet. Failure to do so may cause an electric shock and serious personal injury. Read the owner's manual of the other equipment carefully and follow the instructions when making any connections.

## 26. SOUND VOLUME

Reduce the volume to the minimum level before you turn on the product. Otherwise, sudden high volume sound may cause hearing or speaker damage.

## 27. SOUND DISTORTION

Do not allow the product output distorted sound for a longtime. It may cause speaker overheating and fire.

## 28. HEADPHONES

When you use the headphones, keep the volume at a moderate level. If you use the headphones continuously with high volume sound, it may cause hearing damage.

## 29. LASER BEAM

Do not look into the opening of the disc tray or ventilation opening of the product to see the source of the laser beam. It may cause sight damage.

## 30. DISC

Do not use a cracked, deformed, or repaired disc. These discs are easily broken and may cause serious personal injury and product malfunction.

## 31. NOTE TO CATV SYSTEM INSTALLER

This reminder is provided to call the CATV system installer's attention to Article 820-40 of the NEC that provides guidelines for proper grounding and, in particular, specifies that the cable ground shall be connected to the grounding system of the building, as close to the point of cable entry as practical.

# IMPORTANT SAFEGUARDS

(CONTINUED)

EXAMPLE OF ANTENNA GROUNDING AS PER THE NATIONAL ELECTRICAL CODE

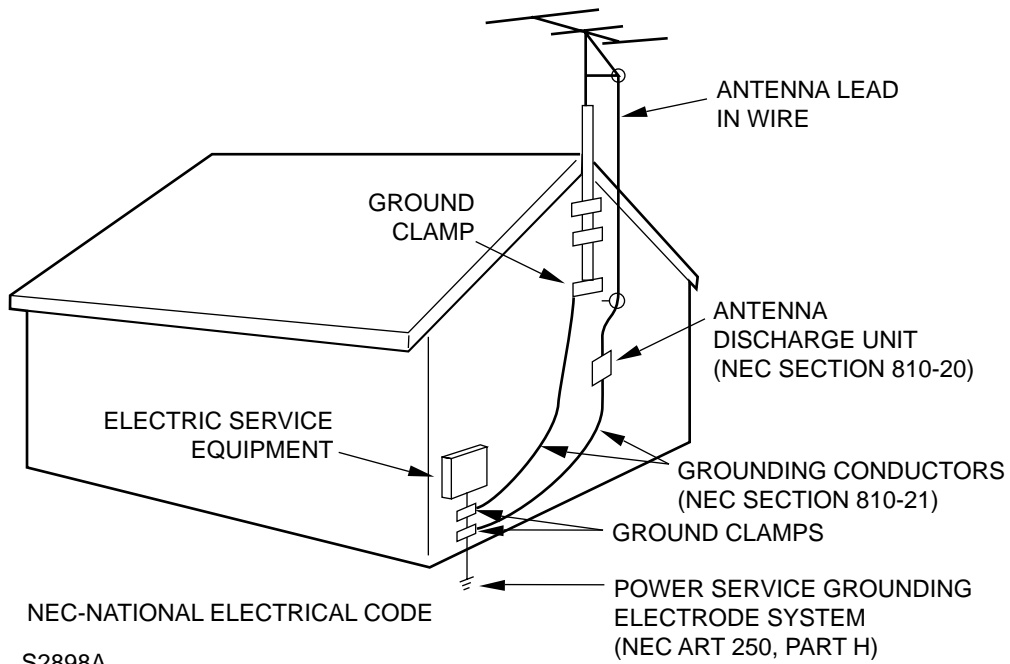

## WHEN REPLACING DVD DECK

### [ When removing the DVD Deck ]

Before removing Pick Up PCB and DVD PCB connector, the short circuit the position shown in **Fig. 1** using a soldering iron. If you remove the DVD Deck with no soldering, the Laser may be damaged.

### [ When installing the DVD Deck ]

Remove all the soldering on the short circuit position after the connection of Pick Up PCB and DVD PCB connector.

### NOTE

- Before your operation, please read "PREPARATION OF SERVICING".
- Use the Lead Free solder.
- Manual soldering conditions
  - Soldering temperature:  $350 \pm 5^{\circ}\text{C}$
  - Soldering time: Within 2 seconds
  - Soldering combination: Sn-3.0Ag-0.5Cu
- When Soldering/Removing of solder, use the draw in equipment over the Pick Up Unit to keep the Flux smoke away from it.

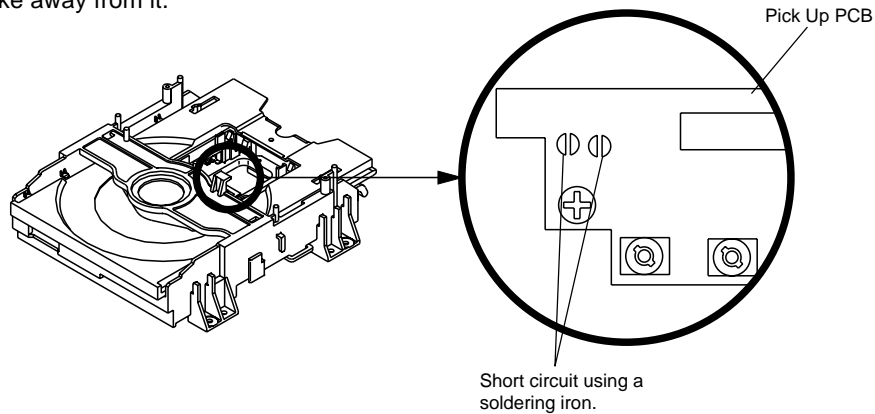

Fig. 1

## DISC REMOVAL METHOD AT NO POWER SUPPLY

1. Remove the Back Cabinet and AV PCB/DVD Block. (Refer to item 1 of the **DISASSEMBLY INSTRUCTIONS.**)
2. Rotate the Main Gear in the direction of the arrow by hand. (Refer to **Fig. 1**)
3. Manually open the Tray.

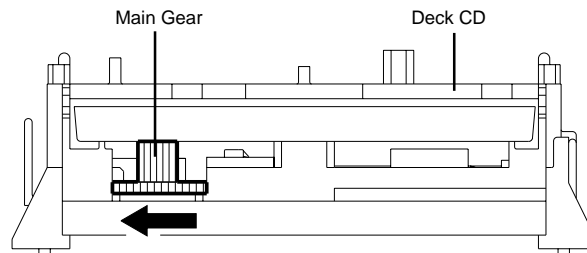

Fig. 1

## PARENTAL CONTROL - RATING LEVEL 4 DIGIT PASSWORD CANCELLATION

If the stored 4 digit password in the Rating Level menu needs to be cancelled, please follow the steps below.

1. Turn Unit ON.
2. Set the DVD Mode.
3. Confirm that the 'No Disc' will be appeared on the screen.
4. Press and hold the '7' key on the remote control unit.
5. Simultaneously press and hold the 'STOP' key on the front panel.
6. Hold both keys for more than 3 seconds.
7. The On Screen Display message 'PASSWORD CLEAR' will appear.
8. The 4 digit password has now been cleared

## TRAY LOCK

Tray cannot be opened by setting the Tray Lock, please follow the steps below.

1. Turn Unit ON.
2. Set the DVD to the Stop Mode.
3. Press and hold the 'STOP' key on the front panel.
4. Simultaneously press and hold the '9' key on the remote control unit.
5. Hold both keys for more than 3 seconds.
6. The On Screen Display message '  ' will appear.
7. The Tray Lock has now been set up.

**NOTE:** No indications on the screen when the Tray Lock is setting.

To unlock the Tray Lock, please follow the steps below.

1. Turn Unit ON.
2. Set the DVD to the Stop Mode.
3. Press and hold the 'STOP' key on the front panel.
4. Simultaneously press and hold the '9' key on the remote control unit.
5. Hold both keys for more than 3 seconds.
6. The On Screen Display message '  ' will appear.
7. The Tray Lock has now been cleared.

**NOTE:** No indications on the screen when the Tray Lock is setting.

It is likely to be going to be changed to the following steps without a previous notice in the future.

If the above is not effective measures, please follow the steps below.

Tray cannot be opened by setting the Tray Lock, please follow the steps below.

1. Turn Unit ON.
2. Set the DVD to the Stop Mode.
3. Press it in order of 'SETUP', 'SUBTITLE', '3', 'AUDIO SELECT' and '0' key of a remote control unit.
4. The On Screen Display message '  ' will appear.
5. The Tray Lock has now been set up.

**NOTE:** No indications on the screen when the Tray Lock is setting.

To unlock the Tray Lock, please follow the steps below.

1. Turn Unit ON.
2. Set the DVD to the Stop Mode.
3. Press it in order of 'SETUP', 'SUBTITLE', '3', 'AUDIO SELECT' and '0' key of a remote control unit.
4. The On Screen Display message '  ' will appear.
5. The Tray Lock has now been cleared.

**NOTE:** No indications on the screen when the Tray Lock is setting.

# TABLE OF CONTENTS

<b>GREEN PRODUCT PROCUREMENT</b> .....	A1-1
<b>LEAD-FREE SOLDER</b> .....	A1-1
<b>CAUTION</b> .....	A1-2
<b>SERVICING NOTICES ON CHECKING</b> .....	A1-3
<b>HOW TO ORDER PARTS</b> .....	A1-3
<b>IMPORTANT SAFEGUARDS</b> .....	A1-4~A1-6
<b>WHEN REPLACING DVD DECK</b> .....	A1-7
<b>DISC REMOVAL METHOD AT NO POWER SUPPLY</b> .....	A1-7
<b>PARENTAL CONTROL-RATING LEVEL</b> .....	A1-8
<b>TRAY LOCK</b> .....	A1-8
<b>TABLE OF CONTENTS</b> .....	A2-1
<b>GENERAL SPECIFICATIONS</b> .....	A3-1~A3-6
<b>DISASSEMBLY INSTRUCTIONS</b>	
1. REMOVAL OF MECHANICAL PARTS AND P. C. BOARDS .....	B1-1, B1-2
2. REMOVAL OF DVD DECK PARTS .....	B2-1~B2-4
3. REMOVAL OF ANODE CAP .....	B3-1
4. REMOVAL AND INSTALLATION OF FLAT PACKAGE IC .....	B4-1, B4-2
<b>SERVICE MODE LIST</b> .....	C-1
<b>WHEN REPLACING EEPROM (MEMORY) IC</b> .....	C-1, C-2
<b>ELECTRICAL ADJUSTMENTS</b> .....	D-1~D-6
<b>BLOCK DIAGRAMS</b>	
DVD .....	E-1, E-2
TV .....	E-3, E-4
POWER .....	E-5, E-6
<b>PRINTED CIRCUIT BOARDS</b>	
DVD .....	F-1, F-2
AV/CRT .....	F-3~F-6
LOADING MOTOR/SW .....	F-7, F-8
<b>SCHEMATIC DIAGRAMS</b>	
MPEG/MICON/DSP .....	G-1, G-2
MEMORY .....	G-3, G-4
MOTOR DRIVE .....	G-5, G-6
AUDIO/VIDEO .....	G-7, G-8
REGULATOR .....	G-9, G-10
MICON/TUNER .....	G-11, G-12
SOUND AMP .....	G-13, G-14
IN/OUT .....	G-15, G-16
DEFLECTION .....	G-17, G-18
CRT .....	G-19, G-20
POWER .....	G-21, G-22
CHROMA .....	G-23, G-24
COMB/FILTER .....	G-25, G-26
STEREO .....	G-27, G-28
LOADING MOTOR/SW .....	G-29, G-30
<b>INTERCONNECTION DIAGRAM</b> .....	G-31, G-32
<b>WAVEFORMS</b> .....	H-1~H-3
<b>MECHANICAL EXPLODED VIEWS</b> .....	I1-1~I1-3
<b>DVD DECK EXPLODED VIEW</b> .....	I2-1
<b>MECHANICAL REPLACEMENT PARTS LIST</b> .....	J1-1
<b>DVD DECK REPLACEMENT PARTS LIST</b> .....	J2-1
<b>ELECTRICAL REPLACEMENT PARTS LIST</b> .....	J3-1~J3-5

## GENERAL SPECIFICATIONS

<b>G-1</b>	<b>TV System</b>	CRT	CRT Size / Visual Size	20 inch / 508.0 mmV	
			CRT Type	Flat	
			Magnetic Field BV/BH	+0.45G / 0.18G	
		Color System		NTSC	
	Speaker		Position	2 Speaker	
			Size	Front	
			Impedance	1.8 x 3.9 inch	
	Sound Output	Max		8 ohm	
		10%(Typical)		2.5W + 2.5W	
<b>G-2</b>	<b>DVD System</b>	Color System		NTSC	
		Disc		DVD, CD-DA, CD-R/RW, Video CD DVD-R/RW (Video Format Only)	
		Disc Diameter		120 mm , 80 mm	
		Drive		DM3S	
		Search speed	Fwd		4 step
				Actual	2-120 times(DVD, VIDEO CD) 4-40 times (CD)
			Rev		4 step
				Actual	2-120 times(DVD, VIDEO CD) 4-40 times (CD)
			Slow speed		Fwd 1/7 - 1/2 times
				Actual	--
		Actual	Rev --		
		Actual	--		
<b>G-3</b>	<b>Tuning System</b>	Broadcasting System		US System M	
		Tuner and Receive CH	System	1Tuner	
			Destination	US(w/CABLE)	
			CH Coverage	2-69, 4A, A-5-A-1, A-I, J-W, W+1-W+84	
		Intermediate Frequency	Picture(FP)	45.75MHz	
			Sound(FS)	41.25MHz	
			FP-FS	4.50MHz	
		Preset CH		No	
Stereo/Dual TV Sound		US-Stereo			
Tuner Sound Muting		Yes			
<b>G-4</b>	<b>Signal</b>	Video Signal	Input Level	1 V p-p/75 ohm	
			Output Level	--	
			S/N Ratio (Weighted)	--	
			Horizontal Resolution at DVD Mode	--	
				--	
		RGB Signal	Output Level	--	
		Audio Signal	Input Level	-8.0dBm/50k ohm	
			Output Level	--	
			Digital Output Level	0.5 V p-p/75 ohm	
			S/N Ratio at DVD (Weighted)	--	
			Harmonic Distortion	--	
			Frequency Response :	at DVD	--
				at Video CD	--
				at SVCD	--
			at CD	--	

## GENERAL SPECIFICATIONS

<b>G-5</b>	<b>Power</b>	Power Source	AC DC	120V, 60Hz --
		Power Consumption	at AC at DC	115W at 120V 60Hz -- 3W at 120V 60Hz -- kWh/Year
		Protector	Stand by (at AC) Per Year Power Fuse Safety Circuit IC Protector(Micro Fuse) Dew Sensor	Yes Yes No No
<b>G-6</b>	<b>Regulation</b>		Safety Radiation X-Radiation Laser	UL FCC DHHS DHHS
<b>G-7</b>	<b>Temperature</b>		Operation Storage	+5oC ~ +40oC -20oC ~ +60oC
<b>G-8</b>	<b>Operating Humidity</b>			Less than 80% RH
<b>G-9</b>	<b>On Screen Display</b>	Menu(TV)		Yes
		Menu Type		Icon
		TV Setup		Yes
		Picture		Yes
		Audio		Yes
		Picture Preference		Yes
		Channel Setup		Yes
		TV/CABLE		Yes
		Auto CH Memory		Yes
		Add/ Delete		Yes
		V-chip Setup		Yes
		Language		Yes
		Sleep Timer		Yes
		CH / AV(LINE) / DVD		Yes
		Stereo/Audio Output		Yes
		Bilingual		No
		SAP		Yes
		Control Level	Volume	Yes
			Brightness / Contrast / Sharpness / Color	Yes
			Tint	Yes
	Bass/Treble/Balance	Yes		
	Caption / Text	Yes		
	Auto Search/Position	No		
	Game	Yes		
	Mute	Yes		

# GENERAL SPECIFICATIONS

<b>G-10</b>	<b>On Screen Display</b>	Menu (DVD)		Yes
		Menu Type		Icon
		Language		Yes
		Menu		Yes
		Subtitle		Yes
		Audio		Yes
		OSD Language(Set up Language)		No
		Video		Yes
		E.B.L. (Enhanced Black Level)		No
		TV Screen Size(4:3)		Yes
		OSD Display On/Off		Yes
		Picture Mode (Video/Film/Auto)		Yes
		JPEG Interval		Yes
		Screen Saver		No
		Audio		Yes
		DRC (Dynamic Range Control)		Yes
		Dialogue (On DRC[TV] / Off DRC[Std])		No
		Surround		No
		System		Yes
		Disc/Card Slot		No
		Password Lock/ Un Lock		Yes
		Parental		Yes
		Select Files		Yes
		HDMI (480p/1080i/720p)		No
		Output		No
		Open		Yes
		Close		Yes
		No disc		Yes
		Reading		Yes
		Play		Yes
		Still/Pause		Yes
		Stop		Yes
		Prohibit Mark		Yes
		PBC		Yes
		Step		Yes
		Skip(>> )		Yes
		Skip( <<)		Yes
		Random		Yes (CD, VIDEO CD, JPEG, MP3, WMA)
		Repeat		Yes
		Slow+		Yes
		Slow-		No
		Search+		Yes
		Search-		Yes
		Jump		Yes
		Resume		Yes
Title No.		Yes		
Chapter No.		Yes		
Track No.		Yes		
Time		Yes		
Sub Title No.		Yes		
Angle No.		Yes		
Vocal On/Off		No		
Audio No.		Yes		
Audio Stereo L/R		Yes (Video CD)		
Zoom		Yes		
Marker No.		Yes		
Program Play Back		Yes (CD, VIDEO CD, JPEG, MP3, WMA )		
Surround On/Off		No		
Screen Saver		No		
MP3, WMA, JPEG		Folder Name		
		File Name		
		File No		
		Time		
		Track No		
		Yes		
		Yes		
		Yes		
		Yes (MP3, WMA Only)		
		Yes		
<b>G-11</b>	<b>OSD Language</b>			English, French, Spanish
<b>G-12</b>	<b>Clock and Timer</b>	Sleep Timer	Max Time	120 Min
			Step	10 Min
		On/Off Timer	Program(On Timer / Off Timer)	No
		Wake Up Timer		No
	Timer Back-up (at Power Off Mode)	more than	--	Min      Sec

# GENERAL SPECIFICATIONS

G-13	Remote Control	Unit	RC-MG	
		Glow in Dark Remocon	No	
		Remocon Format	TOSHIBA	
		Format	TOSHIBA	
		Custom Code	40-BF H, 44-BB H, 45-BA H, 45-BC H	
		Power Source	Voltage(D.C) UM size x pcs	3V UM-4 x 2 pcs
		Total Keys		47 Key
		Keys	Power	Yes
			1	Yes
			2	Yes
			3	Yes
			4	Yes
			5	Yes
			6	Yes
			7	Yes
			8	Yes
			9	Yes
			0	Yes
			Play	Yes
			Stop	Yes
			Search+	Yes
			Search-	Yes
			Closed Caption/Skip+	Yes
			Quick View(CH RTN)/Skip-	Yes
			Slow+	Yes
			Slow-	No
			Pause/Still/Step	Yes
			DISPLAY	Yes
			TV/DVD	Yes
			Cancel	Yes
			Audio Select	Yes
			Angle	Yes
			Subtitle	Yes
			Top Menu	Yes
			Menu	Yes
			DVD Menu	Yes
			Return	Yes
			CH Up	Yes
			CH Down	Yes
			Vol Down	Yes
			Vol Up	Yes
			Up/ Set+	Yes
			Down/ Set-	Yes
			Left/Select-	Yes
			Right/Select+	Yes
			Enter	Yes
			Play Mode	Yes
			Input Select/Zoom	Yes
			Repeat A-B	Yes
			Mute	Yes
	Open/Close	Yes		
	Sleep	Yes		
	Marker	Yes		
	Jump	Yes		
	Game	Yes		

## GENERAL SPECIFICATIONS

<b>G-14</b>	<b>Features (TV)</b>	CABLE	Yes	
		Auto Shut Off	Yes	
		Auto Setup	Yes	
		Auto CH Memory	Yes	
		V-Chip	USA V-chip CANADA V-chip	Yes
		Auto Search		No
		SAP		No
		Game Position		Yes
		FM Transmitter		No
		Energy Star		No
		Closed Caption		Yes
		Comb Filter (2lines)		Yes
		Protect of FBT Leak Circuit		Yes
		Picture Preference		Yes
		Choke Coil		No
		Power On Memory		No
		<b>Features (DVD)</b>	Tray Lock	
	Video CD Playback			Yes
	SVCD Playback			No
	MP3 Playback			Yes
	WMA Playback			Yes
	JPEG Playback			Yes
	Digital Out		(Dolby Digital)	Yes
			(MPEG)	Yes
			(PCM)	Yes
			(DTS)	Yes
	Down Mix Out		(Dolby Digital)	Yes
		(DTS)	No	
3D Surround		No		
Screen Saver		No		
Closed Caption		Yes		
Audio DAC		192kHz / 24bit		
<b>G-15</b>	<b>Accessories</b>	Owner's Manual	Language w/Guarantee Card	English Yes
		Remote Control Unit		Yes
		Battery	UM size x pcs OEM Brand	Yes UM-4 x 2 pcs No
		Rod Antenna		No
			Poles	No
			Terminal	--
		Loop Antenna		No
			Terminal	--
		U/V Mixer		No
		300 ohm to 75 ohm Antenna Adapter		Yes
		Antenna Change Plug		No
		Guarantee Card		No
		Registration Card		Yes
		Warranty Card		No
		ESP Card		No
		Service Station List		No
		DC Car Cord (Center+)		No
		Columbia Offer Sheet		No
		Information Sheet (Return)		Yes
		Netflix Card		No

# GENERAL SPECIFICATIONS

<b>G-16</b>	<b>Interface</b>	Switch	Front	Power (Tact)	Yes
				Channel Up	Yes
				Channel Down	Yes
				Volume Up	Yes
				Volume Down	Yes
				Play	Yes
				Open/Close	Yes
				Skip+ /Search+	Yes
				Skip- /Search-	Yes
				Still/Pause	No
				Stop	Yes
				Main Power SW	No
				Indicator	Rear
		Power	Yes (Red)		
		Terminals	Front	Stand-by	No
				On Timer	No
				Video Input	RCA x 1
			Rear	Audio Input	RCA x 2(L/MONO, R)
				Other Terminal	Head Phone
				Video Input	RCA x 1
Audio Input	RCA x 2(L/MONO, R)				
Video Output	No				
Audio Output	No				
Digital Audio Output	Coaxial (DVD Only)				
Diversity	No				
DC Jack 12V(Center +)	No				
VHF/UHF Antenna Input	F Type				
<b>G-17</b>	<b>Set Size</b>		Approx. W x D x H (mm)	574x481.5x514.5	
<b>G-18</b>	<b>Weight</b>		Net (Approx.)	25.0kg (55.1lbs)	
			Gross (Approx.)	28.5kg (62.8lbs)	
<b>G-19</b>	<b>Carton</b>	Master Carton		No	
			Content	--- Sets	
			Material	--- / ---	
			Dimensions W x D x H(mm)	---	
		Gift Box	Description of Origin	---	
			Material	Double/Brown	
			W/Color Photo Label	No	
		Drop Test	Dimensions W x D x H(mm)	660 x 575 x 625	
			Description of Origin	Yes	
			Natural Dropping At Height (cm)	1 Corner / 2 Edges / 4 Surfaces 60 (ORION SPEC:31)	
	Container Stuffing (40' container)	216 Sets			
<b>G-20</b>	<b>Material</b>	Cabinet	Front	PS 94V0 DECABROM	
			Rear	PS 94V0 DECABROM	
			Jack Panel	-	
		PCB	Non-Halogen Demand	No	
			Eyelet Demand	Yes	
<b>G-21</b>	<b>Environment</b>		Environmental standard requirement	Green procurement of TOSHIBA	
			Pb-free	Phase3(Phase3A)	
			Measures of Whisker	Yes	

# DISASSEMBLY INSTRUCTIONS

## 1. REMOVAL OF MECHANICAL PARTS AND P.C. BOARDS

### 1-1: BACK CABINET (Refer to Fig. 1-1)

1. Remove the 7 screws ①.
2. Remove the screw ② which are used for holding the Back Cabinet.
3. Remove the AC cord from the AC cord hook ③.
4. Remove the Back Cabinet in the direction of arrow.

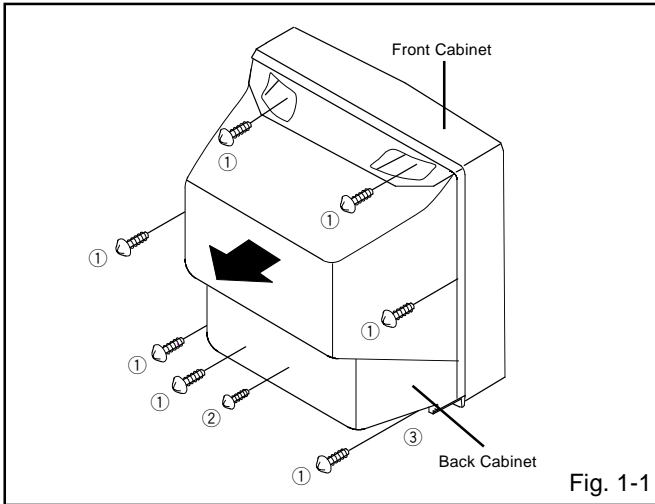

Fig. 1-1

### 1-2: CRT PCB (Refer to Fig. 1-2)

**CAUTION: BEFORE REMOVING THE ANODE CAP, DISCHARGE ELECTRICITY BECAUSE IT CONTAINS HIGH VOLTAGE. BEFORE ATTEMPTING TO REMOVE OR REPAIR ANY PCB, UNPLUG THE POWER CORD FROM THE AC SOURCE.**

1. Remove the Anode Cap.  
(Refer to REMOVAL OF ANODE CAP)
2. Disconnect the following connector:  
**(CP805).**
3. Remove the CRT PCB in the direction of arrow.

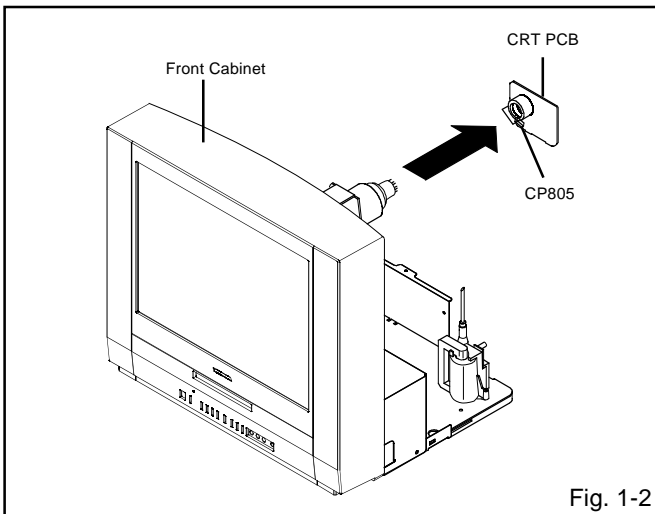

Fig. 1-2

### 1-3: AV PCB/DVD BLOCK (Refer to Fig. 1-3)

1. Remove the 2 screws ①.
2. Disconnect the following connectors:  
**(CP301, CP302, CP401 and CP3800).**
3. Remove the AV PCB/DVD Block in the direction of arrow.

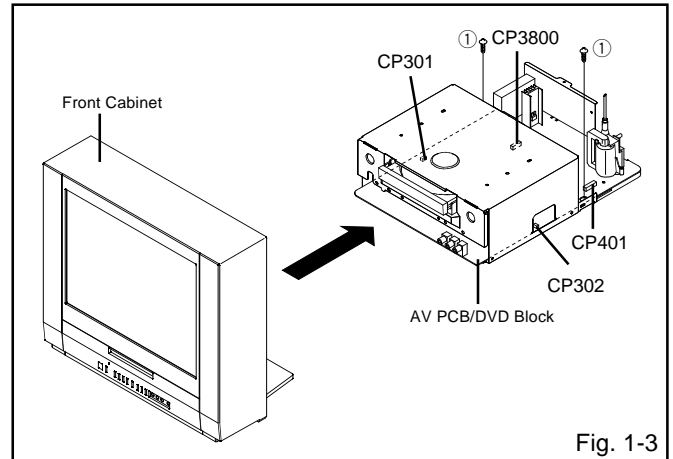

Fig. 1-3

### 1-4: DVD BLOCK (Refer to Fig. 1-4)

1. Remove the 11 screws ①.
2. Remove the Top Shield in the direction of arrow (A).
3. Disconnect the following connectors:  
**(CP8001 and CP8002).**
4. Remove the 4 screws ②.
5. Remove the DVD Block in the direction of arrow (B).
6. Remove the screw ③.
7. Remove the Jack Shield.
8. Remove the AV PCB in the direction of arrow (C).

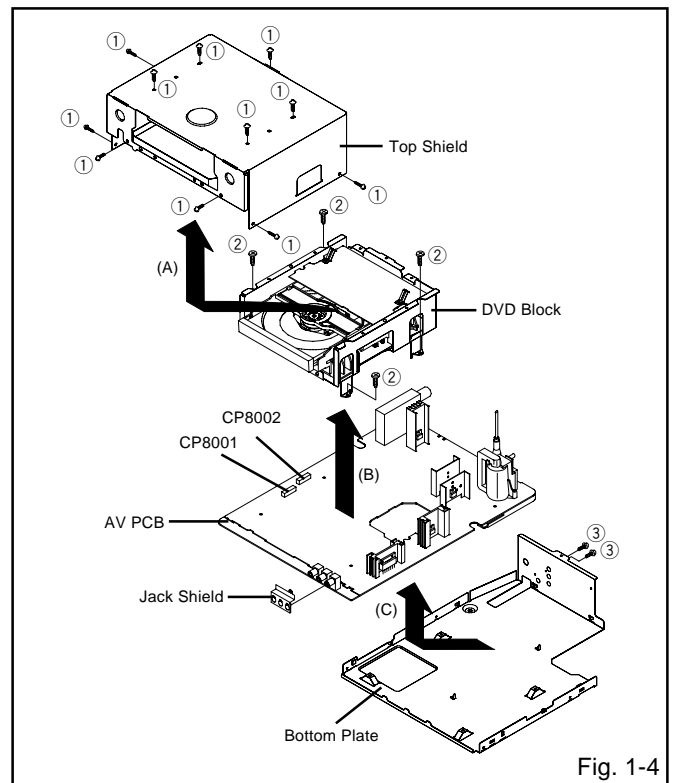

Fig. 1-4

## DISASSEMBLY INSTRUCTIONS

### 1-5: DVD PCB/DVD DECK (Refer to Fig. 1-5)

1. Short circuit the position shown in **Fig. 1-5** using a soldering iron. If you remove the DVD Deck with no soldering, the Laser may be damaged.
2. Unlock the 2 supports ①.
3. Remove the Front Tray Plate in the direction of arrow (A).
4. Remove the 4 screws ②.
5. Remove the DVD Deck in the direction of arrow (B).
6. Disconnect the following connectors:  
**(CP2301, CP2302 and CP2303).**
7. Remove the 2 screws ③.
8. Remove the DVD PCB in the direction of arrow (C).
9. Remove the 4 screws ④.
10. Remove the Deck Shield in the direction of arrow (D).

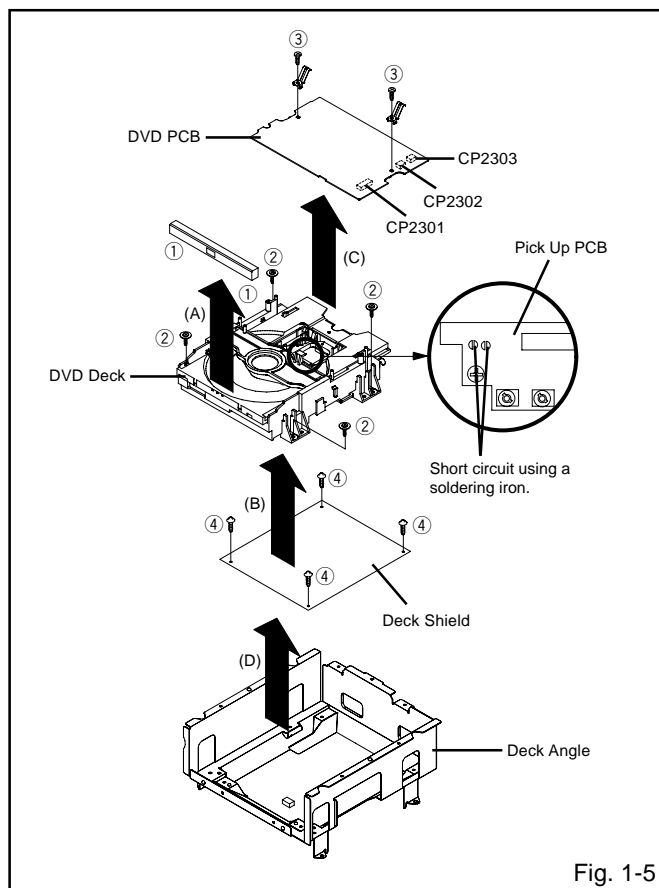

Fig. 1-5

### NOTE

1. Before your operation, please read "PREPARATION OF SERVICING".
2. Use the Lead Free solder.
3. Manual soldering conditions
  - Soldering temperature:  $350 \pm 5^{\circ}\text{C}$
  - Soldering time: Within 2 seconds
  - Soldering combination: Sn-3.0Ag-0.5Cu
4. When Soldering/Removing of solder, use the drawing equipment over the Pick Up Unit to keep the Flux smoke away from it.
5. When installing the DVD Deck, remove all the soldering on the short circuit position after the connection of Pick Up PCB and DVD PCB connector.

# DISASSEMBLY INSTRUCTIONS

## 2. REMOVAL OF DVD DECK PARTS

### NOTE

1. Do not disassemble the DVD DECK PARTS except listed parts here. Minute adjustments are needed if the disassemble is done. If the repair is needed except listed parts, replace the DVD MECHA ASS'Y.

### 2-1: TRAY (Refer to Fig. 2-1-A)

1. Set the Tray opened. (Refer to the DISC REMOVAL METHOD AT NO POWER SUPPLY)
2. Unlock the 2 supports ① and remove the Tray.

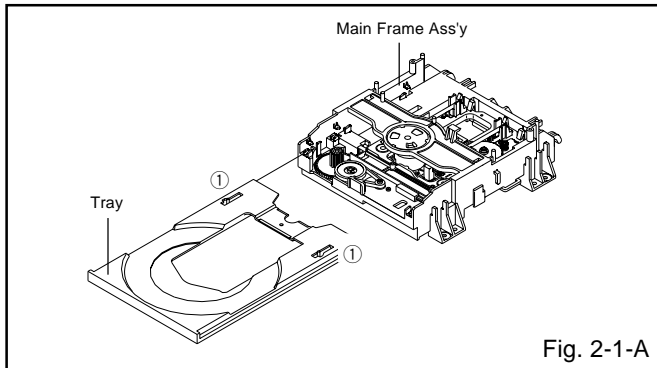

### NOTE

1. In case of the Tray installation, install them as the circled section of Fig. 2-1-B so that the each markers are met.

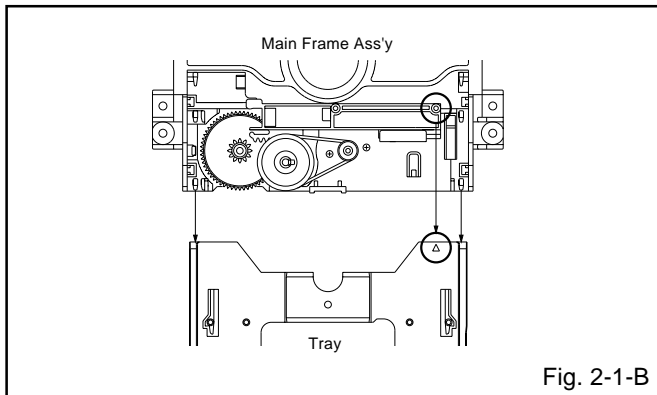

### 2-2: MAIN CHASSIS ASS'Y (Refer to Fig. 2-2-A)

1. Remove the screw ①.
2. Unlock the 2 supports ②.
3. Remove the Insulator (R) from the Main Frame Ass'y.
4. Remove the Main Chassis Ass'y.

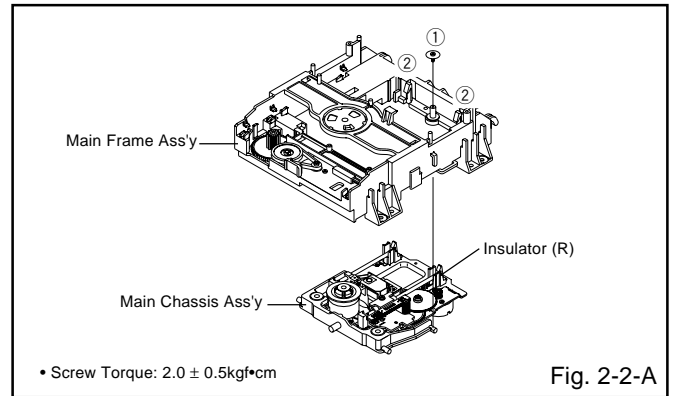

### NOTE

1. In case of the Main Chassis Ass'y, install it from (1) to (4) in order. (Refer to Fig. 2-2-B)
2. In case of the Main Chassis Ass'y installation, hook the wire on the Main Frame Ass'y as shown Fig. 2-2-C.

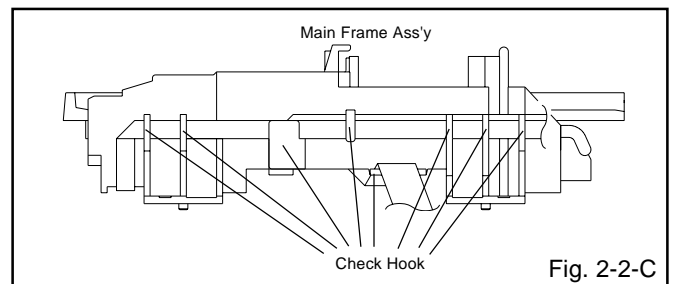
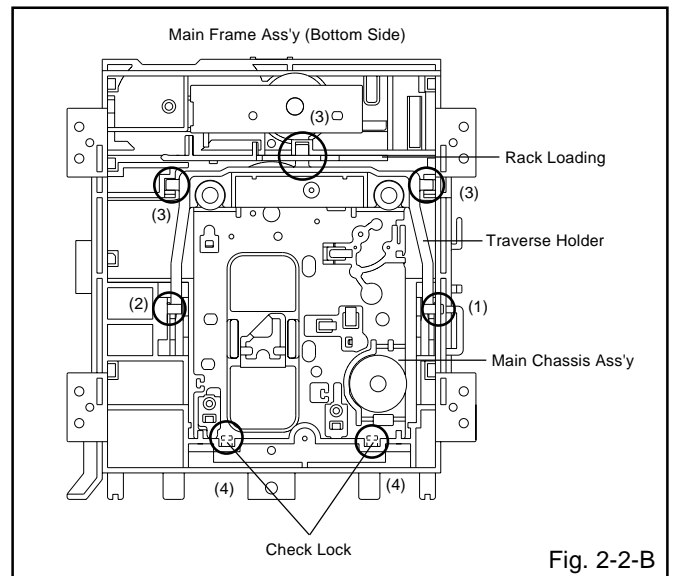

# DISASSEMBLY INSTRUCTIONS

## 2-3: LOADING MOTOR PCB ASS'Y/ LOADING BELT (Refer to Fig. 2-3-A)

1. Remove the Loading Belt.
2. Remove the screw ①.
3. Remove the 2 screws ②.
4. Remove the Loading Motor PCB Ass'y.
5. Remove the Pulley Gear.

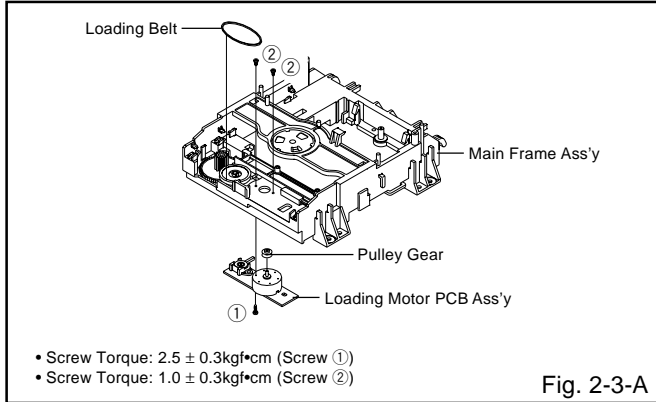

Fig. 2-3-A

### NOTE

1. In case of the Pulley Motor installation, check if the value of the Fig. 2-3-B is correct.
2. When installing the Loading Motor PCB Ass'y, install it correctly as Fig. 2-3-C.
3. In case of the Loading Motor PCB Ass'y installation, hook the wire on the Main Frame Ass'y as shown Fig. 2-3-C.

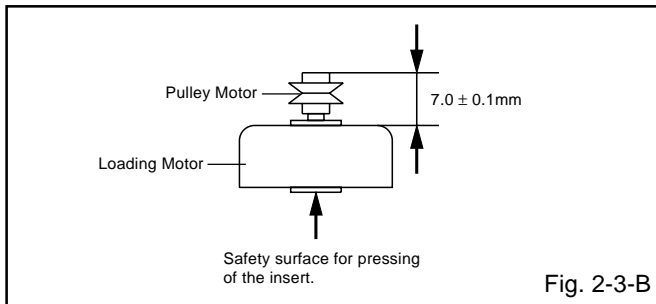

Fig. 2-3-B

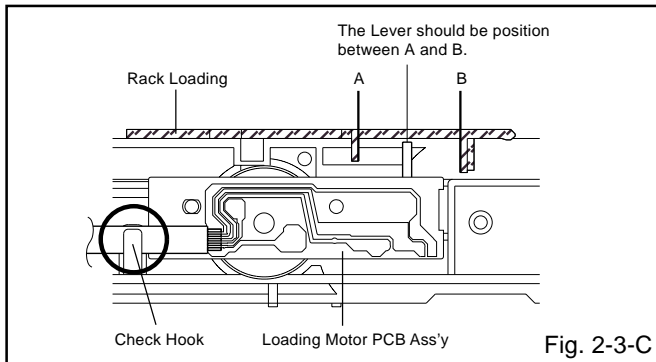

Fig. 2-3-C

## 2-4: RACK LOADING/MAIN GEAR/PULLEY GEAR (Refer to Fig. 2-4-A)

1. Press down the catcher ① and slide the Rack Loading.
2. Unlock the support ② and remove the Pulley Gear.
3. Remove the Main Gear.

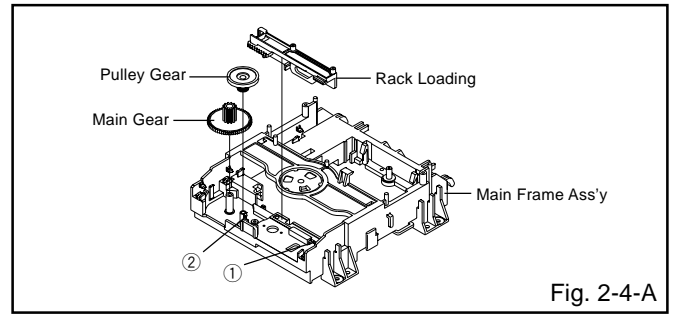

Fig. 2-4-A

### NOTE

1. In case of the Rack Loading installation, do not mesh it to the Main Gear as shown the Fig. 2-4-B.

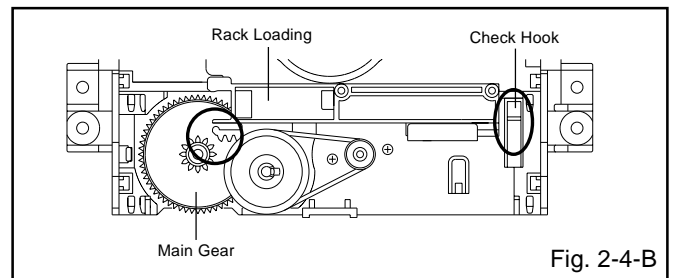

Fig. 2-4-B

## 2-5: CLAMPER ASS'Y (Refer to Fig. 2-5-A)

1. Press the Clamper and rotate the Clamper Plate clockwise, then unlock the 3 supports ①.
2. Remove the Clamper Plate, Clamper Magnet and Clamper.

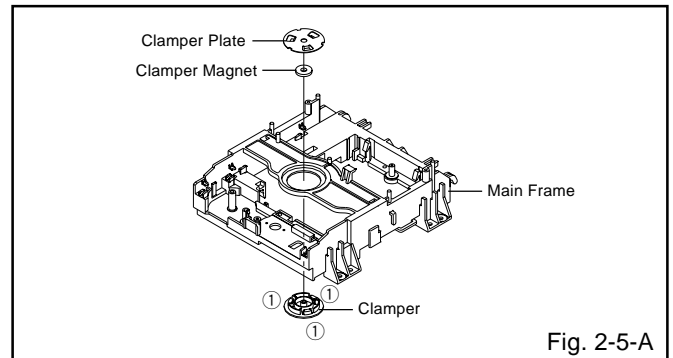

Fig. 2-5-A

### NOTE

1. In case of the Clamper Ass'y installation, install correctly as Fig. 2-5-B.

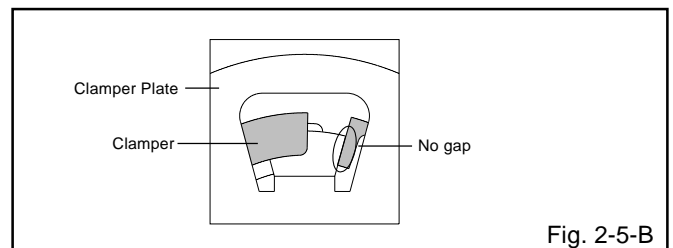

Fig. 2-5-B

# DISASSEMBLY INSTRUCTIONS

## 2-6: TRAVERSE HOLDER/INSULATOR (F)/INSULATOR (R) (Refer to Fig. 2-6-A)

1. Remove the Traverse Holder.
2. Remove the 2 Insulator (F).
3. Remove the Insulator (R).

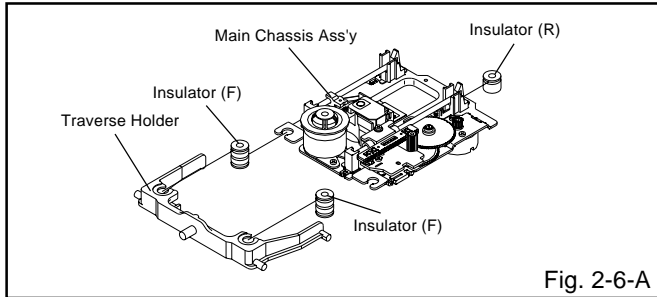

Fig. 2-6-A

### NOTE

1. In case of the Insulator (F) installation, install correctly as Fig. 2-6-B.
2. In case of the Insulator (R) installation, install correctly as Fig. 2-6-C.

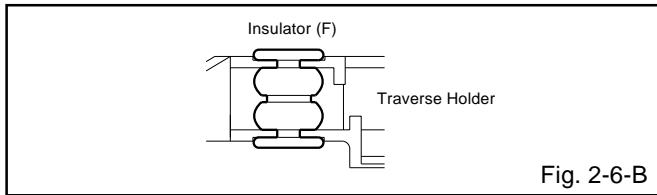

Fig. 2-6-B

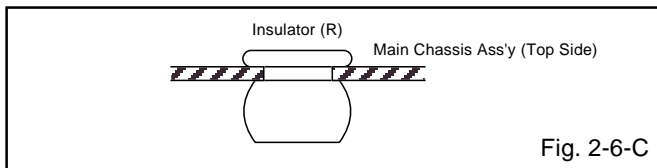

Fig. 2-6-C

## 2-7: RACK FEED ASS'Y/SWITCH PCB ASS'Y/FEED MOTOR (Refer to Fig. 2-7-A)

1. Remove the screw ①.
2. Remove the Rack Feed Ass'y.
3. Remove the screw ②.
4. Remove the Switch PCB Ass'y.
5. Remove the 2 screw ③.
6. Remove the Feed Motor.
7. Remove the Motor Gear.

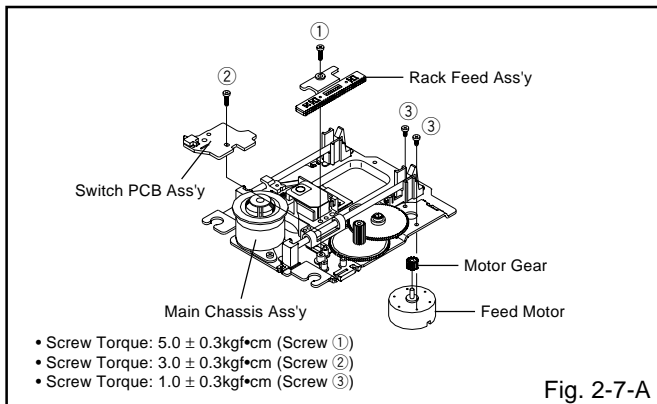

Fig. 2-7-A

### NOTE

1. When pushing the Rack Feed in the direction of the arrow, it should be restored to the original position by the spring force. (Refer to Fig. 2-7-B)
2. In case of the Motor Gear installation, check if the value of the Fig. 2-7-C is correct.
3. When installing the wire of the Switch PCB Ass'y, install it correctly as Fig. 2-7-D.
4. After the assembly of the Main Chassis Ass'y, hook the wire on the Main Chassis Ass'y as shown Fig. 2-7-E.

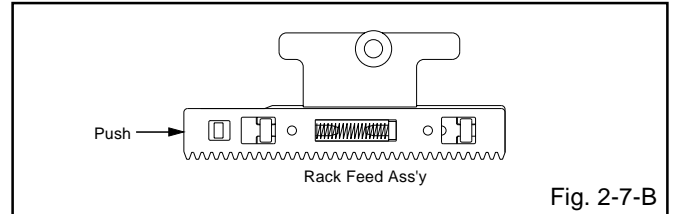

Fig. 2-7-B

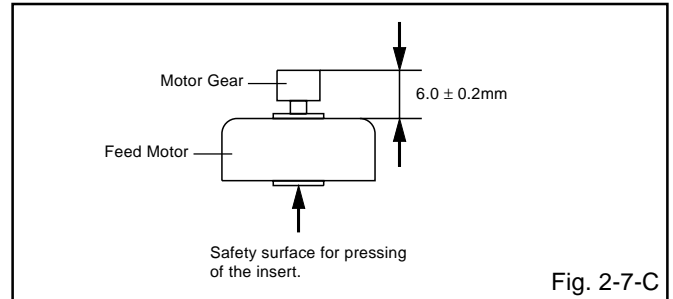

Fig. 2-7-C

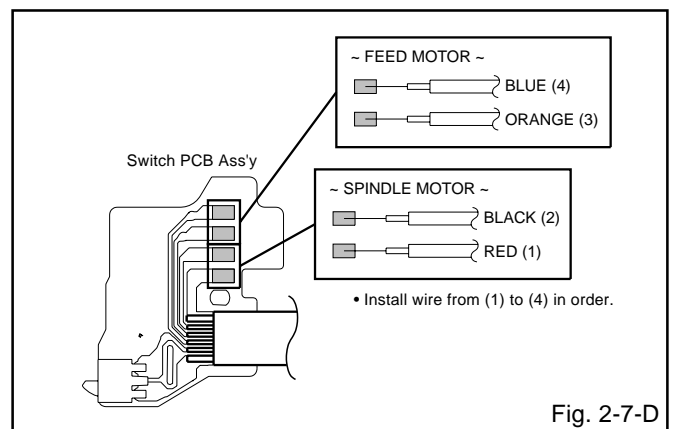

Fig. 2-7-D

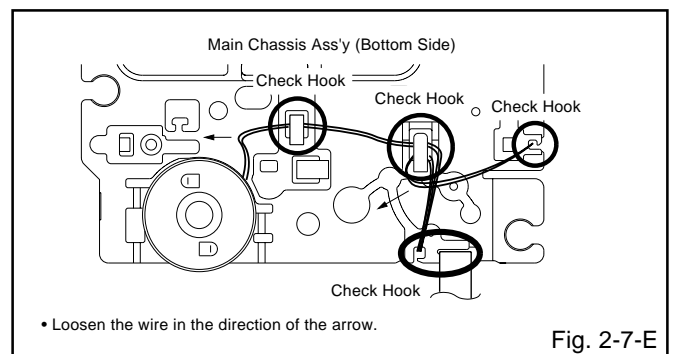

Fig. 2-7-E

# DISASSEMBLY INSTRUCTIONS

## 2-8: FFC WIRE HANDLING

1. When installing the FFC, fold it correctly and install it as shown from Fig. 2-8-A to Fig. 2-8-C.

### NOTE

1. Do not make the folding lines except the specified positions for the FFC.

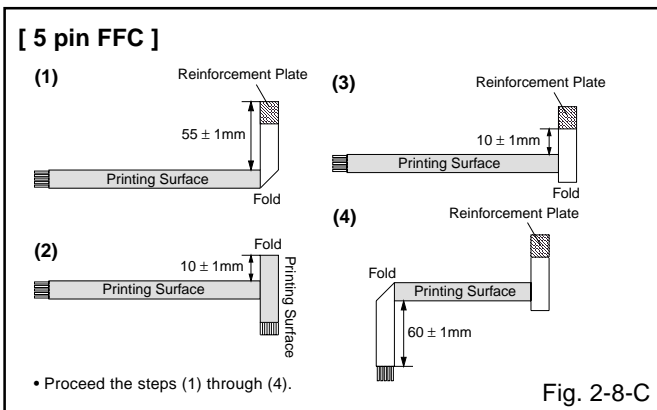
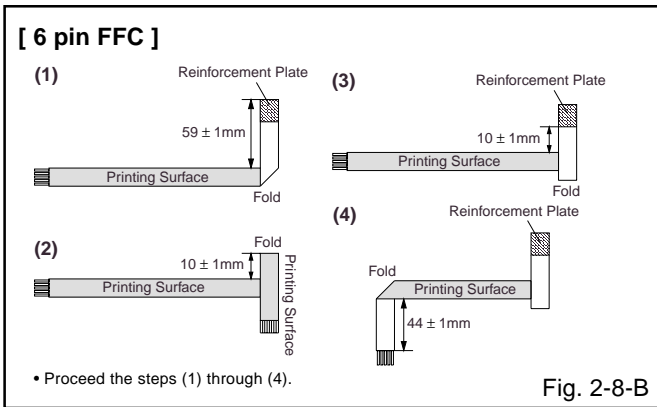
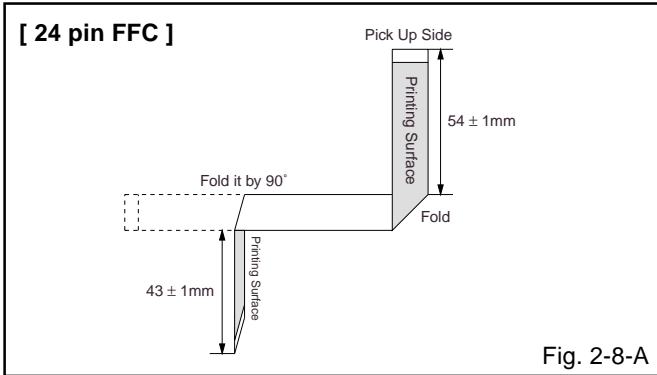

# DISASSEMBLY INSTRUCTIONS

## 3. REMOVAL OF ANODE CAP

Read the following **NOTED** items before starting work.

- \* After turning the power off there might still be a potential voltage that is very dangerous. When removing the Anode Cap, make sure to discharge the Anode Cap's potential voltage.
- \* Do not use pliers to loosen or tighten the Anode Cap terminal, this may cause the spring to be damaged.

### REMOVAL

1. Follow the steps as follows to discharge the Anode Cap. **(Refer to Fig. 3-1.)**

Connect one end of an Alligator Clip to the metal part of a flat-blade screwdriver and the other end to ground. While holding the plastic part of the insulated Screwdriver, touch the support of the Anode with the tip of the Screwdriver. A cracking noise will be heard as the voltage is discharged.

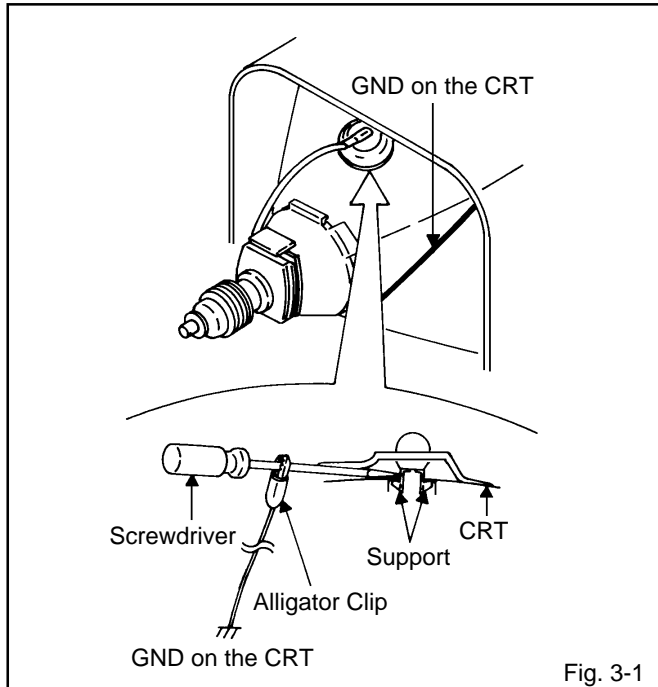

Fig. 3-1

2. Flip up the sides of the Rubber Cap in the direction of the arrow and remove one side of the support. **(Refer to Fig. 3-2.)**

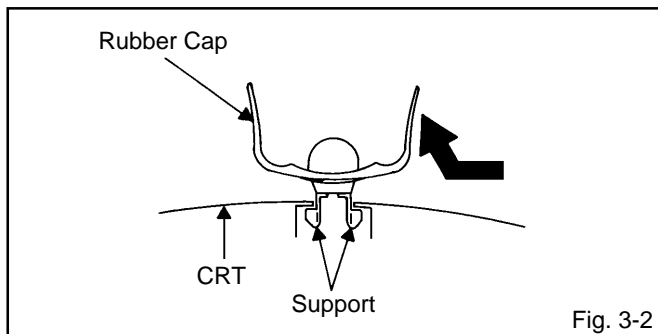

Fig. 3-2

3. After one side is removed, pull in the opposite direction to remove the other.

### NOTE

Take care not to damage the Rubber Cap.

### INSTALLATION

1. Clean the spot where the cap was located with a small amount of alcohol. **(Refer to Fig. 3-3.)**

### NOTE

Confirm that there is no dirt, dust, etc. at the spot where the cap was located.

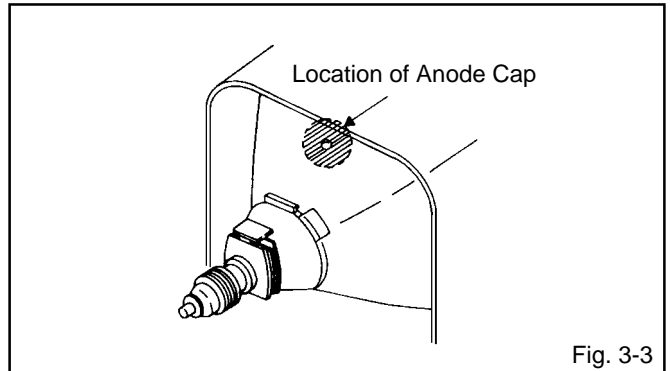

Fig. 3-3

2. Arrange the wire of the Anode Cap and make sure the wire is not twisted.
3. Turn over the Rubber Cap. **(Refer to Fig. 3-4.)**

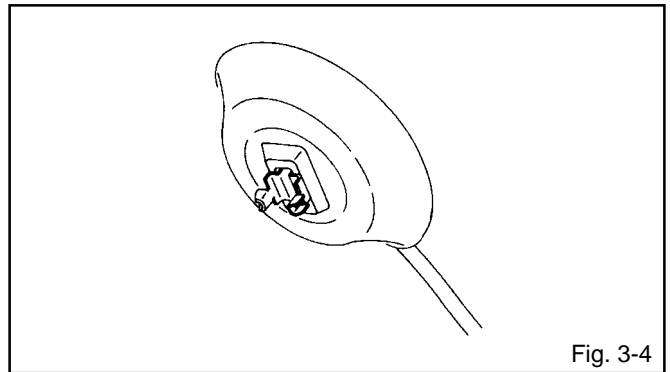

Fig. 3-4

4. Insert one end of the Anode Support into the anode button, then the other as shown in **Fig. 3-5.**

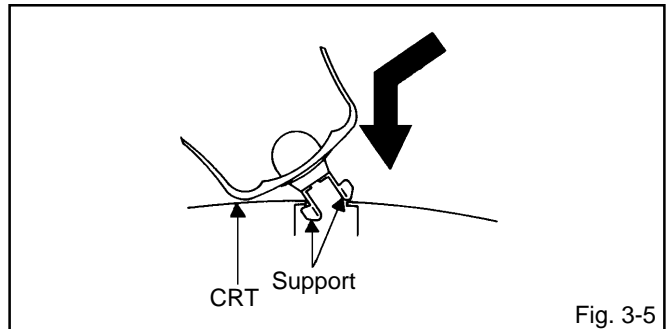

Fig. 3-5

5. Confirm that the Support is securely connected.
6. Put on the Rubber Cap without moving any parts.

# DISASSEMBLY INSTRUCTIONS

## 4. REMOVAL AND INSTALLATION OF FLAT PACKAGE IC

### REMOVAL

1. Put Masking Tape (cotton tape) around the Flat Package IC to protect other parts from any damage. (Refer to Fig. 4-1.)

#### NOTE

Masking is carried out on all the parts located within 10 mm distance from IC leads.

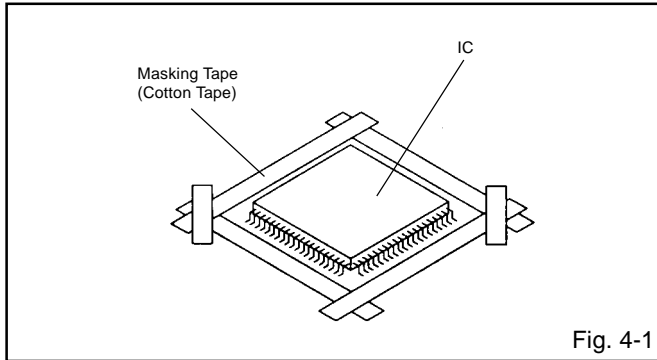

2. Heat the IC leads using a blower type IC desoldering machine. (Refer to Fig. 4-2.)

#### NOTE

Do not rotate or move the IC back and forth, until IC can move back and forth easily after desoldering the leads completely.

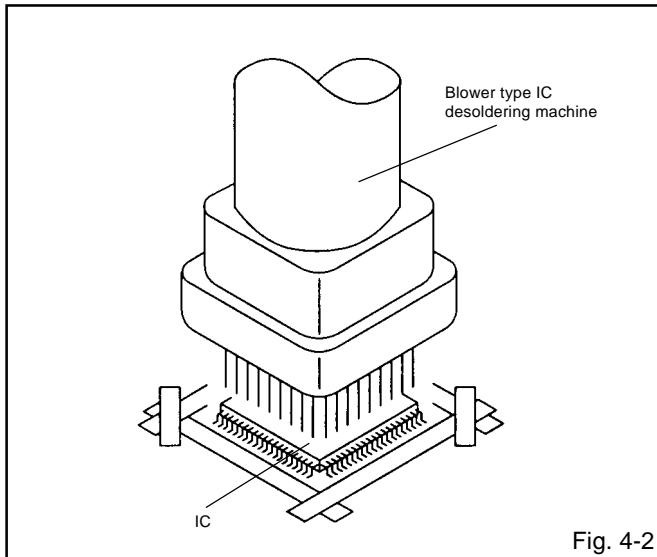

3. When IC starts moving back and forth easily after desoldering completely, pick up the corner of the IC using a tweezers and remove the IC by moving with the IC desoldering machine. (Refer to Fig. 4-3.)

#### NOTE

Some ICs on the PCB are affixed with glue, so be careful not to break or damage the foil of each IC leads or solder lands under the IC when removing it.

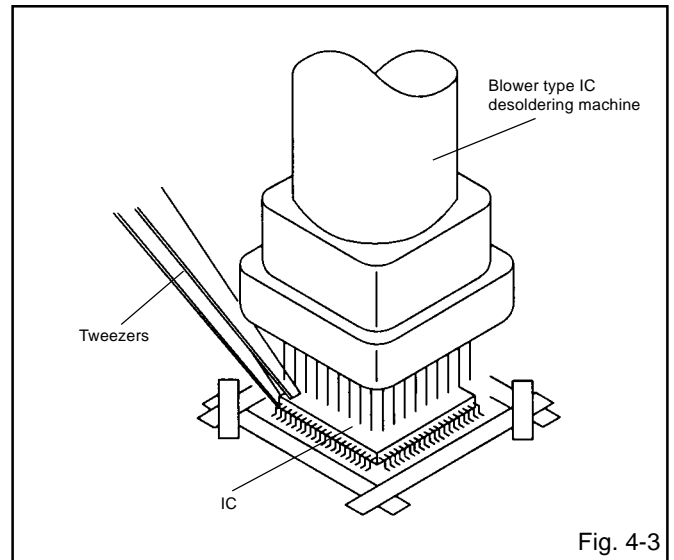

4. Peel off the Masking Tape.
5. Absorb the solder left on the pattern using the Braided Shield Wire. (Refer to Fig. 4-4.)

#### NOTE

Do not move the Braided Shield Wire in the vertical direction towards the IC pattern.

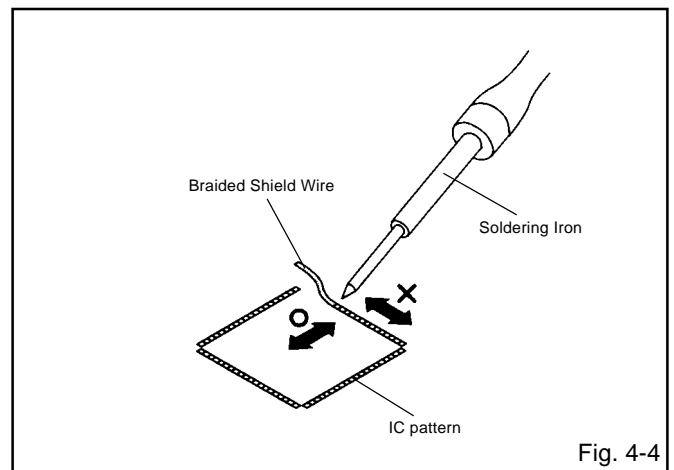

# DISASSEMBLY INSTRUCTIONS

## INSTALLATION

1. Take care of the polarity of new IC and then install the new IC fitting on the printed circuit pattern. Then solder each lead on the diagonal positions of IC temporarily. **(Refer to Fig. 4-5.)**

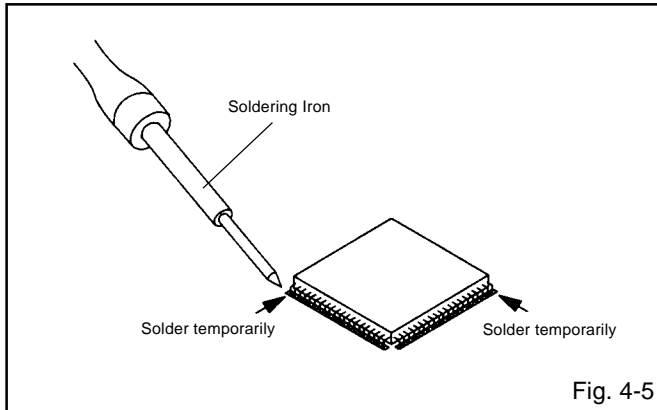

2. Supply the solder from the upper position of IC leads sliding to the lower position of the IC leads. **(Refer to Fig. 4-6.)**

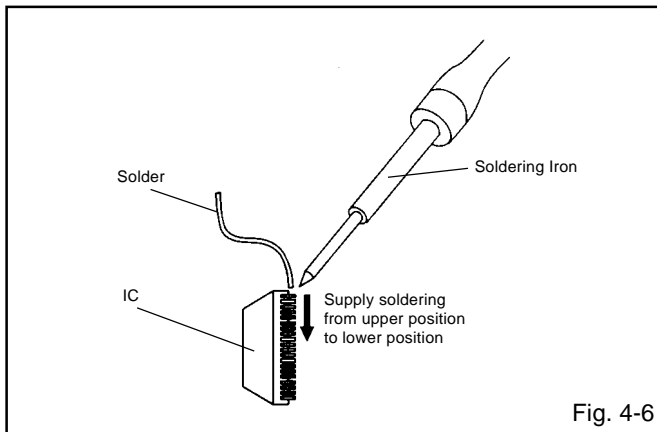

3. Absorb the solder left on the lead using the Braided Shield Wire. **(Refer to Fig. 4-7.)**

### NOTE

Do not absorb the solder to excess.

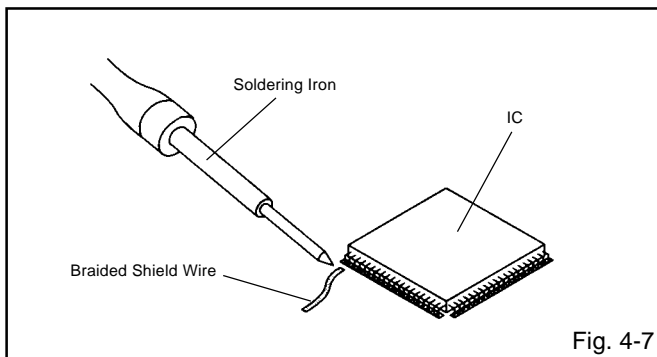

4. When bridge-soldering between terminals and/or the soldering amount are not enough, resolder using a Thin-tip Soldering Iron. **(Refer to Fig. 4-8.)**

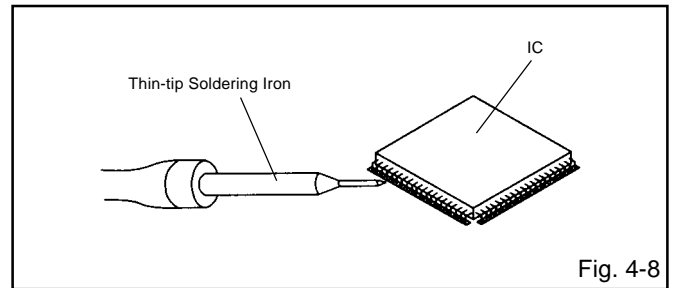

5. Finally, confirm the soldering status on four sides of the IC using a magnifying glass. Confirm that no abnormality is found on the soldering position and installation position of the parts around the IC. If some abnormality is found, correct by resoldering.

### NOTE

When the IC leads are bent during soldering and/or repairing, do not repair the bending of leads. If the bending of leads are repaired, the pattern may be damaged. So, always be sure to replace the IC in this case.

## SERVICE MODE LIST

This unit provided with the following SERVICE MODES so you can repair, examine and adjust easily.

To enter to the SERVICE MODE function, press and hold both buttons simultaneously on the main unit and on the remote control for more than a the standard time in the appropriate condition. (See below chart.)

Set Condition	Set Key	Remocon Key	Standard Time	Operations
TV mode	VOL. DOWN (Minimum)	0	2 sec.	Releasing of V-CHIP PASSWORD.
TV mode	VOL. DOWN (Minimum)	1	2 sec.	Initialization of factory TV data. NOTE: Do not use this for normal servicing. If you set factory initialization, the memories are reset such as the channel setting, and the POWER ON total hours.
DVD mode (No disc)	VOL. DOWN (Minimum)	4	2 sec.	Initialization of factory DVD data. NOTE: Do not use this for normal servicing.
TV mode	VOL. DOWN (Minimum)	6	2 sec.	Can be checked of the INITIAL DATA of MEMORY IC. Refer to the "WHEN REPLACING EEPROM (MEMORY) IC".
TV mode	VOL. DOWN (Minimum)	8	2 sec.	Check of the SUM DATA, POWER ON total hours and MICON VERSION on the screen. Refer to the "WHEN REPLACING EEPROM (MEMORY) IC".
ALL mode	VOL. DOWN (Minimum)	9	2 sec.	Display of the Adjustment MENU on the screen. Refer to the "ELECTRICAL ADJUSTMENT" (On-Screen Display Adjustment).
DVD mode (No disc)	STOP	7	3 sec.	Releasing of PARENTAL LOCK. Refer to the "PARENTAL CONTROL - RATING LEVEL".
DVD mode (STOP)	STOP	9	3 sec.	The disc cannot be taken out. Refer to the "TRAY LOCK".

### WHEN REPLACING EEPROM (MEMORY) IC

#### CONFIRMATION OF CHECK SUM, POWER ON TOTAL HOURS AND MICON VERSION

Initial total of MEMORY IC, POWER ON total hours and MICON VERSION can be checked on the screen. Total hours are displayed in 16 system of notation.

**NOTE: If you set a factory initialization, the total hours is reset to "0".**

**Please refer to "CONFIRMATION OF INITIAL DATA" when SUM DATA is not corresponding.**

1. Turn on the POWER, and set to the TV mode.
2. Set the VOLUME to minimum.
3. Press both VOL. DOWN button on the set and Channel button **(8)** on the remote control for more than 2 seconds.
4. After the confirmation of each check sum, POWER ON total hours and MICON VERSION, turn off the power.

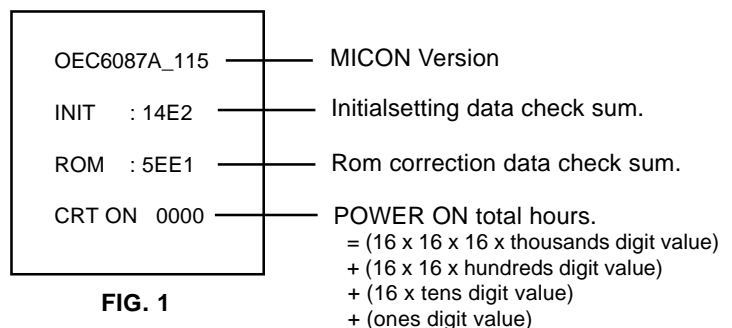

**FIG. 1**

# WHEN REPLACING EEPROM (MEMORY) IC

## CONFIRMATION OF INITIAL DATA

If a service repair is undertaken where it has been required to change the MEMORY IC, the following steps should be taken to ensure correct data settings while making reference to TABLE 1.

INI	+0	+1	+2	+3	+4	+5	+6	+7	+8	+9	+A	+B	+C	+D	+E	+F
00	80	04	EA	4C	4F	A2	33	55	35	96	23	00	D9	70	50	00
10	0C	00	00	53	05	7B	E0	50	21	74	50	00	00	10	55	35
20	05	07	09	0B	0D	0F	11	13	15	17	17	18	18	19	19	1A
30	1A	1B	1B	1C	1C	1D	1D	1E	1E	1F	1F	20	20	21	21	22
40	22	23	23	24	24	25	25	26	26	27	27	28	28	29	29	2A
50	2A	2B	2B	2C	2D	2E	2F	30	31	32	33	34	35	38	3B	3F
60	2A	3B	2B	2C	2D	2E	2F	30	---	---	---	---	---	---	---	---

Table 1

1. Turn on the POWER, and set to the TV mode.
2. Set the VOLUME to minimum.
3. Press both VOL. DOWN button on the set and Channel button (6) on the remote control for more than 2 seconds. ADDRESS and DATA should appear as FIG 1.

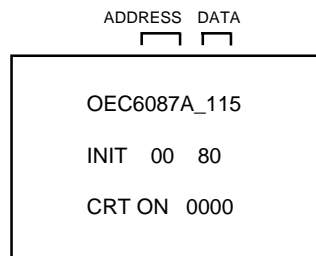

FIG. 1

4. ADDRESS is now selected and should "blink". Using the UP/DOWN button on the remote, step through the ADDRESS until Press RIGHT/LEFT button to select DATA. When DATA is selected, it will "blink".
5. Again, step through the DATA using UP/DOWN button until required DATA value has been selected.
6. Pressing RIGHT/LEFT button will take you back to ADDRESS for further selection if necessary.
7. Repeat steps 4 to 6 until all data has been checked.
8. When satisfied correct DATA has been entered, turn POWER off (return to STANDBY MODE) to finish DATA input.

**After the data input, set to the initializing of shipping.**

9. Turn POWER on.
10. Press both VOL. DOWN button on the set and Channel button (1) on the remote control for more than 2 seconds.
11. After the finishing of the initializing of shipping, the unit will turn off automatically. The unit will now have the correct DATA for the new MEMORY IC.

# ELECTRICAL ADJUSTMENTS

## 1. BEFORE MAKING ELECTRICAL ADJUSTMENTS

Read and perform these adjustments when repairing the circuits or replacing electrical parts or PCB assemblies.

### CAUTION

- Use an isolation transformer when performing any service on this chassis.
- Before removing the anode cap, discharge electricity because it contains high voltage.
- When removing a PCB or related component, after unfastening or changing a wire, be sure to put the wire back in its original position.
- When you exchange IC and Transistor with a heat sink, apply silicon grease on the contact section of the heat sink. Before applying new silicon grease, remove all the old silicon grease. (Old grease may cause damages to the IC and Transistor).

Prepare the following measurement tools for electrical adjustments.

1. Oscilloscope
2. Digital Voltmeter
3. AC Voltmeter
4. Pattern Generator
5. Multi-Sound Signal Generator

### On-Screen Display Adjustment

1. Set the VOLUME to minimum.
2. Press the VOL. DOWN button on the set and the Channel button (9) on the remote control for more than 2 seconds to appear the adjustment mode on the screen as shown in **Fig. 1-1**.

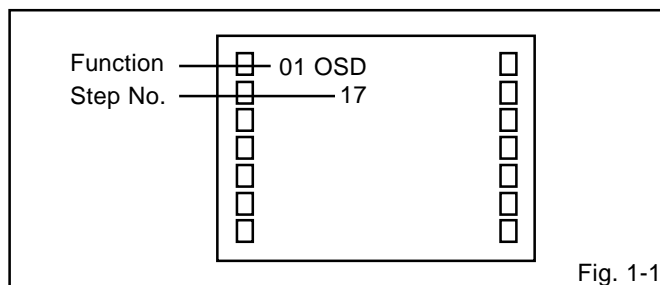

3. Use the Channel UP/DOWN button or Channel button (1-0) on the remote control to select the options shown in **Fig. 1-2**.
4. Press the MENU button on the remote control to end the adjustments.

NO.	FUNCTION	NO.	FUNCTION
01	OSD H	28	CONT. AV(MIN)
02	CUT OFF	29	COL. AV(CENT.)
03	H VCO	30	COL. AV(MAX)
04	H PHASE	31	COL. AV(MIN)
05	V SIZE	32	TINT AV
06	V POSITION	33	SHARPNESS AV
07	R DRIVE	34	BRI. DVD(CENT.)
08	B DRIVE	35	BRI. DVD(MAX)
09	R CUT OFF	36	BRI. DVD(MIN)
10	G CUT OFF	37	CONT. DVD(CENT.)
11	B CUT OFF	38	CONT. DVD(MAX)
12	BRIGHTNESS(CENT.)	39	CONT. DVD(MIN)
13	BRIGHTNESS(MAX)	40	COL. DVD(CENT.)
14	BRIGHTNESS(MIN)	41	COL. DVD(MAX)
15	CONTRAST(CENT.)	42	COL. DVD(MIN)
16	CONTRAST(MAX)	43	TINT DVD
17	CONTRAST(MIN)	44	SHARPNESS DVD
18	COLOR(CENT.)	45	BRI. GAME(CENT)
19	COLOR(MAX)	46	BRI. GAME(MAX)
20	COLOR(MIN)	47	BRI. GAME(MIN)
21	TINT	48	CONT. GAME(CENT)
22	SHARPNESS	49	CONT. GAME(MAX)
23	BRI. AV(CENT.)	50	CONT. GAME(MIN)
24	BRI. AV(MAX)	51	TUNING V MUTE
25	BRI. AV(MIN)	52	POWER ON V MUTE
26	CONT. AV(CENT.)	53	INPUT LEVEL
27	CONT. AV(MAX)	54	SEPARATION L
		55	SEPARATION H

Fig. 1-2

## 2. BASIC ADJUSTMENTS

### 2-1: CONSTANT VOLTAGE

1. Place the set in AV MODE without signal.
2. Using the remote control, set the brightness and contrast to normal position.
3. Connect the digital voltmeter to **TP401**.
4. Adjust the **VR3800** until the digital voltmeter is  $132 \pm 0.5V$ .

### 2-2: FOCUS

1. Receive the monoscope pattern.
2. Turn the Focus Volume fully counterclockwise once.
3. Adjust the **Focus Volume** until picture is distinct.

### 2-3: CUT OFF

1. Adjust the unit to the following settings.  
R CUT OFF=7F, G CUT OFF=7F, B CUT OFF=7F,  
R DRIVE=3F, B DRIVE=3F
2. Set condition is Aging Test for more than 15 minutes.
3. Set condition is AV MODE without signal.
4. Using the remote control, set the brightness and contrast to normal position.
5. Activate the adjustment mode display of **Fig. 1-1** and press the channel button (02) on the remote control to select "CUT OFF".
6. Adjust the **Screen Volume** until a dim raster is obtained.

# ELECTRICAL ADJUSTMENTS

## 2-4: WHITE BALANCE

**NOTE:** Adjust after performing CUT OFF adjustment.

1. Place the set in Aging Test for more than 15 minutes.
2. Receive the gray scale pattern from the Pattern Generator.
3. Using the remote control, set the brightness and contrast to normal position.
4. Activate the adjustment mode display of **Fig. 1-1** and press the channel button **(07)** on the remote control to select "R DRIVE".
5. Press the CH. UP/DOWN button on the remote control to select the "B DRIVE", "R CUT OFF", "G CUT OFF" or "B CUT OFF".
6. Adjust the VOL. UP/DOWN button on the remote control to whiten the B DRIVE, R CUT OFF, G CUT OFF and B CUT OFF at each step tone sections equally.
7. Perform the above adjustments 5 and 6 until the white achieved.

## 2-5: HORIZONTAL POSITION

1. Receive the monoscope pattern.
2. Using the remote control, set the brightness and contrast to normal position.
3. Activate the adjustment mode display of **Fig. 1-1** and press the channel button **(04)** on the remote control to select "HPOSI".
4. Press the RIGHT/LEFT button on the remote control until the SHIFT quantity of the OVER SCAN on right and left becomes minimum.

## 2-6: VERTICAL POSITION

1. Receive the monoscope pattern.
2. Using the remote control, set the brightness and contrast to normal position.
3. Activate the adjustment mode display of **Fig. 1-1** and press the channel button **(06)** on the remote control to select "VPOSI".
4. Check if the step No. V POSI is "02".
5. Adjust the **VR402** until the horizontal line becomes fit to notch of the shadow mask. (**Refer to Fig. 2-1**)

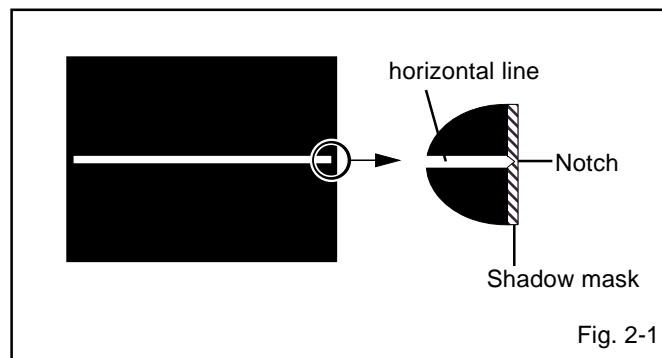

## 2-7: VERTICAL SIZE

1. Receive the monoscope pattern.
2. Using the remote control, set the brightness and contrast to normal position.
3. Activate the adjustment mode display of **Fig. 1-1** and press the channel button **(05)** on the remote control to select "VSIZE".
4. Press the RIGHT/LEFT button on the remote control until the SHIFT quantity of the OVER SCAN on upside and downside becomes  $10 \pm 1\%$ .
5. Receive a broadcast and check if the picture is normal.

## 2-8: BRIGHT CENTER

1. Receive the monoscope pattern. (RF Input)
2. Using the remote control, set the brightness and contrast to normal position.
3. Activate the adjustment mode display of **Fig. 1-1** and press the channel button **(12)** on the remote control to select "BRTC".
4. Press the RIGHT/LEFT button on the remote control until the white 0% is begin to shine.
5. Receive the monoscope pattern. (Audio Video Input)
6. Press the INPUT button on the remote control to set to the AV mode.
7. Using the remote control, set the brightness and contrast to normal position.
8. Activate the adjustment mode display of **Fig. 1-1** and press the channel button **(23)** on the remote control to select "BRTCA".
9. Press the RIGHT/LEFT button on the remote control until the white 0% is begin to shine.
10. Press the TV/DVD button on the remote control to set to the DVD mode.
11. Activate the adjustment mode display of **Fig. 1-1** and press the channel button **(34)** on the remote control to select "BRTCD".
12. Press the RIGHT/LEFT button on the remote control to set the same step numbers as the AV.
13. Press the INPUT button on the remote control to set to the GAME mode.
14. Activate the adjustment mode display of **Fig. 1-1** and press the channel button **(45)** on the remote control to select "BRTCG".
15. Press the RIGHT/LEFT button on the remote control to set the same the same step numbers as the AV.

## 2-9: LEVEL

1. Receive the VHF HIGH (70dB).
2. Connect the AC voltmeter to **pin 6 of CP101**.
3. Activate the adjustment mode display of **Fig. 1-1** and press the channel button **(63)** on the remote control to select "LVL".
4. Press the RIGHT/LEFT button on the remote control until the AC voltmeter is  $75 \pm 2\text{mV}$ .

# ELECTRICAL ADJUSTMENTS

## 2-10: OSD POSITION

1. Activate the adjustment mode display of **Fig. 1-1**.
2. Press the RIGHT/LEFT button on the remote control until the difference of A and B becomes minimum.  
**(Refer to Fig. 2-2)**

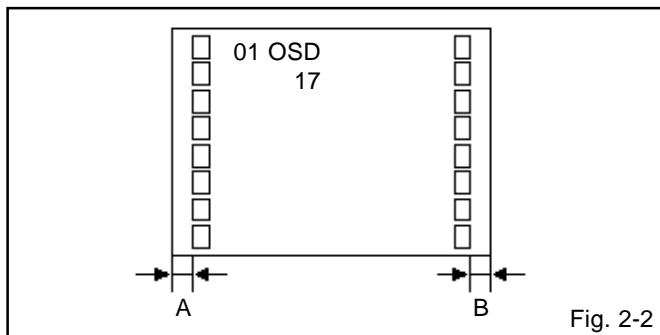

## 2-11: TINT

1. Receive the color bar pattern. (RF Input)
2. Using the remote control, set the brightness, contrast, color and tint to normal position.
3. Connect the oscilloscope to **TP022**.
4. Activate the adjustment mode display of **Fig. 1-1** and press the channel button (**21**) on the remote control to select "TNTC".
5. Press the RIGHT/LEFT button on the remote control until the section "A" becomes a straight line.  
**(Refer to Fig. 2-3)**
6. Receive the color bar pattern. (Audio Video Input)
7. Press the INPUT button on the remote control to set to the AV mode.
8. Using the remote control, set the brightness, contrast, color and tint to normal position.
9. Activate the adjustment mode display of **Fig. 1-1** and press the channel button (**32**) on the remote control to select "TNTCA".
10. Press the RIGHT/LEFT button on the remote control until the section "A" becomes a straight line.  
**(Refer to Fig. 2-3)**
11. Press the TV/DVD button on the remote control to set to the DVD mode.
12. Using the remote control, set the brightness, contrast, color and tint to normal position.
13. Connect the oscilloscope to **TP022**.
14. Activate the adjustment mode display of **Fig. 1-1** and press the channel button (**43**) on the remote control to select "TNTCD".
15. Press the RIGHT/LEFT button on the remote control to set the same step numbers as the AV.

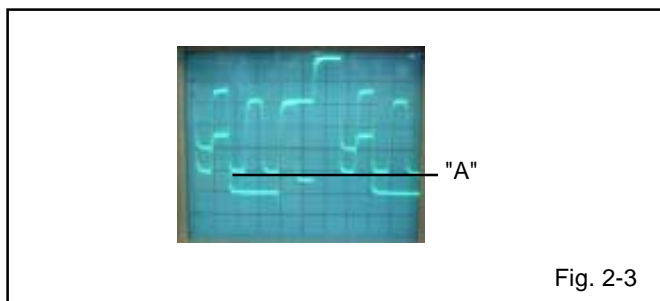

## 2-12: COLOR CENTER

1. Receive the color bar pattern. (RF Input)
2. Using the remote control, set the brightness, contrast, color and tint to normal position.
3. Connect the oscilloscope to **TP024**.
4. Activate the adjustment mode display of **Fig. 1-1** and press the channel button (**18**) on the remote control to select "COLC".
5. Adjust the VOLTS RANGE VARIABLE knob of the oscilloscope until the range between white 100% and 0% is set to 4 scales on the screen of the oscilloscope.
6. Press the RIGHT/LEFT button on the remote control until the red color level is adjusted to  $120 \pm 5\%$  of the white level.  
**(Refer to Fig. 2-4)**
7. Receive the color bar pattern. (Audio Video Input)
8. Press the INPUT button on the remote control to set to the AV mode.
9. Using the remote control, set the brightness, contrast, color and tint to normal position.
10. Connect the oscilloscope to **TP024**.
11. Activate the adjustment mode display of **Fig. 1-1** and press the channel button (**29**) on the remote control to select "COLCA".
12. Adjust the VOLTS RANGE VARIABLE knob of the oscilloscope until the range between white 100% and 0% is set to 4 scales on the screen of the oscilloscope.
13. Press the RIGHT/LEFT button on the remote control until the red color level is adjusted to  $110 \pm 5\%$  of the white level.  
**(Refer to Fig. 2-4)**
14. Press the TV/DVD button on the remote control to set to the DVD mode.
15. Activate the adjustment mode display of **Fig. 1-1** and press the channel button (**40**) on the remote control to select "COLCD".
16. Press the RIGHT/LEFT button on the remote control to increase the step numbers by 5 steps to the AV.

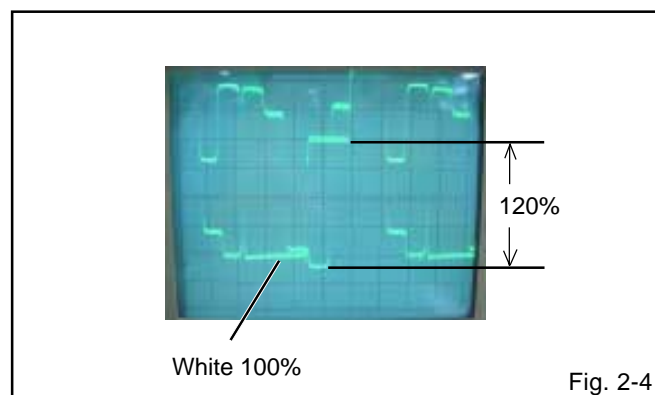

## ELECTRICAL ADJUSTMENTS

### 2-13: CONTRAST MAX

1. Activate the adjustment mode display of **Fig. 1-1** and press the channel button **(16)** on the remote control to select "CNTX".
2. Press the RIGHT/LEFT button on the remote control until the contrast step No. becomes "4E"
3. Receive a broadcast and check if the picture is normal.
4. Press the INPUT button on the remote control to set to the AV mode.
5. Activate the adjustment mode display of **Fig. 1-1** and press the channel button **(27)** on the remote control to select "CNTXA".
6. Press the RIGHT/LEFT button on the remote control until the contrast step No. becomes "4E"
7. Receive a broadcast and check if the picture is normal.
8. Press the TV/DVD button on the remote control to set to the DVD mode.
9. Activate the adjustment mode display of **Fig. 1-1** and press the channel button **(38)** on the remote control to select "CNTXD".
10. Press the RIGHT/LEFT button on the remote control to increase the step numbers by 5 steps to the AV.
11. Press the INPUT button on the remote control to set to the GAME mode.
12. Activate the adjustment mode display of **Fig. 1-1** and press the channel button **(49)** on the remote control to select "CNTXG".
13. Press the RIGHT/LEFT button on the remote control to set the same the same step numbers as the AV.

### 2-14: SEPARATION

1. Set the multi-sound signal generator L-ch=1KHz, R-ch =Non input and receive the RF signal.
2. Connect the oscilloscope to the **SP351 code**.
3. Press the AUDIO SELECT button on the remote control to set to the stereo mode.
4. Activate the adjustment mode display of **Fig. 1-1** and press the channel button **(54)** on the remote control to select "SEPAL".
5. Press the RIGHT/LEFT button on the remote control to adjust it until the R-ch output becomes minimum.
6. Press the CH UP button 1 time to set to "SEPAH" mode.
7. Press the RIGHT/LEFT button on the remote control to adjust it until the R-ch output becomes minimum.
8. Set the multi-sound signal generator L-ch=Non input, R-ch=1KHz and receive the RF signal.
9. Connect the oscilloscope to the **SP352 code**. Then perform the above adjustments 3~7.

### 2-15: Confirmation of Fixed Value (Step No.)

Please check if the fixed values of the each of the adjustment items are set correctly referring below.

NO.	FUNCTION	STEP NO.
03	H VCO	04
11	B CUT OFF	7F
13	BRIGHTNESS(MAX)	70
14	BRIGHTNESS(MIN)	30
15	CONTRAST(CENT.)	2A
17	CONTRAST(MIN)	1D
19	COLOR(MAX)	50
20	COLOR(MIN)	00
22	SHARPNESS	2B
24	BRI. AV(MAX)	70
25	BRI. AV(MIN)	30
26	CONT. AV(CENT.)	2A
28	CONT. AV(MIN)	1D
30	COL. AV(MAX)	50
31	COL. AV(MIN)	00
33	SHARPNESS AV	2B
35	BRI. DVD(MAX)	70
36	BRI. DVD(MIN)	30
37	CONT. DVD(CENT.)	2A
39	CONT. DVD(MIN)	1D
41	COL. DVD(MAX)	50
42	COL. DVD(MIN)	00
44	SHARPNESS DVD	2B
46	BRI. GAME(MAX)	70
47	BRI. GAME(MIN)	30
48	CONT. GAME(CENT)	2A
50	CONT. GAME(MIN)	1D
51	TUNING V MUTE	00
52	POWER ON V MUTE	40

# ELECTRICAL ADJUSTMENTS

## 3. PURITY AND CONVERGENCE ADJUSTMENTS

### NOTE

1. Turn the unit on and let it warm up for at least 30 minutes before performing the following adjustments.
2. Place the CRT surface facing east or west to reduce the terrestrial magnetism.
3. Turn ON the unit and demagnetize with a Degauss Coil.

### 3-1: STATIC CONVERGENCE (ROUGH ADJUSTMENT)

1. Tighten the screw for the magnet. Refer to the adjusted CRT for the position. **(Refer to Fig. 3-1)**  
If the deflection yoke and magnet are in one body, untighten the screw for the body.
2. Receive the green raster pattern from the color bar generator.
3. Slide the deflection yoke until it touches the funnel side of the CRT.
4. Adjust center of screen to green, with red and blue on the sides, using the pair of purity magnets.
5. Switch the color bar generator from the green raster pattern to the crosshatch pattern.
6. Combine red and blue of the 3 color crosshatch pattern on the center of the screen by adjusting the pair of 4 pole magnets.
7. Combine red/blue (magenta) and green by adjusting the pair of 6 pole magnets.
8. Adjust the crosshatch pattern to change to white by repeating steps 6 and 7.

### 3-2: PURITY

#### NOTE

Adjust after performing adjustments in section 3-1.

1. Receive the green raster pattern from color bar generator.
2. Adjust the pair of purity magnets to center the color on the screen.  
Adjust the pair of purity magnets so the color at the ends are equally wide.
3. Move the deflection yoke backward (to neck side) slowly, and stop it at the position when the whole screen is green.
4. Confirm red and blue colors.
5. Adjust the slant of the deflection yoke while watching the screen, then tighten the fixing screw.

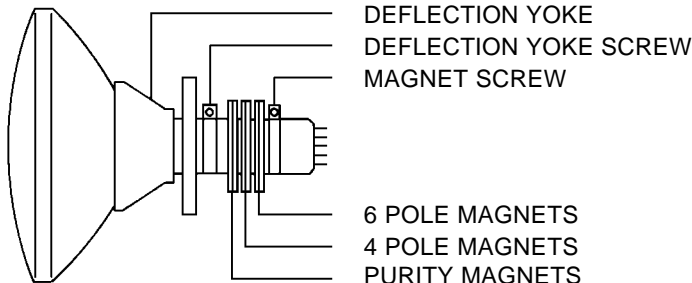

Fig. 3-1

### 3-3: STATIC CONVERGENCE

#### NOTE

Adjust after performing adjustments in section 3-2.

1. Receive the crosshatch pattern from the color bar generator.
2. Combine red and blue of the 3 color crosshatch pattern on the center of the screen by adjusting the pair of 4 pole magnets.
3. Combine red/blue (magenta) and green by adjusting the pair of 6 pole magnets.

### 3-4: DYNAMIC CONVERGENCE

#### NOTE

Adjust after performing adjustments in section 3-3.

1. Adjust the differences around the screen by moving the deflection yoke upward/downward and right/left. **(Refer to Fig. 3-2-a)**
2. Insert three wedges between the deflection yoke and CRT funnel to fix the deflection yoke. **(Refer to Fig. 3-2-b)**

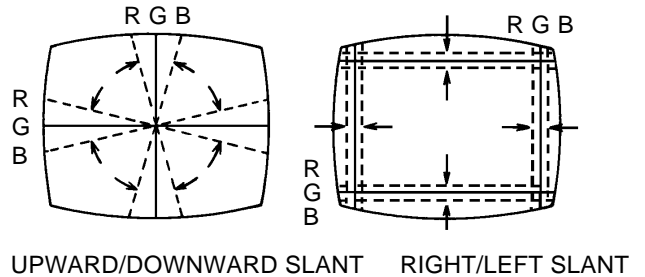

Fig. 3-2-a

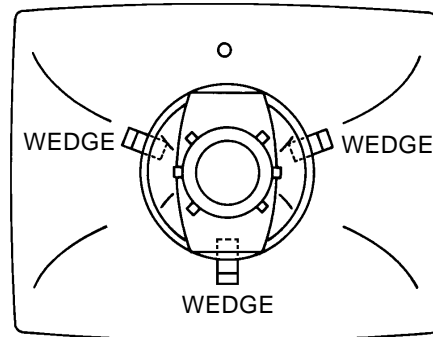
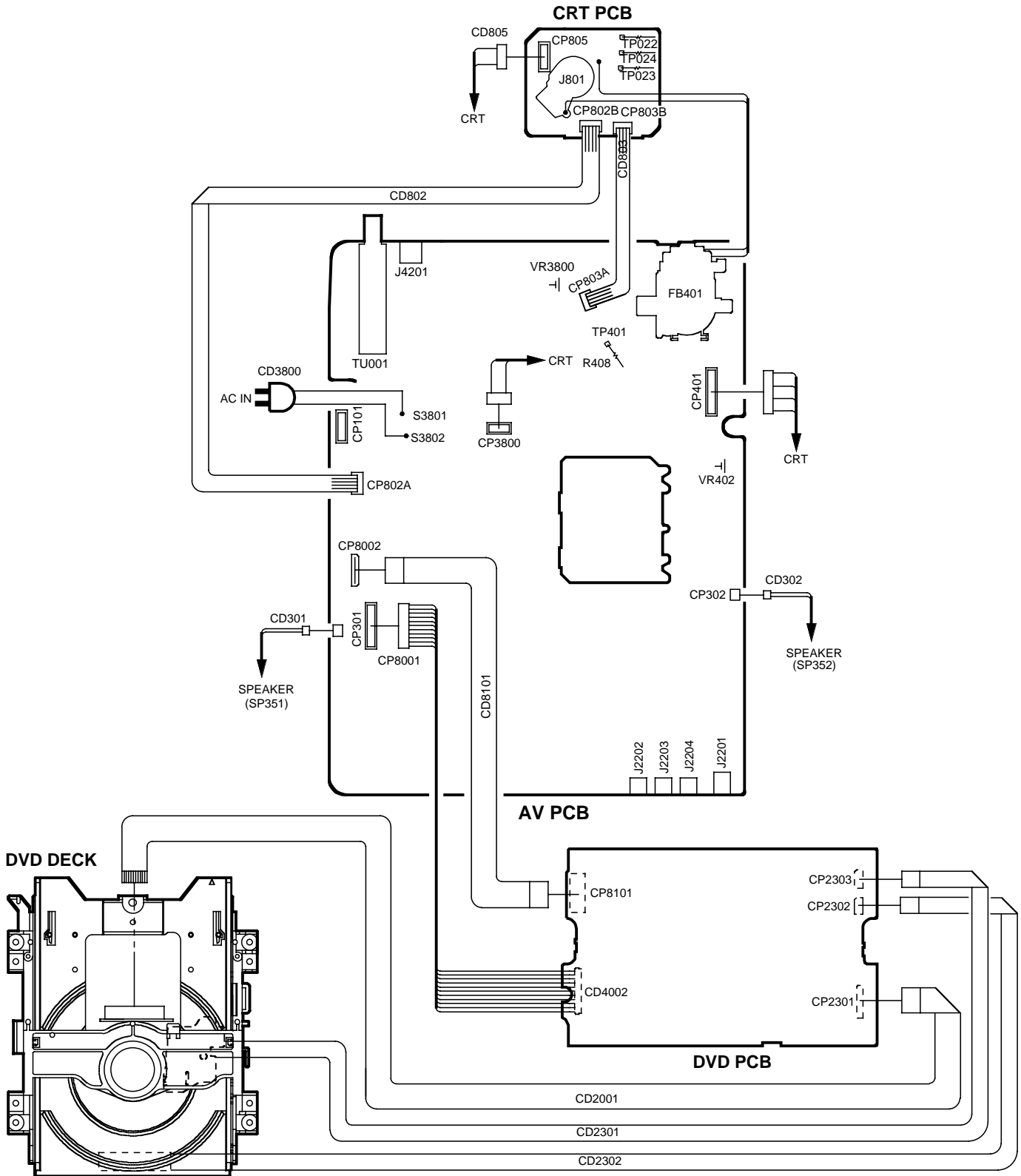

Fig. 3-2-b

# ELECTRICAL ADJUSTMENTS

## 4. ELECTRICAL ADJUSTMENT PARTS LOCATION GUIDE (WIRING CONNECTION)



# DVD BLOCK DIAGRAM

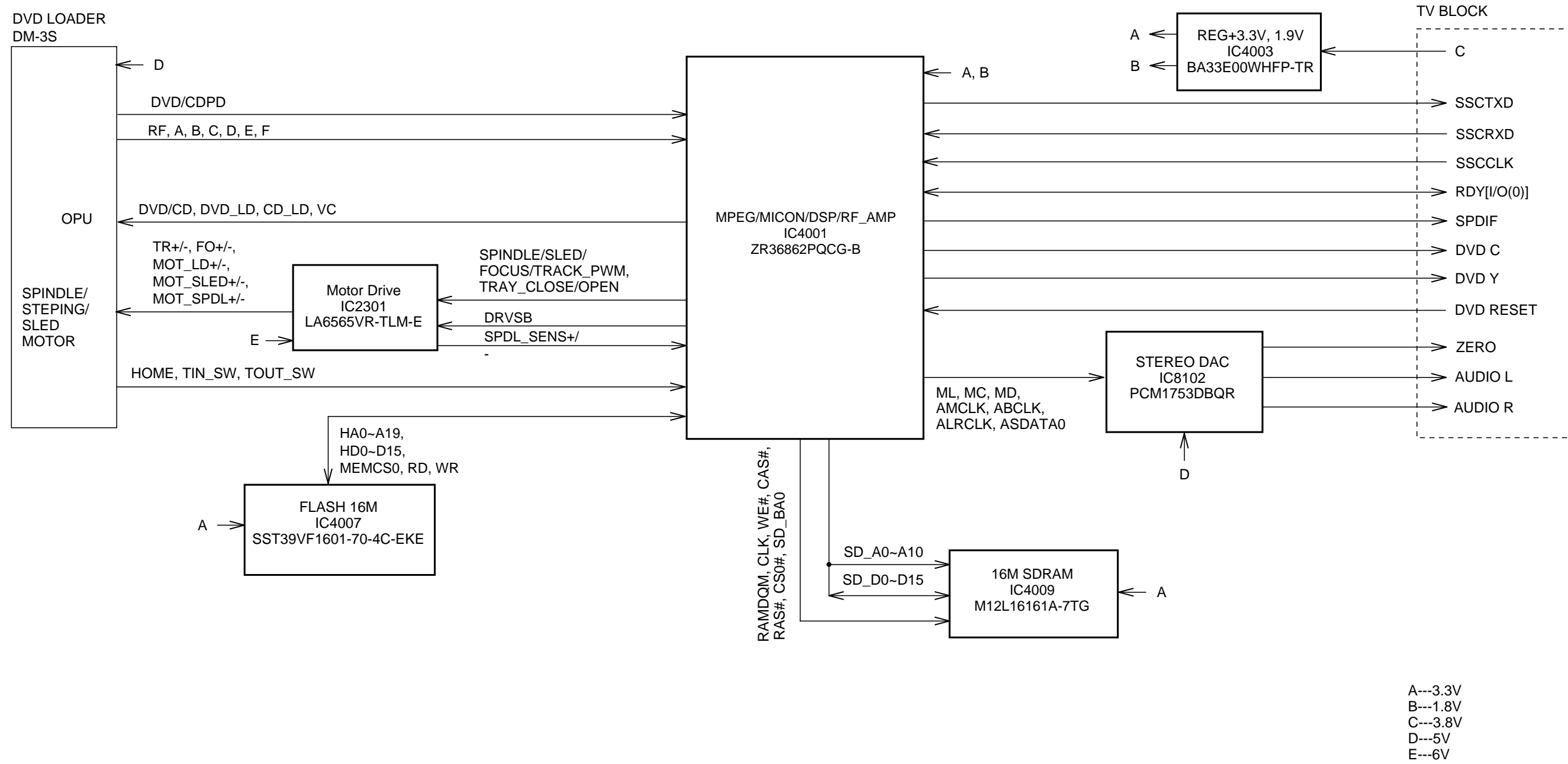

# TV BLOCK DIAGRAM

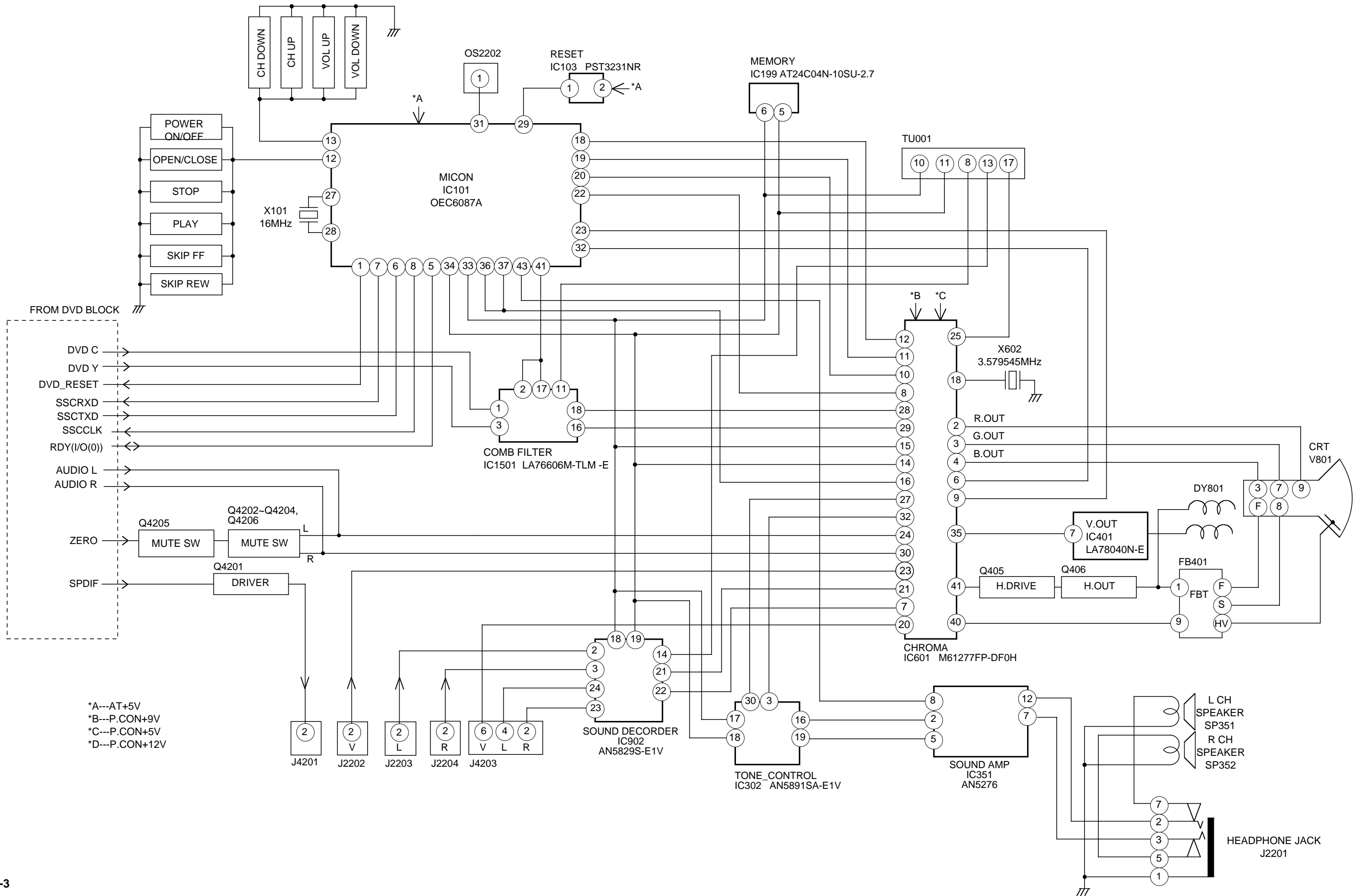

# POWER BLOCK DIAGRAM

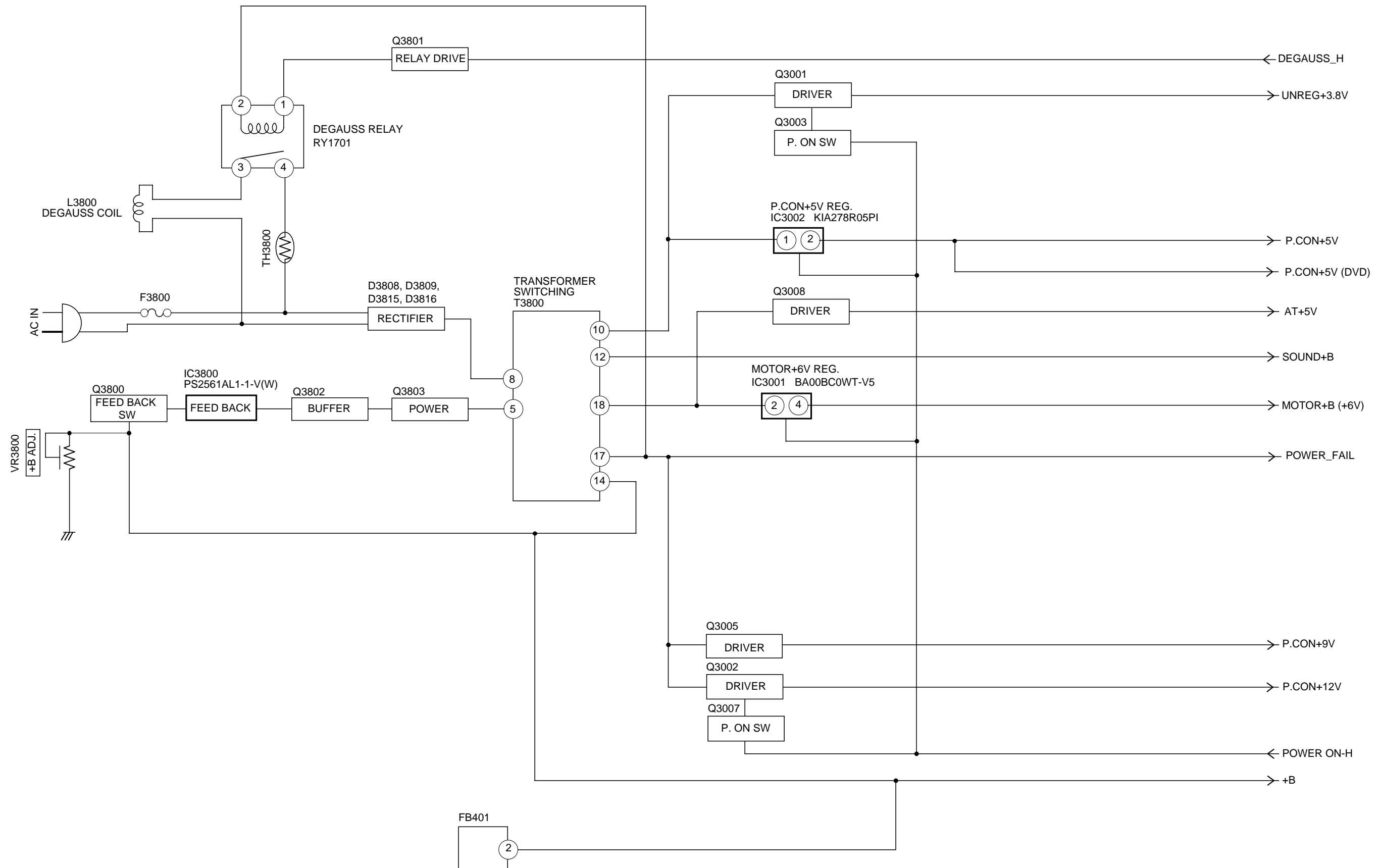

PRINTED CIRCUIT BOARDS

DVD (TOP SIDE)

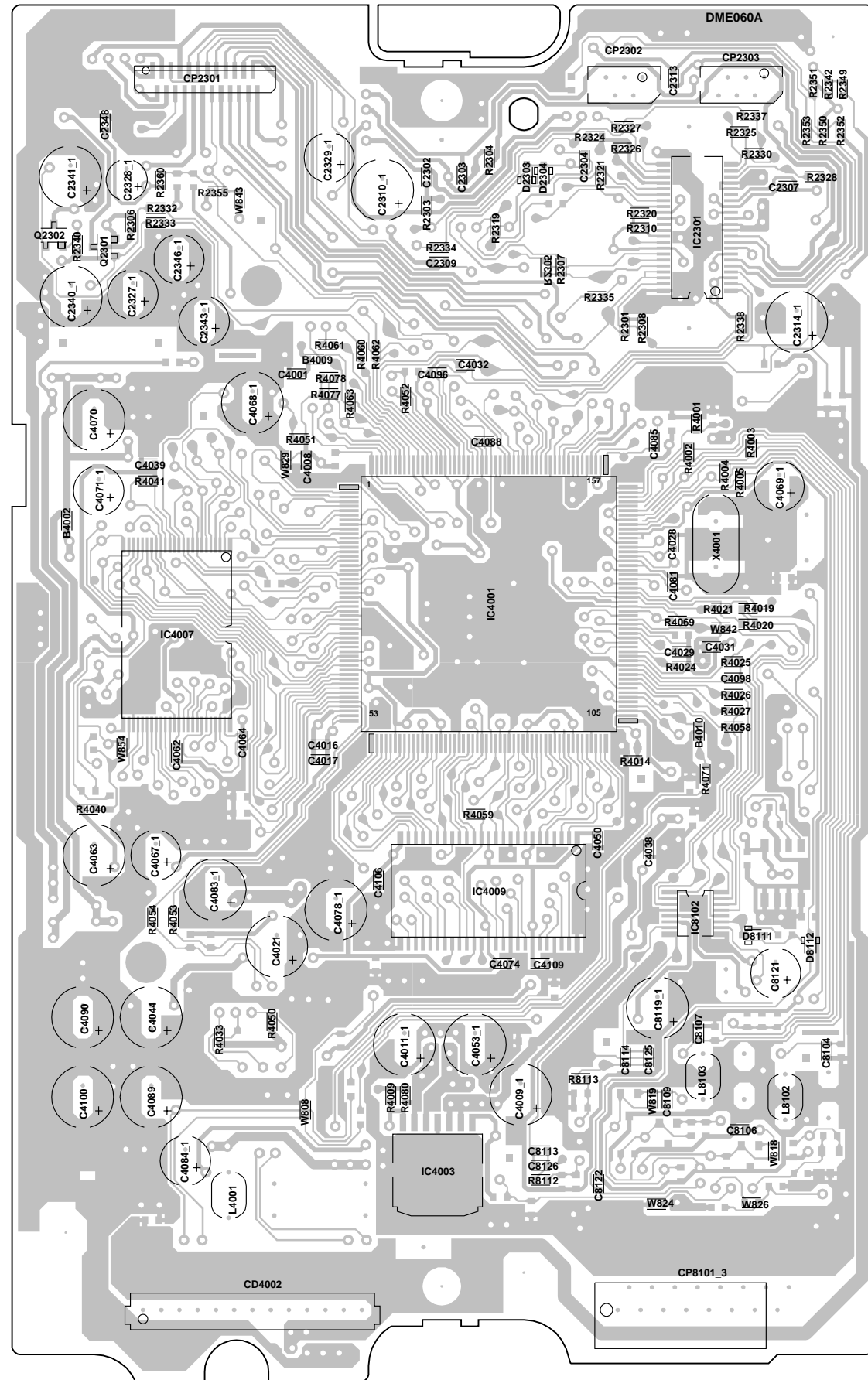

DVD (BOTTOM SIDE)

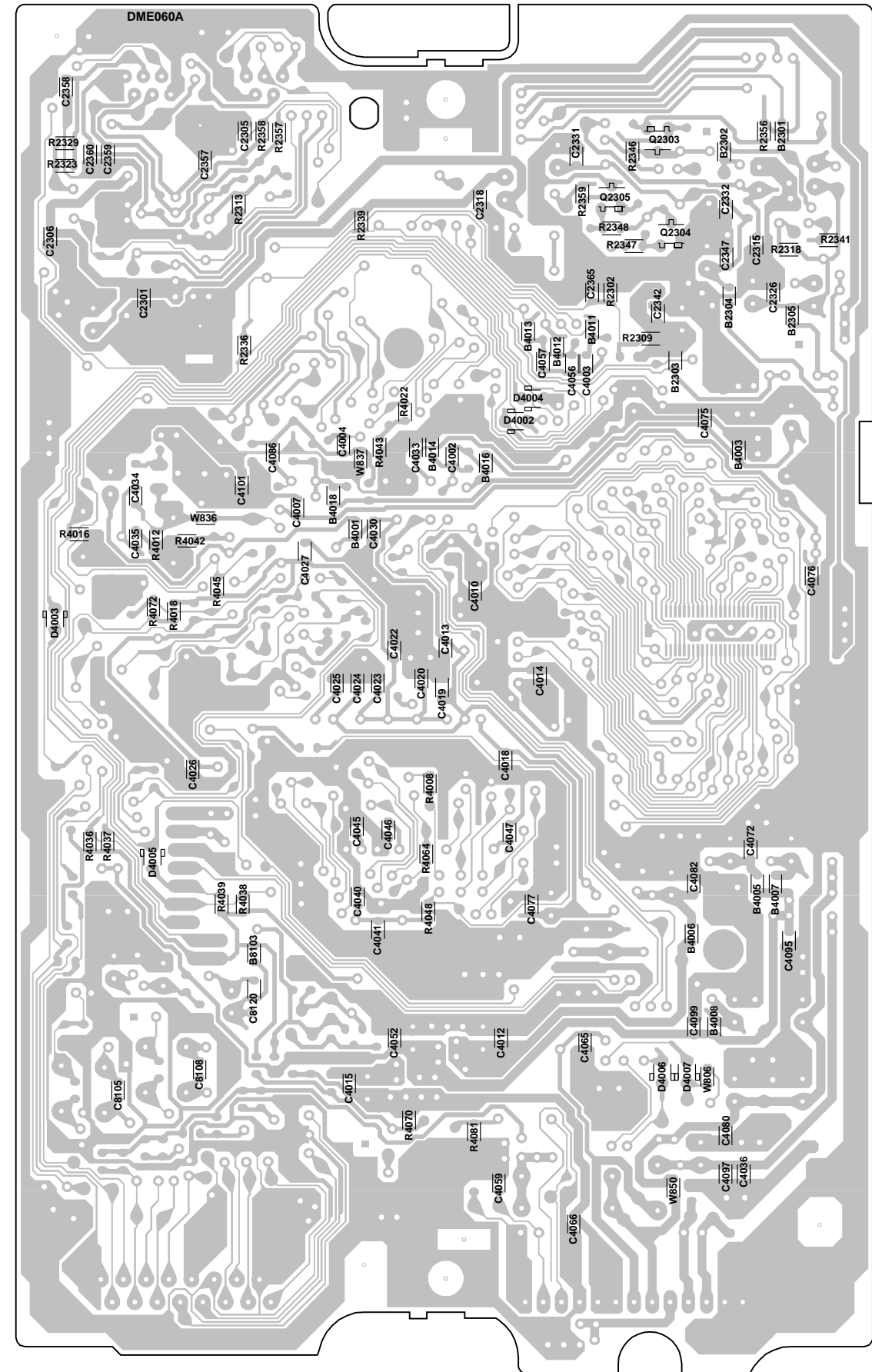

**PRINTED CIRCUIT BOARDS  
AV/CRT (INSERTED PARTS)  
SOLDER SIDE**

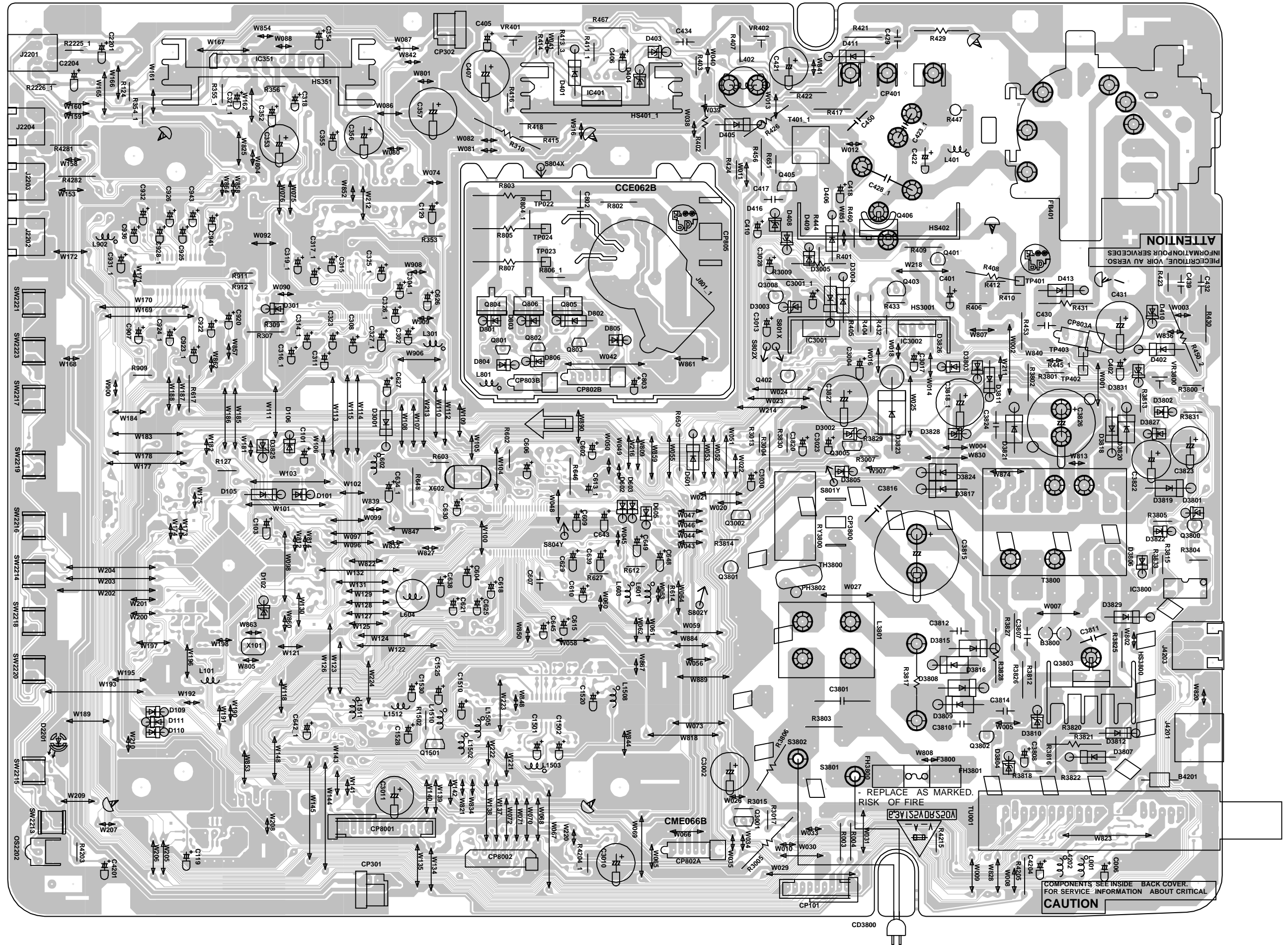



# PRINTED CIRCUIT BOARDS

## LOADING MOTOR (INSERTED PARTS) SOLDER SIDE

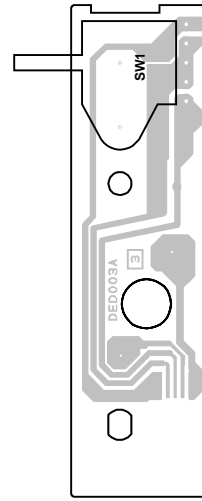

## LOADING MOTOR (CHIP MOUNTED PARTS) SOLDER SIDE

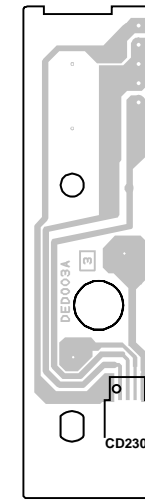

## SW SOLDER SIDE

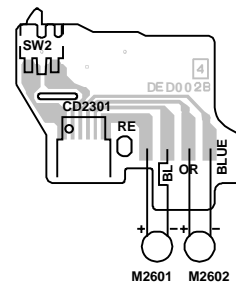



# MEMORY SCHEMATIC DIAGRAM (DVD PCB)

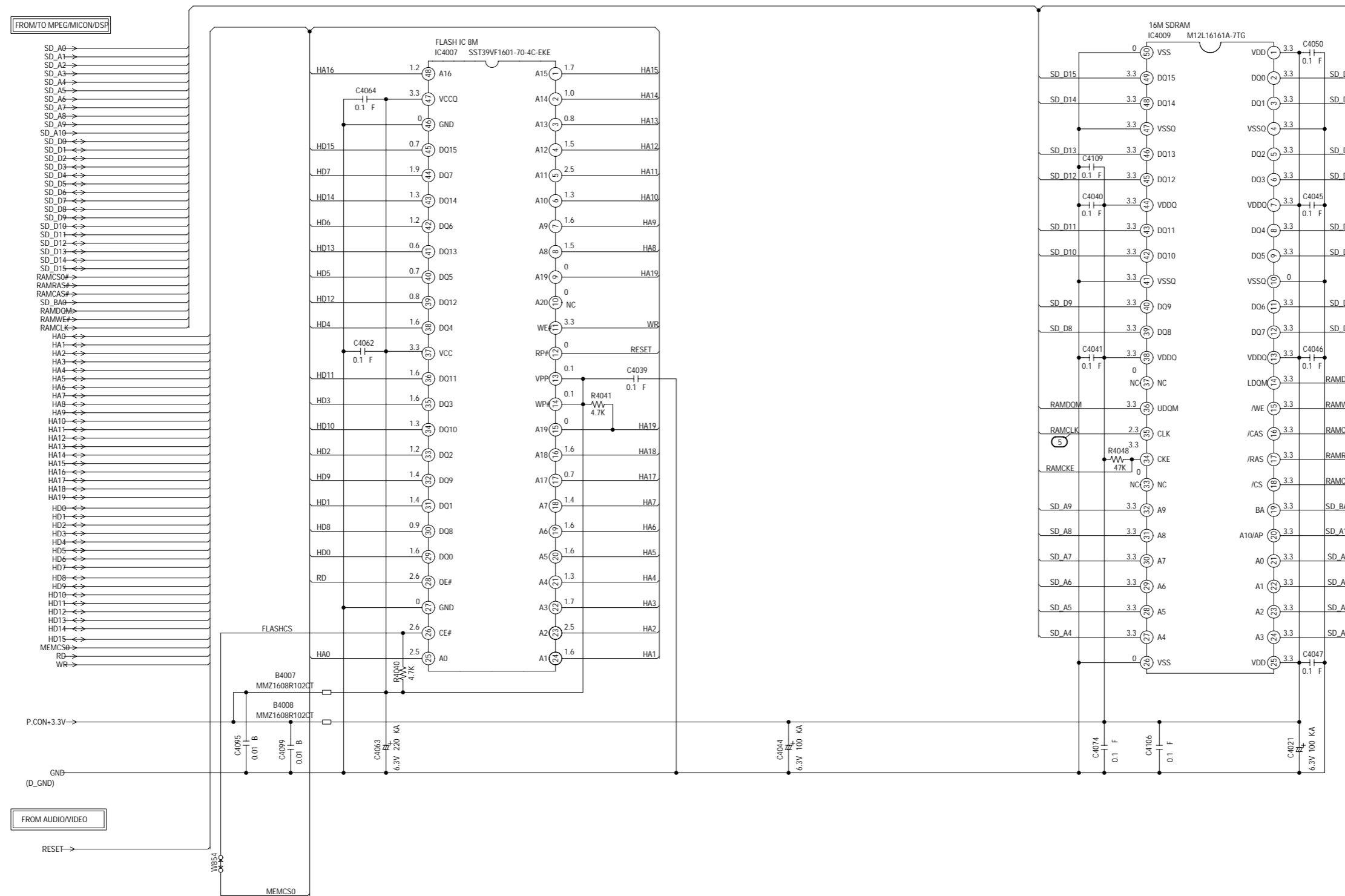

NOTE: THIS SCHEMATIC DIAGRAM IS THE LATEST AT THE TIME OF PRINTING AND SUBJECT TO CHANGE WITHOUT NOTICE.

NOTE: THE DC VOLTAGE EACH PART WAS MEASURED WITH THE DIGITAL TESTER DURING PLAYBACK.

PCB130  
DME060

# MOTOR DRIVE SCHEMATIC DIAGRAM (DVD PCB)

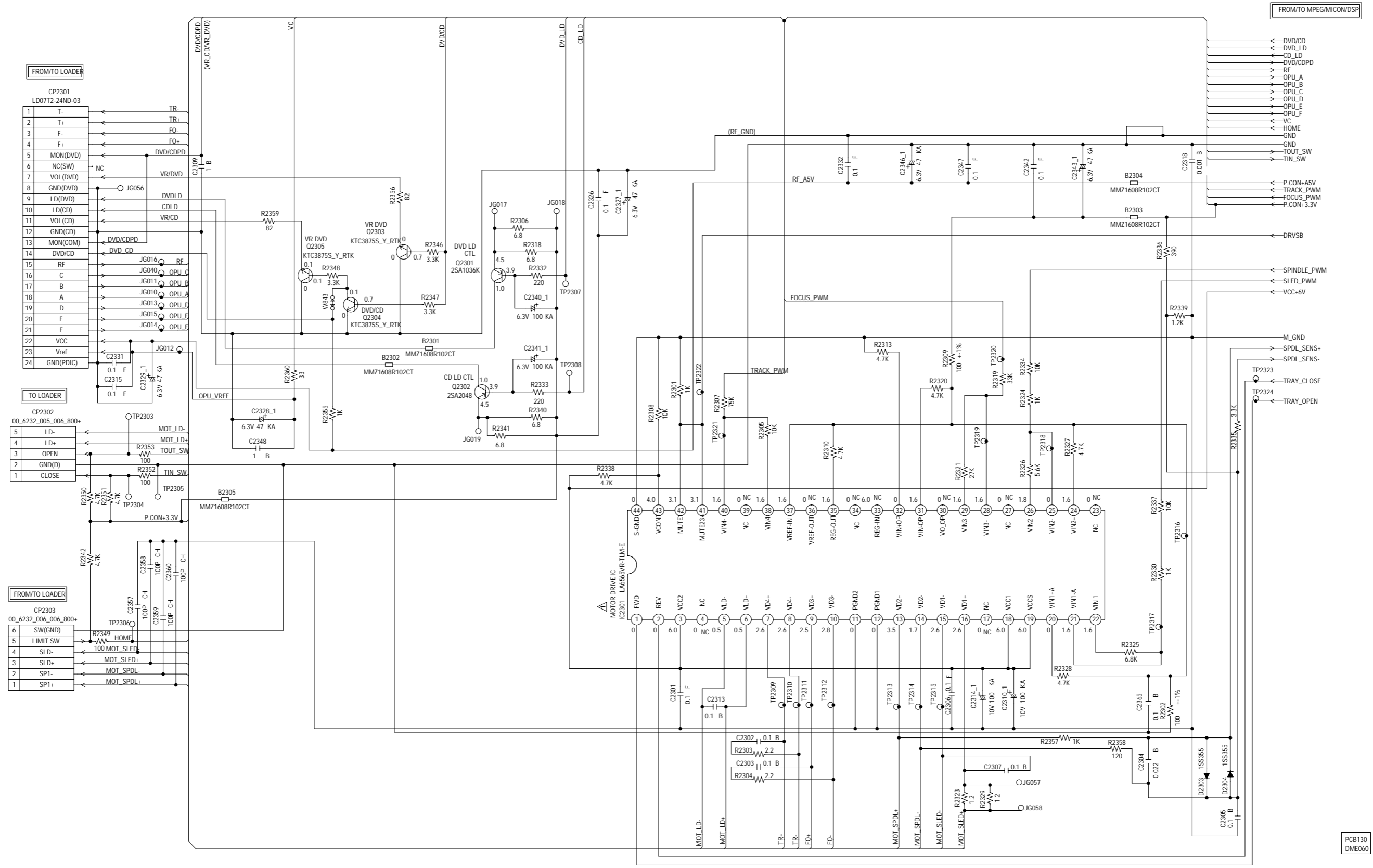

NOTE: THIS SCHEMATIC DIAGRAM IS THE LATEST AT THE TIME OF PRINTING AND SUBJECT TO CHANGE WITHOUT NOTICE.

NOTE: THE DC VOLTAGE EACH PART WAS MEASURED WITH THE DIGITAL TESTER DURING PLAYBACK.

**ATTENTION** LES PIÈCES RÉPARÉES PAR UN ÉTANT DANGEREUSES AN POINT DE VUE SECURITE N'UTILISER QUE CELLES DÉCRITES DANS LA NOMENCLATURE DES PIÈCES

**CAUTION** SINCE THESE PARTS MARKED BY ARE CRITICAL FOR SAFETY, USE ONES DESCRIBED IN PARTS LIST ONLY.

PCB130  
DME060

# AUDIO/VIDEO SCHEMATIC DIAGRAM (DVD PCB)

FROM/TO MPEG/MICON/DSP

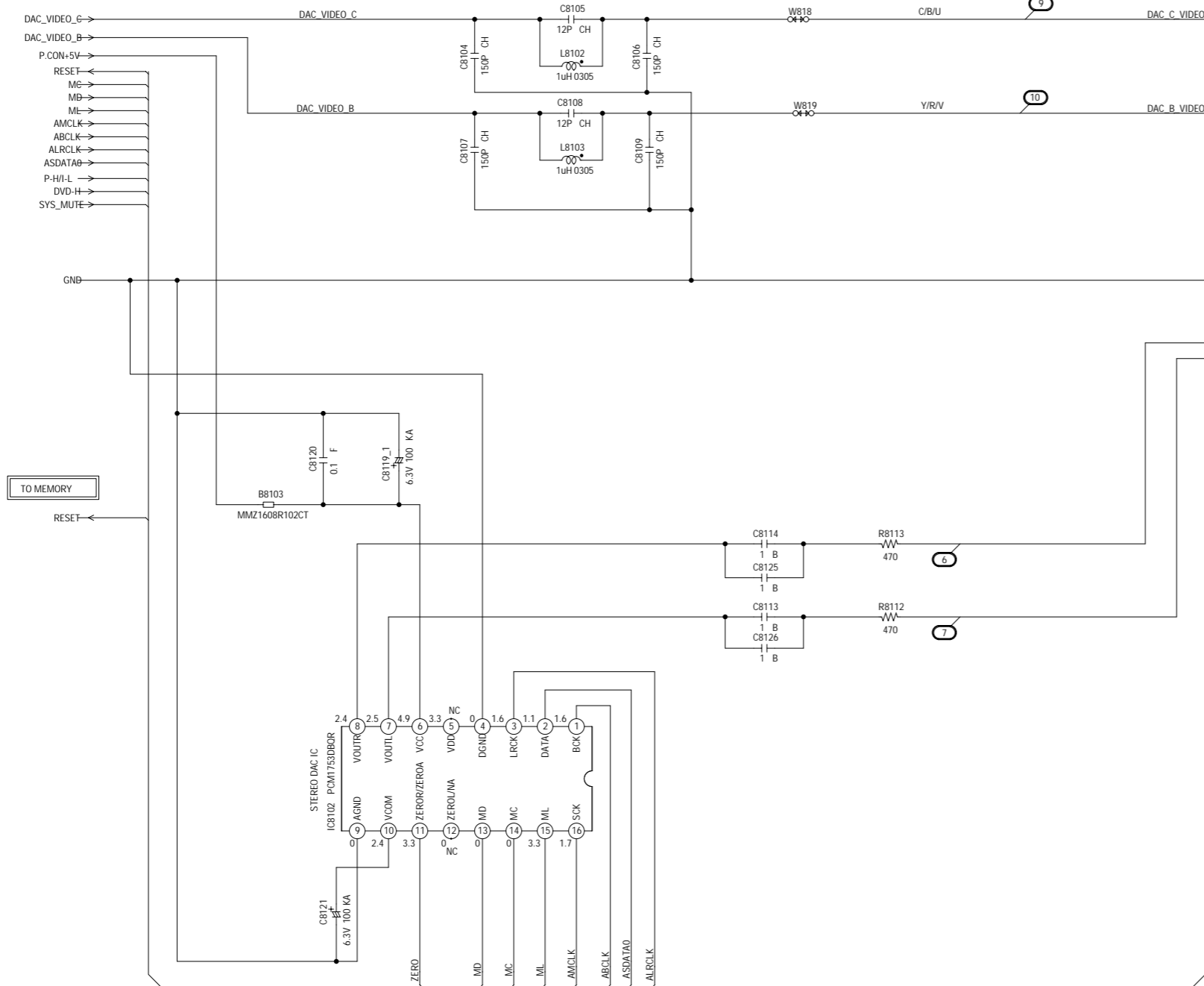

TO MEMORY

FROM/TO REGULATOR

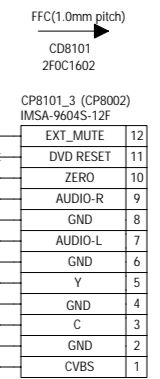

PCB130  
DME060

NOTE: THIS SCHEMATIC DIAGRAM IS THE LATEST AT THE TIME OF PRINTING AND SUBJECT TO CHANGE WITHOUT NOTICE.

NOTE: THE DC VOLTAGE EACH PART WAS MEASURED WITH THE DIGITAL TESTER DURING PLAYBACK.

# REGULATOR SCHEMATIC DIAGRAM

(AV PCB)

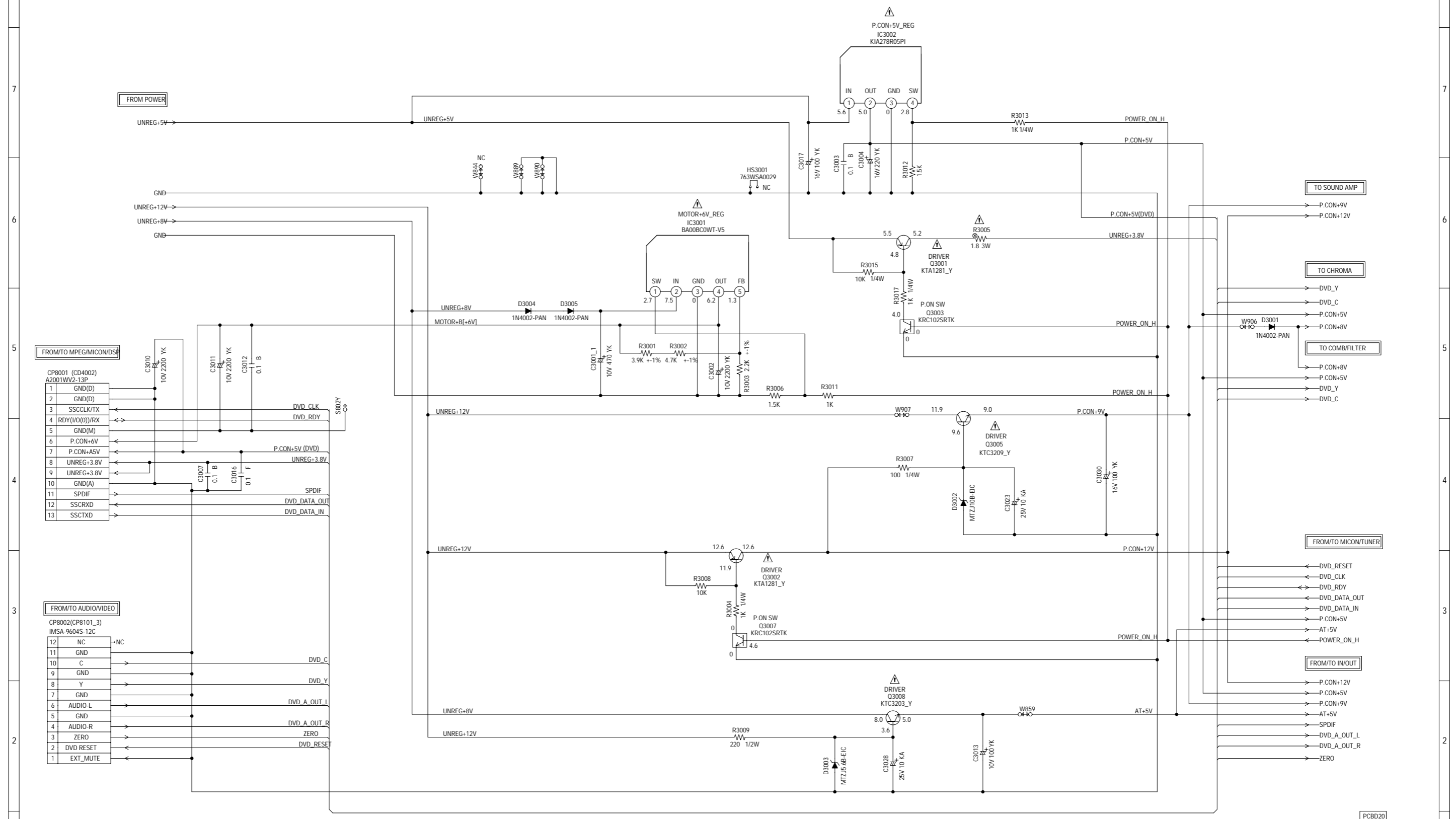

FROM/TO MPEG/MICON/DSR

1	GND(D)	DVD_CLK
2	GND(D)	DVD_RDY
3	SSCLK/TX	
4	RDY(I/O(D))/RX	
5	GND(M)	
6	P.CON+6V	
7	P.CON+A5V	P.CON+5V(DVD)
8	UNREG+3.8V	UNREG+3.8V
9	UNREG+3.8V	
10	GND(A)	
11	SPDIF	SPDIF
12	SSCRXD	DVD_DATA_OUT
13	SSCTXD	DVD_DATA_IN

FROM/TO AUDIO/VIDEO

12	NC	DVD_C
11	GND	DVD_Y
10	C	
9	GND	DVD_A_OUT_L
8	Y	
7	GND	DVD_A_OUT_R
6	AUDIO-L	
5	GND	ZERO
4	AUDIO-R	
3	ZERO	DVD_RESET
2	DVD RESET	
1	EXT_MUTE	

TO SOUND AMP

TO CHROMA

TO COMB/FILTER

P.CON+9V	
P.CON+12V	
UNREG+3.8V	
POWER_ON_H	
P.CON+8V	
P.CON+5V	
DVD_Y	
DVD_C	
P.CON+5V	
DVD_Y	
DVD_C	

FROM/TO MICON/TUNER

FROM/TO IN/OUT

DVD_RESET	
DVD_CLK	
DVD_RDY	
DVD_DATA_OUT	
DVD_DATA_IN	
P.CON+5V	
AT+5V	
POWER_ON_H	
P.CON+12V	
P.CON+5V	
P.CON+9V	
AT+5V	
SPDIF	
DVD_A_OUT_L	
DVD_A_OUT_R	
ZERO	

NOTE: THIS SCHEMATIC DIAGRAM IS THE LATEST AT THE TIME OF PRINTING AND SUBJECT TO CHANGE WITHOUT NOTICE.

NOTE: THE DC VOLTAGE EACH PART WAS MEASURED WITH THE DIGITAL TESTER DURING PLAYBACK.

**ATTENTION** LES PIÈCES RÉPARÉES PAR UN ÉTANT DANGEREUSES AN POINT DE VUE SECURITE N'UTILISER QUE CELLES DECRITES DANS LA NOMENCLATURE DES PIÈCES.

**CAUTION** SINCE THESE PARTS MARKED BY ARE CRITICAL FOR SAFETY, USE ONES DESCRIBED IN PARTS LIST ONLY.

CAUTION: DIGITAL TRANSISTOR

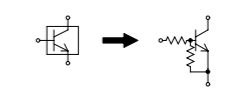

PCBD20  
CME066

# MICON /TUNER SCHEMATIC DIAGRAM

(AV PCB)

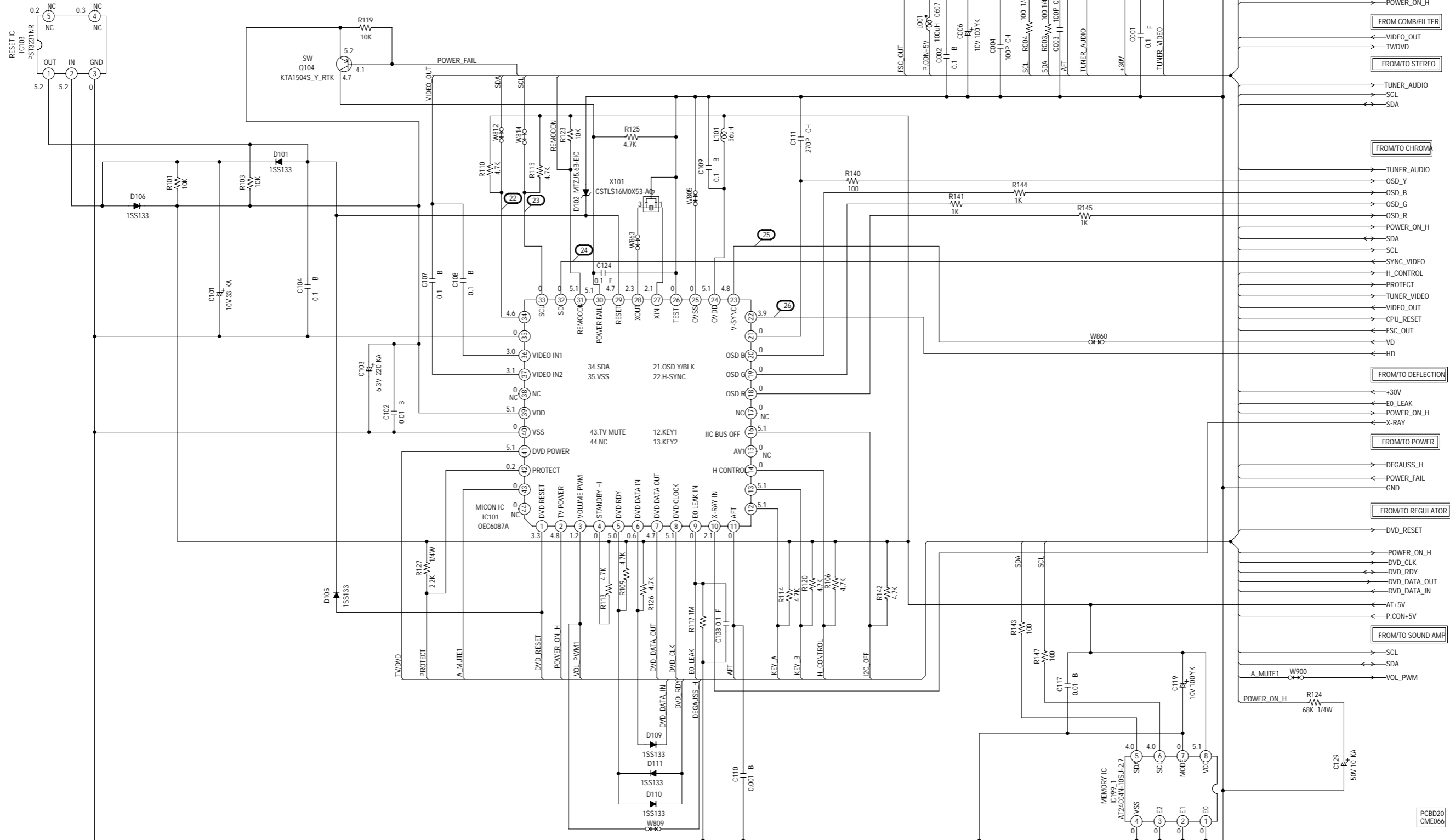

NOTE: THIS SCHEMATIC DIAGRAM IS THE LATEST AT THE TIME OF PRINTING AND SUBJECT TO CHANGE WITHOUT NOTICE.

NOTE: THE DC VOLTAGE AT EACH PART WAS MEASURED WITH THE DIGITAL TESTER WHEN THE COLOR BROADCAST WAS RECEIVED IN GOOD CONDITION AND PICTURE IS NORMAL.

ATTENTION: LES PIÈCES RÉPARÉES PAR UN ÉTANT DANGEREUSES AN POINT DE VUE SECURITE N'UTILISER QUE CELLS DECRITES DANS LA NOMENCLATURE DES PIÈCES.

CAUTION: SINCE THESE PARTS MARKED BY ARE CRITICAL FOR SAFETY, USE ONES DESCRIBED IN PARTS LIST ONLY.

PCBD20 CME066



# IN/OUT SCHEMATIC DIAGRAM (AV PCB)

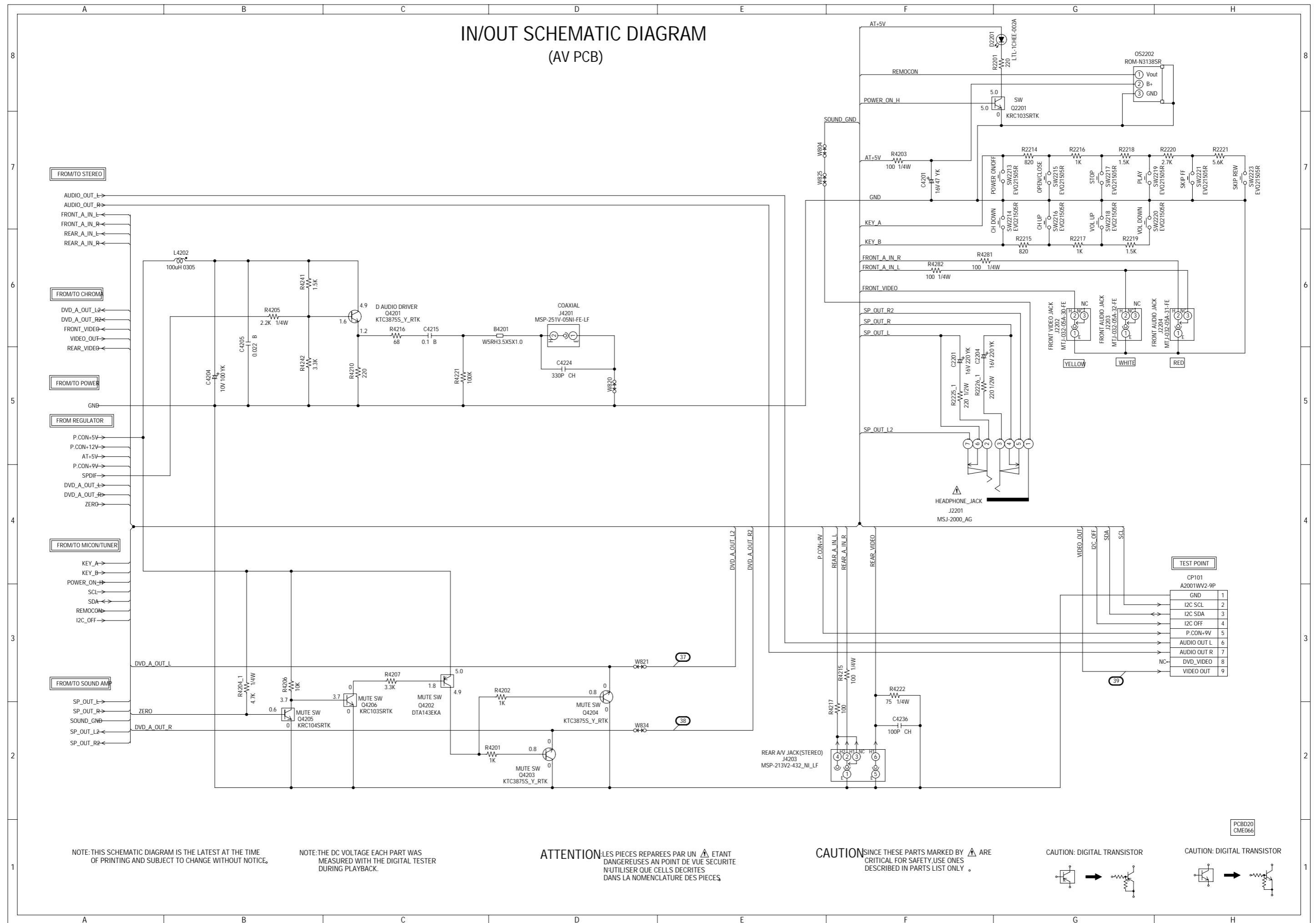

NOTE: THIS SCHEMATIC DIAGRAM IS THE LATEST AT THE TIME OF PRINTING AND SUBJECT TO CHANGE WITHOUT NOTICE.

NOTE: THE DC VOLTAGE EACH PART WAS MEASURED WITH THE DIGITAL TESTER DURING PLAYBACK.

**ATTENTION** LES PIÈCES RÉPARÉES PAR UN ÉTANT DANGEREUSES AU POINT DE VUE SÉCURITÉ N'UTILISER QUE CELLES DÉCRITES DANS LA NOMENCLATURE DES PIÈCES

**CAUTION** SINCE THESE PARTS MARKED BY ARE CRITICAL FOR SAFETY, USE ONES DESCRIBED IN PARTS LIST ONLY.

CAUTION: DIGITAL TRANSISTOR

CAUTION: DIGITAL TRANSISTOR

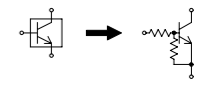
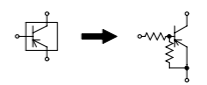

# DEFLECTION SCHEMATIC DIAGRAM (AV PCB)

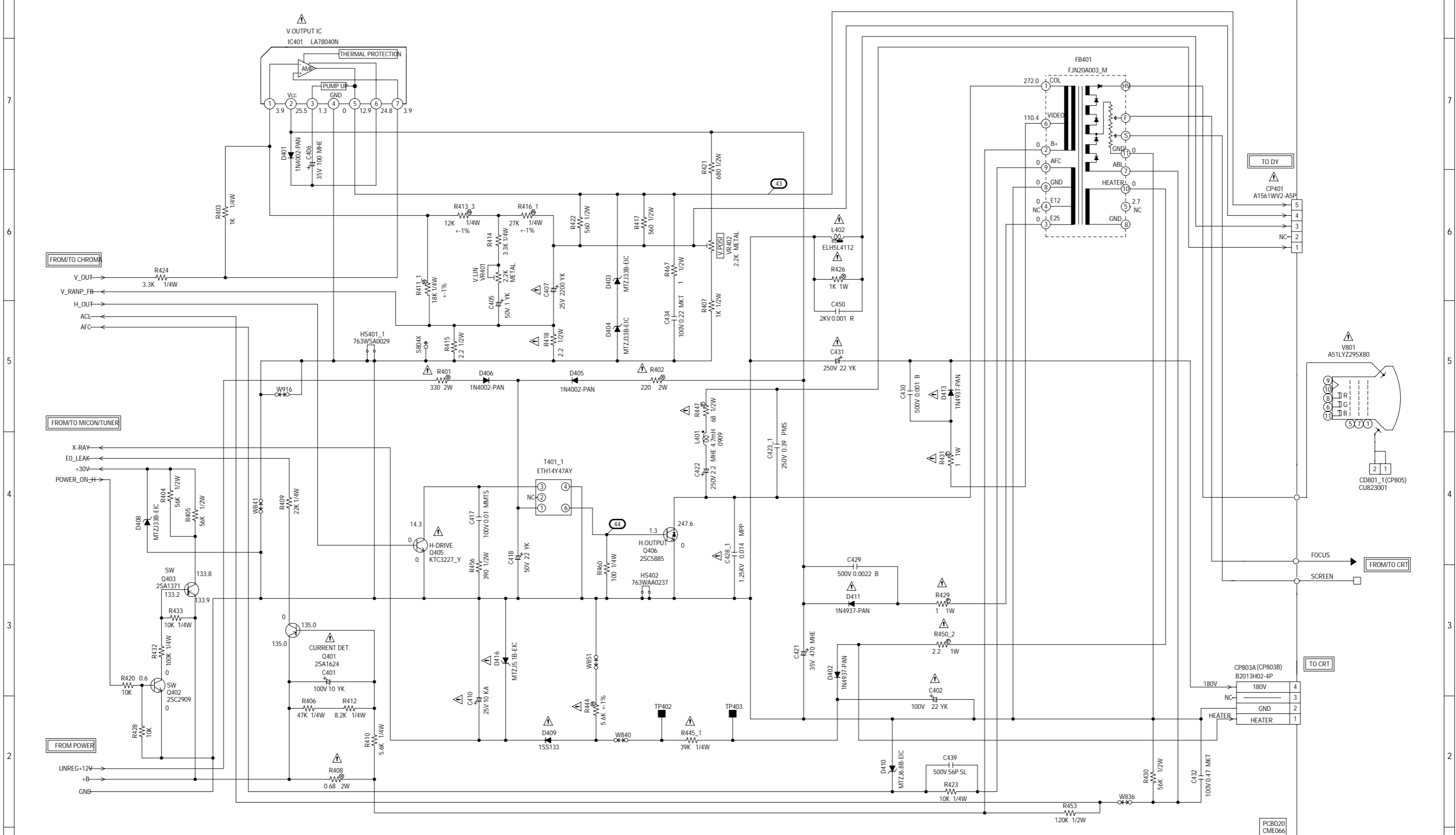

NOTE: THIS SCHEMATIC DIAGRAM IS THE LATEST AT THE TIME OF PRINTING AND SUBJECT TO CHANGE WITHOUT NOTICE.

NOTE: THE DC VOLTAGE AT EACH PART WAS MEASURED WITH THE DIGITAL TESTER WHEN THE COLOR BROADCAST WAS RECEIVED IN GOOD CONDITION AND PICTURE IS NORMAL.

NOTE: THE RESISTOR MARKED F IS FUSE RESISTOR. THE ALUMI ELECTROLYTIC CAPACITOR MARKED NP IS NON POLAR ONE.

ATTENTION: LES PIÈCES RÉPARÉES PAR UN ÉTANT DANGEREUSES AN POINT DE VUE SECURITE N'UTILISER QUE CELLS DÉCRITES DANS LA NOMENCLATURE DES PIÈCES.

CAUTION: SINCE THESE PARTS MARKED BY ARE CRITICAL FOR SAFETY, USE ONES DESCRIBED IN PARTS LIST ONLY.

# CRT SCHEMATIC DIAGRAM (CRT PCB)

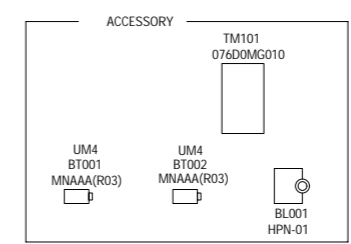
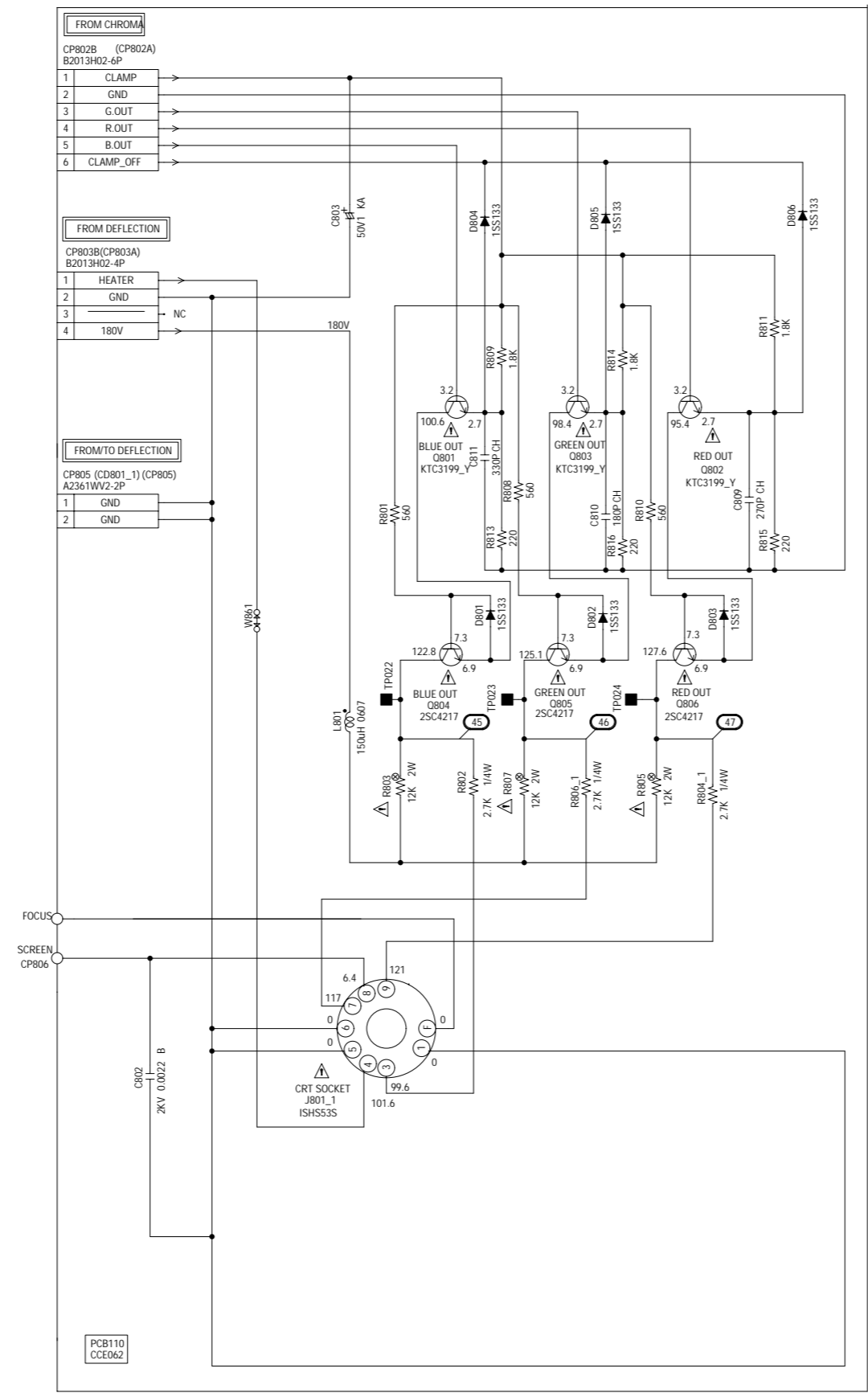

NOTE: THIS SCHEMATIC DIAGRAM IS THE LATEST AT THE TIME OF PRINTING AND SUBJECT TO CHANGE WITHOUT NOTICE.

NOTE: THE DC VOLTAGE AT EACH PART WAS MEASURED WITH THE DIGITAL TESTER WHEN THE COLOR BROADCAST WAS RECEIVED IN GOOD CONDITION AND PICTURE IS NORMAL.

**ATTENTION** - LES PIECES REPARÉES PAR UN ETANT DANGEREUSES AN POINT DE VUE SECURITE N'UTILISER QUE CELLS DECRITES DANS LA NOMENCLATURE DES PIECES

**CAUTION** - SINCE THESE PARTS MARKED BY ARE CRITICAL FOR SAFETY, USE ONES DESCRIBED IN PARTS LIST ONLY.

# POWER SCHEMATIC DIAGRAM (AV PCB)

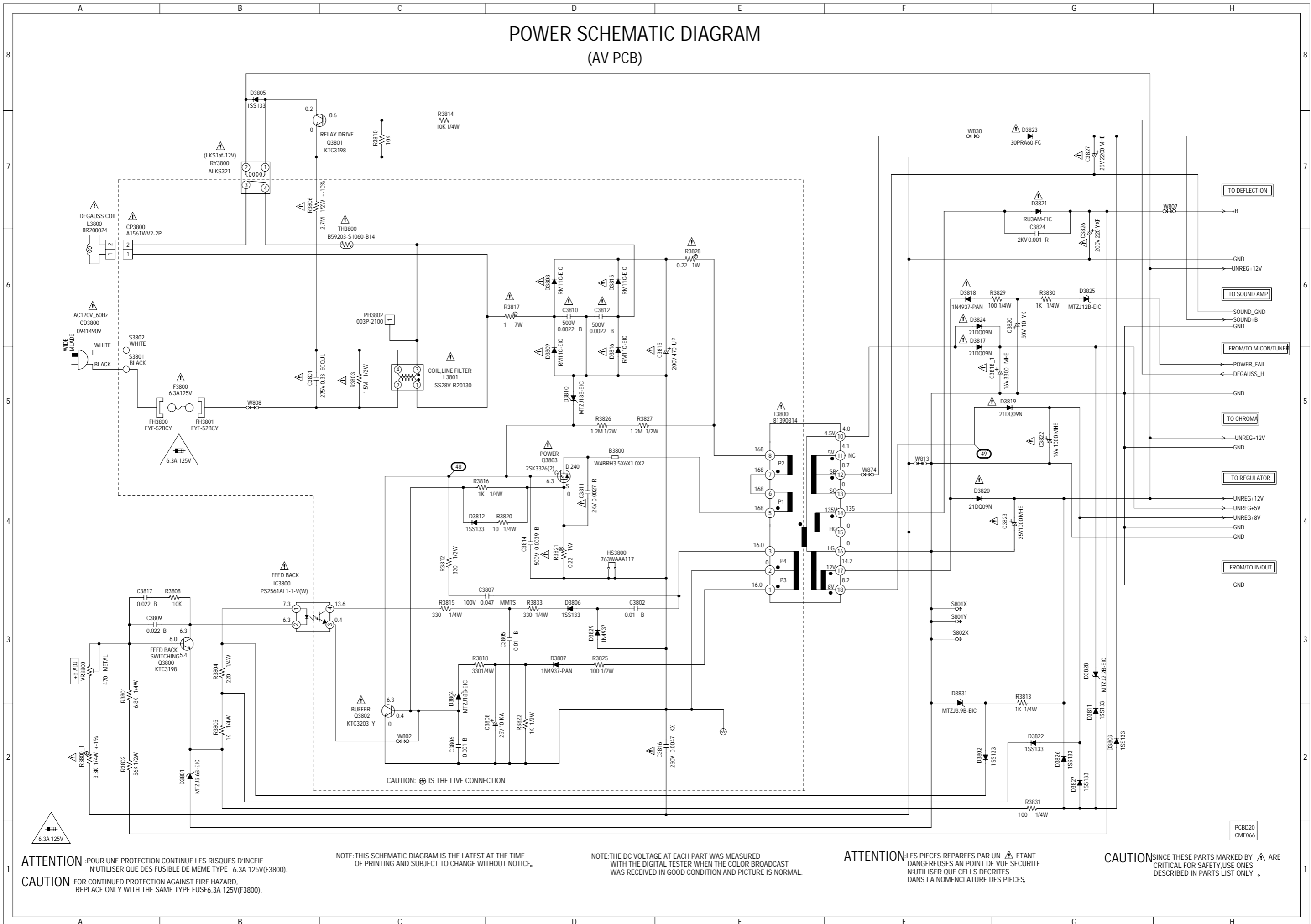

**ATTENTION** :POUR UNE PROTECTION CONTINUE LES RISQUES D'INCENDIE N'UTILISER QUE DES FUSIBLE DE MEME TYPE 6.3A 125V(F3800).  
**CAUTION** :FOR CONTINUED PROTECTION AGAINST FIRE HAZARD, REPLACE ONLY WITH THE SAME TYPE FUSE 6.3A 125V(F3800).

NOTE: THIS SCHEMATIC DIAGRAM IS THE LATEST AT THE TIME OF PRINTING AND SUBJECT TO CHANGE WITHOUT NOTICE.

NOTE: THE DC VOLTAGE AT EACH PART WAS MEASURED WITH THE DIGITAL TESTER WHEN THE COLOR BROADCAST WAS RECEIVED IN GOOD CONDITION AND PICTURE IS NORMAL.

**ATTENTION** LES PIECES REPARÉES PAR UN ÉTANT DANGEREUSES AN POINT DE VUE SECURITE N'UTILISER QUE CELLES DECRITES DANS LA NOMENCLATURE DES PIECES.

**CAUTION** SINCE THESE PARTS MARKED BY ARE CRITICAL FOR SAFETY, USE ONES DESCRIBED IN PARTS LIST ONLY.

# CHROMA SCHEMATIC DIAGRAM (AV PCB)

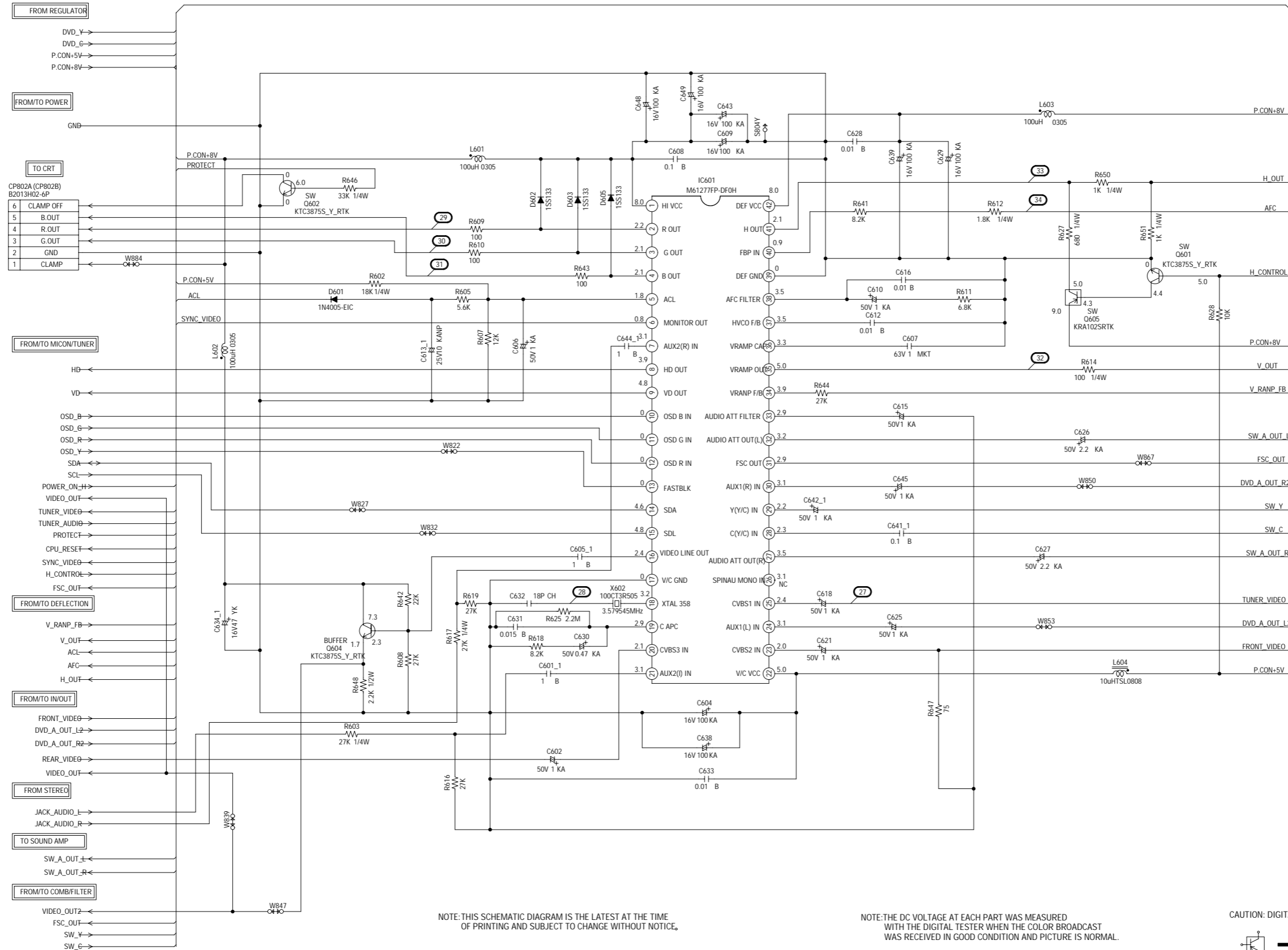

NOTE: THIS SCHEMATIC DIAGRAM IS THE LATEST AT THE TIME OF PRINTING AND SUBJECT TO CHANGE WITHOUT NOTICE.

NOTE: THE DC VOLTAGE AT EACH PART WAS MEASURED WITH THE DIGITAL TESTER WHEN THE COLOR BROADCAST WAS RECEIVED IN GOOD CONDITION AND PICTURE IS NORMAL.

CAUTION: DIGITAL TRANSISTOR

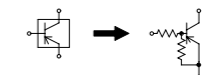

# COMB/FILTER SCHEMATIC DIAGRAM (MAIN PCB)

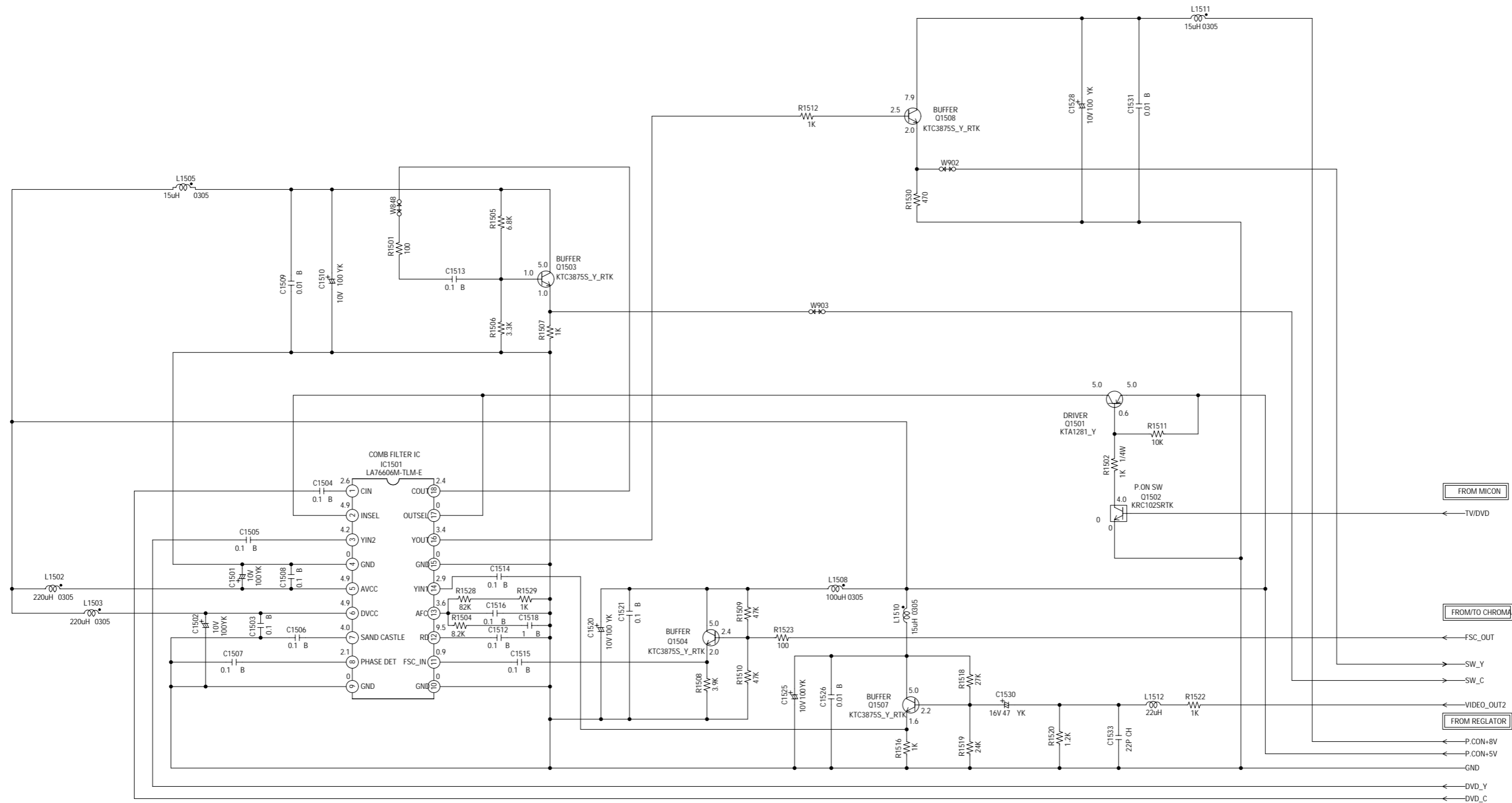

NOTE: THIS SCHEMATIC DIAGRAM IS THE LATEST AT THE TIME OF PRINTING AND SUBJECT TO CHANGE WITHOUT NOTICE.

NOTE: THE DC VOLTAGE AT EACH PART WAS MEASURED WITH THE DIGITAL TESTER WHEN THE COLOR BROADCAST WAS RECEIVED IN GOOD CONDITION AND PICTURE IS NORMAL.

CAUTION: DIGITAL TRANSISTOR

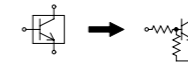

PCBD20  
CME066

# STEREO SCHEMATIC DIAGRAM (AV PCB)

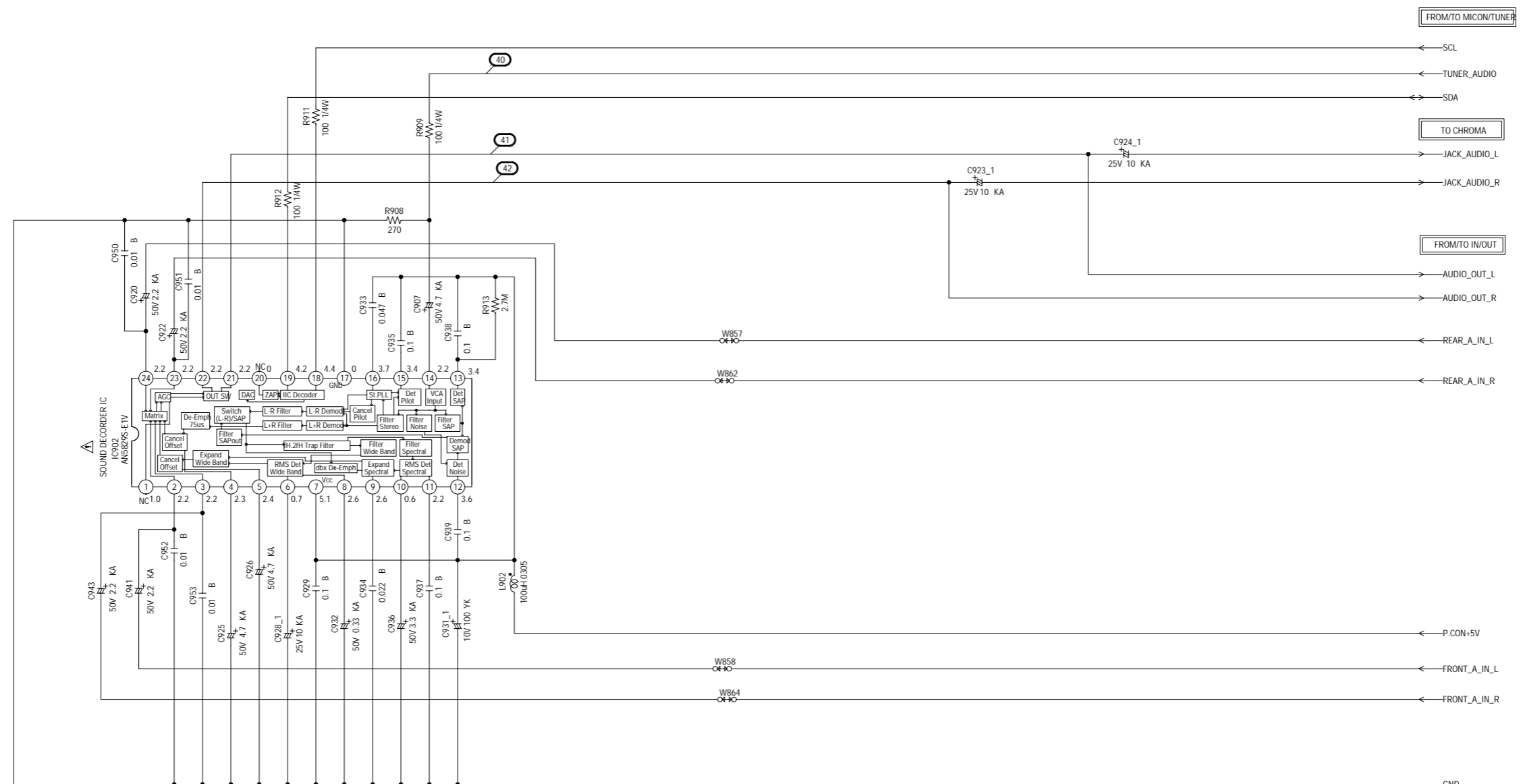

NOTE: THIS SCHEMATIC DIAGRAM IS THE LATEST AT THE TIME OF PRINTING AND SUBJECT TO CHANGE WITHOUT NOTICE.

NOTE: THE DC VOLTAGE AT EACH PART WAS MEASURED WITH THE DIGITAL TESTER WHEN THE COLOR BROADCAST WAS RECEIVED IN GOOD CONDITION AND PICTURE IS NORMAL.

**ATTENTION** LES PIÈCES RÉPARÉES PAR UN ÉTANT DANGEREUSES AN POINT DE VUE SECURITE N'UTILISER QUE CELLS DECRITES DANS LA NOMENCLATURE DES PIÈCES

**CAUTION** SINCE THESE PARTS MARKED BY ARE CRITICAL FOR SAFETY, USE ONES DESCRIBED IN PARTS LIST ONLY.

PCBD20  
CME066

# LOADING MOTOR/SW SCHEMATIC DIAGRAM

(SW PCB)

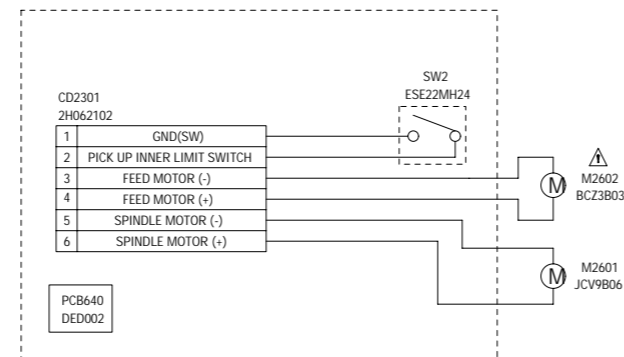

(LOADING MOTOR PCB)

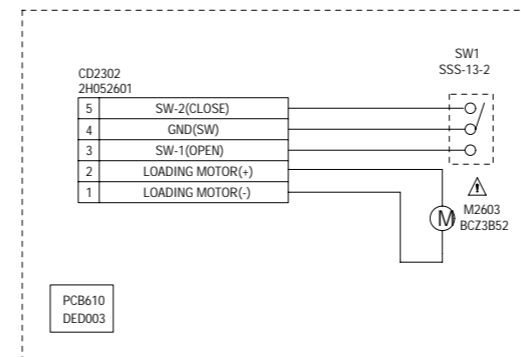

**ATTENTION** LES PIÈCES RÉPARÉES PAR UN  ÉTANT DANGEREUSES AN POINT DE VUE SECURITE N'UTILISER QUE CELLS DECRITES DANS LA NOMENCLATURE DES PIÈCES.

**CAUTION** SINCE THESE PARTS MARKED BY  ARE CRITICAL FOR SAFETY, USE ONES DESCRIBED IN PARTS LIST ONLY.

NOTE: THIS SCHEMATIC DIAGRAM IS THE LATEST AT THE TIME OF PRINTING AND SUBJECT TO CHANGE WITHOUT NOTICE.



# WAVEFORMS

## MPEG/MICON/DSP

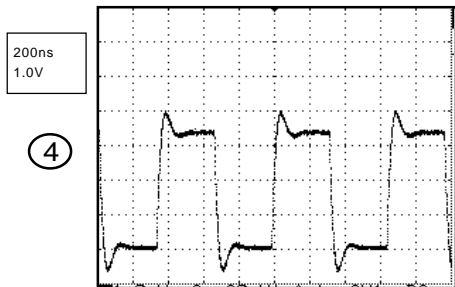
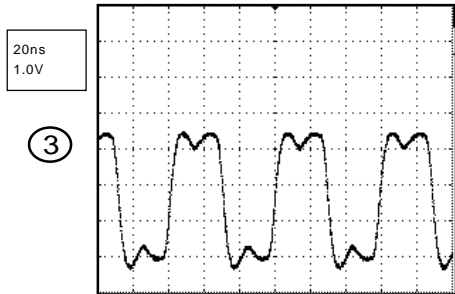
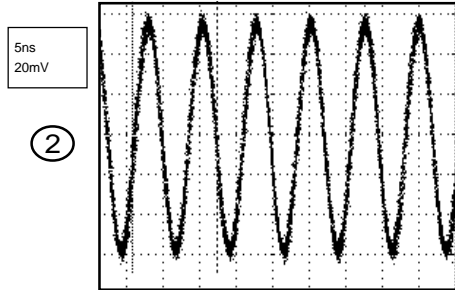
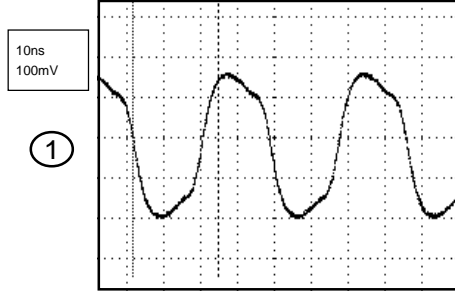

## MEMORY

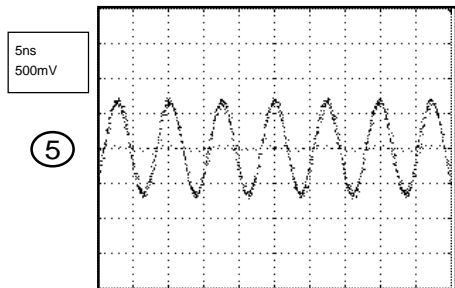

## AUDIO/VIDEO

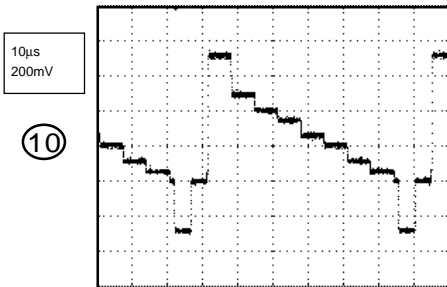
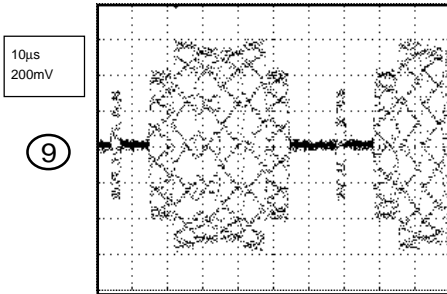
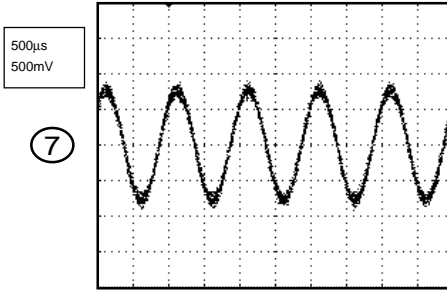
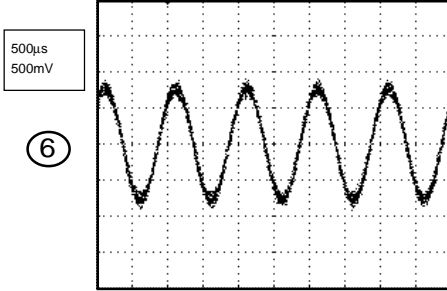

## MICON/TUNER

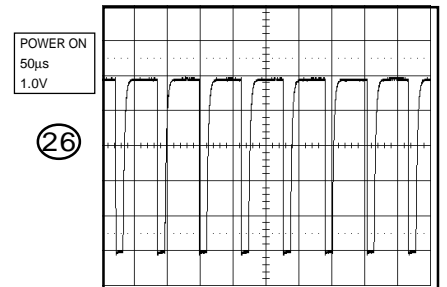
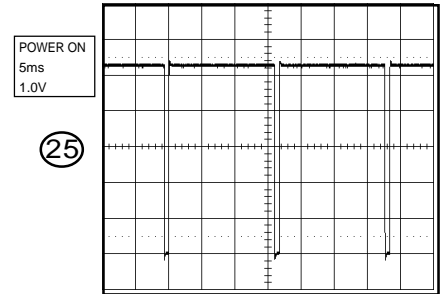
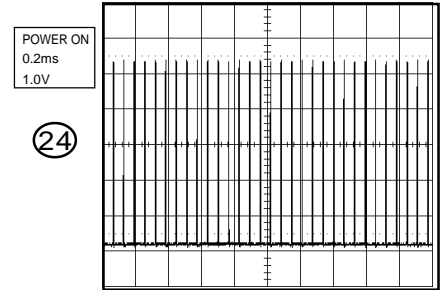
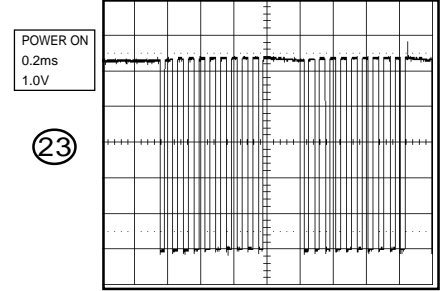
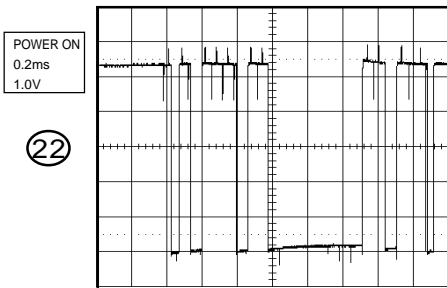

## CHROMA

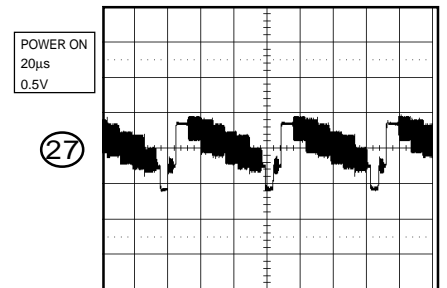

**NOTE:** The following waveforms were measured at the point of the corresponding balloon number in the schematic diagram.

# WAVEFORMS

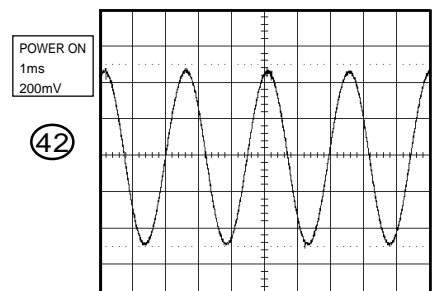
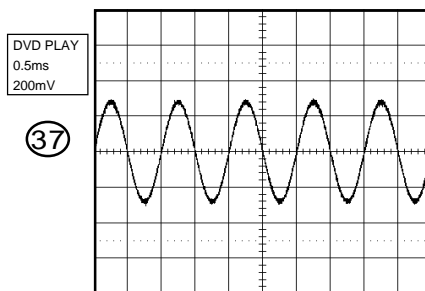
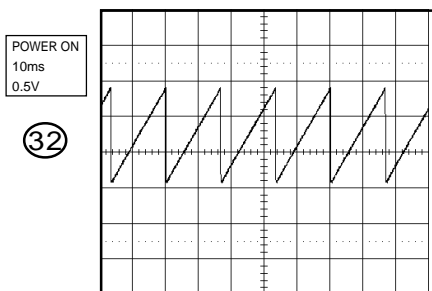
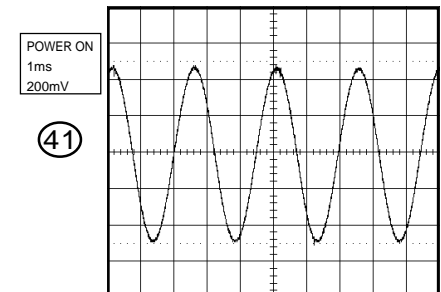
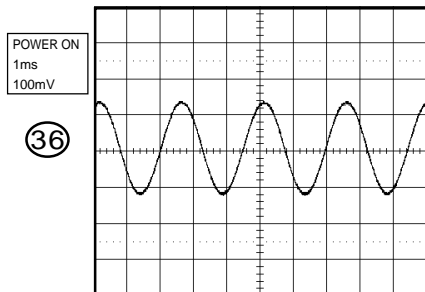
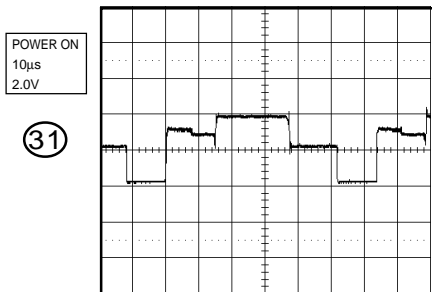
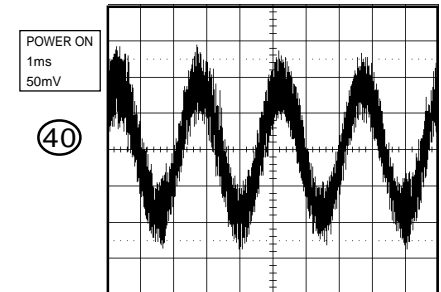
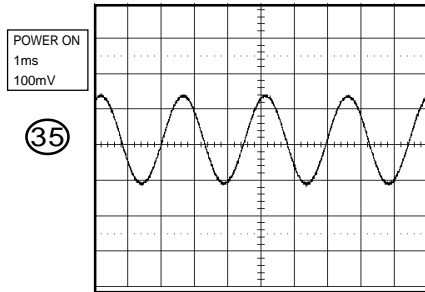
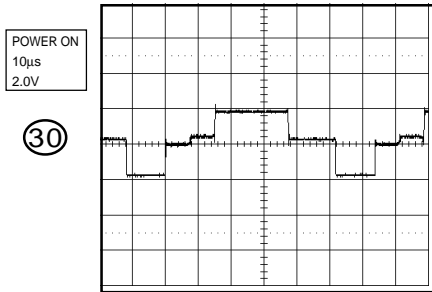
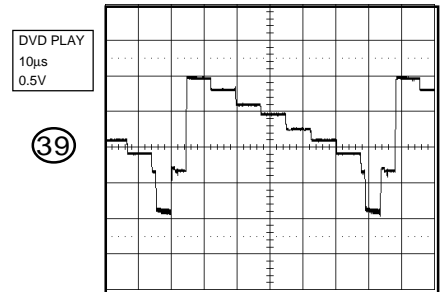
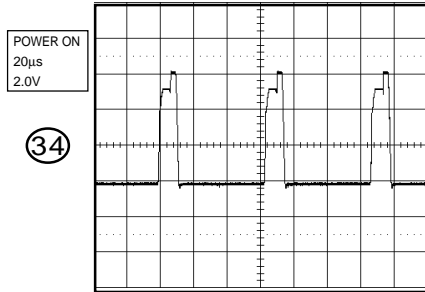
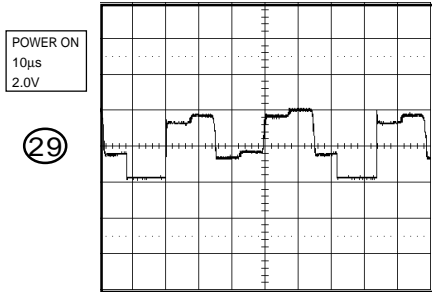
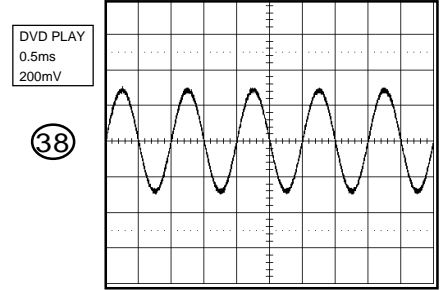
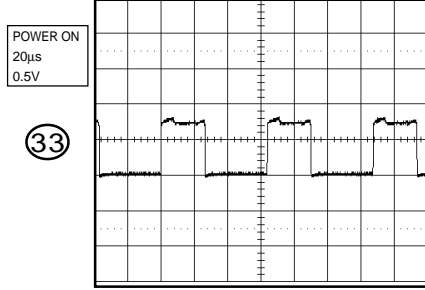
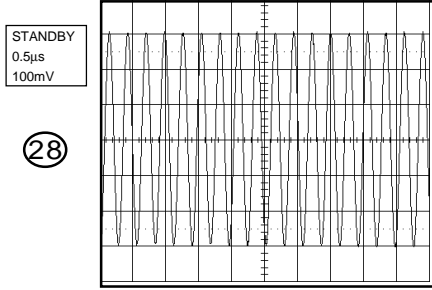

## SOUND AMP

## STEREO

## IN/OUT

**NOTE:** The following waveforms were measured at the point of the corresponding balloon number in the schematic diagram.

# WAVEFORMS

## DEFLECTION

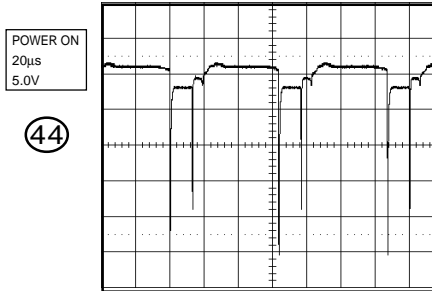
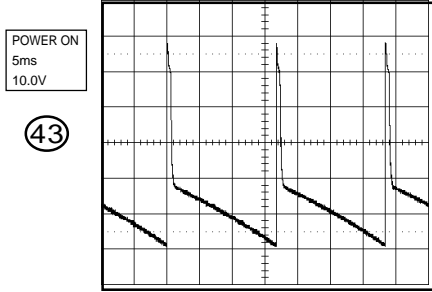

## CRT

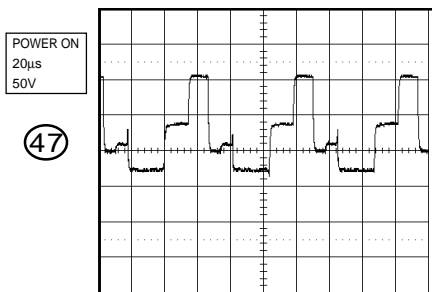
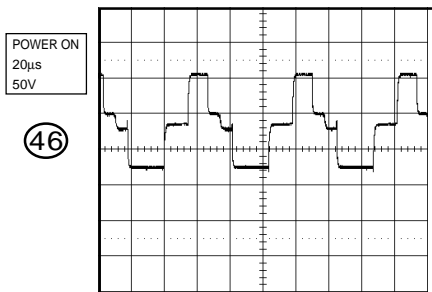
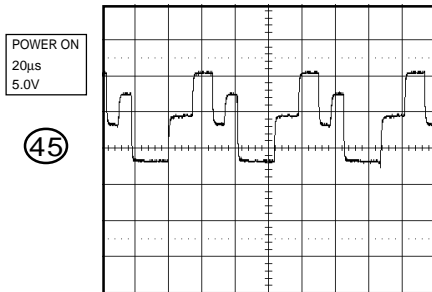

## POWER

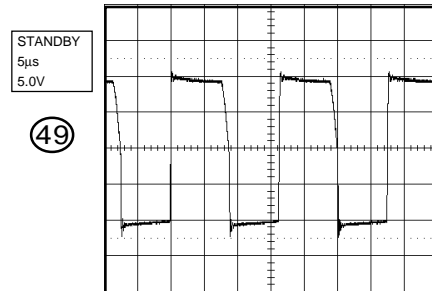

## SOUND AMP

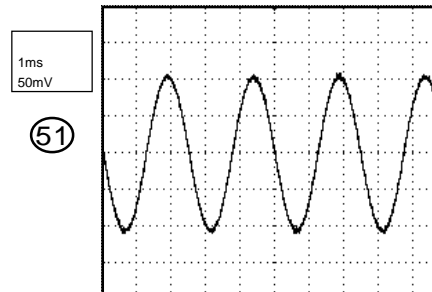
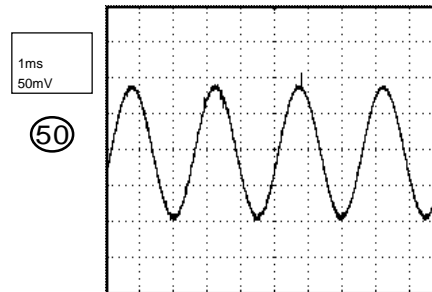

**NOTE:** The following waveforms were measured at the point of the corresponding balloon number in the schematic diagram.



# MECHANICAL EXPLODED VIEW

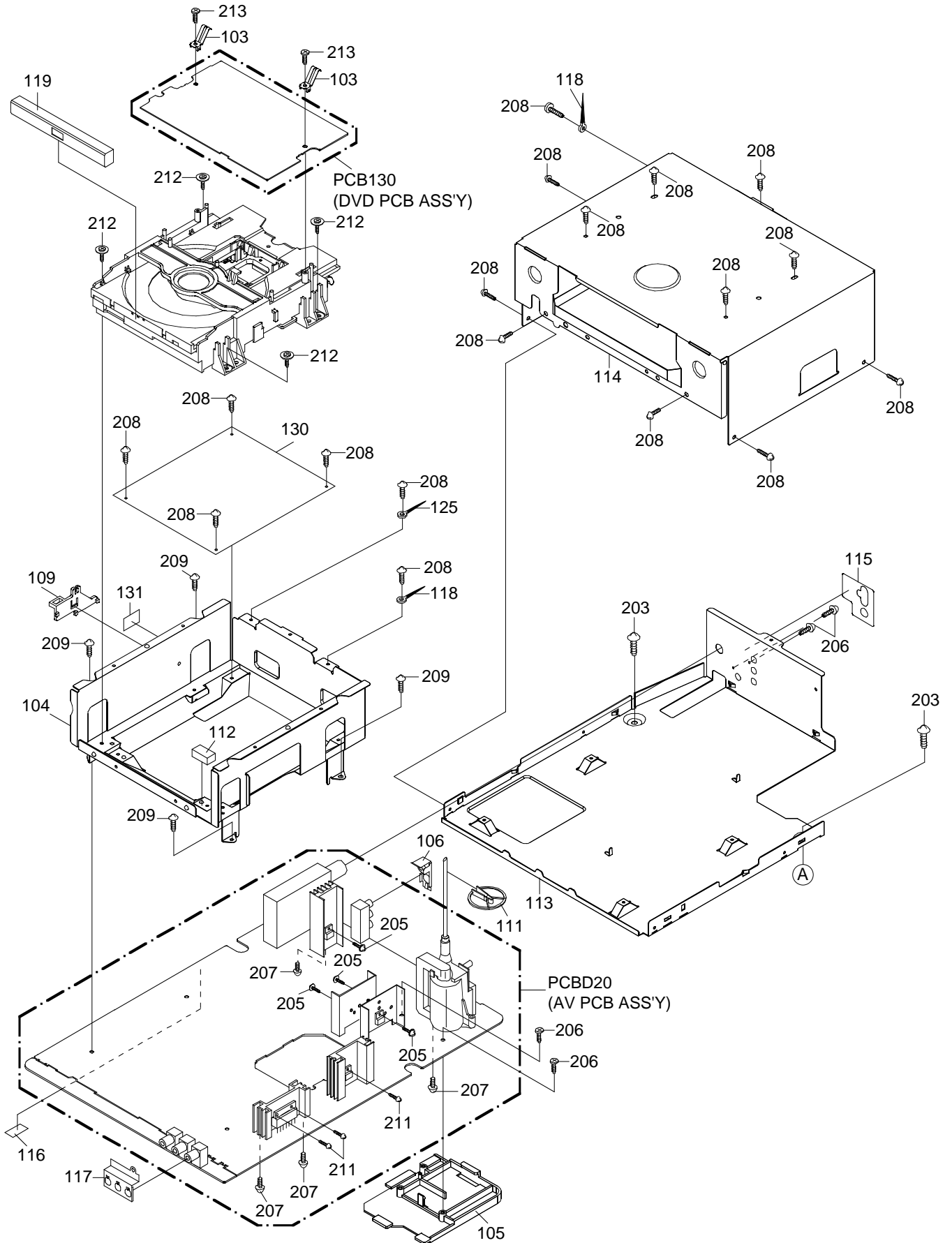

# MECHANICAL EXPLODED VIEW (PACKING DIAGRAM)

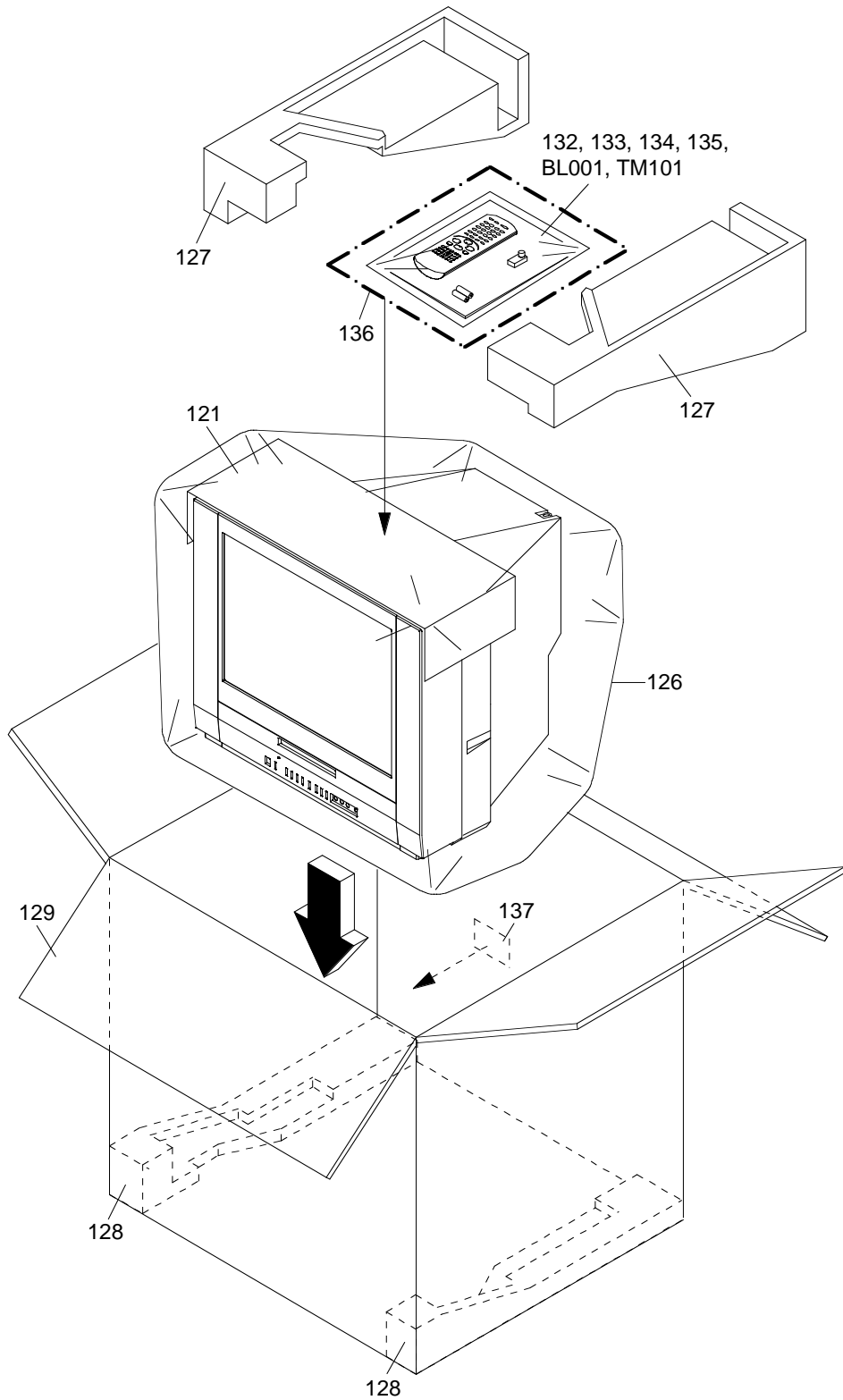

# DVD DECK EXPLODED VIEW

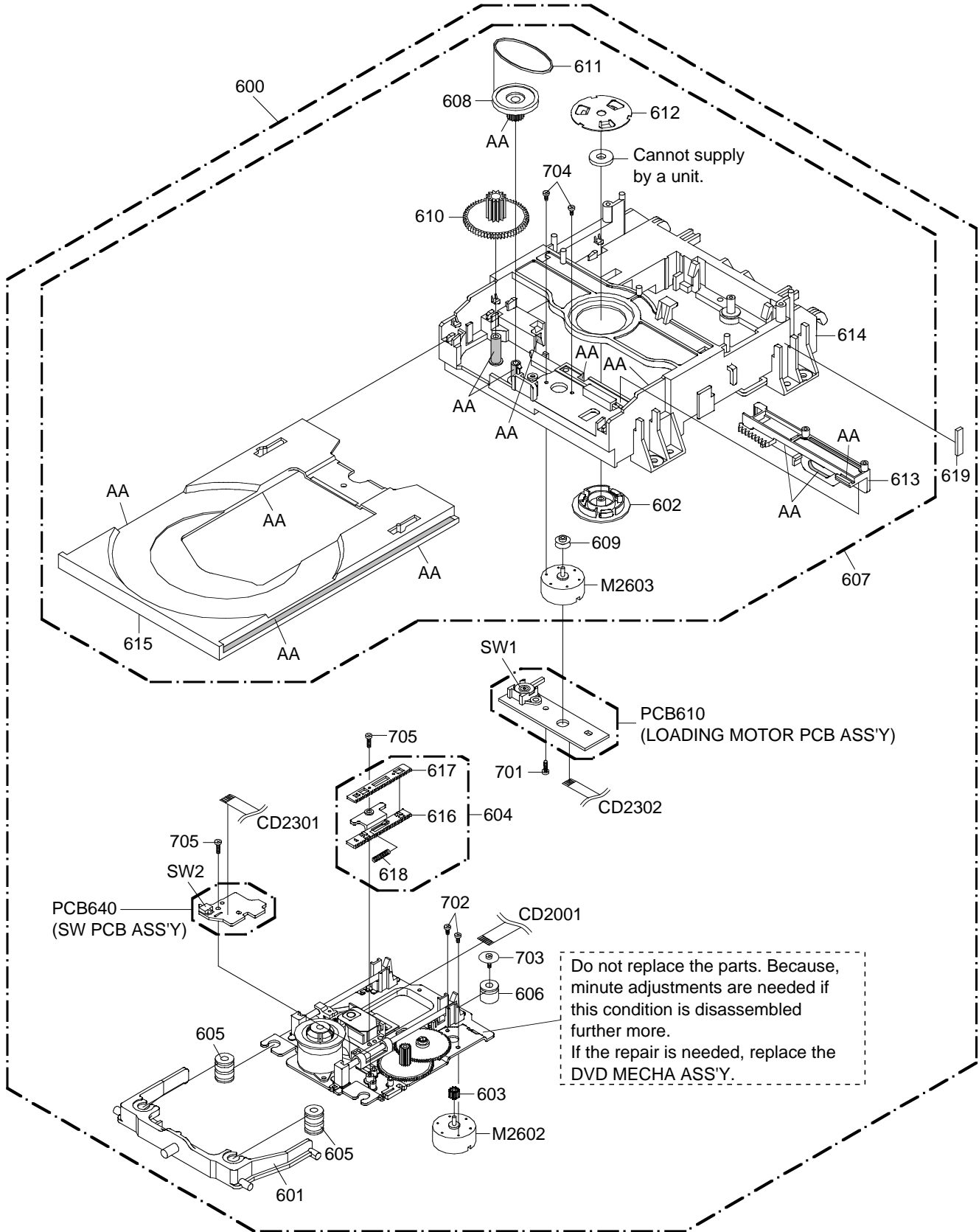

CLASS	MARK
GREASE	AA

**NOTE:** Applying positions AA for the grease are displayed for this section. Check if the correct grease is applied for each position.

# MECHANICAL REPLACEMENT PARTS LIST

Location No.	TSB P/N	Reference No.	Description
101	72783234	7A701A598A	FRONT CABI ASS'Y
101A	72783227	701WPJD185	CABINET FRONT
101B	72783264	711WPAA132	PLATE FRONT
101C	72783265	713WPAA232	GLASS LED
101D	72783230	713WPAA231	GUIDE REMOCON
101E	72783192	723549A054	BADGE BRAND
101F	72783232	735WPAA987	STOPPER BUTTON
101G	72783233	735WPBB480	BUTTON FRAME
101H	72796103	800WQ0A052	FELT SHEET
102	72783261	7A702A202A	BACK CABI ASS'Y
102A	72783228	702WPAA956	CABINET BACK
102B	72796302	800WQ0A109	FELT SHEET
102C	72796300	800WQ0A108	FELT SHEET
103	72798655	753WUA0069	SPRING EARTH
104	72799936	761WSA0155	ANGLE DECK
105	72798668	761WPA0249	HOLDER FBT
106	72795676	752WSA0290	SHIELD COMPO
107	72796254	761WPAA115	HOLDER SPEAKER
108	72794733	801WR00001	DAMPER SPEAKER
109	72798688	774WPA0006	HOLDER WIRE
110	72798684	762WPA0011	HOLDER CRT WIRE
111	72794734	899HV3T000	HOLDER ANODE WIRE
112	72781978	8965TS1017	CUSHION 65TS10-10(17.5*20*14)
113	72799383	702WSAA127	PLATE BOTTOM
114	72799373	702WSA0213	SHIELD TOP
115	72798551	7230007603	SHEET JACK
116	72799698	724WNAA008	SHEET PC
117	72798640	752WSA0333	SHIELD JACK
118	72795680	8995034000	CORD CLIP UL CO.
119	72783229	712WPJC209	PLATE TRAY-FRONT
120	72783231	722549A563	SHEET RATING
121	72795703	791WHAA134	LIGHTRON SHEET
122	72783235	800WR0A010	SHEET CRT SUPPORT (D)
123	72783263	726000A129	SHEET CRT SERVICEMAN
124	72795687	741WUA0021	SPRING EARTH
125	72795699	899EFBA002	WIRING-CLIP
126	72795702	791WHAA114	FILM BAG
127	72796268	792WHA0422	PACKAGE TOP
128	72796269	792WHA0423	PACKAGE BOTTOM
129	72783259	793WCDD056	GIFT BOX
130	72799853	752WSA0488	SHIELD DECK
131	72783197	753WEA0033	SHEET CU
132	72781569	J3N51617A	REGISTRATION CARD
133	72781605	J5S10229A	INFORMATION SHEET(USA)
134	72781635	JB5ND300	POLYBAG INSTRUCTION(REDCAUTION)
135	72783260	J5W20101A	INSTRUCTION BOOK
136	72783257	A5W201Y975	INSTRUCTION BOOK KIT
137	72783258	723000D242	SHEET BAR CODE
201	72781287	8141J50C5U	SCREW TAP TITE(P) GW22 5*35 CH HEXAGON
202	72781279	8117540A6U	SCREW TAP TITE(B0) TRUSS 4*16 CH
203	72798794	811754080U	SCREW TAP TITE(B0) TRUSS 4*8 CH
204	72781295	8162540A6U	SCREW TAPPING (B0) WASHER 18
205	72781255	810913080U	SCREW TAP TITE(B) WH7 3*8 CH
206	72798787	810923080U	SCREW TAP TITE(B) BIND 3*8 CH
207	72781251	810963080Q	SCREW TAP TITE(B) BRAZIER 3*8 STAINLESS
208	72781247	810923060U	SCREW TAP TITE(B) BIND 3*6 CH
209	72781248	810923070U	SCREW TAP TITE(B) R BIND 3*7 CH
210	72798791	8110630A0U	SCREW TAP TITE(P) BRAZIER 3*10 CH
211	72798786	810763080U	SCREW TAP TITE(S) BRAZIER 3*8 CH
212	72781263	810F13080U	SEMS(F) 3*8 CH
213	72795782	811022680U	SCREW TAP TITE(P) BIND 2.6*8 CH
214	72798790	811063080U	SCREW TAP TITE(P) BRAZIER 3*8 CH

# DVD DECK REPLACEMENT PARTS LIST

Location No.	TSB P/N	Reference No.	Description
△600	72783471	A5N930I650	DVD MECHA ASS'Y A5N930I650
601	72795767	92P100109A	HOLDER, TRAVERSE
602	72795768	92P100094A	CLAMPER
603	72795769	92P100088A	GEAR, MOTOR
604	72798813	92AAA0013A	FEED RACK ASS'Y
605	72795771	92P200013A	INSULATOR(F)
606	72795772	92P200014A	INSULATOR(R)
607	72795773	92SBB0030A	LOADER SUB ASS'Y
608	72795774	92P100095A	GEAR, PULLEY
609	72795775	92P100097A	PULLEY, MOTOR
610	72795776	92P100096A	GEAR, MAIN
611	72795777	92P200012A	BELT, LOADING
612	72795778	92P000014A	PLATE, CLAMPER
613	72795779	92P100093A	RACK, LOADING
614	72795780	92P100091A	FRAME, MAIN
615	72795781	92P100100A	TRAY
616	72798836	92P100089A	RACK, FEED 1
617	72798837	92P100090A	RACK, FEED 2
618	72798849	92P300020A	SPRING, RACK FEED
619	72795888	800WFAA008	CUSHION C
701	72795782	811022680U	SCREW TAP TITE(P) BIND 2.6*8 CH
702	72795783	814011723U	SCREW, PAN M1.7*2.3 P3 CH
703	72795784	816112080U	SEMS. TAP TITE(P) PAN W10 2*8 CH
704	72795785	814011730U	SCREW, PAN M1.7*3 P3 CH
705	72796070	811022080U	SCREW, TAP TITE(P) BIND 2*8 CH
CD2001	72783183	122J401903	CORD JUMPER 127000-2928
CD2301	72795869	122H062102	CORD JUMPER 2H062102
CD2302	72795870	122H052601	CORD JUMPER 2H052601
△M2602	72795947	1515S98003	FEED MOTOR BCZ3B03B
△M2603	72795948	1596S18003	MOTOR, LOADING BCZ3B52B
PCB610	72783202	A5M4016610	PCB ASS'Y DED003A
PCB640	72783203	A5N813W640	PCB ASS'Y DED002B
SW1	72796050	0515S32002	SWITCH SSS-13-2
SW2	72796052	0500101037	PUSH SWITCH ESE22MH24

# ELECTRICAL REPLACEMENT PARTS LIST

Location No.	TSB P/N	Reference No.	Description	
<b>RESISTORS</b>				
R310	72797927	R3X28B3R3J	R,METAL OXIDE	3.3 OHM 3W
▲R401	72781694	R3K58A331J	R,METAL OXIDE	330 OHM 2W
▲R402	72781693	R3K58A221J	R,METAL OXIDE	220 OHM 2W
R408	72796440	R3X28AR68J	R,METAL OXIDE	0.68 OHM 2W
▲R418	72794597	R002T22R2J	RC	2.2 OHM 1/2W
R426	72796031	R3K181102J	R,METAL OXIDE	1K OHM 1W
▲R429	72795519	R65581010J	R,FUSE	1 OHM 1W
▲R431	72795519	R65581010J	R,FUSE	1 OHM 1W
▲R444	72795514	R4X5T6562F	R,METAL	5.6K OHM 1/6W
▲R445	72796042	R002T4393J	RC	39K OHM 1/4W
▲R447	72781748	R638U2680J	R,FUSE	68 OHM 1/2W
▲R450	72796023	R638812R2J	R,FUSE	2.2 OHM 1W
▲R803	72794659	R3X18A123J	R,METAL OXIDE	12K OHM 2W
▲R805	72794659	R3X18A123J	R,METAL OXIDE	12K OHM 2W
▲R807	72794659	R3X18A123J	R,METAL OXIDE	12K OHM 2W
R3005	72797918	R3X28B1R8J	R,METAL OXIDE	1.8 OHM 3W
▲R3800	72781721	R4K1T4332F	R,METAL	3.3K OHM 1/4W
▲R3803	72795500	R002T2155J	RC	1.5M OHM 1/2W
▲R3806	72794631	ROG3K2275K	RC	2.7M OHM 1/2W
▲R3812	72795109	R002T2331J	RC	330 OHM 1/2W
R3817	72797976	R5X2CE010J	R,CEMENT	1 OHM 7W
▲R3821	72797865	R3X181R22J	R,METAL OXIDE	0.22 OHM 1W
▲R3828	72794633	R63881R22J	R,FUSE	0.22 OHM 1W
▲R3829	72794684	R002T4101J	RC	100 OHM 1/4W
<b>CAPACITORS</b>				
▲C357	72795574	E02LF3222M	CE	2200 UF 25V
▲C402	72794396	E02LU8220M	CE	22 UF 100V
▲C407	72795574	E02LF3222M	CE	2200 UF 25V
▲C421	72797489	E5EZT4471M	CE	470 UF 35V
C423	72794389	P4J7F3394J	CMPP	0.39 UF 250V PMS
▲C428	72783470	P4N8FJ143H	CMPP	0.014 UF 1.25KV
▲C431	72795570	E0ELFD220M	CE	22 UF 250V
C450	72794399	C0PLRR713K	CC	0.001 UF 2KV R
C802	72794440	C0JBB07H3K	CC	0.0022UF 2KV B
C3002	72797374	E02LF1222M	CE	2200 UF 10V
C3010	72797374	E02LF1222M	CE	2200 UF 10V
C3011	72797374	E02LF1222M	CE	2200 UF 10V
▲C3801	72794401	P2122B334M	CMP	0.33 UF 275V ECQUL
C3810	72795068	C0J0B05H3K	CC	0.0022UF 500V B
C3811	72797086	C03L0R7K3K	CC	0.0027UF 2KV R
C3812	72795068	C0J0B05H3K	CC	0.0022UF 500V B
▲C3815	72795573	E51CGC471M	CE	470 UF 200V
▲C3816	72795579	CD39E0MQ3M	CC	0.0047UF 250V
▲C3818	72797478	E5EZF2332M	CE	3300 UF 16V
▲C3820	72797413	E02LU54R7M	CE	4.7 UF 50V
▲C3822	72797483	E5EZT2102M	CE	1000 UF 16V
▲C3823	72794381	E5EZF3222M	CE	2200 UF 25V
C3824	72794393	C03L0R713K	CC	0.001 UF 2KV R
▲C3826	72794411	E62NFC221M	CE	220 UF 200V
▲C3827	72794381	E5EZF3222M	CE	2200 UF 25V
<b>DIODES</b>				
D101	72794491	D1VT001330	DIODE,SILICON	1SS133T-77
D102	72783214	D9WU05R62B	DIODE,ZENER	MTZJ5.6B-EIC
D105	72794491	D1VT001330	DIODE,SILICON	1SS133T-77
D106	72794491	D1VT001330	DIODE,SILICON	1SS133T-77
D109	72794491	D1VT001330	DIODE,SILICON	1SS133T-77
D110	72794491	D1VT001330	DIODE,SILICON	1SS133T-77
D111	72794491	D1VT001330	DIODE,SILICON	1SS133T-77
D301	72794491	D1VT001330	DIODE,SILICON	1SS133T-77
D401	72783209	D2MXN40020	DIODE,FAST RECOVERY	1N4002-PAN
▲D402	72795543	D2MXN49370	DIODE,FAST RECOVERY	1N4937-PAN
D403	72781366	D9WU03302B	DIODE,ZENER	MTZJ33B-EIC
D404	72781366	D9WU03302B	DIODE,ZENER	MTZJ33B-EIC
D405	72783209	D2MXN40020	DIODE,FAST RECOVERY	1N4002-PAN
D406	72783209	D2MXN40020	DIODE,FAST RECOVERY	1N4002-PAN
D408	72781366	D9WU03302B	DIODE,ZENER	MTZJ33B-EIC
▲D409	72794491	D1VT001330	DIODE,SILICON	1SS133T-77
D410	72781369	D9WU06R82B	DIODE,ZENER	MTZJ6.8B-EIC
▲D411	72795543	D2MXN49370	DIODE,FAST RECOVERY	1N4937-PAN
▲D413	72795543	D2MXN49370	DIODE,FAST RECOVERY	1N4937-PAN
▲D416	72781368	D9WU05R12B	DIODE,ZENER	MTZJ5.1B-EIC
D601	72795626	D2WXN40050	DIODE,SILICON	1N4005-EIC
D602	72794491	D1VT001330	DIODE,SILICON	1SS133T-77
D603	72794491	D1VT001330	DIODE,SILICON	1SS133T-77
D605	72794491	D1VT001330	DIODE,SILICON	1SS133T-77

# ELECTRICAL REPLACEMENT PARTS LIST

Location No.	TSB P/N	Reference No.	Description	
<b>DIODES</b>				
D801	72794491	D1VT001330	DIODE,SILICON	1SS133T-77
D802	72794491	D1VT001330	DIODE,SILICON	1SS133T-77
D803	72794491	D1VT001330	DIODE,SILICON	1SS133T-77
D804	72794491	D1VT001330	DIODE,SILICON	1SS133T-77
D805	72794491	D1VT001330	DIODE,SILICON	1SS133T-77
D806	72794491	D1VT001330	DIODE,SILICON	1SS133T-77
D2201	72796482	0021E2Q140	LED	LTL-1CHEE-002A
D2303	72795897	DD7R0S3550	DIODE,SILICON	1SS355 TE-17
D2304	72795897	DD7R0S3550	DIODE,SILICON	1SS355 TE-17
D3001	72783209	D2MXN40020	DIODE,FAST RECOVERY	1N4002-PAN
D3002	72783210	D9WU01002B	DIODE,ZENER	MTZJ10B-EIC
D3003	72783214	D9WU05R62B	DIODE,ZENER	MTZJ5.6B-EIC
D3004	72783209	D2MXN40020	DIODE,FAST RECOVERY	1N4002-PAN
D3005	72783209	D2MXN40020	DIODE,FAST RECOVERY	1N4002-PAN
D3006	72783209	D2MXN40020	DIODE,FAST RECOVERY	1N4002-PAN
D3801	72783214	D9WU05R62B	DIODE,ZENER	MTZJ5.6B-EIC
D3802	72794491	D1VT001330	DIODE,SILICON	1SS133T-77
D3803	72794491	D1VT001330	DIODE,SILICON	1SS133T-77
D3804	72783211	D9WU01802B	DIODE,ZENER	MTZJ18B-EIC
D3805	72794491	D1VT001330	DIODE,SILICON	1SS133T-77
D3806	72794491	D1VT001330	DIODE,SILICON	1SS133T-77
D3807	72795543	D2MXN49370	DIODE,FAST RECOVERY	1N4937-PAN
▲D3808	72794473	D2WTRM11C0	DIODE,SILICON	RM11C-EIC
▲D3809	72794473	D2WTRM11C0	DIODE,SILICON	RM11C-EIC
▲D3810	72783211	D9WU01802B	DIODE ZENER	MTZJ18B-EIC
D3811	72794491	D1VT001330	DIODE,SILICON	1SS133T-77
D3812	72794491	D1VT001330	DIODE,SILICON	1SS133T-77
▲D3815	72794473	D2WTRM11C0	DIODE,SILICON	RM11C-EIC
▲D3816	72794473	D2WTRM11C0	DIODE,SILICON	RM11C-EIC
▲D3817	72794480	D28T21DQN9	DIODE,SCHOTTKY	21DQ09N-TA2B1
▲D3818	72795543	D2MXN49370	DIODE,FAST RECOVERY	1N4937-PAN
▲D3819	72794480	D28T21DQN9	DIODE,SCHOTTKY	21DQ09N-TA2B1
▲D3820	72794480	D28T21DQN9	DIODE,SCHOTTKY	21DQ09N-TA2B1
▲D3821	72797312	D2WXRU3AM0	DIODE,SILICON	RU3AM-EIC
D3822	72794491	D1VT001330	DIODE,SILICON	1SS133T-77
▲D3823	72794474	D28FOPRA60	DIODE,RECTIFIER	30PRA60-FC
▲D3824	72794480	D28T21DQN9	DIODE,SCHOTTKY	21DQ09N-TA2B1
D3825	72781364	D9WU01202B	DIODE,ZENER	MTZJ12B-EIC
D3826	72794491	D1VT001330	DIODE,SILICON	1SS133T-77
D3827	72794491	D1VT001330	DIODE,SILICON	1SS133T-77
D3828	72783212	D9WU02R22B	DIODE,ZENER	MTZJ2.2B-EIC
D3829	72794483	D2WXN49370	DIODE,SILICON	1N4937
D3831	72783213	D9WU03R92B	DIODE,ZENER	MTZJ3.9B-EIC
D4002	72795897	DD7R0S3550	DIODE,SILICON	1SS355 TE-17
D4003	72795897	DD7R0S3550	DIODE,SILICON	1SS355 TE-17
D4004	72795897	DD7R0S3550	DIODE,SILICON	1SS355 TE-17
D4005	72795897	DD7R0S3550	DIODE,SILICON	1SS355 TE-17
D4006	72795897	DD7R0S3550	DIODE,SILICON	1SS355 TE-17
D4007	72795897	DD7R0S3550	DIODE,SILICON	1SS355 TE-17
D8111	72795897	DD7R0S3550	DIODE,SILICON	1SS355 TE-17
D8112	72795897	DD7R0S3550	DIODE,SILICON	1SS355 TE-17
<b>ICS</b>				
IC101	72783219	I55F06087A	IC	OEC6087A
IC103	72796084	I9UF032310	IC	PST3231NR
IC199	72783239	A5W301SD25	INIT DATA	AT24C04N-10SU-2.7
IC302	72794498	I01FF58910	IC	AN5891SA-E1V
IC351	72797560	I0FSP52760	IC	AN5276
▲IC401	72795534	I03TD804N0	IC	LA78040N-E
IC601	72783217	I06FC12770	IC	M61277FP-DF0H
IC902	72795535	I01FF58290	IC	AN5829S-E1V
IC1501	72783240	I03FE66060	IC	LA76606M-TLM-E
IC2301	72783216	I03FV65650	IC	LA6565VR-TLM-E
IC3001	72783218	I07F90WTP0	IC	BA00BCOWT-V5
IC3002	72795906	I1KA78R050	IC	KIA278R05PI
▲IC3800	72794512	000220002W	PHOTO COUPLER	PS2561AL1-1-V(W)
IC4001	72783220	ICQK068621	IC	ZR36862PQCG-B
IC4003	72795912	I07F9E00W0	IC	BA33E00WHFP-TR
IC4007	72783241	S5W301SF01	MEMORY DATA	SST39VF1601-70-4C-EKE
IC4009	72783221	IF9J0161A7	IC	M12L16161A-7TG
IC8102	72795922	I17F017530	IC	PCM1753DBQR
<b>TRANSISTORS</b>				
Q104	72794566	TAAA1504SY	TRANSISTOR,SILICON	KTA1504S_Y_RTK
Q301	72794566	TAAA1504SY	TRANSISTOR,SILICON	KTA1504S_Y_RTK
Q401	72794569	TA3T016240	TRANSISTOR,SILICON	2SA1624-AA
Q402	72795474	TC3T029090	TRANSISTOR,SILICON	2SC2909(S,T)-AA

# ELECTRICAL REPLACEMENT PARTS LIST

Location No.	TSB P/N	Reference No.	Description	
<b>TRANSISTORS</b>				
▲Q403	72795475	TA3T1371A0	TRANSISTOR,SILICON	2SA1371(D,E)-AE
▲Q405	72794561	TCAT03227Y	TRANSISTOR,SILICON	KTC3227_Y-AT
▲Q406	72782813	TC1G058850	TRANSISTOR,SILICON	2SC5885
Q601	72794571	TCAA3875SY	TRANSISTOR,SILICON	KTC3875S_Y_RTK
Q602	72794571	TCAA3875SY	TRANSISTOR,SILICON	KTC3875S_Y_RTK
Q604	72794571	TCAA3875SY	TRANSISTOR,SILICON	KTC3875S_Y_RTK
Q605	72795963	TPAAB05001	COMPOUND TRANSISTOR	KRA102SRTK
Q801	72794573	TCATC3199Y	TRANSISTOR,SILICON	KTC3199_Y-AT
Q802	72794573	TCATC3199Y	TRANSISTOR,SILICON	KTC3199_Y-AT
Q803	72794573	TCATC3199Y	TRANSISTOR,SILICON	KTC3199_Y-AT
Q804	72795971	TC3F042170	TRANSISTOR,SILICON	2SC4217(D,E)-RAC
Q805	72795971	TC3F042170	TRANSISTOR,SILICON	2SC4217(D,E)-RAC
Q806	72795971	TC3F042170	TRANSISTOR,SILICON	2SC4217(D,E)-RAC
Q1501	72796092	TAAT01281Y	TRANSISTOR,SILICON	KTA1281_Y
Q1502	72795962	TNAAB05003	COMPOUND TRANSISTOR	KRC102SRTK
Q1503	72794571	TCAA3875SY	TRANSISTOR,SILICON	KTC3875S_Y_RTK
Q1504	72794571	TCAA3875SY	TRANSISTOR,SILICON	KTC3875S_Y_RTK
Q1507	72794571	TCAA3875SY	TRANSISTOR,SILICON	KTC3875S_Y_RTK
Q1508	72794571	TCAA3875SY	TRANSISTOR,SILICON	KTC3875S_Y_RTK
Q2201	72794567	TNAAC05002	COMPOUND TRANSISTOR	KRC103SRTK
Q2301	72795964	T67J1036K0	TRANSISTOR,SILICON	2SA1036KT146
Q2302	72795965	T67J048TL0	TRANSISTOR,SILICON	2SA2048TL
Q2303	72794571	TCAA3875SY	TRANSISTOR,SILICON	KTC3875S_Y_RTK
Q2304	72794571	TCAA3875SY	TRANSISTOR,SILICON	KTC3875S_Y_RTK
Q2305	72794571	TCAA3875SY	TRANSISTOR,SILICON	KTC3875S_Y_RTK
▲Q3001	72796092	TAAT01281Y	TRANSISTOR,SILICON	KTA1281_Y
▲Q3002	72796092	TAAT01281Y	TRANSISTOR,SILICON	KTA1281_Y
Q3003	72795962	TNAAB05003	COMPOUND TRANSISTOR	KRC102SRTK
▲Q3005	72794570	TCAT03209Y	TRANSISTOR,SILICON	KTC3209_Y-AT
Q3007	72795962	TNAAB05003	COMPOUND TRANSISTOR	KRC102SRTK
▲Q3008	72795476	TCAT032034	TRANSISTOR,SILICON	KTC3203_Y-AT
Q3800	72794577	TCATC31980	TRANSISTOR,SILICON	KTC3198-AT(Y,GR)
Q3801	72794577	TCATC31980	TRANSISTOR,SILICON	KTC3198-AT(Y,GR)
▲Q3802	72795476	TCAT032034	TRANSISTOR,SILICON	KTC3203_Y-AT
▲Q3803	72795540	T220033260	FET	2SK3326(2)
Q4201	72794571	TCAA3875SY	TRANSISTOR,SILICON	KTC3875S_Y_RTK
Q4202	72795966	TPYJA05001	COMPOUND TRANSISTOR	DTA143EKAT146
Q4203	72794571	TCAA3875SY	TRANSISTOR,SILICON	KTC3875S_Y_RTK
Q4204	72794571	TCAA3875SY	TRANSISTOR,SILICON	KTC3875S_Y_RTK
Q4205	72794558	TNAAD05001	COMPOUND TRANSISTOR	KRC104SRTK
Q4206	72794567	TNAAC05002	COMPOUND TRANSISTOR	KRC103SRTK
<b>COILS &amp; TRANSFORMERS</b>				
L001	72796407	02167D101K	COIL	100 UH
L101	72796582	021LA6560K	COIL	56 UH
L301	72796502	02167B101K	COIL	100 UH
L401	72794527	021679472K	COIL	4.7 MH
L402	72796405	0221000013	COIL,LINEARITY	ELH5L4112N
L601	72794540	02167F101J	COIL	100 UH
L602	72794540	02167F101J	COIL	100 UH
L603	72794540	02167F101J	COIL	100 UH
L604	72796087	02167E100K	COIL	R6-1 10 UH
L801	72794539	02167D151K	COIL	150 UH
L902	72794540	02167F101J	COIL	100 UH
L1502	72796515	02167F221J	COIL	220 UH
L1503	72796515	02167F221J	COIL	220 UH
L1505	72795932	02167F150J	COIL	15 UH
L1508	72794540	02167F101J	COIL	100 UH
L1510	72795932	02167F150J	COIL	15 UH
L1511	72795932	02167F150J	COIL	15 UH
L1512	72796534	0216A6220J	COIL	22 UH
▲L3800	72795933	028R200024	COIL,DEGAUSS	8R200024
L3801	72795934	029X000116	COIL,LINE FILTER	SS28V-R20130
L4001	72795936	02167F2R2J	COIL	2.2 UH
L4002	72796088	02AHB9A972	CORE,FERRITE	W5T29X7.5X19
L4202	72794540	02167F101J	COIL	100 UH
L8102	72795943	02167F1R0K	COIL	1 UH
L8103	72795943	02167F1R0K	COIL	1 UH
T401	72796055	045013003J	TRANS,HORIZONTAL DRIVE	ETH14Y47AY
▲T3800	72796701	0481390314	TRANSFORMER,SWITCHING	81390314
<b>JACKS</b>				
▲J801	72795490	066F130020	SOCKET,CATHODE RAY,TUBE	ISHS53S
▲J2201	72794516	060J131016	HEADPHONE JACK	MSJ-2000_AG
J2202	72795924	060J421036	RCA JACK	MTJ-032-05A-30-FE
J2203	72795925	060J421037	RCA JACK	MTJ-032-05A-32-FE
J2204	72795926	060J421030	RCA JACK	MTJ-032-05A-31-FE

# ELECTRICAL REPLACEMENT PARTS LIST

Location No.	TSB P/N	Reference No.	Description	
<b>JACKS</b>				
J4201	72796734	060J401102	RCA JACK	MSP-251V-05NI-FE-LF
J4203	72794518	060J431020	RCA JACK	MSP-213V2-432_NI_LF
<b>SWITCHES</b>				
SW2213	72794688	0504101T34	SWITCH,TACT	EVQ21505R
SW2214	72794688	0504101T34	SWITCH,TACT	EVQ21505R
SW2215	72794688	0504101T34	SWITCH,TACT	EVQ21505R
SW2216	72794688	0504101T34	SWITCH,TACT	EVQ21505R
SW2217	72794688	0504101T34	SWITCH,TACT	EVQ21505R
SW2218	72794688	0504101T34	SWITCH,TACT	EVQ21505R
SW2219	72794688	0504101T34	SWITCH,TACT	EVQ21505R
SW2220	72794688	0504101T34	SWITCH,TACT	EVQ21505R
SW2221	72794688	0504101T34	SWITCH,TACT	EVQ21505R
SW2223	72794688	0504101T34	SWITCH,TACT	EVQ21505R
<b>VARIABLE RESISTORS</b>				
VR401	72795123	V1K62H3BT8	VOLUME,SEMI FIXED	NVG6THTB222
VR402	72795471	V1K63H3BTE	VOLUME,SEMI FIXED	NVG6TLTAB222
VR3800	72796061	V1K63Q2BTE	VOLUME,SEMI FIXED	NVG6TLTAB471
<b>P.C.BOARD ASSEMBLIES</b>				
PCB110	72783236	A5W301S110L	PCB ASSY	CCE062B
PCB130	72783237	A5W301S130L	PCB ASSY	DME060A
PCBD20	72783238	A5W301SD20L	PCB ASSY	CME066B
<b>MISCELLANEOUS</b>				
B2301	72795787	0246C51024	CORE,BEADS	MMZ1608R102CT
B2302	72795787	0246C51024	CORE,BEADS	MMZ1608R102CT
B2303	72795787	0246C51024	CORE,BEADS	MMZ1608R102CT
B2304	72795787	0246C51024	CORE,BEADS	MMZ1608R102CT
B2305	72795787	0246C51024	CORE,BEADS	MMZ1608R102CT
B3800	72794355	024HT03563	CORE,BEADS	W4BRH3.5X6X1.0X2
B4001	72795787	0246C51024	CORE,BEADS	MMZ1608R102CT
B4002	72795787	0246C51024	CORE,BEADS	MMZ1608R102CT
B4003	72795787	0246C51024	CORE,BEADS	MMZ1608R102CT
B4005	72795787	0246C51024	CORE,BEADS	MMZ1608R102CT
B4006	72795787	0246C51024	CORE,BEADS	MMZ1608R102CT
B4007	72795787	0246C51024	CORE,BEADS	MMZ1608R102CT
B4008	72795787	0246C51024	CORE,BEADS	MMZ1608R102CT
B4009	72795787	0246C51024	CORE,BEADS	MMZ1608R102CT
B4010	72795787	0246C51024	CORE,BEADS	MMZ1608R102CT
B4011	72795787	0246C51024	CORE,BEADS	MMZ1608R102CT
B4012	72795787	0246C51024	CORE,BEADS	MMZ1608R102CT
B4013	72795787	0246C51024	CORE,BEADS	MMZ1608R102CT
B4014	72795787	0246C51024	CORE,BEADS	MMZ1608R102CT
B4016	72795787	0246C51024	CORE,BEADS	MMZ1608R102CT
B4018	72795787	0246C51024	CORE,BEADS	MMZ1608R102CT
B4201	72794357	024HT03553	CORE,BEADS	W5RH3.5X5X1.0
B8103	72795787	0246C51024	CORE,BEADS	MMZ1608R102CT
BL001	72782870	023C00022A	COIL BALUN	HPN-01
BT001	72783174	141U004016	BATTERY,MANGAN	MNAAA(R03)
BT002	72783174	141U004016	BATTERY,MANGAN	MNAAA(R03)
CD301	72782833	06CH123808	CORD,CONNECTOR	CH123808
CD302	72782833	06CH123808	CORD,CONNECTOR	CH123808
CD801	72796912	06CU823001	CORD,CONNECTOR	CU823001
CD802	72798420	WDL6044038	FLAT CABLE AWM2468 A	WG26 6C BLACK 440MM
CD803	72795886	WBL6036038	FLAT CABLE AWM2468 A	WG26 4C BLACK 360MM
CP101	72796804	069S290629	CONNECTOR PCB SIDE	A2001WV2-9P
CP301	72799049	069W120459	CONNECTOR PCB SIDE	213213102W1
CP302	72799049	069W120459	CONNECTOR PCB SIDE	213213102W1
▲CP401	72796822	069S450089	CONNECTOR PCB SIDE	A1561WV2-A5P
CP805	72796816	069S320010	CONNECTOR PCB SIDE	A2361WV2-2P
▲CD3800	72795554	1209414909	CORD,AC BUSH	9414909
CD4002	72783178	06CU2D2202	CORD,CONNECTOR	CU2D2202
CD8101	72797046	122F0C1602	CORD,JUMPER	2F0C1602
CP2301	72783177	069KYOT159	CONNECTOR PCB SIDE	LD07T2-24ND-03
CP2302	72799012	069EV53030	CONNECTOR PCB SIDE	00_6232_005_006_800+
CP2303	72799013	069EV63030	CONNECTOR PCB SIDE	00_6232_006_006_800+
CP3800	72796821	069S420110	CONNECTOR PCB SIDE	A1561WV2-2P
CP8001	72796810	069S2D0629	CONNECTOR PCB SIDE	A2001WV2-13P
CP8002	72796776	069J7C0599	CONNECTOR PCB SIDE	IMSA-9604S-12C
CP802A	72796752	067U006049	WIRE HOLDER	B2013H02-6P
CP802B	72796752	067U006049	WIRE HOLDER	B2013H02-6P
CP803A	72796750	067U004029	WIRE HOLDER	B2013H02-4P
CP803B	72796750	067U004029	WIRE HOLDER	B2013H02-4P
CP8101	72799040	069J7C0589	CONNECTOR PCB SIDE	IMSA-9604S-12F
ELD201	72797069	124116281A	EYE LET	XRY16X28BD
ELD202	72797070	124120301A	EYE LET	XRY20X30BD
▲F3800	72794493	081PC6R305	FUSE	51MS063L

# ELECTRICAL REPLACEMENT PARTS LIST

Location No.	TSB P/N	Reference No.	Description	
<b>MISCELLANEOUS</b>				
▲FB401	72798963	043220059F	TRANSFORMER,FLYBACK	FJN20A003_M
FH3800	72794496	06710T0009	HOLDER,FUSE	EYF-52BCY
FH3801	72794496	06710T0009	HOLDER,FUSE	EYF-52BCY
OS2202	72783180	077A031002	REMOTE RECEIVER	ROM-N3138SR
PH3802	72796825	069W01001A	CONNECTOR PCB SIDE	003P-2100
RY3800	72796047	0560V20115	RELAY	ALKS321
▲SP351	72783225	070W546008	SPEAKER	MSF-18D5SB05
▲SP352	72783225	070W546008	SPEAKER	MSF-18D5SB05
TM101	72783179	076DOMG010	TRANSMITTER	ORT204N7405860-Z
▲TU001	72783175	0163300020	RF UNIT	115-V-KA35ARE
TH3800	72794693	D8EE0B1400	DEGAUSS ELEMENT	B59203-S1060-B14
▲V801	72783226	0981210462	CRT W/DY	A51LYZ295X80
X101	72796990	1002T01606	CERAMIC OSCILLATOR	CSTLS16M0X53-A0
X602	72794704	100DT3R531	CRYSTAL	HC-49/U
X4001	72783182	100GT02720	CRYSTAL	B27000C005

## RESISTOR

RC..... CARBON RESISTOR

## CAPACITORS

CC..... CERAMIC CAPACITOR  
 CE..... ALUMI ELECTROLYTIC CAPACITOR  
 CP..... POLYESTER CAPACITOR  
 CPP..... POLYPROPYLENE CAPACITOR  
 CPL..... PLASTIC CAPACITOR  
 CMP..... METAL POLYESTER CAPACITOR  
 CMPL..... METAL PLASTIC CAPACITOR  
 CMPP..... METAL POLYPROPYLENE CAPACITOR

# **TOSHIBA CORPORATION**

1-1, SHIBAURA 1-CHOME, MINATO-KU, TOKYO 105-8001, JAPAN