

TOSHIBA

FILE NO. 020-200108

SERVICE MANUAL

COLOR TELEVISION

N1NS Chassis

36AFX61, 32AFX61

(TAC0125)

(TAC0126)

TABLE OF CONTENTS

CHAPTER 1 GENERAL ADJUSTMENTS

SAFETY INSTRUCTIONS	3
SET-UP ADJUSTMENT	4
SERVICE MODE	8
ELECTRICAL ADJUSTMENTS	11
CIRCUIT CHECKS	13

CHAPTER 2 SPECIFIC INFORMATIONS

SETTING & ADJUSTING DATA	14
LOCATION OF CONTROLS	15
PROGRAMMING CHANNEL MEMORY	17
CIRCUIT BLOCK DIAGRAM	18
CHASSIS AND CABINET REPLACEMENT PARTS LIST	19
PC BOARDS BOTTOM VIEW	31
TERMINAL VIEW OF TRANSISTORS	39
SPECIFICATIONS	41

APPENDIX:

CIRCUIT DIAGRAM

SAFETY INSTRUCTIONS

WARNING: BEFORE SERVICING THIS CHASSIS, READ THE “X-RAY RADIATION PRECAUTION”, “SAFETY PRECAUTION” AND “PRODUCT SAFETY NOTICE” INSTRUCTIONS BELOW.

X-RAY RADIATION PRECAUTION

- Excessive high voltage can produce potentially hazardous X-RAY RADIATION. To avoid such hazards, the high voltage must not be above the specified limit. The nominal value of the high voltage of this receiver is (A) kV at zero beam current (minimum brightness) under a 120V AC power source. The high voltage must not, under any circumstances, exceed (B) kV.
- This receiver is equipped with a Fail Safe (FS) circuit which prevents the receiver from producing an excessively high voltage even if the B+ voltage increases abnormally. Each time the receiver is serviced, the FS circuit must be checked to determine that the circuit is properly functioning, following the FS CIRCUIT CHECK procedure in this manual.
- The only source of X-RAY RADIATION in this TV receiver is the picture tube. For continued X-RAY RADIATION protection, the replacement tube must be exactly the same type tube as specified in the parts list.
- Some part in this receiver have special safety-related characteristics for X-RAY RADIATION protection. For continued safety, parts replacement should be undertaken only after referring to the PRODUCT SAFETY NOTICE below.

Refer to table-1 for high voltage (A), (B).
(See SETTING & ADJUSTING DATA on page 14)

Each time a receiver requires servicing, the high voltage should be checked following the HIGH VOLTAGE CHECK procedure in this manual. It is recommended that the reading of the high voltage be recorded as a part of the service record. It is important to use an accurate and reliable high voltage meter.

SAFETY PRECAUTION

WARNING : Service should not be attempted by anyone unfamiliar with the necessary precautions on this receiver. The following are the necessary precautions to be observed before servicing this chassis.

- An isolation Transformer should be connected in the power line between the receiver and the AC line before any service is performed on the receiver.
- Always discharge the picture tube anode to the CRT conductive coating before handling the picture tube. The picture tube is highly evacuated and if broken, glass fragments will be violently expelled. Use shatter proof goggles and keep picture tube away from the unprotected body while handling.
- When replacing a chassis in the cabinet, always be certain that all the protective devices are put back in place, such as; non-metallic control knobs, insulating covers, shields, isolation resistor-capacitor network etc.
- Before returning the set to the customer, always perform an AC leakage current check on the exposed metallic parts of the cabinet, such as antennas, terminals, screwheads, metal overlays, control shafts etc. to be sure the set is safe to operate without danger of electrical shock. Plug the AC line cord directly into a 120V AC outlet (do not use a line isolation transformer during this check). Use an AC voltmeter having 5000 ohms per volt or more sensitivity in the following manner:

Connect a 1500 ohm 10 watt resistor, paralleled by a 0.15 μ F, AC type capacitor, between a known good earth ground (water pipe, conduit, etc.) and the exposed metallic parts, one at a time. Measure the AC voltage across the combination of 1500 ohm resistor and 0.15 μ F capacitor. Reverse the AC plug at the AC outlet and repeat AC voltage measurements for each exposed metallic part. Voltage measured must not exceed 0.3 volts rms. This corresponds to 0.2 milliamp. AC. Any value exceeding this limit constitutes a potential shock hazard and must be corrected immediately.

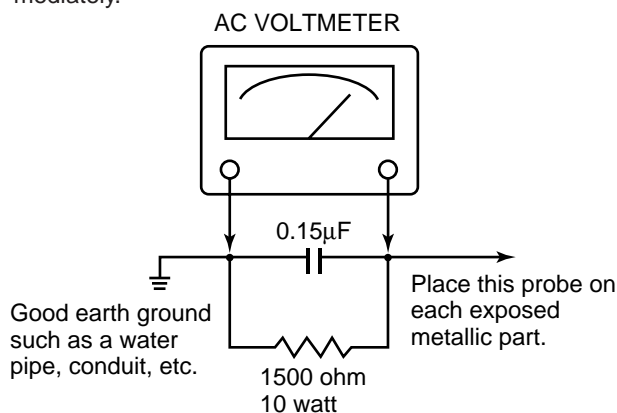

PRODUCT SAFETY NOTICE

Many electrical and mechanical parts in this chassis have special safety-related characteristics. These characteristics are often passed unnoticed by a visual inspection and the protection afforded by them cannot necessarily be obtained by using replacement components rated for higher voltage, wattage, etc. Replacement parts which have these special safety characteristics are identified in this manual and its supplements; electrical components having such features are identified by the international hazard symbols on the schematic diagram and the parts list.

Before replacing any of these components, read the parts list in this manual carefully. The use of substitute replacement parts which do not have the same safety characteristics as specified in the parts list may create shock, fire, X-ray radiation or other hazards.

WARNING: BEFORE SERVICING THIS CHASSIS, READ THE "X-RAY RADIATION PRECAUTION", "SAFETY PRECAUTION" AND "PRODUCT SAFETY NOTICE" ON PAGE 3 OF THIS MANUAL.

SET-UP ADJUSTMENT

- The following adjustments should be made when a complete realignment is required or a new picture tube is installed. Perform the adjustments in order as follows :

1. Color Purity
2. Convergence
3. White Balance

Note: 1. The PURITY/CONVERGENCE MAGNET assembly and rubber wedges need mechanical positioning. Refer to figure 1.

2. Mounting position of the purity magnet assembly should fit to same position as old one because slightly difference to the position depend on a kind of tube.

- * There are no adjustment of purity and convergence in some picture tube (Unified with purity magnet)

COLOR PURITY ADJUSTMENT

NOTE : Before attempting any purity adjustments, the receiver should be operated for at least fifteen minutes.

1. Evenly degauss the entire screen.
2. Set the CONTRAST and BRIGHTNESS Controls to the maximum.
3. Display built-in green raster using the TEST SIGNAL SELECTION function.
4. Loosen the clamp screw holding the deflection yoke (and remove the rubber Wedges).
5. Slide the yoke forward or backward to provide vertical green belt (zone) in the picture screen.
6. Rotate and spread the tabs of the purity magnet (See figure 4.) around the neck of the picture tube until the green belt is in the center of the screen. At the same time, center the raster vertically by adjusting the magnet as shown below.

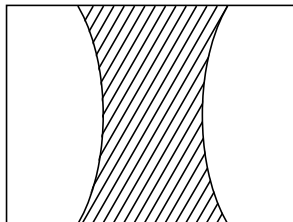

Green Belt

7. Move the yoke slowly forward or backward until a uniform green screen is obtained. Tighten the clamp screw of the yoke temporarily.
8. Check the purity of the red and blue raster.
9. Put four wedges into the space between the picture tube and the yoke to hold the yoke in the adjusted position. (See figure 2.) Do not tilt the yoke by excessive insertion of the wedge.
10. Remove cover paper of wedge and stick wedges on the tube to fix the yoke in the adjusted position. Fix the wedges with glass cloth tapes.

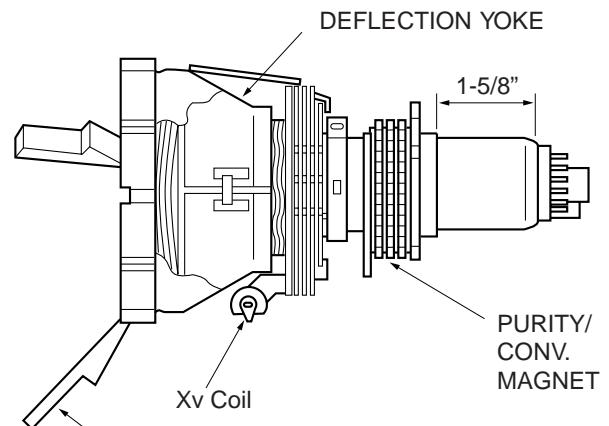

Figure 1.

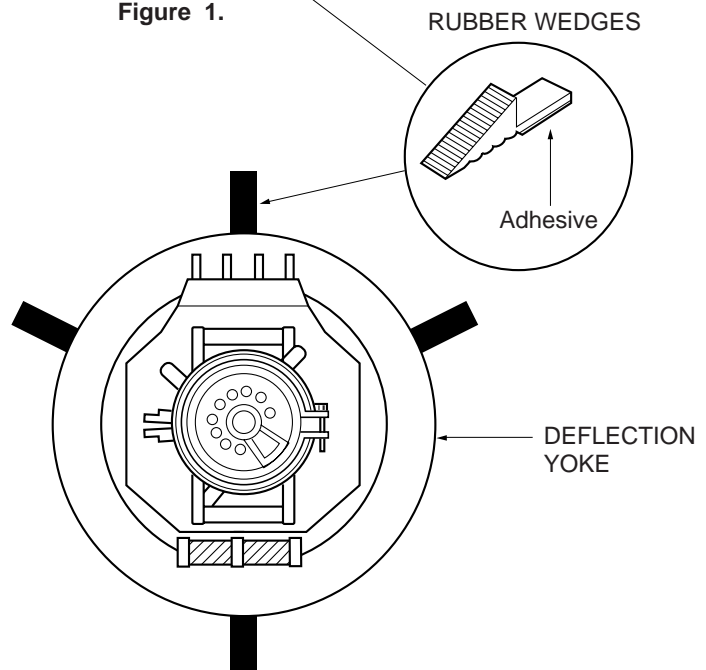

Figure 2.

CONVERGENCE ADJUSTMENTS

NOTE: Before attempting any convergence adjustments, the receiver should be operated for at least fifteen minutes.

■ **CENTER CONVERGENCE ADJUSTMENT**

1. Display built-in cross-dot pattern using the TEST SIGNAL SELECTION function.
2. Adjust the BRIGHTNESS and CONTRAST Controls for well defined pattern.
3. Loosen the tightening ring and adjust two tabs of the 4-Pole Magnets to change the angle between them (See figure 4.) and superimpose red and blue vertical lines in the center area of the picture screen. (See figure 3.)
4. Turn the both tabs at the same time keeping the constant angle to superimpose red and blue horizontal lines at the centre of the screen. (See figure 3.)
5. Adjust two tabs of 6-Pole Magnets to superimpose red/blue line with green one. Adjusting the angle affects the vertical lines and rotating both magnets affects the horizontal lines.
6. Repeat adjustments 3, 4, 5 keeping in mind red, green and blue movement, because 4-Pole Magnets and 6-Pole magnets interact and make dot movement complex.
7. After completing the "CENTER CONVERGENCE ADJUSTMENT" tighten the tightening ring to fix the magnets.

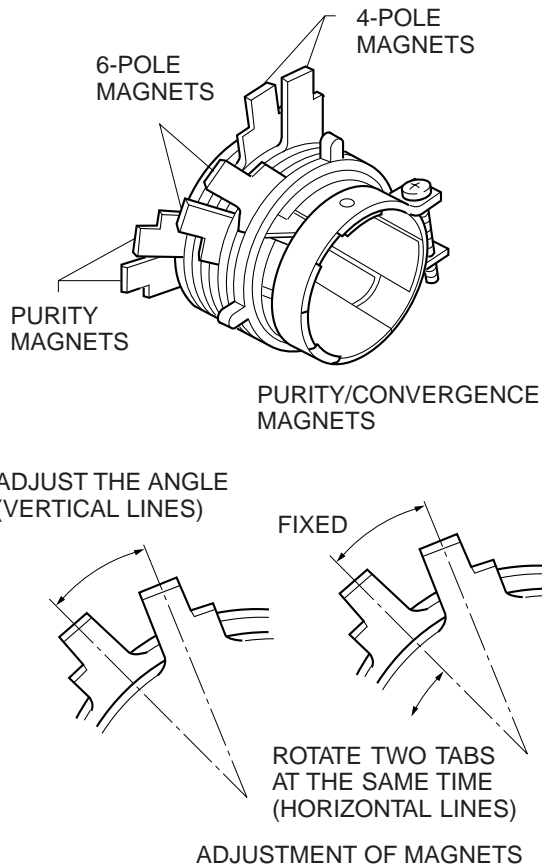
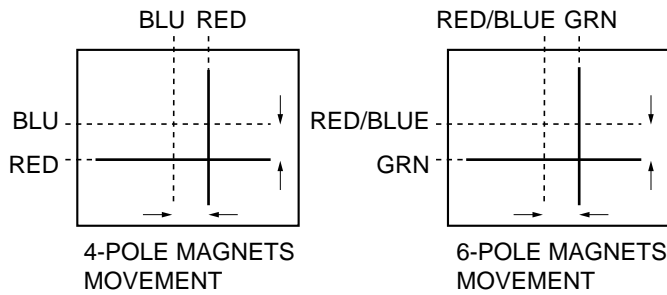

Figure 4.



Center Convergence by Convergence Magnets

Figure 3.

■ **Xv COIL ADJUSTMENT**

Adjust the Xv coil (on the deflection yoke) to correct misconvergence at both sides on screen. Use a hexagonal tip stick (plastic) to adjust the core of coil.

Clockwise Adjustment Counterclockwise Adjustment

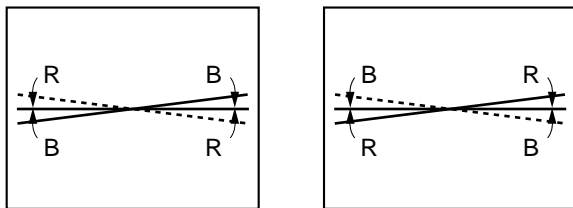

Xv Cross Pattern View

■ **SCREEN-CORNER CONVERGENCE**

When the misconvergence is still evident on corners even though the above adjustment is done, use the ferrite sheet (Part No. 23993622) to correct misconvergence.

1. Put ferrite sheets into the space under the yoke. Decide such position that misconvergence becomes minimum, watching picture screen. (See figure below.)
2. Remove cover paper of ferrite sheet to stick it in the place on the tube. Put adhesive tapes on ferrite sheets to fix.

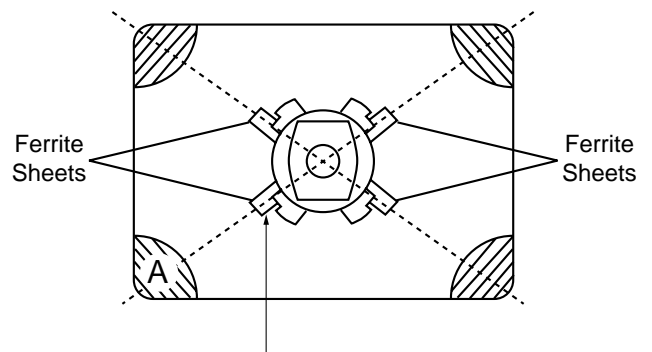

For correcting misconvergence on the position A

WARNING: BEFORE SERVICING THIS CHASSIS, READ THE "X-RAY RADIATION PRECAUTION", "SAFETY PRECAUTION" AND "PRODUCT SAFETY NOTICE" ON PAGE 3 OF SERVICE MANUAL.

SET-UP ADJUSTMENT

- The following adjustments should be made when a complete realignment is required or a new picture tube is installed. Perform the adjustments in order as follows :

1. Color Purity
2. Convergence
3. White Balance

Note: The PURITY/CONVERGENCE MAGNET assembly and rubber wedges need mechanical positioning. Refer to figure 1.

COLOR PURITY ADJUSTMENT

- (1) Let the screen face in the installing direction or toward the east (when it is to be moved), bring up the service mode screen after demagnetizing (front, left, right, and top) with the degaussing coil, receive white signals by pressing the [TV/VIDEO] button, and then the receiver should be operated for more than 40 minutes.
- (2) Perform rough adjustment of the central convergence with the P/C magnet according to the adjustment item.
- (3) Receive built-in green signals, loosen set screws on the deflection yoke, remove rubber wedges, and shift the deflection yoke toward front.
- (4) Move alternately the two 2-pole magnets of the P/C magnets so that the green raster can come to the center of the screen.

Figure 1.

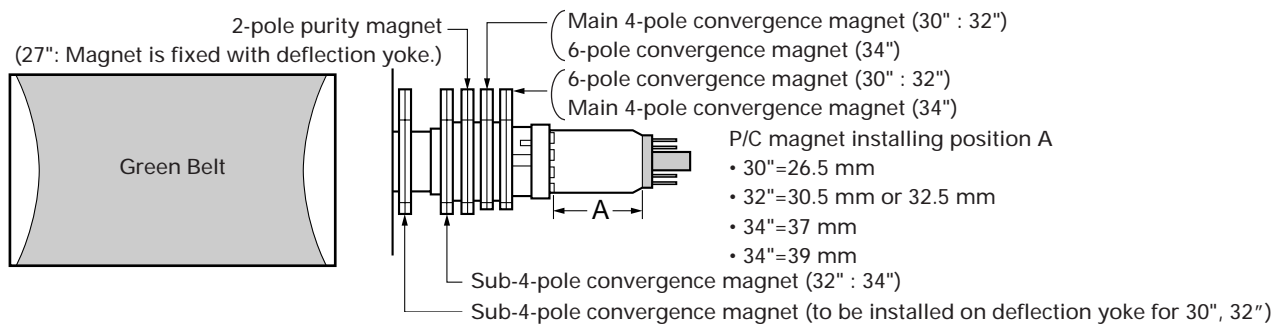

- (5) Receive built-in red and blue signals, check that there is no inclination of the single color raster toward one side, and if each color tilts to a great extent, make adjustment with the 2-pole magnet so that the 3 colors will come to the center evenly.
- (6) Receive the green raster, shift the deflection yoke from a foremost position (hitting against the picture tube) to a backward position horizontally, stop the deflection yoke at a position where it begins to become a green raster, and perform accurate marking on the picture tube.
- (7) Shift the deflection yoke further backward, and perform accurate marking at a position where the green raster begins to be luk.
- (8) Fix the deflection yoke at a position 60% forward within the range marked in items (6) and (7) above.

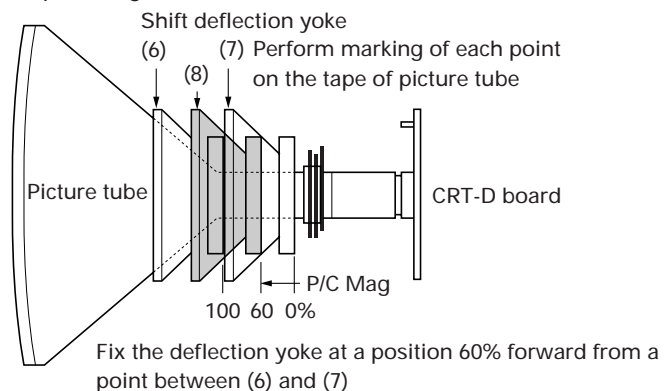

CONVERGENCE ADJUSTMENTS

* Adjust the convergence magnet to get vest convergence in the the order to (1) ~ (5).

■ CENTER CONVERGENCE:

- (1) Receive the white crosshatch or dot pattern from the service signal generator.
- (2) Use the 2 pieces of main 4-pole magnets of P/C magnets, change the open angle, and align the red and blue vertical lines on the screen center.
- (3) Freeze the open angle of the main 4-pole magnets, turn them simultaneously, and align the horizontal lines.
- (4) Take the same steps for items (2) and (3) above and align red/blue with green on the screen center using two 6-pole magnets.

(5) Adjust the sub-4-pole magnets only in case there is any deviation of Xv bow-shaped convergence. (To be usually set at the initial position)
Align both sides with the sub-4-pole magnets and minimize the deviation of blue and red with the main 4-pole magnets.

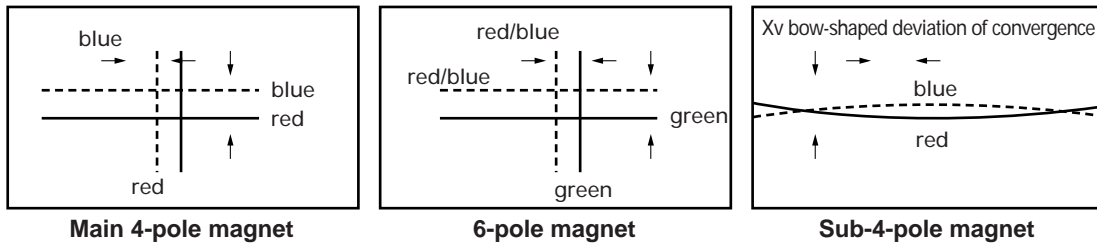

■ CIRCUMFERENCE CONVERGENCE:

* Perform correction in the following manner.

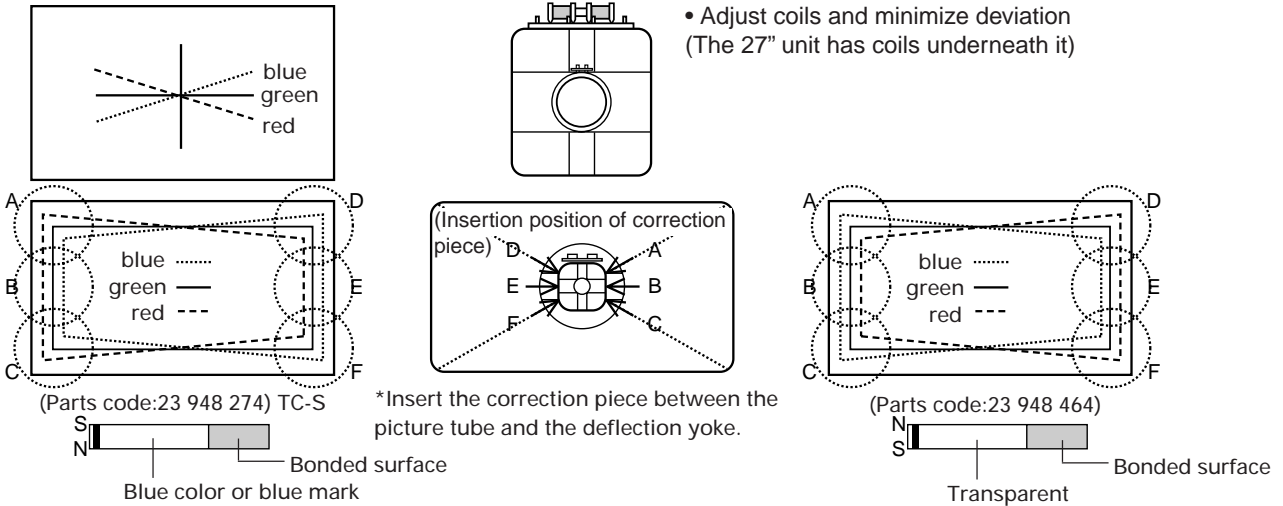

Adjust VR 1 and minimize the deviation of YH. *Only 27", 30" and 32".



Adjust VR 2 (YHC) and minimize the deviation of YH.

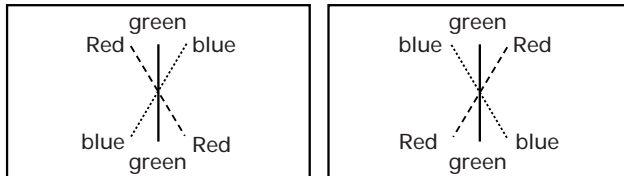

Adjust VR 3 (YV) and minimize the deviation of YV.

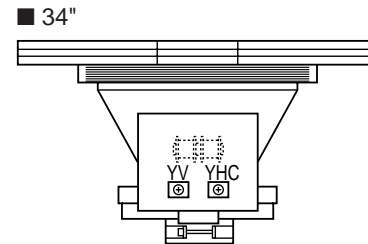
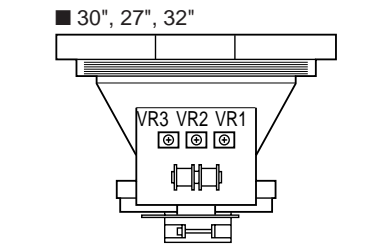
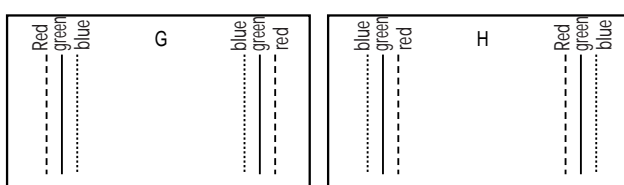
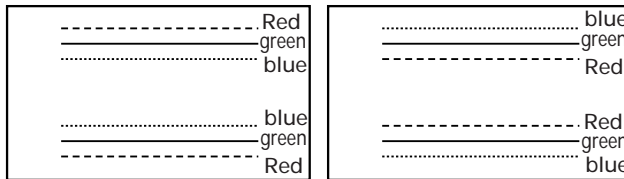

- 27" (Part No. 23 947 371)
- 32", 30" (Part No. 23 947 121)
- 34" (Part No. 23 993 080)

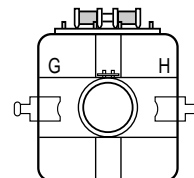

Perform correction by inserting the correction piece into the clearance of terminal board coils of the deflection yoke.

Note:

Perform insertion by turning the metal side to the terminal board side of the deflection yoke.

SERVICE MODE

1. ENTERING TO SERVICE MODE

- 1) Press MUTE button once on Remote Control.
- 2) Press MUTE button again to keep pressing.
- 3) While pressing the MUTE button, press MENU button on TV set.

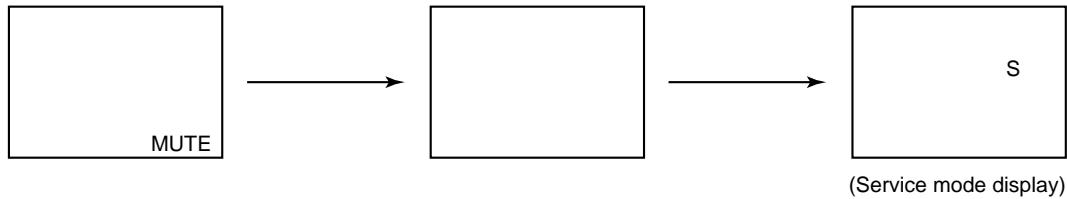

2. DISPLAYING THE ADJUSTMENT MENU

- 1) Press MENU button on TV.

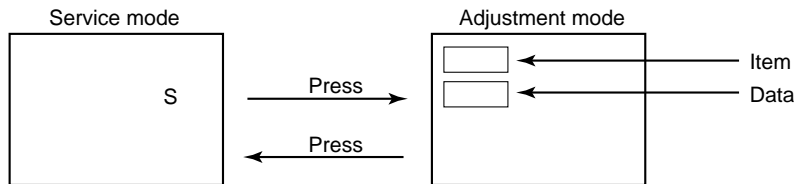

3. KEY FUNCTION IN THE SERVICE MODE

The following key entry during display of adjustment menu provides special functions.

A single horizontal line ON/OFF:	TV (ANT)/VIDEO button (on TV)
Test signal selection :	TV (ANT)/VIDEO button (on Remote)
Selection of the adjustment items :	Channel ▲/▼ (on TV or Remote)
Change of the data value :	Volume ▲/▼ (on TV or Remote)
Adjustment menu mode ON/OFF :	MENU button (on TV)
Initialization of the memory (QA02, QA04) :	RECALL+Channel (▲) button on TV
Initialization of the self diagnostic data:	RECALL+Channel (▼) button on TV

"RCUT" selection :	1 button
"GCUT" selection :	2 button
"BCUT" selection :	3 button
"CNTX" selection :	4 button
"COLC" selection :	5 button
"TNTC" selection :	6 button
Test audio signal ON/OFF (1kHz) :	8 button
Self diagnostic display ON/OFF :	9 button

4. SELECTING THE ADJUSTING ITEMS

- 1) Every pressing of CHANNEL ▲ button in the service mode changes the adjustment items in the order of table-2. (▼ button for reverse order)

Refer to table-2 for preset data of adjustment mode.
(See SETTING & ADJUSTING DATA on page 14)

5. ADJUSTING THE DATA

- 1) Pressing of VOLUME ▲ or ▼ button will change the value of data in the range from 00H to FFH. The variable range depends on the adjusting item.

6. EXIT FROM SERVICE MODE

- 1) Pressing POWER button to turn off the TV once.

■ INITIALIZATION OF MEMORY DATA OF QA02 AND QA04

After replacing QA02 and QA04, the following initialization is required.

1. Enter the service mode, then select any register item.
2. Press and hold the RECALL button on the Remote, then press the CHANNEL ▲ button on the TV. The initialization of QA02 and QA04 has been completed.
3. Check the picture carefully. If necessary, adjust any adjustment item above.
Perform "Programming Channel Memory" on the owner's manual.

CAUTION: Never attempt to initialize the data unless QA02, QA04 has been replaced.

7. TEST SIGNAL SELECTION

- 1) Every pressing of TV/VIDEO button on the Remote Control in the Service mode changes the built-in test patterns on screen in the following order.

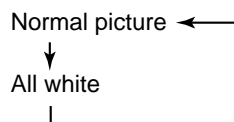

Signals	Picture
• All White	

- 2) Press "8" button while any built-in test pattern to on the screen to output the 1 kHz sound. Press the button again to cut off the sound.

Note: If the video cable is connected to the VIDEO1 INPUT jack, the built-in pattern signals are not displayed.

8. SELF DIAGNOSTIC FUNCTION

- 1) Press "9" button on Remote Control during display of adjustment menu in the service mode.
The diagnosis will begin to check if interface among IC's are executed properly.
- 2) During diagnosis, the following displays are shown.

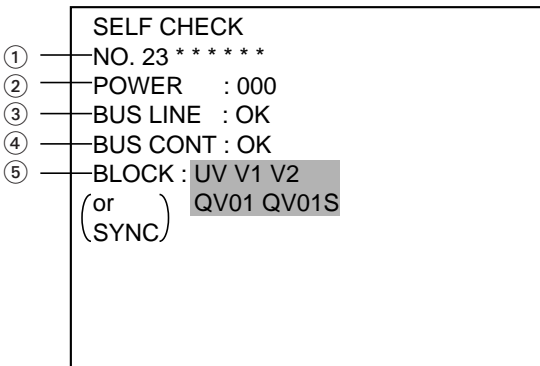

- ① Part number of microprocessor (QA01)
- ② Operation number of protection circuit (current limiter) . . . "000" is normal.
- ③ BUS line check — "OK" Normal
 "SC-L-GND" or "NG" SC-L-GND short circuit
 "SC-A-GND" or "NG" SC-A-GND short circuit
 "SC-L-SC-A" or "NG" SC-L-SC-A short circuit
- ④ BUS line ACK (acknowledge) check
 "OK" Normal
 Display of Location Number . . . NG
 (Display example)
 "QA02 NG", "H001 NG", "Q501 NG" etc.
 Note: The indication of failure place is only one place though failure places are plural. When
 repair of a failure place finishes, the next failure place is indicated. (The order of priority of
 indication is left side.)
- ⑤ Sync. signal check — Green display Normal
 Cyan display No check
 Red display NG
 [UV TV mode
 V1 VIDEO 1 mode
 V2 VIDEO 2 mode]

* The items marked with ■ are not usable to display in the SELF DIAGNOSTIC FUNCTION for some model.

ELECTRICAL ADJUSTMENTS

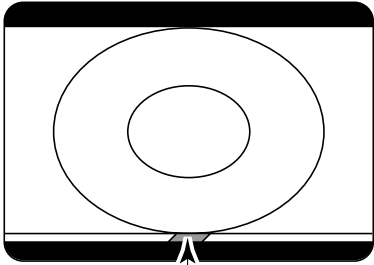
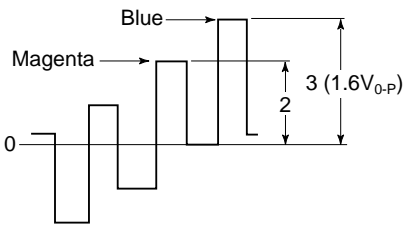
ITEM	ADJUSTMENT PROCEDURE
FOCUS VR ADJ	<ol style="list-style-type: none"> 1. Enter the service mode, then select any register item. 2. Press the TV/VIDEO button on the Remote until the black cross-bar pattern appears on the screen. 3. Adjust the FOCUS control (on T461) for well defined scanning lines on the picture screen.
SUB-BRIGHTNESS (BRTC)	<ol style="list-style-type: none"> 1. Constrict the picture height until the vertical retrace line appears adjusting the item HIT (HEIGHT). 2. Adjust the CONTRAST control to the minimum. 3. Call up the adjustment mode display, then select the item BRTC. 4. Press the VOLUME ▲ or ▼ button so the belt of vertical retrace line just disappear. 5. Adjust the CONTRAST control for the desired contrast. 6. Perform the HEIGHT adjustment. <div style="text-align: center;">  <p style="text-align: center;">Vertical retrace line</p> </div>
SUB-COLOR (SCOL) SUB-TINT (TNTC)	<ol style="list-style-type: none"> 1. Receive color-bar signal from color-bar generator. 2. Press the RESET button. 3. Connect oscilloscope to TP501 on SIGNAL board. 4. Adjust the CONTRAST control to the minimum. 5. Call up the adjustment mode display, then select the item TNTC. 6. Adjust the SUB-TINT by pressing the VOLUME ▲ or ▼ button to obtain a blue bar to magenta bar ratio of 3:2 as shown. 7. Press the RESET button. 8. Select the item SCOL. 9. Adjust the SUB-COLOR by pressing the VOLUME ▲ or ▼ button to achieve 1.6V_{0-p} of a blue bar on scope. 10. Check the picture with off-air signal. <div style="text-align: center;">  </div>
WIDTH (WID)	<ol style="list-style-type: none"> 1. Call up the adjustment mode display, then select the item WID. 2. Press the VOLUME ▲ or ▼ button to get the picture so the left and right edges of raster begins to lack. 3. Press the VOLUME ▲ or ▼ button to advance the data by 7 steps. <p>Note : Check the horizontal picture position is correct.</p>

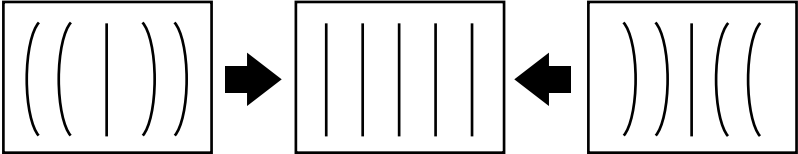
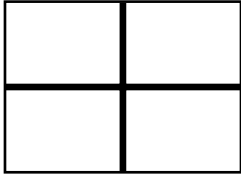
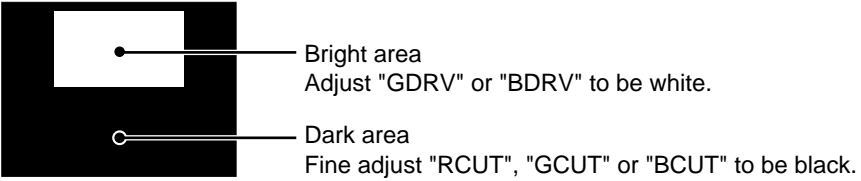
ITEM	ADJUSTMENT PROCEDURE
<p>E-W PARABOLA (DPC) (PARA)</p>	<ol style="list-style-type: none"> 1. Call up the adjustment mode display, then select the item PARA. 2. Press the TV/VIDEO button on Remote until the cross-hatch pattern appears on the screen. 3. Press the VOLUME ▲ or ▼ button to make vertical lines straight as shown below. <div style="text-align: center;">  </div>
<p>HORIZONTAL POSITION (HPOS) VERTICAL POSITION (VPOS)</p>	<ol style="list-style-type: none"> 1. Call up the adjustment mode display, then select the item HPOS or VPOS. 2. Press the TV/VIDEO button on Remote until the white cross-bar or black cross-bar pattern appears on the screen. 3. Adjust the HORIZONTAL and VERTICAL position alternately by pressing the VOLUME ▲ or ▼ button for proper picture position. 4. Check the picture with off-air signal. <div style="text-align: right;">  </div>
<p>HEIGHT (HIT)</p>	<ol style="list-style-type: none"> 1. Call up the adjustment mode display, then select the item HIT. 2. Press the VOLUME ▲ or ▼ button to get the picture so the top of raster begins to lack. 3. Press the VOLUME ▲ button to advance the data by 9 steps. <p>Note : Check the vertical picture position is correct.</p>
<p>WHITE BALANCE (RCUT) (GCUT) (BCUT) (GDRV) (BDRV)</p>	<ol style="list-style-type: none"> 1. Adjust the CONTRAST control to the center, and BRIGHTNESS control to the maximum. 2. Call up the adjustment mode display, and press the TV/VIDEO button on Remote until the white and black pattern appears on the screen. 3. Adjust the following items with the CHANNEL ▲/▼ and VOLUME ▲/▼ buttons. <ul style="list-style-type: none"> Item : RCUT → Data : 40H Item : GCUT → Data : 40H Item : BCUT → Data : 40H Item : GDRV → Data : 40H Item : BDRV → Data : 40H 4. Press the TV/VIDEO button on TV to display a single horizontal line on the screen. 5. Turn the SCREEN control (FBT) fully counterclockwise and gradually rotate clockwise until the first horizontal line appears slightly on the screen. 6. Press the TV/VIDEO button to display the normal picture. 7. Adjust the remaining two "?CUT" items (CHANNEL ▲/▼ → TV/VIDEO → VOLUME ▲/▼ in order) to obtain the slightly lighted horizontal line in the same levels of three (red, green, blue) colors. The line should be white if the adjustments are proper. <div style="margin-top: 20px;">  </div>

CIRCUIT CHECKS

HIGH VOLTAGE CHECK

CAUTION: There is no HIGH VOLTAGE ADJUSTMENT on this chassis. Checking should be done following the steps below.

1. Connect an accurate high voltage meter to the second anode of the picture tube.
2. Turn on the receiver. Set the BRIGHTNESS and CONTRAST controls to minimum (zero beam current).
3. High voltage must be measured below (B) kV.

Refer to table-1 for high voltage (B).
(See SETTING & ADJUSTING DATA on page 14)

4. Vary the BRIGHTNESS control to both extremes to be sure the high voltage does not exceed the limit under any conditions.

FS CIRCUIT CHECK

The Fail Safe (FS) circuit check is indispensable for the final check in servicing. Checking should be done following the steps below.

1. Turn the receiver on and press the RESET button.
2. Temporarily short TP-(R) and TP-(X) with a jumper wire. Raster and sound will disappear.
3. The receiver must remain in this state even after removing the jumper wire. This is the evidence that the FS circuit is functioning properly.
4. To obtain a picture again, temporarily turn the receiver off and allow the FS circuit more than 5 seconds to reset. Then turn the power switch on to produce a normal picture.

Troubleshooting Guide for Fail Safe Circuit

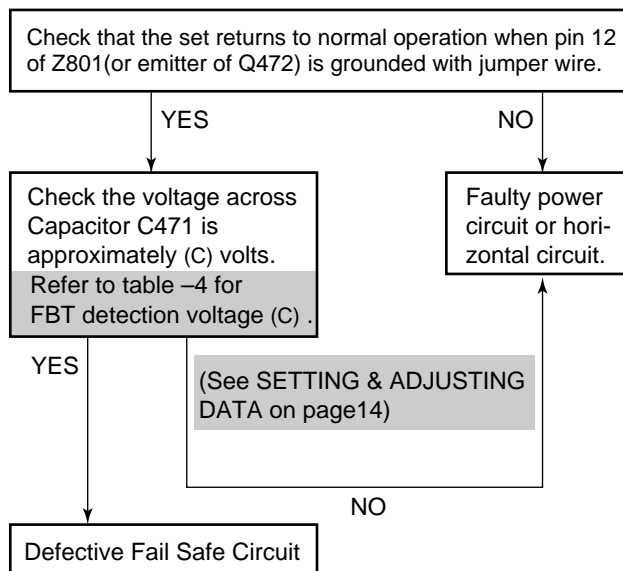

CHAPTER 2 SPECIFIC INFORMATIONS

SETTING & ADJUSTING DATA

【SAFETY INSTRUCTIONS】

		36"
HIGH VOLTAGE AT ZERO BEAM:	(A)	32.7 kV
MAX HIGH VOLTAGE:	(B)	34.1 kV

Table-1

【SERVICE MODE】

ADJUSTING ITEMS AND DATAS IN THE SERVICE MODE:

Item	Name of adjustment	Preset	Data	Item	Name of adjustment	Preset	Data
RCUT	R CUTOFF	40H	←	CNR	E-W CORNER	11H	15H
GCUT	G CUTOFF	40H	←	TRAP	TRAPEZIUM	3EH	←
BCUT	B CUTOFF	40H	←	HCP	H-COMPENSATION	04H	02H
GDRV	G DRIVE	40H	←	VFC	V-F CORRECTION	07H	←
BDRV	B DRIVE	40H	←	HPOS	H-POSITION	16H	14H
BRTC	BRIGHT CENT	80H	←	VPOS	V-PHASE	03H	←
TNTC	TINT CENT	44H	←	BLKS	BLANKING START	—	←
SCOL	SUB-COLOR	05H	←	BLKE	BLANKING END	—	←
SCNT	SUB-CONTRAST	10H	←	GMPS	GMPS	00H	←
HIT	HEIGHT	47H	36H	CPAR	CENTER PARA	55H	33H
LIN	V-LINEARITY	13H	←	PHUE	PIP TINT	46H	←
VSC	V-S CORRECTION	31H	33H	PCNT	PIP CONTRAST	12H	←
VPS	V-SHIFT	04H	←	PCOL	PIP COLOR	19H	←
VCP	V-COMPENSATION	03H	←	PYOF	PIP Y OFFSET	04H	←
WID	PICTURE WIDTH	21H	25H	PIOF	PIP I OFFSET	1DH	←
PARA	E-W PARABOLA	22H	17H	PQOF	PIP Q OFFSET	1DH	←

Table-2

【DESIGN MODE】

ADJUSTING ITEMS AND DATAS IN THE DESIGN MODE:

Item	Name of adjustment	Preset Data			Remarks
		PRESET	36"	32"	
OPT1	OPTION 1	4AH	←	88H	
OPT2	OPTION 2	05H	←	0DH	
TVOP	MAIN TUNER for STOP SUB TUNIER for STOP Non-Signal Audio Mute (0: on 1: off)	00H	←	←	

Table-3

【CIRCUIT CHECKS】

FBT DETECTION VOLTAGE	(C)	18.9 V
-----------------------	-----	--------

Table-4

LOCATION OF CONTROLS (Representative: 36AFX61)

TV Front

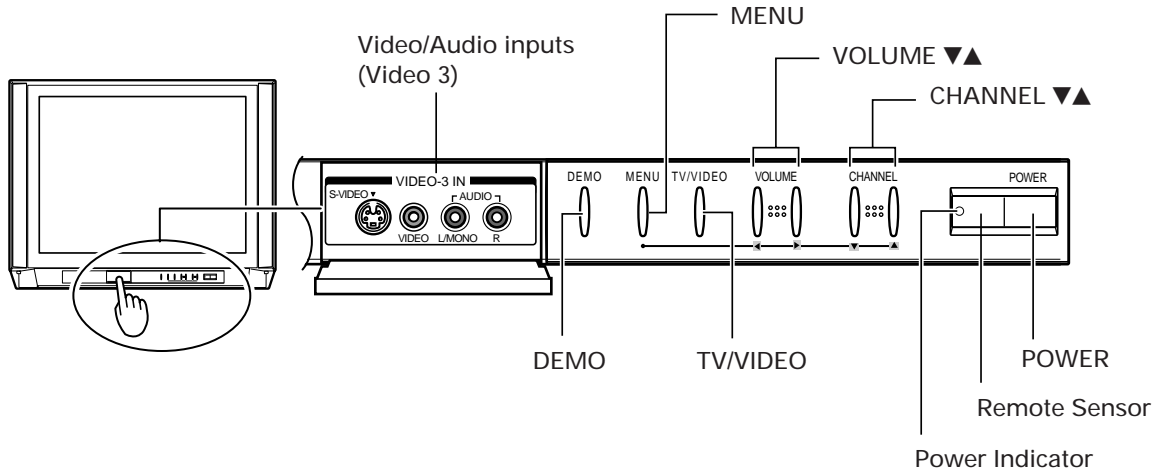

TV Rear

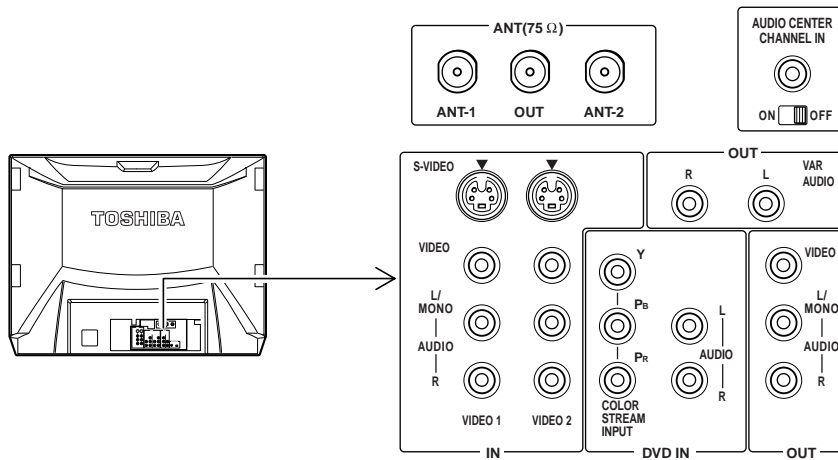

Remote Control

Power turns the TV on or off

SLEEP sets the TV to turn at a specific time

LIGHT The initial press of the LIGHT button causes two actions:

Channel Numbers (0–9, 100) allow direct access to channels

MODE cycles through the 6 device modes

FAVOURITE allows access to Multi-Window function

INFO allows access to Multi-Window function

MENU allows access to programming

ENTER sets programming menu information

▲▼◀▶ selects or adjusts programming menus

[FAV] ◀▶ selects your favourite channels

Volume ▲▼ adjusts the volume level

EXIT exits programming menus

Channel ▲▼ cycles through programmed channels

CH RTN returns to the last viewed channels

RECALL displays on-screen information

MUTE mutes the sound

INPUT selects video input source

PIP allows access to PIP functions

PIP turns the PIP on or off

PIP CH ▲▼ selects the PIP channels

MULTI allows access to Multi-Windows function

STILL freezes the PIP

SOURCE selects the PIP source

LOCATE moves the PIP

SWAP switches the PIP and main pictures

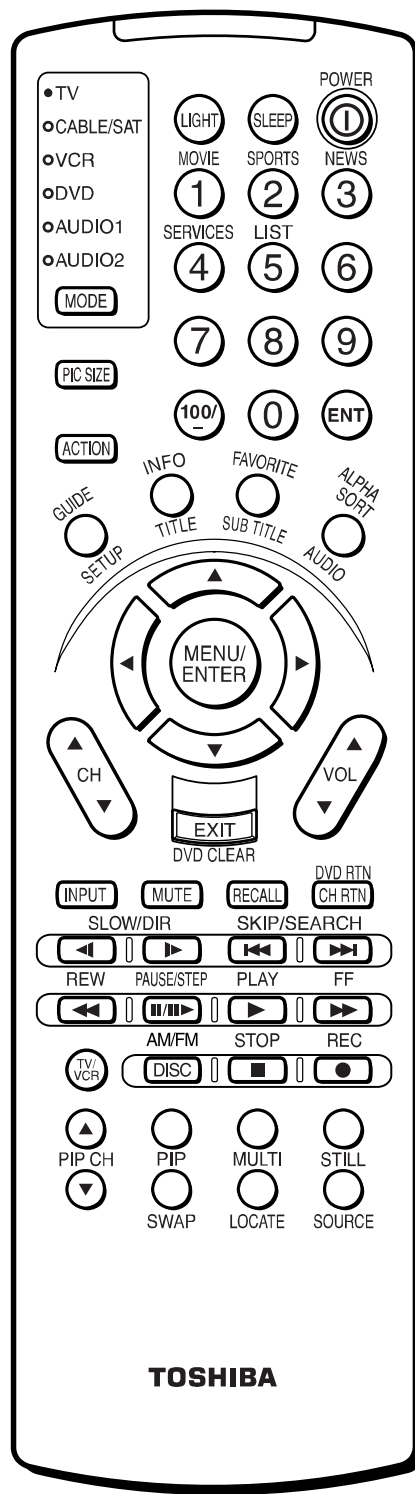

PROGRAMMING CHANNEL MEMORY

The channel memory is the list of TV channel numbers your TV will stop on when you press the CHANNEL ▲ or ▼ button.

First, use the TV/CABLE and CH PROGRAM functions to preset all active channels in your area automatically.

If necessary, arrange the preset channels with the ADD/ERASE functions so that you can tune into only desired channels.

Note: If you utilize both ANT-1 and ANT-2 terminals for some model, perform programming channels for each input source.

TV/CABLE function

- 1 Press **MENU**, then press ► or ◀ until the SET UP menu appears.
- 2 Press ▼ (or ▲) until "TV/CABLE" is highlighted.
- 3 Press ► or ◀ to highlight either "TV" or "CABLE", whichever you use.

CH PROGRAM function

- 1 Select "CH PROGRAM" following steps 1 and 2 above.
- 2 Press ► or ◀ to start channel programming.
The TV will automatically cycle through all the TV or CABLE channels selected by the TV/CABLE function, and store active channels in the channel memory.
- 3 When channel programming is complete, you will see the message to the right.
- 4 Press **CHANNEL ▲** or **▼** to make sure the channel programming has been done properly.

ADD/ERASE function

After performing the CH PROGRAM function, you can add or erase specific channels.

- 1 Select the channel you want to erase using the CHANNEL ▲ or ▼ button, or select the channel you want to add using the **Channel Number** buttons.
- 2 Press **MENU**, then press ► or ◀ until the SET UP menu appears.
- 3 Press ▼ (or ▲) until "ADD/ERASE" is highlighted.
- 4 Press ► or ◀ :
To erase the channel
Press the button until "Erase" is highlighted.
To add the channel
Press the button until "Add" is highlighted.
- 5 Repeat steps 1 to 4 for other channels.

You have now completed the channel programming.

Note: The CHANNEL ▼/▲ buttons on the TV function as the ▼/▲ buttons while a menu is on the screen.

* Please refer to owner's manual in detail.

CIRCUIT BLOCK DIAGRAM

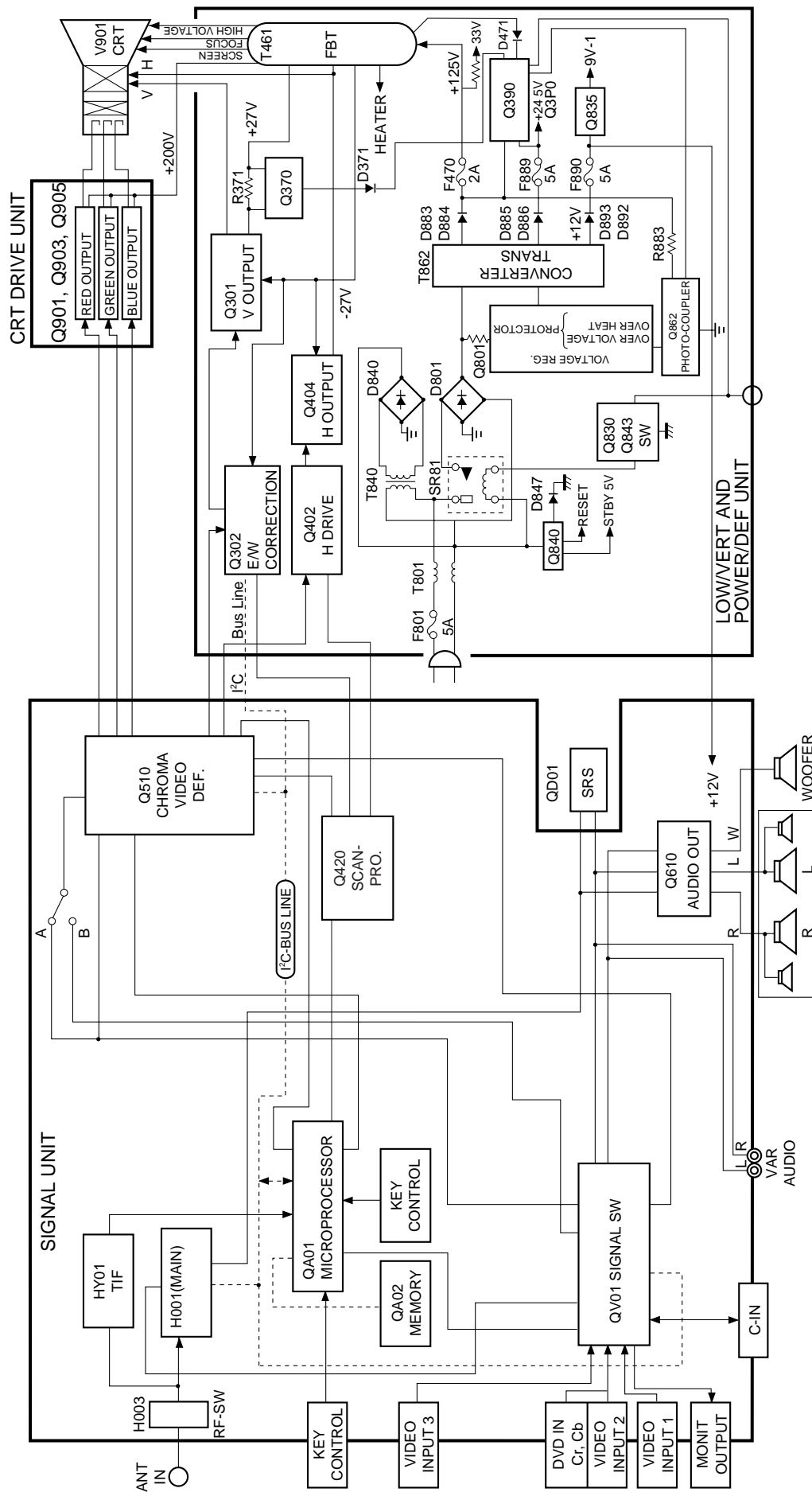

CHASSIS AND CABINET REPLACEMENT PARTS LIST

WARNING: BEFORE SERVICING THIS CHASSIS, READ THE "X-RAY RADIATION PRECAUTION", "SAFETY PRECAUTION" AND "PRODUCT SAFETY NOTICE" ON PAGE 3 OF THIS MANUAL.

CAUTION: The international hazard symbols "⚠" in the schematic diagram and the parts list designate components which have special characteristics important for safety and should be replaced only with types identical to those in the original circuit or specified in the parts list. The mounting position of replacements is to be identical with originals. Before replacing any of these components, read carefully the PRODUCT SAFETY NOTICE. Do not degrade the safety of the receiver through improper servicing.

NOTICE:

- The part number must be used when ordering parts, in order to assist in processing, be sure to include the Model number and Description.
- The PC board assembly with * mark is no longer available after the end of the production.

Model : 36AFX61/32AFX61

Capacitors	CD : Ceramic Disk	PF : Plastic Film	EL : Electrolytic
Resistors	CF : Carbon Film	CC : Carbon Composition	MF : Metal Film
	OMF : Oxide Metal Film	VR : Variable Resistor	FR : Fusible Resistor

(All CD and PF capacitors are ±5%, 50V and all resistors, ±5%, 1/6W unless otherwise noted.)

Location No.	Part No.	Description
CAPACITORS		
C102	24665221	EL, 220µF, ±20%, 10V
C105	24474102	CD, 1000pF, ±10%
C106	24669479	EL, 4.7µF, ±20%, 50V
C107	24666221	EL, 220µF, ±20%, 16V
C112	24665221	EL, 220µF, ±20%, 10V
C115	24474102	CD, 1000pF, ±10%
C117	24666221	EL, 220µF, ±20%, 16V
C151	24436102	CD, 1000pF
C201	24794100	EL, 10µF, ±20%, 16V
C203	24503041	PF, 0.1µF, 63V
C204	24797010	EL, 1µF, ±20%, 50V
C205	24206229	EL, 2.2µF, ±20%, 50V
C206	24206108	EL, 0.1µF, ±20%, 50V
C207	24436390	CD, 39pF
C208	24436390	CD, 39pF
C209	24436390	CD, 39pF
C212	24794100	EL, 10µF, ±20%, 16V
C213	24206010	EL, 1µF, ±20%, 50V
C214	24794220	EL, 22µF, ±20%, 16V
C260	24085967	EL, 47µF, ±20%, 16V, Non-Polar
C303	24214471	CD, 470pF, ±10%, 500V
C304	24693473	PF, 0.047µF, 100V
C306	24795332	EL, 3300µF, ±20%, 25V
C308	24797221	EL, 220µF, ±20%, 50V
C310	24073095	EL, 2200µF, ±20%, 50V
C312	24591473	PF, 0.047µF
C313	24082057	PF, 0.22µF, 100V
C314	24793101	EL, 100µF, ±20%, 10V
C315	24797229	EL, 2.2µF, ±20%, 50V
C316	24212222	CD, 2200pF, ±10%
C318	24073041	EL, 470µF, ±20%, 16V
C319	24591103	PF, 0.01µF
C320	24797101	EL, 100µF, ±20%, 50V
C322	24617912	EL, 2.2µF, ±10%, 50V
C323	24539474	PF, 0.47µF
C325	24591203	PF, 0.02µF
C327	24073041	EL, 470µF, ±20%, 16V
C328	24591563	PF, 0.056µF (36AFX61)
C328	24591472	PF, 4700pF (32AFX61)

Location No.	Part No.	Description
C352	24617915	EL, 1µF, ±10%, 50V
C361	24567474	PF, 0.47µF (36AFX61)
C361	24591473	PF, 0.047µF (32AFX61)
C366	24693154	PF, 0.15µF, 100V
C370	24794101	EL, 100µF, ±20%, 16V
C371	24794100	EL, 10µF, ±20%, 16V
C391	24666100	EL, 10µF, ±20%, 16V
C393	24666100	EL, 10µF, ±20%, 16V
C396	24082825	PF, 1800pF, ±3%, 1800V
C399	24085981	EL, 10µF, ±20%, 16V, Non-Polar
C401	24503041	PF, 0.1µF, 63V
C403	24503041	PF, 0.1µF, 63V
C404	24797229	EL, 2.2µF, ±20%, 50V
C413	24214821	CD, 820pF, ±10%, 500V
C415	24591392	PF, 3900pF
C416	24678010	EL, 1µF, ±20%, 200V
C417	24214391	CD, 390pF, ±10%, 500V
C420	24666101	EL, 100µF, ±20%, 16V
C423	24829433	PF, 0.043µF, 400V (36AFX61)
C423	24829393	PF, 0.039µF, 400V (32AFX61)
C430	24232103	CD, 0.01µF, +80%, -20%
C431	24794101	EL, 100µF, ±20%, 16V
△C440	24082592	PF, 1000pF, ±3%, 1800V
C441	24082917	PF, 0.3µF, 315V
△C442	24082925	PF, 0.62µF, 315V (36AFX61)
△C442	24082821	PF, 1200pF, ±3%, 1800V (32AFX61)
△C443	24082961	PF, 8200pF, ±3%, 1500V (36AFX61)
△C443	24082608	PF, 4700pF, ±3%, 1800V (32AFX61)
△C444	24082957	PF, 7500pF, ±3%, 1500V (36AFX61)
△C444	24082616	PF, 0.03µF, ±3%, 1800V (32AFX61)
C445	24828473	PF, 0.047µF, 200V
C446	24679330	EL, 33µF, ±20%, 250V
C447	24829473	PF, 0.047µF, 400V
C448	24640962	EL, 33µF, ±20%, 200V
C463	24212152	CD, 1500pF, ±10%

Location No.	Part No.	Description
C464	24640872	EL, 10 μ F, \pm 20%, 100V
C465	24212472	CD, 4700pF, \pm 10% (32AFX61)
C466	24503041	PF, 0.1 μ F, 63V
△C467	24082855	PF, 0.047 μ F, \pm 3%, 630V (36AFX61)
△C467	24820243	PF, 0.024 μ F, 630V (32AFX61)
C471	24206479	EL, 4.7 μ F, \pm 20%, 50V
C472	24539474	PF, 0.47 μ F
C474	24794100	EL, 10 μ F, \pm 20%, 16V
C475	24095887	PF, 0.01 μ F, \pm 3%, 630V
C480	24747220	EL, 22 μ F, \pm 20%, 50V
C481	24503041	PF, 0.1 μ F, 63V
C482	24539474	PF, 0.47 μ F
△C491	24082925	PF, 0.62 μ F, 315V (36AFX61)
△C491	24082923	PF, 0.51 μ F, 315V (32AFX61)
C492	24214121	CD, 120pF, \pm 10%, 500V
C498	24436270	CD, 27pF
C501	24232103	CD, 0.01 μ F, +80%, -20%
C502	24232103	CD, 0.01 μ F, +80%, -20%
C503	24763101	EL, 100 μ F, \pm 20%, 16V
C504	24591222	PF, 2200pF
C505	24353120	CD, 12pF, CH
C508	24794100	EL, 10 μ F, \pm 20%, 16V
C509	24763101	EL, 100 μ F, \pm 20%, 16V
C510	24763101	EL, 100 μ F, \pm 20%, 16V
C511	24232103	CD, 0.01 μ F, +80%, -20%
C512	24206228	EL, 0.22 μ F, \pm 20%, 50V
C513	24232103	CD, 0.01 μ F, +80%, -20%
C514	24503041	PF, 0.1 μ F, 63V
C515	24503041	PF, 0.1 μ F, 63V
C517	24472010	CD, 1pF
C520	24212561	CD, 560pF, \pm 10%
C601	24232103	CD, 0.01 μ F, +80%, -20%
C602	24232103	CD, 0.01 μ F, +80%, -20%
C612	24793221	EL, 220 μ F, \pm 20%, 10V
C621	24206479	EL, 4.7 μ F, \pm 20%, 50V
C622	24206108	EL, 0.1 μ F, \pm 20%, 50V
C623	24591472	PF, 4700pF
C624	24206479	EL, 4.7 μ F, \pm 20%, 50V
C625	24206479	EL, 4.7 μ F, \pm 20%, 50V
C626	24206479	EL, 4.7 μ F, \pm 20%, 50V
C627	24206479	EL, 4.7 μ F, \pm 20%, 50V
C628	24206100	EL, 10 μ F, \pm 20%, 50V
C629	24206100	EL, 10 μ F, \pm 20%, 50V
C630	24206108	EL, 0.1 μ F, \pm 20%, 50V
C631	24591472	PF, 4700pF
C632	24203470	EL, 47 μ F, \pm 20%, 16V
C633	24567224	PF, 0.22 μ F
C634	24206108	EL, 0.1 μ F, \pm 20%, 50V
C635	24203220	EL, 22 μ F, \pm 20%, 16V
C636	24206479	EL, 4.7 μ F, \pm 20%, 50V
C637	24206100	EL, 10 μ F, \pm 20%, 50V
C638	24794101	EL, 100 μ F, \pm 20%, 16V
C639	24232103	CD, 0.01 μ F, +80%, -20%
C640	24591273	PF, 0.027 μ F
C641	24591822	PF, 8200pF
C642	24206100	EL, 10 μ F, \pm 20%, 50V
C643	24206479	EL, 4.7 μ F, \pm 20%, 50V
C644	24206339	EL, 3.3 μ F, \pm 20%, 50V
C645	24591333	PF, 0.033 μ F
C646	24591153	PF, 0.015 μ F
C647	24591683	PF, 0.068 μ F
C648	24591563	PF, 0.056 μ F
C649	24591273	PF, 0.027 μ F

Location No.	Part No.	Description
C650	24591822	PF, 8200pF
C651	24232103	CD, 0.01 μ F, +80%, -20%
C652	24232103	CD, 0.01 μ F, +80%, -20%
C653	24232103	CD, 0.01 μ F, +80%, -20%
C654	24763101	EL, 100 μ F, \pm 20%, 16V
C660	24669229	EL, 2.2 μ F, \pm 20%, 50V
C661	24794100	EL, 10 μ F, \pm 20%, 16V
C664	24797220	EL, 22 μ F, \pm 20%, 50V
C671	24669010	EL, 1 μ F, \pm 20%, 50V
C673	24669479	EL, 4.7 μ F, \pm 20%, 50V
C674	24797010	EL, 1 μ F, \pm 20%, 50V
C675	24667470	EL, 47 μ F, \pm 20%, 25V
C676	24797479	EL, 4.7 μ F, \pm 20%, 50V
C677	24591102	PF, 1000pF
C678	24591102	PF, 1000pF
C679	24591473	PF, 0.047 μ F
C680	24668102	EL, 1000 μ F, \pm 20%, 35V
C681	24668471	EL, 470 μ F, \pm 20%, 35V
C682	24668471	EL, 470 μ F, \pm 20%, 35V
C683	24668102	EL, 1000 μ F, \pm 20%, 35V
C684	24503041	PF, 0.1 μ F, 63V
C685	24503041	PF, 0.1 μ F, 63V
C686	24503041	PF, 0.1 μ F, 63V
C704	24232103	CD, 0.01 μ F, +80%, -20%
C705	24232103	CD, 0.01 μ F, +80%, -20%
C707	24794101	EL, 100 μ F, \pm 20%, 16V
C713	24709100	EL, 10 μ F, \pm 20%, 200V
C714	24436101	CD, 100pF
C715	24214472	CD, 4700pF, \pm 10%, 500V
C716	24436101	CD, 100pF
C717	24214472	CD, 4700pF, \pm 10%, 500V
C718	24794470	EL, 47 μ F, \pm 20%, 16V
C719	24435560	CD, 56pF, 500V
C720	24709100	EL, 10 μ F, \pm 20%, 200V
C721	24794470	EL, 47 μ F, \pm 20%, 16V
C722	24436561	CD, 560pF
C726	24212102	CD, 1000pF, \pm 10%
C801	24095670	PF, 0.22 μ F, \pm 20%, AC125V
C802	24095679	PF, 0.1 μ F, \pm 20%, AC125V
C805	24092623	CD, 0.01 μ F, +80%, -20%, AC250V
C806	24092623	CD, 0.01 μ F, +80%, -20%, AC250V
C810	24086062	EL, 1000 μ F, \pm 20%, 200V
C811	24092585	CD, 4700pF, \pm 20%, AC250V
C812	24092585	CD, 4700pF, \pm 20%, AC250V
C813	24092586	CD, 0.01 μ F, \pm 20%, AC250V
C814	24092586	CD, 0.01 μ F, \pm 20%, AC250V
C831	24794470	EL, 47 μ F, \pm 20%, 16V
C840	24667102	EL, 1000 μ F, \pm 20%, 25V
C842	24792101	EL, 100 μ F, \pm 20%, 6.3V
C843	24503041	PF, 0.1 μ F, 63V
C850	24794470	EL, 47 μ F, \pm 20%, 16V
C860	24214103	CD, 0.01 μ F, \pm 10%, 500V
C861	24212101	CD, 100pF, \pm 10%
C863	24503041	PF, 0.1 μ F, 63V
C864	24092345	CD, 1000pF, \pm 10%, 2kV
C865	24092345	CD, 1000pF, \pm 10%, 2kV
C866	24766478	EL, 0.47 μ F, \pm 20%, 50V
C867	24591103	PF, 0.01 μ F
C868	24667470	EL, 47 μ F, \pm 20%, 25V
C869	24678229	EL, 2.2 μ F, \pm 20%, 200V
C870	24082869	PF, 0.18 μ F, 400V
C871	24092345	CD, 1000pF, \pm 10%, 2kV

Location No.	Part No.	Description
C873	24567224	PF, 0.22 μ F
C874	24435221	CD, 220pF, 500V
C875	24435221	CD, 220pF, 500V
C876	24503041	PF, 0.1 μ F, 63V
C877	24092345	CD, 1000pF, \pm 10%, 2kV
C884	24086049	EL, 330 μ F, \pm 20%, 160V
C885	24214471	CD, 470pF, \pm 10%, 500V
C886	24214471	CD, 470pF, \pm 10%, 500V
C887	24667102	EL, 1000 μ F, \pm 20%, 25V
C889	24668332	EL, 3300 μ F, \pm 20%, 35V
C891	24082229	PF, 0.1 μ F, \pm 10%, 250V
C892	24794100	EL, 10 μ F, \pm 20%, 16V
C893	24092333	CD, 100pF, \pm 10%, 2kV
C894	24092333	CD, 100pF, \pm 10%, 2kV
C896	24214471	CD, 470pF, \pm 10%, 500V
C897	24668332	EL, 3300 μ F, \pm 20%, 35V
C898	24503045	PF, 0.22 μ F, 63V
C899	24214471	CD, 470pF, \pm 10%, 500V
C902	24092353	CD, 4700pF, \pm 10%, 2kV
C904	24436681	CD, 680pF
C905	24436681	CD, 680pF
C907	24436681	CD, 680pF
C909	24679220	EL, 22 μ F, \pm 20%, 250V
C910	24797478	EL, 0.47 μ F, \pm 20%, 50V
C911	24203100	EL, 10 μ F, \pm 20%, 16V
C912	24794471	EL, 470 μ F, \pm 20%, 16V
C913	24794100	EL, 10 μ F, \pm 20%, 16V
C914	24212103	CD, 0.01 μ F, \pm 10%
C920	24232103	CD, 0.01 μ F, +80%, -20%
C921	24232103	CD, 0.01 μ F, +80%, -20%
C930	24214102	CD, 1000pF, \pm 10%, 500V
C970	24794470	EL, 47 μ F, \pm 20%, 16V
C971	24794470	EL, 47 μ F, \pm 20%, 16V
C972	24794470	EL, 47 μ F, \pm 20%, 16V
C3260	24539474	PF, 0.47 μ F
C3440	24082395	PF, 1100pF, \pm 3%, 1250V
CA10	24212101	CD, 100pF, \pm 10%
CA13	24212221	CD, 220pF, \pm 10%
CA19	24666100	EL, 10 μ F, \pm 20%, 16V
CA20	24474181	CD, 180pF, \pm 10%
CA21	24085957	EL, 0.47 μ F, \pm 20%, 40V, Non-Polar
CA22	24232103	CD, 0.01 μ F, +80%, -20%
CA23	24436181	CD, 180pF
CA24	24085957	EL, 0.47 μ F, \pm 20%, 40V, Non-Polar
CA25	24666100	EL, 10 μ F, \pm 20%, 16V
CA26	24085958	EL, 1.0 μ F, \pm 20%, 50V, Non-Polar
CA27	24085958	EL, 1.0 μ F, \pm 20%, 50V, Non-Polar
CA29	24474221	CD, 220pF, \pm 10%
CA30	24474101	CD, 100pF, \pm 10%
CA34	24474101	CD, 100pF, \pm 10%
CA45	24666100	EL, 10 μ F, \pm 20%, 16V
CA49	24666100	EL, 10 μ F, \pm 20%, 16V
CA50	24232103	CD, 0.01 μ F, +80%, -20%
CA52	24591272	PF, 2700pF
CA54	24474101	CD, 100pF, \pm 10%
CA59	24474101	CD, 100pF, \pm 10%
CA60	24474101	CD, 100pF, \pm 10%
CA61	24666220	EL, 22 μ F, \pm 20%, 16V
CA64	24232103	CD, 0.01 μ F, +80%, -20%
CA68	24666100	EL, 10 μ F, \pm 20%, 16V

Location No.	Part No.	Description
CA69	24232103	CD, 0.01 μ F, +80%, -20%
CA71	24474101	CD, 100pF, \pm 10%
CA72	24085970	EL, 10 μ F, \pm 20%, 16V, Non-Polar
CA73	24666100	EL, 10 μ F, \pm 20%, 16V
CB01	24794470	EL, 47 μ F, \pm 20%, 16V
CB13	24085970	EL, 10 μ F, \pm 20%, 16V, Non-Polar
CB14	24474101	CD, 100pF, \pm 10%
CB15	24794100	EL, 10 μ F, \pm 20%, 16V
CB40	24206010	EL, 1 μ F, \pm 20%, 50V
CB41	24591102	PF, 1000pF
CB42	24232103	CD, 0.01 μ F, +80%, -20%
CB43	24591122	PF, 1200pF
CB44	24203100	EL, 10 μ F, \pm 20%, 16V
CB45	24436561	CD, 560pF
CB77	24212271	CD, 270pF, \pm 10%
CB90	24591103	PF, 0.01 μ F
CB91	24794101	EL, 100 μ F, \pm 20%, 16V
CD02	24591562	PF, 5600pF
CD03	24591393	PF, 0.039 μ F
CD04	24591393	PF, 0.039 μ F
CD08	24794100	EL, 10 μ F, \pm 20%, 16V
CD10	24436101	CD, 100pF
CD12	24436101	CD, 100pF
CD13	24797479	EL, 4.7 μ F, \pm 20%, 50V
CD14	24797229	EL, 2.2 μ F, \pm 20%, 50V
CD15	24794470	EL, 47 μ F, \pm 20%, 16V
CD16	24797229	EL, 2.2 μ F, \pm 20%, 50V
CR12	24206108	EL, 0.1 μ F, \pm 20%, 50V
CR13	24206108	EL, 0.1 μ F, \pm 20%, 50V
CR14	24206108	EL, 0.1 μ F, \pm 20%, 50V
CR15	24503041	PF, 0.1 μ F, 63V
CR16	24503041	PF, 0.1 μ F, 63V
CR17	24503041	PF, 0.1 μ F, 63V
CS03	24436221	CD, 220pF
CS04	24206010	EL, 1 μ F, \pm 20%, 50V
CS07	24436221	CD, 220pF
CS08	24206010	EL, 1 μ F, \pm 20%, 50V
CS09	24436331	CD, 330pF
CS10	24206229	EL, 2.2 μ F, \pm 20%, 50V
CS11	24206010	EL, 1 μ F, \pm 20%, 50V
CS12	24436221	CD, 220pF
CS13	24206010	EL, 1 μ F, \pm 20%, 50V
CS14	24436221	CD, 220pF
CS15	24436331	CD, 330pF
CS16	24206229	EL, 2.2 μ F, \pm 20%, 50V
CS21	24436101	CD, 100pF
CS22	24436101	CD, 100pF
CS24	24436331	CD, 330pF
CS25	24206229	EL, 2.2 μ F, \pm 20%, 50V
CS28	24436331	CD, 330pF
CS29	24436331	CD, 330pF
CS32	24203100	EL, 10 μ F, \pm 20%, 16V
CS33	24203100	EL, 10 μ F, \pm 20%, 16V
CS34	24436331	CD, 330pF
CS35	24206229	EL, 2.2 μ F, \pm 20%, 50V
CS36	24206229	EL, 2.2 μ F, \pm 20%, 50V
CS38	24206229	EL, 2.2 μ F, \pm 20%, 50V
CS41	24436331	CD, 330pF
CS42	24206229	EL, 2.2 μ F, \pm 20%, 50V
CS43	24436331	CD, 330pF
CS44	24206229	EL, 2.2 μ F, \pm 20%, 50V
CS115	24206010	EL, 1 μ F, \pm 20%, 50V

Location No.	Part No.	Description
CS116	24206010	EL, 1 μ F, \pm 20%, 50V
CS118	24794470	EL, 47 μ F, \pm 20%, 16V
CS119	24206010	EL, 1 μ F, \pm 20%, 50V
CS120	24232103	CD, 0.01 μ F, +80%, -20%
CS121	24206010	EL, 1 μ F, \pm 20%, 50V
CV01	24085981	EL, 10 μ F, \pm 20%, 16V, Non-Polar
CV02	24232103	CD, 0.01 μ F, +80%, -20%
CV03	24203100	EL, 10 μ F, \pm 20%, 16V
CV04	24203100	EL, 10 μ F, \pm 20%, 16V
CV05	24203100	EL, 10 μ F, \pm 20%, 16V
CV08	24666102	EL, 1000 μ F, \pm 20%, 16V
CV11	24232103	CD, 0.01 μ F, +80%, -20%
CV12	24232103	CD, 0.01 μ F, +80%, -20%
CV16	24085981	EL, 10 μ F, \pm 20%, 16V, Non-Polar
CV17	24203100	EL, 10 μ F, \pm 20%, 16V
CV19	24232103	CD, 0.01 μ F, +80%, -20%
CV21	24203100	EL, 10 μ F, \pm 20%, 16V
CV22	24203100	EL, 10 μ F, \pm 20%, 16V
CV23	24232103	CD, 0.01 μ F, +80%, -20%
CV24	24232103	CD, 0.01 μ F, +80%, -20%
CV31	24203100	EL, 10 μ F, \pm 20%, 16V
CV39	24212102	CD, 1000pF, \pm 10%
CV60	24763101	EL, 100 μ F, \pm 20%, 16V
CV61	24762471	EL, 470 μ F, \pm 20%, 10V
CV62	24232103	CD, 0.01 μ F, +80%, -20%
CV63	24763101	EL, 100 μ F, \pm 20%, 16V
CV64	24232103	CD, 0.01 μ F, +80%, -20%
CV65	24232103	CD, 0.01 μ F, +80%, -20%
CV120	24794100	EL, 10 μ F, \pm 20%, 16V
CW02	24203100	EL, 10 μ F, \pm 20%, 16V
CW03	24203100	EL, 10 μ F, \pm 20%, 16V
CW04	24203100	EL, 10 μ F, \pm 20%, 16V
CW05	24763101	EL, 100 μ F, \pm 20%, 16V
CW06	24232103	CD, 0.01 μ F, +80%, -20%
CW07	24203100	EL, 10 μ F, \pm 20%, 16V
CW08	24763101	EL, 100 μ F, \pm 20%, 16V
CW09	24232103	CD, 0.01 μ F, +80%, -20%
CY80	24203100	EL, 10 μ F, \pm 20%, 16V
RESISTORS		
R101	24382183	OMF, 18k ohm, 1W
R150	24366101	CF, 100 ohm
R151	24366562	CF, 5600 ohm
R152	24366103	CF, 10k ohm
R201	24366821	CF, 820 ohm
R202	24366102	CF, 1k ohm
R204	24366104	CF, 100k ohm
R205	24366101	CF, 100 ohm
R206	24366102	CF, 1k ohm
R207	24366101	CF, 100 ohm
R208	24366101	CF, 100 ohm
R209	24366101	CF, 100 ohm
R212	24366472	CF, 4700 ohm
R213	24366122	CF, 1200 ohm
R214	24366222	CF, 2200 ohm
R216	24366103	CF, 10k ohm
R217	24366102	CF, 1k ohm
R218	24367103	CF, 10k ohm, \pm 2%
R223	24366102	CF, 1k ohm
R227	24367472	CF, 4700 ohm, \pm 2%
R260	24366153	CF, 15k ohm
R261	24366682	CF, 6800 ohm

Location No.	Part No.	Description
R266	24366102	CF, 1k ohm
R267	24366102	CF, 1k ohm
R268	24366681	CF, 680 ohm
R269	24366102	CF, 1k ohm
R270	24366682	CF, 6800 ohm
R303	24321109	MF, 1 ohm, 1/2W
R305	24322688	MF, 0.68 ohm, 1W
R306	24366333	CF, 33k ohm
R309	24366154	CF, 150k ohm
R310	24366102	CF, 1k ohm
R312	24366103	CF, 10k ohm (36AFX61)
R313	24366153	CF, 15k ohm
R317	24366472	CF, 4700 ohm
R318	24366101	CF, 100 ohm
R319	24366101	CF, 100 ohm
R320	24366101	CF, 100 ohm
R322	24366394	CF, 390k ohm
R323	24366274	CF, 270k ohm
R324	24366224	CF, 220k ohm (36AFX61)
R324	24366334	CF, 330k ohm (32AFX61)
R326	24366104	CF, 100k ohm (32AFX61)
R327	24339189	MF, 1.8 ohm, 2W
R328	24366202	CF, 2k ohm
R329	24366153	CF, 15k ohm
R330	24366102	CF, 1k ohm
R331	24366184	CF, 180k ohm (36AFX61)
R331	24366224	CF, 220k ohm (32AFX61)
R336	24383151	OMF, 150 ohm, 2W
R353	24366621	CF, 620 ohm
R360	24366223	CF, 22k ohm
R361	24366102	CF, 1k ohm
R361	24366223	CF, 22k ohm
R362	24366103	CF, 10k ohm
R362	24366223	CF, 22k ohm
R362	24366103	CF, 10k ohm
R363	24366103	CF, 10k ohm
R363	24366472	CF, 4700 ohm
R364	24366332	CF, 3300 ohm
R365	24366681	CF, 680 ohm
R366	24366431	CF, 430 ohm
R367	24366472	CF, 4700 ohm
R368	24366333	CF, 33k ohm
R369	24366433	CF, 43k ohm
R370	24321109	MF, 1 ohm, 1/2W
R371	24366103	CF, 10k ohm
R372	24366222	CF, 2200 ohm
R373	24366102	CF, 1k ohm
R374	24366163	CF, 16k ohm
R379	24382103	OMF, 10k ohm, 1W
R380	24946226	CC, 22M ohm, \pm 10%, 1/2W
R389	24366472	CF, 4700 ohm
R392	24552102	OMF, 1k ohm, 1/2W
R394	24366102	CF, 1k ohm
R396	24366103	CF, 10k ohm
R397	24366103	CF, 10k ohm
R398	24366184	CF, 180k ohm
R399	24366103	CF, 10k ohm
R400	24946561	CC, 560 ohm, 1/2W
R401	24366391	CF, 390 ohm
R402	24366103	CF, 10k ohm
R403	24366302	CF, 3k ohm
R405	24553682	OMF, 6800 ohm, 1W
R407	24366103	CF, 10k ohm
R410	24366331	CF, 330 ohm
R411	24366331	CF, 330 ohm

Location No.	Part No.	Description
R413	24366102	CF, 1k ohm
R415	24553272	OMF, 2700 ohm, 1W
R416	24510562	Cement, 5600 ohm, 5W
R424	24545278	FR, 0.27 ohm, 1/4W
R425	24552332	OMF, 3300 ohm, 1/2W
R426	24366821	CF, 820 ohm
R427	24366392	CF, 3900 ohm
R428	24366561	CF, 560 ohm
R429	24552560	OMF, 56 ohm, 1/2W
R431	24366103	CF, 10k ohm
R432	24531560	FR, 56 ohm, 1/2W
R433	24366472	CF, 4700 ohm
R434	24366202	CF, 2k ohm
R441	24532102	FR, 1k ohm, 1W
R442	24382513	OMF, 51k ohm, 1W
R445	24310229	MF, 2.2 ohm, 1/2W
△ R451	24327133	MF, 13k ohm, ±1%, 1/4W
R452	24366333	CF, 33k ohm
△ R453	24327472	MF, 4700 ohm, ±1%, 1/4W
R458	24327183	MF, 18k ohm, ±1%, 1/4W
R463	24322479	MF, 4.7 ohm, 1W
R470	24338568	MF, 0.56 ohm, 1W
R471	24553301	OMF, 300 ohm, 1W
R472	24553270	OMF, 27 ohm, 1W
△ R475	24366471	CF, 470 ohm
R476	24366823	CF, 82k ohm
R477	24366273	CF, 27k ohm
R478	24376333	CF, 33k ohm, 1/2W
R479	24553131	OMF, 130 ohm, 1W
R481	24366223	CF, 22k ohm
R482	24366223	CF, 22k ohm
R487	24366154	CF, 150k ohm
R488	24366563	CF, 56k ohm
R489	24327183	MF, 18k ohm, ±1%, 1/4W
R490	24366102	CF, 1k ohm
R493	24366102	CF, 1k ohm
R494	24366471	CF, 470 ohm
R495	24366561	CF, 560 ohm
R498	24510279	Cement, 2.7 ohm, 5W
R501	24366223	CF, 22k ohm
R502	24366101	CF, 100 ohm
R503	24366101	CF, 100 ohm
R504	24366101	CF, 100 ohm
R505	24366102	CF, 1k ohm
R506	24366103	CF, 10k ohm
R508	24366102	CF, 1k ohm
R509	24366102	CF, 1k ohm
R510	24366102	CF, 1k ohm
R511	24366101	CF, 100 ohm
R512	24366101	CF, 100 ohm
R514	24366122	CF, 1200 ohm
R515	24366103	CF, 10k ohm
R612	24366103	CF, 10k ohm
R613	24366222	CF, 2200 ohm
R621	24366101	CF, 100 ohm
R622	24366105	CF, 1M ohm
R623	24366101	CF, 100 ohm
R624	24366101	CF, 100 ohm
R625	24366101	CF, 100 ohm
R626	24366101	CF, 100 ohm
R627	24366101	CF, 100 ohm
R633	24366101	CF, 100 ohm
R634	24366101	CF, 100 ohm
R635	24366101	CF, 100 ohm

Location No.	Part No.	Description
R636	24366101	CF, 100 ohm
R637	24366101	CF, 100 ohm
R638	24366101	CF, 100 ohm
R639	24366101	CF, 100 ohm
R640	24366101	CF, 100 ohm
R641	24366101	CF, 100 ohm
R642	24366101	CF, 100 ohm
R643	24366101	CF, 100 ohm
R668	24366122	CF, 1200 ohm
R669	24366153	CF, 15k ohm
R670	24366103	CF, 10k ohm
R671	24366272	CF, 2700 ohm
R672	24366103	CF, 10k ohm
R673	24366272	CF, 2700 ohm
R675	24366103	CF, 10k ohm
R676	24366223	CF, 22k ohm
R677	24366223	CF, 22k ohm
R680	24366473	CF, 47k ohm
R682	24366104	CF, 100k ohm
R683	24366333	CF, 33k ohm
R684	24366229	CF, 2.2 ohm
R685	24366229	CF, 2.2 ohm
R686	24366229	CF, 2.2 ohm
R702	24366681	CF, 680 ohm
R709	24366563	CF, 56k ohm
R713	24366393	CF, 39k ohm
R714	24552121	OMF, 120 ohm, 1/2W
R715	24366273	CF, 27k ohm
R716	24366333	CF, 33k ohm
R717	24366333	CF, 33k ohm
R718	24366101	CF, 100 ohm
R719	24366392	CF, 3900 ohm
R720	24366392	CF, 3900 ohm
R722	24366102	CF, 1k ohm
R723	24366471	CF, 470 ohm
R724	24366820	CF, 82 ohm
R725	24366182	CF, 1800 ohm
R730	24552100	OMF, 10 ohm, 1/2W
R731	24552331	OMF, 330 ohm, 1/2W
R732	24366820	CF, 82 ohm
R733	24366683	CF, 68k ohm
R734	24366820	CF, 82 ohm
R735	24366683	CF, 68k ohm
R736	24366620	CF, 62 ohm
R737	24366152	CF, 1500 ohm
R738	24366102	CF, 1k ohm
R739	24366152	CF, 1500 ohm
R740	24366620	CF, 62 ohm
R741	24366279	CF, 2.7 ohm
R742	24366279	CF, 2.7 ohm
R743	24554221	OMF, 220 ohm, 2W
R744	24366122	CF, 1200 ohm
R745	24366122	CF, 1200 ohm
R802	24942105	CC, 1M ohm, 1/2W
R808	24019477	PTC Thermistor, 1.5 ohm, AC140V
R810	24007874	Cement, 1 ohm, 15W
R831	24366821	CF, 820 ohm
R832	24548399	FR, 3.9 ohm, 2W
R850	24322759	MF, 7.5 ohm, 1W
R851	24366561	CF, 560 ohm
R861	24382223	OMF, 22k ohm, 1W
R862	24552330	OMF, 33 ohm, 1/2W
R864	24552102	OMF, 1k ohm, 1/2W

Location No.	Part No.	Description
R865	24552221	OMF, 220 ohm, 1/2W
R867	24366223	CF, 22k ohm
R868	24552560	OMF, 56 ohm, 1/2W
R870	24381181	OMF, 180 ohm, 1/2W
R871	24381151	OMF, 150 ohm, 1/2W
R872	24382563	OMF, 56k ohm, 1W
R883	24381682	OMF, 6800 ohm, 1/2W
R884	24366102	CF, 1k ohm
R891	24366102	CF, 1k ohm
R898	24002000	CC, 3.9M ohm, $\pm 10\%$, 1/2W
R901	24376561	CF, 560 ohm, 1/2W
R902	24376561	CF, 560 ohm, 1/2W
R903	24376561	CF, 560 ohm, 1/2W
R904	24366103	CF, 10k ohm
R905	24366101	CF, 100 ohm
R912	24366102	CF, 1k ohm
R914	24366561	CF, 560 ohm
R915	24366101	CF, 100 ohm
R916	24366470	CF, 47 ohm
R917	24366471	CF, 470 ohm
R918	24366820	CF, 82 ohm
R919	24366102	CF, 1k ohm
R920	24000883	FR, 3.6 ohm, 1W (36AFX61)
R920	24000568	FR, 4.7 ohm, 1W (32AFX61)
R921	24366561	CF, 560 ohm
R922	24366101	CF, 100 ohm
R923	24366391	CF, 390 ohm
R924	24366820	CF, 82 ohm
R925	24366471	CF, 470 ohm
R926	24366102	CF, 1k ohm
R928	24366561	CF, 560 ohm
R929	24366101	CF, 100 ohm
R930	24366820	CF, 82 ohm
R932	24366272	CF, 2700 ohm
R933	24366750	CF, 75 ohm
R934	24366391	CF, 390 ohm
R935	24366821	CF, 820 ohm
R936	24366750	CF, 75 ohm
R937	24366471	CF, 470 ohm
R939	24366101	CF, 100 ohm
R940	24366821	CF, 820 ohm
R942	24366392	CF, 3900 ohm
R943	24366392	CF, 3900 ohm
R944	24366392	CF, 3900 ohm
R945	24366470	CF, 47 ohm
R946	24366470	CF, 47 ohm
R947	24366103	CF, 10k ohm
R948	24366103	CF, 10k ohm
R949	24366103	CF, 10k ohm
R950	24366302	CF, 3k ohm
R951	24366682	CF, 6800 ohm
R952	24366101	CF, 100 ohm
R955	24366122	CF, 1200 ohm
R957	24366822	CF, 8200 ohm
R960	24383153	OMF, 15k ohm, 2W
R961	24383153	OMF, 15k ohm, 2W
R962	24383153	OMF, 15k ohm, 2W
R963	24383153	OMF, 15k ohm, 2W
R964	24383153	OMF, 15k ohm, 2W
R965	24383153	OMF, 15k ohm, 2W
R973	24366472	CF, 4700 ohm
R976	24366102	CF, 1k ohm
R977	24366122	CF, 1200 ohm
R978	24366102	CF, 1k ohm

Location No.	Part No.	Description
R979	24366102	CF, 1k ohm
R980	24366471	CF, 470 ohm
R981	24366821	CF, 820 ohm
R982	24366103	CF, 10k ohm
R983	24366222	CF, 2200 ohm
R984	24367152	CF, 1500 ohm, $\pm 2\%$
R985	24367471	CF, 470 ohm, $\pm 2\%$
R986	24367681	CF, 680 ohm, $\pm 2\%$
R987	24367681	CF, 680 ohm, $\pm 2\%$
R988	24367472	CF, 4700 ohm, $\pm 2\%$
R989	24367332	CF, 3300 ohm, $\pm 2\%$
R990	24366222	CF, 2200 ohm
R991	24367681	CF, 680 ohm, $\pm 2\%$
R992	24366150	CF, 15 ohm
R993	24366471	CF, 470 ohm
R994	24366392	CF, 3900 ohm
R997	24366272	CF, 2700 ohm
R998	24366472	CF, 4700 ohm
R999	24366472	CF, 4700 ohm
R3326	24366563	CF, 56k ohm (36AFX61)
R3440	24338129	MF, 1.2 ohm, 1W
R3442	24005016	Metal-Glazed Resistor, 180k ohm, 1/2W
R3443	24005016	Metal-Glazed Resistor, 180k ohm, 1/2W
R3444	24005016	Metal-Glazed Resistor, 180k ohm, 1/2W
R3445	24005016	Metal-Glazed Resistor, 180k ohm, 1/2W
R4310	24366183	CF, 18k ohm
R4311	24366563	CF, 56k ohm
R4385	24366822	CF, 8200 ohm
R4386	24366331	CF, 330 ohm
R4460	24366102	CF, 1k ohm
R4461	24366102	CF, 1k ohm
R4462	24366133	CF, 13k ohm
R4463	24366682	CF, 6800 ohm
R4761	24366102	CF, 1k ohm
R4762	24366332	CF, 3300 ohm (36AFX61)
R4762	24366104	CF, 100k ohm (32AFX61)
R4763	24366472	CF, 4700 ohm (36AFX61)
R4763	24366103	CF, 10k ohm (32AFX61)
R4764	24366104	CF, 100k ohm (32AFX61)
R4765	24366221	CF, 220 ohm
R4766	24366102	CF, 1k ohm (36AFX61)
R4766	24366202	CF, 2k ohm (32AFX61)
R4767	24003984	MF, 1000 ohm, 1/4W (32AFX61)
R4768	24366392	CF, 3900 ohm (36AFX61)
R4768	24366622	CF, 6200 ohm (32AFX61)
R4769	24366102	CF, 1k ohm (32AFX61)
R4771	24366103	CF, 10k ohm (36AFX61)
R4772	24366224	CF, 220k ohm (36AFX61)
RA01	24366102	CF, 1k ohm
RA02	24366101	CF, 100 ohm
RA03	24366101	CF, 100 ohm
RA04	24366102	CF, 1k ohm
RA05	24366102	CF, 1k ohm
RA06	24366102	CF, 1k ohm
RA07	24366102	CF, 1k ohm
RA09	24366102	CF, 1k ohm
RA10	24366102	CF, 1k ohm
RA11	24366102	CF, 1k ohm
RA12	24366102	CF, 1k ohm

Location No.	Part No.	Description
RA13	24366102	CF, 1k ohm
RA15	24366102	CF, 1k ohm
RA16	24366102	CF, 1k ohm
RA17	24366102	CF, 1k ohm
RA18	24366102	CF, 1k ohm
RA19	24366102	CF, 1k ohm
RA26	24366101	CF, 100 ohm
RA27	24366101	CF, 100 ohm
RA28	24366102	CF, 1k ohm
RA29	24366102	CF, 1k ohm
RA30	24366102	CF, 1k ohm
RA31	24366102	CF, 1k ohm
RA33	24366102	CF, 1k ohm
RA34	24366102	CF, 1k ohm
RA35	24366102	CF, 1k ohm
RA39	24366102	CF, 1k ohm
RA46	24366332	CF, 3300 ohm
RA47	24366182	CF, 1800 ohm
RA48	24366101	CF, 100 ohm
RA49	24366332	CF, 3300 ohm
RA50	24366682	CF, 6800 ohm
RA51	24366151	CF, 150 ohm
RA52	24366103	CF, 10k ohm
RA54	24366332	CF, 3300 ohm
RA55	24366102	CF, 1k ohm
RA56	24366102	CF, 1k ohm
RA59	24366101	CF, 100 ohm
RA60	24366101	CF, 100 ohm
RA71	24366683	CF, 68k ohm
RA72	24366223	CF, 22k ohm
RA73	24366103	CF, 10k ohm
RA74	24366153	CF, 15k ohm
RA75	24366153	CF, 15k ohm
RA76	24366822	CF, 8200 ohm
RA77	24366153	CF, 15k ohm
RA78	24366273	CF, 27k ohm
RA79	24366333	CF, 33k ohm
RA80	24366101	CF, 100 ohm
RA82	24366332	CF, 3300 ohm
RA83	24366332	CF, 3300 ohm
RA86	24366103	CF, 10k ohm
RA87	24366103	CF, 10k ohm
RA88	24366333	CF, 33k ohm
RB03	24366101	CF, 100 ohm
RB11	24366271	CF, 270 ohm
RB12	24366103	CF, 10k ohm
RB13	24366470	CF, 47 ohm
RB14	24366153	CF, 15k ohm
RB15	24366153	CF, 15k ohm
RB16	24366332	CF, 3300 ohm
RB17	24366332	CF, 3300 ohm
RB30	24366103	CF, 10k ohm
RB31	24366472	CF, 4700 ohm
RB32	24366274	CF, 270k ohm
RB33	24366123	CF, 12k ohm
RB34	24366392	CF, 3900 ohm
RB35	24366103	CF, 10k ohm
RB37	24366302	CF, 3k ohm
RB38	24366103	CF, 10k ohm
RB39	24366123	CF, 12k ohm
RB40	24366681	CF, 680 ohm
RB41	24366273	CF, 27k ohm
RB42	24366273	CF, 27k ohm
RB46	24366103	CF, 10k ohm

Location No.	Part No.	Description
RB49	24366331	CF, 330 ohm
RB75	24366472	CF, 4700 ohm
RB76	24366103	CF, 10k ohm
RB77	24366222	CF, 2200 ohm
RB78	24366101	CF, 100 ohm
RB81	24366122	CF, 1200 ohm
RB82	24366123	CF, 12k ohm
RB83	24366123	CF, 12k ohm
RB84	24366562	CF, 5600 ohm
RB90	24366392	CF, 3900 ohm
RB91	24366473	CF, 47k ohm
RB92	24366271	CF, 270 ohm
RB93	24366271	CF, 270 ohm
RB94	24366222	CF, 2200 ohm
RB95	24366222	CF, 2200 ohm
RB96	24366273	CF, 27k ohm
RB97	24366273	CF, 27k ohm
RB98	24366102	CF, 1k ohm
RD09	24366101	CF, 100 ohm
RD11	24366101	CF, 100 ohm
RD13	24366222	CF, 2200 ohm
RD14	24366103	CF, 10k ohm
RD16	24366103	CF, 10k ohm
RJ01	24366103	CF, 10k ohm
RJ02	24366102	CF, 1k ohm
RJ04	24366102	CF, 1k ohm
RJ05	24323479	MF, 4.7 ohm, 2W
RJ06	24366103	CF, 10k ohm
RM16	24366101	CF, 100 ohm
RM18	24366102	CF, 1k ohm
RR08	24366101	CF, 100 ohm
RR09	24366222	CF, 2200 ohm
RR10	24366102	CF, 1k ohm
RR12	24366151	CF, 150 ohm
RR13	24366151	CF, 150 ohm
RR14	24366151	CF, 150 ohm
RR15	24366151	CF, 150 ohm
RR16	24366151	CF, 150 ohm
RR17	24366151	CF, 150 ohm
RR18	24366222	CF, 2200 ohm
RR40	24366101	CF, 100 ohm
RR42	24366101	CF, 100 ohm
RR44	24366101	CF, 100 ohm
RS02	24366472	CF, 4700 ohm
RS04	24366102	CF, 1k ohm
RS06	24366102	CF, 1k ohm
RS07	24366103	CF, 10k ohm
RS08	24366103	CF, 10k ohm
RS09	24366102	CF, 1k ohm
RS10	24366102	CF, 1k ohm
RS12	24366103	CF, 10k ohm
RS21	24366104	CF, 100k ohm
RS22	24366104	CF, 100k ohm
RS25	24366223	CF, 22k ohm
RS26	24366223	CF, 22k ohm
RS27	24366471	CF, 470 ohm
RS28	24366471	CF, 470 ohm
RS29	24366104	CF, 100k ohm
RS30	24366104	CF, 100k ohm
RS31	24366103	CF, 10k ohm
RS33	24366222	CF, 2200 ohm
RS34	24366222	CF, 2200 ohm
RS35	24366103	CF, 10k ohm
RS36	24366103	CF, 10k ohm

Location No.	Part No.	Description
RS37	24366101	CF, 100 ohm
RS40	24366101	CF, 100 ohm
RS42	24366101	CF, 100 ohm
RS48	24366101	CF, 100 ohm
RS49	24366103	CF, 10k ohm
RS51	24366103	CF, 10k ohm
RS52	24366103	CF, 10k ohm
RS101	24366123	CF, 12k ohm
RS102	24366123	CF, 12k ohm
RS103	24366103	CF, 10k ohm
RS104	24366104	CF, 100k ohm
RS105	24366332	CF, 3300 ohm
RS107	24366473	CF, 47k ohm
RS108	24366473	CF, 47k ohm
RS109	24366153	CF, 15k ohm
RS110	24366101	CF, 100 ohm
RS111	24366222	CF, 2200 ohm
RS112	24366223	CF, 22k ohm
RS113	24366153	CF, 15k ohm
RS114	24366101	CF, 100 ohm
RS115	24366222	CF, 2200 ohm
RS116	24366223	CF, 22k ohm
RV01	24366750	CF, 75 ohm
RV03	24366750	CF, 75 ohm
RV04	24366101	CF, 100 ohm
RV07	24366750	CF, 75 ohm
RV09	24366750	CF, 75 ohm
RV10	24366100	CF, 10 ohm
RV11	24366100	CF, 10 ohm
RV12	24366100	CF, 10 ohm
RV13	24366750	CF, 75 ohm
RV14	24366750	CF, 75 ohm
RV15	24366750	CF, 75 ohm
RV17	24366750	CF, 75 ohm
RV18	24366750	CF, 75 ohm
RV19	24366332	CF, 3300 ohm
RV20	24366472	CF, 4700 ohm
RV21	24366101	CF, 100 ohm
RV22	24366100	CF, 10 ohm
RV23	24366100	CF, 10 ohm
RV24	24366222	CF, 2200 ohm
RV28	24366472	CF, 4700 ohm
RV31	24366332	CF, 3300 ohm
RV32	24366750	CF, 75 ohm
RV62	24366101	CF, 100 ohm
RV63	24552221	OMF, 220 ohm, 1/2W
RV64	24366750	CF, 75 ohm
RV83	24366332	CF, 3300 ohm
RV84	24366750	CF, 75 ohm
RV120	24366750	CF, 75 ohm
RW01	24366683	CF, 68k ohm
RW02	24366473	CF, 47k ohm
RW03	24366333	CF, 33k ohm
RW04	24366223	CF, 22k ohm
RW05	24366102	CF, 1k ohm
RW06	24366101	CF, 100 ohm
RW07	24366222	CF, 2200 ohm
RW08	24366101	CF, 100 ohm
RW10	24366102	CF, 1k ohm
RW14	24366101	CF, 100 ohm
RW16	24366101	CF, 100 ohm
RW18	24366103	CF, 10k ohm
RW19	24366473	CF, 47k ohm
RW20	24366101	CF, 100 ohm

Location No.	Part No.	Description
RW24	24366471	CF, 470 ohm
RW26	24366682	CF, 6800 ohm
RW27	24366682	CF, 6800 ohm
RW28	24366751	CF, 750 ohm
RW29	24366102	CF, 1k ohm
RW30	24366102	CF, 1k ohm
RW39	24366472	CF, 4700 ohm
RW40	24366222	CF, 2200 ohm
RY80	24366331	CF, 330 ohm
RY81	24366101	CF, 100 ohm
RY82	24366102	CF, 1k ohm
RY83	24366100	CF, 10 ohm
RZ30	24366102	CF, 1k ohm
COILS & TRANSFORMERS		
L101	23289680	Coil, Peaking, TRF4680AF
L111	23289680	Coil, Peaking, TRF4680AF
L113	23289220	Coil, Peaking, TRF4220AF
L115	23103824	Coil, TEM2028K
L121	23238562	Coil, Peaking, TRF4109AJ
L122	23238562	Coil, Peaking, TRF4109AJ
L301	23103859	Coil (Ferrite Bead), TEM2011
L302	23237975	Coil, Peaking, TRF4101AC
L400	23289840	Coil, Peaking, TRF4100AT
△L441	23233036	Coil, Linearity, TLN2083AT
L442	23248121	Coil, Choke, TLN3383D (36AX61)
L442	23248122	Coil, Choke, TLN3384D (32AFX61)
L447	23248286	Coil, Choke, TLN3516AH (32AX61)
△L461	23248179	Coil, Choke, TLN3339AD
L463	23103859	Coil (Ferrite Bead), TEM2011
L491	23228785	Transformer, TPC1016AH
L501	23289844	Coil, Peaking, TRF4470AT
L502	23289844	Coil, Peaking, TRF4470AT
L503	23289470	Coil, Peaking, TRF4470AF
L702	23261974	Coil, Choke, HC5-035
L704	23103859	Coil (Ferrite Bead), TEM2011
L705	23103859	Coil (Ferrite Bead), TEM2011
L805	23248227	Coil, Choke, TLN3481AD
L806	23248227	Coil, Choke, TLN3481AD
L861	23103880	Coil (Ferrite Bead), TEM2011Y
L862	23103880	Coil (Ferrite Bead), TEM2011Y
L883	23103880	Coil (Ferrite Bead), TEM2011Y
L884	23103880	Coil (Ferrite Bead), TEM2011Y
L885	23248073	Coil, Choke, TLN3299D
L886	23103880	Coil (Ferrite Bead), TEM2011Y
L887	23103880	Coil (Ferrite Bead), TEM2011Y
L888	23248087	Coil, Choke, TLN3312D
L889	23248087	Coil, Choke, TLN3312D
L893	23103880	Coil (Ferrite Bead), TEM2011Y
L894	23103880	Coil (Ferrite Bead), TEM2011Y
L901	23200447	Coil, Degaussing, TSB-2407AK (36AFX61)
L901	23200454	Coil, Degaussing, TSB-2412AK (32AFX61)
L902	23289101	Coil, Peaking, TRF4101AF
L903	23289101	Coil, Peaking, TRF4101AF
L904	23289101	Coil, Peaking, TRF4101AF
L905	23289390	Coil, Peaking, TRF4390AF
L906	23289390	Coil, Peaking, TRF4390AF
L907	23289390	Coil, Peaking, TRF4390AF
L908	23289100	Coil, Peaking, TRF4100AF

Location No.	Part No.	Description
L910	23237991	Coil, Peaking, TRF4479AC
LA22	23289840	Coil, Peaking, TRF4100AT
LA49	23289840	Coil, Peaking, TRF4100AT
LJ901	23200465	Coil, Degaussing, TSB-2411AG
LV05	23289560	Coil, Peaking, TRF4560AF
LV06	23289560	Coil, Peaking, TRF4560AF
LV19	23289560	Coil, Peaking, TRF4560AF
LV27	23103824	Coil, TEM2028K
LV28	23103824	Coil, TEM2028K
LV60	23289840	Coil, Peaking, TRF4100AT
LV61	23289840	Coil, Peaking, TRF4100AT
LW03	23103845	Coil, TEM2030AY
LW07	23289842	Coil, Peaking, TRF4220AT
LY80	23103824	Coil, TEM2028K
LZ20	23238562	Coil, Peaking, TRF4109AJ
LZ21	23238562	Coil, Peaking, TRF4109AJ
T400	23224364	Transformer, Focus, TLN2168AH
T401	23224367	Transformer, Horiz. Drive, TLN1098AH
△T461	23236672	Transformer, Flyback, TFB4172AD (36AFX61)
△T461	23236718	Transformer, Flyback, TFB4166BH (32AFX61)
T801	23211729	Line Filter, TRF3232AQ
T840	23217233	Transformer, Converter, TPW1547AZ
T862	23217486	Transformer, Converter, TPW3463AS

SEMICONDUCTORS

Q151	23114530	Transistor, 2SA933S-Q
Q152	23114528	Transistor, 2SC1740S, Q
Q201	23114528	Transistor, 2SC1740S, Q
Q202	23114528	Transistor, 2SC1740S, Q
Q203	23114437	Transistor, 2SC752GTM-Y
Q261	23114528	Transistor, 2SC1740S, Q
Q262	23114530	Transistor, 2SA933S-Q
Q263	23114530	Transistor, 2SA933S-Q
Q301	23905610	IC, LA7846N
Q302	23905871	IC, TA1241AN
Q306	23114530	Transistor, 2SA933S-Q
Q307	23114528	Transistor, 2SC1740S, Q
Q308	23114528	Transistor, 2SC1740S, Q
Q360	23114528	Transistor, 2SC1740S, Q
Q390	23318187	IC, TA75558S
Q391	23314548	Transistor, 2SC4256
Q402	23114755	Transistor, 2SC2482(FA-1,C)
Q404	23314955	Transistor, 2SD2553(FA)
Q420	23314141	Transistor, 2SC3852
Q421	23114433	Transistor, 2SC1815-Y
Q430	23314445	Transistor, 2SC4721, Q
Q460	23314938	Transistor, 2SD2493(P)
Q462	23114530	Transistor, 2SA933S-Q (32AFX61)
Q465	23114530	Transistor, 2SA933S-Q
Q470	23114528	Transistor, 2SC1740S, Q
Q471	23114426	Transistor, 2SA1015-O(TEM)
Q472	23114433	Transistor, 2SC1815-Y
Q480	23114759	Transistor, 2SA949-Y(C) (36AFX61)
Q480	23114425	Transistor, 2SA1015-Y(TEM) (32AFX61)
Q481	23114433	Transistor, 2SC1815-Y

Location No.	Part No.	Description
Q482	23114433	Transistor, 2SC1815-Y
Q483	23114469	Transistor, RN2201
Q501	23905575	IC, TA1222BN
Q502	23114528	Transistor, 2SC1740S, Q
Q503	23114528	Transistor, 2SC1740S, Q
Q610	23906523	IC, TA8256BH
Q612	23314962	Transistor, KTA1266 Y
Q621	23000381	IC, CXA2021S
Q622	23000548	IC, TA1304N
Q670	23114623	Transistor, 2SC2878-A(TEM)
Q671	23114623	Transistor, 2SC2878-A(TEM)
Q672	23114623	Transistor, 2SC2878-A(TEM)
Q706	23114528	Transistor, 2SC1740S, Q
Q707	23114528	Transistor, 2SC1740S, Q
Q709	23114528	Transistor, 2SC1740S, Q
Q710	23114530	Transistor, 2SA933S-Q
Q711	23314909	Transistor, 2SA1837
Q712	23314912	Transistor, 2SC4793
Q719	23114528	Transistor, 2SC1740S, Q
Q720	23114528	Transistor, 2SC1740S, Q
Q801	23135017	IC, STR-Z4316
Q805	23114459	Transistor, RN1205
Q830	23314141	Transistor, 2SC3852
Q840	23318299	IC, L78MR05
Q843	23114459	Transistor, RN1205
Q850	23314707	Transistor, 2SD1944, H
Q862	23000823	IC, TLP421F(GR)
△Q883	23319692	IC, SE130N, LF4
Q901	23314780	Transistor, 2SC4544
Q902	23114433	Transistor, 2SC1815-Y
Q903	23314780	Transistor, 2SC4544
Q904	23114433	Transistor, 2SC1815-Y
Q905	23314780	Transistor, 2SC4544
Q906	23114433	Transistor, 2SC1815-Y
Q907	23114530	Transistor, 2SA933S-Q
Q908	23114429	Transistor, 2SC2120-Y(TEM)
Q910	23114528	Transistor, 2SC1740S, Q
Q911	23114528	Transistor, 2SC1740S, Q
Q912	23114530	Transistor, 2SA933S-Q
Q913	23114530	Transistor, 2SA933S-Q
Q914	23114528	Transistor, 2SC1740S, Q
Q920	23114528	Transistor, 2SC1740S, Q
Q921	23114528	Transistor, 2SC1740S, Q
Q922	23114528	Transistor, 2SC1740S, Q
Q923	23114528	Transistor, 2SC1740S, Q
Q924	23114528	Transistor, 2SC1740S, Q
Q925	23114528	Transistor, 2SC1740S, Q
Q4460	23114528	Transistor, 2SC1740S, Q
Q4461	23114528	Transistor, 2SC1740S, Q
QA01	23000566	IC, MN102L35GFG
QA02	23905321	IC, 24LC16B-I/P
QA71	23114530	Transistor, 2SA933S-Q
QB03	23114459	Transistor, RN1205
QB11	23114528	Transistor, 2SC1740S, Q
QB14	23114530	Transistor, 2SA933S-Q
QB30	23114528	Transistor, 2SC1740S, Q
QB41	23114530	Transistor, 2SA933S-Q
QB42	23114530	Transistor, 2SA933S-Q
QB43	23114528	Transistor, 2SC1740S, Q
QB44	23114460	Transistor, RN1204
QB77	23114528	Transistor, 2SC1740S, Q
QB81	23114623	Transistor, 2SC2878-A(TEM)
QB82	23114623	Transistor, 2SC2878-A(TEM)
QB83	23114530	Transistor, 2SA933S-Q

Location No.	Part No.	Description
QB84	23114528	Transistor, 2SC1740S, Q
QB85	23114530	Transistor, 2SA933S-Q
QB86	23114530	Transistor, 2SA933S-Q
QB87	23114530	Transistor, 2SA933S-Q
QB88	23114530	Transistor, 2SA933S-Q
QD01	23905002	IC, TA8173AP
QJ02	23114528	Transistor, 2SC1740S, Q
QJ03	23314912	Transistor, 2SC4793
QJ04	23114528	Transistor, 2SC1740S, Q
QM03	23114528	Transistor, 2SC1740S, Q
QR02	23114528	Transistor, 2SC1740S, Q
QS01	23114623	Transistor, 2SC2878-A(TEM)
QS101	23904303	IC, BA10358
QS102	23114466	Transistor, RN2204
QS103	23114623	Transistor, 2SC2878-A(TEM)
QS104	23114623	Transistor, 2SC2878-A(TEM)
QS11	23114623	Transistor, 2SC2878-A(TEM)
QS12	23114466	Transistor, RN2204
QS13	23314965	Transistor, KTC3198 Y
QS14	23314965	Transistor, KTC3198 Y
QV01	23905539	IC, TA8851CN
QV60	23114528	Transistor, 2SC1740S, Q
QW01	23000043	IC, TC4053BP(N)
QW02	23114528	Transistor, 2SC1740S, Q
QW03	23114528	Transistor, 2SC1740S, Q
QW04	23114528	Transistor, 2SC1740S, Q
QW05	23114528	Transistor, 2SC1740S, Q
QW10	23114530	Transistor, 2SA933S-Q
QW11	23114528	Transistor, 2SC1740S, Q
QW16	23114530	Transistor, 2SA933S-Q
QW17	23114463	Transistor, RN1201
QW18	23114530	Transistor, 2SA933S-Q
QY80	23114528	Transistor, 2SC1740S, Q
QZ11	23114528	Transistor, 2SC1740S, Q
D101	23316756	Diode, Zener, MTZJ33D
D201	23118859	Diode, 1SS133
D215	23118859	Diode, 1SS133
D216	23118859	Diode, 1SS133
D217	23118859	Diode, 1SS133
D218	23118859	Diode, 1SS133
D219	23118859	Diode, 1SS133
D220	23118859	Diode, 1SS133
D301	23118479	Diode, BYD33J
D302	23118094	Diode, EU2A, LF-F10
D303	23316794	Diode, SC570A
D311	23118859	Diode, 1SS133 (36AFX61)
D335	23316715	Diode, Zener, MTZJ11A
D336	23316672	Diode, Zener, MTZJ5.6B
D337	23118529	Diode, Zener, RD5.6ESA B2
D338	23316655	Diode, Zener, MTZJ3.0B
D370	23316672	Diode, Zener, MTZJ5.6B
D371	23118859	Diode, 1SS133
D390	23316651	Diode, Zener, MTZJ2.4B
D395	23316725	Diode, Zener, MTZJ15B
D401	23316719	Diode, Zener, MTZJ12B
D404	23316254	Diode, ERC06-15L
D406	23115910	Diode, S5295G
D420	23316680	Diode, Zener, MTZJ7.5A
D430	23316689	Diode, Zener, MTZJ10A
D441	23316687	Diode, Zener, MTZJ9.1B
D442	23118094	Diode, EU2A, LF-F10
D444	23316969	Diode, ERD29-06J
D467	23115296	Diode, 1S1887(FA)
D470	23118859	Diode, 1SS133

Location No.	Part No.	Description
D471	23115820	Diode, TVR-1B
△D472	23115774	Diode, Zener, RD6.2E(4)
D473	23118859	Diode, 1SS133
D474	23316719	Diode, Zener, MTZJ12B
D477	23118859	Diode, 1SS133 (36AFX61)
D480	23316757	Diode, Zener, MTZJ36A
D490	23316718	Diode, Zener, MTZJ12A
D512	23118859	Diode, 1SS133
D611	23118859	Diode, 1SS133
D612	23118859	Diode, 1SS133
D613	23118859	Diode, 1SS133
D614	23118859	Diode, 1SS133
D622	23316719	Diode, Zener, MTZJ12B
D622	23357113	Diode, Zener, HZS12N B2
D670	23118859	Diode, 1SS133
D671	23118859	Diode, 1SS133
D674	23118859	Diode, 1SS133
D675	23118859	Diode, 1SS133
D704	23118859	Diode, 1SS133
D705	23118859	Diode, 1SS133
D715	23118859	Diode, 1SS133
D720	23118859	Diode, 1SS133
D721	23118859	Diode, 1SS133
D801	23357041	Diode, LN6SB60-F05
D830	23316673	Diode, Zener, MTZJ5.6C
D840	23316962	Diode, S1WBA20 4101
D845	23118859	Diode, 1SS133
D850	23316673	Diode, Zener, MTZJ5.6C
D855	23118859	Diode, 1SS133
D862	23118094	Diode, EU2A, LF-F10
D864	23118094	Diode, EU2A, LF-F10
D873	23316719	Diode, Zener, MTZJ12B
D875	23316719	Diode, Zener, MTZJ12B
D876	23316747	Diode, Zener, MTZJ27C
D881	23118859	Diode, 1SS133
△D882	23316679	Diode, Zener, MTZJ6.8C
D883	23357018	Diode, RL2, LF-C1
D884	23357018	Diode, RL2, LF-C1
D885	23316819	Diode, RU4YX, LF015
D886	23316819	Diode, RU4YX, LF015
D891	23316819	Diode, RU4YX, LF015
D892	23316819	Diode, RU4YX, LF015
D899	24019486	Varistor, ENE431D-10S
D901	23118859	Diode, 1SS133
D903	23118859	Diode, 1SS133
D904	23118859	Diode, 1SS133
D905	23118859	Diode, 1SS133
D906	23118859	Diode, 1SS133
D907	23118859	Diode, 1SS133
D908	23118859	Diode, 1SS133
D909	23118859	Diode, 1SS133
D910	23118859	Diode, 1SS133
D911	23115337	Diode, 1S1834
D3440	23115999	Diode, 1S1832
D3441	23115999	Diode, 1S1832
D4385	23316680	Diode, Zener, MTZJ7.5A
D4386	23118859	Diode, 1SS133
DA02	23316674	Diode, Zener, MTZJ6.2A
DA11	23118859	Diode, 1SS133
DA34	23118859	Diode, 1SS133
DA43	23118859	Diode, 1SS133
DA44	23118859	Diode, 1SS133
DA45	23118859	Diode, 1SS133
DA46	23118859	Diode, 1SS133

Location No.	Part No.	Description
DB01	23358564	Diode (LED), SLR-56VC3FPQ
DB03	23358522	Diode (LED), SIR-56SB3F
DB05	23316675	Diode, Zener, MTZJ6.2B
DB30	23118859	Diode, 1SS133
DB40	23118859	Diode, 1SS133
DJ01	23118859	Diode, 1SS133
DJ02	23316726	Diode, Zener, MTZJ15C
DR84	23118859	Diode, 1SS133
DS106	23316660	Diode, Zener, MTZJ3.9A
DV01	23118518	Diode, Zener, RD9.1ESA B1
DV02	23316686	Diode, Zener, MTZJ9.1A
DV03	23316686	Diode, Zener, MTZJ9.1A
DV07	23316686	Diode, Zener, MTZJ9.1A
DV08	23316686	Diode, Zener, MTZJ9.1A
DV09	23316686	Diode, Zener, MTZJ9.1A
DV11	23316686	Diode, Zener, MTZJ9.1A
DV12	23316686	Diode, Zener, MTZJ9.1A
DV13	23316686	Diode, Zener, MTZJ9.1A
DV17	23316686	Diode, Zener, MTZJ9.1A
MISCELLANEOUS		
F470	23144897	Fuse, 2.0A, 125V
F801	23144745	Fuse, 10.0A, 125V
F860	23144456	Fuse, 5.0A, 125V
F890	23144735	Fuse, 5.0A-T, 125V, Mini
F899	23144735	Fuse, 5.0A-T, 125V, Mini
G101	24366101	CF, 100 ohm
G102	24366101	CF, 100 ohm
G302	24366472	CF, 4700 ohm
G306	24366222	CF, 2200 ohm
G312	24503039	PF, 0.068 μ F, 63V (36AFX61)
G403	24946223	CC, 22k ohm, \pm 10%, 1/2W
G501	24366101	CF, 100 ohm
G840	24366680	CF, 68 ohm
G897	23280016	Coil, Peaking, TRF4100AZ
H003	23344421	RF Switch, RSU133X6
KB01	23906805	Remote Sensor, PIC-TB17
S602	23145412	Switch, Slide, 2C2P
SA01	23145227	Switch, Push, 1C1P
SA02	23145227	Switch, Push, 1C1P
SA03	23145227	Switch, Push, 1C1P
SA04	23145227	Switch, Push, 1C1P
SA05	23145227	Switch, Push, 1C1P
SA06	23145227	Switch, Push, 1C1P
SA07	23145227	Switch, Push, 1C1P
SA08	23145227	Switch, Push, 1C1P
SJ01	23146958	Relay, DC12V
SR81	23146556	Relay, DC12V
SR83	23146570	Relay, DC12V
UZ01	23148747	Module, MYCJ32, 3D-YCS COMB
V901A	23903145	Socket, CRT
W661	23351038	Speaker, SPK-1311, 60x120mm, 8 ohm
W662	23351038	Speaker, SPK-1311, 60x120mm, 8 ohm
W665	23351133	Speaker, SPK-1392, 100X100mm, 16 ohm
X401	23153721	Ceramic Resonator, 503kHz, TCR1023
X501	23153961	Crystal, 3.58MHz
XA01	23153011	Ceramic Resonator, 4.00MHz, TCR1050
Z401	23140203	SG-GAP, SG99B3EN

Location No.	Part No.	Description
ZY01	23148736	Module, MKMU31, MULTI PICTURE PNT
PC BOARD ASSEMBLIES		
* U801	23786256	POWER/DEF Board, PB9631E (36AFX61)
* U801	23786690	POWER/DEF Board, PB9631F (32AFX61)
* U901	23786258	CRT/D-VM Board, PB9973E2 (36AFX61)
* U901	23786691	CRT/D-VM Board, PB9973G2 (32AFX61)
* U902	23786257	Signal Board, PB9635E
* UA01	23786698	PW Board, PB9570A (36AFX61)
* UA01	23785396	PW Board, PB9699 (32AFX61)
* UA02	23786348	CONT-2 Board, PB9571C2 (36AFX61)
* UA02	23785391	CONT-2 Board, PB9700 (32AFX61)
* UV01	23785234	BACK AV Board, PB9633A
PICTURE TUBE		
△ V901	23312922	Picture Tube, A90AJZ90X01 (36AFX61)
△ V901	23312930	Picture Tube, A80ERF031X13 (32AFX61)
TUNER		
H001	23321411	Tuner, EL967LW
HY01	23321412	Tuner, EL963L
ACCESSORIES		
K912	23306370	Remote Hand Unit, CT-90047
K912A	23101988	Battery, LR6G R SP-2A
Y101	23565239	Owner's Manual, English, 36AFX61/32AFX61
Y101F	23565240	Owner's Manual, French, 36AFX61/32AFX61
CABINET PARTS		
A201	23540691	Front Cover (36AFX61)
A201	23540704	Front Cover (32AFX61)
A212	23450397	Control Panel
A213	23427977	Door
A214	23451976	Push, Catch
A224	23445521	Button
A226	23450398	Panel (36AFX61)
A226	23450399	Panel (32AFX61)
A401	23007664	Back Cover (36AFX61)
A401	23007137	Back Cover (32AFX61)
A701	23946097	Carton (36AFX61)
A701	23064254	Carton (32AFX61)
A703	23946094	Packing, Top (36AFX61)
A703	23946056	Packing, Top (32AFX61)

**THIS PAGE IS
INTENTIONALLY LEFT
BLANK.**

SIGNAL BOARD PB9635
BOTTOM (FOIL) SIDE

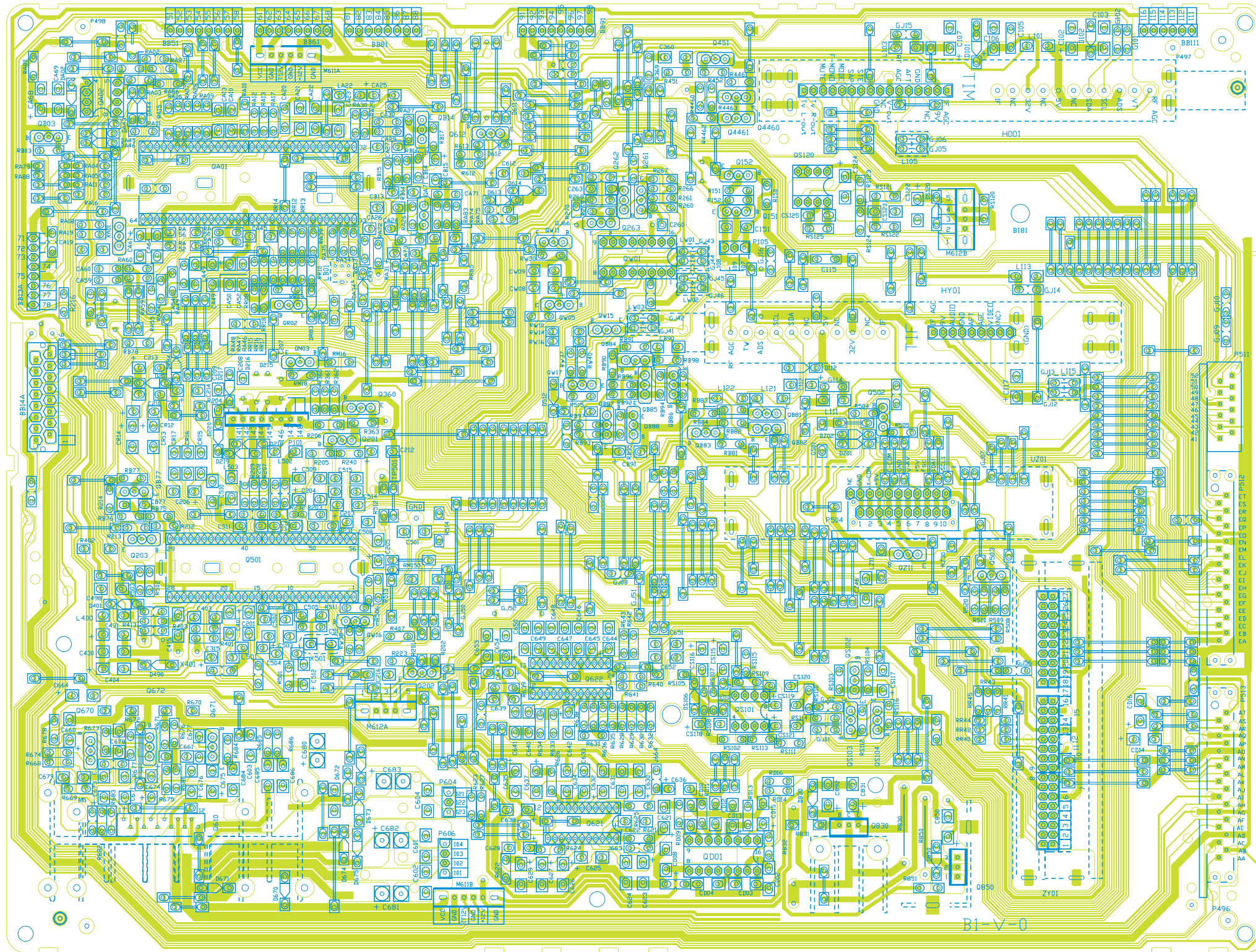

POWER/DEF BOARD PB9631
BOTTOM (FOIL) SIDE

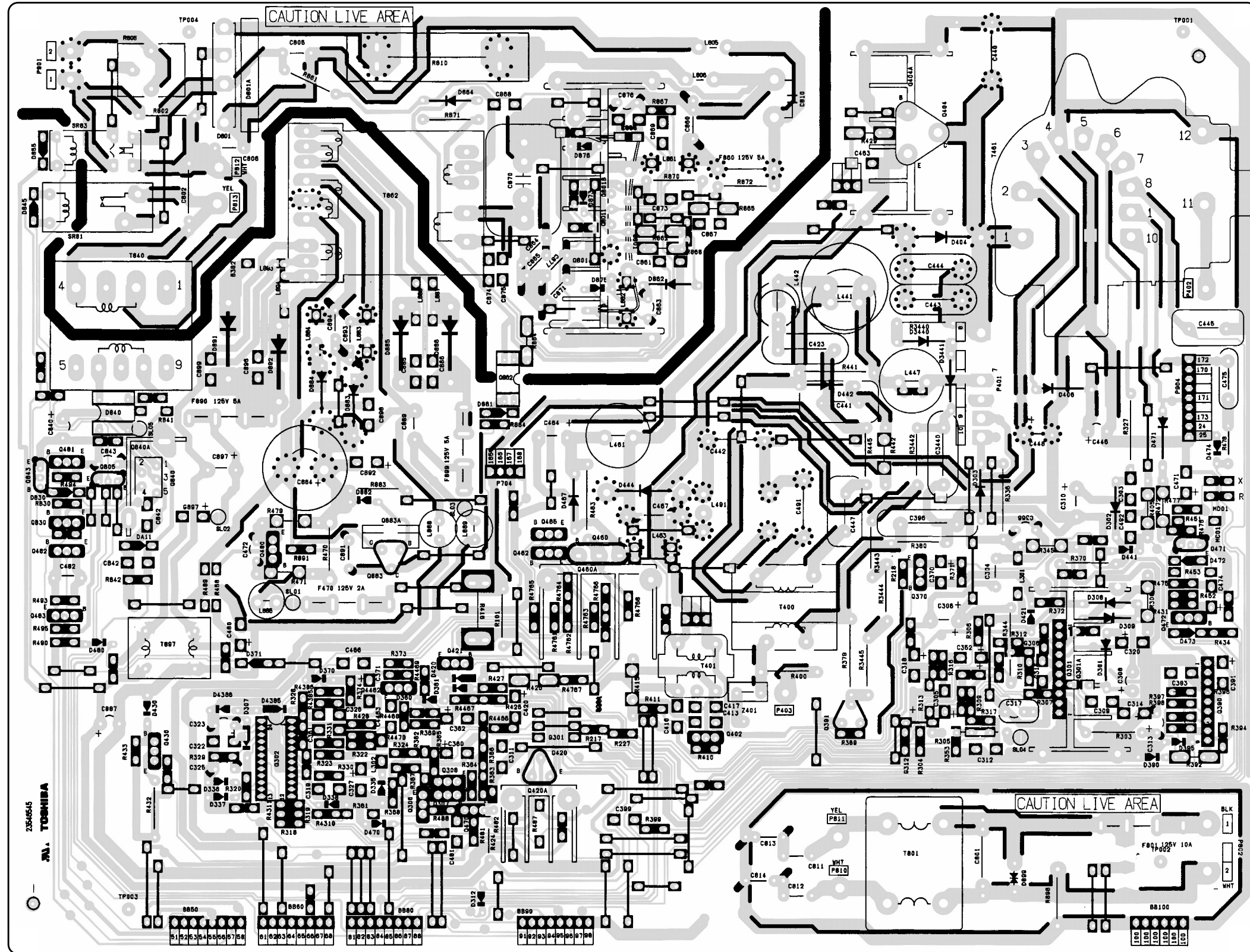

CRT DRIVE BOARD PB9973

BOTTOM (FOIL) SIDE

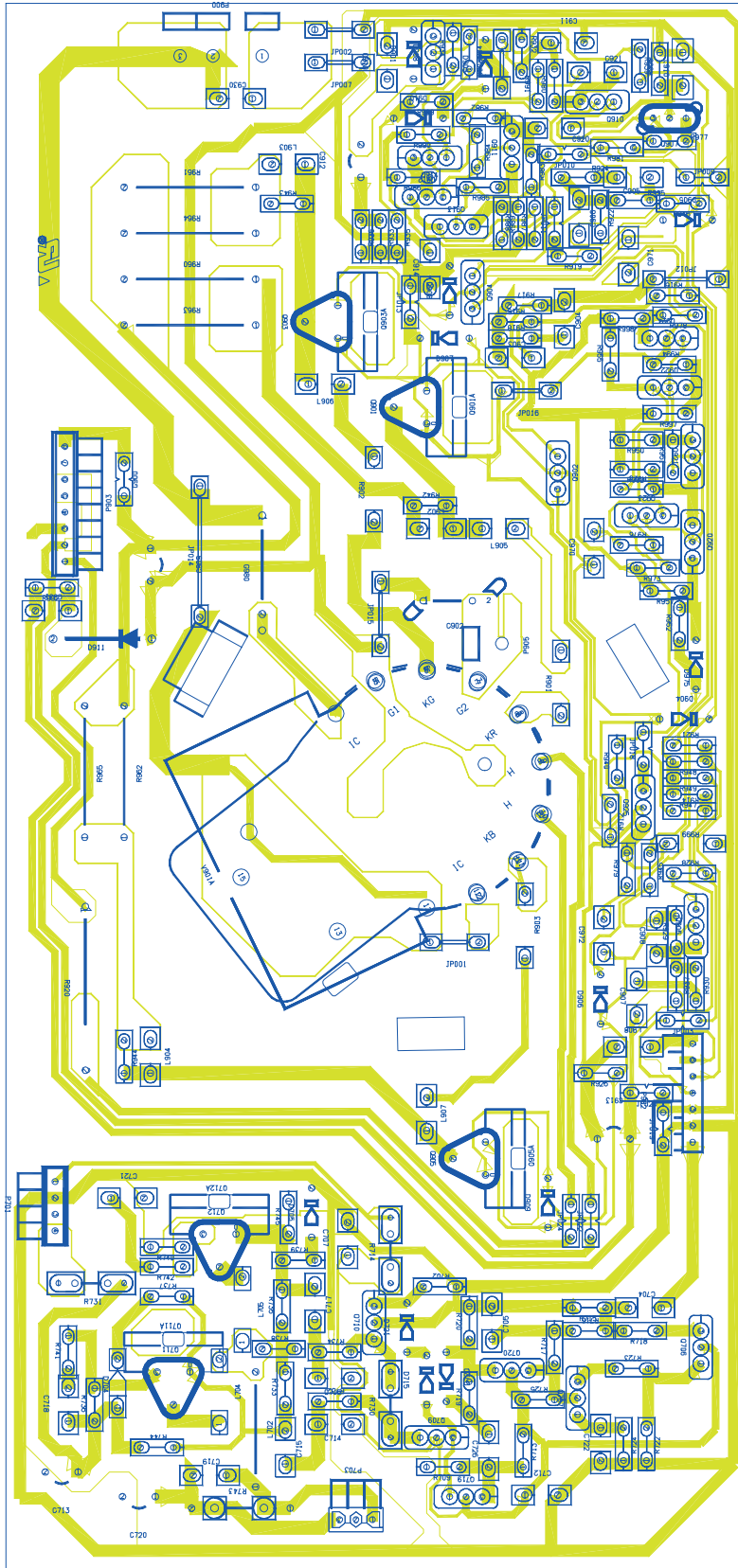

BACK A/V BOARD PB9633

BOTTOM (FOIL) SIDE

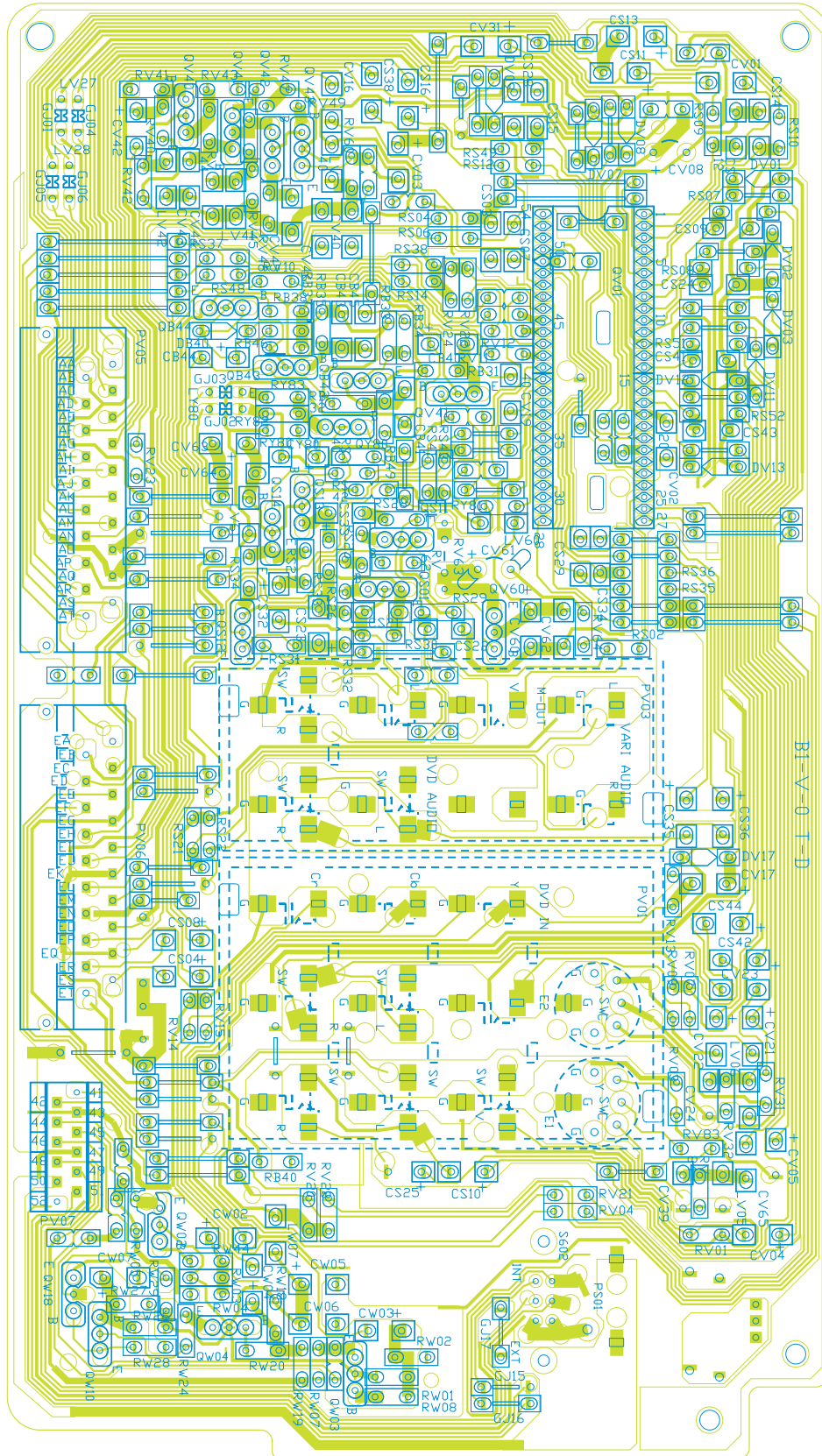

CONTROL-1 BOARD PB9570

BOTTOM (FOIL) SIDE

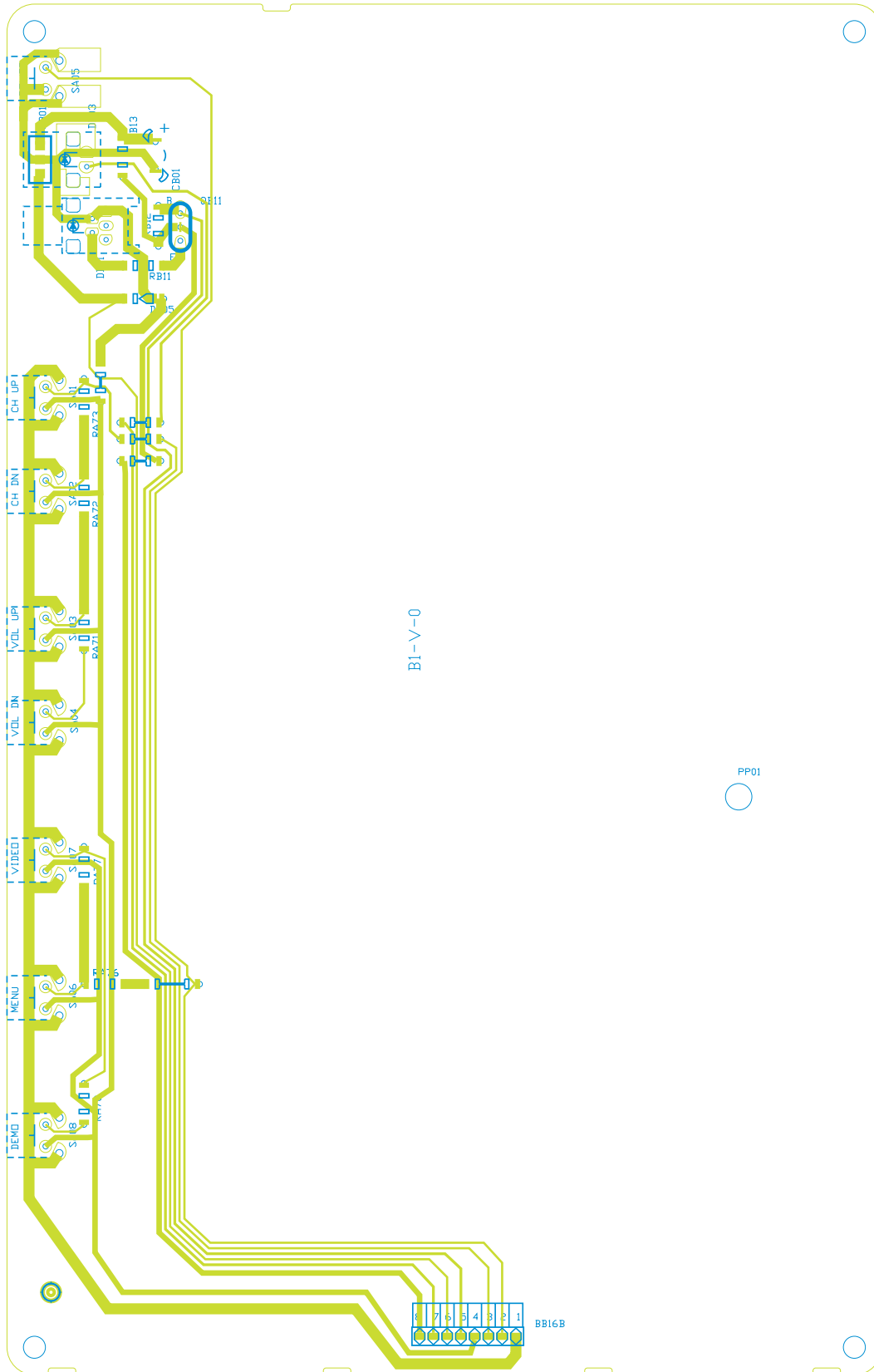

CONTROL-2 BOARD PB9571

BOTTOM (FOIL) SIDE

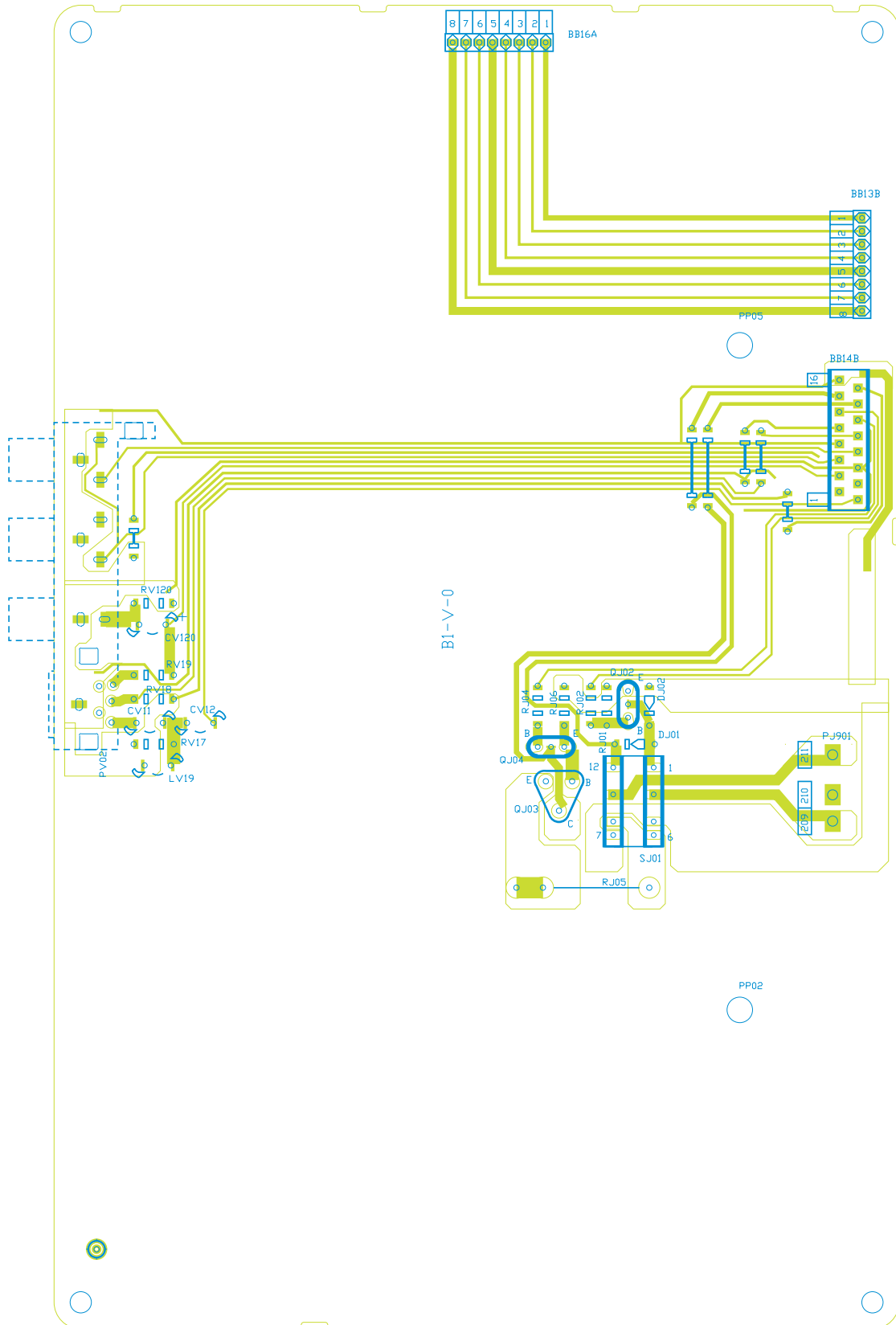

TERMINAL VIEW OF TRANSISTORS

- ① 2SD2253
(old)
2SC5243

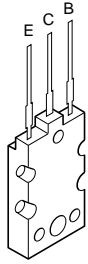

- ② 2SC3852
2SD1763A
2SC1569
2SC4544
2SA1788
2SA1306
2SA1186A

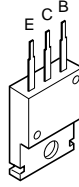

- ③ 2SC752GTM
2SC2482
2SC2655
2SC4721P

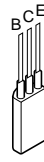

- ④ 2SC752
2SA562TM
2SA1015
2SC1815
2SC2878
2SC1740S
2SC2120
2SA9335



- ⑤ 2SA1788

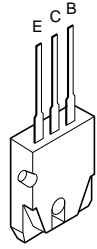

- ⑥ RN2203
RN2201
RN2004
RN1203
RN1204
RN2204
RN1205
RN1202
RN1201

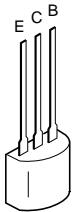

- ⑦ 2SD1554
2SD2253
2SD1556
2SC5143
2SC5570
2SD2553

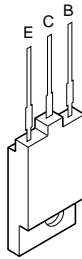

- ⑧ ON4409

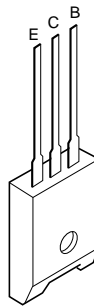

SPECIFICATIONS (Representative: 36AFX61)	
TELEVISION SYSTEM	NTSC standard
CHANNEL COVERAGE	VHF: 2 through 13 UHF: 14 through 69 Cable TV: mid band (A-8 through A-1, A through I) super band (J through W) hyper band (AA through ZZ, AAA, BBB) ultra band (65 through 94, 100 through 125)
POWER SOURCE	120V AC, 60Hz
POWER CONSUMPTION	176 W (average)
AUDIO POWER	10W + 10W, 13 W (Sub-woofer)
SPEAKER TYPE	Two 2-3/8 x 4-3/4 inches (60 x 120mm), one 4 inches (10cm)
VIDEO/AUDIO TERMINALS	S-VIDEO INPUT Y: 1V(p-p), 75 ohm, negative sync. C: 0.286V(p-p) (burst signal), 75 ohm VIDEO/AUDIO INPUT VIDEO: 1V(p-p), 75 ohm, negative sync. AUDIO: 150mV(rms) (30% modulation equivalent, 47k ohm) ColorStream™ (Component video) INPUT Y: 1V (p-p), 75 ohm C _B : 0.7 V (p-p), 75 ohm C _R : 0.7 V (p-p), 75 ohm AUDIO: 150 mV (rms) 47k ohm VIDEO/AUDIO OUT PUT VIDEO: 1 V (p-p), 75 ohm, negative sync. AUDIO: 150 mV (rms) (30% modulation equivalent, 4.7k ohm) VARIABLE AUDIO OUTPUT 0-300mV(rms) (30% modulation equivalent, 4.7k ohm) AUDIO CENTER CHANNEL INPUT 300mV(rms) (30% modulation equivalent, 10k ohm)
DIMENSIONS	Width 38-1/4 inches (972 mm) Height 29-5/8 inches (753 mm) Depth 24-1/4 inches (615 mm)
MASS	211.6 lbs (96.0 kg)
SUPPLIED ACCESORIES	Remote Control with 2 "AA" size alkaline batteries

* Please refer to owner's manual in detail.

TOSHIBA CORPORATION
1-1, SHIBAURA 1-CHOME, MINATO-KU, TOKYO 105-8001, JAPAN