



T&S BRASS AND BRONZE WORKS, INC.

2 Saddleback Cove / P.O. Box 1088
Travelers Rest, SC 29690

Model No.

B-1335

Item No.

Travelers Rest, SC: 800-476-4103 • Simi Valley, CA: 800-423-0150 • Fax: 864-834-3518 • www.tsbrass.com

This Space for Architect/Engineer Approval

Job Name _____ Date _____

Model Specified _____ Quantity _____

Customer/Wholesaler _____

Contractor _____

Architect/Engineer _____

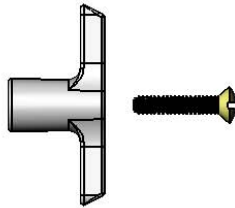

T-Handle Kit w/ Mounting Screw
for Supply Stop

Loose Key
Style Shut-Off
Valve

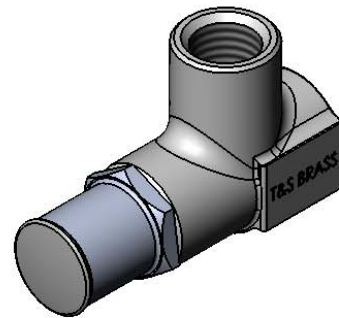

3/8" NPT
Female Outlet

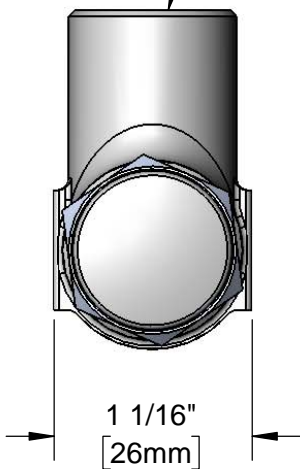

2 3/4"
[70mm]

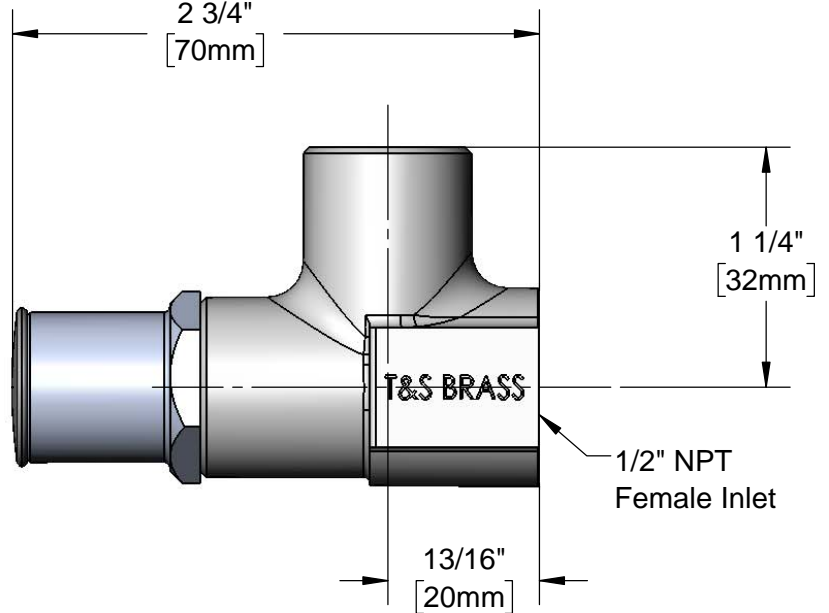

Product Specifications:

Loose Key Angle Stop w/ Loose Key Handle, 1/2" NPT Female Inlet and 3/8" NPT Female Outlet

Product Compliance:

ASME A112.18.1 / CSA B125.1
NSF 61 - Section 9
NSF 372 (Low Lead Content)



T&S BRASS AND BRONZE WORKS, INC.
2 Saddleback Cove / P.O. Box 1088
Travelers Rest, SC 29690

Model No.
B-1335

Item No.

Travelers Rest, SC: 800-476-4103 • Simi Valley, CA: 800-423-0150 • Fax: 864-834-3518 • www.tsbrass.com

ITEM NO.	SALES NO.	DESCRIPTION
1	000763-20	Seat
2	002892-40	Spindle Asm w/ Cap
3	001605-45	Cap
4	001802-45	Handle, Supply Stop "T"
5	002432-45	Screw, Tee Handle

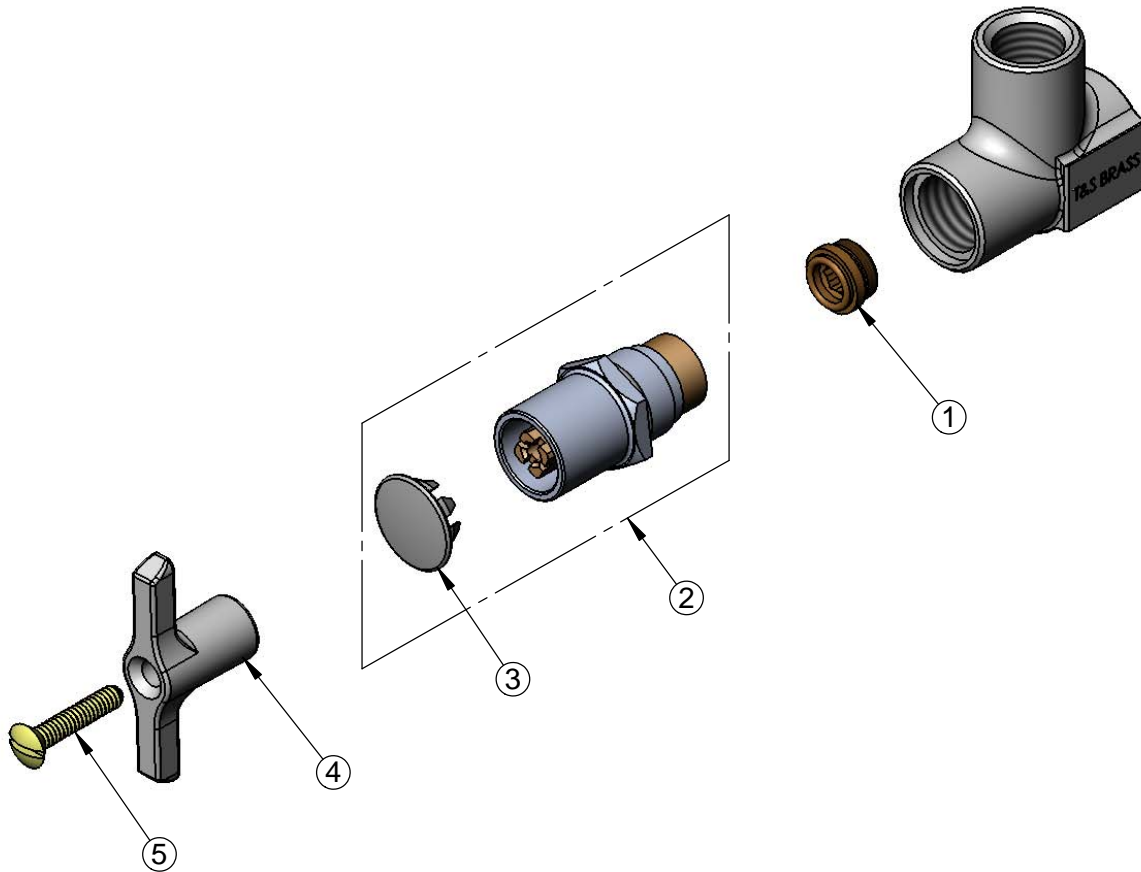

Product Specifications:
Loose Key Angle Stop w/ Loose Key Handle, 1/2" NPT Female Inlet and 3/8" NPT Female Outlet

Product Compliance:
ASME A112.18.1 / CSA B125.1
NSF 61 - Section 9
NSF 372 (Low Lead Content)