



T&S BRASS AND BRONZE WORKS, INC.
 2 Saddleback Cove / P.O. Box 1088
 Travelers Rest, SC 29690

Model No.
B-0508

Item No.

Travelers Rest, SC: 800-476-4103 • Simi Valley, CA: 800-423-0150 • Fax: 864-834-3518 • www.tsbrass.com

This Space for Architect/Engineer Approval

Job Name _____ Date _____

Model Specified _____ Quantity _____

Customer/Wholesaler _____

Contractor _____

Architect/Engineer _____

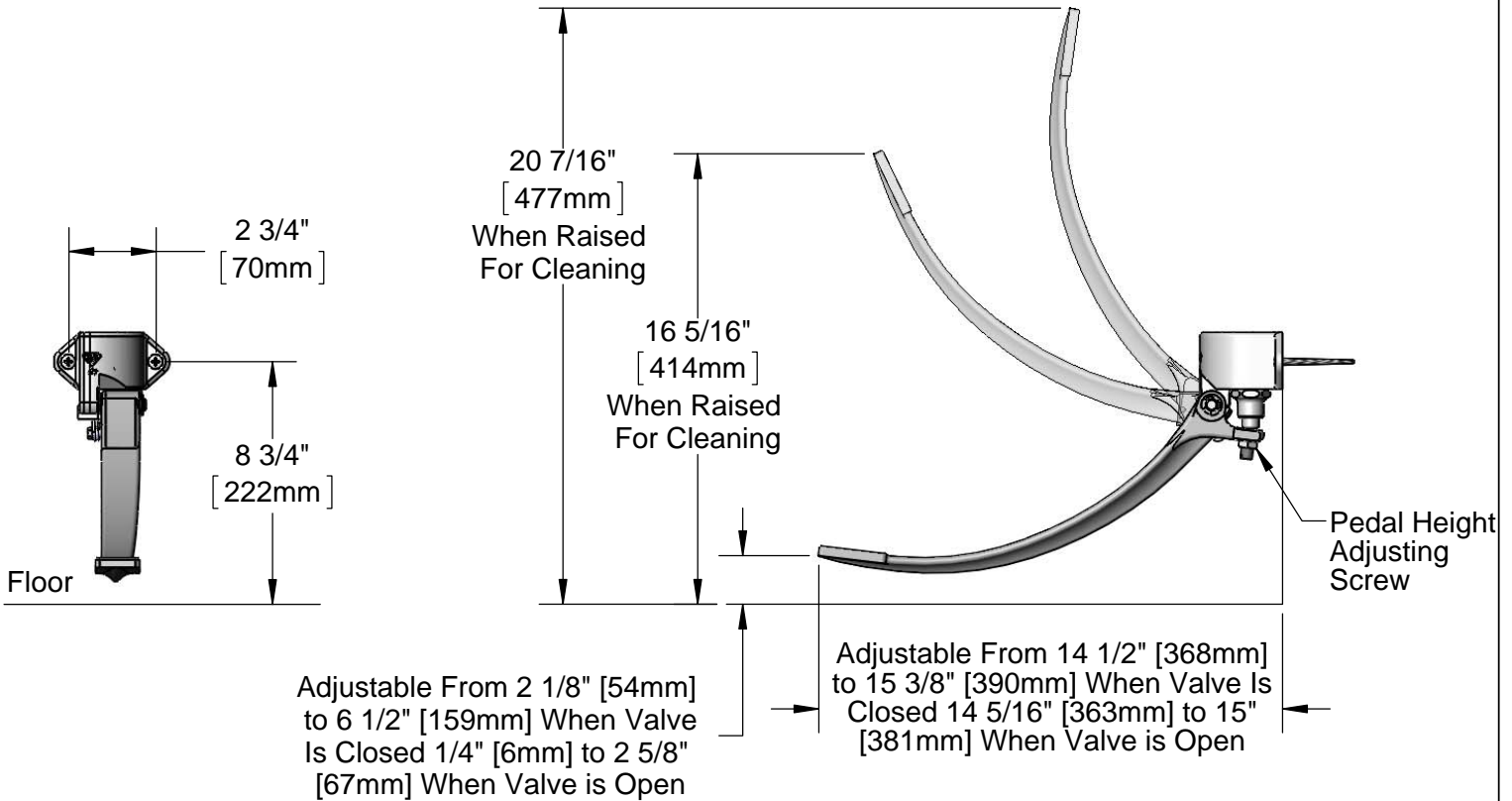
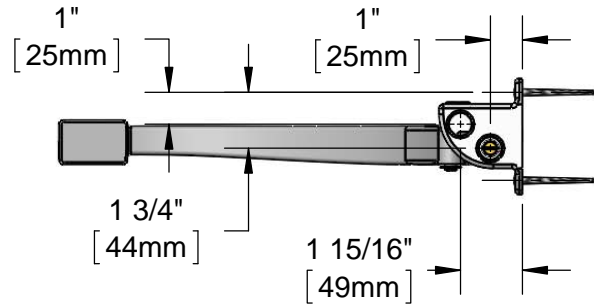
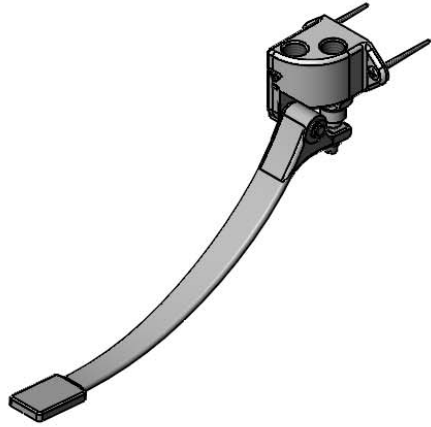

Product Specifications:
 Single Wall Mount Pedal Valve w/ Volume Control & 1/2" NPT
 Female Inlet and Outlet

Product Compliance:
 ASME A112.18.1 / CSA B125.1
 NSF 61 - Section 9
 NSF 372 (Low Lead Content)



T&S BRASS AND BRONZE WORKS, INC.
 2 Saddleback Cove / P.O. Box 1088
 Travelers Rest, SC 29690

Model No.
B-0508

Item No.

Travelers Rest, SC: 800-476-4103 • Simi Valley, CA: 800-423-0150 • Fax: 864-834-3518 • www.tsbrass.com

ITEM NO.	SALES NO.	DESCRIPTION
1	003749-45	Foot Pedal Mtg. Screw
2	012513-10	Pad
3	012523-45	Pad Screw
4	005312-40	Pedal Valve Bonnet
5	012512-45	E-Clip Retaining Ring
6	001123-45	Nylon Set Screw
7	000952-45	Nut
8	000239-30	Pedal, Blank RH
9	001602-45	Bushing, Pedal Valve
10	000887-45	Spring, RH (Cold Pedal)
11	001483-25	Pedal Spring Screw & Spacer

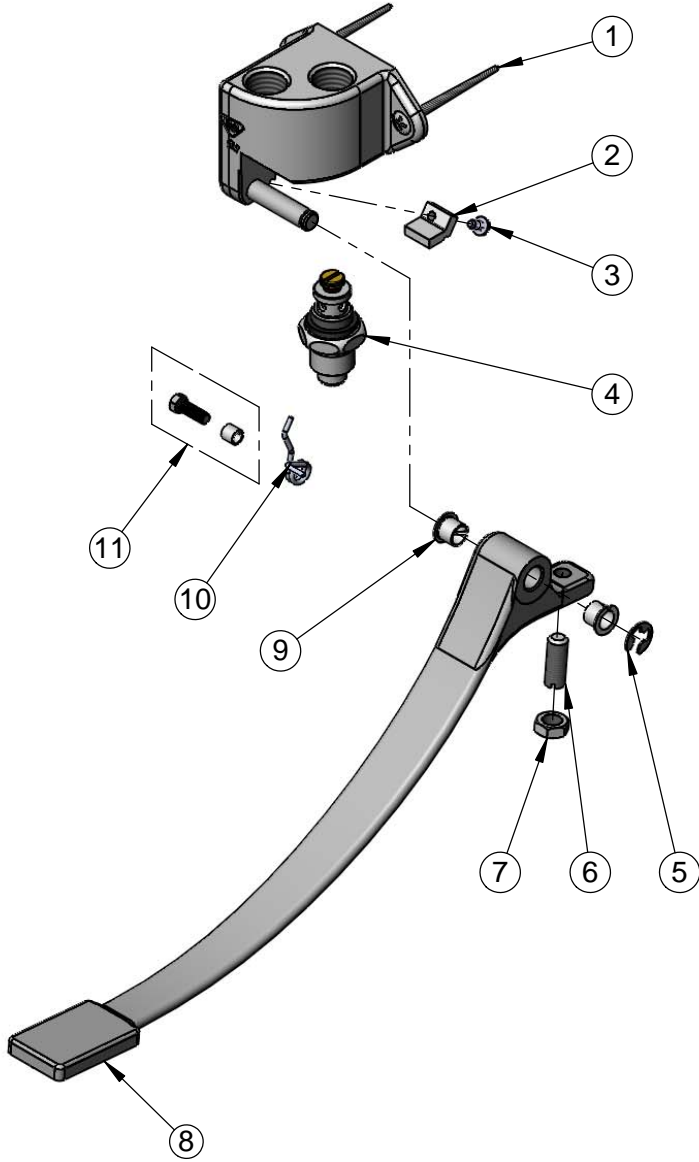

Product Specifications:
 Single Wall Mount Pedal Valve w/ Volume Control & 1/2" NPT
 Female Inlet and Outlet

Product Compliance:
 ASME A112.18.1 / CSA B125.1
 NSF 61 - Section 9
 NSF 372 (Low Lead Content)