



T&S BRASS AND BRONZE WORKS, INC.
 2 Saddleback Cove / P.O. Box 1088
 Travelers Rest, SC 29690

Model No.
B-0044-H3

Item No.

Travelers Rest, SC: 800-476-4103 • Simi Valley, CA: 800-423-0150 • Fax: 864-834-3518 • www.tsbrass.com

This Space for Architect/Engineer Approval

Job Name _____ Date _____

Model Specified _____ Quantity _____

Customer/Wholesaler _____

Contractor _____

Architect/Engineer _____

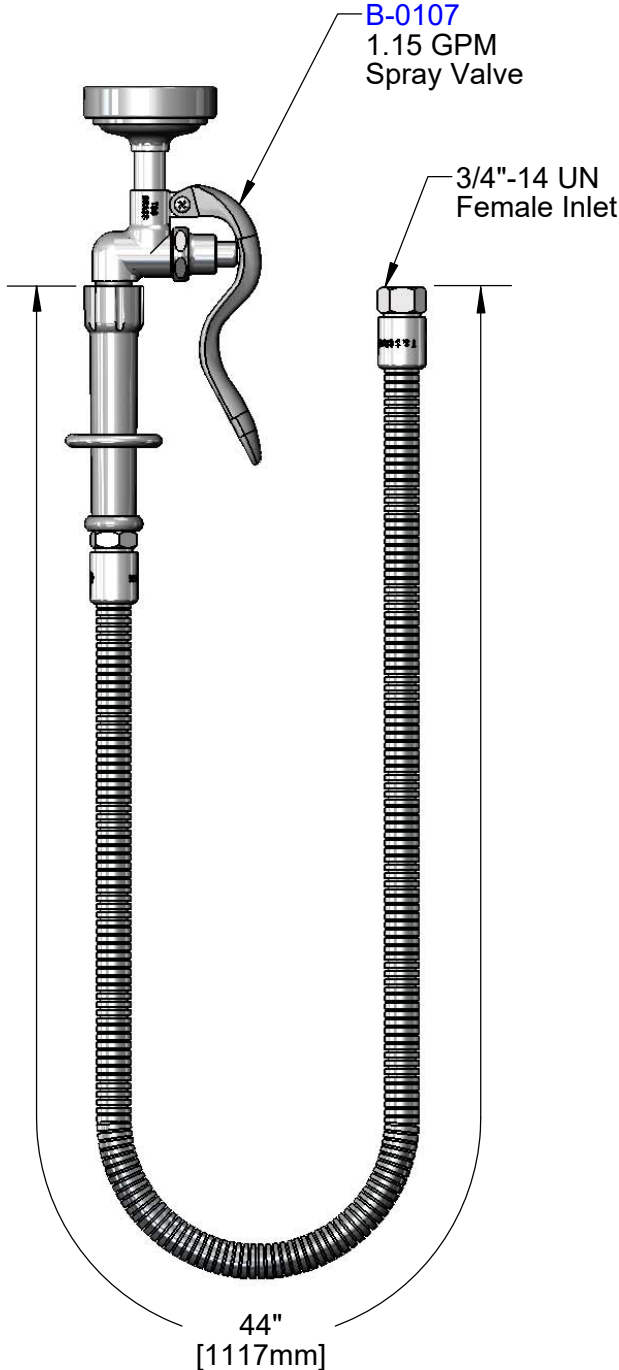

053A
 Adapter
 3/8" NPT Male x
 3/4"-14 UN Male
 (Included)



172A
 Adapter
 1/4" NPT Male x
 3/4"-14 UN Male
 (Included)

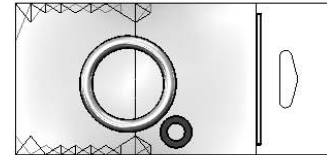

Hold Down Ring
 & Washer
 (Included)

Product Specifications:
 44" Flexible Stainless Steel Hose w/ Adapters & 1.15 GPM Spray Valve

Product Compliance:
 ASME A112.18.1 / CSA B125.1
 NSF 61 - Section 9
 NSF 372 (Low Lead Content)
 2019 DOE PRSV - Class II



T&S BRASS AND BRONZE WORKS, INC.
 2 Saddleback Cove / P.O. Box 1088
 Travelers Rest, SC 29690

Model No.
B-0044-H3

Item No.

Travelers Rest, SC: 800-476-4103 • Simi Valley, CA: 800-423-0150 • Fax: 864-834-3518 • www.tsbrass.com

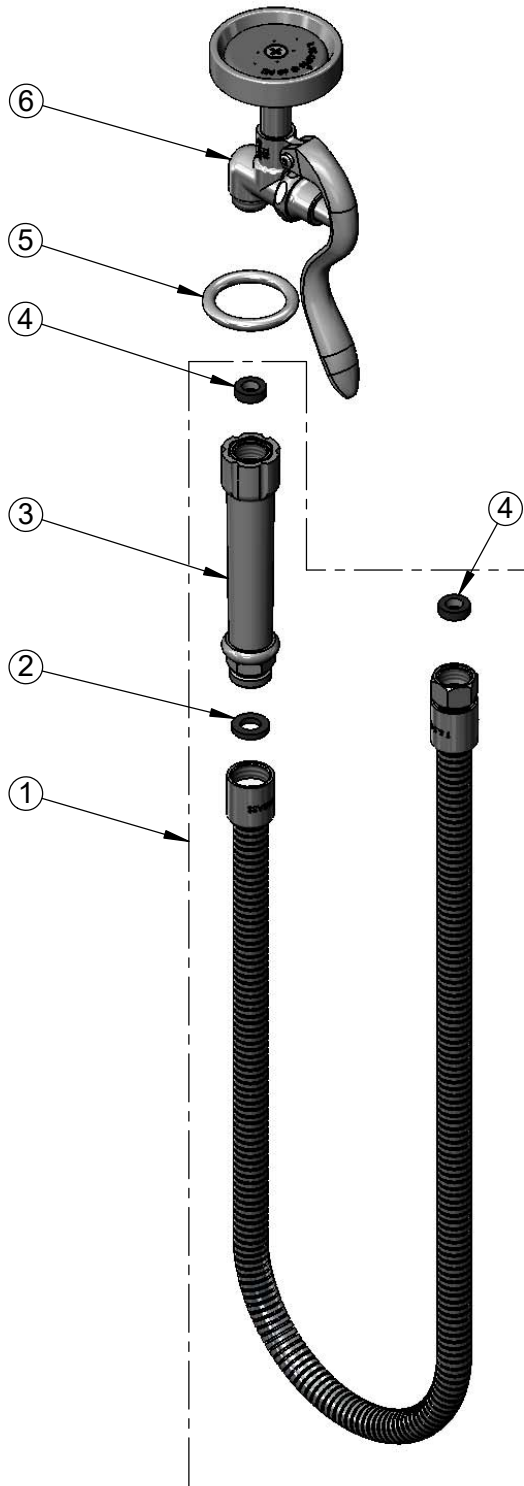

ITEM NO.	SALES NO.	DESCRIPTION
1	B-0044-H	44" Flexible Stainless Steel Hose
2	001014-45	Washer, B-0100 Hose Barrel
3	002987-40	Grip Handle
4	010476-45	#27 Washer
5	000907-45	Spray Valve Hold Down Ring
6	B-0107	1.15 GPM Spray Valve
7	053A	Adapter, 3/8" NPT Male x 3/4"-14 UN Male
8	172A	Adapter, 1/4" NPT Male x 3/4"-14 UN Male

Product Specifications:
 44" Flexible Stainless Steel Hose w/ Adapters & 1.15 GPM Spray Valve

Product Compliance:
 ASME A112.18.1 / CSA B125.1
 NSF 61 - Section 9
 NSF 372 (Low Lead Content)
 2019 DOE PRSV - Class II