

This Space for Architect/Engineer Approval

Job Name _____ Date _____

Model Specified _____ Quantity _____

Customer/Wholesaler _____

Contractor _____

Architect/Engineer _____

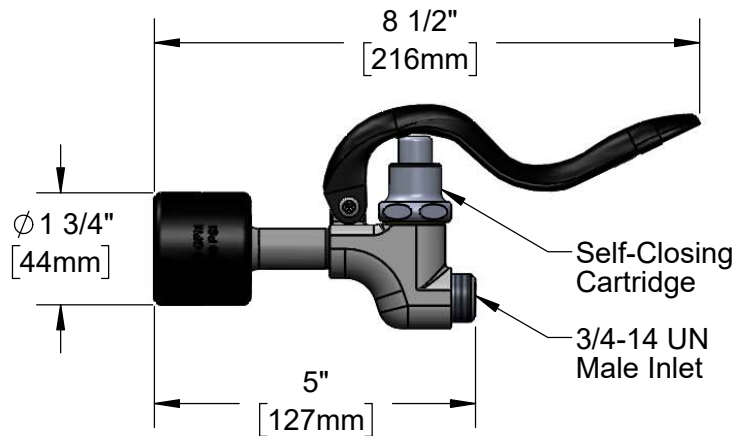

Flow Rate: 1.20 GPM (4.54 L/min) @ 60 psi
Spray Force: 7.7 Ozf (218 Gramf) @ 60 psi

Model Number 5SV-C	Product Specifications: 1.20 GPM Spray Valve For Pre-Rinse Unit				
Product Compliance: ASME A112.18.1 / CSA B125.1 NSF 61 - Section 9 NSF 372 (Low Lead Content) 2019 DOE PRSV - Class II	 <p>equip Foodservice Accessories</p> <p>2 Saddleback Cove, P.O. Box 1088 Travelers Rest, South Carolina 29690 Phone: 800.891.4808 Fax: 800.868.0084 equip.tsbrass.com</p>				
Drawn: CDS	Checked: JMD	Approved: JHB	Date: 08/25/22	Scale: 1:4	Sheet: 1 of 1