

This Space for Architect/Engineer Approval

Job Name _____ Date _____

Model Specified _____ Quantity _____

Customer/Wholesaler _____

Contractor _____

Architect/Engineer _____

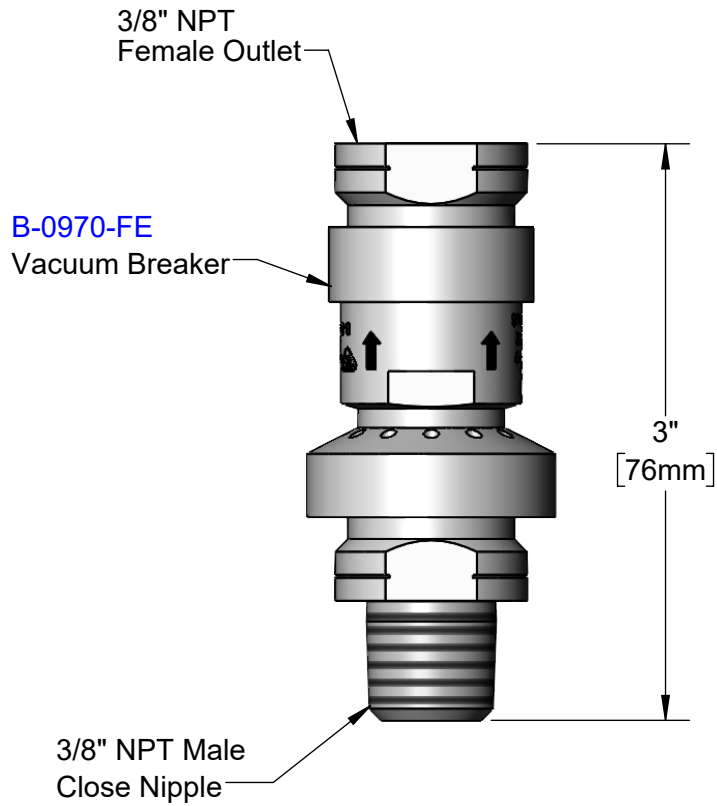
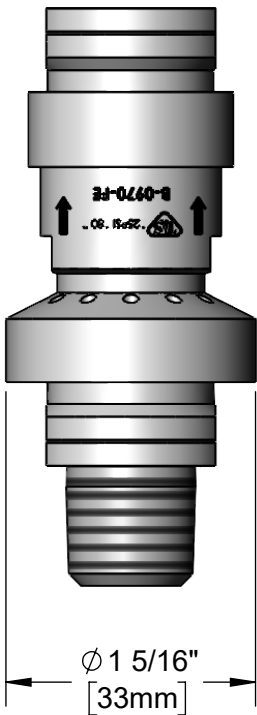
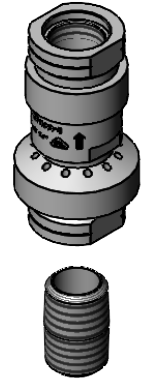

Model Number

5PR-VB

Product Specifications:

Dual Check Vacuum Breaker with Intermediate Vent, 3/8" NPT Female Inlet & Outlet (for Continuous Pressure Applications) w/ 3/8" NPT Close Nipple

Product Compliance:

ASME A112.18.1 / CSA B125.1
NSF 61 - Section 9
NSF 372 (Low Lead Content)
CSA B64.8 (VB)

equip
Foodservice
Accessories

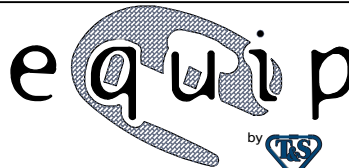

2 Saddleback Cove, P.O. Box 1088
Travelers Rest, South Carolina 29690
Phone: 800.891.4808 Fax: 800.868.0084
equip.tsbrass.com

ITEM NO.	SALES NO.	DESCRIPTION
1	B-0970-FE	3/8" NPT Vacuum Breaker
2	002535-25	3/8" NPT Close Nipple

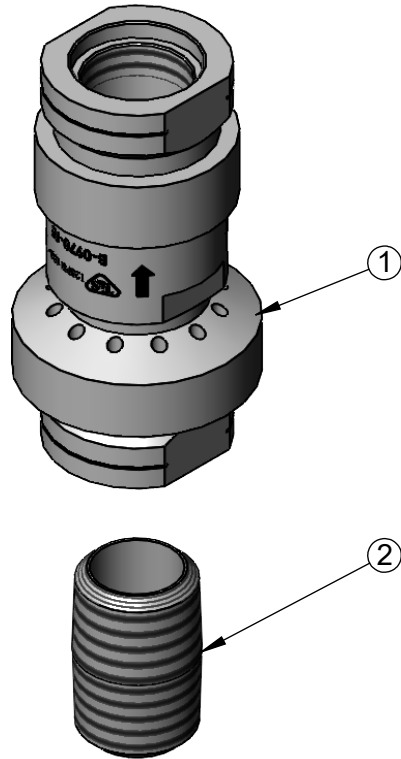

Model Number

5PR-VB

Product Specifications:

Dual Check Vacuum Breaker with Intermediate Vent, 3/8" NPT Female Inlet & Outlet (for Continuous Pressure Applications) w/ 3/8" NPT Close Nipple

Product Compliance:

ASME A112.18.1 / CSA B125.1
 NSF 61 - Section 9
 NSF 372 (Low Lead Content)
 CSA B64.8 (VB)

equip
 Foodservice
 Accessories

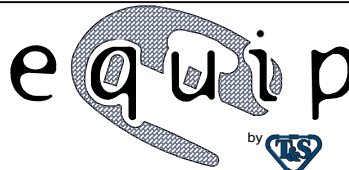

2 Saddleback Cove, P.O. Box 1088
 Travelers Rest, South Carolina 29690
 Phone: 800.891.4808 Fax: 800.868.0084
 equip.tsbrass.com