

*This Space for Architect/Engineer Approval*

Job Name \_\_\_\_\_ Date \_\_\_\_\_  
 Model Specified \_\_\_\_\_ Quantity \_\_\_\_\_  
 Customer/Wholesaler \_\_\_\_\_  
 Contractor \_\_\_\_\_  
 Architect/Engineer \_\_\_\_\_

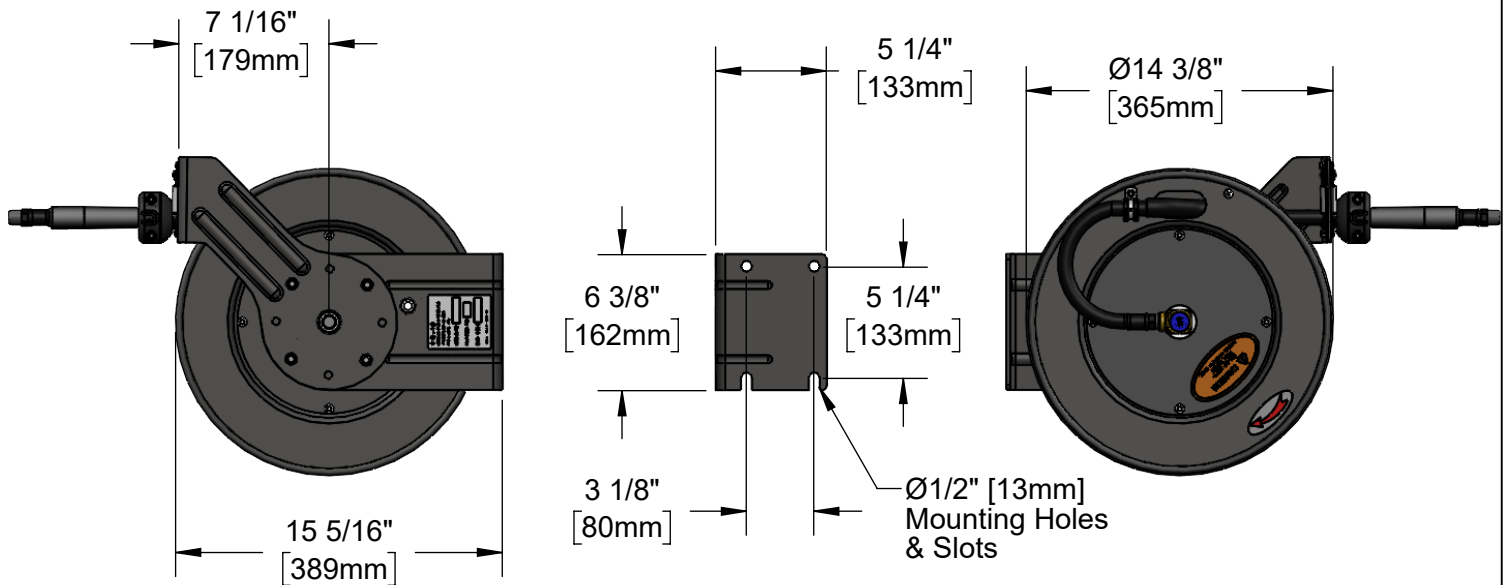
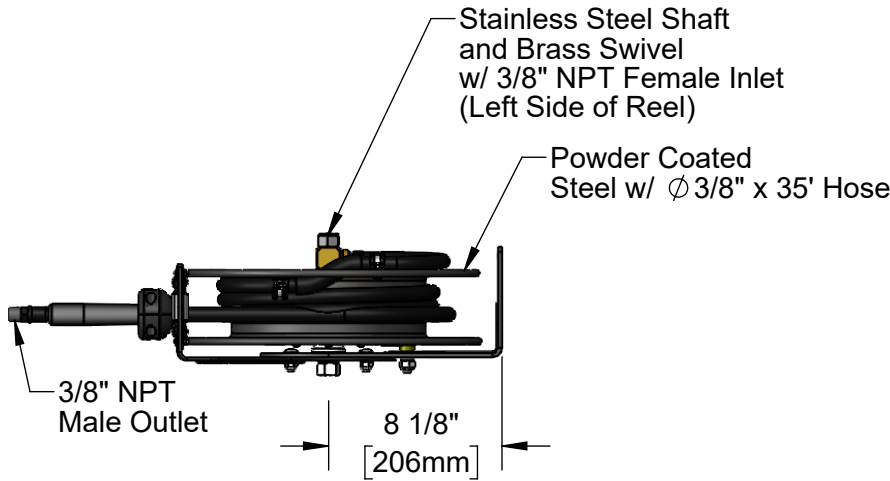
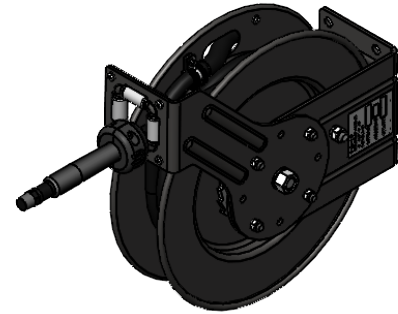

Model Number  
**5HR-232**

Product Compliance:  
 NSF 61 Exempt (Non-Potable)

Product Specifications:  
 Powder Coated Steel, Open Hose Reel  
 w/ 3/8" x 35' Hose, Less Spray Valve

equip  
 Foodservice  
 Accessories



by 

2 Saddleback Cove, P.O. Box 1088  
 Travelers Rest, South Carolina 29690  
 Phone: 800.891.4808 Fax: 800.868.0084  
 equip.tsbrass.com

ITEM NO.	SALES NO.	DESCRIPTION
1	5HR-2SA	Complete 3/8" Swivel Assembly
2	014948-45	Seal Kit
3	G016682-45	Spring Assembly
4	014940-45	Ratchet Repair Kit
5	5HR-2HSE-35	∅ 3/8" x 35' Hose
6	019246-45	Hose Stop Repair Kit
7	G016631-45	Roller Kit

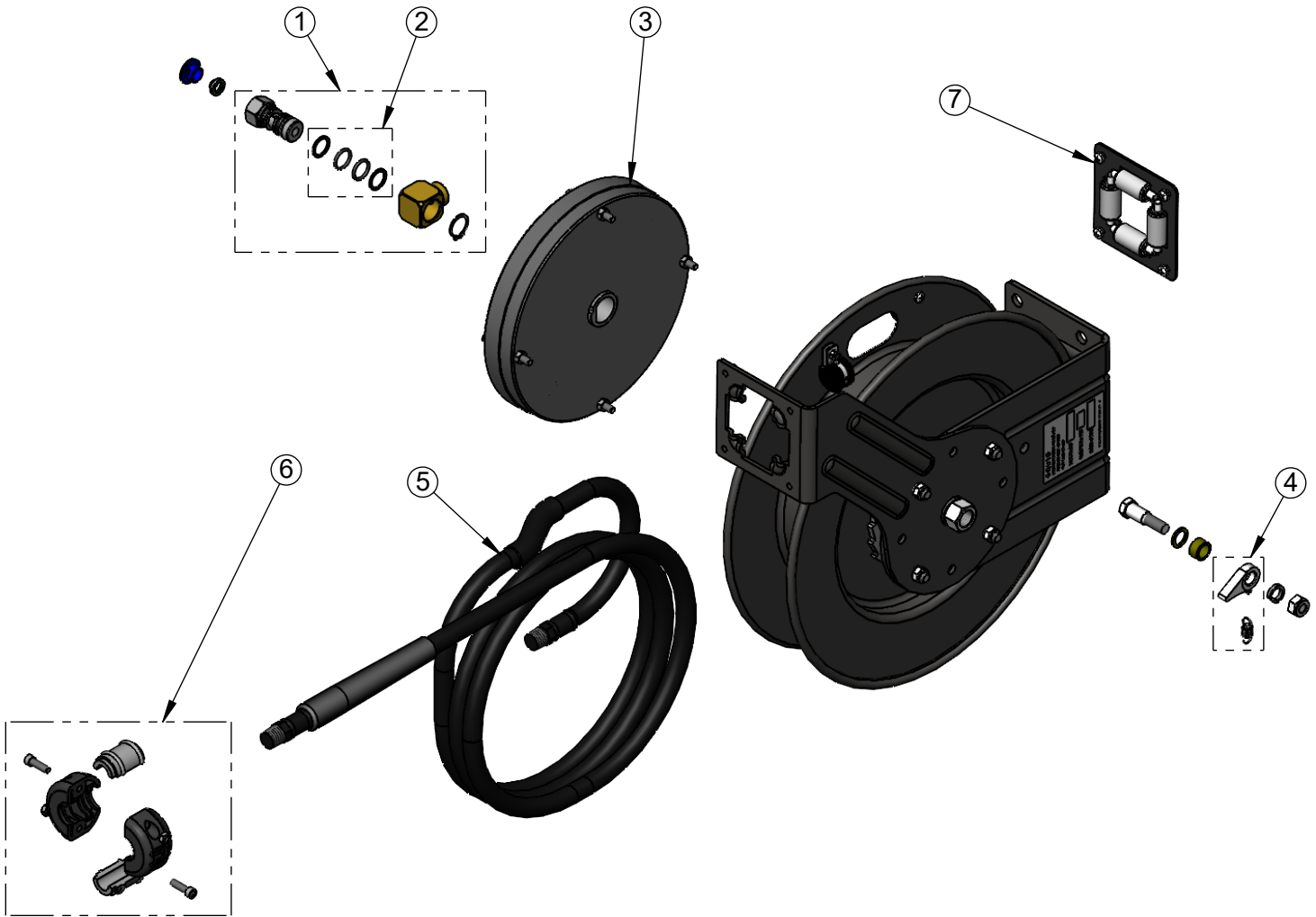

Model Number

**5HR-232**

Product Specifications:

Powder Coated Steel, Open Hose Reel  
w/ 3/8" x 35' Hose, Less Spray Valve

Product Compliance:

NSF 61 Exempt (Non-Potable)

equip  
Foodservice  
Accessories

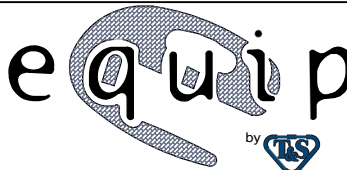

2 Saddleback Cove, P.O. Box 1088  
Travelers Rest, South Carolina 29690  
Phone: 800.891.4808 Fax: 800.868.0084  
equip.tsbrass.com