



ADA Compliant

This Space for Architect/Engineer Approval

Job Name _____ Date _____

Model Specified _____ Quantity _____

Customer/Wholesaler _____

Contractor _____

Architect/Engineer _____

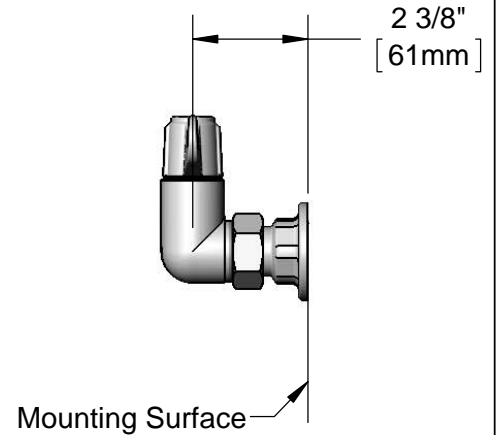
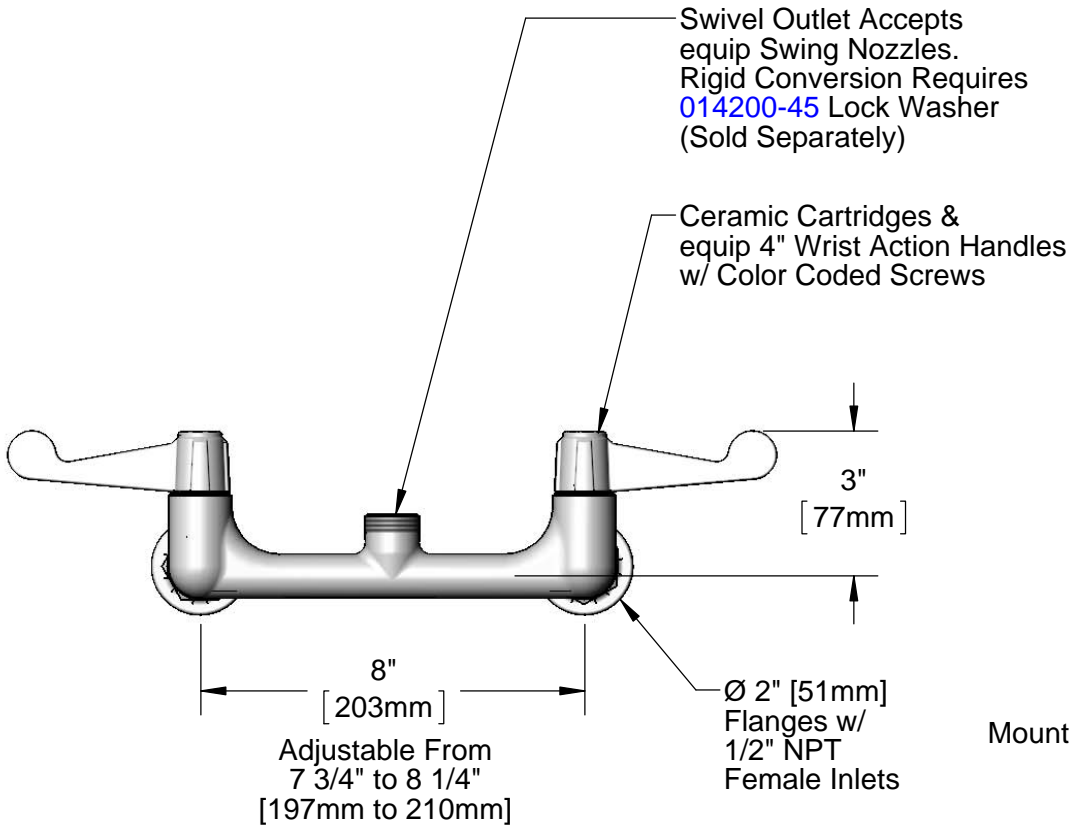
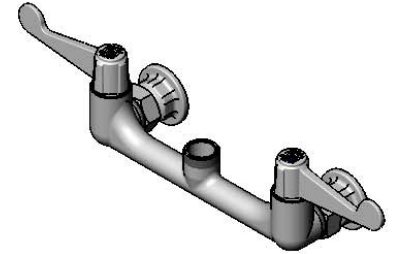
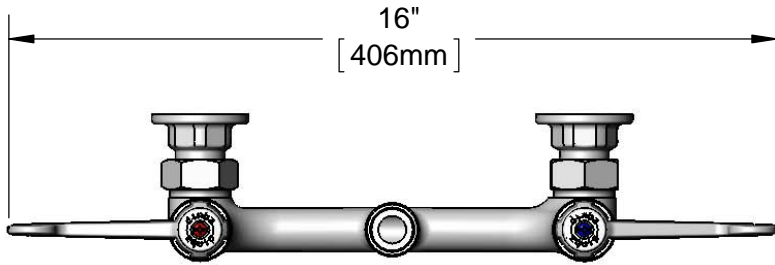

Model Number
5F-8WWX00

Date
05/14/13

Scale
1:4

Drawn
KJG

Checked
DMH

Approved
JHB



Product Specifications:

**8" Wall Mount Mixing Faucet w/ Ceramic Cartridges,
equip 4" Wrist Action Handles, 1/2" NPT Female Inlets
& Less Nozzle**

equip Foodservice Accessories
2 Saddleback Cove, P.O. Box 1088
Travelers Rest, South Carolina 29690
Phone: 800.891.4808 Fax: 800.868.0084

ITEM NO.	SALES NO.	DESCRIPTION
1	5-HDL-W	equip 4" Wrist Action Handle w/ Color Coded Screws
2	00AA	1/2" NPT Female Eccentric Flange
3	001019-45	Coupling Nut Washer
4	013788-45	equip Ceramic Cartridge, LTC
5	013787-45	equip Ceramic Cartridge, RTC

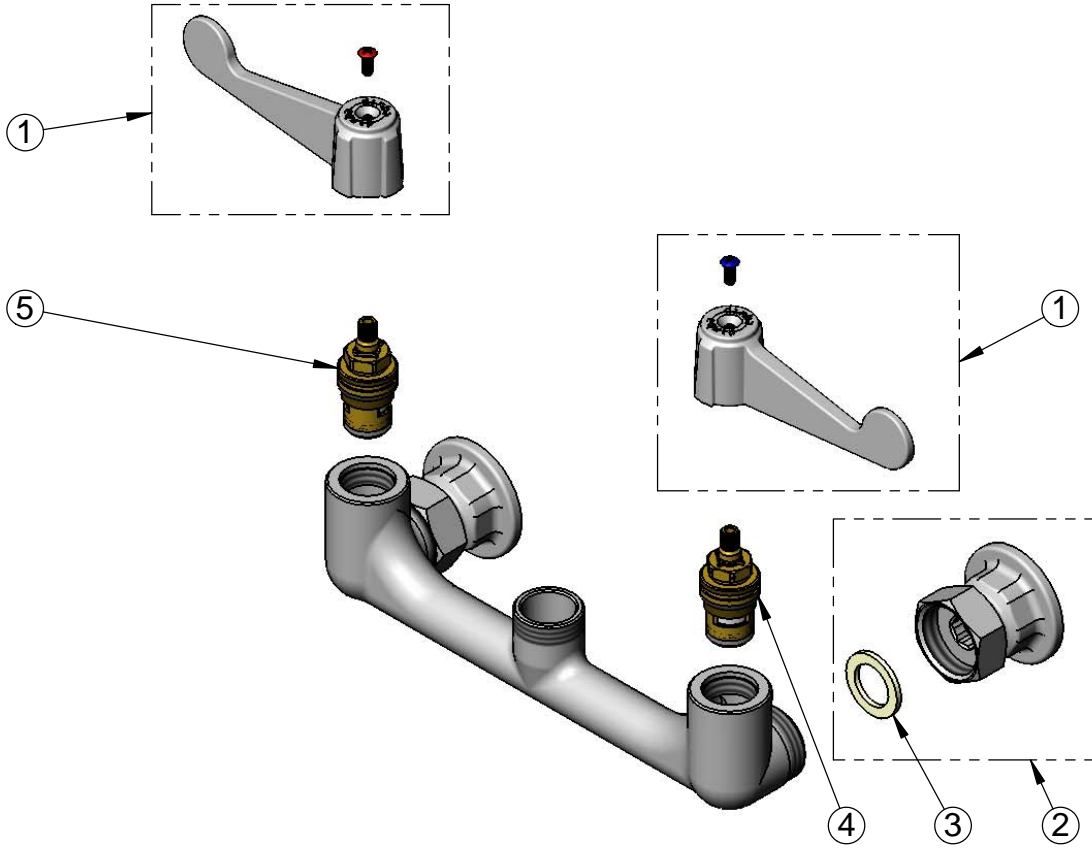

Model Number 5F-8WWX00	Date 05/14/13	Scale 1:8	Drawn KJG	Checked DMH	Approved JHB
----------------------------------	------------------	--------------	--------------	----------------	-----------------



Product Specifications:
**8" Wall Mount Mixing Faucet w/ Ceramic Cartridges,
equip 4" Wrist Action Handles, 1/2" NPT Female Inlets
& Less Nozzle**

equip Foodservice Accessories
2 Saddleback Cove, P.O. Box 1088
Travelers Rest, South Carolina 29690
Phone: 800.891.4808 Fax: 800.868.0084