



T&S BRASS AND BRONZE WORKS, INC.
 2 Saddleback Cove / P.O. Box 1088
 Travelers Rest, SC 29690

Model No.
006480-40NS

Item No.

Travelers Rest, SC: 800-476-4103 • Simi Valley, CA: 800-423-0150 • Fax: 864-834-3518 • www.tsbrass.com



ADA Compliant

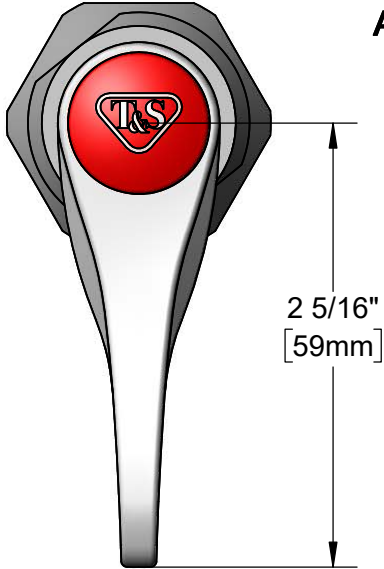

This Space for Architect/Engineer Approval

Job Name _____ Date _____

Model Specified _____ Quantity _____

Customer/Wholesaler _____

Contractor _____

Architect/Engineer _____

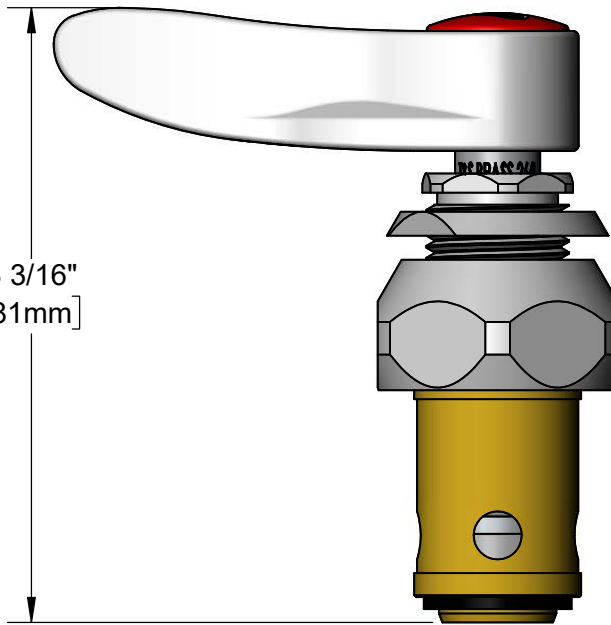
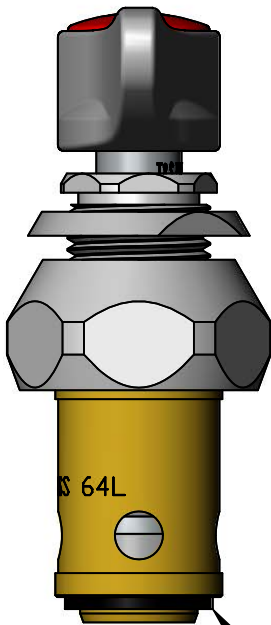

Bottom Gasket

Product Specifications:

Quarter-Turn Eterna Cartridge, RTC w/ Spring Check, Lever Handle, Index (Red), Screw & New Style Escutcheon Bonnet

Product Compliance:

ASME A112.18.1 / CSA B125.1
 NSF 61 - Section 9
 NSF 372 (Low Lead Content)
 ANSI A117.1 (ADA)



T&S BRASS AND BRONZE WORKS, INC.
 2 Saddleback Cove / P.O. Box 1088
 Travelers Rest, SC 29690

Model No.
006480-40NS

Item No.

Travelers Rest, SC: 800-476-4103 • Simi Valley, CA: 800-423-0150 • Fax: 864-834-3518 • www.tsbrass.com

ITEM NO.	SALES NO.	DESCRIPTION
1	006478-40NS	Quarter-Turn Eterna Cartridge w/ Spring Check, CWS Escutcheon Bonnet, RTC
2	001638-45NS	Lever Handle (New Style)
3	000925-45	Lab Handle Screw
4	001193-19NS	Red Button Index, Press-in

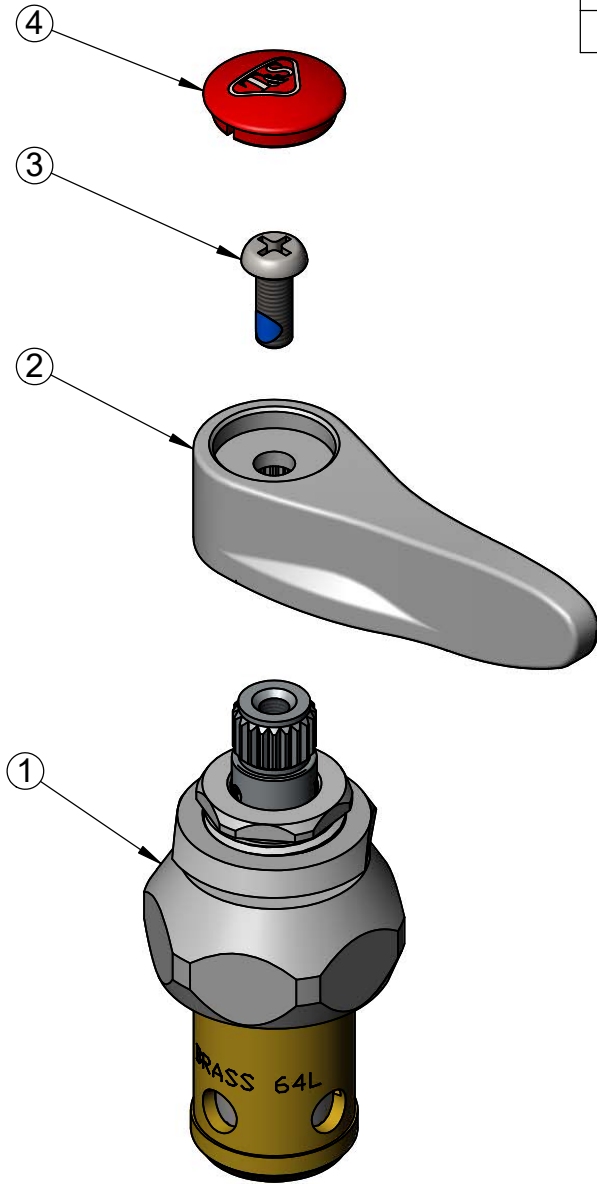

Product Specifications:
 Quarter-Turn Eterna Cartridge, RTC w/ Spring Check, Lever Handle, Index (Red), Screw & New Style Escutcheon Bonnet

Product Compliance:
 ASME A112.18.1 / CSA B125.1
 NSF 61 - Section 9
 NSF 372 (Low Lead Content)
 ANSI A117.1 (ADA)