



Turbo Air Speeds up the Pace of Innovation

Undercounter Freezer Service Manual

Please read this manual completely before attempting to install or operate this equipment!

Undercounter Freezers

MUF-28

MUF-48

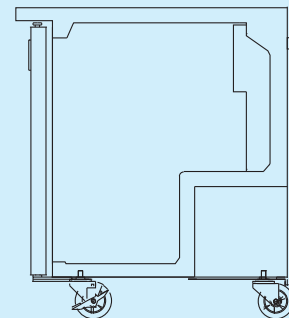
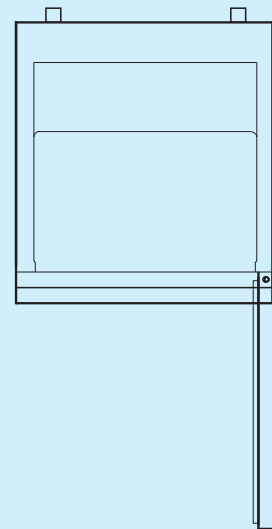

TABLE OF CONTENTS

1. FEATURE CHART

1-1. FRONT VIEW

1-2. SIDE VIEW

2. WIRING DIAGRAMS

2-1. MUF-28

2-2. MUF-48

3. PART DETAILS

3-1. COMPRESSOR COMPARTMENT

3-2. DOOR

3-3. REFRIGERATION COMPARTMENT

4. MAIN COMPONENTS

5. TEMPERATURE CONTROL INSTRUCTION

5-1. HOW TO USE THE TEMPERATURE CONTROL

5-2. FUNCTION TABLE

6. PARTS LIST

7. REPLACEMENT OF MAIN COMPONENTS

6-1. REPLACING DOOR

6-2. REFRIGERATION COMPARTMENT PARTS

6-3. COMPRESSOR COMPARTMENT PARTS

6-4. REPLACING THE EVAPORATOR & EVAPORATOR FAN MOTOR

1. FEATURE CHART

1-1. FRONT VIEW

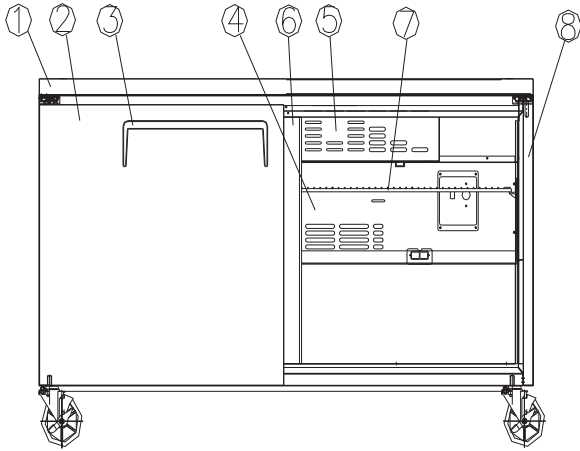

MUF-48

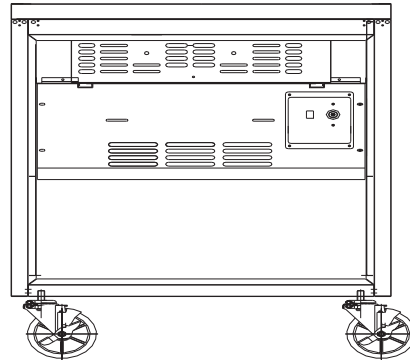

MUF-28

1-2. SIDE VIEW

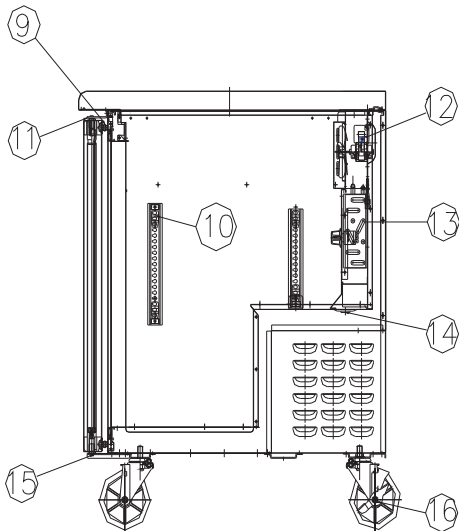

- 1 COUNTER TOP
- 2 DOOR(L)
- 3 DOOR HANDLE(L)
- 4 EVAPORATOR DUCT
- 5 LOUVER
- 6 MULLION
- 7 SHELF(R)
- 8 CABINET ASSEMBLY
- 9 DOOR GASKET
- 10 SHELF CLIP
- 11 TOP HINGE
- 12 EVAPORATOR FAN MOTOR
- 13 EVAPORATOR COIL
- 14 EVAPORATOR DRAIN GUIDE
- 15 DOOR BOTTOM HINGE
- 16 CASTOR

3. PART DETAILS

3-1. COMPRESSOR COMPARTMENT



MUF-48



MUF-28

CONDENSER UNIT ASSEMBLY

3-2. DOOR

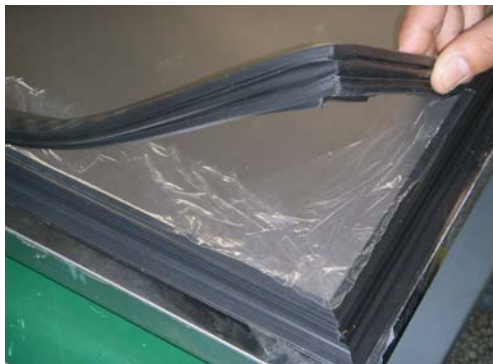

DOOR GASKET

3-3. REFRIGERATION COMPARTMENT



TEMPERATURE CONTROL & EVAPORATOR ,THERMOSTAT

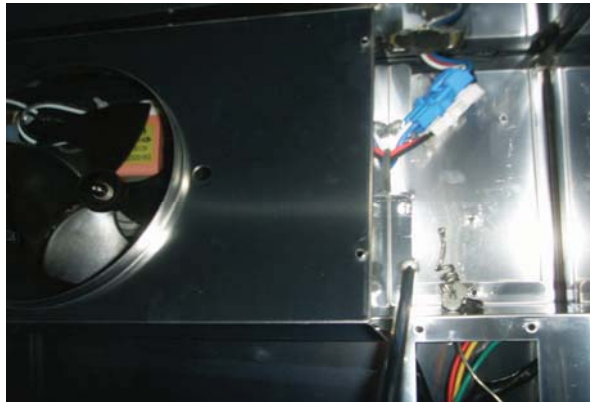

EVAPORATOR FAN MOTOR

4.MAIN COMPONENTS

1.COMPRESSOR

MODEL	PART NAME	PART NO.	HORSE	CAPACITY	TYPE OF	INPUT	MAKER
MUF-48	CAE2420Z	G2F5700100	1/3HP	~	CSR	115V 60Hz	TECUMSHE
MUF-28	HBL-27YE-1	M369700100	1/4HP	~	CSR	110-115V 60Hz	DAEWOO

2.COMPRESSOR RELAY ,OVERLOAD

MODEL	RELAY	PART NO.	OVERLOAD	PART NO.	MAKER	NOTE
MUF-48	3ARR12	~	MST16AHN-3240	~	TECUMSHE	~
MUF-28	GSR SO68 E03 03	~	783RHBZZ-52	~	DAEWOO	~

3.COMPRESSOR CAPACITOR

MODEL	STARTING	PART NO.	RUNNING	PART NO.	MAKER	NOTE
MUF-48	250V/160uF	~		~	~	~
MUF-28	125V/100uF	~	250V/10uF	~	~	~

4.CONDENSER FAN MOTOR

MODEL	PART NAME	PART NO.	POLE	INPUT	TYPE	BLADE	MAKER
MUF-48	IS-4420DWSN-2A	3963328120	4P	115V 60Hz	SHADED POLE INDUCTION	AL 5	SUNGSHIN
MUF-28	IS-4420DWSN-2A	3963328120					

5.EVAPORATOR FAN MOTOR

MODEL	PART NAME	PART NO.	POLE	INPUT	TYPE	BLADE (NUMBER)	MAKER
MUF-48	DAI-6202DEUA	M729900200	2P	115v 60Hz	SHADED POLE INDUCTION	ZYTEL 4	SUNGSHIN
MUF-28	DAI-6202DEUA		2P	115v 60Hz			

6.THERMOSTAT

PART NAME	PART NO.	RATING	MAKER
THERMOSTAT	~	PAF-7037-01	RANCO
		MUF-48	
THERMOSTAT	~	PAF-7037-02	RANCO
		MUF-28	

5. TEMPERATURE CONTROL INSTRUCTION

5-1. HOW TO USE THE TEMPERATURE CONTROL

-Indicates temperature level setting

-Temperature can be controlled by the user
 -Factory setting is at "NORMAL". Settings can be changed by Dial Knob.

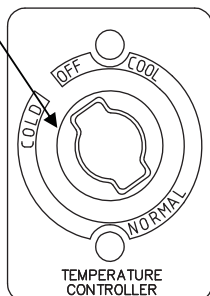

- If thermostat knob is pointing at OFF, compressor and condenser fan motor would not run.
- Keep unit unplugged, if not in use for a long period of time.

5-2. FUNCTION TABLE

No	Function	Controlled	Description												
1	Tempressor Control Model: MUF-28	Compressor Evap. Fan motor Cond. Fan Motor	1. The temperature can be changed by turning the dial knob 2. Compressor is automatically turned on and off by thermostat.												
			■ Cut in and out temperature chart. ° F												
			<table border="1"> <thead> <tr> <th>NO.</th> <th>Cool</th> <th>Normal</th> <th>Cold</th> </tr> </thead> <tbody> <tr> <td>Cut in</td> <td>9.5±1.5</td> <td>5.9±1.5</td> <td>4.1±1.5</td> </tr> <tr> <td>Cut Out</td> <td>-3.1</td> <td>-6.7</td> <td>-7.5</td> </tr> </tbody> </table>	NO.	Cool	Normal	Cold	Cut in	9.5±1.5	5.9±1.5	4.1±1.5	Cut Out	-3.1	-6.7	-7.5
NO.	Cool	Normal	Cold												
Cut in	9.5±1.5	5.9±1.5	4.1±1.5												
Cut Out	-3.1	-6.7	-7.5												
2	Model: MUF-48		<table border="1"> <thead> <tr> <th>NO.</th> <th>Cool</th> <th>Normal</th> <th>Cold</th> </tr> </thead> <tbody> <tr> <td>Cut in</td> <td>2.3±1.5</td> <td>-1.3±1.5</td> <td>-3.1±1.5</td> </tr> <tr> <td>Cut Out</td> <td>-9.4</td> <td>-13</td> <td>-14.8</td> </tr> </tbody> </table>	NO.	Cool	Normal	Cold	Cut in	2.3±1.5	-1.3±1.5	-3.1±1.5	Cut Out	-9.4	-13	-14.8
			NO.	Cool	Normal	Cold									
			Cut in	2.3±1.5	-1.3±1.5	-3.1±1.5									
Cut Out	-9.4	-13	-14.8												

6. PARTS LIST FOR M3 MUF

Part name	Part code	Description	Model		Remark
			48	28	
COUNTER TOP					
COUNTER TOP Assembly	WR25700100	SUS304-#4		1	
COUNTER TOP Assembly	WR45700100	SUS304-#4	1		
CASTER	M726500100	5INCH MOVING	2	2	SAME AS SD SERIES
CASTER	M726500200	5INCH MOVING STOPPING	2	2	SAME AS SD SERIES
DOOR					
TOP HINGE (R)	M722900100	SUS304-2B, SM45C	1	1	SAME AS SD SERIES
TOP HINGE (L)	M722900200	SUS304-2B, SM45C	1		SAME AS SD SERIES
TOP HINGE SPACER	M725000100	SUS439-2B	2	1	SAME AS SD SERIES
BOTTOM HINGE (U)(R)	30229M0400	SUS304-2B, SM45C	1	1	SAME AS SD SERIES
BOTTOM HINGE (U)(L)	30229M0300	SUS304-2B, SM45C	1		SAME AS SD SERIES
DOOR GASKET	M272300100	PVC		1	SAME AS SD SERIES
DOOR GASKET	M722300100	PVC	2		SAME AS SD SERIES
DOOR Assembly (R)	WM20000900	SUS304-#4		1	
DOOR Assembly (R)	WM71700100	SUS304-#4	1		
DOOR Assembly (L)	WM71700200	SUS304-#4	1		
DOOR BUSHING	M720700100	PA-66	4	2	SAME AS SD SERIES
COMPRESSOR COMPARTMENT					
COMPRESSOR	M369700100	HBL-27YE-1 (1/4HP)		1	SAME AS SD SERIES
COMPRESSOR	G2F5700100	SK1A1C-L2W (1/3HP)	1		SAME AS SD SERIES
SUCTION PIPE(B)	UF24400100	CU		1	SAME AS SD SERIES
SUCTION PIPE(B)	UF44400100	CU	1		SAME AS SD SERIES
SUCTION PIPE(A)	UF24400200	CU		1	SAME AS SD SERIES
SUCTION PIPE(A)	UF44400200	CU	1		SAME AS SD SERIES
COMP BASE	M270300100	GI		1	SAME AS SD SERIES
COMP BASE	M600300100	GI	1		SAME AS SD SERIES

Part name	Part code	Description	Model		Remark
			48	28	
CONDENSER FAN MOTOR	3963328120	IS4420DWSN-2A	1	1	SAME AS SD SERIES
POWER CORD	M721300100	KKP-30(9.85FT)	1	1	SAME AS SD SERIES
CONDENSER FAN AIR GUIDE	M722500900	GI			SAME AS SD SERIES
DRAIN PIPE	UF44400500	CU	1		SAME AS SD SERIES
CONDENSER MOTOR BRACKET	3020602200	GI	1	1	SAME AS SD SERIES
CONDENSER FAN BLADE	M729800100	AL	1	1	SAME AS SD SERIES
REFRIGERATION COMPARTMENT					
EVAP FAN MOTOR	M729900200	DAI-6202DEUA	3	2	SAME AS SD SERIES

Part name	Part code	Description	Model		Remark
			48	28	
LOUVER	UF25800100	SUS439-2B		1	SAME AS SD SERIES
LOUVER	UF45800100	SUS439-2B	1		SAME AS SD SERIES
SHELF	WM77800100	Pe-coating(gray)	2		
SHELF	WM27800100	Pe-coating(gray)		1	
FIXTURE SHELF CLIP	30220L0900	PA-66	8	4	SAME AS SD SERIES
SHELF MID BRACKET	M720600100	SUS304	1		SAME AS SD SERIES
SHELF STANDARD	M725300200	SUS304	8	4	SAME AS SD SERIES
DRAIN PAN GUIDE(R)	M272500100	GI		1	SAME AS SD SERIES
DRAIN PAN GUIDE(L)	M272500200	GI		1	SAME AS SD SERIES
EVAPORATOR AS	UF27000100	CU,SPG,AL		1	SAME AS SD SERIES
EVAPORATOR AS	UF47000100	CU,SPG,AL	1		SAME AS SD SERIES
THERMOSTAT		PAF-7037-01		1	SAME AS SD SERIES
THERMOSTAT		PAF-7037-02	1		SAME AS SD SERIES
EVAPOVATOR FAN DUCT	UF26900200	SUS439-2B		1	SAME AS SD SERIES
EVAPOVATOR FAN DUCT	UF46900200	SUS439-2B	1		SAME AS SD SERIES
EVAPOVATOR DUCT	UF26900100	SUS439-2B		1	SAME AS SD SERIES
EVAPOVATOR DUCT	UF46900100	SUS439-2B	1		SAME AS SD SERIES
MULLION FRAME	M722200400	PVC	1		SAME AS SD SERIES
MULLION BACK FRAME	M722200200	SUS439-2B	1		SAME AS SD SERIES
MULLION FRAME INSULATION	M723300100	F-PS	1		SAME AS SD SERIES
CONDENSER AS	UF25900101	CU,SPG,AL		1	SAME AS SD SERIES
CONDENSER AS	UF45900101	CU,SPG,AL	1		SAME AS SD SERIES
BRACKET MOTOR	UF40600101	SUS304-2B	3	2	SAME AS SD SERIES
FAN COOLING BLADE	3011802210	ZYTEL	3	2	SAME AS SD SERIES
SPACER CUSHION	M721500300	RUBBER	4	4	SAME AS SD SERIES

7. REPLACEMENT OF MAIN COMPONENTS

7-1. REPLACING DOOR

A. Unscrew the top hinge



B. Lift the door



7-2. REFRIGERATION COMPARTMENT PARTS

A. Disassemble the evaporator fan duct assembly



REPLACEMENT OF MAIN COMPONENTS



B. Disassemble the evaporator fan motor

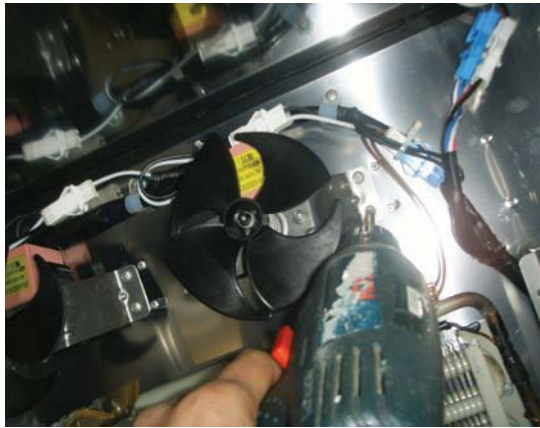

D. Disassemble the evaporator duck



REPLACEMENT OF MAIN COMPONENTS

E.Remove the thermostat & sensor

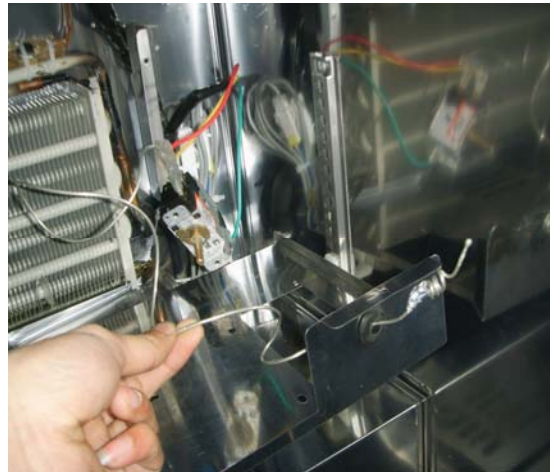

F.Remove the evaporator coil



7-3.COMPRESSOR COMPARTMENT PARTS

A.Disassemble the rear grill



REPLACEMENT OF MAIN COMPONENTS

B. Disassemble the cable tie



C. Disassemble the condensing unit



two screws as above



Pull out the condensing unit

D. Disassemble the condenser fan motor



REPLACEMENT OF MAIN COMPONENTS

7-4.REPLACING THE EVAPORATOR & EVAPORATOR FAN MOTOR.

A.Unscrew the screw located on both sides and top of the evap duct assamble fixture



D.Unscrew the screws located on left and right side of the evap duct.

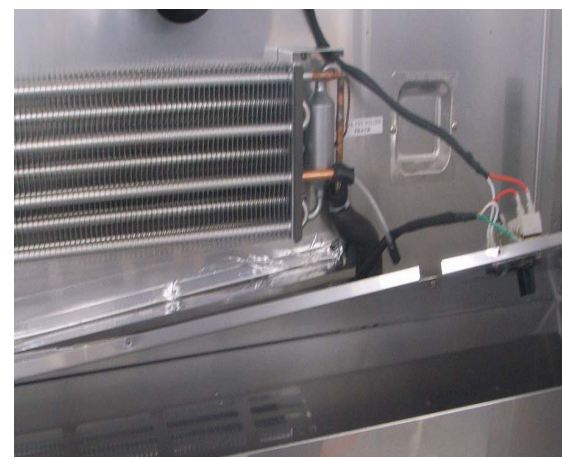

REPLACEMENT OF MAIN COMPONENTS

E. And then, you can replace fan motor, evaporator coil and thermo sensor.

