

Service Manual



ETL Blast Chiller Series



Safety Precautions

THIS MANUAL HAS BEEN PREPARED FOR PERSONNEL QUALIFIED TO INSTALL, MAINTAIN AND REPAIR ELECTRICAL REFRIGERATION EQUIPMENT, WHO SHOULD PERFORM THE INITIAL FIELD STARTUP AND ADJUSTMENTS OF THE EQUIPMENT COVERED BY THIS MANUAL.

READ THIS MANUAL THOROUGHLY BEFORE OPERATING, INSTALLING, PERFORMING MAINTENANCE ON, OR REPAIRING THE EQUIPMENT.

⚠ WARNING: Failure to follow all the instructions in this manual can cause property damage, injury or death.

⚠ WARNING: Improper installation, adjustment, alteration, service or maintenance can cause property damage, injury or death.

⚠ WARNING: Electrical connections should be performed only by a certified professional.

⚠ WARNING: Electrical and grounding connections must comply with the applicable portions of the National Electric Code and/or all local electric codes. Failure to comply with this procedure can cause property damage, injury or death.

⚠ WARNING: Before connecting the unit to the electrical supply, verify that the electrical and grounding connections comply with the applicable portions of the National Electric Code and/or other local electrical codes. Failure to comply with this procedure can cause property damage, injury or death.

⚠ WARNING: Before connecting the unit to the electrical supply, verify that the electrical connection agrees with the specifications on the data plate. Failure to comply with this procedure can cause property damage, injury or death.

⚠ WARNING: UL73 grounding instructions: This appliance must be connected to a grounded, metal, permanent wiring system. Or an equipment-grounding conductor must be run with the circuit conductors and connected to the equipment-grounding terminal or lead on the appliance. Failure to comply with this procedure can cause property damage, injury or death.

⚠ WARNING: Appliances equipped with a flexible electric supply cord, are provided with a three-prong grounding plug. It is imperative that this plug be connected into a properly grounded three-prong receptacle. Failure to comply with this procedure can cause property damage, injury or death.

⚠ WARNING: If the receptacle is not the proper grounding type, contact an electrician. Do not remove the grounding prong from the plug. Failure to comply with this procedure can cause property damage, injury or death.

⚠ WARNING: Before performing any service that involves electrical connection or disconnection and/or exposure to electrical components, always perform the Electrical LOCKOUT/TAGOUT Procedure. Disconnect all circuits. Failure to comply with this procedure can cause property damage, injury or death.

⚠ WARNING: Before removing any sheet metal panels, always perform the Electrical LOCKOUT/TAGOUT Procedure. Be sure all circuits are disconnected. Failure to comply with this procedure can cause property damage, injury or death.

⚠ WARNING: Do not operate this equipment without properly placing and securing all covers and access panels. Failure to comply with this procedure can cause property damage, injury or death.

⚠ WARNING: Do not use or store gasoline or other flammable vapors or liquids in the vicinity of this or any other appliance. Failure to comply can cause property damage, injury or death.

⚠ WARNING: In the event of a power failure, do not attempt to operate this appliance. Failure to comply can cause property damage, injury or death.

General Safety

⚠ WARNING: ThermalRite accepts no responsibility for any situation resulting from work carried out in an unprofessional manner, or from the incorrect interpretation or application of regulations.

General Installation

⚠ WARNING: Incorrect installation or any modifications made to the appliance may damage property or result in injury or death.

Electrical

⚠ WARNING: Electrical connections or any work required on the electrical circuits inside the appliance must be performed by certified technicians in compliance with local, state, and federal regulations.

⚠ WARNING: Make sure all facility electrical connections are in compliance with all local and federal electrical code regulations.

Inspection and Maintenance

⚠ WARNING: Appliance maintenance must be carried out by only by suitably trained personnel.

⚠ WARNING: Before any maintenance work is performed, the appliance must be disconnected from the electrical supply. Apply a lockout tag to the electrical supply connection.

⚠ WARNING: All replacement parts that are not supplied by Arctic Air must be pre-approved before installation.

Repair Work Safety

⚠ WARNING: Repair work must only be performed by ThermalRite or one of its authorized representatives. ThermalRite accepts no responsibility for any situation resulting from work performed by untrained and/or unauthorized technicians.

ELECTRICAL LOCKOUT/TAGOUT PROCEDURE

⚠ WARNING: Before performing any service that involves electrical connection or disconnection and/or exposure to electrical components, always follow the Electrical LOCKOUT/TAGOUT Procedure. Disconnect all circuits. Failure to comply can cause property damage, injury or death.

The Electrical LOCKOUT/TAGOUT Procedure is used to protect personnel working on an electrical appliance. Before performing any maintenance or service that requires exposure to electrical components, follow these steps:

1. In electrical box, place appliance circuit breaker into OFF position.
2. Place a lock or other device on electrical box cover to prevent someone from placing circuit breaker ON.
3. Place a tag on electrical box cover to indicate that appliance has been disconnected for service and power should not be restored until tag is removed by maintenance personnel.
4. Disconnect appliance power cord from electrical outlet.
5. Place a tag on the cord to indicate that unit has been disconnected for service and power should not be restored until tag is removed by maintenance personnel.

Table of Contents

	Page
SECTION 1 BASIC SERVICE INFORMATION	9
ALARM/FAILURE LIST	9
FAILURE CODE DETAILS	10
SERVICE MENU – CONFIGURATION PARAMETERS	10
Entering the Configuration Parameters	10
Parameter List (Factory Setting)	10
Temperature Probe Display	15
HACCP PRINTER	16
Printing Alarm List	17
Printing Cycle Data	17
Replacing the printer paper	18
SECTION 2 TROUBLESHOOTING	19
PROBES	19
Checking the Probes	19
Probe Resistance Graph and Chart	20
DOOR SWITCH	23
Checking the Door Switch	23
PRESSURE SWITCH	24
Pressure Switch Working Principles	24
Pressure Switch Factory Setting	24
DOOR FRAME HEATER	25
Heater Cable Specifications	25
MAIN BOARD	25
Testing Relay Outputs	26
KEYPAD	27
Keypad Troubleshooting	27
REFRIGERANT PRESSURE CHECKS	27
Suction Pressure: 1.5 – 2 psig	28
Discharge Pressure: 230 psig	28
SECTION 3 SERVICE AND REPAIR PROCEDURES	29
REMOVING THE FRONT PANEL	29
Models from GBC30SG to GBF171-132S	29
Model GBF15-11S	30
REVERSING THE DOOR SWING	31

	Page
Section 3 (continued)	
ACCESSING THE CONDENSING UNIT (SELF-CONTAINED MODELS)	34
Models from GBC39S to GBF171-132S.....	34
Models from GBC30SG to GBF44-26SP	38
Model GBF15-11S	42
Remote Units – Models GBF440-38R and GBF837-727R	43
ACCESSING THE EVAPORATOR ASSEMBLY	44
Evaporator Assembly Description	44
Accessing the Evaporator	45
REPLACING THE TEMPERATURE SENSING PROBES.....	46
REPLACING THE EVAPORATOR FAN	48
REPLACING THE DOOR SWITCH.....	49
Model GBF15-11S	49
Models GBC30SG to GBF171-132S.....	50
REPLACING THE PRESSURE SWITCH	50
REPLACING THE DOOR FRAME HEATER	51
REPLACING THE RELAY BOARD.....	52
REPLACING THE KEYPAD.....	53
Section 4	
VACUUM AND CHARGING PROCEDURE	54
Vacuum and Charging Instructions.....	55
Vacuum and Charging Recommendations.....	56
SECTION 5	
SCHEMATICS & WIRING DIAGRAMS	57
APPENDICES	57
I. Model Numbers.....	57
II. Data Chart	58
COMPONENT SCHEMATIC.....	59
WIRING – SINGLE-PHASE UNITS (SELF-CONTAINED).....	60
WIRING – 3-PHASE UNITS (SELF-CONTAINED)	61
WIRING – 3-PHASE UNITS (WITH REMOTE CONDENSOR).....	62

Section 1 Basic Service Information

Alarm/Failure List

The Controller will display alarms and failure codes that will assist in identifying the cause of a problem and direct attention to the components and circuits involved. In addition, a diagnostic service menu allows technicians to quickly check the temperature sensors, such as the needle probe, the chamber probe or the evaporator probe.

CODE	CAUSE	CONSEQUENCE
Er0	Chamber Probe Failure	Does not allow unit to cycle. If running, cycle will stop.
Er1	Evaporator Probe Failure	During storage cycle, evaporator fans do not run.
Er3	Needle Probe Failure	Does not allow a needle probe set temperature cycle to run. Unit will stop if running on needle probe set temperature cycle.
HP	High Discharge Pressure or Low Suction Pressure 1	Unit will not operate in any cycle. If running, compressor, evaporator and condenser fans will stop.
d-r	Door is Open for More than P39	Compressor and condenser fan will stop. Evaporator fan will cycle according to P37
AH	High Chamber Temperature	None
AL	Low Chamber Temperature	None
Err	Key Pad – Control Module Communication Error 2	None
RES	Power Failure During Cycle	Cycle will restart when power is restored. Message will flash to indicate cycle has restarted.

¹ The pressure switch in this model series provides a single output, open or closed. The circuit is normally open and will close when either the High or Low Pressure limits are reached. In effect, the failure code, HP, could mean either high discharge pressure as well as low suction pressure.

² Additional troubleshooting at the Key Pad – Control Module connections:

- No Ground connection – Display flashes and/or dims
- No Negative (-) connection – Display may work normally without failure code
- No Positive (+) connection – Failure Code Error is displayed
- No 12V connection – Display will not light up.

Failure Code Details

The HACCP feature provides the ability to get additional information such as failure code, date of occurrence, min/max temperature (if applicable), and duration of alarm condition. To access previous failure codes, press and hold the PROGRAM key for 5 seconds. Use the UP and DOWN arrow keys to scroll through the previous failure codes. Press the PROGRAM key to exit.

Service Menu – Configuration Parameters

Entering the Configuration Parameters

This menu can only be accessed when the unit is in the OFF Mode.

1. Press and hold the UP and DOWN arrow keys at the same time for five (5) seconds.

PA – for password will be displayed in the upper display. No password is needed.
2. Press either the UP or DOWN arrow key to scroll through the menu of parameters.
3. To select a parameter that is being displayed, press the TIME key.
4. To change the value, press the UP or DOWN arrow key.
5. Press the TIME key to save any changes and return to Parameters Menu.

Parameter List (Factory Setting)

The following table shows the factory settings for both Blast Chiller (GBC) and Shock Freezer (GBF) units.

Note: Selecting a freezing cycle on a GBC unit will run a normal chilling cycle (Cabinet at 4°F, needle probe end cycle temperature at 37°F)

CODE	U.O.M.	GBC	DESCRIPTION	GBF
P0	-	0	unit of temperature measurement 0 = °F 1 = °C	0
P1	°F	4	cabinet probe offset	4
P2	°F	0	evaporator probe offset	0
P3	°F	0	needle probe offset	0
GROUP	-	-	MAIN CONTROLLER	-
P4	°F	20	operational setpoint during the second hard chill step; also, operational setpoint during normal chilling (with reference to the cabinet probe)	20
P5	°F	-4	operational setpoint during freezing (with reference to the cabinet probe)	-40

Service Menu – Configuration Parameters (continued)

CODE	U.O.M.	GBC	DESCRIPTION	GBF
P6	°F	-4	operational setpoint during the first hard chill step (with reference to the cabinet probe)	-4
P7	°F	37	operational setpoint during post-chill storage (with reference to the cabinet probe)	37
P8	°F	-4	operational setpoint during post-freeze storage (with reference to the cabinet probe)	-4
P9	°F	2	P4, P5, P6, P7 and P8 differential	2
P10	°F	37	set temperature chill end temperature (with reference to the needle probe)	37
P11	°F	37	set temperature freeze end temperature (with reference to the needle probe)	0
P12	°F	46	temperature at which the hard chill switches from the first step to the second (with reference to the needle probe)	46
P13	°F	99	temperature above which it is not possible to start a set-temperature operational cycle (with reference to the needle probe)	99
P14	°F	9	needle probe and cabinet temperature differential for verification of correct needle probe insertion 0 = the test will not be performed	9
P15	sec	60	duration of the second test to check correct needle probe insertion; see also P14	60
P16	min	90	maximum set temperature chill duration; also timed chill duration	90
P17	min	90	maximum set temperature freeze duration; also timed freeze duration	240
P18	min	45	first hard timed chill step duration	45
GROUP	-	-	COMPRESSOR PROTECTIONS	-
P19	min	0	compressor delay from device power on (from restoration of power)	0
P20	min	0	minimum elapsed time period between two consecutive compressor start-up operations	0
P21	min	0	minimum compressor shut-down time	0
GROUP	-	-	DEFROSTING	-
P22	-	1	defrost type 0 = electric (defrost on relay) 1 = hot gas (defrost compressor and relay on) 2 = air (evaporator fan on)	1
P23	°F	46	defrost end temperature (with reference to the evaporator probe)	46
P24	min	10	maximum defrost duration	10
P25	hour	6	defrost interval during storage; see also P26 0 = intermittent defrosting will never be activated (only the first will be activated)	6

Service Menu – Configuration Parameters (continued)

CODE	U.O.M.	GBC	DESCRIPTION	GBF
P26	min	1	first defrost delay from start of storage; see also P25	1
P27	-	1	defrosting at start of chilling and freezing 1 = YES	1
P28	min	2	drip-drain duration	2
P29	-	0	resetting of compressor protections at start of defrosting (only if P22 = 1) 1 = YES	0
P30	sec	30	elapsed time between the defrost request and switching on the compressor (only if P22 = 1 and providing that the compressor is off when the defrost is requested); see P31 (7) (8)also	30
P31	sec	0	elapsed time between the defrost request and activation of the solenoid valve (only if P22 = 1 and on condition that the compressor is off when defrosting is requested); see also P30	0
GROUP	-	-	EVAPORATOR FAN	-
P32	°F	37	temperature above which the evaporator fan is switched off during storage (with reference to the evaporator probe)	37
P33	°F	2	P32 differential	2
P34	-	0	evaporator fan activity during defrosting (only if P22 = 0 or 1) 0 = on 1 = off	0
P35	min	3	evaporator stop time after dripping	3
P36	°F	99	temperature above which the evaporator fan is switched off (with reference to the cabinet probe)	99
P37	-	1	effect caused by activation of microport input on evaporator fan 0 = no effect 1 = the evaporator fan will be switched off	1
GROUP	-	-	DIGITAL INPUTS	-
P38	-	1	microport input contact type 0 = NA (input active with contact closed) 1 = NC (input active with contact open)	1
P39	min	0	micro port input alarm delay	0
P40	-	1	high pressure input contact type 0 = NA (input active with contact closed) 1 = NC (input active with contact open)	1
P41	min	120	high pressure input alarm delay	120
P42	-	0	low pressure input contact type 0 = NA (input active with contact closed) 1 = NC (input active with contact open)	0
P43	min	0	low pressure input alarm delay	0
P44	-	0	compressor thermal protection input contact type 0 = NA (input active with contact closed) 1 = NC (input active with contact open)	0

Service Menu – Configuration Parameters (continued)

CODE	U.O.M.	GBC	DESCRIPTION	GBF
P45	min	0	compressor thermal protection input alarm delay	0
GROUP	-	-	CABINET STERILISATION	-
P46	min	5	UV light on duration (duration of cabinet sterilisation)	5
GROUP	-	-	NEEDLE PROBE HEATING	-
P47	°F	99	needle probe heating end temperature (with reference to the needle probe)	99
P48	sec	15	maximum duration of needle probe heating	15
GROUP	-	-	DOOR ELEMENTS	-
P49	°F	41	the temperature, below which the door elements are switched on (with reference to the cabinet probe)	41
P50	°F	4	P49 differential	4
GROUP	-	-	CONDENSER FAN	-
P51	-	1	condenser fan activity in the absence of the condenser probe (P61 = 0) 0 = in parallel with compressor 1 = on	1
P52	°F	68	the temperature below which the condenser fan is switched off in the presence of the condenser probe (P61 = 1) and on condition that the compressor is on (with reference to the condenser probe); see also P54	68
P53	°F	9	P52 differential	9
P54	sec	30	condenser fan switch off delay on switching off the compressor in the presence of the condenser probe (P61 = 1); see also P52	30
GROUP	-	-	MISCELLANEOUS	-
P55	sec	3	chill and freeze cycle completion buzzer duration	3
P56	sec	15	maximum buzzer duration during an alarm state	15
P57	sec	10	elapsed time between switching on the compressor and pump down valve activation (pump down in power up); also elapsed time between deactivation of the pump down valve and switching off the compressor (pump down in power down)	10
P58	-	0	defrost parameter units of measurement 0 = P25 h, P24, P26, P28 and P35 min 1 = P25 min, P24, P26, P28 and P35 s	0
P59	-	0	reserved	0
P60	-	0	probe type 0 = NTC 1 = PTC	0
P61	-	0	condenser probe enabling 1 = YES	0

Service Menu – Configuration Parameters (continued)

CODE	U.O.M.	GBC	DESCRIPTION	GBF
GROUP	-	-	CONDENSER TEMPERATURE ALARMS	-
P62	°F	99	the temperature above which the condenser temperature alarm is activated (with reference to the condenser probe)	99
P63	°F	18	P62 differential	18
GROUP	-	-	CABINET TEMPERATURE ALARMS	-
P64	°F	-7	temperature below which the minimum temperature alarm is activated during post-chill storage, with relation to P7, i.e. "P7 + P64" (with reference to the cabinet probe) 0 = no alarm	-7
P65	°F	7	temperature above which the maximum temperature alarm is activated during post-chill storage, with relation to P7, i.e. "P7 + P65" (with reference to the cabinet probe) 0 = no alarm	7
P66	°F	0	temperature below which the minimum temperature alarm is activated during post-freezing storage, with relation to P8, i.e. "P8 + P66" (with reference to the cabinet probe) 0 = no alarm	-7
P67	°F	0	temperature above which the maximum temperature alarm is activated during post-freezing storage, with relation to P8, i.e. "P8 + P67" (with reference to the cabinet probe) 0 = no alarm	7
P68	°F	0	P64, P65, P66 and P67 differential	0
P69	min	25	storage operation start-up temperature alarm delay	25
P70	min	10	temperature alarm delay	10
GROUP	-	-	DATA PRINTING	-
P71	-	0	enable printing 1 = YES	0
P72	min	5	print interval	5
P73	-	0	HACCP alarm list deletion 1 = YES	0
P74	-	2	Baud rate 0=2400 1=4800 2=9600 3=19200	2
P75	-	2	Bit polarity 0=no polarity 1=even 2=odd	2
P76	-	1	Board address	1

Service Menu – Configuration Parameters (continued)

Temperature Probe Display

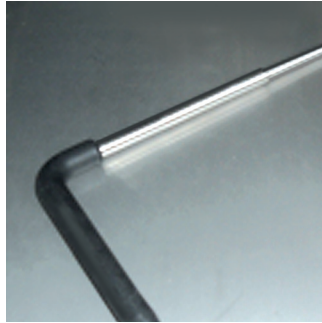

To check the reading of the unit's temperature sensing probes, first make sure the unit is in the OFF mode.

1. Press the NEEDLE PROBE key and the DOWN arrow key together and hold for five (5) seconds.
2. To scroll through the reading use the UP or DOWN arrow key.

DISPLAY	PROBE
Pr1	Cabinet Probe
Pr2	Needle Probe
Pr3	Evaporator Probe

Valuable information can be obtained by checking the evaporator probe when the unit is struggling to reach the cabinet temperature setpoint, (i.e. -40°F). This may indicate that the evaporator coil is not being supplied with sufficient refrigerant.

With a cabinet setpoint of -40°F the actual evaporator temperature is approximately -49°F at 0 PSIG. In this case, the controller evaporator probe reading **MUST BE** at least -42°F, which is the minimum readable temperature.

HACCP Printer

Blast Chillers can be ordered with an optional printer, or one can be installed as a retrofit. The printer has its own power supply connection (110VAC – 240VAC 50/60 Hz). The printer is connected to the Main Board at the second RS 485 connection port (shown).

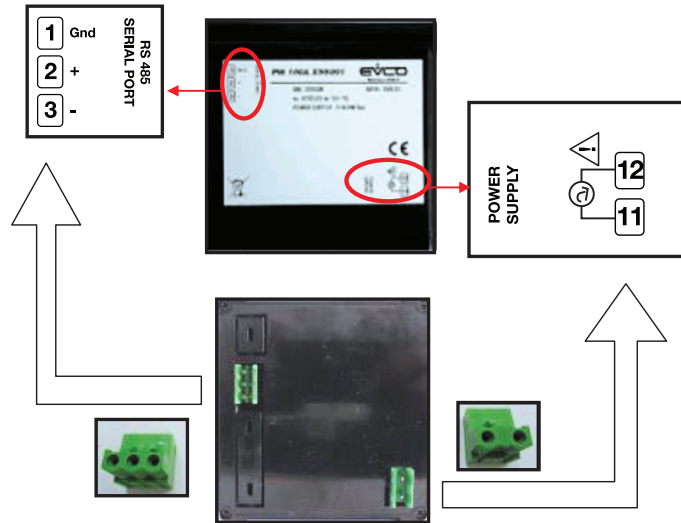

A belden shielded cable (3 wires) must be used.

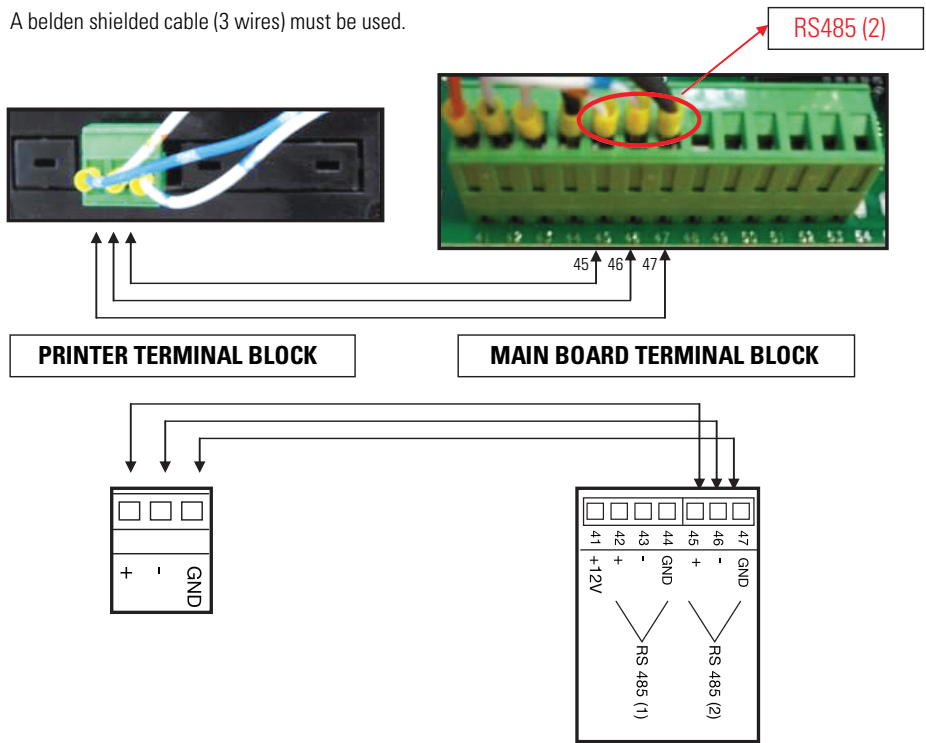

HACCP Printer (continued)

1. Connect the printer to the Main Board using coaxial shielded cables.
2. The main controller must be set to recognize the printer and enable communication. Set configuration parameter P71 to 1 to enable the printer port on the Main Board. In addition, ensure that the following parameters are set as shown:

P76 – 1

P75 – 2

An LED on the printer will indicate its status: RED = ON.

4. Press the feed key to output blank paper in either ON or OFF status.

Printing Alarm List

To print the alarm list, the controller must be in the OFF mode.

1. Press the PROGRAM key for five (5) seconds.

If the printer communication has been enabled, the first display shown is "Prt".

2. To print the alarm code, press the PROGRAM key.
3. To exit from printing, press either the UP or DOWN arrow key and the alarm list will be shown in the display.

```

Dur:      0 Min
Pr1:     28°C
Start:   07/06/2012  14:52
Nr. 10   E1

Dur:      0 Min
Pr1:     ---
Start:   07/06/2012  14:51
Nr. 9    E0

Dur:      0 Min
Pr1:     -1°C
Start:   07/06/2012  14:40
Nr. 8    HP
  
```

The controller will only save the previous 10 alarms.

Printed codes will be as shown:

- Alarm duration
- Max/Min Temperature
- Date /Time
- Alarm Code

```

10:38   29°C   29°C
10:37   29°C   29°C
10:36   29°C   29°C
10:35   29°C   29°C

10:34   29°C   29°C
START
Pr1     Pr2
T***
08/06/2012
***
****
**
  
```

Printing Cycle Data

With the HACCP printer, it is also possible to print data history related to the freezing and chilling cycles.

If the printer is left ON and a cycle is started, the data will be captured. Data capture frequency is set in Parameter P72 (example: If P72 = 1, device will print every minute) and give the following information:

- Type of cycle
- Start date and time
- Time, Cabinet and Needle Probe temperatures (each capture line)

HACCP Printer (continued)

Legend – Type of cycle:

Cycle code	Description
T*	Needle probe soft chilling
T***	Needle probe freezing
T>>>*	Needle probe hard chilling
t*	Time soft chilling
t***	Time freezing
t>>>*	Time hard chilling
P1.....99	Programmed cycle

Replacing the printer paper

1. Press on the printer front cover as indicated. The cover will open allowing access to the paper roll.



2. Pull the paper roll to one side to remove.

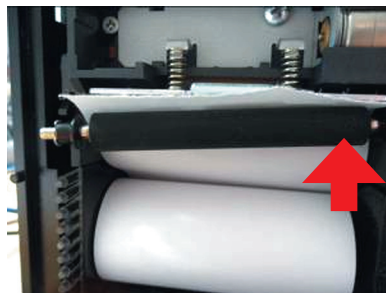

3. Insert the new paper roll.

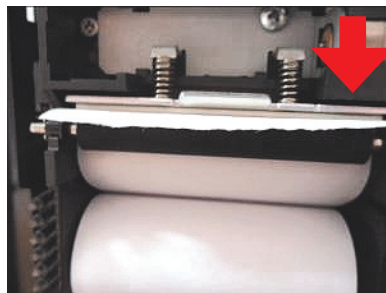

4. Thread the paper between the rollers.
5. Reset roller and close the cover.

Section 2 Troubleshooting

WARNING: Before performing any service that involves electrical connection or disconnection and/or exposure to electrical components, always follow the Electrical LOCKOUT/TAGOUT Procedure. Disconnect all circuits. Failure to comply can cause property damage, injury or death.

If, upon first inspection, the cause of a problem is not obvious, a more thorough troubleshooting may be necessary. The unit may need to be unplugged or otherwise removed from the power supply so the internal components can be tested.

Probes

The Blast Chiller is equipped with several temperature sensing probes. These probes are Negative Temperature Coefficient (NTC) thermoset sensors. The chamber and evaporator probes have the same configuration.



NTC Probe



Bulb



Probe Measuring



NTC Needle Probe Types

The needle probe has a different sensing element. Both types of probes have the same resistance to temperature correlation.

Checking the Probes

When a Probe alarm occurs, it means there is something wrong with the sensor reading. The problem may be in either the sensor wires or the sensor itself.

Probe alarms Er0, Er1, and Er3 are commonly due to an interrupted (open) circuit in the wires.

The cause may be a short to the chassis or the two leads shorting together.

Probes (continued)

To find the cause of the alarm, disconnect the indicated probe and check the resistance between the two wires.

If the Ohm reading is 0	Probe circuit is shorted between the two wires	Replace the probe
Ohm reading is infinity, ∞	Probe is open	Replace the probe
Reading matches the resistance chart at a known temperature	Probe is good	Another problem is the cause
Reading is not 0 or ∞ and does not match the resistance chart	Probe is out of range	Replace the probe

If none of these choices is the case:

Ohm out each wire to the chassis. If the reading is 0 or anything less than ∞ , the probe is shorted to the chassis and must be replaced.

Note: A spare probe can be used in place of the suspected one. If the alarm continues, the problem is something other than the probe.

The problem could also be in the probe connection to the Main Board.

Check for corrosion, water, loose or missing connections.

The problem could also be a result of an internal failure on the Main Board. If all previous probe troubleshooting has not found the problem and the alarm still occurs, replace the Main Board.

Probe Resistance Graph and Chart

Resistance Graph

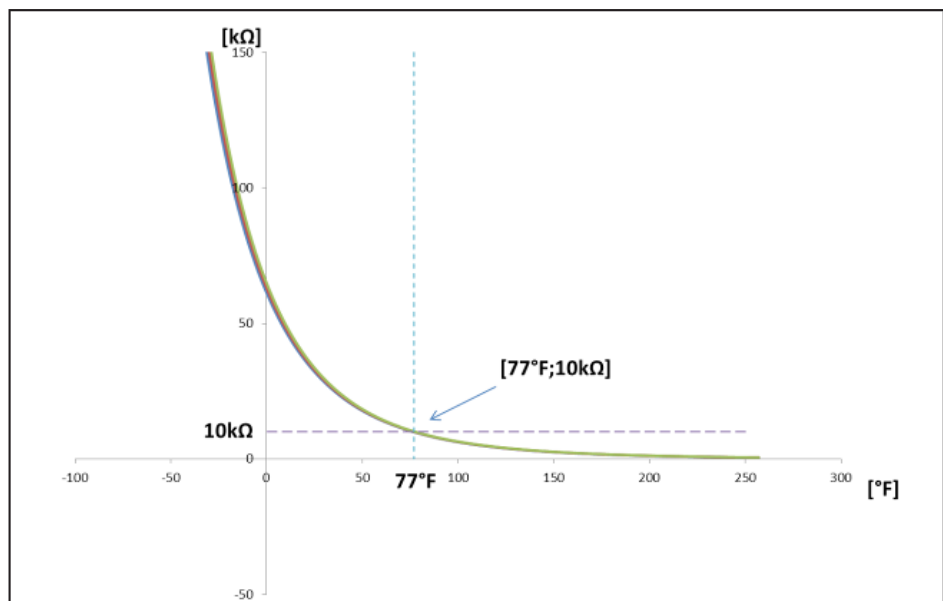

Probes (continued)

Resistance Chart

T (°F)	R (kΩ) low	R (kΩ) mid	R (kΩ) high
-40.0	197.1	205.2	213.6
-38.2	186.3	193.8	201.6
-36.4	176.1	183.1	190.4
-34.6	166.5	173.1	179.8
-32.8	157.5	163.6	170.0
-31.0	149.1	154.8	160.7
-29.2	141.2	146.5	152.0
-27.4	133.7	138.7	143.8
-25.6	126.7	131.3	136.1
-23.8	120.1	124.4	128.9
-22.0	113.9	117.9	122.1
-20.2	108.0	111.8	115.7
-18.4	102.5	106.0	109.7
-16.6	97.34	100.6	104.0
-14.8	92.45	95.51	98.67
-13.0	87.83	90.69	93.64
-11.2	83.47	86.15	88.91
-9.4	79.35	81.86	84.43
-7.6	75.47	77.81	80.22
-5.8	71.79	73.99	76.24
-4.0	68.32	70.37	72.48
-2.2	65.04	66.96	68.93
-0.4	61.94	63.74	65.58
1.4	59.01	60.69	62.41
3.2	56.23	57.8	59.41
5.0	53.6	55.07	56.58
6.8	51.11	52.49	53.9
8.6	48.75	50.04	51.36
10.4	46.51	47.72	48.96
12.2	44.39	45.52	46.68
14.0	42.38	43.44	44.52
15.8	40.47	41.46	42.48
17.6	38.66	39.59	40.54
19.4	36.94	37.81	38.7
21.2	35.31	36.13	36.96
23.0	33.76	34.53	35.31
24.8	32.29	33.0	33.73
26.6	30.89	31.56	32.24
28.4	29.56	30.19	30.83
30.2	28.29	28.88	29.48
32.0	27.09	27.64	28.2

T (°F)	R (kΩ) low	R (kΩ) mid	R (kΩ) high
33.8	25.94	26.46	26.98
35.6	24.85	25.33	25.83
37.4	23.81	24.26	24.72
39.2	22.82	23.24	23.68
41.0	21.88	22.27	22.68
42.8	20.98	21.35	21.73
44.6	20.12	20.47	20.82
46.4	19.3	19.63	19.96
48.2	18.52	18.83	19.14
50.0	17.78	18.06	18.35
51.8	17.07	17.34	17.61
53.6	16.39	16.64	16.89
55.4	15.75	15.98	16.22
57.2	15.13	15.35	15.57
59.0	14.54	14.74	14.95
60.8	13.98	14.17	14.36
62.6	13.44	13.62	13.79
64.4	12.92	13.09	13.26
66.2	12.43	12.59	12.74
68.0	11.96	12.11	12.25
69.8	11.51	11.65	11.78
71.6	11.08	11.21	11.33
73.4	10.67	10.79	10.9
75.2	10.28	10.38	10.49
77.0	9.9	10.0	10.1
78.8	9.532	9.632	9.732
80.6	9.18	9.279	9.379
82.4	8.843	8.942	9.041
84.2	8.52	8.619	8.718
86.0	8.21	8.309	8.407
87.8	7.914	8.012	8.11
89.6	7.63	7.727	7.825
91.4	7.358	7.454	7.551
93.2	7.097	7.192	7.288
95.0	6.847	6.941	7.036
96.8	6.606	6.7	6.794
98.6	6.376	6.468	6.562
100.4	6.155	6.246	6.338
102.2	5.942	6.033	6.124
104.0	5.738	5.828	5.918
105.8	5.542	5.631	5.72

Probes (continued)

T (°F)	R (kΩ) low	R (kΩ) mid	R (kΩ) high
107.6	5.354	5.441	5.529
109.4	5.173	5.259	5.346
111.2	4.999	5.084	5.17
113.0	4.832	4.916	5.0
114.8	4.671	4.754	4.837
116.6	4.517	4.598	4.68
118.4	4.368	4.448	4.529
120.2	4.225	4.304	4.383
122.0	4.087	4.165	4.243
123.8	3.954	4.031	4.108
127.4	3.704	3.778	3.853
129.2	3.585	3.658	3.732
131.0	3.471	3.543	3.616
132.8	3.362	3.432	3.504
134.6	3.256	3.325	3.396
136.4	3.154	3.222	3.291
138.2	3.056	3.123	3.191
140.0	2.961	3.027	3.094
141.8	2.869	2.934	3.0
143.6	2.781	2.845	2.91
145.4	2.696	2.759	2.823
147.2	2.614	2.676	2.738
149.0	2.535	2.595	2.657
150.8	2.459	2.518	2.578
152.6	2.385	2.443	2.503
154.4	2.313	2.371	2.429
156.2	2.245	2.301	2.358
158.0	2.178	2.233	2.29
159.8	2.114	2.168	2.224
161.6	2.052	2.105	2.16
163.4	1.992	2.045	2.098
165.2	1.935	1.986	2.039
167.0	1.879	1.929	1.981
168.8	1.825	1.874	1.925
170.6	1.773	1.821	1.871
172.4	1.722	1.77	1.819
174.2	1.673	1.72	1.768
176.0	1.626	1.672	1.719
177.8	1.58	1.625	1.672
179.6	1.535	1.58	1.625
181.4	1.492	1.536	1.58
183.2	1.45	1.493	1.537

T (°F)	R (kΩ) low	R (kΩ) mid	R (kΩ) high
185.0	1.409	1.451	1.494
186.8	1.37	1.411	1.453
188.6	1.331	1.372	1.413
190.4	1.294	1.334	1.374
192.2	1.258	1.297	1.337
194.0	1.222	1.261	1.3
194.0	1.222	1.261	1.3
195.8	1.188	1.226	1.264
197.6	1.155	1.192	1.23
199.4	1.123	1.159	1.196
201.2	1.092	1.127	1.164
203.0	1.062	1.097	1.132
204.8	1.033	1.067	1.102
206.6	1.004	1.038	1.072
208.4	0.977	1.01	1.044
210.2	0.9505	0.9826	1.016
212.0	0.9247	0.9563	0.9888
213.8	0.8998	0.9307	0.9626
215.6	0.8756	0.9059	0.9372
217.4	0.852	0.8818	0.9125
219.2	0.8292	0.8584	0.8885
221.0	0.8071	0.8357	0.8653
222.8	0.7856	0.8136	0.8427
224.6	0.7647	0.7922	0.8207
226.4	0.7444	0.7715	0.7994
228.2	0.7248	0.7513	0.7787
230.0	0.7057	0.7317	0.7586
231.8	0.6872	0.7127	0.7391
233.6	0.6692	0.6943	0.7202
235.4	0.6518	0.6764	0.7018
237.2	0.6349	0.659	0.6839
239.0	0.6185	0.6421	0.6666
240.8	0.6026	0.6258	0.6498
242.6	0.5871	0.6099	0.6334
244.4	0.5721	0.5945	0.6176
246.2	0.5576	0.5795	0.6022
248.0	0.5435	0.565	0.5873
249.8	0.5298	0.5509	0.5728
251.6	0.5165	0.5372	0.5587
253.4	0.5037	0.524	0.5451
255.2	0.4912	0.5111	0.5318
257.0	0.4791	0.4986	0.5189

Door Switch

The Blast Chiller is equipped with a magnetic door switch. Opening the door is detected by a magnetic sensor. When the door is closed the sensor is activated by a magnet built into the door. There are two magnets in each door, one at the top and one at the bottom. This allows the door to be reversed.

Foamed magnet

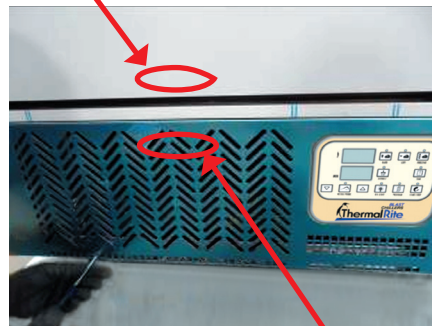

Sensor bracket

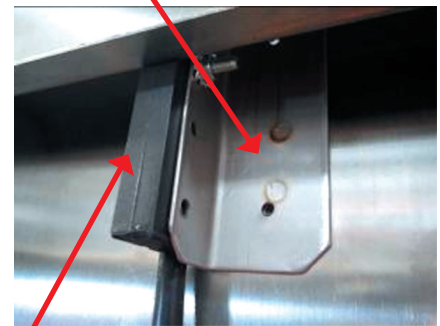

Magnet sensor (behind front panel)

When the door is closed the magnet closes a reed switch in the sensor. This closes a circuit from the Main Board at terminals 48 & 49. When the door opens, the reed switch opens and the circuit to the Main Board is interrupted. An alarm occurs and "d-r" is shown in the display.

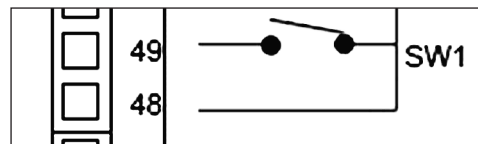

Checking the Door Switch

If the magnetic sensor is faulty or if the wires are broken or shorted, the display will show "d-r" continuously. To check the switch, disconnect the wires from the Main Board at terminals 48 & 49. Ohm out the switch between the two wires. The switch should be closed when a magnet is present and open when it is not. If the switch tests OK, check for corroded, loose or missing connections on the terminals. If no problem is found in the switch or wires, replace the Main Board.

Pressure Switch

There is a pressure regulating switch installed to prevent compressor failures or improper operation due to high discharge pressure or low suction pressure.

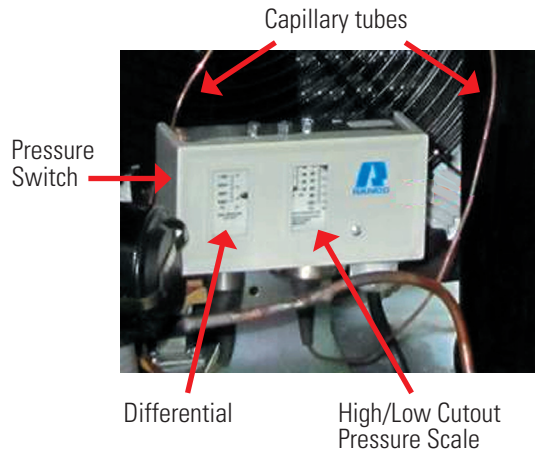

Pressure Switch Working Principles

The pressure switch has normally closed contacts that will open if the High or Low pressure limits are exceeded. The switch is connected to the Main Board at terminals 48 & 50 (48 is a shared connection with the door switch). When the pressure switch opens from either a high or low pressure condition, the display will show the error code "hP".

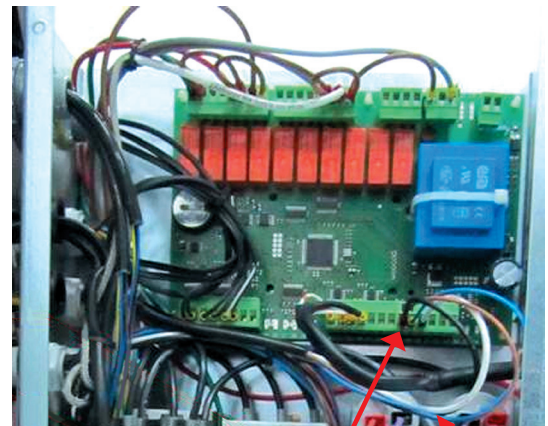
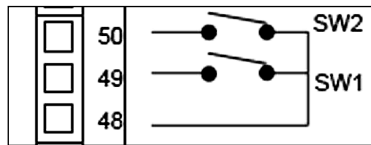

Switch cables

Once the pressures return to the normal range, the pressure switch will reset automatically.

Pressure Switch Factory Setting

The factory setting for the pressure switch is as follows. Do not change these settings!

- High Pressure Limit – 420 psig
- Low Pressure Limit – 0 psig
- Differential – 10 psig

Door Frame Heater

Both Shock Freezer and Blast Chiller units come equipped with a door frame heater to prevent frost buildup on the door gasket. The heater may be either 115V or 220V depending on the model/rating. For 220V 3-phase units (or 220V single-phase units with no neutral), the door frame heater is connected between two live mains. The heater runs around the frame, under a plastic strip cover. Electrical connections run through the lower cabinet panel to the electrical component box.

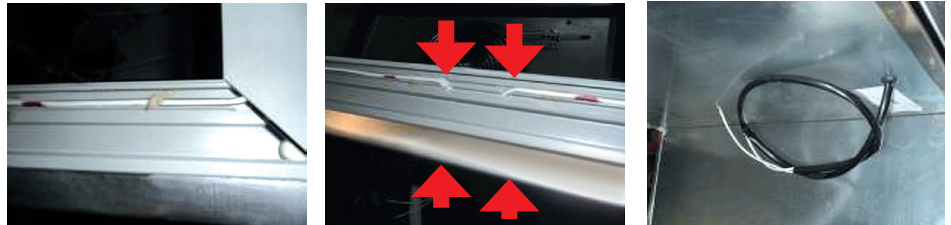

Heater Cable Specifications

	115V	220V
Length	7.8 Ft.	(Heated) 6.5 ft.
Resistance	1.4 k Ω	2.4 k Ω
Current	80 mA	90 mA

Main Board

Each unit is equipped with a Main Board where the electrical components are connected. In remote units, this board is located in the condensing unit. The board has 10 outputs (10 relays) as shown below.

The relays control various components, shown in the table below:

RELAY	RELATED COMPONENT
K1 (Load 1)	Compressor Contactor Coil
K2 (Load 2)	Pump-down Valve
K3 (Load 3)	Evaporator Fan Motor Contactor Coil
K4 (Load 4)	Defrost Valve
K5 (Load 5)	UV Lamp
K6 (Load 6)	Heated Needle Probe
K7 (Load 7)	Condenser Fan Motor Contactor Coil
K8 (Load 8)	Door Frame Heater
K9 (Load 9)	Light
K10 (Load 10)	Alarm

Depending on the unit's voltage rating, each load is directly connected to either L1 or Neutral. L2 is switched by the dedicated relay.

Main Board (continued)

Testing Relay Outputs

When a particular component is not working, the component itself may not be faulty. Knowing the logic and outputs of the Main Board will allow you to troubleshoot the root cause. The relays will activate and deactivate according to the logic sequences of the controller.

To test an output, disconnect the input line to the relay and the output line to the component.

For example: To check K10, disconnect the wires on terminals 19 and 20 on the Main Board.

Ohm out the relay between those terminals. If the contact opens and closes appropriately with the logic of the board, it is working correctly. If a relay's contacts remain open or closed constantly, the relay has failed and the Main Board must be replaced.

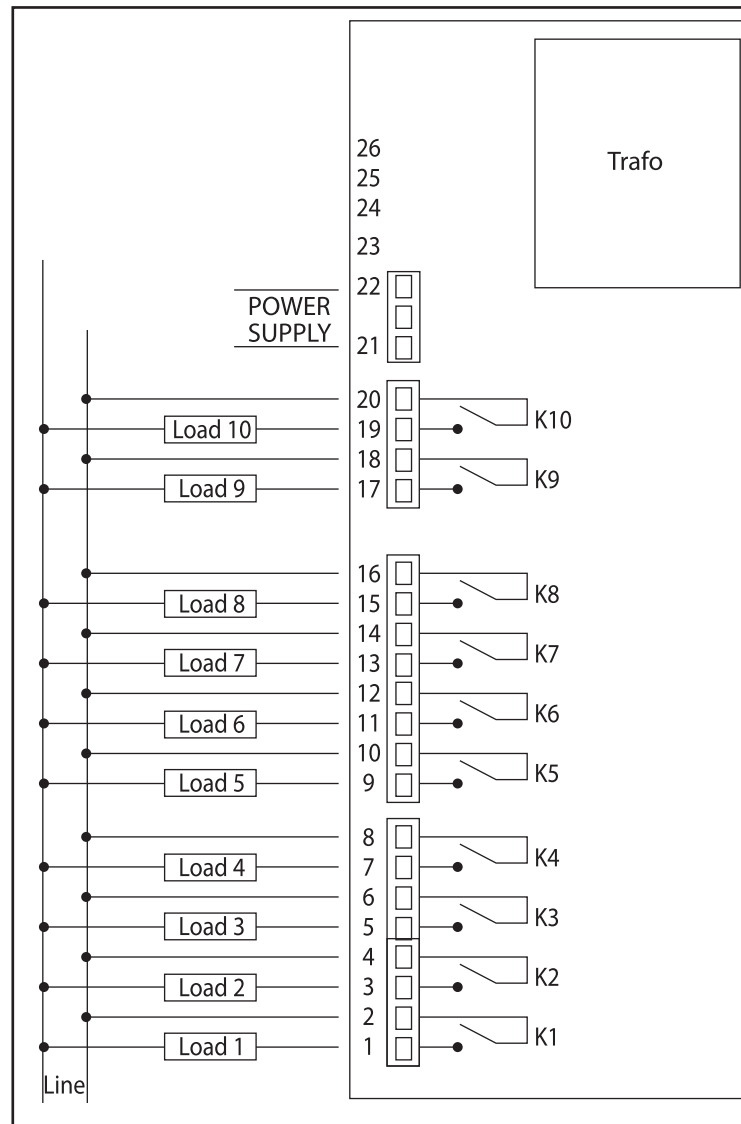

Keypad

The Keypad is the user interface for the unit and is connected directly to the Main Board.

Connection on relay board

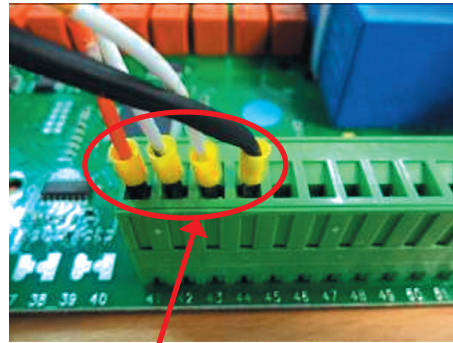

RS485(1)

Connection on keypad

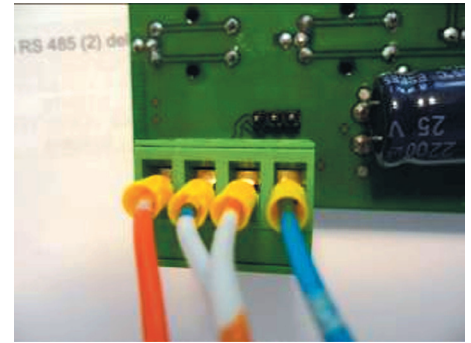

Keypad Troubleshooting

Problems with the Keypad may include:

Ground Connection Missing	Display flashes and dims
Negative (-) connection missing	Display may work without specific alarm
Positive (+) connection missing	Error Code "Err" is displayed
12V Connection missing	Display does not light.
Keypad faulty	All connections are present but display does not work.

Refrigerant Pressure Checks

High or Low refrigerant pressure levels are dependent on:

- Ambient temperature
- Heat load in the cabinet (Full or Empty)
- Status of the cycle (hot food, frozen food etc.)
- Cabinet temperature
- TX valve regulation
- Evaporator coil air flow
- Condenser coil air flow

Checking the High and Low pressures on the unit alone cannot determine if the unit is operating correctly. Careful analysis, based on the conditions listed above, is necessary to properly diagnose a problem.

For example: Checking the suction pressure results in a reading of 0.1 psig. This could be the correct pressure if the cabinet temperature is at the minimum (-40°F) and the evaporator temperature is at -49°F.

Refrigerant Pressure Checks

If this is not the case, the evaporator may not be getting sufficient refrigerant and the actual evaporator temperature could be much higher than -49°F.

It is not recommended to base any troubleshooting conclusions solely on the pressure readings.

Suction Pressure: 1.5 – 2 psig

This pressure should be measured when the cabinet temperature is at -40°F with the compressor running.

Discharge Pressure: 230 psig

This pressure can vary greatly and can reach up to 360 psig, depending on the ambient temperature and heat load inside the cabinet. Very high discharge pressures can cause the pressure switch to signal an alarm.

Section 3 Service and Repair Procedures

WARNING: Before performing any service that involves electrical connection or disconnection and/or exposure to electrical components, always follow the Electrical LOCKOUT/TAGOUT Procedure. Disconnect all circuits. Failure to comply can cause property damage, injury or death.

Removing the Front Panel

Models from GBC30SG to GBF171-132S

1. Insert a screwdriver through the square access holes at the bottom of the panel and remove the two screws.

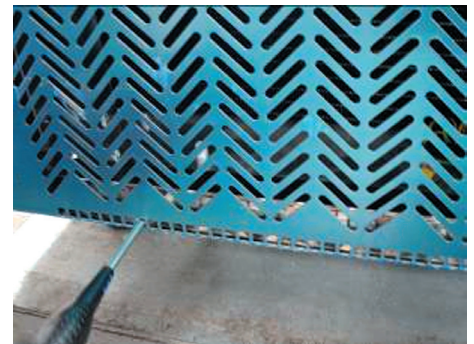
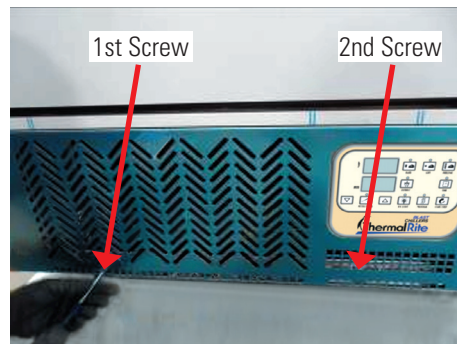

2. The panel is attached at the top by two pins on the left and right.
Pull the panel out from the bottom and pull it down so the pins are clear of the holes.

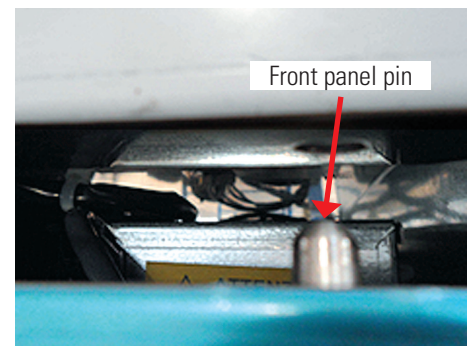

Removing the Front Panel (continued)

Model GBF15-11S

1. Open the door.
2. Remove the two screws on the door frame side of the panel.

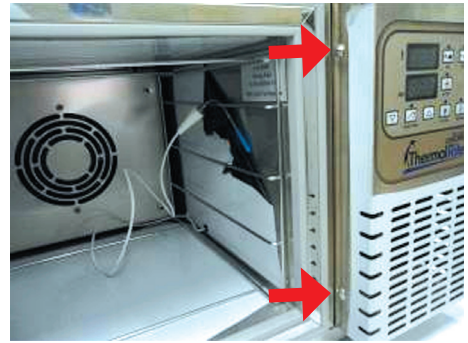
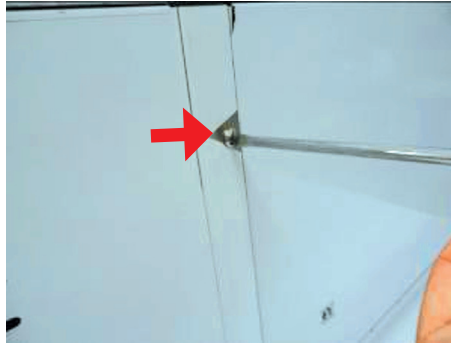

3. Remove the panel to access the condenser coil, keypad and door switch.

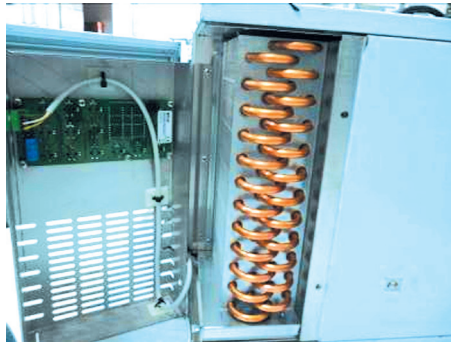

Reversing the Door Swing

The door on each model can be reversed so that it is hinged on the right or left.

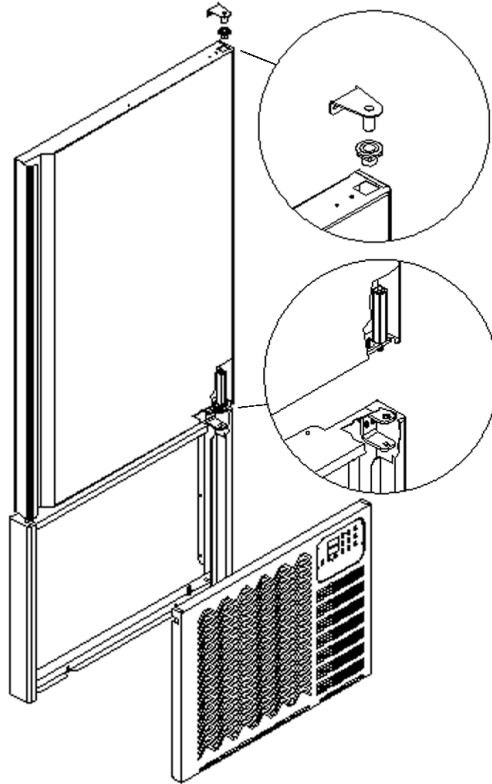

1. Remove the front panel and look for the C-shaped bracket under the right side of the door.

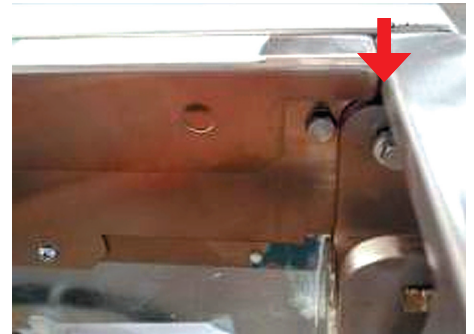
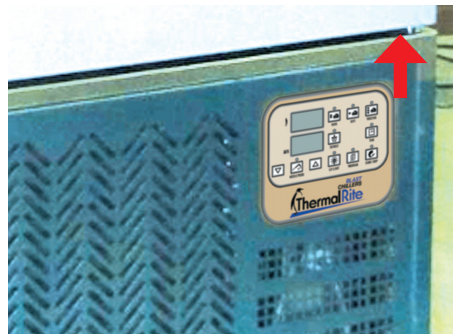

2. Unscrew the bracket and take it off by removing the hinge pin from the square hole.



Reversing the Door Swing (continued)

3. Unscrew the upper hinge.



4. Lift the door up, pull it out and set it aside.

Bottom hinge

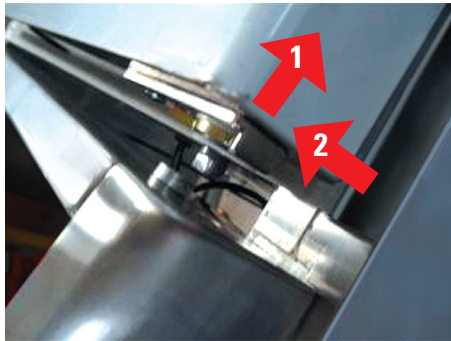

Upper hinge

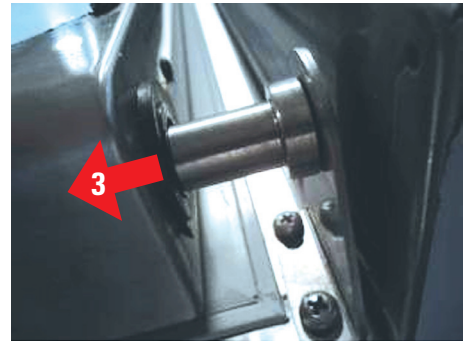

5. Remove the lower hinge pin and plastic bushing from the door.

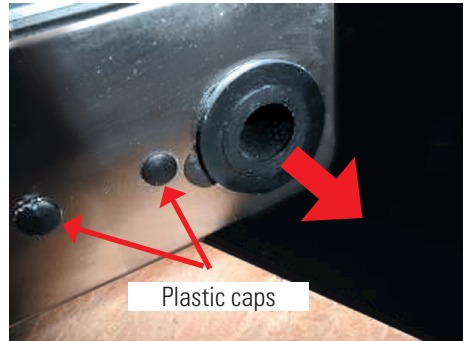

6. Remove the foam insulation from the upper door hole.

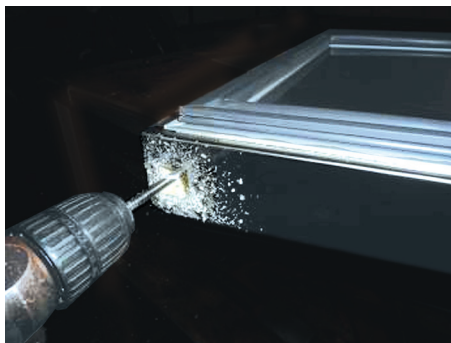

Reversing the Door Swing (continued)

7. Move the lower hinge and upper plastic bushing to the opposite ends of the door.

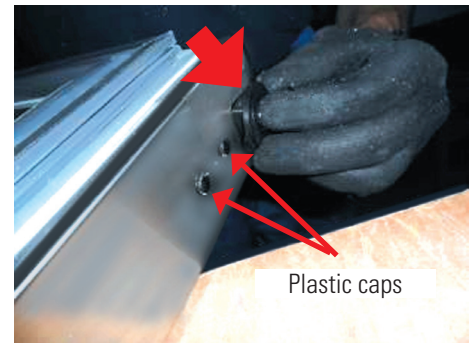

8. Place the plastic filler caps in the screw holes that previously held the lower hinge.
9. Move the locking pin by fitting it in hole on the opposite side of the frame panel. Fit pins and nylon bushings as shown.

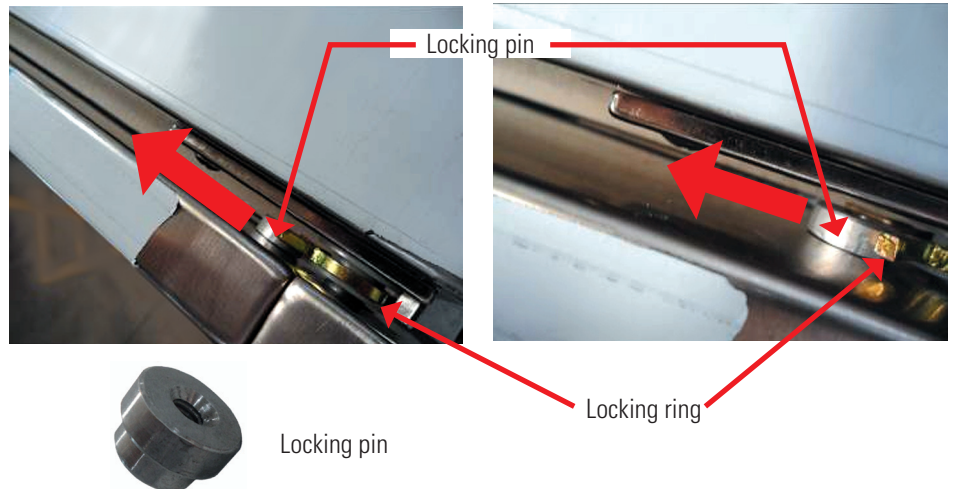

10. Move the C-shaped bracket from the opposite side and attach with the screws but do not tighten.

Pay special attention to the positioning of the C-shaped bracket.

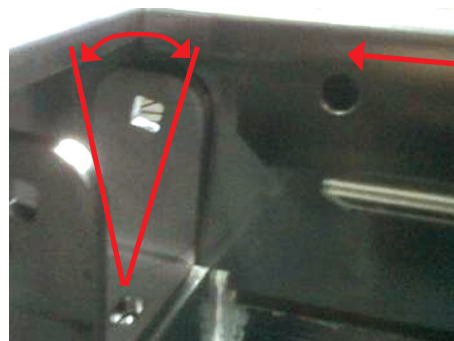

Reversing the Door Swing (continued)

11. The correct angle of the square hole will allow proper loading of the hinge spring when the door is closed, providing better sealing pressure on the gasket.
12. Turn the door over and fit the upper hinge.
13. Fit the bottom hinge pin into the square hole of the bracket.
14. Tighten the screws on both upper and lower hinges.
15. Test the door for proper operation and correct seal.
16. Replace the front panel.

Accessing the Condensing Unit (Self-Contained Models)

Models from GBC39S to GBF171-132S

1. Remove the rear grid by unscrewing corner screws.

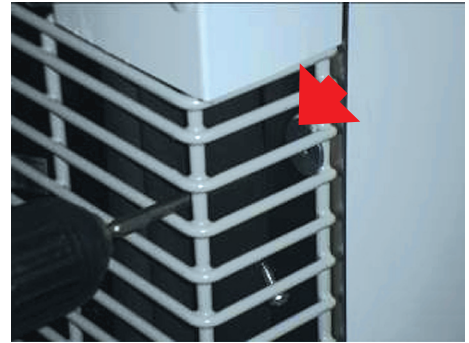

2. Remove the front panel.



Accessing the Condensing Unit (Self-Contained Models)

3. Unscrew the left and right side bolts from the compressor base plate at the sides of the condenser.

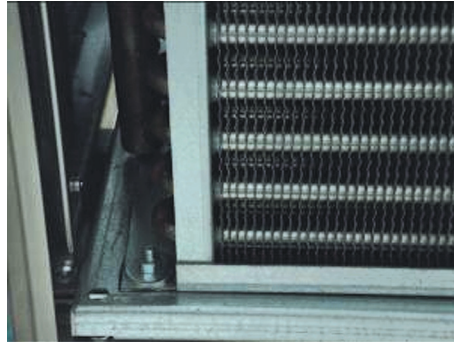

4. Disconnect the keypad wires.

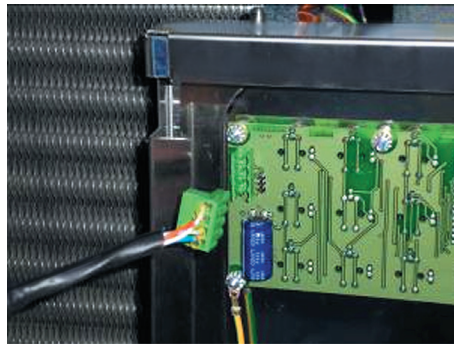

5. Loosen or cut the cable ties to extend the length to make clearance to slide out the compressor base.



6. Cut the ties that fasten the drain duct.

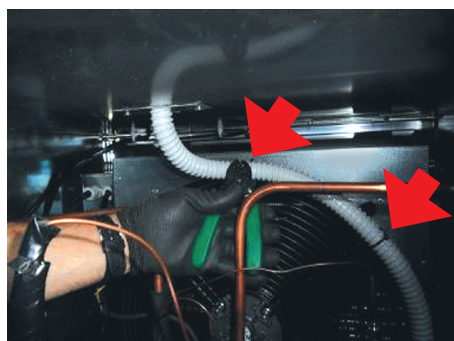

Accessing the Condensing Unit (Self-Contained Models)

7. Move the drain duct so that it will not interfere with sliding out the compressor base plate.

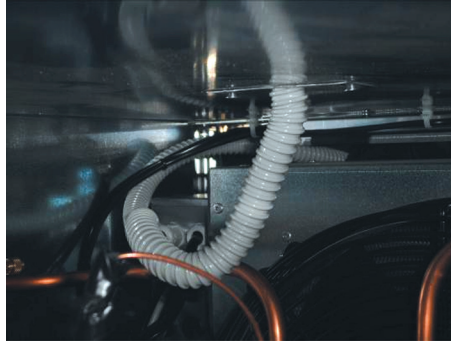

8. Remove the caps from the corner stainless steel angles.

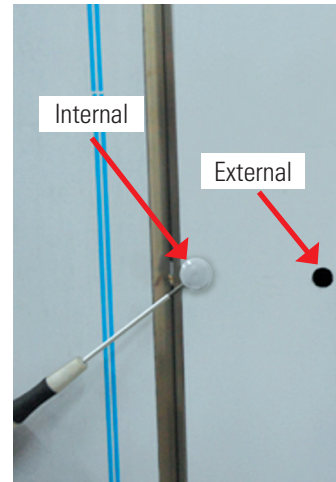
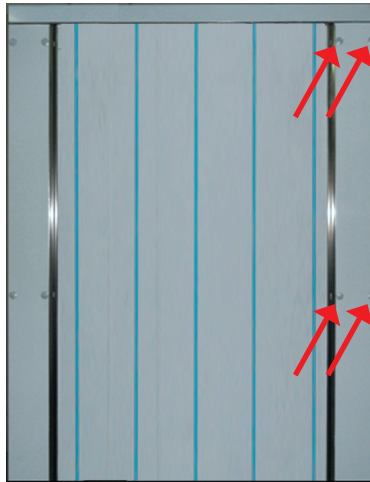

9. With the caps removed, loosen the inner screws. Do not remove them. This is done at a 45° angle to the back panel.

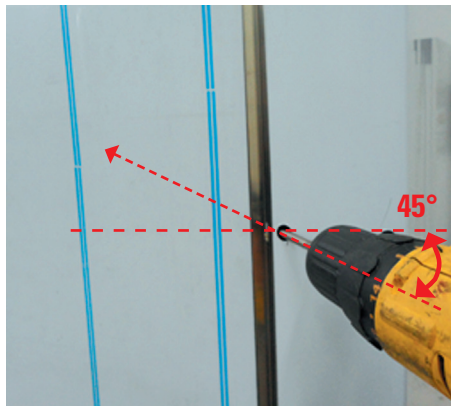

Accessing the Condensing Unit (Self-Contained Models)

10. Unscrew the outer screws and remove them completely.

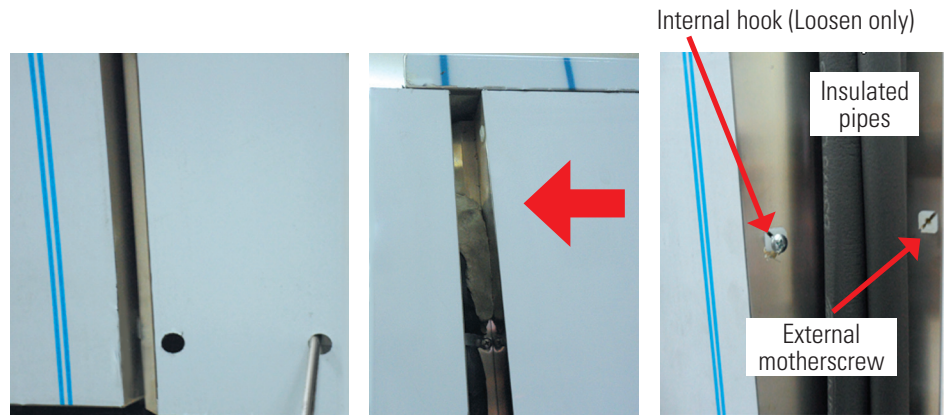

11. The cover can now be removed.

12. Unscrew the right and left side bolts on the compressor base plate.

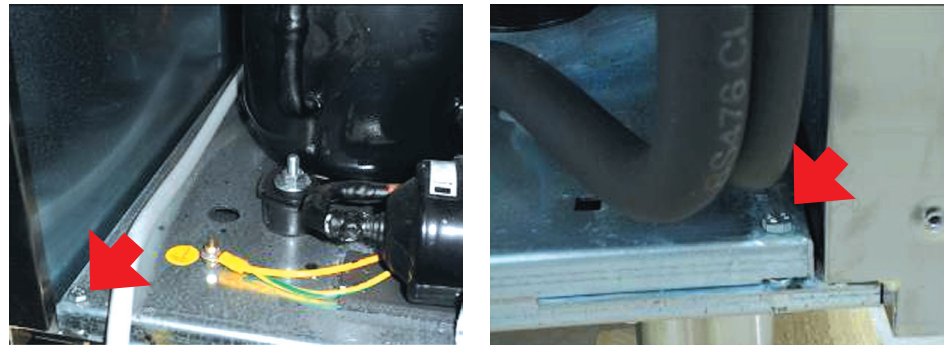

13. Lift the front edge of the base plate by pushing it forward to clear.



Accessing the Condensing Unit (Self-Contained Models)

14. From the rear, slide the base plate out as needed.

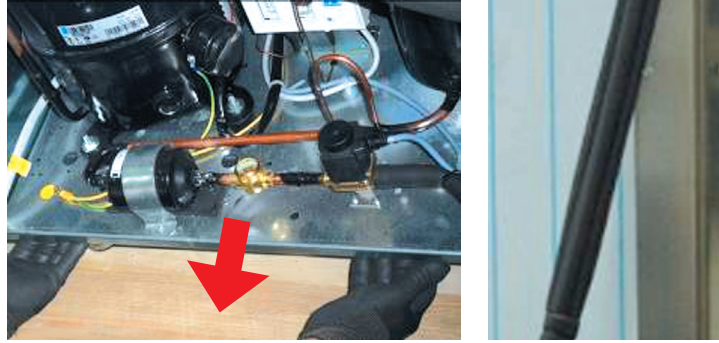

15. Flexible tubing lines allow movement.



Models from GBC30SG to GBF44-26SP

These models do not come equipped with a sliding base plate for the condensing unit. All the components are mounted directly to a base plate which is part of the unit's structure. The procedure for accessing these components is different from that for the model previously described.

However, the first eight steps are the same.

1. Remove the front panel.



Accessing the Condensing Unit (Self-Contained Models)

2. Unscrew the left and right side bolts from the compressor base plate at the sides of the condenser.

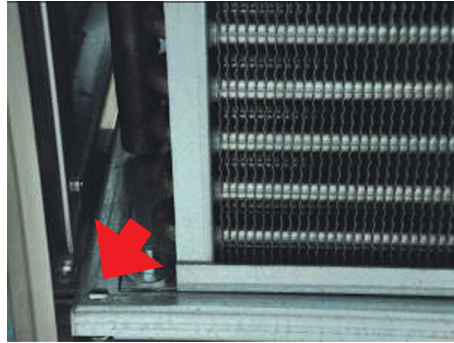

3. Disconnect the keypad wires.

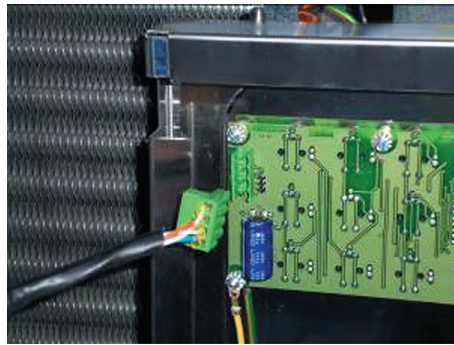

4. Loosen or cut the cable ties to extend the length to make clearance to slide out the compressor base.



Accessing the Condensing Unit (Self-Contained Models)

5. Cut the ties that fasten the drain duct.

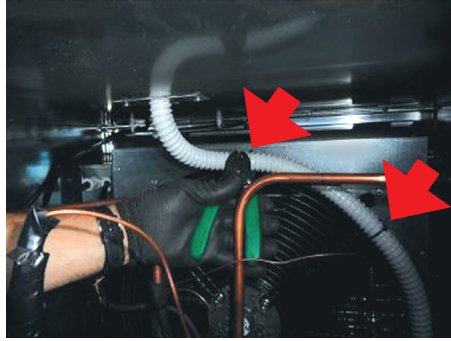

6. Move the drain duct so that it will not interfere with sliding out the compressor base plate.

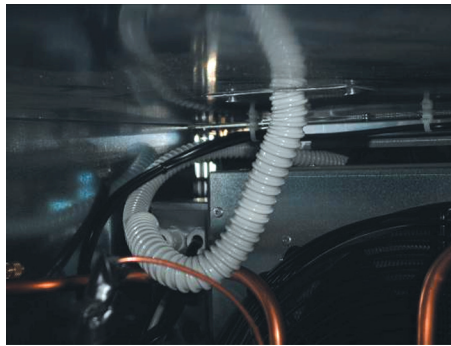

7. Remove the caps from the corner stainless steel angles.

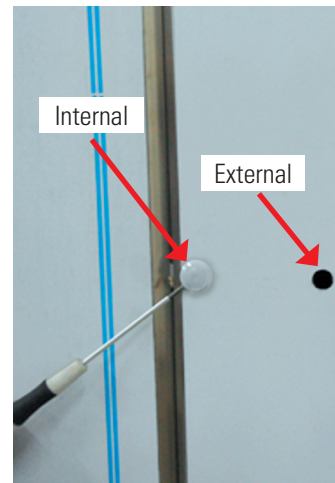

Accessing the Condensing Unit (Self-Contained Models)

8. With the caps removed, loosen the inner screws. Do not remove them. This is done at a 45° angle to the back panel.

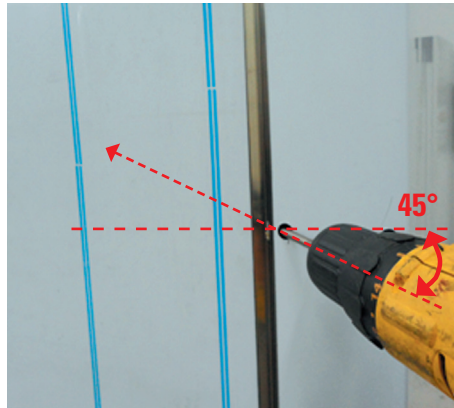

9. Unscrew the 8 bolts from the bottom of the cabinet (4 each side).



10. On the front side, lift the cabinet up enough so the drain duct will clear the condenser coil.

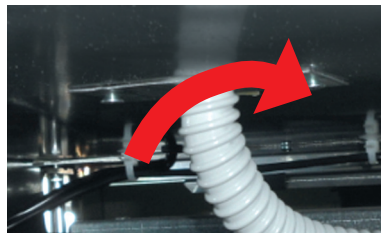
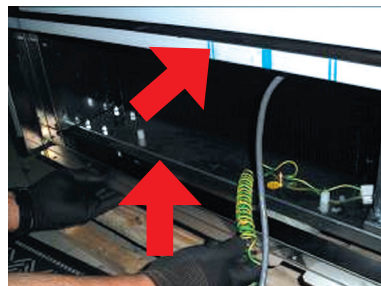

Accessing the Condensing Unit (Self-Contained Models)

11. Keep the cabinet base in place and push the cabinet body from back to front enough to access the components.

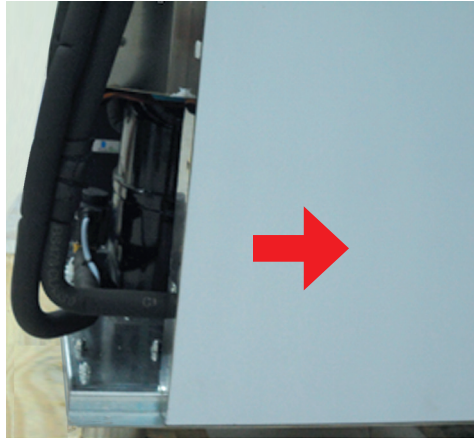

Model GBF15-11S

1. Unscrew the right side panel (3 screws).

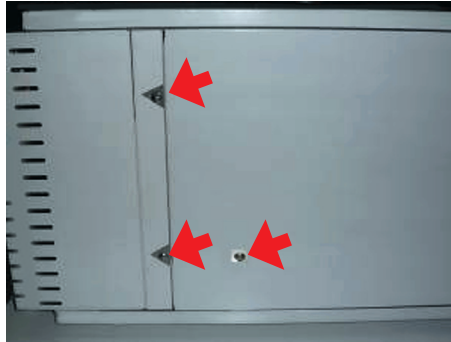

2. Unscrew the back right side panel (3 screws).

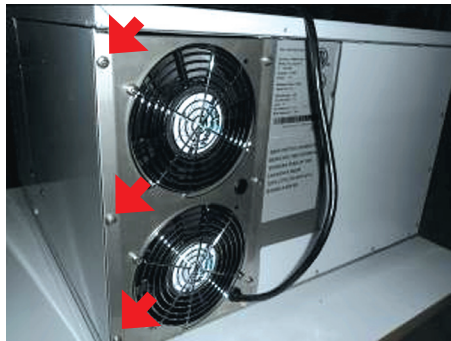

Accessing the Condensing Unit (Self-Contained Models)

- Remove the right side panel to access the condensing unit.

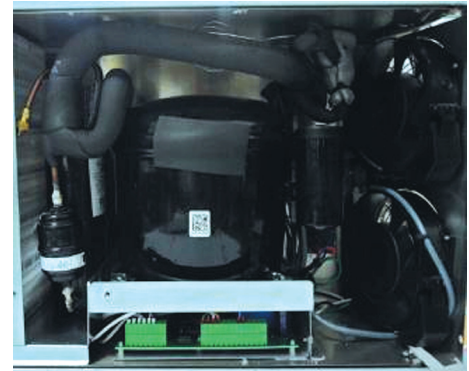

Remote Units – Models GBF440-38R and GBF837-727R

Remote units have the condensing unit in a separate box. To access the condensing unit, unscrew the metal top cover.

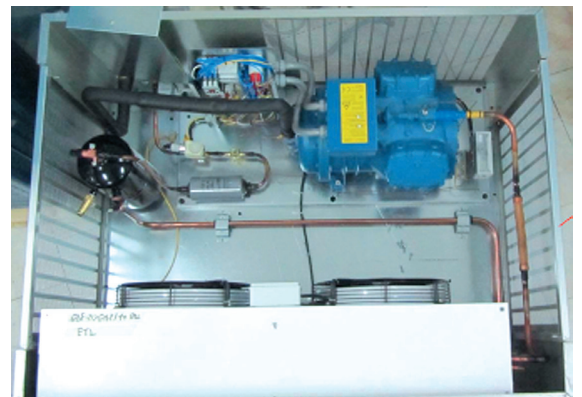
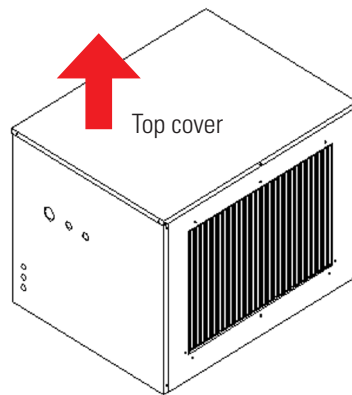

Accessing the Evaporator Assembly

All units, including remote and self-contained models, are equipped with one evaporator assembly, consisting of:

- An evaporator coil
- One or more evaporator fans (depending on the model)
- A thermal expansion valve (in some cases a MOP valve)
- A temperature sensor located on the evaporator output (defrost probe)
- A hinged cover panel holding the fans and guards
- A temperature sensor mounted to the panel (cabinet probe)

Evaporator Assembly Description

Evaporator Assembly – Small Units



Evaporator Assembly – Large Units

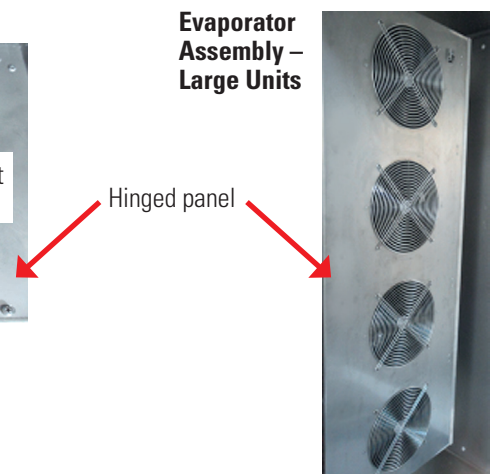

Evaporator Assembly – Components

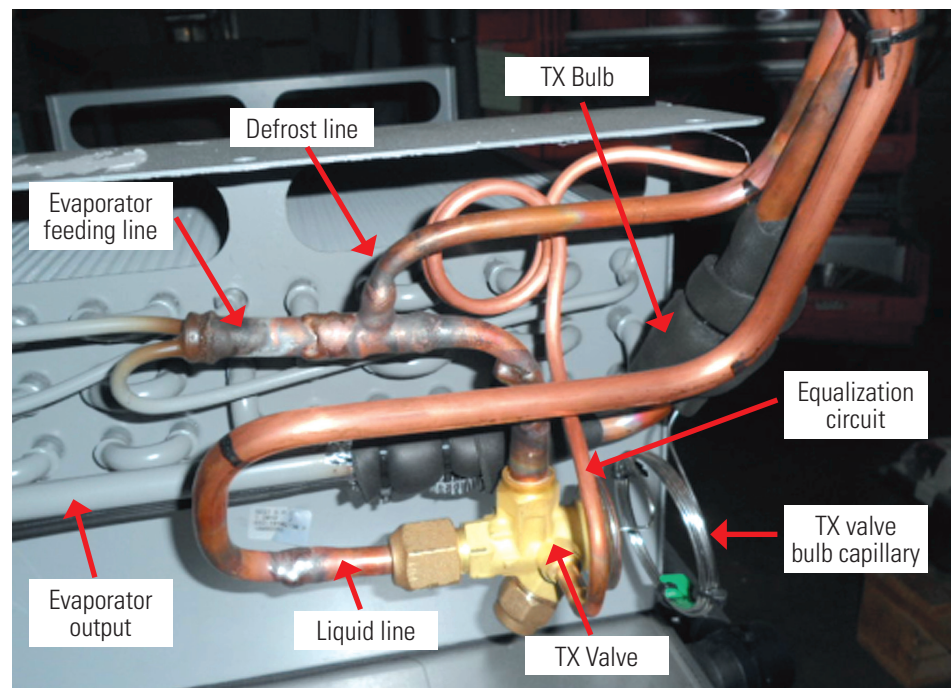

Accessing the Evaporator Assembly (continued)

Evaporator Assembly – Defrost Probe

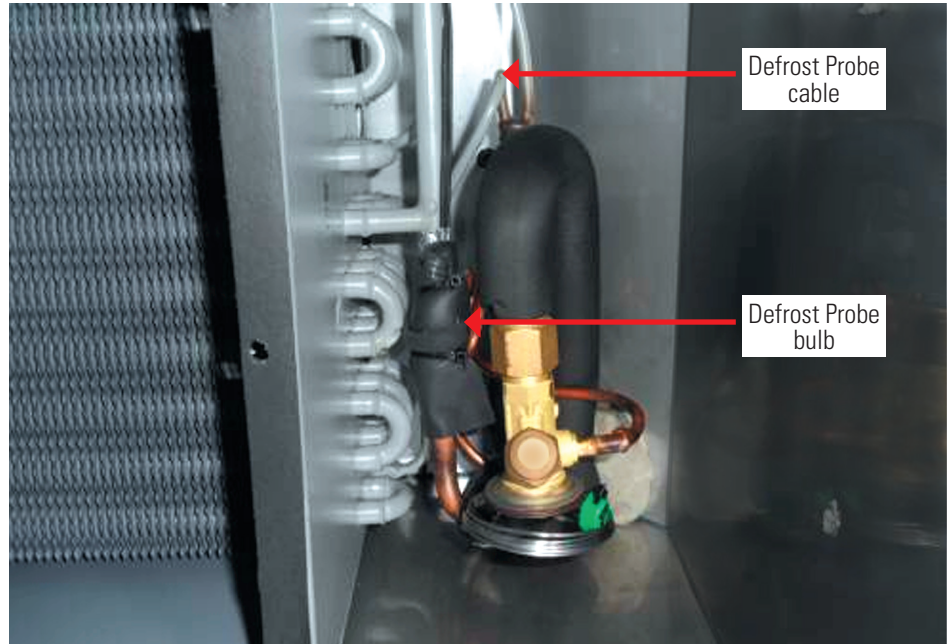

Accessing the Evaporator

1. Remove the screws that attach the hinged panel.



2. Lift the panel up and remove it.



Replacing the Temperature Sensing Probes

Cabinet Probe

1. Remove the metal guard.

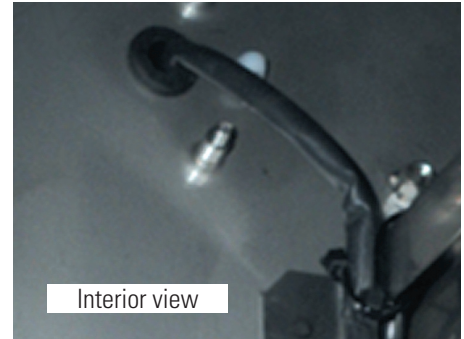

2. Cut and remove the plastic mounting tie.
3. Remove the probe wires from the main control terminals.
4. Cut off the probe bulb and all wire ties.
5. Attach the wires from the replacement probe wires to the wires of the existing probe.
6. From the controller side, pull the wire of the existing probe to route the new probe wires correctly.
7. Attach the wires to the Main Board.
8. Mount the probe into position.
9. Replace any wire ties.
10. Reinstall the guard.

Replacing the Temperature Sensing Probes (continued)

Evaporator (Defrost) Probe

Defrost Probe Bulb

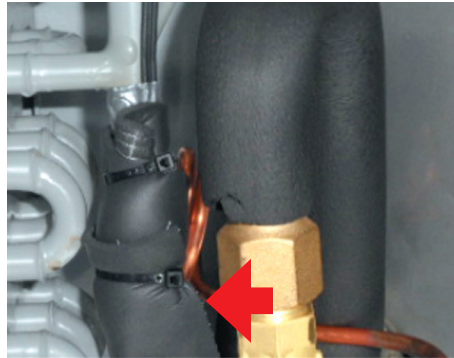

Defrost Probe Cable

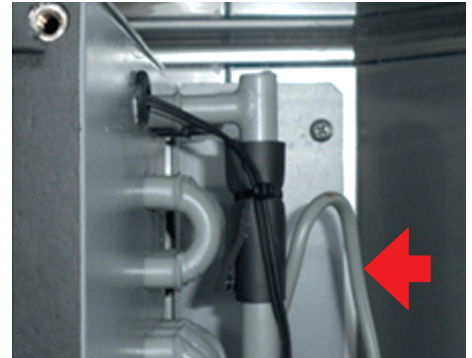

1. Remove the insulation.
2. Remove the aluminum tape.
3. Cut and remove the plastic mounting tie.
4. Cut off the probe bulb and all wire ties.
5. Attach the wires from the replacement probe wires to the wires of the existing probe.
6. From the controller side, pull the wire of the existing probe to route the new probe wires correctly.
7. Attach the wires to the Main Board.
8. Mount the probe into position.
9. Replace any wire ties.
10. Replace the aluminum tape.
11. Reinstall the insulation.

Replacing the Temperature Sensing Probes (continued)

Needle Probe

Needle Probe Element

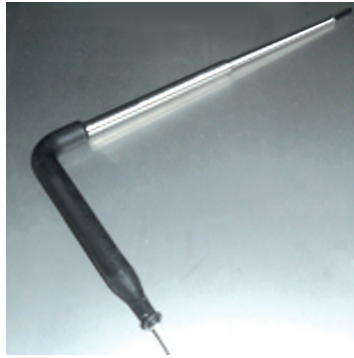

Needle Probe Cable Port

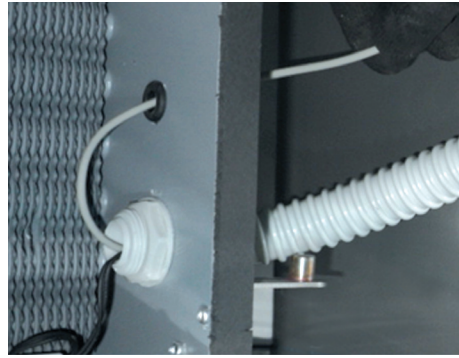

1. Cut off the probe's bulb.
2. Remove the probe wires from the main control terminals.
3. Attach the wires from the replacement probe wires to the wires of the existing probe.
4. From the controller side, pull the wire of the existing probe to route the new probe wires correctly.
5. Attach the wires to the Main Board.

Replacing the Evaporator Fan

1. Remove the screws that mount the fan guard.

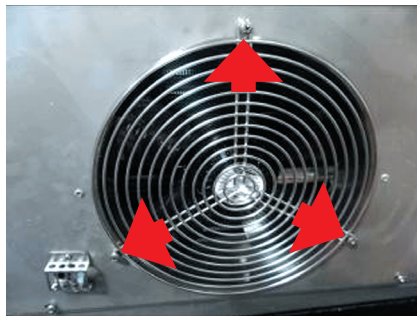

2. Open the panel and remove the fan mounting screws.

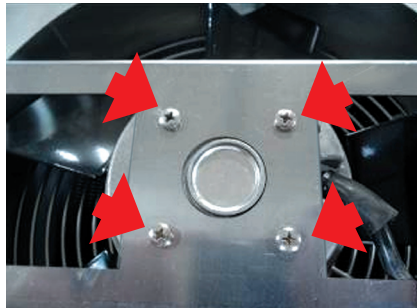

Replacing the Temperature Sensing Probes (continued)

3. Remove the fan/motor assembly.
4. Remove the fan wires from the terminal block.
5. Cut the wires close to the motor.
6. Mount the fan to the brace with four screws.
7. Attach the end of the wires of the fan to the old wires and pull the wires from the control compartment to route them correctly.
8. Remove the old wires.
9. Connect the wires to the terminal block.
10. Close the panel.
11. Reinstall the fan guard.

Replacing the Door Switch

Model GBF15-11S

1. Remove the front panel (see page 29).
2. Remove door switch mounting screws.



3. Disconnect the switch wires from terminals 48 & 49 on the main control.

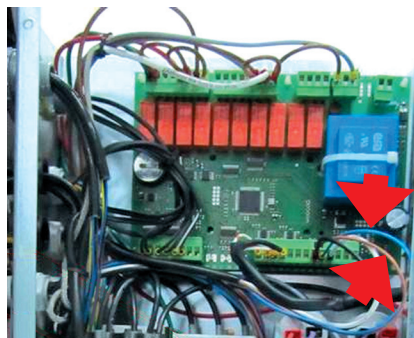

4. Remove the switch.
5. Install new switch by reversing the above steps

Replacing the Door Switch (continued)

Models GBC30SG to GBF171-132S

1. Remove the front panel (see page 29).
2. Unscrew the switch mounting bolt/nut.



3. Disconnect the switch wires from terminals 48 & 49 on the main control.

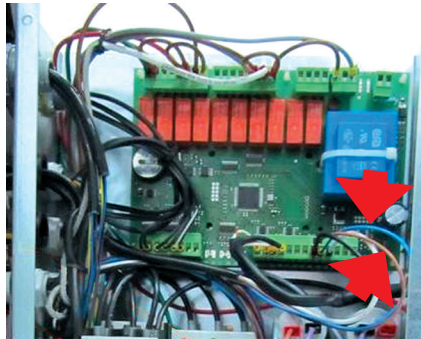

4. Remove the switch.
5. Install new switch by reversing the above steps.

Replacing the Pressure Switch

Occasionally the pressure switch can fail or become blocked and an "hP" alarm will be displayed even though the pressures are good.

- To replace the pressure switch, the capillary tubes must be disconnected.
- The high pressure capillary tube is connected to the liquid receiver upper tap.

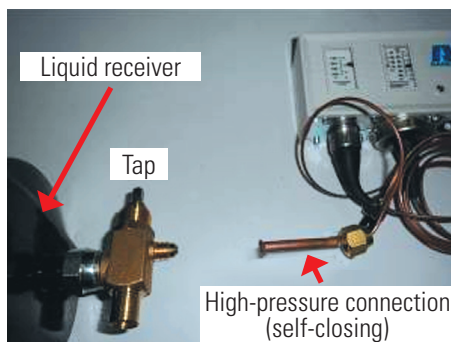

Replacing the Pressure Switch (continued)

- Before removing the capillary tube connections, the tap must be closed to prevent refrigerant loss.
- On the low pressure side, there is a self-closing ¼" SAE Schroeder connector.

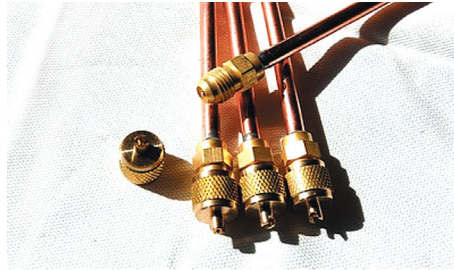

Replacing the Door Frame Heater

When a Door Frame Heater stops working, it could be a problem with the heater, such as an open element or a short. The problem could also be an interrupted power supply. Test the power supply before replacing the heater. Test the heater using the following specifications:

	115V	220V
Length	7.8 Ft.	(Heated) 6.5 ft.
Resistance	1.4 kΩ	2.4 kΩ
Current	80 mA	90 mA

To replace the heater:

1. Insert a thin knife blade between the edge of the plastic cover strip and the frame. You may need to tap lightly on the knife to insert it.



2. Pry the strip up and out. Do this for all the strips.
3. Disconnect the wire leads and remove the defective heater.

Replacing the Door Frame Heater (continued)

4. Insert the replacement heater in the channel and connect the wire leads.

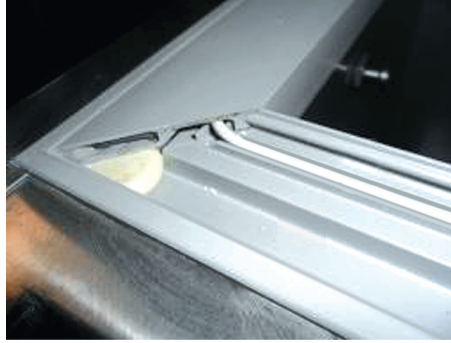

5. Replace the plastic cover strips and snap them in place by hand.

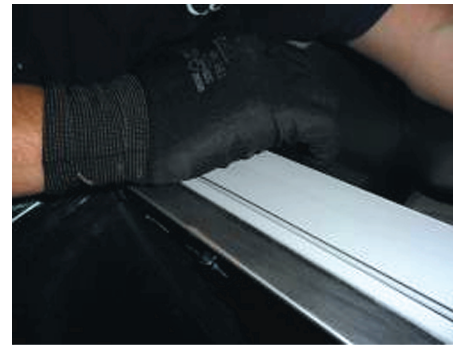

Replacing the Relay Board

1. Disconnect the power supply.
2. Mark and remove all wires.
3. The board is mounted with 6 plastic clips. Squeeze the tabs of each clip and remove the board.

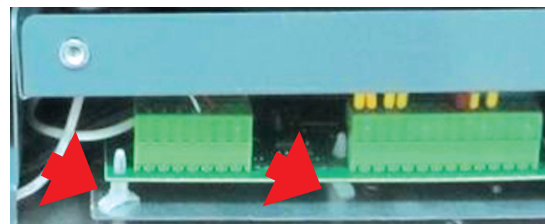

Replacing the Relay Board (continued)

4. Insert replacement board on clips, press down to snap in place.
5. Rewire according to the wiring marking and wiring diagram.
6. Ensure all parameters are set correctly (see Parameter List, page XX).

Replacing the Keypad

1. Remove the front panel (see page 29).
2. Disconnect the wiring harness.

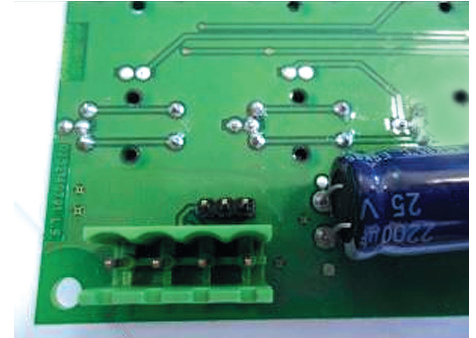
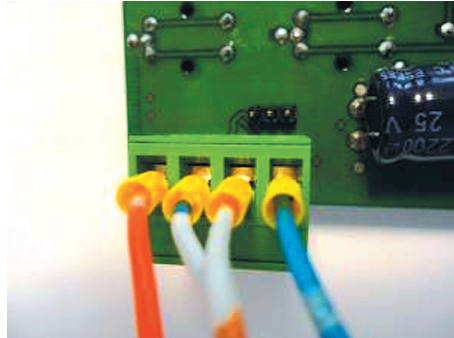

3. Remove the mounting nuts, lock washers and flat washers.

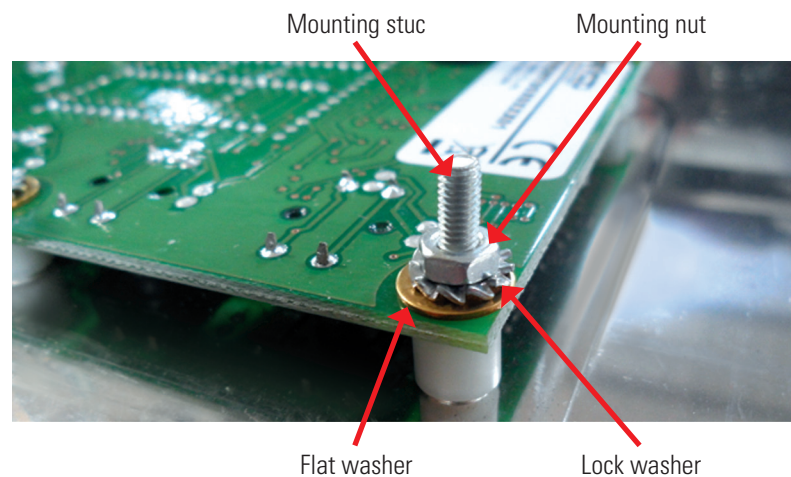

4. Remove the board from the mounting studs.
5. Install replacement board by reversing the above procedure.

Vacuum and Charging Procedure

WARNING: Before performing any service that involves electrical connection or disconnection and/or exposure to electrical components, always follow the Electrical LOCKOUT/TAGOUT Procedure. Disconnect all circuits. Failure to comply can cause property damage, injury or death.

Always perform a vacuum and charging procedure when any of the following actions have been done:

- Replacement of compressor
- Replacement of solenoid valve body
- Replacement of condenser
- Replacement of evaporator
- Replacement of thermal expansion valve
- Replacement of liquid receiver or oil separator
- Replacement of a filter
- Leak repair
- Replacement of tubing
- Any action that involves opening the refrigeration system

NOTE: Always replace the filter/drier before beginning a vacuum and charging procedure.

NOTE: Refer to Data Chart for correct amount of refrigerant for each model.

NOTE: Ensure all refrigerant is recovered before pulling a vacuum on the system. For the best results, pull the vacuum from more than one point in the system.

Vacuum and Charging Procedure (continued)

Vacuum and Charging Instructions

Self-Contained Models

Attach vacuum pump to the compressor check pressure valve and liquid receiver valve (shown).

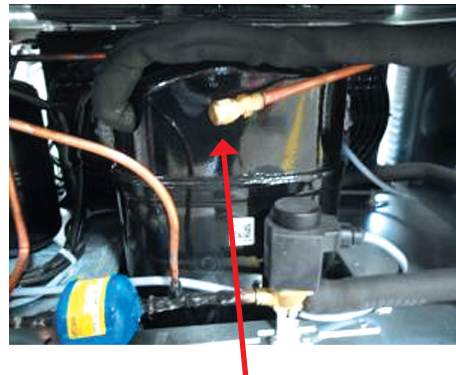

Compressor check pressure valve



Liquid receiver valve

Remote Models

Attach vacuum pump to the compressor check pressure valve and liquid receiver valve (shown above).

A split evaporator unit is also equipped with one or more additional valves that can be used to pull a vacuum and charge the system. This valve can be used to pull a vacuum in the evaporator unit in two ways:

Pull a vacuum in the entire system with the condensing and evaporating units connected and recharge the entire system.

Because these units are equipped with self-closing quick-connections, the condensing section can be separated. A vacuum can be pulled and refrigerant can be charged in this section. A vacuum can then be pulled on the evaporator section. Connect both suction and liquid lines to the evaporator to pull a vacuum into them as well. Once the system has been pumped down, simply connect the lines to the condensing unit that has already been charged.

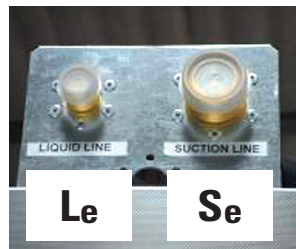

Quick connections – evaporator side (Top of cabinet)

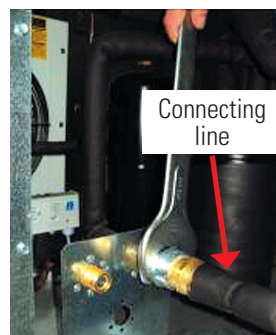

Unscrewing quick connections

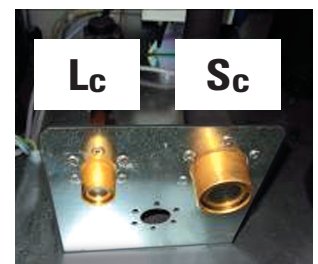

Quick connections – condenser side (Condensor box)

Vacuum and Charging Procedure (continued)

This last option is very helpful if only one side of the system is to be opened for repair. For example: if a compressor needs to be replaced, it's not necessary to open the entire system. Simply disconnect the lines at "Lc" & "Sc" to remove the compressor.

Vacuum and Charging Recommendations

- Use a vacuum pump rated at 50gpm minimum.
- Pull the vacuum for 1½ hours minimum
- Replace the filter/drier whenever the system has been opened.

Section 5 Schematics & Wiring Diagrams

- Component Schematic
- Wiring Diagram Single-Phase (self-contained)
- Wiring Diagram 3-phase Hot Gas Defrost (self-contained)
- Wiring Diagram 3-phase No Active Defrost (remote)

Appendices

I. Model Numbers

MODEL NUMBER	CHILLING OUTPUT *	FREEZING OUTPUT **	UNIT TYPE ***
GBF15-11S	15	11	S
GBC30SG	30	NO FREEZING	SG
GBF30-17SG	30	17	SG
GBF44-26SG	44	26	SG
GBF30-17SP	30	17	SP
GBF44-26SP	44	26	SP
GBC39S	39	NO FREEZING	S
GBF39-24S	39	24	S
GBF52-37S	52	37	S
GBF61-44S	61	44	S
GBF77-55S	77	55	S
GBF176-143S	176	143	S
GBF242-209S	242	209	S
GBC88S	88	NO FREEZING	S
GBF88-66S	88	66	S
GBF143-110S	143	110	S
GBC112S	112	NO FREEZING	S
GBF112-77S	112	77	S
GBF171-132S	171	132	S
GBF440-385R	440	385	R
GBF837-727R	837	727	R

* Maximum amount of food (pounds) that can be chilled in 90 minutes

** Maximum amount of food (pounds) that can be frozen in 270 minutes

*** S = Self-Contained; G= Gastronorm; P= Pastry; R = Remote

II. Data Chart

	COMPRESSOR RLA	COMPRESSOR LRA	MCA	MOP	CONDENSER FAN A	EVAPORATOR FAN A	VOLT/FREQUENCY	TOTAL A	REFRIGERANT TYPE	AMOUNT (Oz)	HIGH SIDE (Psig)	LOW SIDE (Psig)
GBF15-11S							100-115V/60 Hz/1Ph*	5.0	R404A	18	331	174
GBC30SG							100-115V/60 Hz/1Ph*	12.0		30		
GBF30-17SG							100-115V/60 Hz/1Ph*	12.0		30		
GBF44-26SG							100-115V/60 Hz/1Ph*	15.5		30		
GBF30-17SP							100-115V/60 Hz/1Ph*	12.0		30		
GBF44-26SP							100-115V/60 Hz/1Ph*	15.5		30		
GBC39S							100-115V/60 Hz/1Ph*	15.5		31		
GBF39-24S							100-115V/60 Hz/1Ph*	15.5		31		
GBF52-37S							208-220V/ 60 Hz/1Ph	10.5		31		
GBF61-44S							208-220V/ 60 Hz/1Ph	11.0		35		
GBF77-55S	7.1	49.0	10.5	17.6	1.2	0.4	220V60 Hz/3Ph	8.7		31		
GBF176-143S	7.1	49.0	10.8	17.9	1.2	0.8	220V60 Hz/3Ph	9.1		35		
GBF242-209S	17.3	56.0	23.6	40.9	1.2	0.8	220V60 Hz/3Ph	19.3		71		
GBC88S	7.1	49.0	10.8	17.9	1.2	0.8	220V60 Hz/3Ph	9.1		71		
GBF88-66S	7.1	49.0	10.8	17.9	1.2	0.8	220V60 Hz/3Ph	9.1		71		
GBF143-110S	17.3	56.0	23.6	40.9	1.2	0.8	220V60 Hz/3Ph	19.3		71		
GBC112S	7.1	49.0	10.8	17.9	1.2	0.8	220V60 Hz/3Ph	9.1		71		
GBF112-77S	7.1	49.0	10.8	17.9	1.2	0.8	220V60 Hz/3Ph	9.1		71		
GBF171-132S	17.3	56.0	23.6	40.9	1.2	0.8	220V60 Hz/3Ph	19.3		71		
GBF440-385R	39.7	148.0	54.8	94.5	1.9	3.3	208-220V/ 60 Hz/3Ph	19.3	206			
GBF837-727R	39.7	148.0	54.8	94.5	1.9	3.3	208-220V/ 60 Hz/3Ph	44.8	282			

* 208/240V/1Ph/60Hz also available

Component Schematic

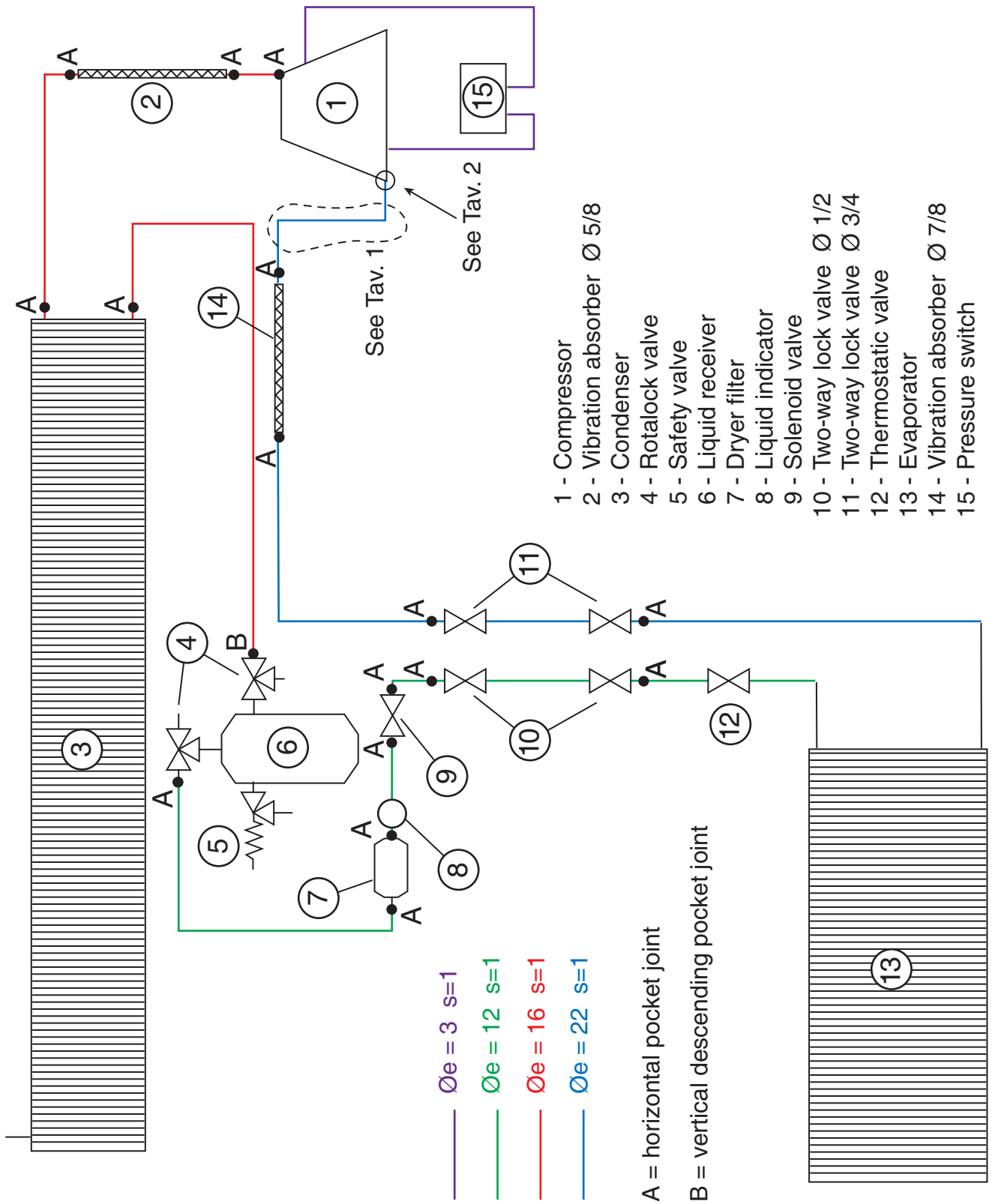

Wiring – Single-phase Units (Self-contained)

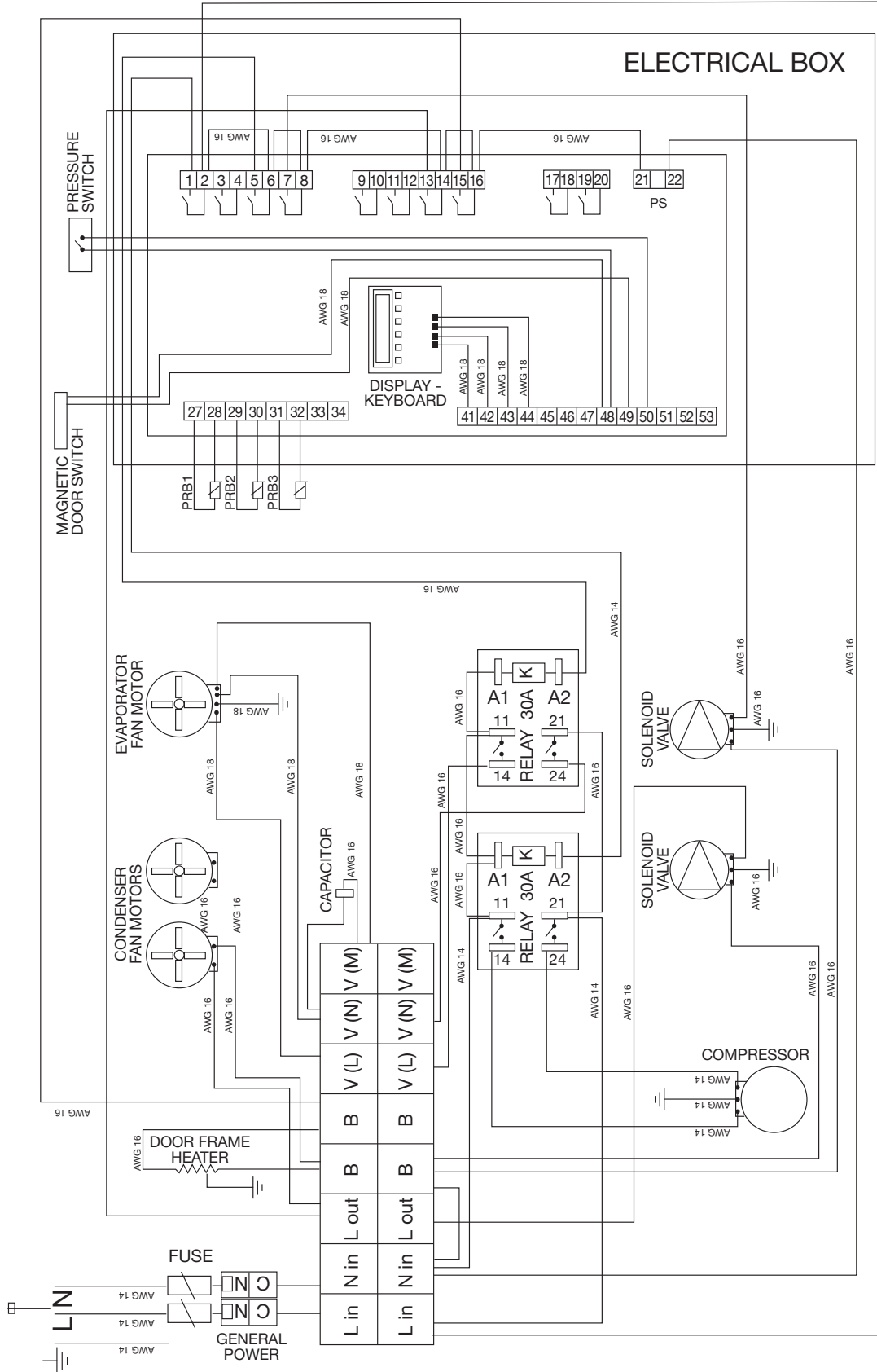

Wiring – 3-phase Units (Self-contained)

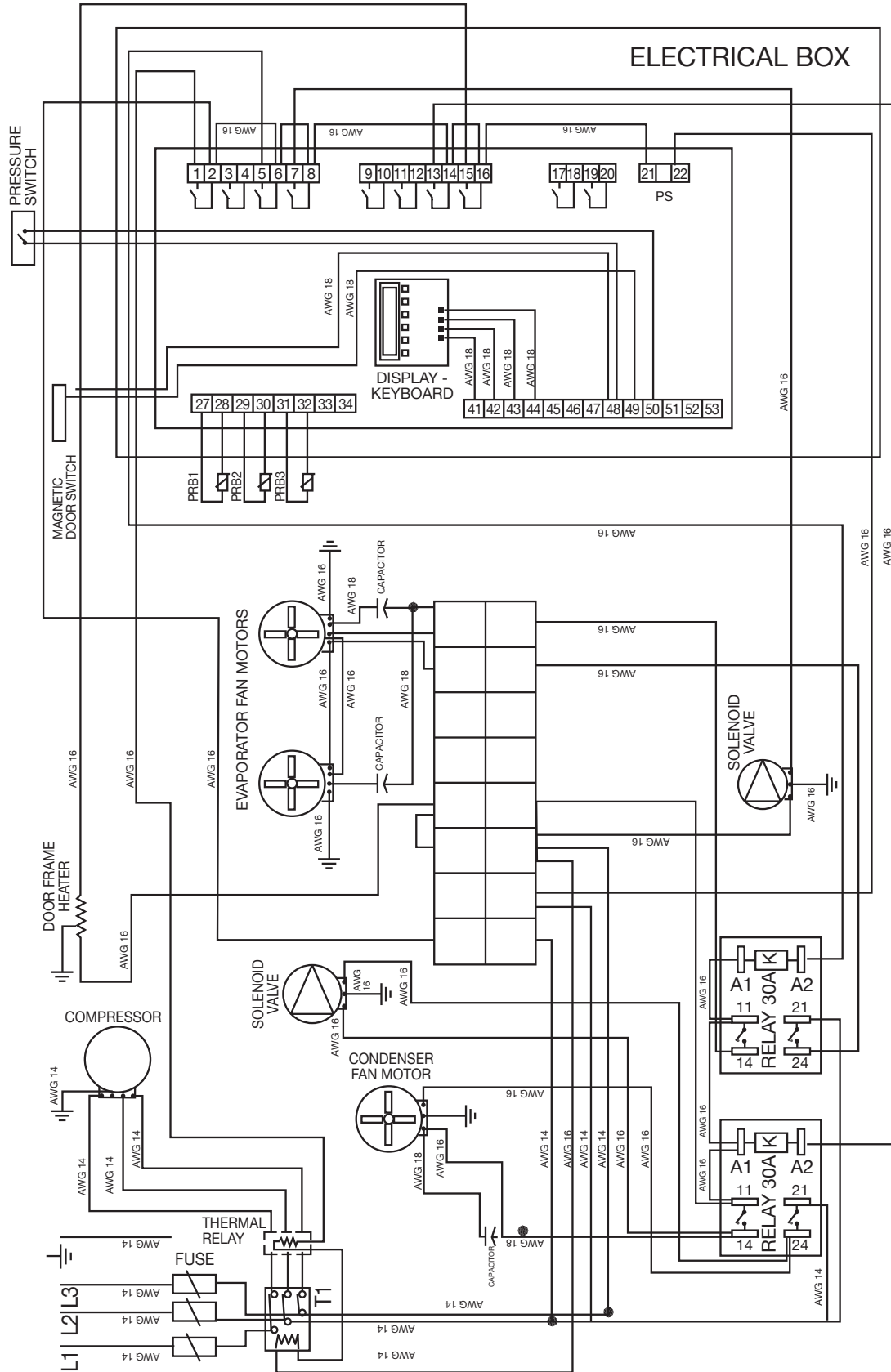

Wiring – 3-phase Units (with Remote Condensor)

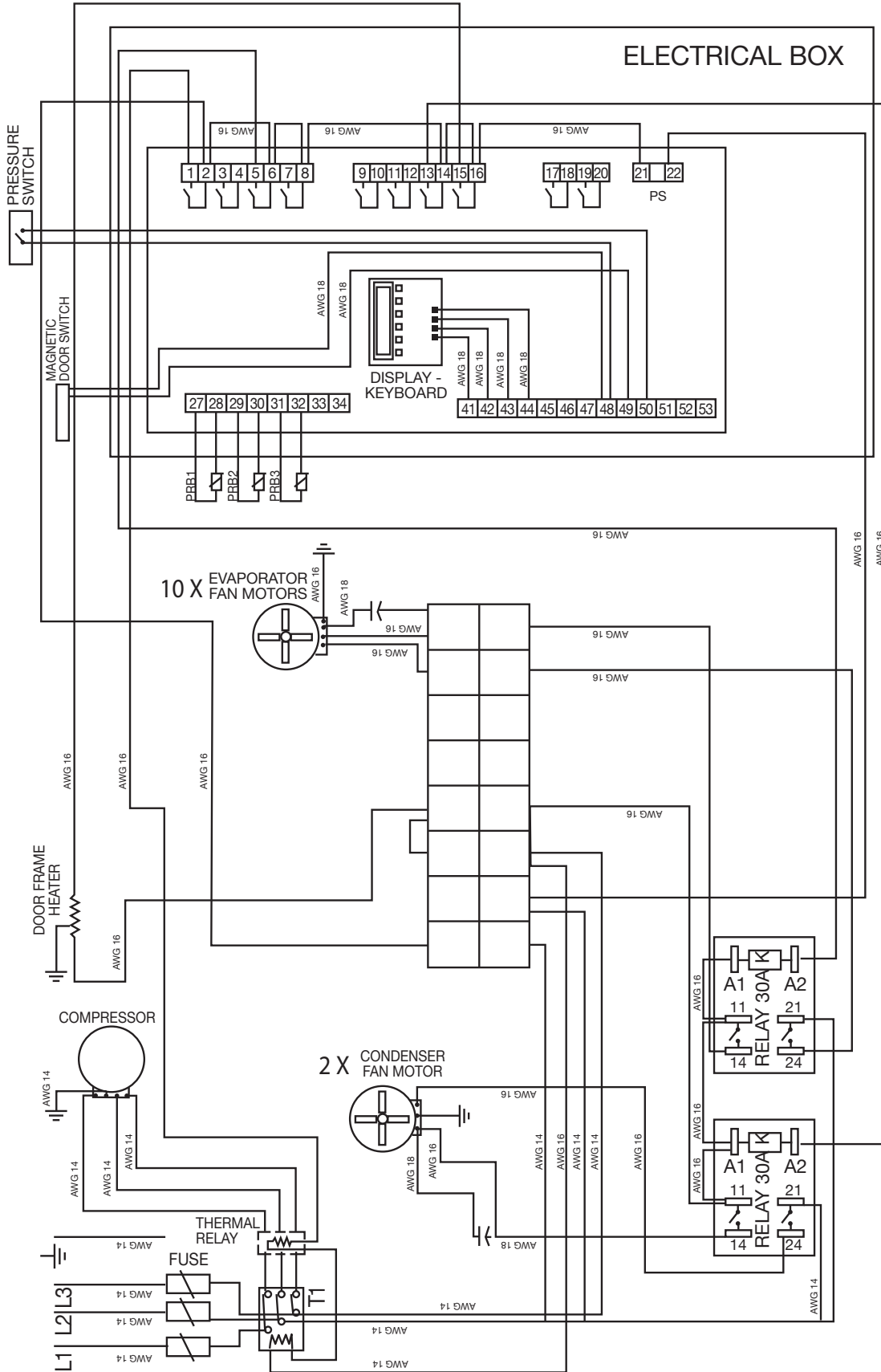

NOTES



