

OPERATOR'S MANUAL



Model R160 Frozen Food Dispenser

Original Operating Instructions

089364-M

April 2020 (Original Publication)
(Updated 4/22/2021)

Complete this page for quick reference when service is required:

Taylor distributor: _____

Address: _____

Phone: _____

Service: _____

Parts: _____

Date of installation: _____

Information found on the data label:

Model Number: _____

Serial Number: _____

Electrical Specs: Voltage _____ Cycle _____

 Phase _____

Maximum Fuse Size: _____ A

Minimum Wire Ampacity: _____ A

Note: Continuing research results in steady improvements; therefore, information in this manual is subject to change without notice.

Note: Only instructions originating from the factory or its authorized translation representative(s) are considered to be the original set of instructions.

© 2020 Taylor Company.
089364-M

Any unauthorized reproduction, disclosure, or distribution of copies by any person of any portion of this work may be a violation of copyright law of the United States of America and other countries, could result in the awarding of statutory damages of up to \$250,000 (17 USC 504) for infringement, and may result in further civil and criminal penalties. All rights reserved.



Taylor Company
750 N. Blackhawk Blvd.
Rockton, IL 61072

Table of Contents

Introduction	1
Unpacking and Installation.....	1
Intended Use.....	1
Specifications.....	1
Safety.....	2
Equipment Safety.....	4
Dispenser Assembly	6
Operator Panel and Controls	8
Startup and Operation.....	9
Loading the Hopper	9
Operation.....	9
Daily Closing: Disassembly, Defrost, and Cleaning	10
Defrost.....	10
Temperature Controller Operation and Menu Structure	11
Displaying and Changing Set Point Temperature	11
Locking the Controller.....	11
Error Detection.....	12
Troubleshooting	13
Part Identification	14
Dispenser Cabinet Assembly	14
Outlet Assembly	16
Interior Parts—Front View	17
Dispenser Cabinet Interior—Rear View.....	18
Operator Panel Components.....	20
Outlet Door Assembly.....	20
Drum Motor Assembly.....	21
Refrigeration System	22
General Operation.....	22
Defrost.....	22
Required Maintenance	22
Cleaning the Condenser Filter and Coil.....	23
Refrigeration System Components.....	24
Refrigeration Circuit (404A Refrigerant).....	26
Refrigeration Circuit (R290 Refrigerant)	27
Electrical Diagram.....	28
Electrical Diagram (with Replacement Controller)	29
Limited Warranty on Equipment.....	30
Limited Warranty on Parts	32
Ordering/Service Information	35
Data Label	35
Parts Warranty.....	35
Compressor Warranty Disclaimer.....	35
Service Information	36

Introduction

This Model R160 Frozen Food Dispenser is a refrigerated unit that dispenses frozen fries.

It is recommended that these operating procedures be followed closely to ensure correct assembly and disassembly of the Dispenser.

Unpacking and Installation

Remove all packing material from Dispenser. Open cabinet door. Disassemble, clean, sanitize, and dry the hopper and dispensing components. Clean, sanitize, and dry fry baskets. (See page 10 for disassembly and cleaning.) Re-assemble all components (see page 7 for startup and operation).

Intended Use

The Frozen Food Dispenser must only be used for the temporary frozen storage and dispensing of non-meat based food products at commercial restaurants and similar locations. Any other use would be deemed inappropriate. The Dispenser is designed for installation and use indoors, in a restaurant environment protected from weather, excessive heat, excessive humidity, and salt air.

HAZARD COMMUNICATION STANDARD

Hazard Communication Standard (HCS) procedures in this manual may include the use of chemical products. These chemical products will be highlighted with boldface letters followed by the abbreviation (HCS) in the text of the procedure. See the HCS Manual for the appropriate Material Safety Data Sheets (MSDS).

Specifications

Electrical Requirements

Domestic:

- 120V, 60 Hz, 8A, 1 Phase

International:

- 220–240V, 50 Hz, 4.6A, 1 Phase
- 220–240V, 60 Hz, 4.6A, 1 Phase

Internal Circuit Breaker:

- 15A

Dimensions

- Width 16.5 in. (419 mm)
- Depth 28 in. (711 mm)
- Height 67.75 in. (1,720 mm)

Minimum Operating Clearance

- 1 in. (2.6 cm) clearance on each side
- 2 in. (5 cm) clearance at the back
- Open to ceiling, minimum 24 in. (61 cm)

Weight

- Net: 257 lb. (117 kg)
- Crated: 289 lb. (131 kg)

Note: For Reference Only

Hopper Capacity

- 36 lb. (16.3 kg), weight may vary with product

Note: Weight may vary with product.

Operating Temperature

- -4°F to 0°F (-20°C to -18°C)

Note: (Recommended ambient operating temperature of 75°F [24°C])

- Climate Class = N

Refrigeration Specifications

- Refrigerant Type:
 - R290, 5.15 oz. (146 g)
 - Legacy units may use R404A, 13 oz. (368 g)
- Suction Pressure: 3 psi to 7 psi at -3°F to 3°F (21 kPa to 48 kPa at -19°C to -16°C)
- Operating Temperature: 4°F to 0°F (-15°C to -18°C)
- Factory Temperature Set Point: 0°F (-18°C)
- Factory Differential Set Point: 4°F (3°C)
- High Pressure Switch: opens at 425 psi (2890 kPa), resets at 325 psi (2210 kPa)

Insulation Blowing Gas

- HFO-1233ZD and HFO-1234ZE

Maximum Operating Altitude and Safe Tilt

- Maximum Altitude: 6,561 ft. (2,000 m)
- Maximum Tilt = 10 degrees

Noise Emissions

- < 70 dB (A)

FCC STATEMENT



CAUTION! This machine generates, uses, and can radiate radio frequency energy and, if not installed and used in accordance with the instruction manual, may cause interference to radio communications.

EMC STATEMENT

This equipment meets EMC directives:

- EN 55014-1:2006 + A1:2009
- EN55014-2:1997 + A1:2001 + A2:2008-Category II

Safety

Always follow these safety precautions when operating the Dispenser:



NOTICE! DO NOT operate this machine without reading this entire manual first. Failure to follow all of these operating instructions may result in damage to the machine, poor performance, health hazards, or personal injury.



IMPORTANT! *This machine is to be used only by trained personnel. It is not intended for use by children or people with reduced physical, sensory, or mental capabilities or lack of experience and knowledge. Where limited machine operation is allowed for public use, such as a self-serve application, supervision or instruction concerning the use of the machine by a person responsible for their safety is required. Children should be supervised to ensure that they do not play with the appliance.*



IMPORTANT! *Access to the service area of the machine must be restricted to persons having knowledge and practical experience with the machine, in particular as far as safety and hygiene are concerned.*



WARNING! DO NOT use a water jet to clean or rinse the machine. Failure to follow these instructions may result in serious electrical shock.



WARNING! Avoid injury.

- **DO NOT** operate the machine unless it is properly grounded.
- **DO NOT** operate the machine with larger fuses than specified on the machine's data label.
- All repairs should be performed by a Taylor service technician.
- The main power supplies to the machine must be disconnected prior to performing installation, repairs, or maintenance.

- Machines that are permanently connected to fixed wiring and for which leakage currents may exceed 10 mA, particularly when disconnected or not used for long periods, or during initial installation, shall have protective devices to protect against the leakage of current, such as a GFI, installed by the authorized personnel to the local codes.
- Stationary machines which are not equipped with a power cord and a plug or another device to disconnect the appliance from the power source must have an all-pole disconnecting device with a contact gap of at least 0.125 in. (3 mm) installed in the external installation.
- Supply cords used with this machine shall be oil-resistant, sheathed flexible cable not lighter than ordinary polychloroprene or other equivalent synthetic elastomer-sheathed cord (code designation 60245 IEC 57) installed with the proper cord anchorage to relieve conductors from strain, including twisting, at the terminals and protect the insulation of the conductors from abrasion.
- If the supply cord is damaged, it must be replaced by a Taylor service technician in order to avoid a hazard.

Failure to follow these instructions may result in electrocution. Contact your local authorized Taylor distributor for service.



CAUTION! This machine must be placed on a level surface. Use caution when moving the machine. Failure to comply may cause the machine to tip over and result in personal injury.



NOTICE! Cleaning and sanitizing schedules are governed by your federal, state, or local regulatory agencies and must be followed accordingly. Please see the cleaning section of this manual for the proper procedure to clean this machine.



IMPORTANT! If the crossed-out wheeled-bin symbol is affixed to this machine, it signifies that this machine is compliant with the EU Directives as well as other similar end-of-life legislation in effect after August 13, 2005. Therefore, it must be collected separately after its use is completed and cannot be disposed as unsorted municipal waste.

The user is responsible for delivering the machine to the appropriate collection facility, as specified by your local code.

For additional information regarding applicable local disposal laws, please contact the municipal waste facility and/or local authorized Taylor distributor.



WARNING! Only install this machine in a location where its use and maintenance is restricted to trained personnel. Failure to comply may result in personal injury.



CAUTION! Only trained and/or qualified personnel, licensed in refrigeration, should perform service to the refrigeration systems of this equipment. Failure to comply may result in personal injury from moving parts or damage to the machine.

Service functions described in this manual could cause irreversible damage to the machine and/or injury to personnel if performed improperly.

If the power cord is damaged, it must be replaced by the manufacturer, or its service agent, or a similarly qualified person in order to avoid a hazard.

Equipment Safety



Important:

- Turn the power switch off and disconnect the Dispenser power cord from the wall outlet before cleaning, moving, or servicing the Dispenser.
- Inspect the Dispenser on a regular basis to identify potential problems before they occur.
- Keep the Dispenser clean.
- Keep hands away from the outlet door and dispenser drum while the Dispenser is operating. Disconnect power before clearing a blocked outlet door or dispenser drum.
- Fry baskets may be hot. Pick them up by the handles only.
- **Do not** roll the Dispenser to the back sink for cleaning, this may cause unnecessary wear on the Dispenser.
- If the power cord is damaged it must be replaced by the manufacturer, or its service agent, or a similarly qualified person in order to avoid a hazard.
- Use only the power cord that came with the Dispenser. **Do not** use an extension cord.
- **Do not** modify the power cord.
- In a safety emergency, immediately disconnect the power cord from the wall outlet.
- **Do not** obstruct access to the wall outlet or place pressure on the power cord.
- **Do not SPRAY THE DISPENSER WITH LIQUID OR SOLVENTS.**
- It is not sealed against jetting fluids and contamination may get into sensitive components. Spraying the Dispenser may void the warranty.
- Use caution when handling heavy parts such as back and top panels.
- Always re-install service panels when maintenance is complete.
- **Do not** drill or otherwise puncture cabinet walls or top.
- Keep machine upright at all times.
- Keep ventilation openings in the machine enclosure clear of obstruction, particularly in the bottom back panel.
- **Do not** use mechanical devices or other means to accelerate the defrosting process other than those recommended by the manufacturer. **Do not** drill or puncture cabinet walls or top.
- **Do not** damage the refrigerant circuit.
- **Do not** use electrical appliances inside the food storage compartments of the machine, unless they are of the type recommended by the manufacturer.
- **Do not** store explosive substances such as aerosol cans with a flammable propellant in this machine.

Equipment Safety Cont.

Electric Shock

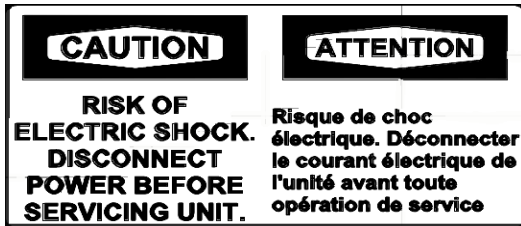

Figure-1: US and Canada

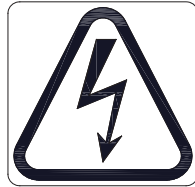

Figure-2: International

CAUTION!

Risk of electric shock. disconnect power before servicing unit.

Located near power cord inlet.

Moving Parts



Figure-3: US and Canada



Figure-4: international

CAUTION!

Disconnect power before servicing unit.

Located on the top and bottom rear access panels, side access panel top cover and near power cord inlet.

Pinch Point

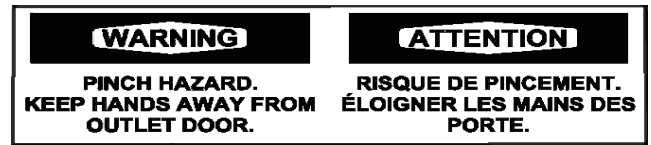

Figure-5: US and Canada



Figure-6: International

CAUTION!

Moving parts. hands should not be placed near or below the outlet door.

Located on the front and applies to the outlet door assembly.

Risk of Fire



Figure-7: Domestic/International

Located on the rear access panel and applies to the cabinet insulation and refrigeration system.

CAUTION!

Risk of fire. Keep open flame from exposed insulation when servicing refrigerant is flammable. (Model R160 only R290 refrigerant).

Warning: Keep ventilation openings in the machine enclosure clear of obstruction, particularly in the back-bottom panel.

Caution: The R160 utilizes R290 (propane) as a refrigerant. Release of refrigerant into the atmosphere is strictly prohibited.

Caution: Propane (R290) is highly flammable.

Dispenser Assembly

Note: Before assembling the Dispenser, it is recommended that all parts be cleaned, sanitized, dried, and handled in a sanitary manner. Refer to the Cleaning Procedures for more information.

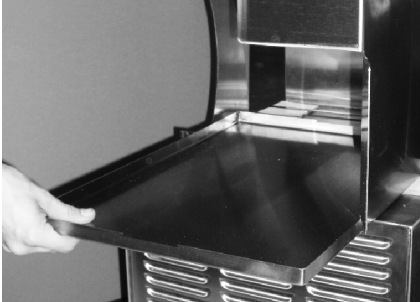

Figure-8: Drip Tray

1. Install the drip tray under the cabinet outlet, lifting it slightly over the cabinet supports.

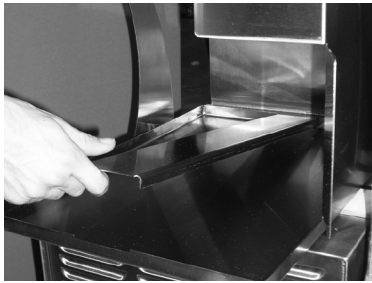

Figure-9: Drip Tray Spacer

2. Position the drip tray spacer on the drip tray in the mounting slots. Install the front edge of the divider first, and then set the back side of the divider into the slot at the back of the tray.



Figure-10: Door Alignment Arrow

3. With the Dispenser turned off, align the outlet door with the door alignment arrow and slide the outlet door over the shaft toward the back wall engaging the alignment arrow.



Figure-11: Outlet Door

4. With your hands removed, turn the Dispenser on. The outlet door will retract into the closed position.



Figure-12: Drum

5. Install the drum into the hopper, making sure the square opening in the drum is pointed toward the rear of the hopper.



Figure-13 Fry Diverter

6. Install the fry diverter into the hopper by sliding the fry diverter tabs into the slots on the inside hopper wall.



Figure-14: Hopper Assembly

7. Install the hopper assembly into the cabinet by sliding them onto the hopper supports.

Do not force the drum onto the shaft. Rotate the drum in the hopper until the square opening meshes with the drum motor shaft, then slide the hopper assembly backward until it drops into place.

Operator Panel and Controls

The operator panel consists of the On/Off switch, the temperature controller with display, and the Dispenser button.



Figure-15

On/Off Switch controls the main power that turns the Dispenser on and off. The switch illuminates when on.

Temperature Controller maintains the cabinet temperature and displays the current cabinet temperature. The Dispenser's controller can also detect an abnormal refrigeration condition. When an error condition is detected the display will show the error that has occurred.

Dispenser Button operates both the dispensing drum and outlet door. When the Dispenser button is pressed the outlet door moves to the dispensing (open) position and the drum begins to turn in the hopper. When the desired amount of frozen fries has dispensed into the basket, the Dispenser button is released, the dispenser drum stops rotating and the outlet door closes.

Startup and Operation

- When the Dispenser is in place, lock both front casters.
- Make sure the power switch on the left side of the operator panel is turned off.
- Assemble the Dispenser (see "Dispenser Assembly" on page-6).
- Plug the power cord into an approved outlet and turn the Dispenser on.

Note: Turn the Dispenser on a minimum of 90 minutes (depending on ambient temperature conditions) before loading frozen product into the Dispenser. When the temperature drops to 10°F (-12°C), load frozen product into the Dispenser and use the Dispenser.

Note: This machine is to be used only for dispensing frozen fries or other approved products. Any other use may cause injury to personnel or damage to the machine.

The Frozen Food Dispenser is intended to maintain and dispense frozen fries on demand eliminating the need for staging full baskets of fries. Dispensing and cooking fries direct from the freezer results in improved fry quality, consistency, and yield.

Important! Do not stage full baskets of fries on the side-mount basket rack, if equipped. The side-mount basket rack should be used for empty fry basket storage only.

Loading the Hopper

Note: To achieve optimum fry yield and the most consistent basket loads, it is important to use the following technique for loading frozen fries into the hopper.

For each bag or box of fries:

1. Remove the bag of fries from the case. Be careful not to crush the fries.
2. Open the top of the bag or box completely. (A partially open bag may retain fries.)
3. Hold the opened end of the bag closed with your hand and lay it in the hopper with the opening toward the side opposite of the diverter.
4. Release the opened end of the bag or box.

5. Empty the bag into the hopper by pulling it evenly toward the diverter. When adding multiple bags of fries, alternate the placement of the bag in the hopper opposite of the previous bag. The second bag of fries should be emptied into the hopper with the opening toward the diverter and pulling it evenly toward the hopper wall opposite the diverter.

Note: This crisscross loading method ensures an even distribution of fry lengths in the hopper and the baskets.

Note: The Dispenser hopper holds 36 lb. (16.3 kg). Hopper capacity may vary depending on the product.



WARNING! Pinch Hazard. DO NOT place hands or fingers near the drum inside the hoppers while this machine is in operation. Hands or fingers could be pinched between the drum and the hopper as the drum turns. Failure to comply may result in personal injury from moving parts or damage to the machine.

Note: Do not shake or drop fries from the bag or box into the hopper, this will result in unnecessary fry breakage.

Operation

1. Place a basket under the outlet door in the loading position.
2. Press and hold the Dispenser button until the desired amount of fries are dispensed into the basket.
3. Release the Dispense button.
4. Remove the basket.

Daily Closing: Disassembly, Defrost, and Cleaning

Important! These cleaning instructions are intended as a guide. Refer to your local, state, and federal regulations for any additional instructions and for cleaning frequency requirements.

Remove all baskets from the dispense area and basket rack. Open the cabinet door and remove the hopper assembly by lifting the front of the hopper up slightly and pulling forward on the hopper assembly.

Remove any unused product from the hopper by emptying the product into an approved storage container. Place the storage container immediately into a freezer to maintain frozen product.

Defrost

Because the Dispenser employs a cold wall design, it will be necessary to manually defrost the cabinet daily.

1. Press the On/Off switch to the Off position and unplug the power cord.
2. With the Dispenser off and the remaining product removed, move the outlet door into the open position.
3. Remove the outlet door from the mounting shaft.
4. Lift and remove the drip tray and drip tray spacer.
5. Open the cabinet door and allow 1 hour to defrost.



CAUTION! Never use a sharp object to remove frost buildup. Never drill or otherwise puncture cabinet walls or top. Failure to follow this instruction may result in damage to the Dispenser.

Take the removable components from the Dispenser to the washing area. Wash them with a hot solution of detergent and water. Rinse each component with clear water and sanitize (wash/rinse/sanitize) **(HCS)**. Allow components to air-dry.

Note: The removable components are **not** dishwasher safe.

Move the Dispenser away from the wall to clean behind and underneath it.

Do not roll the Dispenser to the back sink for cleaning. This will cause unnecessary wear on the Dispenser.

Once the cabinet is free of frost, wipe down the internal and external sides of the cabinet with a hot solution of detergent and water. Rinse with clear water and repeat the wipe down process with sanitizing solution **(HCS)** and allow to air-dry.



CAUTION! DO NOT spray the Dispenser with Liquid or Solvents. The Dispenser does not provide a water tight seal. Failure to follow this instruction may allow contaminants and moisture may get into sensitive components.

Dry all components and re-assemble the Dispenser (see "Dispenser Assembly" on page-6). Move the Dispenser back into place.

Important! The Dispenser must be accessible from all sides for routine cleaning and maintenance. A minimum of 1 in. (26 mm) clearance on both sides and 2 in. (50 mm) behind the Dispenser is recommended.

Temperature Controller Operation and Menu Structure

The Space Saver Frozen Food Dispenser uses an electronic temperature controller to operate the refrigeration system. It directly controls the compressor. The following sections will cover basic operation and programming of this controller.



Figure-16

Key and LED Descriptions	
SET key	Displays current set point, allows set point changes
Up key	Increases displayed value, browses up lists of parameters
Down key	Decreases displayed value, browses down lists of parameters
Compressor Enabled LED	On: Compressor enabled
	Flashing: Anti-short cycle delay enabled
Alarm LED	On: Alarm is occurring
Measurement Units	Displays the current measurement unit
Temperature Display	Displays the current temperature

Displaying and Changing Set Point

Temperature

The set point is the temperature at which the refrigeration system will turn off. The recommended set point is 0°F (-18°C). The set point can be viewed and adjusted with the SET key. Press and immediately release the SET key to view the current set point. To change the set point, press and hold the SET key for 4 seconds or until the display is flashing. The set point can be adjusted by using the Up and Down arrow keys. The new set point is stored by pressing the SET key again.

Locking the Controller

The controller keys may be locked by pressing both the Up and Down keys for 3 seconds. The display will flash PoF. The keys are now locked and cannot be used to change any parameter (the set point is still visible by pressing the SET key). To unlock the keys, once again press both the Up and Down arrow keys for 3 seconds. The display will show Pon and the keys will be unlocked.

Error Detection

Note: Errors relating to the refrigeration systems, while requiring corrective action, will not disable the fry dispensing portion of the machine.

The Temperature Controller is capable of detecting conditions that fall outside normal operation. In such cases, the controller will display an alarm message to warn the operator that corrective action should be taken. The alarm consists of a flashing message on the controller display. The flashing message will remain until the error is corrected. Some alarm conditions may be easily fixed, while others may require the attention of a qualified service technician. The chart below provides an explanation of each error message and what action may be needed to correct the problem.

Alarm Message	Cause	Corrective Action
P1 flashing	Thermostat probe failure	Power off, wait 1 minute, power on.
		Check probe connections on the back of the controller (Pins 11 and 12. See schematic at end of manual).
		Replace probe.
HA alternating with freezer temperature	Maximum temperature alarm	Power off, wait 1 minute, power on.
		Check that the cabinet door seals properly.
		Check and clean the condenser filter and condenser.
		Verify condenser fan operation.
		Verify compressor operation.
LA alternating with freezer temperature	Minimum temperature alarm	Power off, wait 1 minute, power on.
		Check/replace compressor isolation relay.

Important! Do not change the temperature scale (Fahrenheit or Celsius) on the controller.



WARNING! All repairs must be performed by a qualified service technician with the main power supply to the machine disconnected. Failure to follow this instruction may result in electrocution. Contact your local authorized Taylor distributor for service.

Troubleshooting

The following is a list of possible problems that may occur, probable causes, and corrective action that may eliminate the problem. If, after performing the corrective action, the problem persists, call a service technician for assistance.

Problem	Possible Causes	Corrective Actions
No power.	Dispenser not plugged in.	Verify plug is in the outlet, the On/Off switch is on.
	Faulty electrical outlet.	Check the circuit breaker. Try plugging into another outlet.
	Faulty power cord or plug.	Have a qualified electrician test and/or replace the power cord.
Dispenser not reaching temperature (HA Alarm) or slow to cool.	Dirty or clogged condenser or condenser filter.	Clean condenser and condenser filter.
	Cabinet door not closing.	Verify hopper is properly installed.
		Check the door gasket, if damaged replace.
		Check for damage to the door.
	Outlet door not installed.	Install outlet door.
	Faulty probe.	Verify probe accuracy, calibrate probe.
Faulty Temperature Controller or refrigeration relay.	Call a service technician for assistance.	
Condensing unit problem.	Call a service technician for assistance.	
Dispenser temperature too cold (LA Alarm).	Check the compressor enabled LED on the controller.	If the compressor enabled LED is off and the compressor is running, suspect a stuck refrigeration relay or controller fault.
		If the compressor enabled LED is on and the temperature reading is below the set point, suspect the controller.
Not dispensing fries.	Hopper is empty.	Verify product is in the hopper.
	Fries are bridged in the hopper.	Redistribute fries to break up the bridge.
	Drum not turning.	Verify dispensing drum socket is not damaged.
		Verify the motor shaft is turning when the Dispenser switch is pressed. If not, suspect a faulty Dispenser switch, wiring, or a faulty drum motor. Call a service technician for assistance.
	Outlet door not opening.	Verify proper installation of outlet door.
Verify the door shaft is turning when the Dispenser switch is pressed. If not, suspect a faulty Dispenser switch, faulty relay PCB, wiring, or a faulty door motor. Call a service technician.		
Check for damage to the outlet door.		
Outlet door not closing.	Product caught in outlet.	Disassemble the outlet door and hopper.
Outlet door alignment arrow in closed position.	Dispenser turned on while outlet door removed.	To position the alignment arrow for door placement, first verify there are no fries in the hopper, then turn the Dispenser on and press the Dispenser button. While depressing the Dispenser button, shut off the On/Off switch. Alignment arrow should be in the proper position to install the outlet door.
Overfilling the baskets.	Missing diverter or installed incorrectly.	Re-assemble Hopper assembly.
	Drum continues to turn after the Dispenser button is released.	Verify Dispenser button is not sticking
		Suspect a faulty relay PCB. Call a service technician for assistance.

Part Identification

Dispenser Cabinet Assembly

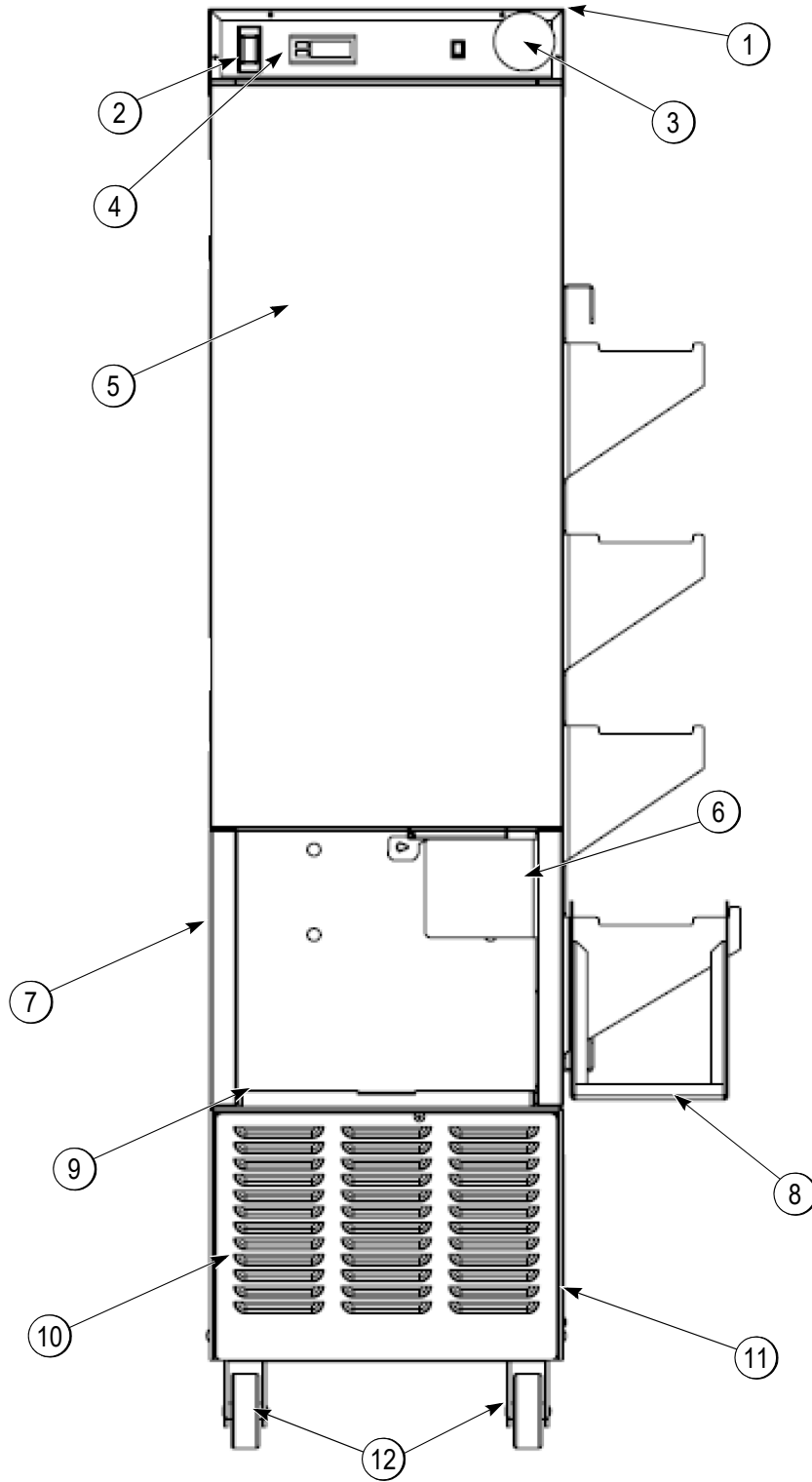

Figure-17

Item	Qty.	Part #	Description
1	1	296486	Top Cover
	4	213559	Screw, Truss Head, Phillips, #10-32x1/2"
	4	294092	Screw, Truss Head, Phillips
2	1	292246	On/Off Switch 15A
3	1	310193	Dispenser Switch
4	1	310082	Temperature Controller, Domestic (°F)
		310083	Temperature Controller, International (°C)
5	1	296444	Door Gasket
	2	293706	Hinge, Door
	4	293855	Screw, Truss Head, Phillips, 3/8-16x1/2"
6	1	296484	Support, Cabinet, Right
7	1	296483	Support, Cabinet, Left
8	1	296512	Kit, Basket Rack, Side Mount
	1	296505	Basket Rack, Side Mount
	1	296506	Drip Tray
	2	296508	Support Pins, Basket Rack
9	1	310125	Drip Tray
		296671	Drip Tray Spacer
10	1	296480	Access Plate, Condenser Filter
	1	295845	Filter, Condenser
11	1	296581	Door, Side Access
	2	294092	Screw, Flat Head, Slotted, #8-32 x 1 In.
12	4	293434	Caster
	16	200774	Screw, Hex-Head 5/16-18x3/4"
	16	290012	Nut, Hex, 5/16-18
	16	216159	Washer, 5/16
Not shown	1	296533	Door Heater Wire (Dom.120V)
Not shown	1	296511	Label Set

Outlet Assembly



Figure-18

Item	Qty.	Part#	Description
1	1	296650	Outlet Door
2	1	310125	Drip Tray
3	1	296671	Drip Tray Divider

Interior Parts—Front View

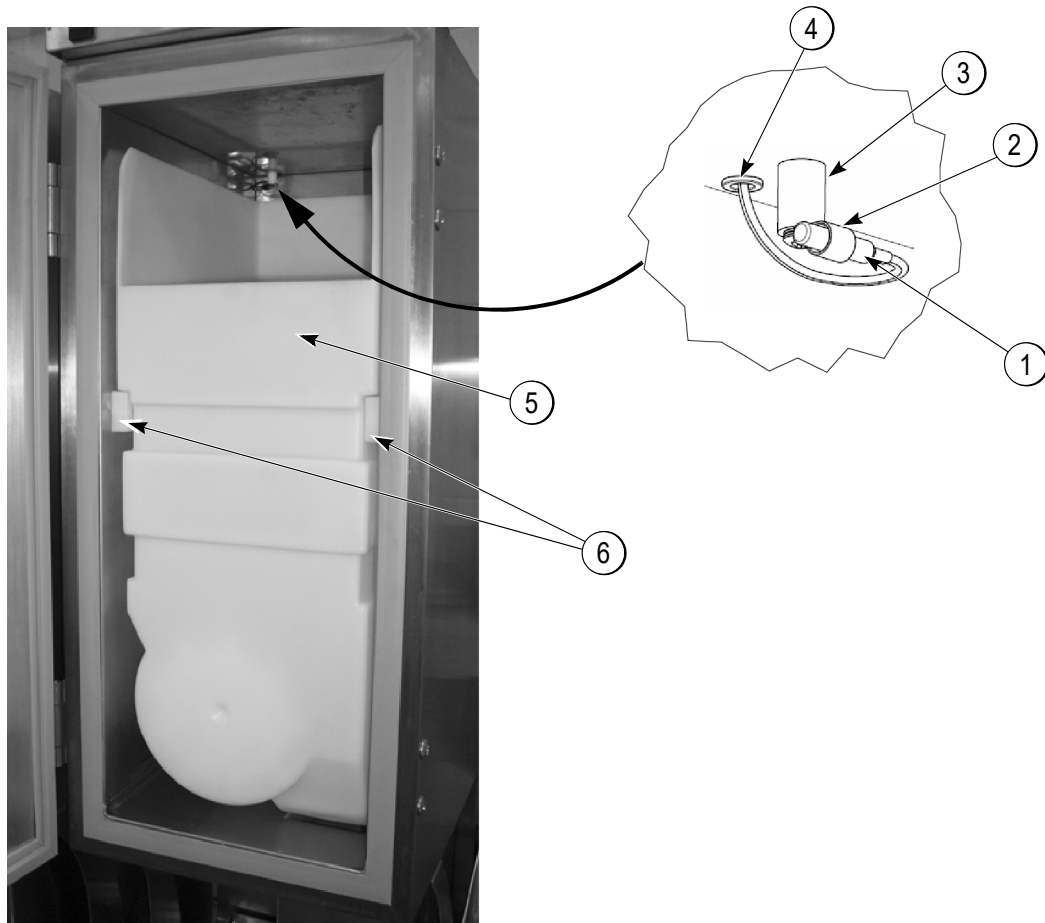

Figure-19

Item	Qty.	Part#	Description
1	1	291411	Probe, Temperature
2	1	291284	P-Clip
3	1	295234	Spacer
4	1	292058	Grommet
5	1	296525	Hopper
	1	296178	Diverter
	1	202366	Drum
6	4	295699	Hopper Support
		293720	Screw, FH, Slotted 10-32x1"
Not shown	1	293966	Rack, Hash Brown, Optional

Dispenser Cabinet Interior—Rear View

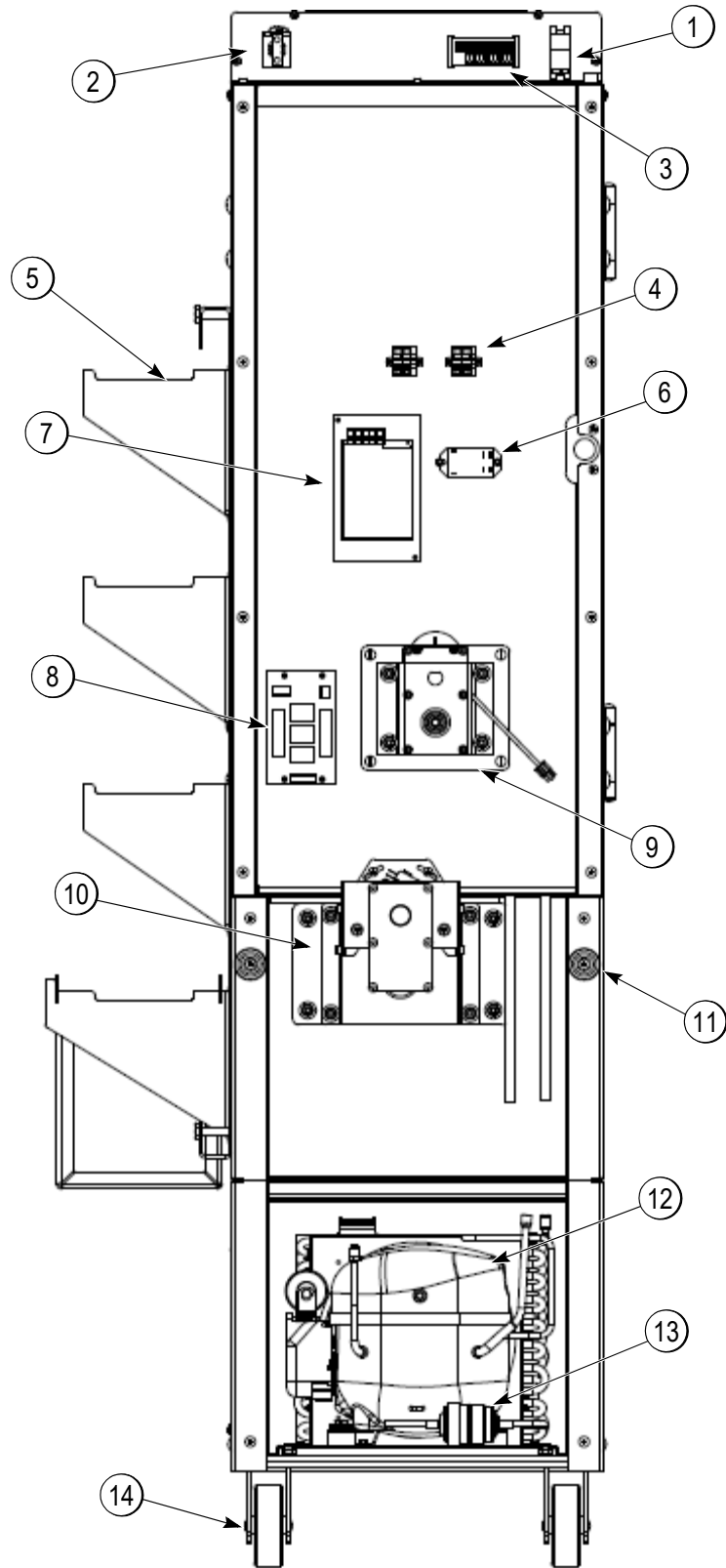

Figure-20

Item	Qty.	Part #	Description
1	1	292246	On/Off Switch
2	1	310193	Dispense Switch
3	1	310082	Controller, Temp., 24V, °F, Dom., 115V 60 Hz
		310083	Controller, Temp., 24V, °C, Intl., 220V 50 Hz
4	2	296579	Terminal Block
5	1	296512	Kit, Basket Rack, Side Mount
	1	296505	Basket Rack, Side Mount
	1	296506	Drip Tray
	2	296508	Support Pins, Basket Rack
6	1	293405	Refrigeration Relay
7	1	380051	Power Supply
8	1	380054	Kit, Relay Board (Replacement for 3 and 4 relay control boards)
9	1	See page 21	Drum Motor Assembly
10	1	See page 20	Outlet Door Assembly
11	1	295681	Kit, Bumper, Wall (set of 2)
12	1	294339	Compressor Dom. (120V 60 Hz, 1/2 hp)
		294723	Compressor Intl. (240V 50 Hz, 1/2 hp)
		296329	Compressor Intl. (240V 60 Hz, 1/2 hp)
13	1	292501	Filter Drier
14	4	293434	Caster
	16	200774	Screw, Hex-Head 5/16-18x3/4"
	16	290012	Nut, Hex, 5/16-18
	16	216159	Washer, 5/16
Not shown	1	293399	Power Cord (Dom.120V)
		294129	Power Cord (Int. 240V Euro)
Not shown	1	296487	Upper Back Panel
	1	295653	Handle, Plastic
	8	294824	Screw, Truss Head, #10-32 x 3/8"
Not shown	1	296482	Lower Back Panel
	1	295653	Handle, Plastic
	6	294824	Screw, Truss Head, #10-32 x 3/8"
Not shown	1	296572	Terminal Block, Lower
Not shown	1	296575	Harness, 120VAC / 220VAC power
Not shown	1	296576	Harness, 24VDC power

Operator Panel Components

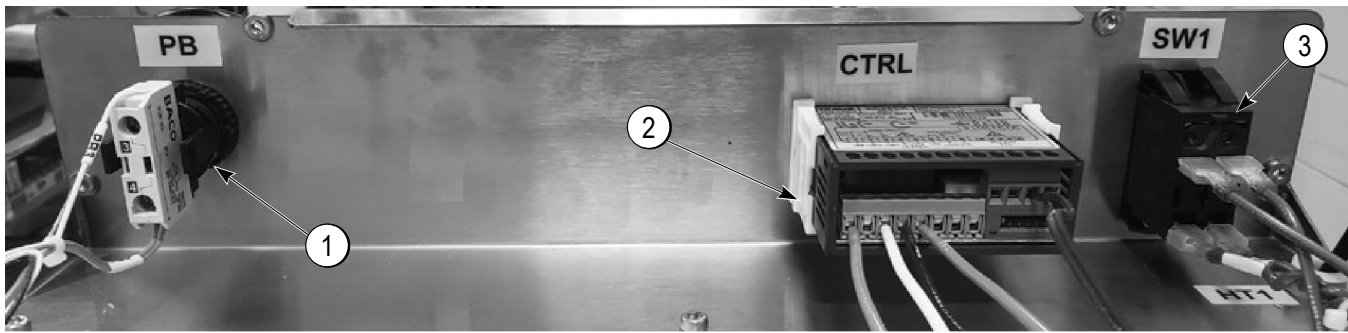

Figure-21

Item	Qty	Part#	Description
1	1	310193	Dispenser Button
2	1	310082 310083	Temperature Controller, Domestic (°F) Temperature Controller, International (°C)
3	1	292246	On/Off Switch
Not Shown	1	298533	Door Heater Wire

Outlet Door Assembly

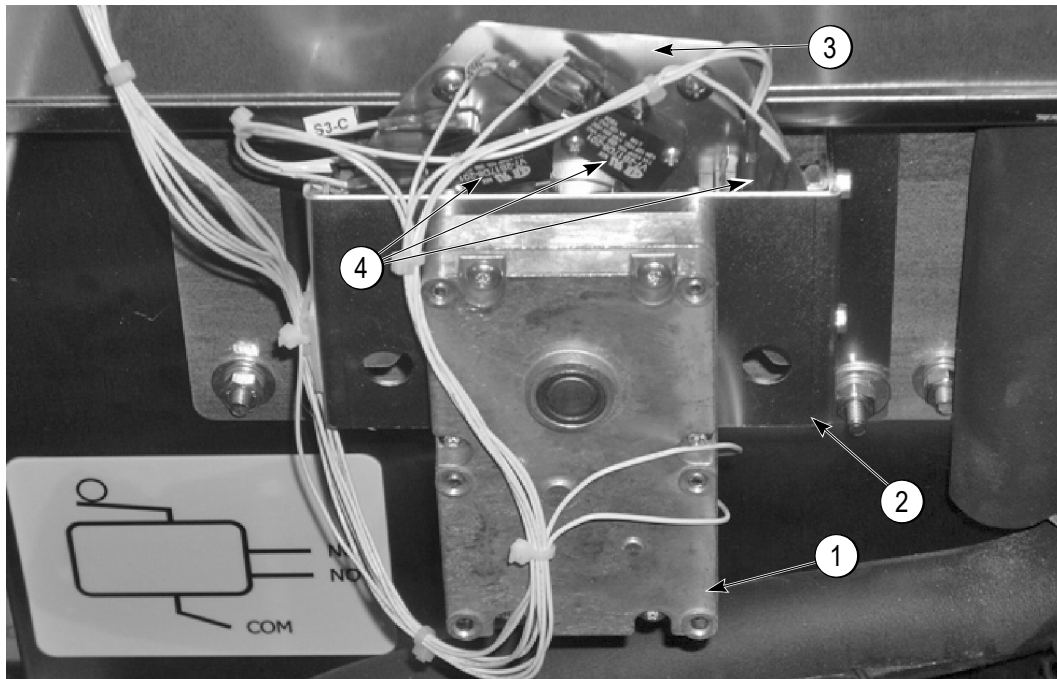

Figure-22

Item	Qty	Part#	Description	Item	Qty	Part#	Description
1	1	290133	Motor, Gear, 24 VDC	4	3	203249	Switch, Micro
2	1	296496	Bracket, Motor Mount	Not shown	1	296493	Shaft, Door Drive
3	1	296495	Plate, Switch Mount	Not shown	1	296500	Door Drive

Drum Motor Assembly

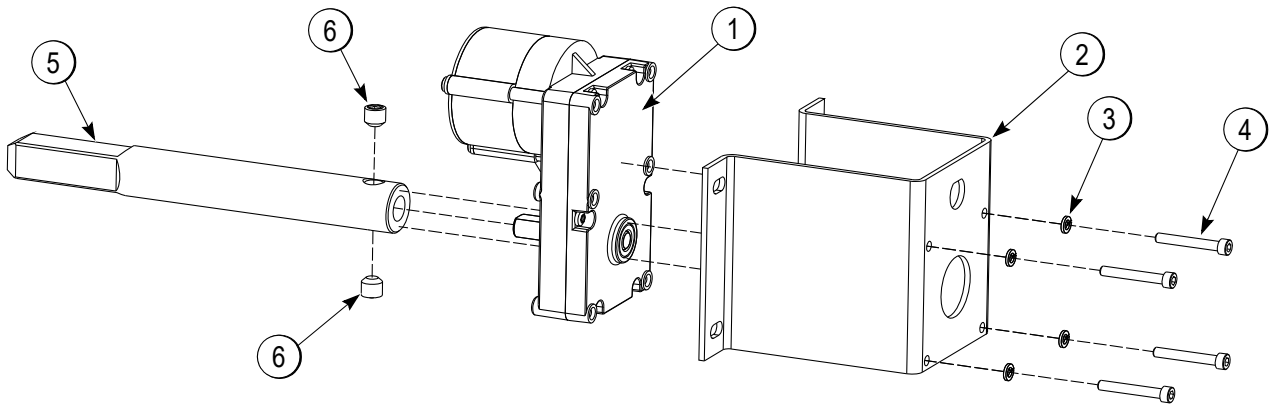

Figure-23

Item	Qty	Part#	Description	Item	Qty	Part#	Description
1	1	292546	Motor, Gear, Brushless, 24 VDC	4	4	213136	Cap Screw, Socket HD, #10-32x1¼"
2	1	202797	Bracket, Mount, Drum motor.	5	1	293318	Drum Shaft
3	4	213140	Washer, Lock, #10	6	2	290653	Set Screw, 3/8"-24 x 3/8"

Refrigeration System

General Operation

The R160 Space Saver employs a cold wall system. Through the refrigeration process, heat is transferred to the condensing unit at the bottom of the cabinet, where it is expelled to the surrounding outside air. It is extremely important to allow unrestricted airflow for the refrigeration process to function properly.

A minimum of 0.5 in. (13 mm) clearance on both sides and 2 in. (50 mm) behind the Dispenser is recommended.

The temperature control for the R160 is capable of detecting conditions that fall outside of normal operation. In such cases, the controller will generate and display an error to warn the operator that an abnormal condition exists and corrective action may need to be taken. Some error conditions are easily fixed, while others may require the attention of a qualified service technician.

See "Error Detection" on page-12 for a complete list of error codes and a troubleshooting guide.



CAUTION! Only trained and/or qualified personnel, licensed in refrigeration, should perform service to the refrigeration systems of this equipment. Failure to comply may result in personal injury from moving parts or damage to the machine.

The set point or turn off temperature is the temperature the refrigeration system will attempt to maintain inside the cabinet. The default set point temperature is 0°F (-18°C), and has a range of -10°F to 20°F (-23°C to -7°C). The set point can be changed using the SET key on the Temperature Controller. Cabinet temperature is displayed on the Temperature Controller display during normal operation.

Defrost

Because the Dispenser employs a cold wall design, it will be necessary to manually defrost the cabinet daily. First, remove the product. Turn the On/Off switch to the Off position. Remove baskets, hopper, outlet door, drip tray, and drip tray divider. Open the cabinet door and allow 1 hour to defrost.



CAUTION! Never use a sharp object to remove frost buildup. Never drill or otherwise puncture cabinet walls or top. Failure to follow this instruction may result in damage to the Dispenser.

Wipe the cabinet dry when defrosting is complete.

Required Maintenance

Daily

Shut off, clean, defrost, and inspect cabinet. (See "Daily Closing: Disassembly, Defrost, and Cleaning" on page-10.)

Monthly

Clean and inspect the condenser filter. Replace as necessary.

Every 3 Months

Or as needed as determined by environmental conditions.

Inspect the door gasket for proper sealing. Adjust door hinges and/or replace gasket if needed.

Clean the condenser coils, behind the condenser filter. See "Cleaning the Condenser Filter and Coil" on page-23.

Cleaning the Condenser Filter and Coil

Monthly cleaning of the condensing unit filter will aid the heat transfer characteristics of the refrigeration system, increase its efficiency, and extend the life of the compressor.

Remove the front louvered panel by removing the retaining screw. Lift and remove the louvered panel. Slide the condenser filter to the left and remove.

The filter can be cleaned in warm soapy water (**HCS**). Rinse and shake off the excess water. Replace the filter and access panel.

Every 3 months, clean the condenser coils. The coils are located behind the condenser filter. The condenser coils should be cleaned with a vacuum or a stiff brush.



CAUTION! Failure to keep the condenser filter and coil clean and clear of obstructions could result in temperature loss and damage to the compressor and may void the warranty.



CAUTION! Keep machine enclosure ventilation openings clear of obstructions, particularly in the back-bottom panel. Failure to comply may result in damage to the machine.

Refrigeration System Components

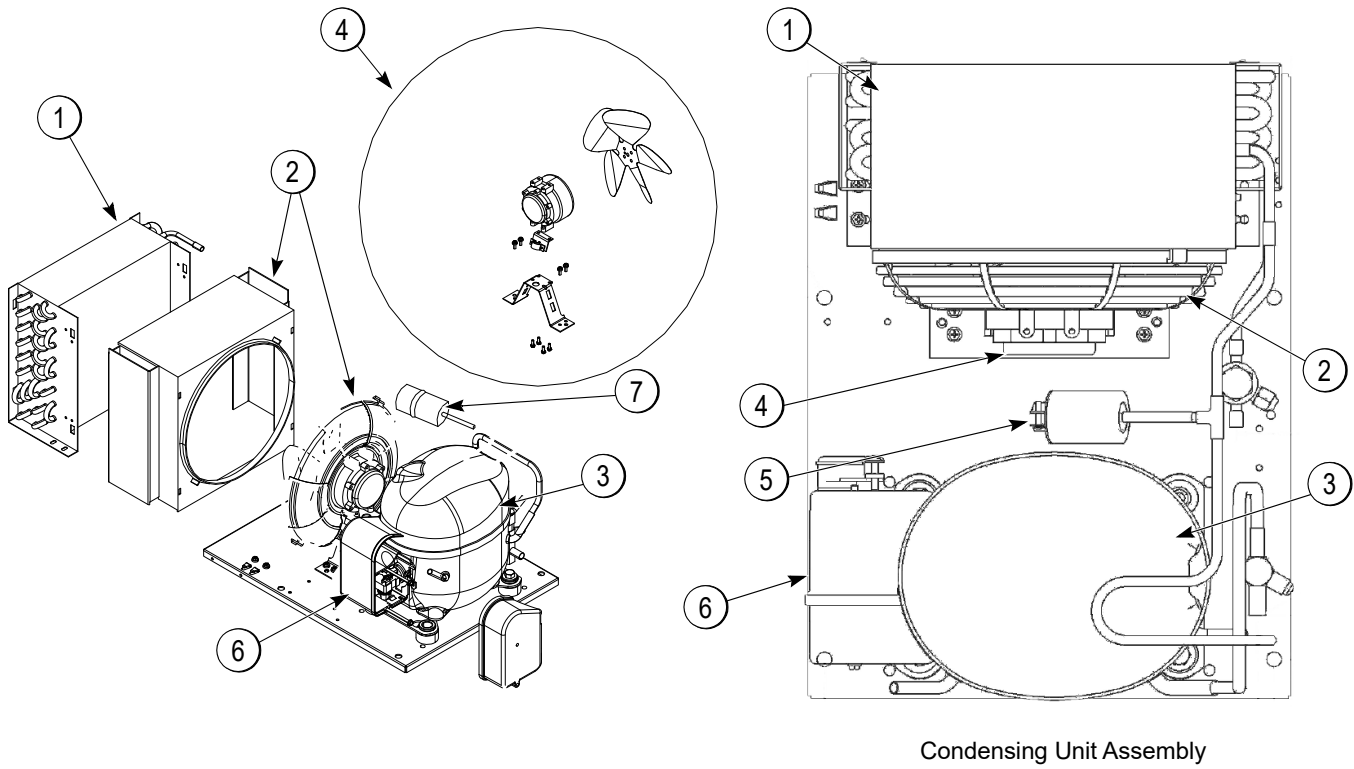

Figure-24

Item	Qty.	Part #	Description
1	1	295596	Condenser
2	1	295603	Fan Shroud
3	1	294339 294723 296329 295258	Compressor Dom. (120V 60 Hz , 1/2 hp 404A) Compressor Intl. (240V 50 Hz , 1/2 hp 404A) Compressor Intl. (240V 60 Hz , 1/2 hp 404A) Compressor Intl. (240V 50 Hz 1/2HP R290 only)
4	1 1 1	295773 295608 295601 293982	Condenser Fan Motor (Dom.120V) Condenser Fan Motor (Int. 240V) Blade, Condenser Fan Bracket, Condenser Fan
5	1	292740	High Pressure Switch
6	1	294739 294739 296606 295666	Overload Switch (1/2 hp Dom.120V 404A) Overload Switch (1/2 hp Int. 240V 50 Hz 404A) Overload Switch (1/2 hp Int. 240V 60 Hz 404A) Overload Switch, (Model R160, R290 only) (1/2 hp Int. 240V 50 Hz)
	1	294738 294780 296349 295667	Start Relay (1/2 hp Dom. 120V 404A) Start Relay (1/2 hp Int. 240V 50 Hz 404A) Start Relay (1/2 hp Int. 240V 60 Hz 404A) Start Relay, (Model R160, R290 only) (1/2 hp Int. 240V 50 Hz)
	1	293985 294779 296348 295665	Start Capacitor (1/2 hp Dom. 120V 404A) Start Capacitor (1/2 hp Int. 240V 50 Hz 404A) Start Capacitor (1/2 hp Int. 240V 60 Hz 404A) Start Capacitor (Model R160, R290 only) (1/2 hp Int. 240V 50 Hz)
7	1	292501	Filter Drier
Not Shown	1	293907 Per inch	Capillary Tube 86" (218 cm) 0.093" O.D., 0.040" I.D. (Domestic 120V 60Hz , 1/2 HP Comp.) Capillary Tube 105" (267 cm) 0.093" O.D., 0.040" I.D. (International 240V 50Hz , 1/2 HP Comp.) Capillary Tube 86" (218 cm) 0.093" O.D., 0.040" I.D. (International 240V 60Hz , 1/2 HP Comp.) Capillary Tube 122" (267 cm) 0.093" O.D., 0.040" I.D. (International 240V 50Hz , 1/2 HP Comp., R290 only)

Refrigeration Circuit (404A Refrigerant)

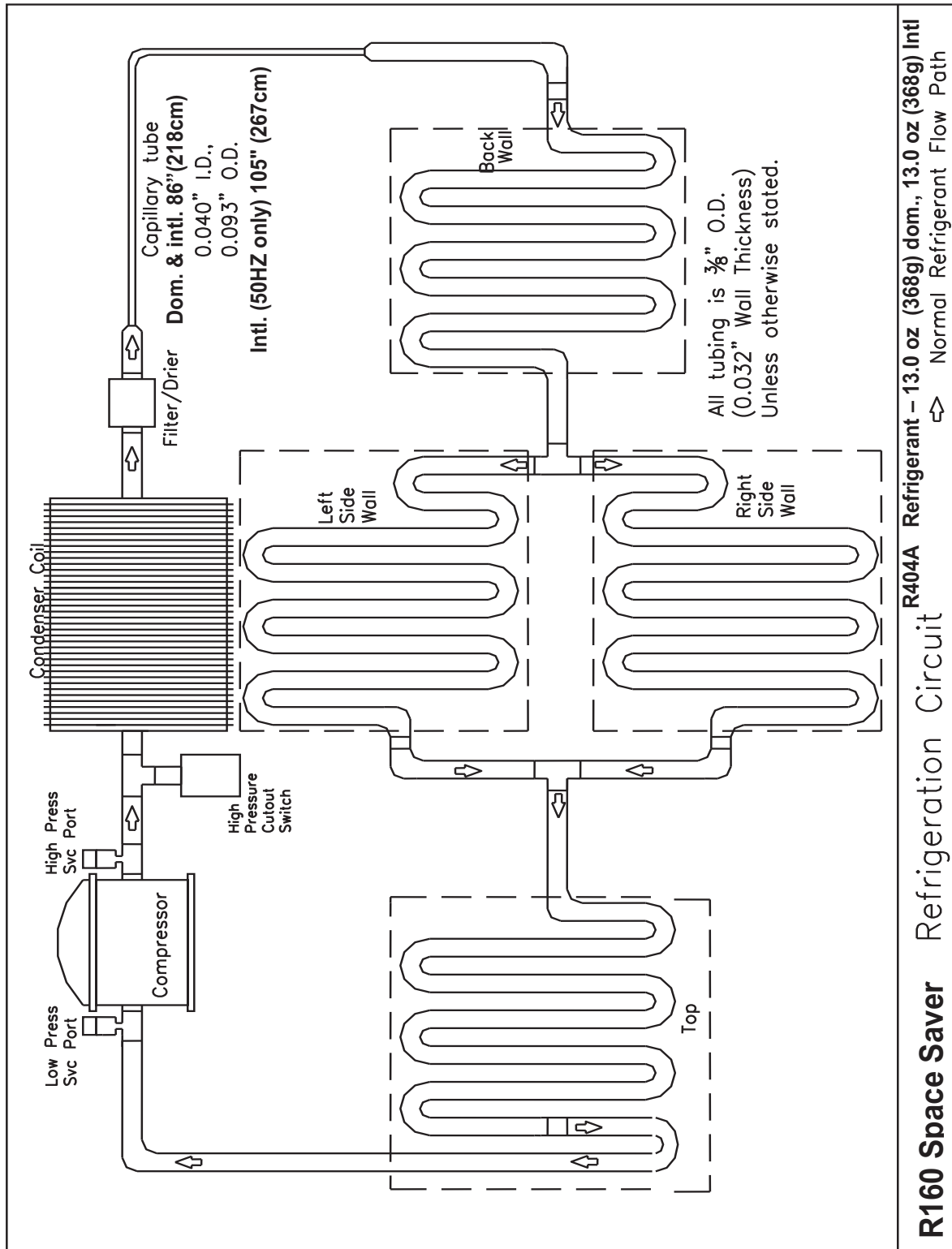

Figure-25

Refrigeration Circuit (R290 Refrigerant)

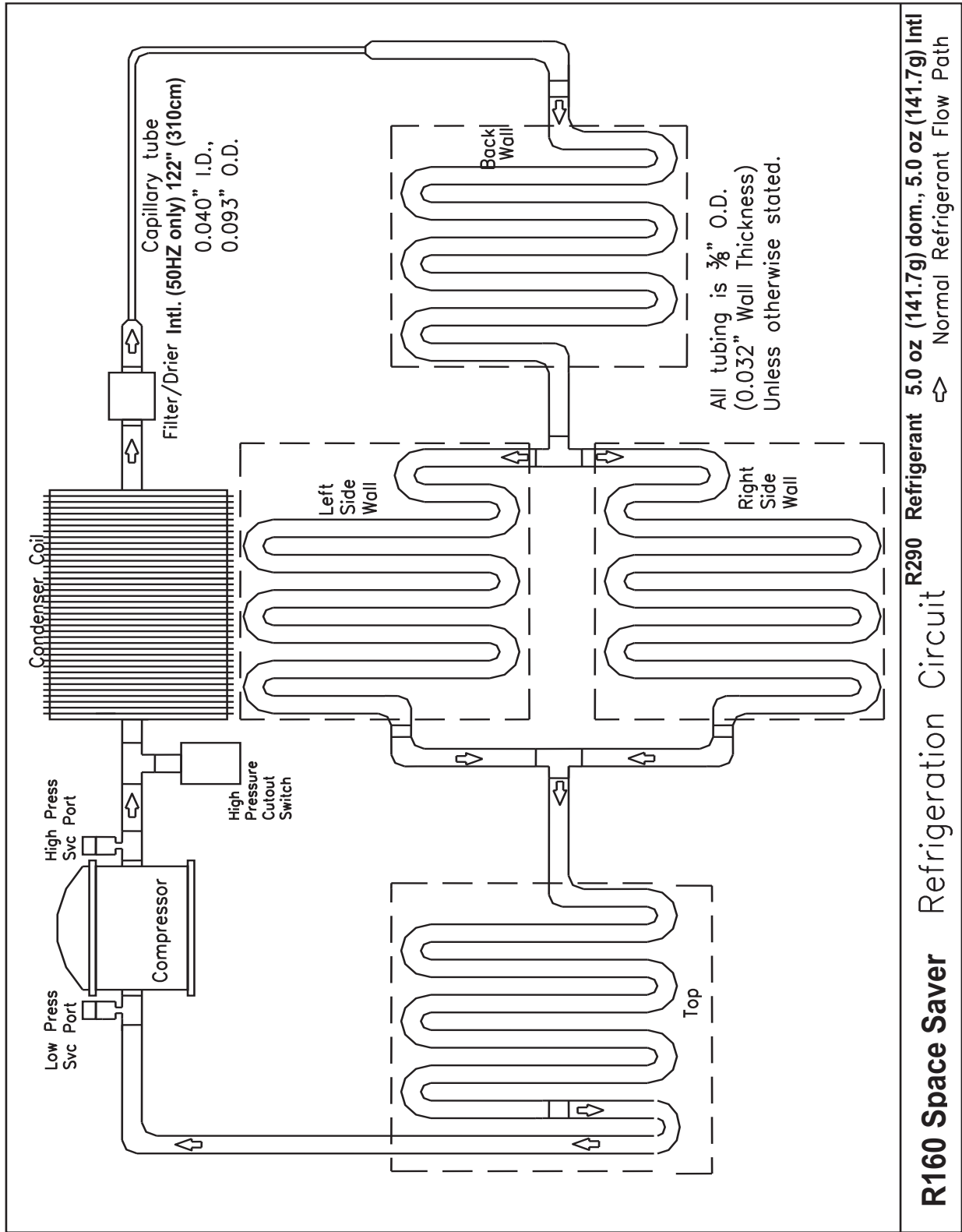

Figure-26

Electrical Diagram

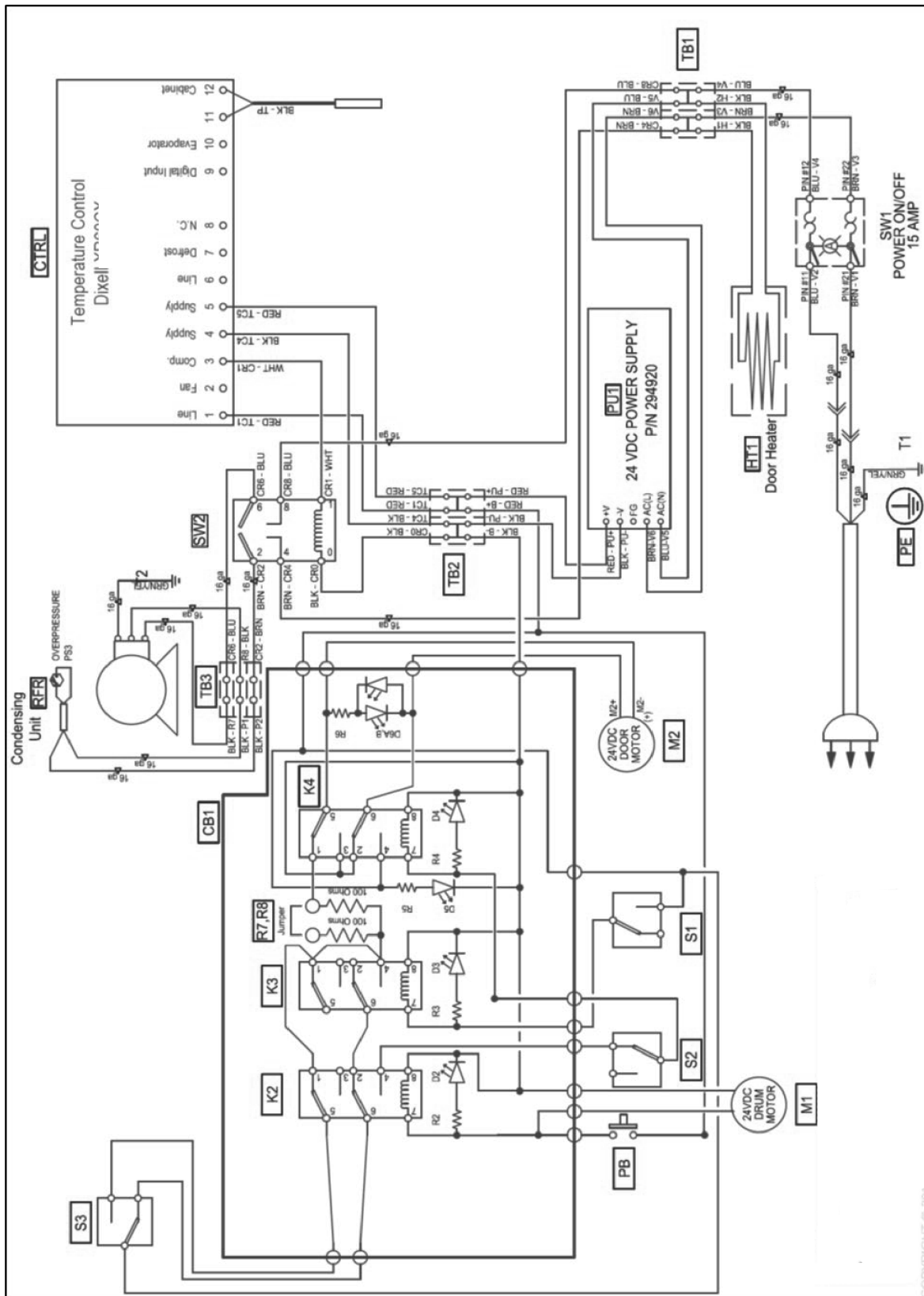

Figure-27

Electrical Diagram (with Replacement Controller)

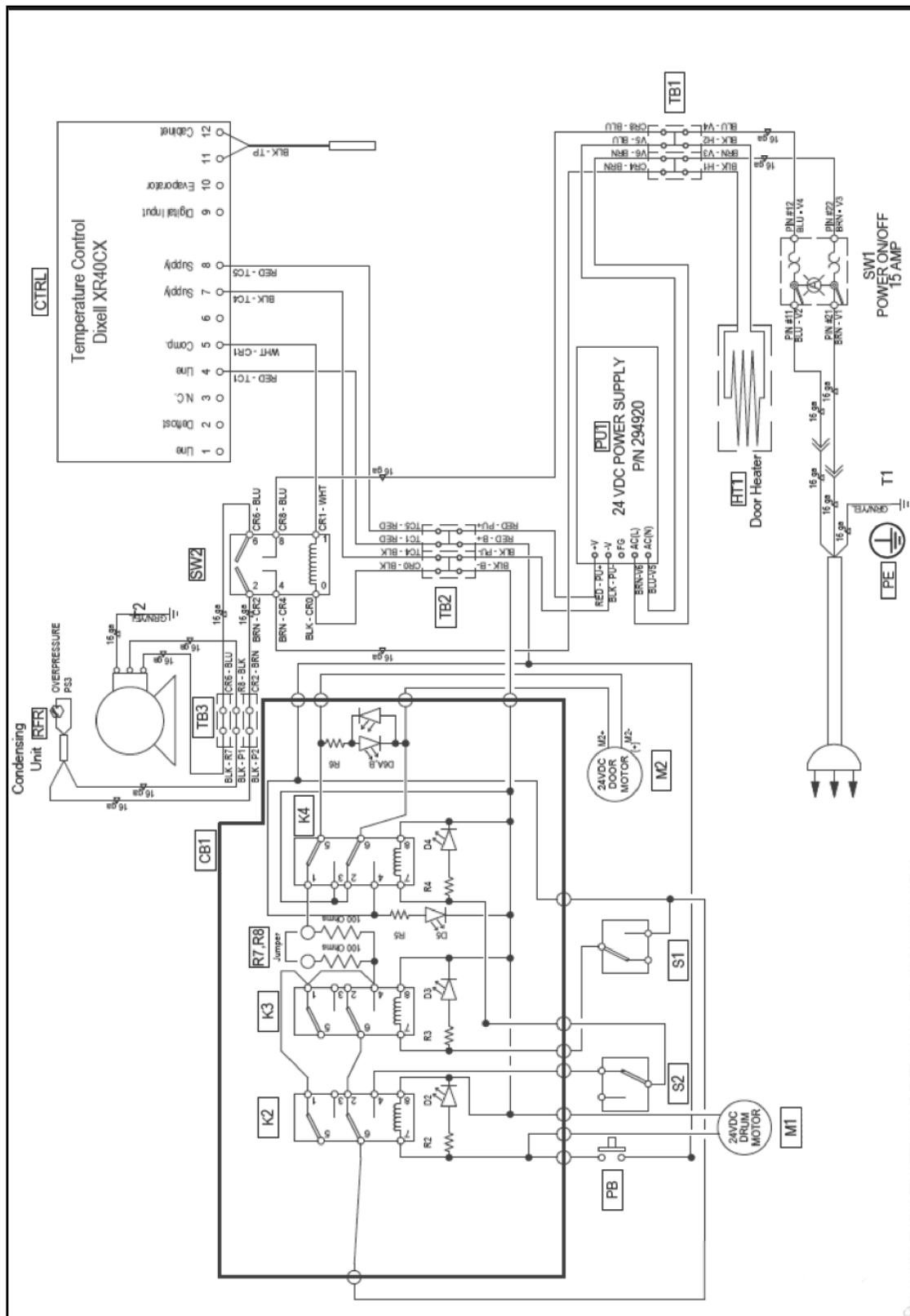

Figure-28

Limited Warranty on Equipment

TAYLOR COMPANY LIMITED WARRANTY ON FREEZERS

Taylor Company is pleased to provide this limited warranty on new Taylor-branded freezer equipment available from Taylor to the market generally (the "Product") to the original purchaser only.

LIMITED WARRANTY

Taylor warrants the Product against failure due to defect in materials or workmanship under normal use and service as follows. All warranty periods begin on the date of original Product installation. If a part fails due to defect during the applicable warranty period, Taylor, through an authorized Taylor distributor or service agency, will provide a new or remanufactured part, at Taylor's option, to replace the failed defective part at no charge for the part. Except as otherwise stated herein, these are Taylor's exclusive obligations under this limited warranty for a Product failure. This limited warranty is subject to all provisions, conditions, limitations, and exclusions listed below and on the reverse (if any) of this document.

Product	Part	Limited Warranty Period
R160	Refrigeration compressor (except service valve)	Five (5) years
	Parts not otherwise listed in this table or excluded below	Two (2) years

LIMITED WARRANTY CONDITIONS

1. If the date of original installation of the Product cannot be verified, then the limited warranty period begins thirty (30) days from the date of Product Shipment (as indicated by the Product serial number). Proof of purchase may be required at time of service.
2. This limited warranty is valid only if the Product is installed and all required service work on the Product is performed by an authorized Taylor distributor or service agency, and only if genuine, new Taylor parts are used.
3. Installation, use, care, and maintenance must be normal and in accordance with all instructions contained in the Equipment Manual.
4. Defective parts must be returned to the authorized Taylor distributor or service agency for credit.
5. The use of any refrigerant other than that specified on the Product's data label will void this limited warranty.

LIMITED WARRANTY EXCEPTIONS

This limited warranty does **not** cover:

1. Except as otherwise specifically set forth in this limited warranty, labor or other costs incurred for diagnosing, repairing, removing, installing, shipping, servicing, or handling of defective parts, replacement parts, or new Products.
2. Normal maintenance, cleaning, and lubrication as outlined in the Equipment Manual, including cleaning of condensers.
3. Replacement of wear items designated as Class "000" parts in the Equipment Manual.
4. External hoses, electrical power supplies, and machine grounding.
5. Parts not supplied or designated by Taylor, or damages resulting from their use.
6. Return trips or waiting time required because a service technician is prevented from beginning warranty service work promptly upon arrival.
7. Failure, damage, or repairs due to faulty installation, misapplication, abuse, no or improper servicing, unauthorized alteration, or improper operation or use as indicated in the Equipment Manual, including but not limited to the failure to use proper assembly and cleaning techniques, tools, or approved cleaning supplies.

-
8. Failure, damage, or repairs due to theft, vandalism, wind, rain, flood, high water, water, lightning, earthquake, or any other natural disaster, fire, corrosive environments, insect or rodent infestation, or other casualty, accident or condition beyond the reasonable control of Taylor; operation above or below the electrical or water supply specification of the Product; or components repaired or altered in any way so as, in the judgment of the Manufacturer, to adversely affect performance, or normal wear or deterioration.
 9. Failure to start due to voltage conditions, blown fuses, open circuit breakers, or damages due to the inadequacy or interruption of electrical service.
 10. Electricity or fuel costs, or increases in electricity or fuel costs from any reason whatsoever.
 11. Damages resulting from the use of any refrigerant other than that specified on the Product's data label will void this limited warranty.
 12. **ANY SPECIAL, INDIRECT, OR CONSEQUENTIAL PROPERTY OR COMMERCIAL DAMAGE OF ANY NATURE WHATSOEVER.** Some jurisdictions do not allow the exclusion of incidental or consequential damages, so this limitation may not apply to you.

This limited warranty gives you specific legal rights, and you may also have other rights which vary from jurisdiction to jurisdiction.

LIMITATION OF WARRANTY

THIS LIMITED WARRANTY IS EXCLUSIVE AND IS IN LIEU OF ALL OTHER WARRANTIES, CONDITIONS, AND/OR REMEDIES UNDER THE LAW, INCLUDING ANY IMPLIED WARRANTIES OR CONDITIONS OF MERCHANTABILITY OR FITNESS FOR A PARTICULAR PURPOSE. THE ORIGINAL OWNER'S SOLE REMEDY WITH RESPECT TO ANY PRODUCTS SHALL BE REPAIR OR REPLACEMENT OF DEFECTIVE COMPONENTS UNDER THE TERMS OF THIS LIMITED WARRANTY. ALL RIGHTS TO CONSEQUENTIAL OR INCIDENTAL DAMAGES (INCLUDING CLAIMS FOR LOST SALES, LOST PROFITS, PRODUCT LOSS, PROPERTY DAMAGES, OR SERVICE EXPENSES) ARE EXPRESSLY EXCLUDED. THE EXPRESS WARRANTIES MADE IN THIS LIMITED WARRANTY MAY NOT BE ALTERED, ENLARGED, OR CHANGED BY ANY DISTRIBUTOR, DEALER, OR OTHER PERSON, WHATSOEVER.

LEGAL REMEDIES

The owner **must** notify Taylor in writing, by certified or registered letter to the following address, of any defect or complaint with the Product, stating the defect or complaint and a specific request for repair, replacement, or other correction of the Product under warranty, mailed at least thirty (30) days before pursuing any legal rights or remedies.

Taylor Company
750 N. Blackhawk Blvd.
Rockton, IL 61072, U.S.A.

Limited Warranty on Parts

TAYLOR COMPANY LIMITED WARRANTY ON TAYLOR GENUINE PARTS

Taylor Company is pleased to provide this limited warranty on new Taylor genuine replacement components and parts available from Taylor to the market (the "Parts").

LIMITED WARRANTY

Taylor warrants the Parts against failure due to defect in materials or workmanship under normal use and service as follows. All warranty periods begin on the date of original installation of the Part in the Taylor unit. If a Part fails due to defect during the applicable warranty period, Taylor, through an authorized Taylor distributor or service agency, will provide a new or remanufactured Part, at Taylor's option, to replace the failed defective Part at no charge for the Part. Except as otherwise stated herein, these are Taylor's exclusive obligations under this limited warranty for a Part failure. This limited warranty is subject to all provisions, conditions, limitations, and exclusions listed below and on the reverse (if any) of this document.

Parts Warranty Class Code or Part	Limited Warranty Period
Class 103 Parts	Three (3) months
Class 212 Parts	Twelve (12) months
Class 512 Parts	Twelve (12) months
Class 000 Parts	No warranty

LIMITED WARRANTY CONDITIONS

1. If the date of original installation of the Part cannot be otherwise verified, proof of purchase may be required at time of service.
2. This limited warranty is valid only if the Part is installed and all required service work in connection with the Part is performed by an authorized Taylor distributor or service agency.
3. The limited warranty applies only to Parts remaining in use by their original owner at their original installation location in the unit of original installation.
4. Installation, use, care, and maintenance must be normal and in accordance with all instructions contained in the Taylor Operator's Manual.
5. Defective Parts must be returned to the authorized Taylor distributor or service agency for credit.
6. This warranty is not intended to shorten the length of any warranty coverage provided pursuant to a separate Taylor Limited Warranty on freezer or grill equipment.
7. The use of any refrigerant other than that specified for the unit in which the Part is installed will void this limited warranty.

LIMITED WARRANTY EXCEPTIONS

This limited warranty does **not** cover:

1. Labor or other costs incurred for diagnosing, repairing, removing, installing, shipping, servicing, or handling of defective Parts, replacement Parts, or new Parts.
2. Normal maintenance, cleaning, and lubrication as outlined in the Taylor Operator's Manual, including cleaning of condensers or carbon and grease buildup.
3. Required service, whether cleaning or general repairs, to return the cooking surface assemblies, including the upper platen and lower plate, to an operational condition to achieve proper cooking or allow proper assembly of release sheets and clips as a result of grease buildup on the cooking surfaces, including but not limited to the platen and plate, sides of the shroud or top of the shroud.
4. Replacement of cooking surfaces, including the upper platen and lower plate, due to pitting or corrosion (or in the case of the upper platen, due to loss of plating) as a result of damage due to the impact of spatulas or other small wares used during the cooking process or as a result of the use of cleaners, cleaning materials, or cleaning processes not approved for use by Taylor.
5. Replacement of wear items designated as Class "000" Parts in the Taylor Operator's Manual, as well as any release sheets and clips for the Product's upper platen assembly.
6. External hoses, electrical power supplies, and machine grounding.
7. Parts not supplied or designated by Taylor, or damages resulting from their use.
8. Return trips or waiting time required because a service technician is prevented from beginning warranty service work promptly upon arrival.
9. Failure, damage, or repairs due to faulty installation, misapplication, abuse, no or improper servicing, unauthorized alteration, or improper operation or use as indicated in the Taylor Operator's Manual, including but not limited to the failure to use proper assembly and cleaning techniques, tools, or approved cleaning supplies.
10. Failure, damage, or repairs due to theft, vandalism, wind, rain, flood, high water, water, lightning, earthquake, or any other natural disaster, fire, corrosive environments, insect or rodent infestation, or other casualty, accident or condition beyond the reasonable control of Taylor; operation above or below the gas, electrical, or water supply specification of the unit in which a part is installed; or Parts or the units in which they are installed repaired or altered in any way so as, in the judgment of Taylor, to adversely affect performance, or normal wear or deterioration.
11. Failure to start due to voltage conditions, blown fuses, open circuit breakers, or damages due to the inadequacy or interruption of electrical service.
12. Electricity, gas, or other fuel costs, or increases in electricity or fuel costs from any reason whatsoever.
13. Damages resulting from the use of any refrigerant other than that specified for the unit in which the Part is installed will void this limited warranty.
14. Any cost to replace, refill, or dispose of refrigerant, including the cost of refrigerant.
15. **ANY SPECIAL, INDIRECT, OR CONSEQUENTIAL PROPERTY OR COMMERCIAL DAMAGE OF ANY NATURE WHATSOEVER.** Some jurisdictions do not allow the exclusion of incidental or consequential damages, so this limitation may not apply to you.

This limited warranty gives you specific legal rights, and you may also have other rights which vary from jurisdiction to jurisdiction.

LIMITATION OF WARRANTY

THIS LIMITED WARRANTY IS EXCLUSIVE AND IS IN LIEU OF ALL OTHER WARRANTIES, CONDITIONS, AND/OR REMEDIES UNDER THE LAW, INCLUDING ANY IMPLIED WARRANTIES OR CONDITIONS OF MERCHANTABILITY OR FITNESS FOR A PARTICULAR PURPOSE. THE ORIGINAL OWNER'S SOLE REMEDY WITH RESPECT TO ANY PRODUCTS SHALL BE REPAIR OR REPLACEMENT OF DEFECTIVE PARTS UNDER THE TERMS OF THIS LIMITED WARRANTY. ALL RIGHTS TO CONSEQUENTIAL OR INCIDENTAL DAMAGES (INCLUDING CLAIMS FOR LOST SALES, LOST PROFITS, PRODUCT LOSS, PROPERTY DAMAGES, OR SERVICE EXPENSES) ARE EXPRESSLY EXCLUDED. THE EXPRESS WARRANTIES MADE IN THIS LIMITED WARRANTY MAY NOT BE ALTERED, ENLARGED, OR CHANGED BY ANY DISTRIBUTOR, DEALER, OR OTHER PERSON, WHATSOEVER.

LEGAL REMEDIES

The owner **must** notify Taylor in writing, by certified or registered letter to the following address, of any defect or complaint with the Part, stating the defect or complaint and a specific request for repair, replacement, or other correction of the Part under warranty, mailed at least thirty (30) days before pursuing any legal rights or remedies.

Taylor Company
750 N. Blackhawk Blvd.
Rockton, IL 61072, U.S.A.

Ordering/Service Information

Taylor distributor: _____

Address: _____

Phone: _____

Date of installation: _____

Data Label

The data label provides necessary information that the operator should record and refer to when calling for parts or service. The data label is located on the rear or left side panel of the freezer.

Complete for quick reference when this information is requested.

1. Model Number: R160
2. Serial Number _____
3. Electrical Specs:
Voltage _____ Cycle _____ Phase _____
4. Maximum Fuse Size: _____ Amps
5. Minimum Wire Ampacity: _____ Amps
6. Part Number: _____

Parts Warranty

See the Limited Warranty on Parts section starting on page 32.

Note: *Constant research results in steady improvements; therefore, information in this manual is subject to change without notice.*

Compressor Warranty Disclaimer

The refrigeration compressor(s) on this unit are warranted for the term stated in the Limited Warranty section in this manual. However, due to the Montreal Protocol and the U.S. Clean Air Act Amendments of 1990, many new refrigerants are being tested and developed, thus seeking their way into the service industry. Some of these new refrigerants are being advertised as drop-in replacements for numerous applications. It should be noted that in the event of ordinary service to this unit's refrigeration system, **only the refrigerant specified on the affixed data label should be used.** The unauthorized use of alternate refrigerants will void your Taylor compressor warranty. It is the unit owner's responsibility to make this fact known to any technician he/she employs.

It should also be noted that Taylor does not warrant the refrigerant used in its equipment. For example, if the refrigerant is lost during the course of ordinary service to this unit, Taylor has no obligation to either supply or provide replacement refrigerant either at billable or unbillable terms. Taylor will recommend a suitable replacement if the original refrigerant is banned, obsoleted, or no longer available during the five-year Taylor warranty of the compressor.

From time-to-time Taylor may test new refrigerant alternates. Should a new refrigerant alternate prove, through Taylor's testing, that it would be accepted as a drop-in replacement for this unit, then the disclaimer in this "Compressor Warranty Disclaimer" section will not apply to the use of the alternate refrigerant approved by Taylor.

To find out the current status of an alternate refrigerant as it relates to your compressor warranty, call Taylor or your local authorized Taylor distributor. Be prepared to provide the model/serial number of the machine in question.

Note: *Continuing research results in steady improvements; therefore, information in this Operator's Manual is subject to change without notice.*

Service Information

Warranty Service

Our Distributor will determine the cause of failure and provide appropriate resolution. Any required replacement parts will be provided by us or by an authorized Service Support Center/Parts Distributor.

Our Distributor will make all reasonable efforts to perform such repairs during normal business hours, and will not be responsible for any after-hours or holiday charges.

Non-Warranty Service

Service is normally conducted by customer appointed personnel, or by contracting a local service technician. The service technician must be licensed in refrigeration to troubleshoot, open, or repair refrigeration and related systems.

Service fees are in accordance with industry standards.

Replacement parts are available through an authorized Taylor distributor or service agency.

Our authorized Taylor distributor or service agency is available for assistance providing product technical support, parts and parts information, and service agent referral.

Record the following information for your records:

Date of Installation

Service Agency Telephone

Serial Number

When repairing this machine, use only replacement parts supplied by us or supplied by our factory-authorized parts distributor. Use of replacement parts other than those supplied by us or by our factory-authorized parts distributor will void the warranty.

All shipping charges are F.O.B. factory, and are subject to change without notice. Prices will be those in affect at the time of shipment.

Taylor Company reserves the right to make suitable substitutions in materials, depending upon their availability.

CAUTION!

Only trained and/or qualified personnel should perform service on this equipment.
Only trained and/or qualified personnel, licensed in refrigeration, should perform service on the refrigeration systems of this equipment.
Service functions described in this manual could cause irreversible damage to the equipment and/or injury to personnel if performed improperly.
If the power cord is damaged, it must be replaced by the manufacturer, or its service agent, or a similarly qualified person to prevent a hazard.
Use of non-OEM parts may create a hazard.