

OPERATOR'S MANUAL



Model C713 Soft Serve Freezer

Original Operating Instructions

062180-M

2/11/05 (Original Publication)
(Updated 8/19/2020)

Section 1: To the Installer

Installer Safety	1-1
Site Preparation	1-1
Air-Cooled Units	1-1
Water Connections (Water-Cooled Units Only)	1-2
Electrical Connections.....	1-2
Beater Rotation	1-3
Refrigerant	1-3

Section 2: To the Operator

Compressor Warranty Disclaimer	2-2
--------------------------------------	-----

Section 3: Safety

Section 4: Operator Parts Identification

Model C713.....	4-1
Model C713 Door and Beater Assembly.....	4-3
Accessories.....	4-4
Brushes.....	4-5

Section 5: User Interface

Symbol Definitions	5-2
Operating Screen Descriptions	5-4
Manager's Menu	5-5

Section 6: Operating Procedures

Freezing Cylinder Assembly	6-1
Sanitizing.....	6-5
Priming.....	6-6
Closing Procedure.....	6-6
Draining Product from the Freezing Cylinder	6-6
Rinsing	6-7
Hopper Cleaning	6-7
Disassembly.....	6-7
Manual Brush Cleaning.....	6-8

Section 7: Operator Checklist

During Cleaning and Sanitizing.....	7-1
Troubleshooting Bacterial Count.....	7-1
Regular Maintenance Checks	7-1
Winter Storage	7-2

Table of Contents

Section 8: Troubleshooting Guide

Section 9: Parts Replacement Schedule

Section 10: Limited Warranty on Equipment

Section 11: Limited Warranty on Parts

The following information has been included in the manual as safety and regulatory guidelines. For complete installation instructions, please see the Installation Checklist.

Installer Safety



IMPORTANT! In all areas of the world, equipment should be installed in accordance with existing local codes. Please contact your local authorities if you have any questions.

Care should be taken to ensure that all basic safety practices are followed during the installation and servicing activities related to the installation and service of Taylor equipment.

- Only authorized Taylor service personnel should perform installation and repairs on the equipment.
- Authorized service personnel should consult OSHA Standard 29CFR1910.147 or the applicable code of the local area for the industry standards on lockout/tagout procedures before beginning any installation or repairs.
- Authorized service personnel must ensure that the proper PPE is available and worn when required during installation and service.
- Authorized service personnel must remove all metal jewelry, rings, and watches before working on electrical equipment.



DANGER! The main power supply(s) to the freezer must be disconnected prior to performing any repairs. Failure to follow this instruction may result in personal injury or death from electrical shock or hazardous moving parts as well as poor performance or damage to the equipment.

Note: All repairs must be performed by an authorized Taylor service technician.



WARNING! This unit has many sharp edges that can cause severe injuries.



WARNING! Only install this machine in a location where its use and maintenance is restricted to trained personnel. Failure to comply may result in personal injury.

Site Preparation

Review the area the unit is to be installed in before uncrating the unit. Make sure that all possible hazards the user or equipment may encounter have been addressed.

Air-Cooled Units

The Model C713 air-cooled unit requires a minimum of 3 in. (76 mm) of clearance on all sides. Install the deflector provided to prevent recirculation of warm air. This will allow for adequate air flow across the condenser. Failure to allow adequate clearance can reduce the refrigeration capacity of the freezer and possibly cause permanent damage to the compressor.

For Indoor Use Only: This unit is designed to operate indoors, under normal ambient temperatures of 70°F to 75°F (21°C to 24°C). The freezer has successfully performed in high ambient temperatures of 104°F (40°C) at reduced capacities.



WARNING! DO NOT install the units in an area where a water jet could be used. Failure to follow this instruction may result in serious electrical shock.



CAUTION! This unit must be installed on a level surface to avoid the hazard of tipping. Extreme care

TO THE INSTALLER

should be taken in moving this equipment for any reason. Two or more persons are required to safely move this unit. Failure to comply may result in personal injury or equipment damage.

1

Uncrate the unit and inspect it for damage. Report any damage to your Taylor distributor.

This piece of equipment is made in the USA and has USA sizes of hardware. All metric conversions are approximate and vary in size.

Water Connections

(Water-Cooled Units Only)

An adequate cold water supply must be provided with a hand shutoff valve. On the underside of the base pan or on the right side, two 3/8 in. I.P.S. water connections for inlet and outlet are provided for easy hookup. Permanently connect the machine using 1/2 in. (12.7 mm) inside diameter water lines. (Flexible lines are recommended, if local codes permit.) Depending on local water conditions, it may be advisable to install a water strainer to prevent foreign substances from clogging the automatic water valve. There will be only one water in and one water out connection. **Do not** install a hand shutoff valve on the water out line. Water should always flow in this order: first, through the automatic water valve; second, through the condenser; and third, through the outlet fitting to an **open trap drain**.



IMPORTANT! A backflow prevention device is required on the incoming water connection side. Please see the applicable national, state, and local codes for determining the proper configuration. Water pressure to the unit must not exceed 150 psi (1034 kPa).

Electrical Connections

In the United States, this equipment is intended to be installed in accordance with the National Electrical Code (NEC), ANSI/NFPA 70-1987. The purpose of the NEC code is the practical safeguarding of persons and property from hazards arising from the use of electricity. This code contains provisions considered necessary for safety. In all other areas of the world, equipment should be installed in accordance with the existing local codes.

Please contact your local authorities.



FOLLOW YOUR LOCAL ELECTRICAL CODES.

Each unit requires one power supply for each data label on the unit. Check the data label(s) on the freezer for branch circuit overcurrent protection or fuse, circuit ampacity, and other electrical specifications. Refer to the wiring diagram provided inside the electrical box for proper power connections.



WARNING! This equipment must be properly grounded! **DO NOT** operate this freezer unless it is properly grounded and all service panels and access doors are restrained with screws. Failure to do so can result in severe personal injury from electrical shock!



WARNING! DO NOT operate this freezer with larger fuses than specified on the unit data label. Failure to follow this instruction may result in electrocution or damage to the machine.



IMPORTANT! This unit is provided with an equipotential grounding lug that is to be properly attached to the rear of the frame by the authorized installer. The installation location is marked by the equipotential bonding symbol (5021 of IEC 60417- 1) on the removable panel and the frame.



NOTICE! Stationary appliances which are not equipped with a power cord and a plug or another device to disconnect the appliance from the power source must have an all-pole disconnecting device with a contact gap of at least 0.125 in. (3 mm) installed in the external installation.



IMPORTANT! Appliances that are permanently connected to fixed wiring and for which leakage currents may exceed 10 mA, particularly when disconnected or not used for long periods, or during initial installation, shall have protective devices to protect against the leakage of current, such as a GFI, installed by the authorized personnel to the local codes.



NOTICE! Supply cords used with this unit shall be oil-resistant, sheathed flexible cable not lighter than ordinary polychloroprene or other equivalent synthetic elastomer-sheathed cord (code designation 60245 IEC 57) installed with the proper cord anchorage to relieve conductors from strain, including twisting, at the terminals and protect the insulation of the conductors from abrasion.

If the supply cord is damaged, it must be replaced by the manufacturer, its service agent, or similarly qualified person, in order to avoid a hazard.

Beater Rotation



Beater rotation must be clockwise as viewed looking into the freezing cylinder.

Note: The following procedures should be performed by a trained service technician.

To correct the rotation on a three-phase unit, interchange any two incoming power supply lines at the freezer main terminal block only.

To correct the rotation on a single-phase unit, change the leads inside the beater motor. (Follow the diagram printed on the motor.)

Electrical connections are made directly to the terminal block provided in the splice box.

Refrigerant



CAUTION! This machine contains fluorinated

greenhouse gases (F-Gas) to provide refrigeration using a hermetically sealed circuit or within foam insulation. This machine's type of gas, quantity, Global Warming Potential (GWP) and CO2 tonnes equivalent information is recorded on the machine's data label. The refrigerant used is generally considered nontoxic and nonflammable. However any gas under pressure is potentially hazardous and must be handled with caution.

NEVER fill any refrigerant cylinder completely with liquid. Filling the cylinder to approximately 80% will allow for normal expansion.



CAUTION! Use only approved refrigerant listed on the machine's data label or authorized through a manufacturer's technical bulletin. The use of any other refrigerant may expose users and operators to unexpected safety hazards.



WARNING! Refrigerant liquid sprayed onto the skin may cause serious damage to tissue. Keep eyes and skin protected. If refrigerant burns should occur, flush immediately with cold water. If burns are severe, apply ice packs and contact a physician immediately.



IMPORTANT! Taylor reminds technicians to be aware of government laws regarding refrigerant recovery, recycling, and reclaiming systems. If you have any questions regarding these laws, please contact the factory service department.



IMPORTANT! Refrigerants and their associated lubricants may be extremely moisture absorbent. When opening a refrigeration system, the maximum time the system is open must not exceed 15 minutes. Cap all open tubing to prevent humid air or water from being absorbed by the oil.

Your freezer has been carefully engineered and manufactured to give you dependable operation.

This unit, when properly operated and cared for, will produce a consistent quality product. Like all mechanical products, the freezer requires cleaning and maintenance. A minimum amount of care and attention is necessary if the operating procedures outlined in this manual are followed closely.



IMPORTANT! *This manual should be read before operating or performing any maintenance on your equipment.*

Your Taylor freezer will not eventually compensate for and correct any errors during the setup or filling operations. Thus, the initial assembly and priming procedures are of extreme importance. It is strongly recommended that personnel responsible for the equipment's operation, both assembly and disassembly, go through these procedures together in order to be properly trained and to make sure that no confusion exists.

If you require technical assistance, please contact your local authorized Taylor distributor.

Note: *Your Taylor warranty is valid only if the parts are authorized Taylor parts, purchased from the local authorized Taylor distributor, and only if all required service work is provided by an authorized Taylor service technician. Taylor reserves the right to deny warranty claims on units or parts if Taylor-unapproved parts or incorrect refrigerant were installed in the unit, system modifications were performed beyond factory recommendations, or it is determined that the failure was caused by abuse, misuse, neglect, or failure to follow all operating instructions. For full details of your Taylor warranty, please see the limited warranty section in this manual.*

Note: *Constant research results in steady improvements; therefore, information in this manual is subject to change without notice.*



If the crossed-out wheeled-bin symbol is affixed to this product, it signifies that this product is compliant with the EU Directive as well as other similar legislation in effect after August 13, 2005. Therefore, it must be collected separately after its use is completed, and cannot be disposed as unsorted municipal waste.

The user is responsible for returning the product to the appropriate collection facility, as specified by your local code.

For additional information regarding applicable local laws, contact the municipal facility and/or local distributor.

Compressor Warranty Disclaimer

The refrigeration compressor(s) on this unit are warranted for the term stated in the Limited Warranty section in this manual. However, due to the Montreal Protocol and the U.S. Clean Air Act Amendments of 1990, many new refrigerants are being tested and developed, thus seeking their way into the service industry. Some of these new refrigerants are being advertised as drop-in replacements for numerous applications. It should be noted that in the event of ordinary service to this unit's refrigeration system, **only the refrigerant specified on the affixed data label should be used.** The unauthorized use of alternate refrigerants will void your Taylor compressor warranty. It is the unit owner's responsibility to make this fact known to any technician he employs.

It should also be noted that Taylor does not warrant the refrigerant used in its equipment. For example, if the refrigerant is lost during the course of ordinary service to this machine, Taylor has no obligation to either supply or provide its replacement either at billable or unbillable terms. Taylor does have the obligation to recommend a suitable replacement if the original refrigerant is banned, obsolete, or no longer available during the five-year warranty of the compressor.

Taylor will continue to monitor the industry and test new alternates as they are being developed. Should a new alternate prove, through our testing, that it would be accepted as a drop-in replacement, then the above disclaimer would become null and void. To find out the current status of an alternate refrigerant as it relates to your compressor warranty, call the local Taylor distributor or the Taylor factory. Be prepared to provide the model/serial number of the unit in question.

2

We, at Taylor Company, are concerned about the safety of operators when they come in contact with the freezer and its parts. Taylor has gone to extreme efforts to design and manufacture built-in safety features to protect both you and the service technician. As an example, warning labels have been attached to the freezer to further point out safety precautions to the operator.

To Operate Safely



IMPORTANT! Failure to adhere to the following safety precautions may result in severe personal injury. Failure to comply with these warnings may damage the machine and its components. Component damage will result in part replacement expense and service repair expense test.



NOTICE! DO NOT operate the freezer without reading the Operator's Manual. Failure to follow this instruction may result in equipment damage, poor freezer performance, health hazards, or personal injury.



IMPORTANT! This appliance is to be used only by trained personnel. It is not intended for use, cleaning, or maintenance by children or people with reduced physical, sensory, or mental capabilities, or lack of experience and knowledge, unless given supervision or instruction concerning the use of the appliance by a person responsible for their safety.



IMPORTANT! This unit is provided with an equipotential grounding lug that is to be properly attached to either the rear of the frame or the underside of the base pan near the entry hole for incoming power, by the authorized installer. The installation location is marked by the equipotential bonding symbol (5021 of

IEC 604171) on both the removable panel and the equipment's frame, as well as on the diagram.



WARNING! Avoid injury.

- **DO NOT** operate the freezer unless it is properly grounded.
- **DO NOT** operate freezer with larger fuses than specified on the data label.
- All repairs must be performed by an authorized Taylor service technician.
- The main power supplies to machine must be disconnected prior to performing repairs.
- **For Cord-Connected Units:** Only authorized Taylor service technicians or licensed electricians may install a plug or replacement cord on the unit.
- Stationary appliances which are not equipped with a power cord and a plug or another device to disconnect the appliance from the power source must have an all-pole disconnecting device with a contact gap of at least 0.125 in. (3 mm) installed in the external installation.
- Appliances that are permanently connected to fixed wiring and for which leakage currents may exceed 10 mA, particularly when disconnected or not used for long periods, or during initial installation, shall have protective devices to protect against the leakage of current, such as a GFI, installed by the authorized personnel to the local codes.
- Supply cords used with this unit shall be oil-resistant, sheathed flexible cable not lighter than ordinary polychloroprene or other equivalent synthetic elastomer-sheathed cord (code designation 60245 IEC 57) installed with the proper cord anchorage to relieve conductors from strain, including twisting, at the terminals and protect the insulation of the conductors from abrasion.
- If the supply cord is damaged, it must be replaced by the manufacturer, service agent, or a similarly qualified person, in order to avoid a hazard.

SAFETY

- Secure the supply cord ground lead to the machine in a location where if the cord is pulled, the main power leads will become taut before the ground lead can break loose.

Failure to follow these instructions may result in electrocution. Contact your local authorized Taylor distributor for service.



WARNING! DO NOT install the units in an area where a water jet could be used. Failure to follow this instruction may result in serious electrical shock.



WARNING! Avoid injury.

- **DO NOT** allow untrained personnel to operate this machine.
- **DO NOT** put objects or fingers in door spout.
- **DO NOT** operate the freezer unless all service panels and access doors are restrained with screws.
- **DO NOT** remove the freezer door or beater assembly unless the control switches are in the OFF position.

Failure to follow these instructions may result in severe personal injury to fingers or hands from hazardous moving parts.



WARNING! This unit has many sharp edges that can cause severe injuries.



IMPORTANT! Access to the service area of the unit is restricted to persons having knowledge and practical experience with the appliance, in particular as far as safety and hygiene are concerned.



CAUTION! This unit must be installed on a level surface to avoid the hazard of tipping. Extreme care should be taken in moving this equipment for any reason. Two or more persons are required to safely move this

unit. Failure to comply may result in personal injury or equipment damage.



NOTICE! Cleaning and sanitizing schedules are governed by your federal, state, or local regulatory agencies and must be followed accordingly. Please see the cleaning section of this manual for the proper procedure to clean this unit.



CAUTION! This machine is designed to maintain product temperature under 41°F (5°C). Any product being added to this machine must be below 41°F (5°C). Failure to follow this instruction may result in health hazards and poor freezer performance.

Do not obstruct air intake and discharge openings:

A minimum of 3 in. (76 mm) air space is required on all sides. Install the deflector provided to prevent recirculation of warm air. Failure to follow this instruction may cause poor freezer performance and damage to the machine.

For Indoor Use Only: This unit is designed to operate indoors, under normal ambient temperatures of 70°F to 75°F (21°C to 24°C). The freezer has successfully performed in high ambient temperatures of 104°F (40°C) at reduced capacities.

Do not run the machine without product. Failure to follow this instruction can result in damage to the machine.

Noise Level: Airborne noise emission does not exceed 78 dB(A) when measured at a distance of 1.0 meter from the surface of the machine and at a height of 1.6 meters from the floor.

Model C713

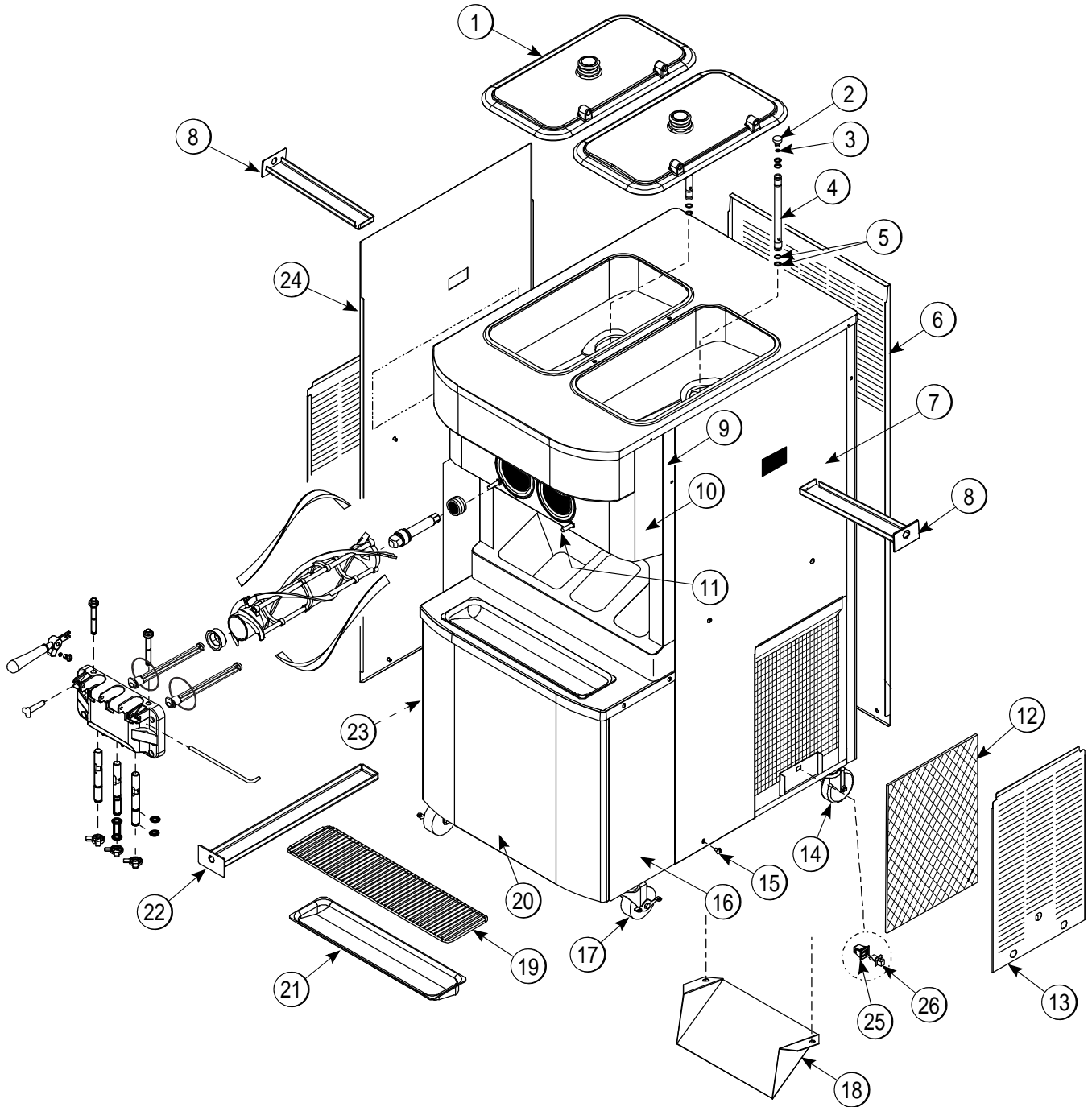

Figure 4-1

OPERATOR PARTS IDENTIFICATION

C713 Exploded View Parts Identification

Item	Description	Part No.
1	KIT A.-Cover-Hopper	X67061-SP
2	Orifice	022465-100
3	O-Ring-3/8 OD X .070 W	016137
4	Tube A.-Feed-SS 5/32 Hole	X29429-2
5	O-Ring-.643 OD X .077 W	018572
6	Panel-Rear	059917
7	Panel-Side Right	059907
8	Pan-Drip 12.5	059736
9	Panel A.-Front	X63879
10	Panel A.-Front	X59836
11	Stud-Nose Cone	055987
12	Filter-Air-Poly-Flo	052779-11
13	Panel A.-Filter-Louvered	X59928
14	Caster-4 in. SWV 3/4-10 Stem	044106

Item	Description	Part No.
15	Screw-1/4-20 X 3/8 RHM-SS	011694
16	Panel-Corner-Front Right	063087
17	Caster-4" SWV 3/4-10 Stem w/Brake	046437
18	Deflector-Blower	047912
19	Shield-Splash-Wire-19-3/4 L	033813
20	Panel A.-Front Lower	X59854-SER
21	Tray-Drip-19-5/8 L X 4-7/8	033812
22	Pan-Drip 19-1/2 Long	035034
23	Panel-Corner-Front Left	063088
24	Panel-Side Left	059906
25	Fastener-Door Latch	030787
26	Fastener-Door Strike	030788

4

Model C713 Door and Beater Assembly

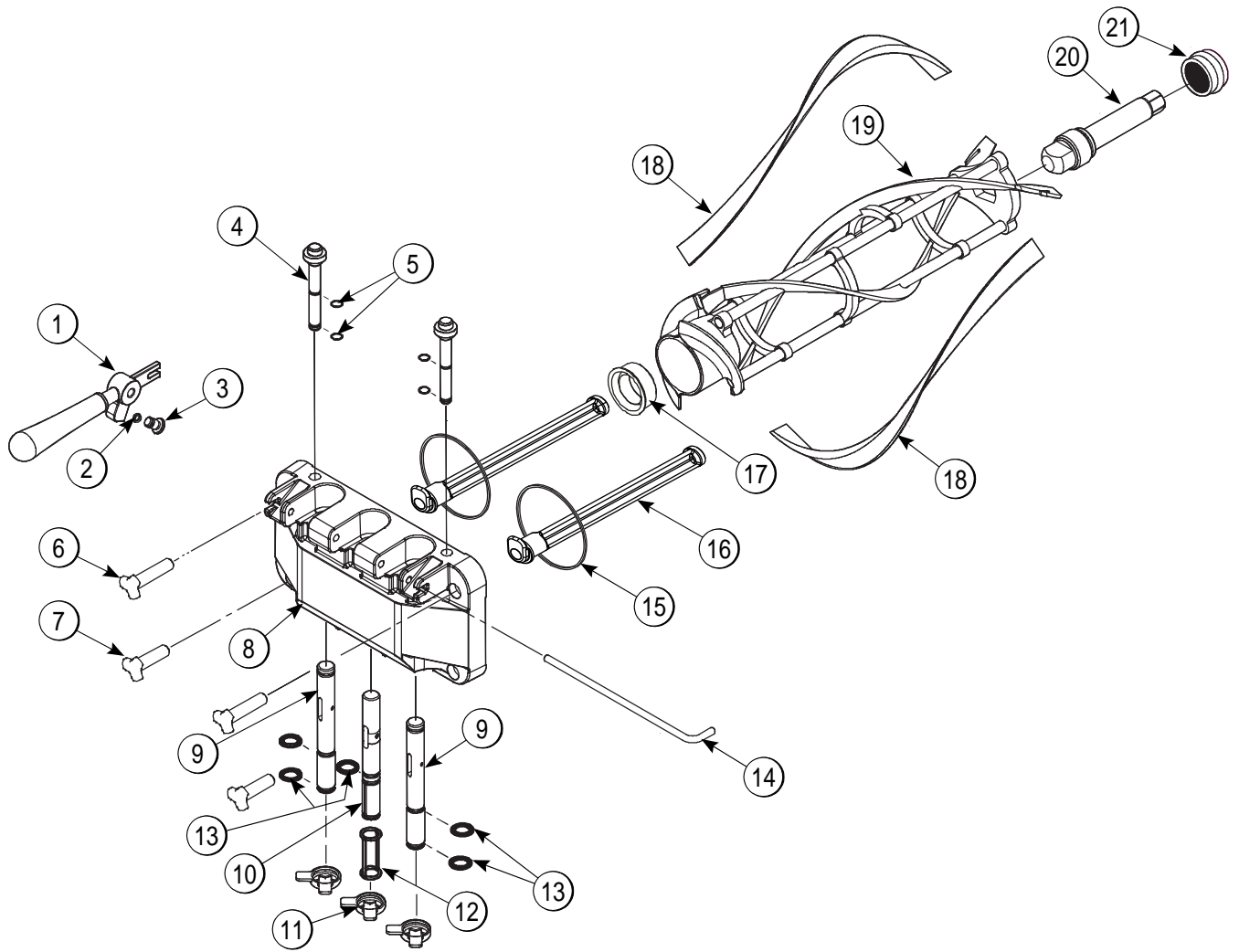

4

Figure 4-2

Item	Description	Part No.
1	Handle A.-Draw-Welded	X56421-1
2	O-Ring-1/4 OD (25 to Bag)	015872
3	Screw-Adjustment-5/16-24	056332
4	Plug-Prime Twin	059936
5	O-Ring-1/2 OD (50 to Bag)	024278
6	Nut-Stud-Black 3.250 Long	058765
7	Nut-Stud-Black 2.563 Long	058764
8	Door A.-3SPT*	X88684
9	Valve A.-Draw	X69615
10	Valve A.-Draw Center	X62218
11	Cap-Design 1.010" ID - 6 PT	014218

Item	Description	Part No.
12	Seal-Draw Valve	034698
13	O-Ring-7/8 OD X .0103W-SIL	083693
14	Pin-Handle-Twin	059894
15	Gasket-Door HT 4 in.-Double	048926
16	Baffle-Threadless Molded	087708
17	Bearing-Front	088811
18	Blade-Scraper-Plastic	035174
19	Beater A.-3.4 qt-Helicore	X31761
20	Shaft-Beater	032564
21	Seal-Drive Shaft	032560

Accessories

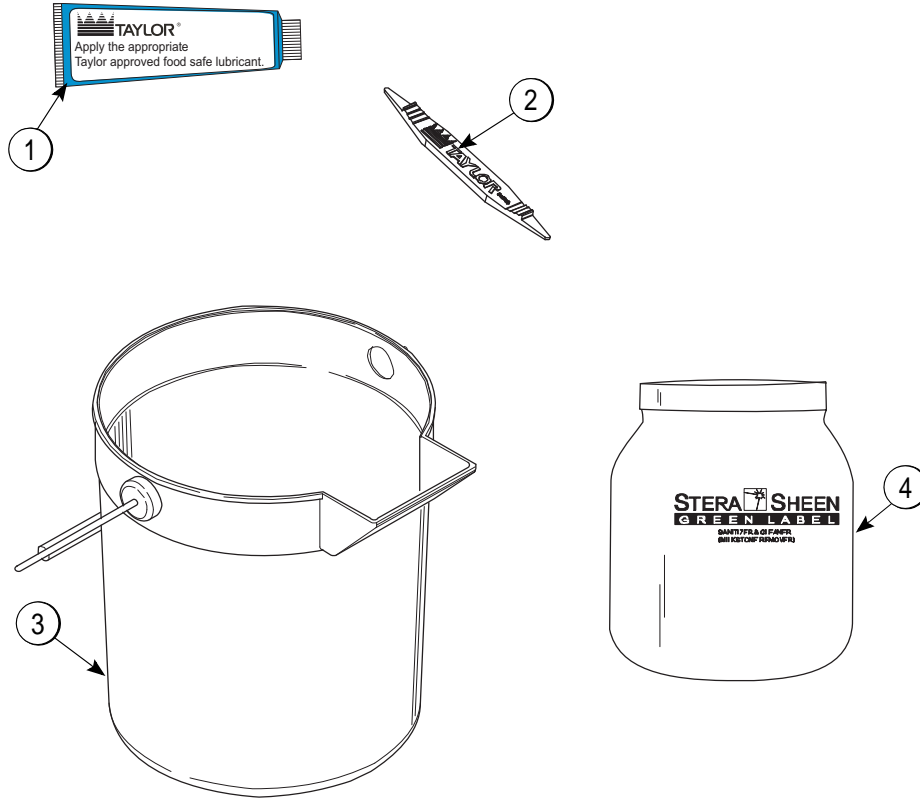

Figure 4-3

Item	Description	Part No.
1	Lubricant-Taylor	047518
2	Tool-O-Ring Removal	048260-WHT
3	Pail-10 qt	013163

Item	Description	Part No.
4	Sanitizer-Stera Sheen®	See Note.
*	Kit A.-Tune-Up	X49463-80

* Not Shown

Note: A sample container of sanitizer is sent with the unit. For reorders, order Stera Sheen® part no. 055492 (100 2 oz. packs) or Kay-5® part no. 041082 (200 packs).

Brushes

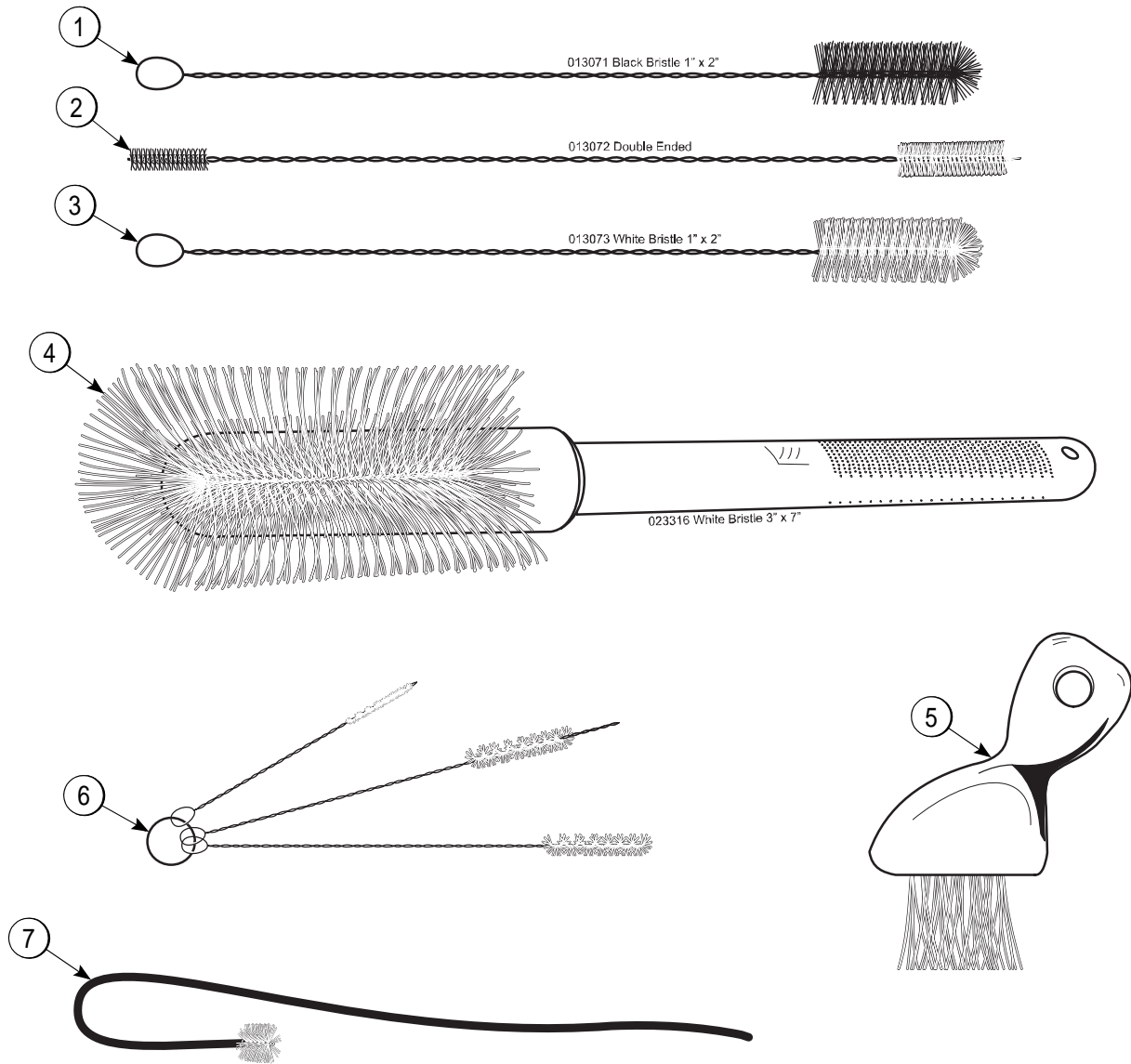

4

Figure 4-4

Item	Description	Part No.
1	Black Bristle Brush	013071
2	Double End Brush	013072
3	White Bristle Brush (1" x 2")	013073
4	White Bristle Brush (3" x 7")	023316

Item	Description	Part No.
5	Brush-End-Door Spout SS	039719
6	Brush-Set LVB	050103
7	Brush-Pump Spout	054068

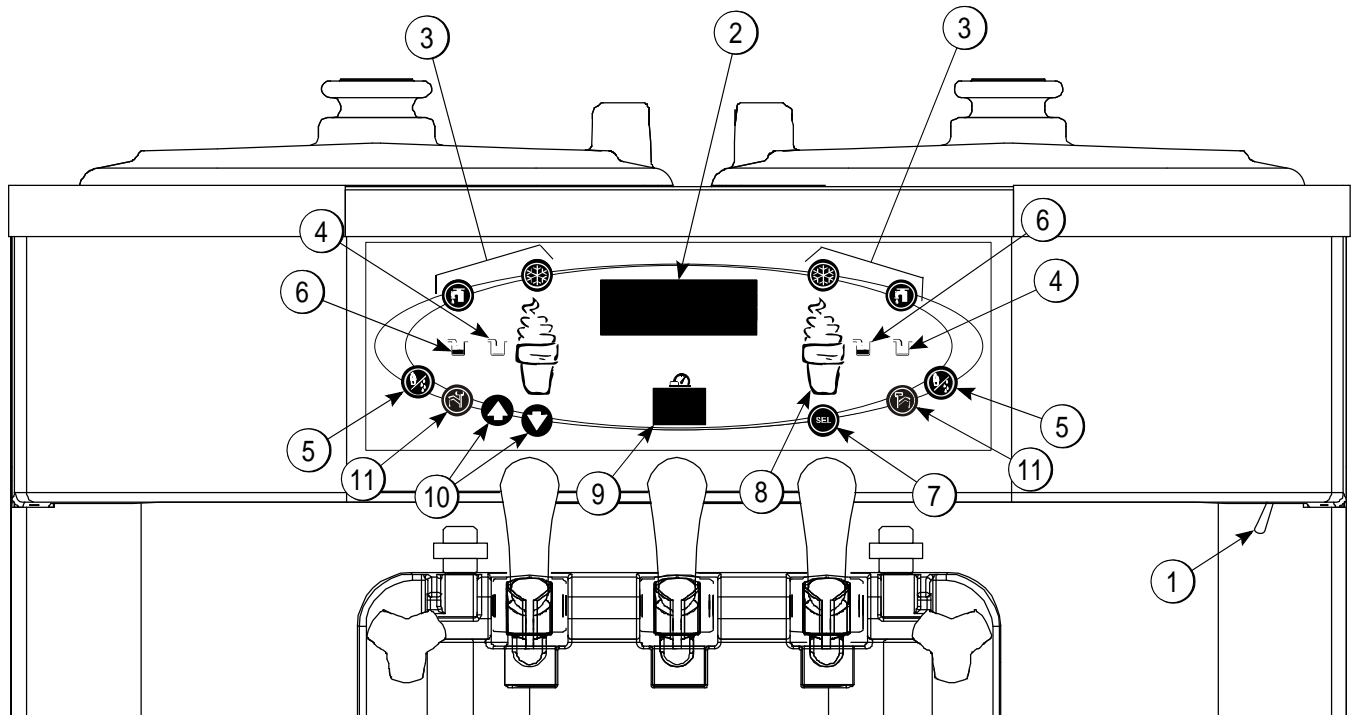

Figure 5-1

5













Item	Description
1	Power Switch
2	Liquid Crystal Display
3	Keypads
4	Mix Out Indicator
5	Standby Key
6	Mix Low Indicator

Item	Description
7	Select Key
8	Service Menu Key
9	Brush Clean Counter
10	Arrow Keys
11	Topping Heater Keys

Symbol Definitions

To better communicate in the international arena, symbols have replaced words on many of our operator switches, function, and fault indicators. Your Taylor equipment is designed with these international symbols.

The following chart identifies the symbol definitions.

	= SELECT
	= ON
	= OFF
	= UP ARROW
	= DOWN ARROW
	= AUTO
	= WASH
	= MIX LOW
	= MIX OUT
	= MENU DISPLAY
	= STANDBY
	= TOPPING HEATER-LEFT
	= TOPPING HEATER-RIGHT

5

Power Switch

When placed in the ON position, the power switch allows control panel operation.

Fluorescent Display

The fluorescent display is located on the front control panel. During normal operation the display is blank. The display is used to show menu options and notifies the operator if a fault is detected. On international models, the display indicates the temperature of the mix in the hopper.

Indicator Lights

MIX LOW—When the MIX LOW symbol  is illuminated, the mix hopper has a low supply of mix and should be refilled as soon as possible.

MIX OUT—When the MIX OUT  symbol is illuminated, the mix hopper has been almost completely exhausted and has an insufficient supply of mix to operate the freezer. At this time, the Auto mode is locked out and the freezer is placed in the Standby mode. To initiate the refrigeration system, add mix to the mix hopper and

touch the AUTO symbol . The freezer automatically begins operation.

Standby Symbol

During long “no sale” periods, the unit can be placed into the Standby mode. This maintains product temperatures below 40°F (4.4°C) in both the hopper and the freezing cylinder, and helps prevent overbeating and product breakdown.

Using clean, sanitized hands, remove the air orifice. Lubricate the O-rings located on the end of the feed tube without the hole. Place that end of the tube into the mix inlet hole. When STANDBY is selected, the STANDBY

symbol  illuminates, indicating the Standby feature has been activated.

Note: Make sure the level of mix in the hopper is below the mix inlet hole in the feed tube. Failure to follow this instruction may result in lower product quality when normal operation is resumed.

To resume normal operation, press the AUTO symbol.

❄️. When the unit cycles off, the product in the freezing cylinder will be at serving viscosity. At this time, turn the feed over. Place the end of the tube with the hole into the mix inlet hole. Install the air orifice.

Wash Symbol

The WASH symbol 🧼 will illuminate when it is touched. This indicates beater motor operation. The Standby or Auto modes must be canceled first to activate the Wash mode.

Auto Symbol

The AUTO symbol ❄️ will illuminate when it is touched. This indicates that the refrigeration system has been activated. In the Auto mode, the Wash or Standby functions are automatically canceled.

Note: An indicating light and an audible tone will sound whenever a mode of operation has been selected. To cancel any function, touch the key again. The light and the mode of operation will shut off.

Reset Mechanism

The Reset buttons are located in the back panel of the machine. The Reset mechanism protects the beater motor from an overload condition. Should an overload occur, the reset mechanism will trip. To properly reset the freezer, place the power switch in the OFF position. Press the Reset button firmly. Turn the power switch to the ON position. Touch the WASH symbol 🧼 and observe the freezer's performance.



DANGER! DO NOT use metal objects to press the Reset button. Failure to comply may result in severe personal injury or death.

If the beater motor is turning properly, touch the WASH symbol 🧼 to cancel the cycle. Touch the AUTO symbol ❄️ to resume normal operation. If the freezer shuts down again, contact your authorized service technician.

Feed Tube

The feed tube serves two purposes. One end of the tube has a hole and the other end does not. The air orifice maintains overrun and allows enough mix to enter the freezing cylinder after a draw.

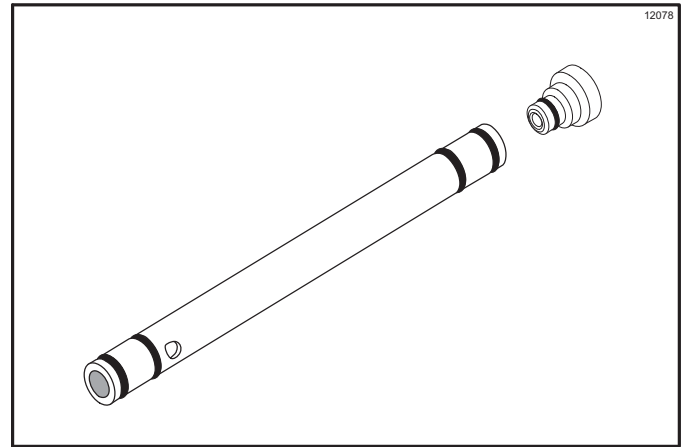

Figure 5-2

Normal Operation

During normal operation, the end of the feed tube with the hole is placed into the mix inlet hole. Every time the draw handle is raised, new mix and air from the hopper flow into the freezing cylinder. This keeps the freezing cylinder properly loaded and maintains overrun.

Long “No Sale” Periods

During long “no sale” periods, the unit can be placed into the Standby mode. This mode maintains product temperatures below 40°F (4.4°C) in both the hopper and the freezing cylinder, and helps prevent overbeating and product breakdown. To activate Standby, enter the access code for the Manager’s Menu (see “Manager’s Menu” on page 5-5). Remove the air orifice. Lubricate the O-rings located on the end of the feed tube without the hole. Place that end of the tube into the mix inlet hole.

Note: Make sure the level of mix in the hopper is below the mix inlet hole in the feed tube. Failure to follow this instruction may result in lower product quality when normal operation is resumed.

To resume normal operation, press the Auto symbol ❄️. When the unit cycles off, the product in the freezing cylinder will be at serving viscosity. At this time, turn the feed over. Place the end of the tube with the hole into the mix inlet hole. Install the air orifice. The air orifice is used to meter a certain amount of air into the freezing cylinder.

Adjustable Draw Handle

This unit features an adjustable draw handle to provide the best portion control, giving a better, consistent quality to your product and controlling costs. The draw handle should be adjusted to provide a flow rate of 5 oz. to 7-1/2 oz. (142 g. to 213 g.) of product by weight per 10 seconds. To **increase** the flow rate, tighten the screw. To **decrease** the flow rate, loosen the screw.

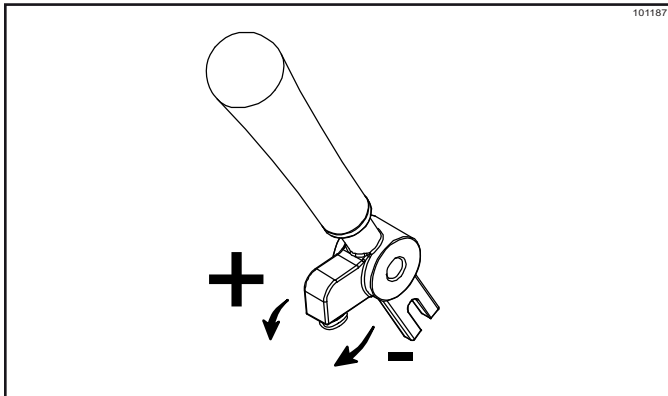

Figure 5-3

5 Operating Screen Descriptions

The fluorescent display located in the center of the control panel is normally blank during the daily operation of the machine. The display is activated when the SEL symbol or the Manager's Menu is selected. The display screen will also alert the operator of specific faults detected by the control.

Power Up

When the machine is powered, the control system will initialize to perform a system check. The screen will display INITIALIZING. There will be four types of data the system will check: LANGUAGE, SYSTEM DATA, CONFIG DATA, and LOCKOUT DATA.

During the INITIALIZING... LANGUAGE screen, the alarm will be on. If the system detects corrupt data during INITIALIZING, the following display will alert the operator that the control settings may have been changed.

**NVRAM FAULT
RESET TO DEFAULTS
PRESS SEL KEY**

See "NVRAM FAULT" for instructions if the above message appears on the screen.

Once the system has initialized, the number of days remaining before the next required brush cleaning is indicated on the control panel, and the SAFETY TIMEOUT screen is displayed with the alarm turned on.

**SAFETY TIMEOUT
ANY KEY ABORTS**

The SAFETY TIMEOUT screen appears with the alarm on, for 60 seconds or until any control symbol is selected. After the safety timeout has been completed and the power switch is OFF, the following screen is displayed.

**POWER SWITCH OFF
- - - - -
UNIT CLEANED**

Power Switch ON



When the power switch is placed in the ON position, the control panel touch keys become operative. The fluorescent display either is blank or indicates that the unit has been cleaned.

UNIT CLEANED

Brush Clean Counter

The brush clean counter displays the number of hours since the freezer was last brush cleaned. After hour 99, the number changes to a letter and a number (example: A0, A1. . B0, B1, etc.).

Manager's Menu

The Manager's Menu is used to enter the operator function displays. To access the menu, touch the center of the CONE symbol  on the control panel. The arrow symbols, the SEL symbol, and the CONE symbol  are lit when the ACCESS CODE screen is displayed.

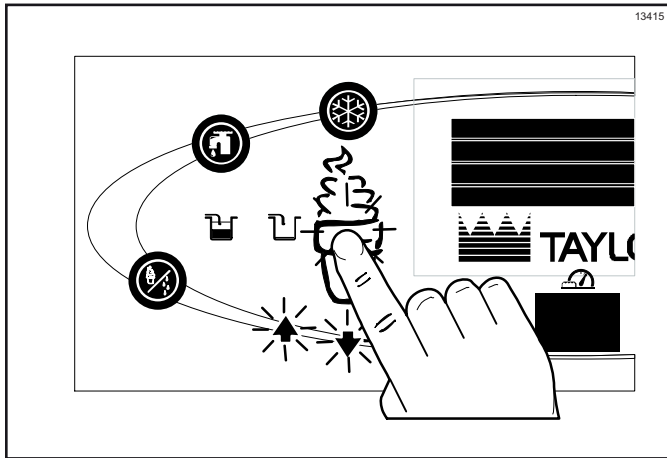

Figure 5-4

In the Manager's Menu program, the arrow symbols and the SEL symbol will function as menu keys.

The up arrow increases the value above the cursor and is used to scroll upward in text displays.

The down arrow decreases the value above the cursor and is used to scroll downward in text displays.

SEL advances the cursor position to the right and is used to select menu options.

Note: *The machine will continue operation in the mode it was in when the menu was selected. However, the control keys will not be lit and will not function when the Manager's Menu is displayed.*

Entering Access Code

With the ACCESS CODE screen on the display, use the SEL symbol to set the first code number in the cursor position. When the correct number is selected, touch the SEL symbol to move the cursor to the next number position.

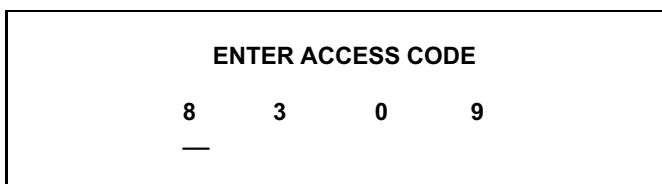



Figure 5-5

Continue to enter the proper access code numbers (8309) until all four numbers are displayed, then touch the SEL symbol. The Manager's Menu list appears on the screen if the correct access code is entered.

If an incorrect number is entered for the access code, the display will exit the Manager's Menu when the SEL symbol is selected.

Menu Options

Touch the arrow symbols to move up or down through the menu. Select a menu option by touching the SEL symbol. Exit the menu program by selecting EXIT FROM MENU or touch the CONE symbol .

The following menu options are listed in the Manager's Menu.

- EXIT FROM MENU
- SERVINGS COUNTER
- SET CLOCK
- AUTO START TIME
- STANDBY MODE
- MIX LEVEL AUDIBLE
- FAULT DESCRIPTION
- FAULT HISTORY
- LOCKOUT HISTORY
- SYSTEM INFORMATION
- CURRENT CONDITIONS
- NET SERVICE PIN

Exit from Menu

Selecting EXIT FROM MENU will exit the Manager's Menu and return the control panel keys to normal operation.

Servings Counter

The SERVINGS COUNTER screen is used to check or reset the number of servings dispensed from the unit. The servings counter will automatically reset to zero when the unit is brush cleaned.

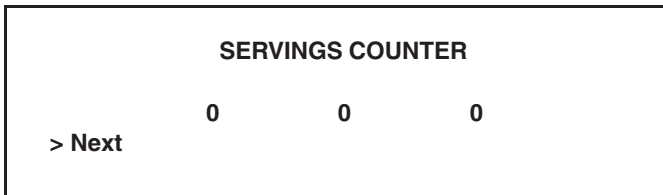

Reset the servings counter by pressing the SEL key which advances to the next screen. Touch the up arrow key to move the arrow (>) to Yes and then touch the SEL key. The servings counter will reset to zero and exit to the Manager's Menu.

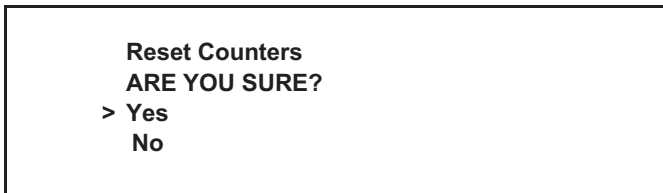

Set Clock

The SET CLOCK screen allows the manager or service technician to adjust the real time clock if the unit is in the brush cleaned state. The following message appears if SET CLOCK is selected when the unit is not in a brush clean state.

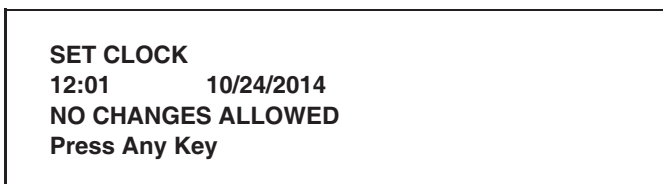

If the unit is in the brush cleaned state, pressing the SEL key would display the following screen.

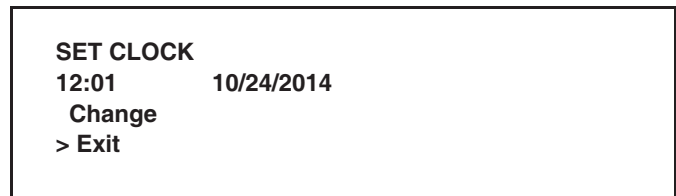

To make any changes, press the up arrow key to move to Change and press the SEL key. Pressing the SEL key will scroll the cursor to the right one digit for each key press. Pressing the up or down arrow keys increases or decreases the selected digits.

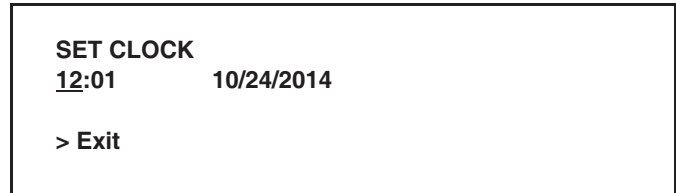

After all changes have been made and the year has been set, pressing the SEL key will display the first DAYLIGHT SAVING TIME (DST) screen.



Pressing the up or down arrow keys will move the arrow to Enable or Disable. Pressing the SEL key next to Disable will disable Daylight Saving Time and return to the Manager's Menu. Pressing the SEL key next to Enable selects that option and displays the month and Sunday screen.

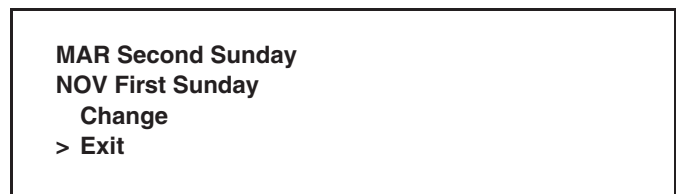

If the correct Sunday for the time change is not displayed, then Change should be selected. Pressing the SEL key with the arrow next to Change displays the DST Start Month screen. Press the up or down arrow keys to move the arrow to the appropriate month for the start of DST.

DST START MONTH
 > MAR
 APR
 MAY

Pressing the SEL key with the arrow next to the appropriate month selects the Start Month and then displays the DST Start Week screen. Pressing the up or down arrow keys will move the arrow to the appropriate week for the start of DST.

DST START WEEK
 > Second Sunday
 Third Sunday
 Fourth Sunday

Pressing the SEL key next to the appropriate week will display the DST End Month screen. Press the up or down arrow keys to move the arrow to the appropriate month for the end of DST.

DST END MONTH
 > NOV
 DEC

Pressing the SEL key next to the appropriate month will display the DST End Week screen. Press the up or down arrow keys to move the arrow to the appropriate week for the end of DST.

DST END WEEK
 > First Sunday
 Second Sunday
 Third Sunday

Pressing the SEL key with the arrow next to the appropriate week will select that setting and return to the Menu screen.

Auto Start Time

The AUTO START TIME screen allows the manager to set the time of day when the unit automatically enters the Auto mode from the Standby mode. The unit must be in the Standby mode without a freezer lock condition in order to automatically start at the programmable time. The auto start time can also be disabled and require

starting the Auto mode manually.

AUTO START TIME
 DISABLED
 Enable
 > Disable

Enable the auto start time by pressing the up arrow key to move the arrow up to Enable. Touch the SEL key to advance to the next screen.

AUTO START TIME
 00:00
 Change
 > Exit

Program the auto start time by pressing the up arrow key to move the arrow to Change. Touch the SEL key to advance to the next screen.

AUTO START TIME
 00:00

Use the up and down arrow keys to program the auto start time by increasing or decreasing the hour setting above the cursor. Touch the SEL key to advance the cursor and program the minutes setting. Touch the SEL key to return to the previous screen with the new time setting displayed. Touch the SEL key to exit the screen and return to the Manager's Menu.

Standby Mode

The STANDBY MODE screen is used to manually place the unit in the Standby mode during long, no draw periods. Press the Up key to place the arrow next to the appropriate side. Press the SEL key to place that side of the unit into Standby and return to the main menu screen.

STANDBY MODE
 LEFT
 RIGHT
 > EXIT

Mix Level Audible

The MIX LEVEL AUDIBLE screen, when enabled, will alert the operator with an audible tone when there is a Mix Low or a Mix Out condition. The following screen is displayed upon selecting this option.

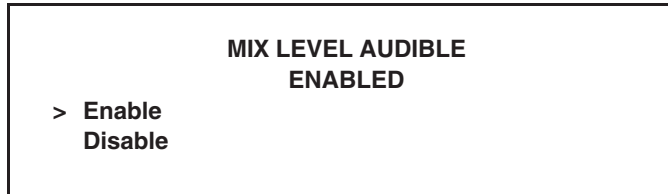

Disable the audible tone feature by pressing the down arrow key to move the arrow to Disable. Touch the SEL key to save the new setting and return to the Manager's Menu. The control panel icons for Mix Low and Mix Out will illuminate as the mix level drops in the hopper, but the audible tone will be disabled.

Fault Description

The fluorescent display is located on the front control panel. During normal operation, the display is blank. The display is used to show menu options and notifies the operator if a fault is detected. On international models, the display will indicate the temperature of the mix in the hopper. If a fault does occur, it will appear on the display.

NO FAULT FOUND—There was no fault found in the freezer. Nothing will appear on the screen after this variable message appears.

BEATER OVERLOAD—Place the power switch in the OFF position. Press the beater Reset button firmly. Place the power switch in the ON position and restart in Auto mode.

HPCO COMPRESSOR—Place the power switch in the OFF position. Wait 5 minutes for the unit to cool. Place the power switch in the ON position and restart in Auto mode.

PRODUCT DOOR OFF—The door must be installed on the unit.

HOPPER THERMISTOR FAIL*—Place the power switch in the OFF position. Replace the hopper thermistor probe.

BARREL THERMISTOR FAIL*—Place the power switch in the OFF position. Replace the barrel thermistor probe.

**Note: Three codes have been set up to assist in diagnosing bad thermistor probes. If a probe has shorted (resistance less than 1 ohm), SHRT will be displayed on the screen for its respective unit location. If the probe is open (resistance above 1 megohm), OPEN will be displayed. If the actual probe environment exceeds 200°F (93°C), the respective screen display location will read OVER, indicating the temperature is “out of range.”*

Fault History

The FAULT HISTORY screen will display up to 100 faults that have occurred. Page numbers are displayed in the upper right corner. Page one contains the most recent fault. Pressing the Up arrow key cycles through the Fault History pages from most recent to oldest. Pressing the Down arrow key cycles from the oldest to the most recent. The date and time of the event are displayed on the second line. The third line displays the reason for the fault.

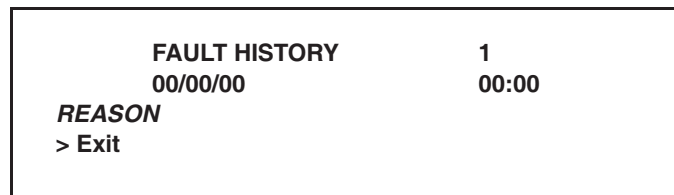

Faults Occurring While in Auto or Standby Mode

(L/R) HPR>41F (5C) AFTER 4 HR—The mix temperature in the hopper was above 41°F (5°C) for more than four hours.

(L/R) BRL>41F (5C) AFTER 4 HR—The mix temperature in the freezing cylinder was above 41°F (5°C) for more than four hours.

(L/R) HPR>41F (5C) AFTER PF—The mix temperature in the hopper was above 41°F (5°C) for more than four hours following a power failure.

(L/R) HPR>45F (7C) AFTER 1 HR—The mix temperature in the left or right hopper was above 45°F (7°C) for more than one hour.

(L/R) BRL>45F (7C) AFTER 1 HR—The mix temperature in the left or right barrel was above 45°F (7°C) for more than one hour.

(L/R) BRL>41F (5C) AFTER PF—The mix temperature in the freezing cylinder was above 41°F (5°C) for more than four hours following a power failure.

(L/R) HPR>59F (15C)—The mix temperature in the hopper exceeded 59°F (15°C).

(L/R) BRL>59F (15C)—The mix temperature in the hopper exceeded 59°F (15°C).

(L/R) COMP ON TOO LONG—The compressor run time exceeded the 11 minute timer.

Note: Refer to your local health codes regarding temperature recommendations for procedures to follow if these fault screens appear.

Lockout History

The LOCKOUT HISTORY screen displays a history of the last 100 soft locks, hard locks, brush clean dates, or aborted heat cycles. Page numbers are indicated in the upper right corner of the screen. Page 1 always contains the most recent failure.

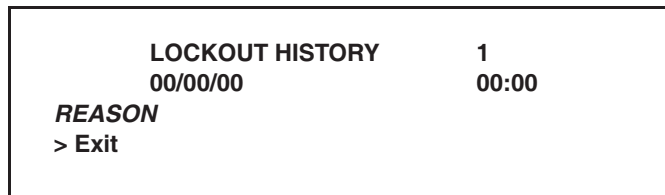

The second line of the screen displays the date and time a failure occurs. The third line indicates the reason for a failure or if a successful brush cleaning has occurred. Some failures occur with multiple reasons. When this occurs, a record will be generated for each reason.

Use the up and down arrow keys to advance forward or move backward to view each screen.

System Information

System information appears on three separate screens. The first screen contains the control and software version installed in the unit.



Touch the SEL key to advance to the next system information screen, containing the software language version.

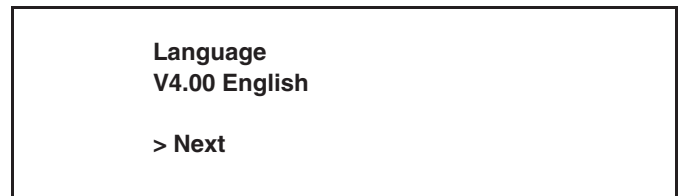

Touch the SEL key to advance to the third system information screen, containing the model bill of material and unit serial number.

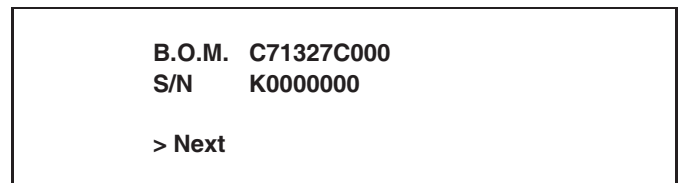

Pressing the SEL key again will return to the main menu.

Current Conditions

This screen provides the viscosity readings for the product when the unit is running, and the hopper and the freezing cylinder temperatures for the unit.

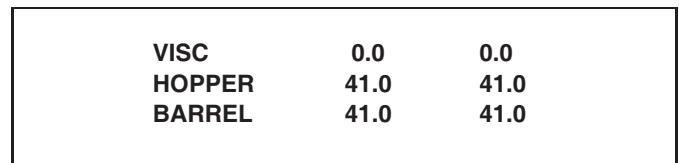

Press the SEL or Menu key to return to the main menu.

Net Service Pin

The NET SERVICE PIN screen allows the manager or service technician to initialize a network connection for networking kitchens.

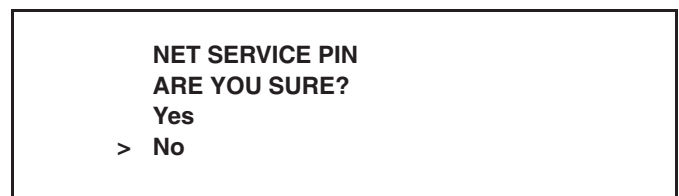

Pressing the up or down arrow keys moves the arrow to Yes or No. Pressing the SEL key with the arrow next to No will return to the MAIN MENU screen. Pressing the SEL key with the arrow next to Yes will connect to the network if a gateway card is connected. If Yes is selected, the unit will appear to hang until the memory is cleared and the defaults are loaded. The display may show the message COMMUNICATIONS FAILURE during this time.

The Model C713 machine stores mix in the hoppers. It has two 3.4 qt. (3.2 L) capacity freezing cylinders with a three-spout door. Mix flows by gravity through a feed tube down into the freezing cylinders.

We begin our instructions at the point where we enter the store in the morning and find the parts disassembled and laid out to air dry from the previous night's cleaning.

These opening procedures show you how to assemble these parts into the freezer, sanitize them, and prime the freezer with fresh mix in preparation to serve your first portion.

If you are disassembling the machine for the first time or need information to get to this starting point in our instructions, turn to "Disassembly" on page 6-7 and start there.

Freezing Cylinder Assembly

Note: When lubricating parts, use an approved food grade lubricant (example: Taylor Lube).



WARNING! Make sure the power switch is in the OFF position! Failure to follow this instruction may result in severe personal injury to fingers or hands from hazardous moving parts.

1. Before installing the beater drive shaft, lubricate the groove on the beater drive shaft.
2. Slide the beater drive shaft boot seal over the small end of the beater drive shaft and engage into the groove on the shaft.
3. Heavily lubricate the inside portion of the boot seal and also lubricate the flat end of the boot seal that comes in contact with the rear shell bearing.
4. Apply an even coat of lubricant to the shaft. **Do not** lubricate the hex end.

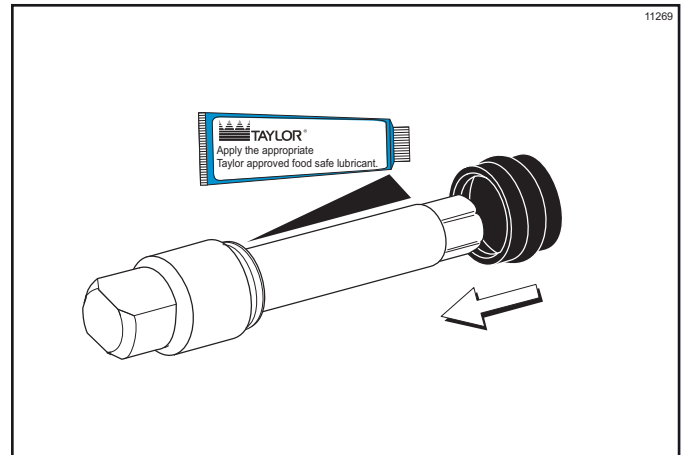

Figure 6-1

Note: To ensure the mix does not leak out of the back of the freezing cylinder, the middle section of the boot seal should be convex or extend out from the seal. If the middle section of the boot seal is concave or extending into the middle of the seal, turn the seal inside out.

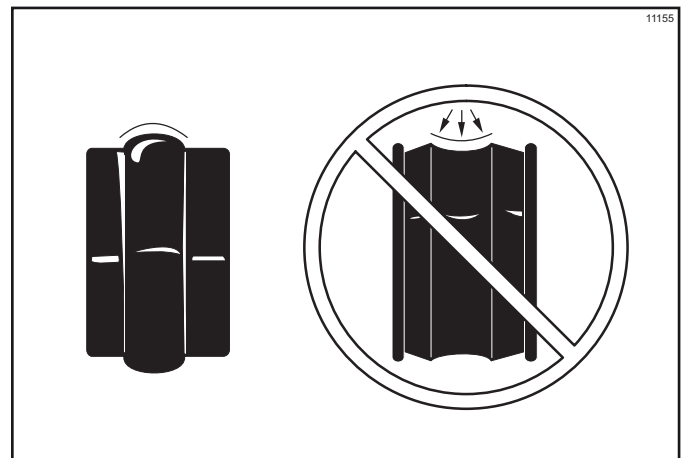

Figure 6-2

5. Insert the beater drive shaft through the rear shell bearing in the freezing cylinder and engage the hex end firmly into the drive coupling.

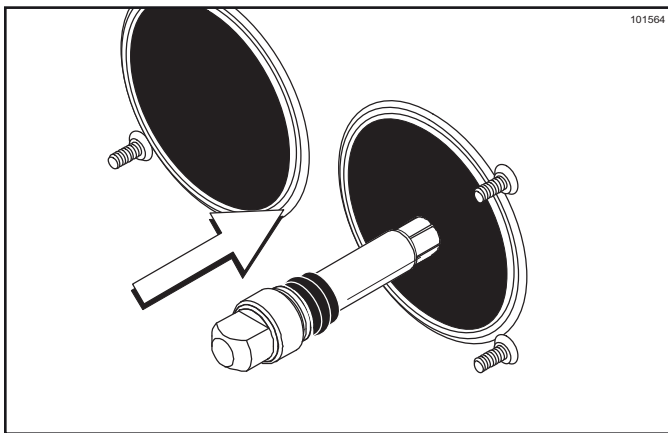

Figure 6-3



WARNING! This unit has many sharp edges that can cause severe injuries. Use extreme caution when handling the beater assembly. Failure to follow instructions may cause injury.

6. Before installing the beater assembly, check the scraper blades. If they are in good condition, take one of the scraper blades and slip it under the hook at the front of the beater. Wrap the blade around the beater, following the helix and pushing the blade down onto the helix as you wrap. At the back end of the beater, slip the blade under the hook.

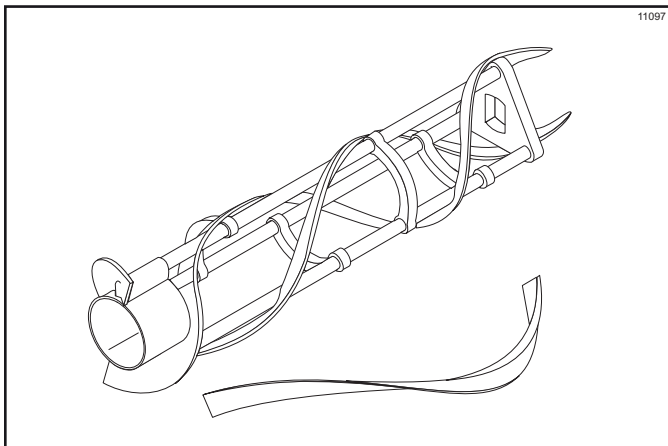

Figure 6-4

Repeat this step for the second scraper blade.

7. Holding the beater securely, slide the beater into the freezing cylinder about one-third of the way in. Looking into the freezing cylinder, align the hole at the rear of the beater with the flats on the end of the drive shaft.

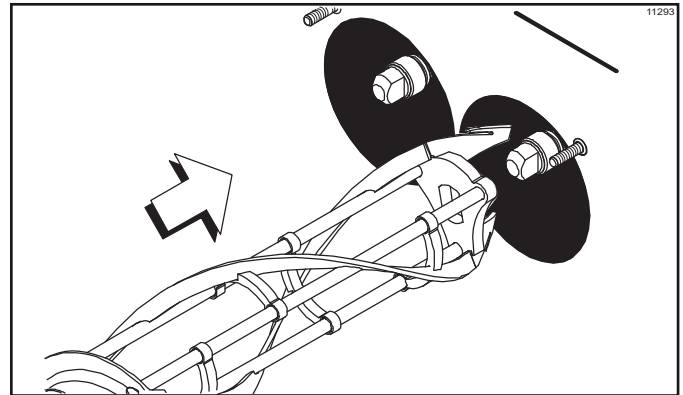

Figure 6-5

8. Slide the beater the remainder of the way into the freezing cylinder and over the end of the drive shaft. The beater should fit snugly but not so tightly that the beater cannot be turned slightly to engage the drive shaft.
Make sure the beater assembly is in position over the drive shaft. Turn the beater slightly to make sure the beater is properly seated. When in position, the beater does not protrude beyond the front of the freezing cylinder.
9. Repeat steps 1 through 8 for the other side of the machine.
10. To assemble the freezer door, place the door gaskets into the grooves on the back of the freezer door. Slide the front bearings over the baffle rods. The flanged edges should be against the door. **Do not** lubricate the gaskets or bearings.
11. Slide the two O-rings into the grooves on each prime plug. Apply an even coat of Taylor Lube to the O-rings and shafts.

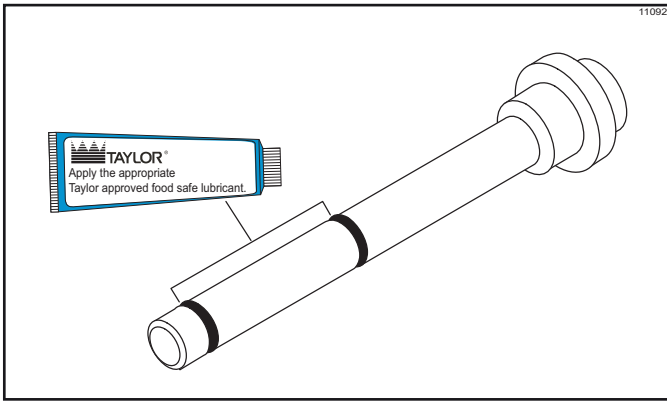

Figure 6-6

12. Insert the prime plugs into the holes in the top of the freezer door and push down.

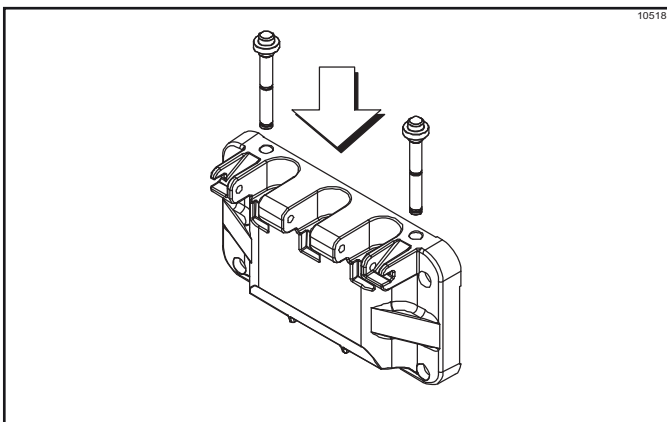

Figure 6-7

13. To install the freezer door, install the baffles by raising the round ends while engaging the lugs into the door pockets. Lower the round ends to secure to the door. Insert the baffles through the beaters in the freezing cylinders.

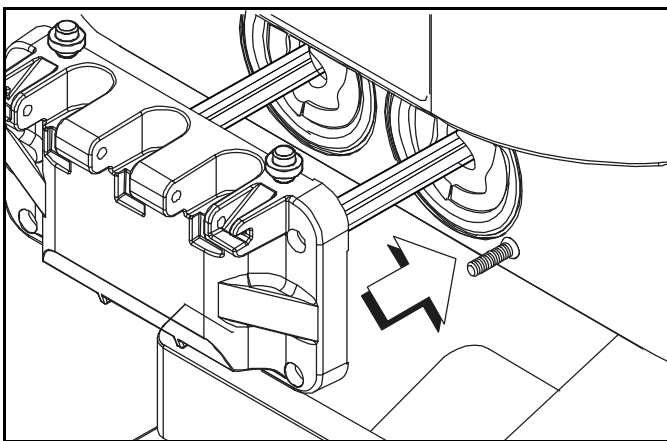

Figure 6-8

With the door seated on the freezer studs, install the handscrews. Use the long handscrews on the top and the short handscrews on the bottom. Tighten

them equally in a crisscross pattern to ensure the door is snug.

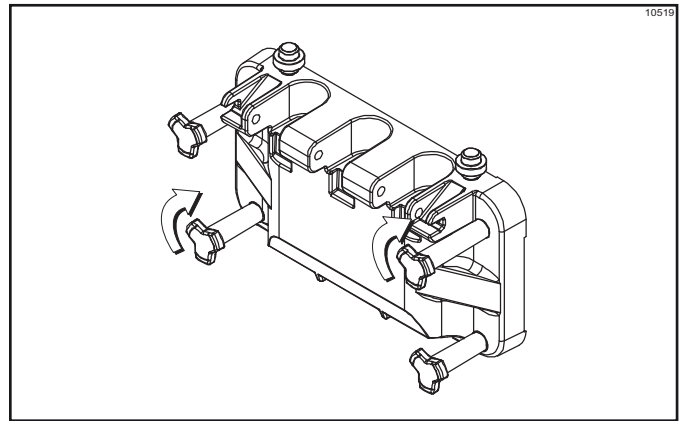

Figure 6-9

14. Slide the three O-rings into the grooves of each standard draw valve. Slide the H-ring and O-ring into the grooves of the center draw valve. Lubricate the H-ring and O-rings.

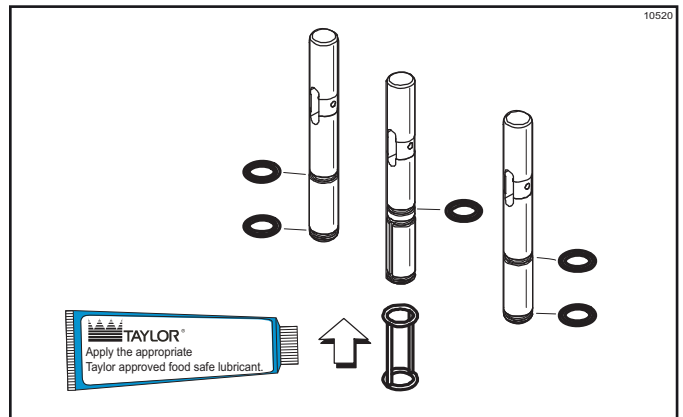

Figure 6-10

15. Lubricate the inside of the freezer door spouts, top and bottom.

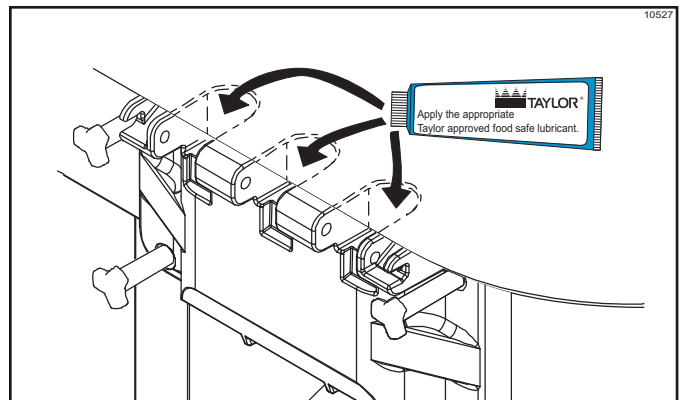

Figure 6-11

16. Insert the draw valves from the bottom until the slot in the draw valves comes into view.

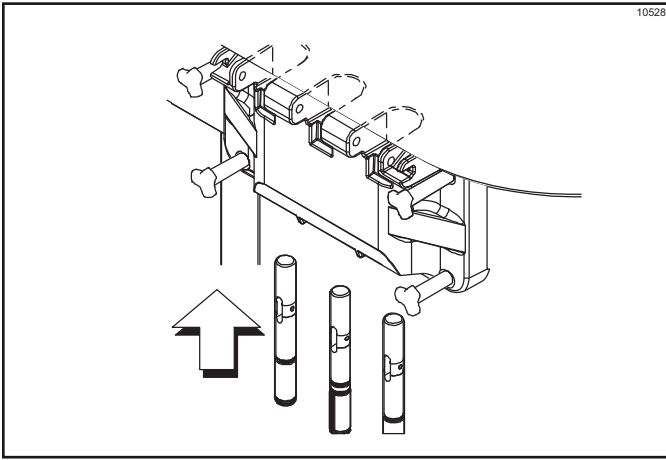

Figure 6-12

17. Slide the fork of the draw handles in the slot of the draw valves, starting from the right.

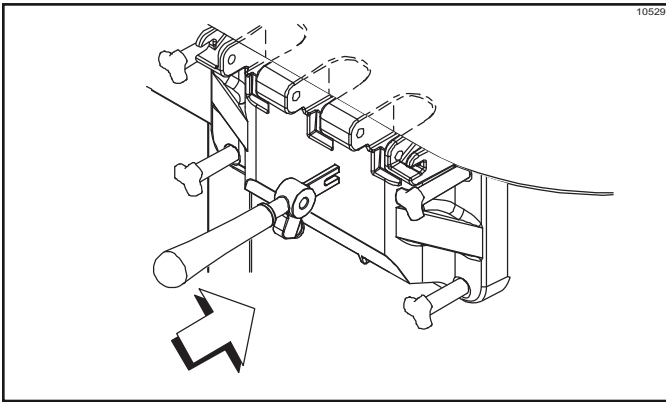

Figure 6-13

18. Slide the pivot pin through each draw handle as they are inserted into the draw valves.

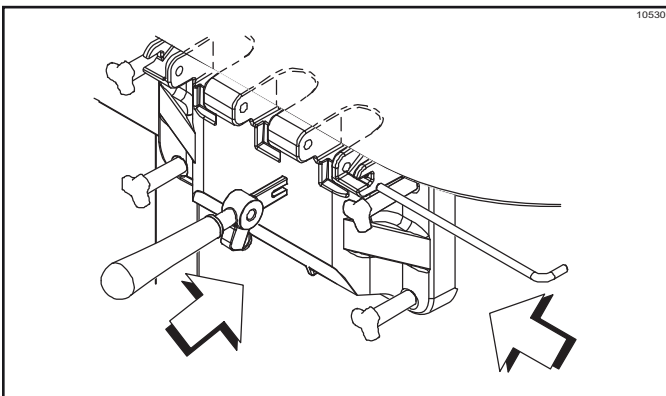

Figure 6-14

Note: This freezer features three adjustable draw handles to provide portion control, giving a better consistent quality to your product and controlling costs. The draw handle should be adjusted to provide a flow rate of 5 oz. to 7-1/2 oz. (142 g to 213 g) of

product by weight per 10 seconds.

To increase the flow rate, turn the adjustment screw **clockwise**. Turn the adjustment screw **counterclockwise** to decrease the flow rate.

19. Snap the design caps over the bottom of the door spouts.

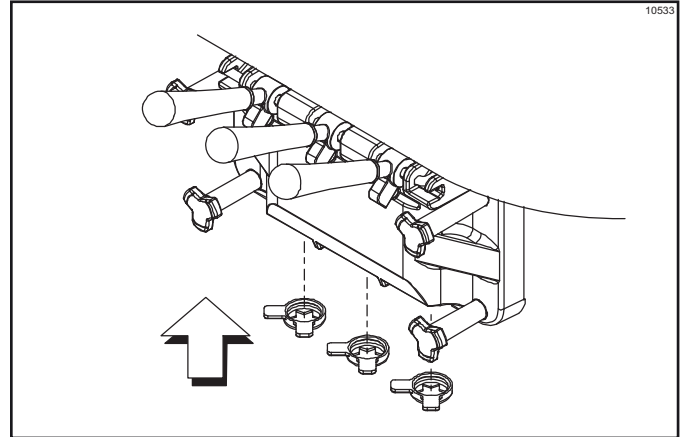

Figure 6-15

20. Slide the two drip pans into the holes in the side panels.

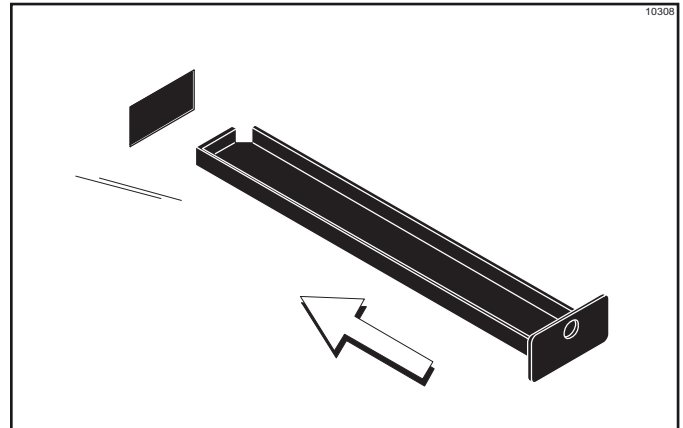

Figure 6-16

21. Install the front drip tray and splash shield under the door spouts.

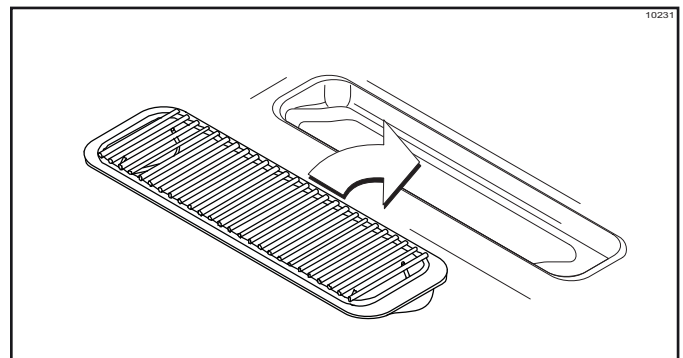

Figure 6-17

22. Slide two O-rings on one end of the feed tube. Slide two O-rings on the other end of the feed tube.

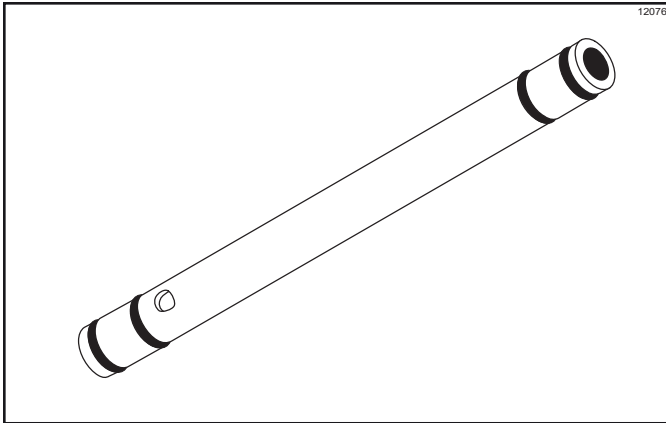

Figure 6-18

23. Slide the small O-ring into the groove of the air orifice. **Do not** lubricate the O-ring.

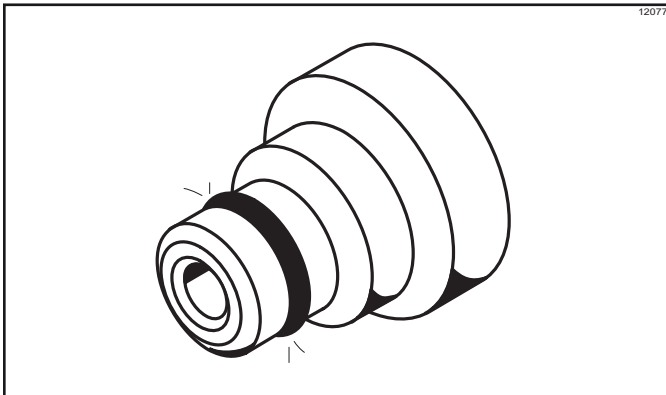

Figure 6-19

Note: Make sure the hole in the air orifice is clean and is not clogged. If the hole in the air orifice should become clogged, use soap and hot water to clear the hole. **Do not** enlarge the hole in the air orifice.

24. Install the air orifice into the hole in the top of the feed tube (end without the small hole on the side).

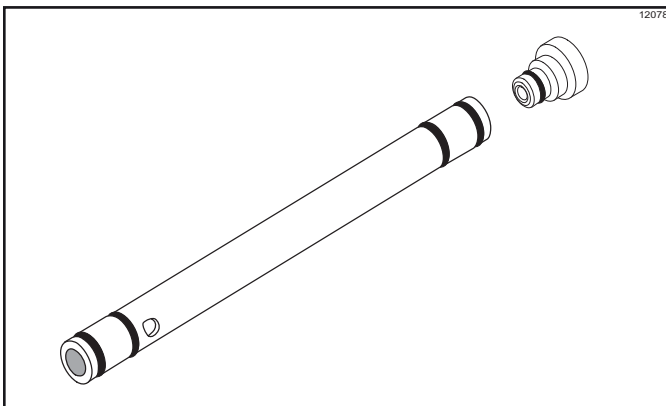

Figure 6-20

25. Lay the feed tube (with the air orifice installed) in the bottom of the mix hopper for sanitizing.

26. Repeat steps 22 through 25 for the other side of the machine.

Sanitizing

1. Prepare an approved 100 PPM sanitizing solution (examples: 2.5 gal. [9.5 L] of Kay-5® or 2 gal. [7.6 L] of Stera-Sheen®). Use warm water and follow the manufacturer's instructions.
2. Pour the sanitizing solution over all the parts in the bottom of the mix hopper and allow it to flow into the freezing cylinder.

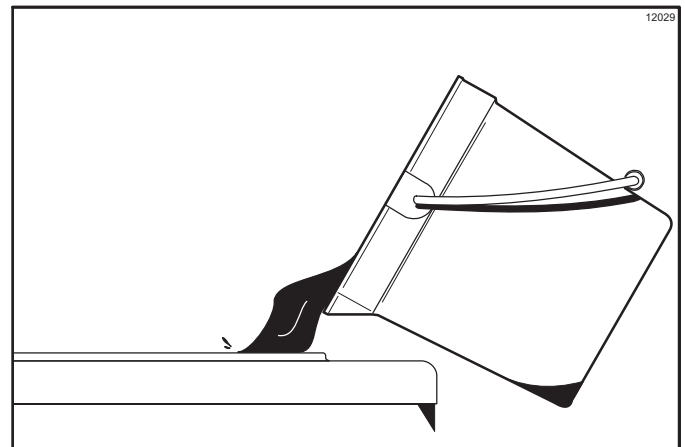

Figure 6-21

Note: Make sure your hands are clean and sanitized before continuing this procedure.

3. While the solution is flowing into the freezing cylinder, take particular care to brush clean the mix level sensing probe on the bottom of the hopper, mix hopper, mix inlet hole, and mix feed tube.

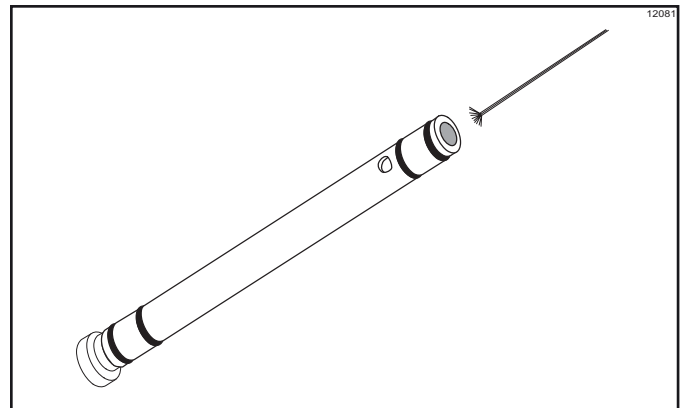



Figure 6-22

OPERATING PROCEDURES

4. Prepare another pail of approved 100 PPM sanitizing solution (examples: 2.5 gal. [9.5 L] of Kay-5® or 2 gal. [7.6 L] of Stera-Sheen®). Use warm water and follow the manufacturer's instructions.
 5. Pour the sanitizing solution into the mix hopper.
 6. Brush the exposed sides of the hopper.
 7. Place the power switch in the ON position.
 8. Touch the WASH symbol . This causes the sanitizing solution in the freezing cylinder to be agitated. Wait at least 5 minutes before proceeding with these instructions.
 9. With an empty pail beneath the door spouts, raise the prime plug.
 10. When a steady stream of sanitizing solution is flowing from the prime plug opening in the bottom of the freezer door, open the draw valve. Momentarily open the center draw valve to sanitize the center door spout. Draw off the remaining sanitizing solution.
 11. Once the sanitizer stops flowing from the door spout, touch the WASH symbol  and close the draw valve.
- Note:** *Make sure your hands are clean and sanitized before continuing this procedure.*
12. Lubricate the feed tube O-rings on the end with the small hole on the side. Stand the feed tube in the corner of the hopper.
 13. Repeat steps 1 through 12 for the other side of the machine.

Priming

Note: *Use only fresh mix when priming the freezer.*

1. Place an empty pail beneath the door spouts. With the prime plug in the UP position, pour 2.5 gal. (9.5 L) of **fresh** mix into the mix hopper and allow it to flow into the freezing cylinder.
2. Open the draw valve to remove all sanitizing solution. When only fresh mix is flowing, close the draw valve.
3. Once a steady stream of mix starts to flow from the prime plug opening in the bottom of the freezer door, push the prime plug down.
4. When mix stops bubbling down into the freezing cylinder, install the end of the feed tube **with the hole in it** into the mix inlet hole in the mix hopper. Make

sure the air orifice is installed in the feed tube.

5. Select the AUTO symbol .
6. Fill the hopper with fresh mix and place the mix hopper cover in position.
7. Repeat steps 1 through 6 for the other side of the machine.

Closing Procedure



ALWAYS FOLLOW LOCAL HEALTH CODES.

To disassemble the Model C713, the following items are needed:

- Two cleaning and sanitizing pails
- Sanitizer/cleaner
- Necessary brushes (provided with freezer)
- Single-service towels

Draining Product from the Freezing Cylinder

1. Remove the hopper cover and the feed tube. Take them to the sink for cleaning.
2. With a pail beneath the door spouts, touch the WASH symbol  and open the draw valve.
3. **If local health codes permit the use of rerun**, place a sanitized, NSF-approved stainless steel rerun container beneath the door spout. Press the WASH key and open the draw valve. Drain the remaining product from the freezing cylinder and mix hopper. When the flow of product stops, press the WASH key and close the draw valve. Place the sanitized lid on the rerun container and place it in the walk-in cooler.

Note: *If local health codes **do not** permit the use of rerun, the product must be discarded. Follow the instructions in the previous step, except drain the product into a pail and properly discard the mix.*



ALWAYS FOLLOW LOCAL HEALTH CODES.

4. Repeat steps 1 through 3 for the other side of the machine.

Rinsing

1. Pour 2 gal. (7.6 L) of cool, clean water into the mix hopper. With the white hopper brush, scrub the mix hopper and the mix level sensing probe. Using the double-ended brush, brush clean the mix inlet hole.

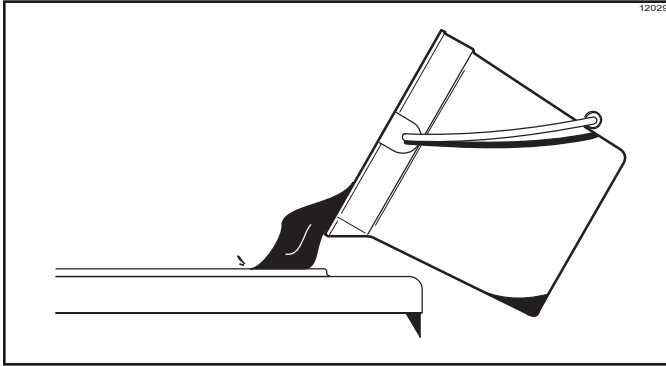



Figure 6-23

Note: *Do not brush clean the mix inlet hole while the machine is in the Wash mode.*

2. With a pail beneath the door spout, raise the prime plug and touch the WASH symbol .
3. When a steady stream of rinse water is flowing from the prime plug opening in the bottom of the freezer door, open the draw valve. Drain all the rinse water from the door spout. Close the draw valve, and touch the WASH symbol , cancelling the Wash mode.
4. Repeat steps 1 through 3 using clean, warm water until the water being discharged is clear.
5. Repeat steps 1 through 4 for the other side of the machine.



Hopper Cleaning

Note: *Failure to follow these steps results in milkstone buildup.*

1. Prepare an approved 100 PPM cleaning solution (examples: 2.5 gal. [9.5 L] of Kay-5® or 2 gal. [7.6 L] of Stera-Sheen®). Use warm water and follow the manufacturer's specifications.
2. Push the prime plug down. Pour the cleaning solution into the hopper and allow it to flow into the freezing cylinder.

3. Using the white hopper brush, clean the mix hopper and the mix level sensing probes. Using the double ended brush, clean the mix inlet hole.

Note: *Do not brush clean the mix inlet hole while the machine is in the Wash mode.*

4. Touch the WASH symbol . This causes the cleaning solution in the freezing cylinder to come in contact with all areas of the freezing cylinder.
5. Place an empty pail beneath the door spouts and raise the prime plug.
6. When a steady stream of cleaning solution is flowing from the prime plug opening in the bottom of the freezer door, open the draw valve. Draw off all the solution.
7. Once the cleaning solution stops flowing from the door spout, close the draw valve and touch the WASH symbol , canceling the Wash mode.
8. Repeat steps 1 through 7 for the other side of the machine.

Disassembly

1. Place the power switch in the OFF position.
2. Remove the handscrews, freezer door, beater and scraper blades, and drive shaft with drive shaft seal from the freezing cylinder.
3. Remove the scraper blades from the beater assembly.
4. Remove the drive shaft seal from the drive shaft.
5. Remove the freezer door gasket, front bearing, pivot pin, draw handle, draw valve, prime plugs, and design caps. Remove the three O-rings from the draw valve.
6. Repeat steps 1 through 5 for the other side of the machine.
7. Remove the front drip tray and splash shield.
8. Remove all drip pans. Take them to the sink for cleaning.

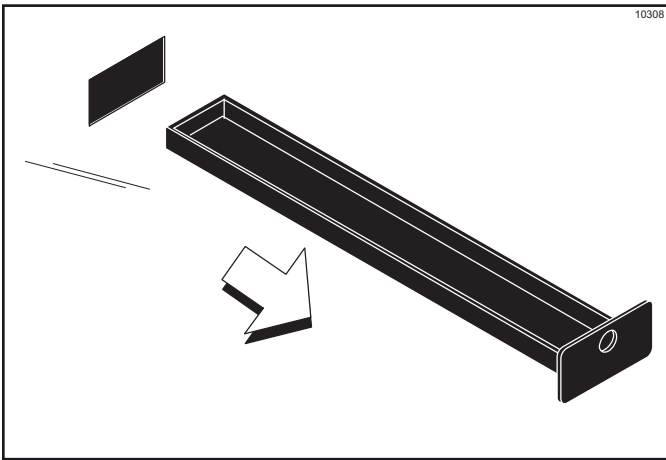

Figure 6-24

Note: If the drip pans are filled with an excessive amount of mix, it is an indication that the drive shaft seal(s) or O-ring(s) should be replaced or properly lubricated.

Manual Brush Cleaning

These procedures must be completed according to the frequency specified by your federal, state, or local regulatory agencies. Consult your governing food code to determine the maximum number of days allowed between brush clean cycles.

- 6** Use the recommended cleaning procedure outlined in the manual or an alternate procedure used in conjunction with a cleaning/sanitizing system that has been certified by NSF.



1. Prepare an approved 100 PPM cleaning solution (examples: 2.5 gal. [9.5 L] of Kay-5® or 2 gal. [7.6 L] of Stera-Sheen®). Use warm water and follow the manufacturer's specifications. Make sure all brushes provided with the freezer are available for brush cleaning.
2. Thoroughly brush clean all disassembled parts in the cleaning solution, making sure all lubricant and mix film is removed. Be sure to brush all surfaces and holes, especially the holes in the freezer door.
3. Rinse all parts with clean, warm water. Place the parts on a clean, dry surface to air dry overnight.
4. Return to the freezer with a small amount of cleaning solution. Using the black brush, clean the rear shell bearing at the back of the freezing cylinder.

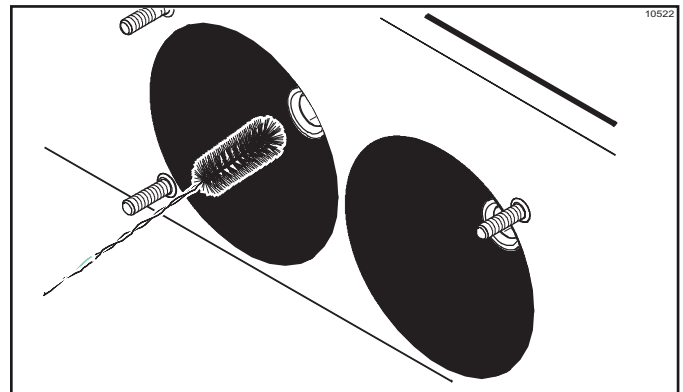

Figure 6-25

5. Repeat steps 1 through 4 for the other side of the machine.
6. Wipe all exterior surfaces of the freezer with a clean, sanitized towel.

During Cleaning and Sanitizing



ALWAYS FOLLOW LOCAL HEALTH CODES.

Cleaning and sanitizing schedules are governed by federal, state, or local regulatory agencies, and must be followed accordingly. If the unit has a Standby mode, it must not be used in lieu of proper cleaning and sanitizing procedures and frequencies set forth by the ruling health authority. The following checkpoints should be stressed during the cleaning and sanitizing operations.

Troubleshooting Bacterial Count

- Thoroughly clean and sanitize machine regularly, including complete disassembly and brush cleaning.
- Use all brushes supplied for thorough cleaning. The brushes are specially designed to reach all mix passageways.
- Use the white bristle brush to clean the mix inlet hole which extends from the mix hopper down to the rear of the freezing cylinder.
- Use the black bristle brush to thoroughly clean the rear shell bearing located at the rear of the freezing cylinder. Make sure there is a generous amount of cleaning solution on the brush.
- If local health codes permit the use of rerun**, make sure the mix rerun is stored in a sanitized, covered, NSF-approved stainless steel container and is used the following day. **Do not** prime the machine with rerun. When using rerun, skim off the foam and discard. Then mix the rerun with **fresh** mix in a ratio of 50/50 during the day's operation.
- On a designated day of the week, run the mix as low as feasible and discard after closing. This will break the rerun cycle and reduce the possibility of high bacteria and coliform counts.
- Properly prepare the cleaning and sanitizing solutions. Read and follow label directions carefully. Too **strong** of a solution may damage the parts and too **weak** of a solution will not do an

adequate job of cleaning or sanitizing.

- The temperature of mix in mix hopper and walk-in cooler should be below 40°F (4.4°C).

Regular Maintenance Checks

- Replace scraper blades that are nicked or damaged. Before installing the beater assembly, make sure scraper blades are properly attached to the helix.
- Check the rear shell bearing for signs of wear (excessive mix leakage in rear drip pan) and make sure it is properly cleaned.
- Using a screwdriver and cloth towel, keep the rear shell bearing and female hex drive socket clean and free of lubricant and mix deposits.
- Dispose of O-rings and seals if they are worn, torn, or fit too loosely, and replace with new ones.
- Follow all lubricating procedures as outlined in "Freezing Cylinder Assembly" on page 6-1.
- If your machine is air-cooled, check the condensers for accumulation of dirt and lint. Dirty condensers will reduce the efficiency and capacity of the machine. Condensers should be cleaned **monthly** with a soft brush.

Never use screwdrivers or other metal probes to clean between the fins.

For machines equipped with an air filter, it will be necessary to vacuum clean the filters on a monthly schedule.



WARNING! Always disconnect electrical power prior to cleaning the condenser. Failure to follow this instruction may result in electrocution.

- If your machine is water-cooled, check the water lines for kinks or leaks. Kinks can occur when the machine is moved back and forth for cleaning or maintenance purposes. Deteriorated or cracked water lines should be replaced only by an authorized Taylor distributor.

Winter Storage

If the place of business is to be closed during the winter months, it is important to protect the freezer by following certain precautions, particularly if the building is subject to freezing conditions.

Disconnect the freezer from the main power source to prevent possible electrical damage.

On water-cooled freezers, disconnect the water supply. Relieve pressure on the spring in the water valve. Use air pressure on the outlet side to blow out any water remaining in the condenser. **This is extremely important.** Failure to follow this procedure may cause severe and costly damage to the refrigeration system.

Your local Taylor distributor can perform this winter storage service for you.

Wrap detachable parts of the freezer, such as the beater, blades, drive shaft, and freezer door, and place them in a protected dry place. Rubber trim parts and gaskets can be protected by wrapping them with moisture-proof paper. All parts should be thoroughly cleaned of dried mix or lubrication, which attract mice and other vermin.

It is recommended that an authorized service technician perform winter storage draining to ensure all water has been removed. This will guard against freezing and rupturing of the components.

Table 8-1

Problem	Probable Cause	Remedy	Page Ref.
1. No product is being dispensed.	<ul style="list-style-type: none"> a. Low on mix. The MIX OUT light is on. b. The power switch is in the OFF position. c. Machine not in Auto mode. d. Beater motor is out on reset. The BEATER OVERLOAD message displayed. e. Freeze-up in mix inlet hole. f. Feed tube is not properly installed. 	<ul style="list-style-type: none"> a. Add mix to the mix hopper. Return to Auto mode. b. Place the power switch to ON and select AUTO. c. Select AUTO and allow machine to cycle off before drawing product. d. Turn the machine off. Press the reset button. Restart the machine in AUTO. e. Call an authorized service technician. f. Make sure feed tube is properly installed. 	<ul style="list-style-type: none"> 6-6 6-6 6-6 - - - - - - 6-6
2. The product is too soft.	<ul style="list-style-type: none"> a. Draw rate is set too fast. 	<ul style="list-style-type: none"> a. Adjust draw rate of 5 oz. to 7.5 oz. (142 g to 213 g) of product by weight in 10 seconds. 	<ul style="list-style-type: none"> 6-4
3. The product is too thick.	<ul style="list-style-type: none"> a. Freezing cylinder not primed correctly. b. The viscosity control is set too cold. c. Freeze-up in mix inlet hole. 	<ul style="list-style-type: none"> a. Drain the freezing cylinder and reprime the machine. b. Call an authorized service technician. c. Call an authorized service technician. 	<ul style="list-style-type: none"> 6-6 - - - - - -
4. The mix in the hopper is too warm.	<ul style="list-style-type: none"> a. Hopper cover is not in position. b. The hopper temperature is out of adjustment. 	<ul style="list-style-type: none"> a. Clean and sanitize hopper cover and place in position. b. Call an authorized service technician. 	<ul style="list-style-type: none"> 6-6 - - -
5. The mix in the hopper is too cold.	<ul style="list-style-type: none"> a. The hopper temperature is out of adjustment. 	<ul style="list-style-type: none"> a. Call an authorized service technician. 	<ul style="list-style-type: none"> - - -
6. Mix Low and Mix Out probes are not functioning.	<ul style="list-style-type: none"> a. Milkstone buildup in the hopper. 	<ul style="list-style-type: none"> a. Clean hoppers thoroughly. 	<ul style="list-style-type: none"> 6-8
7. Product is collecting on top of the freezer door.	<ul style="list-style-type: none"> a. The top O-ring on draw valve is improperly lubricated or worn. 	<ul style="list-style-type: none"> a. Lubricate properly or replace the O-ring. 	<ul style="list-style-type: none"> 6-3
8. Excessive mix leakage from the bottom of door spout.	<ul style="list-style-type: none"> a. Bottom O-ring on draw valve is improperly lubricated or worn. 	<ul style="list-style-type: none"> a. Lubricate properly or replace the O-ring. 	<ul style="list-style-type: none"> 6-3
9. Excessive mix leakage into the long drip pan.	<ul style="list-style-type: none"> a. The seal on drive shaft is improperly lubricated or worn. b. The seal is installed inside-out on the drive shaft. c. Inadequate lubrication of the drive shaft. d. The drive shaft and beater assembly work forward. e. Worn rear shell bearing. f. Gear box out of alignment. 	<ul style="list-style-type: none"> a. Lubricate properly or replace the seal. b. Install correctly. c. Lubricate properly. d. Call an authorized service technician. e. Call an authorized service technician. f. Call an authorized service technician. 	<ul style="list-style-type: none"> 6-1 6-1 6-1 - - - - - - - - -

TROUBLESHOOTING GUIDE

Problem	Probable Cause	Remedy	Page Ref.
10.The drive shaft is stuck in the drive coupling.	a. Mix and lubricant collected in drive coupling.	a. Brush clean the rear shell bearing area regularly.	6-8
	b. Rounded corners of drive shaft, drive coupling, or both.	b. Call an authorized service technician.	- - -
	c. Gear box is out of alignment.	c. Call an authorized service technician.	- - -
11.The freezing cylinder walls are scored.	a. Missing or worn front bearing.	a. Install or replace the front bearing.	6-2
	b. Broken freezer door baffle rod.	b. Replace freezer door.	6-3
	c. Beater assembly is bent.	c. Replace beater assembly.	6-3
	d. Gear box is out of alignment.	d. Call an authorized service technician.	- - -
12.The product makes a popping sound when drawn.	a. Draw rate is set too fast.	a. Adjust draw rate of 5 oz to 7.5 oz. (142 g to 213 g) of product by weight in 10 seconds.	6-4
	b. Freezing cylinder not primed correctly.	b. Drain the freezing cylinder and reprime the machine.	6-6
13.No control panel functions with power switch ON.	a. Machine is unplugged.	a. Plug into wall receptacle.	- - -
	b. Circuit breaker OFF or blown fuse.	b. Turn the breaker ON or replace the fuse.	- - -

Section 9

Parts Replacement Schedule

Table 9-1

Part Description	Every 3 Months	Every 6 Months	Annually
Scraper Blade	X		
Drive Shaft Seal	X		
Freezer Door Gasket	X		
Front Bearing	X		
Draw Valve O-Ring	X		
Draw Valve Seal	X		
Prime Plug O-Ring	X		
Mix Feed Tube O-Ring	X		
Design Cap	X		
White Bristle Brush, 3" x 7"		Inspect and replace if necessary.	Minimum
White Bristle Brush, 1" x 2"		Inspect and replace if necessary.	Minimum
Black Bristle Brush, 1" x 2"		Inspect and replace if necessary.	Minimum
Double-Ended Brush		Inspect and replace if necessary.	Minimum
Baffle-Threadless Molded		Inspect and replace if necessary.	

TAYLOR COMPANY LIMITED WARRANTY ON FREEZERS

Taylor Company, is pleased to provide this limited warranty on new Taylor-branded freezer equipment available from Taylor to the market generally (the "Product") to the original purchaser only.

LIMITED WARRANTY

Taylor warrants the Product against failure due to defect in materials or workmanship under normal use and service as follows. All warranty periods begin on the date of original Product installation. If a part fails due to defect during the applicable warranty period, Taylor, through an authorized Taylor distributor or service agency, will provide a new or re-manufactured part, at Taylor's option, to replace the failed defective part at no charge for the part. Except as otherwise stated herein, these are Taylor's exclusive obligations under this limited warranty for a Product failure. This limited warranty is subject to all provisions, conditions, limitations and exclusions listed below and on the reverse (if any) of this document.

Table 10-1

Product	Part	Limited Warranty Period
Soft Serve	Insulated shell assembly	Five (5) years
Frozen Yogurt Shakes	Refrigeration compressor (except service valve)	Five (5) years
Smoothies	Beater motors	Two (2) years
Frozen Beverage	Beater drive gear	Two (2) years
Batch Desserts	Printed circuit boards and Softech controls beginning with serial number H8024200	Two (2) years
	Parts not otherwise listed in this table or excluded below	One (1) year

LIMITED WARRANTY CONDITIONS

1. If the date of original installation of the Product cannot be verified, then the limited warranty period begins ninety (90) days from the date of Product manufacture (as indicated by the Product serial number). Proof of purchase may be required at time of service.
2. This limited warranty is valid only if the Product is installed and all required service work on the Product is performed by an authorized Taylor distributor or service agency, and only if genuine, new Taylor parts are used.
3. Installation, use, care, and maintenance must be normal and in accordance with all instructions contained in the Taylor Operator's Manual.
4. Defective parts must be returned to the authorized Taylor distributor or service agency for credit.
5. The use of any refrigerant other than that specified on the Product's data label will void this limited warranty.

LIMITED WARRANTY EXCEPTIONS

This limited warranty does **not** cover:

1. Labor or other costs incurred for diagnosing, repairing, removing, installing, shipping, servicing, or handling of defective parts, replacement parts, or new Products.
2. Normal maintenance, cleaning, and lubrication as outlined in the Taylor Operator's Manual, including cleaning of condensers.
3. Replacement of wear items designated as Class "000" parts in the Taylor Operator's Manual.
4. External hoses, electrical power supplies, and machine grounding.

LIMITED WARRANTY ON EQUIPMENT

5. Parts not supplied or designated by Taylor, or damages resulting from their use.
6. Return trips or waiting time required because a service technician is prevented from beginning warranty service work promptly upon arrival.
7. Failure, damage, or repairs due to faulty installation, misapplication, abuse, no or improper servicing, unauthorized alteration, or improper operation or use as indicated in the Taylor Operator's Manual, including but not limited to the failure to use proper assembly and cleaning techniques, tools, or approved cleaning supplies.
8. Failure, damage, or repairs due to theft, vandalism, wind, rain, flood, high water, water, lightning, earthquake or any other natural disaster, fire, corrosive environments, insect or rodent infestation, or other casualty, accident or condition beyond the reasonable control of Taylor; operation above or below the electrical or water supply specification of the Product; or components repaired or altered in any way so as, in the judgment of the Manufacturer, to adversely affect performance, or normal wear or deterioration.
9. Any Product purchased over the Internet.
10. Failure to start due to voltage conditions, blown fuses, open circuit breakers, or damages due to the inadequacy or interruption of electrical service.
11. Electricity or fuel costs, or increases in electricity or fuel costs from any reason whatsoever.
12. Damages resulting from the use of any refrigerant other than that specified on the Product's data label will void this limited warranty.
13. Any cost to replace, refill or dispose of refrigerant, including the cost of refrigerant.
14. **ANY SPECIAL, INDIRECT OR CONSEQUENTIAL PROPERTY OR COMMERCIAL DAMAGE OF ANY NATURE WHATSOEVER.** Some jurisdictions do not allow the exclusion of incidental or consequential damages, so this limitation may not apply to you.

This limited warranty gives you specific legal rights, and you may also have other rights which vary from jurisdiction to jurisdiction.

LIMITATION OF WARRANTY

THIS LIMITED WARRANTY IS EXCLUSIVE AND IS IN LIEU OF ALL OTHER WARRANTIES, CONDITIONS AND/OR REMEDIES UNDER THE LAW, INCLUDING ANY IMPLIED WARRANTIES OR CONDITIONS OF MERCHANTABILITY OR FITNESS FOR A PARTICULAR PURPOSE. THE ORIGINAL OWNER'S SOLE REMEDY WITH RESPECT TO ANY PRODUCTS SHALL BE REPAIR OR REPLACEMENT OF DEFECTIVE COMPONENTS UNDER THE TERMS OF THIS LIMITED WARRANTY. ALL RIGHTS TO CONSEQUENTIAL OR INCIDENTAL DAMAGES (INCLUDING CLAIMS FOR LOST SALES, LOST PROFITS, PRODUCT LOSS, PROPERTY DAMAGES OR SERVICE EXPENSES) ARE EXPRESSLY EXCLUDED. THE EXPRESS WARRANTIES MADE IN THIS LIMITED WARRANTY MAY NOT BE ALTERED, ENLARGED, OR CHANGED BY ANY DISTRIBUTOR, DEALER, OR OTHER PERSON, WHATSOEVER.

LEGAL REMEDIES

The owner **must** notify Taylor in writing, by certified or registered letter to the following address, of any defect or complaint with the Product, stating the defect or complaint and a specific request for repair, replacement, or other correction of the Product under warranty, mailed at least thirty (30) days before pursuing any legal rights or remedies.

Taylor Company
750 N. Blackhawk Blvd.
Rockton, IL 61072, U.S.A.

TAYLOR COMPANY LIMITED WARRANTY ON TAYLOR GENUINE PARTS

Taylor Company, is pleased to provide this limited warranty on new Taylor genuine replacement components and parts available from Taylor to the market generally (the "Parts") to the original purchaser only.

LIMITED WARRANTY

Taylor warrants the Parts against failure due to defect in materials or workmanship under normal use and service as follows. All warranty periods begin on the date of original installation of the Part in the Taylor unit. If a Part fails due to defect during the applicable warranty period, Taylor, through an authorized Taylor distributor or service agency, will provide a new or re-manufactured Part, at Taylor's option, to replace the failed defective Part at no charge for the Part. Except as otherwise stated herein, these are Taylor's exclusive obligations under this limited warranty for a Part failure. This limited warranty is subject to all provisions, conditions, limitations and exclusions listed below and on the reverse (if any) of this document.

Table 11-1

Part's Warranty Class Code or Part	Limited Warranty Period
Class 103 Parts ¹	Three (3) Months
Class 212 Parts ²	Twelve (12) Months
Class 512 Parts	Twelve (12) Months
Class 000 Parts	No Warranty

LIMITED WARRANTY CONDITIONS

1. If the date of original installation of the Part cannot be otherwise verified, proof of purchase may be required at time of service.
2. This limited warranty is valid only if the Part is installed and all required service work in connection with the Part is performed by an authorized Taylor distributor or service agency.
3. The limited warranty applies only to Parts remaining in use by their original owner at their original installation location in the unit of original installation.
4. Installation, use, care, and maintenance must be normal and in accordance with all instructions contained in the Taylor Operator's Manual.
5. Defective Parts must be returned to the authorized Taylor distributor or service agency for credit.
6. This warranty is not intended to shorten the length of any warranty coverage provided pursuant to a separate Taylor Limited Warranty on freezer or grill equipment.
7. The use of any refrigerant other than that specified for the unit in which the Part is installed will void this limited warranty.

^{1, 2} Except that Taylor Part #032129SER2 (Compressor-Air-230V SERV) and Taylor Part #075506SER1 (Compressor-Air-115V 60HZ) shall have a limited warranty period of twelve (12) months when used in Taylor freezer equipment and a limited warranty period of two (2) years when used in Taylor grill equipment.

LIMITED WARRANTY ON PARTS

LIMITED WARRANTY EXCEPTIONS

This limited warranty does **not** cover:

1. Labor or other costs incurred for diagnosing, repairing, removing, installing, shipping, servicing or handling of defective Parts, replacement Parts, or new Parts.
2. Normal maintenance, cleaning and lubrication as outlined in the Taylor Operator's Manual, including cleaning of condensers or carbon and grease buildup.
3. Required service, whether cleaning or general repairs, to return the cooking surface assemblies, including the upper platen and lower plate, to an operational condition to achieve proper cooking or allow proper assembly of release sheets and clips as a result of grease build-up on the cooking surfaces, including but not limited to the platen and plate, sides of the shroud or top of the shroud.
4. Replacement of cooking surfaces, including the upper platen and lower plate, due to pitting or corrosion (or in the case of the upper platen, due to loss of plating) as a result of damage due to the impact of spatulas or other small wares used during the cooking process or as a result of the use of cleaners, cleaning materials or cleaning processes not approved for use by Taylor.
5. Replacement of wear items designated as Class "000" Parts in the Taylor Operator's Manual, as well as any release sheets and clips for the Product's upper platen assembly.
6. External hoses, electrical power supplies, and machine grounding.
7. Parts not supplied or designated by Taylor, or damages resulting from their use.
8. Return trips or waiting time required because a service technician is prevented from beginning warranty service work promptly upon arrival.
9. Failure, damage or repairs due to faulty installation, misapplication, abuse, no or improper servicing, unauthorized alteration or improper operation or use as indicated in the Taylor Operator's Manual, including but not limited to the failure to use proper assembly and cleaning techniques, tools, or approved cleaning supplies.
10. Failure, damage or repairs due to theft, vandalism, wind, rain, flood, high water, water, lightning, earthquake or any other natural disaster, fire, corrosive environments, insect or rodent infestation, or other casualty, accident or condition beyond the reasonable control of Taylor; operation above or below the gas, electrical or water supply specification of the unit in which a part is installed; or Parts or the units in which they are installed repaired or altered in any way so as, in the judgment of Taylor, to adversely affect performance, or normal wear or deterioration.
11. Any Part purchased over the Internet.
12. Failure to start due to voltage conditions, blown fuses, open circuit breakers, or damages due to the inadequacy or interruption of electrical service.
13. Electricity, gas or other fuel costs, or increases in electricity or fuel costs from any reason whatsoever.
14. Damages resulting from the use of any refrigerant other than that specified for the unit in which the Part is installed will void this limited warranty.
15. Any cost to replace, refill or dispose of refrigerant, including the cost of refrigerant.
16. **ANY SPECIAL, INDIRECT OR CONSEQUENTIAL PROPERTY OR COMMERCIAL DAMAGE OF ANY NATURE WHATSOEVER.** Some jurisdictions do not allow the exclusion of incidental or consequential damages, so this limitation may not apply to you.

This limited warranty gives you specific legal rights, and you may also have other rights which vary from jurisdiction to jurisdiction.

LIMITATION OF WARRANTY

THIS LIMITED WARRANTY IS EXCLUSIVE AND IS IN LIEU OF ALL OTHER WARRANTIES, CONDITIONS AND/ OR REMEDIES UNDER THE LAW, INCLUDING ANY IMPLIED WARRANTIES OR CONDITIONS OF MERCHANTABILITY OR FITNESS FOR A PARTICULAR PURPOSE. THE ORIGINAL OWNER'S SOLE REMEDY WITH RESPECT TO ANY PRODUCTS SHALL BE REPAIR OR REPLACEMENT OF DEFECTIVE PARTS UNDER THE TERMS OF THIS LIMITED WARRANTY. ALL RIGHTS TO CONSEQUENTIAL OR INCIDENTAL DAMAGES (INCLUDING CLAIMS FOR LOST SALES, LOST PROFITS, PRODUCT LOSS, PROPERTY DAMAGES OR SERVICE EXPENSES) ARE EXPRESSLY EXCLUDED. THE EXPRESS WARRANTIES MADE IN THIS LIMITED WARRANTY MAY NOT BE ALTERED, ENLARGED, OR CHANGED BY ANY DISTRIBUTOR, DEALER, OR OTHER PERSON, WHATSOEVER.

LEGAL REMEDIES

The owner **must** notify Taylor in writing, by certified or registered letter to the following address, of any defect or complaint with the Part, stating the defect or complaint and a specific request for repair, replacement, or other correction of the Part under warranty, mailed at least thirty (30) days before pursuing any legal rights or remedies.

Taylor Company
750 N. Blackhawk Blvd.
Rockton, IL 61072, U.S.A.

