

OPERATOR'S MANUAL



Model C303 & C314 Slush Freezer

Original Operating Instructions

066732-M

08/19/10 (Original Publication)
(Updated 7/23/2019)

Section 1: To the Installer

Installer Safety	1-1
Site Preparation	1-1
Air-Cooled Units	1-2
Water-Cooled Refrigeration Units	1-2
Water Connections	1-2
Electrical Connections.	1-3
Beater Rotation	1-3
Initial Freezing Cylinder Cleaning	1-4
Refrigerant	1-4

Section 2: To the Operator

Compressor Warranty Disclaimer	2-2
--	-----

Section 3: Safety

Section 4: Operator Parts Identification

C303	4-1
Model C314.	4-2
Beater Door Assembly	4-3
Accessories.	4-4

Section 5: User Interface

Control Switch.	5-1
Liquid Crystal Display	5-1
Operational Mode Displays.	5-2
Operator Menu Display	5-2
Beater Recovery Display.	5-3
Operator Menu Timeout	5-3
Finding Current Fault Conditions	5-3
Syrup Out Indicator	5-9
CO2 Out Indicator	5-9
Water Out Indicator.	5-9
Audio Alarm Silencer.	5-9
Product Light.	5-10
Sampling Valve	5-10
Daily Procedures.	5-10

Table of Contents

Section 6: Operating Procedures

Assembly	6-1
Sanitizing	6-5
Priming/Brixing	6-7
120 Day Closing Procedure	6-10
Draining Product from the Freezing Cylinders	6-10
Rinsing	6-10
Cleaning	6-11
Disassembly	6-12
Brush Cleaning	6-12

Section 7: Operator Checklist

During Cleaning and Sanitizing	7-1
Troubleshooting Bacterial Count	7-1
Regular Maintenance Checks	7-1
Winter Storage	7-1

Section 8: Troubleshooting Guide

Section 9: Parts Replacement Schedule

Section 10: Limited Warranty on Equipment

Section 11: Limited Warranty on Parts

The following information has been included in the manual as safety and regulatory guidelines. For complete installation instructions, please see the Installation Checklist.

Installer Safety



IMPORTANT! In all areas of the world, equipment should be installed in accordance with existing local codes. Please contact your local authorities if you have any questions.

Care should be taken to ensure that all basic safety practices are followed during the installation and servicing activities related to the installation and service of Taylor equipment.

- Only authorized Taylor service personnel should perform installation and repairs on the equipment.
- Authorized service personnel should consult OSHA Standard 29CFR1910.147 or the applicable code of the local area for the industry standards on lockout/tagout procedures before beginning any installation or repairs.
- Authorized service personnel must ensure that the proper PPE is available and worn when required during installation and service.
- Authorized service personnel must remove all metal jewelry, rings, and watches before working on electrical equipment.



DANGER! The main power supply(s) to the freezer must be disconnected prior to performing any repairs. Failure to follow this instruction may result in personal injury or death from electrical shock or hazardous moving parts as well as poor performance or damage to the equipment.

Note: All repairs must be performed by an authorized Taylor service technician.



WARNING! This unit has many sharp edges that can cause severe injuries.

Site Preparation

Review the area where the unit will be installed before uncrating the unit. Make sure all possible hazards to the user or equipment have been addressed.

For Indoor Use Only: This unit is designed to operate indoors, under normal ambient temperatures of 70°F to 75°F (21°C to 24°C). The freezer has successfully performed in high ambient temperatures of 104°F (40°C) at reduced capacities.



WARNING! This unit must **NOT** be installed in an area where a water jet or hose can be used. **NEVER** use a water jet or hose to rinse or clean the unit. Failure to follow this instruction may result in electrocution.



CAUTION! This unit must be installed on a level surface to avoid the hazard of tipping. Extreme care should be taken in moving this equipment for any reason. Two or more persons are required to safely move this unit. Failure to comply may result in personal injury or equipment damage.

Uncrate the unit and inspect it for damage. Report any damage to your Taylor distributor.

This piece of equipment is made in the USA and has USA sizes of hardware. All metric conversions are approximate and vary in size.

Air-Cooled Units

Air-cooled units require a minimum of 3 in. (76 mm) of airspace on both sides, 3 in. (76 mm) at the rear and 12 in. (305 mm) on the top of the unit. Minimum air clearances must be met to assure adequate airflow for optimum performance.

1 Water-Cooled Refrigeration Units

On the back of the unit, two additional 3/8 in. (9.5 mm) F.P.T. water connections for condenser inlet and outlet have been provided for easy hookup. 3/8 in. (9.5 mm) inside diameter water lines should be connected to the machine. Flexible lines are recommended, if local codes permit. Failure to use adequate size water lines may cause the unit to go on high head pressure and shut down.

Depending on local water conditions, it may be advisable to install a water strainer to prevent foreign substances from clogging the automatic water valve.

Do not install a hand shutoff valve on the out line.

Water-cooled units are counter flow, and the water should flow in this order: first, through the automatic water valve; second, through the inlet located at the bottom of the condenser; and third, through the outlet fitting located at the top of the condenser to an open trap drain.

Important! Water pressures are pre-set at the factory. Do not adjust the water pressure. Improper water adjustments may cause operation discrepancies.

Water Connections

An adequate cold water supply must be provided with a hand shutoff valve. On the back of the unit, a 3/8 in. (9.5 mm) MFL. water connection has been provided for easy hookup. A flexible line is recommended, if local codes permit. A minimum of 25 psi (172 kPa) water pressure is required to avoid having the unit cut out the low water pressure switch. A booster pump must be provided if this pressure is not available.

Note: Water lines beyond 200 ft. (61 m) require 1/2 in. (13 mm) water lines.



IMPORTANT! A backflow prevention device is required on the incoming water connection side. Please use the applicable national, state, and local codes for determining the proper configuration.

It is always a good practice to have a filter system to improve the quality of the water and to avoid clogging the operating components.

Important! The water filter (064422-SER) must be thoroughly flushed with water before connecting it to the machine.

This removes any loose particles present from the manufacture of the filter that could clog the flow control.

1. To flush the filter, connect the inlet end of the filter to the water supply.
2. Position the outlet end of the filter over an empty pail.
3. Open the water supply. Allow water to flow through the filter until the water exiting the filter is clear.
4. Close the water supply.
5. Attach the outlet end of the filter to the machine. Reopen the water supply.

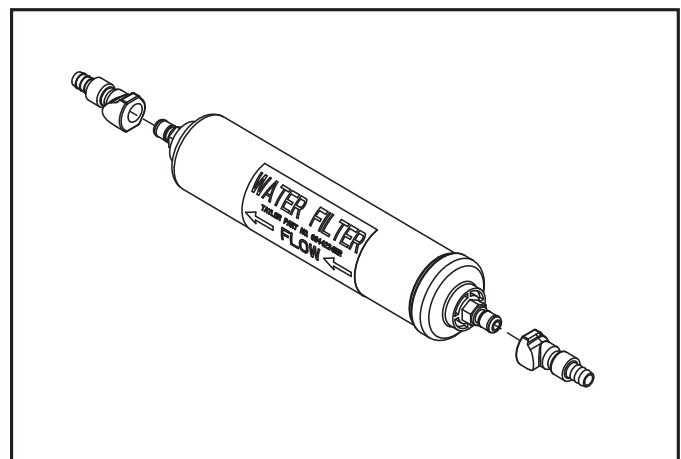

Figure 1-1

Electrical Connections

Each freezer requires one power supply. Check the data label on the freezer for branch circuit over current protection or fuse, circuit amp capacity, and electrical specifications. See the wiring diagram provided inside of the control box for proper power connections.

In the United States, this equipment is intended to be installed in accordance with the National Electrical Code (NEC), ANSI/NFPA 70-1987. In all other areas of the world, equipment should be installed in accordance with the existing local codes. Please contact your local authorities.

The purpose of the NEC code is the practical safeguarding of persons and property from hazards arising from the use of electricity. This code contains provisions considered necessary for safety. Compliance therewith and proper maintenance will result in an installation essentially free from hazard.

The NEC is a United States regulatory agency. International users must follow local electrical codes.



CAUTION! This equipment must be properly grounded! Failure to do so can result in severe personal injury from electrical shock!



WARNING! DO NOT operate this freezer with larger fuses than specified on the unit data label. Failure to follow this instruction may result in electrocution or damage to the machine.



IMPORTANT! This unit is provided with an equipotential grounding lug that is to be properly attached to the rear of the frame by the authorized installer. The installation location is marked by the equipotential bonding symbol (5021 of IEC 60417- 1) on the removable panel and the frame.



NOTICE!

- Stationary machines which are not equipped with a power cord and a plug or another device to disconnect the machine from the power source must have an all-pole disconnecting device with a contact gap of at least 0.125 in. (3 mm) installed in the external installation.
- Machines that are permanently connected to fixed wiring and for which leakage currents may exceed 10 mA, particularly when disconnected or not used for long periods, or during initial installation, shall have protective devices to protect against the leakage of current, such as a GFI, installed by the authorized personnel to the local codes.
- Supply cords used with this unit shall be oil-resistant, sheathed flexible cable not lighter than ordinary polychloroprene or other equivalent synthetic elastomer-sheathed cord (code designation 60245 IEC 57) installed with the proper cord anchorage to relieve conductors from strain, including twisting, at the terminals and protect the insulation of the conductors from abrasion.
- If the supply cord is damaged, it must be replaced by the manufacturer, service agent, or a similarly qualified person, in order to avoid a hazard.

Beater Rotation



NOTICE! Beater rotation must be clockwise as viewed looking into the freezing cylinder.

Note: The following repairs must be performed by an authorized Taylor service technician.

To correct rotation on a single-phase unit, change the leads on the capacitor in the watt-control electrical box. (See the wiring diagram for details.)

To correct the rotation on a three-phase unit, interchange any two incoming power supply lines at the freezer main terminal block only.

Initial Freezing Cylinder Cleaning

Due to the types of products used in FCB equipment, it is imperative that the freezing cylinder and the inlet tube be thoroughly brush cleaned, rinsed, and sanitized before running any product.

1 Prepare a cleaning solution, using 2 oz. of liquid detergent in 2 gal (7.6 L) of warm water. Using this solution, brush clean the freezing cylinder and the inlet tube. Rinse the freezing cylinder and the inlet tube with clean water. Use the sanitizing procedures outlined in this Operator Manual, starting on page 6-5.

Refrigerant



CAUTION! This machine contains fluorinated greenhouse gases (F-Gas) to provide refrigeration using a hermetically sealed circuit or within foam insulation. This machine's type of gas, quantity, Global Warming Potential (GWP), and CO₂ tonnes equivalent information is recorded on the unit's data-label. The refrigerant used is generally considered non-toxic and non-flammable. However any gas under pressure is potentially hazardous and must be handled with caution.

NEVER fill any refrigerant cylinder completely with liquid. Filling the cylinder to approximately 80% will allow for normal expansion.



CAUTION! Use only approved refrigerant listed on the machine's data-label or authorized through a manufacturer's technical bulletin. The use of any other refrigerant may expose users and operators to unexpected safety hazards.



WARNING! Refrigerant liquid sprayed onto the skin may cause serious damage to tissue. Keep eyes and skin protected. If refrigerant burns should occur, flush immediately with cold water. If burns are severe, apply ice packs and contact a physician immediately.



WARNING! Refrigerant liquid sprayed onto the skin may cause serious damage to tissue. Keep eyes and skin protected. If refrigerant burns should occur, flush immediately with cold water. If burns are severe, apply ice packs and contact a physician immediately.



IMPORTANT! Taylor reminds technicians to be aware of government laws regarding refrigerant recovery, recycling, and reclaiming systems. If you have any questions regarding these laws, please contact the factory service department.



IMPORTANT! Refrigerants and their associated lubricants may be extremely moisture absorbent. When opening a refrigeration system, the maximum time the system is open must not exceed 15 minutes. Cap all open tubing to prevent humid air or water from being absorbed by the oil.

The freezer you have purchased has been carefully engineered and manufactured to give you dependable operation.

When properly operated and cared for, your freezer will produce a consistent quality product. Like all mechanical products, this machine will require cleaning and scheduled maintenance. A minimum amount of care and attention is necessary if the operating procedures outlined in this manual are followed closely.



IMPORTANT! This manual should be read before operating or performing any maintenance on your equipment.

Your freezer will not eventually compensate and correct for any errors during the setup or filling operations. Thus, the initial assembly and priming procedures are of extreme importance. It is strongly recommended that all personnel responsible for the equipment's operation study these procedures together in order to be properly trained and to make sure that no misunderstandings exist.

If you require technical assistance, please contact your local authorized Taylor distributor for service.

Note: Your Taylor warranty is valid only if the parts are authorized Taylor parts, purchased from the local authorized Taylor distributor, and only if all required service work is provided by an authorized Taylor service technician. Taylor reserves the right to deny warranty claims on units or parts if non-Taylor-approved parts or incorrect refrigerant were installed in the unit, system modifications were performed beyond factory recommendations, or it is determined that the failure was caused by abuse, misuse, neglect, or failure to follow all operating instructions. For full details of your Taylor warranty, please see the Limited Warranty section in this manual.



IMPORTANT! If the crossed-out waste container symbol is affixed to this product, it signifies that this product is compliant with the EU Directive as well as other similar legislation in effect after August 13, 2005. Therefore, it must be collected separately after its use is completed, and cannot be disposed as unsorted municipal waste.

The user is responsible for returning the product to the appropriate collection facility, as specified by your local code.

For additional information regarding applicable local laws, please contact the municipal facility and/or local distributor.

Compressor Warranty Disclaimer

The refrigeration compressor(s) on this unit are warranted for the term stated in the Limited Warranty section in this manual. However, due to the Montreal Protocol and the U.S. Clean Air Act Amendments of 1990, many new refrigerants are being tested and developed, thus seeking their way into the service industry. Some of these new refrigerants are being advertised as drop-in replacements for numerous applications. It should be noted that in the event of ordinary service to this unit's refrigeration system, **only the refrigerant specified on the affixed data label should be used.** The unauthorized use of alternate refrigerants will void your Taylor compressor warranty. It is the unit owner's responsibility to make this fact known to any technician he employs.

It should also be noted that Taylor does not warrant the refrigerant used in its equipment. For example, if the refrigerant is lost during the course of ordinary service to this unit, Taylor has no obligation to either supply or provide replacement refrigerant either at billable or unbillable terms. Taylor will recommend a suitable replacement if the original refrigerant is banned, obsoleted, or no longer available during the five (5) year Taylor warranty of the compressor.

From time to time Taylor may test new refrigerant alternates. Should a new refrigerant alternate prove through Taylor's testing that it would be accepted as a drop-in replacement for this unit, the disclaimer in this "Compressor Warranty Disclaimer" section will not apply to the use of the alternate refrigerant approved by Taylor.

To find out the current status of an alternate refrigerant as it relates to your compressor warranty, call Taylor or your local authorized Taylor distributor. Be prepared to provide the model/serial number of the unit in question.

Note: *Continuing research results in steady improvements; therefore, information in this Operator's Manual is subject to change without notice.*

We at Taylor Company are concerned about the safety of the operator when he or she comes in contact with the freezer and its parts. Taylor has gone to extreme efforts to design and manufacture built-in safety features to protect both you and the service technician. As an example, warning labels have been attached to the freezer to further point out safety precautions to the operator.



IMPORTANT! Failure to adhere to the following safety precautions may result in severe personal injury. Failure to comply with these warnings may damage the machine and its components. Component damage will result in part replacement expense and service repair expense test.



NOTICE! DO NOT operate the freezer without reading the Operator's Manual. Failure to follow this instruction may result in equipment damage, poor freezer performance, health hazards, or personal injury.



IMPORTANT! This machine is to be used only by trained personnel. It is not intended for use by children or people with reduced physical, sensory, or mental capabilities, or lack of experience and knowledge, unless given supervision or instruction concerning the use of the machine by a person responsible for their safety. Children should be supervised to ensure that they do not play with the appliance.



IMPORTANT! This unit is provided with an equipotential grounding lug that is to be properly attached to the rear of the frame by the authorized

installer. The installation location is marked by the equipotential bonding symbol (5021 of IEC 60417- 1) on the removable panel and the frame.



WARNING! DO NOT use a water jet to clean or rinse the freezer. Failure to follow these instructions may result in serious electrical shock.



WARNING! Avoid injury.

- **DO NOT** operate the freezer unless it is properly grounded.
- **DO NOT** operate freezer with larger fuses than specified on the data label.
- All repairs must be performed by an authorized Taylor service technician.
- The main power supplies to machine must be disconnected prior to performing repairs.
- **For Cord-Connected Units:** Only authorized Taylor service technicians or licensed electricians may install a plug or replacement cord on the unit.
- Stationary machines which are not equipped with a power cord and a plug or another device to disconnect the machine from the power source must have an all-pole disconnecting device with a contact gap of at least 0.125 in. (3 mm) installed in the external installation.
- Machines that are permanently connected to fixed wiring and for which leakage currents may exceed 10 mA, particularly when disconnected or not used for long periods, or during initial installation, shall have protective devices to protect against the leakage of current, such as a GFI, installed by the authorized personnel to the local codes.
- Supply cords used with this unit shall be oil-resistant, sheathed flexible cable not lighter

than ordinary polychloroprene or other equivalent synthetic elastomer-sheathed cord (code designation 60245 IEC 57) installed with the proper cord anchorage to relieve conductors from strain, including twisting, at the terminals and protect the insulation of the conductors from abrasion.

- If the supply cord is damaged, it must be replaced by the manufacturer, service agent, or a similarly qualified person, in order to avoid a hazard.

Failure to follow these instructions may result in electrocution. Contact your local authorized Taylor distributor for service.

3



WARNING! Avoid injury.

- **DO NOT** allow untrained personnel to operate this machine.
- **DO NOT** put objects or fingers in door spout.
- **DO NOT** operate the freezer unless all service panels and access doors are fastened with screws.
- **DO NOT** remove the freezer door or beater assembly unless the control switches are in the OFF position.

Failure to follow these instructions may result in severe personal injury from hazardous moving parts.



This unit has many sharp edges that can cause severe injuries.

- **DO NOT** put objects or fingers in the door spout. This may contaminate the product and cause severe personal injury from blade contact.
- **USE EXTREME CAUTION** when removing the beater assembly. The scraper blades are very sharp.



WARNING! This unit is pressurized when in operation.

- The control switch must be in the OFF position until the unit is completely assembled.
- No part should ever be removed from the machine while it is in operation.
- No parts should be removed until the control switch has been turned to the OFF position and all pressure has been relieved by opening the draw valve.

Failure to follow this instruction may result in severe personal injury from hazardous moving parts or from the impact of propelled parts.



IMPORTANT! Access to the service area of the unit is restricted to persons having knowledge and practical experience with the appliance, in particular as far as safety and hygiene are concerned.



CAUTION! This unit must be installed on a level surface to avoid the hazard of tipping. Extreme care should be taken in moving this equipment for any reason. Two or more persons are required to safely move this unit. Failure to comply may result in personal injury or equipment damage.



NOTICE! Cleaning and sanitizing schedules are governed by your federal, state, or local regulatory agencies and must be followed accordingly. Please see the cleaning section of this manual for the proper procedure to clean this unit.



CAUTION! This machine is designed to

maintain product temperature under 41°F (5°C). Any product being added to this machine must be below 41°F (5°C). Failure to follow this instruction may result in health hazards and poor freezer performance.

Do not obstruct air intake and discharge openings.

Air-cooled units require a minimum of 3 in. (76 mm) of airspace on both sides, 3 in. (76 mm) at the rear, and 12 in. (305 mm) on the top of the unit. Minimum air clearances must be met to ensure adequate airflow for optimum performance.

For indoor Use Only: This unit is designed to operate indoors, under normal ambient temperatures of 70°F to 75°F (21°C to 24°C). The freezer has successfully performed in high ambient temperatures of 104°F (40°C) at reduced capacities.

Do not run the machine without product. Failure to follow this instruction can result in damage to the machine.

Noise Level: Airborne noise emission does not exceed 78 dB(A) when measured at a distance of 3.3 ft. (1.0 m) from the surface of the machine and at a height of 5.25 ft (1.6 m) from the floor.



WARNING! Asphyxiation Hazard!

If used with CO₂ (Carbon Dioxide) or N₂ (Nitrogen), always make sure the area is well ventilated. Vent exhaust gas to outside atmosphere using a hose. Failure to do so can cause serious injury.

C303

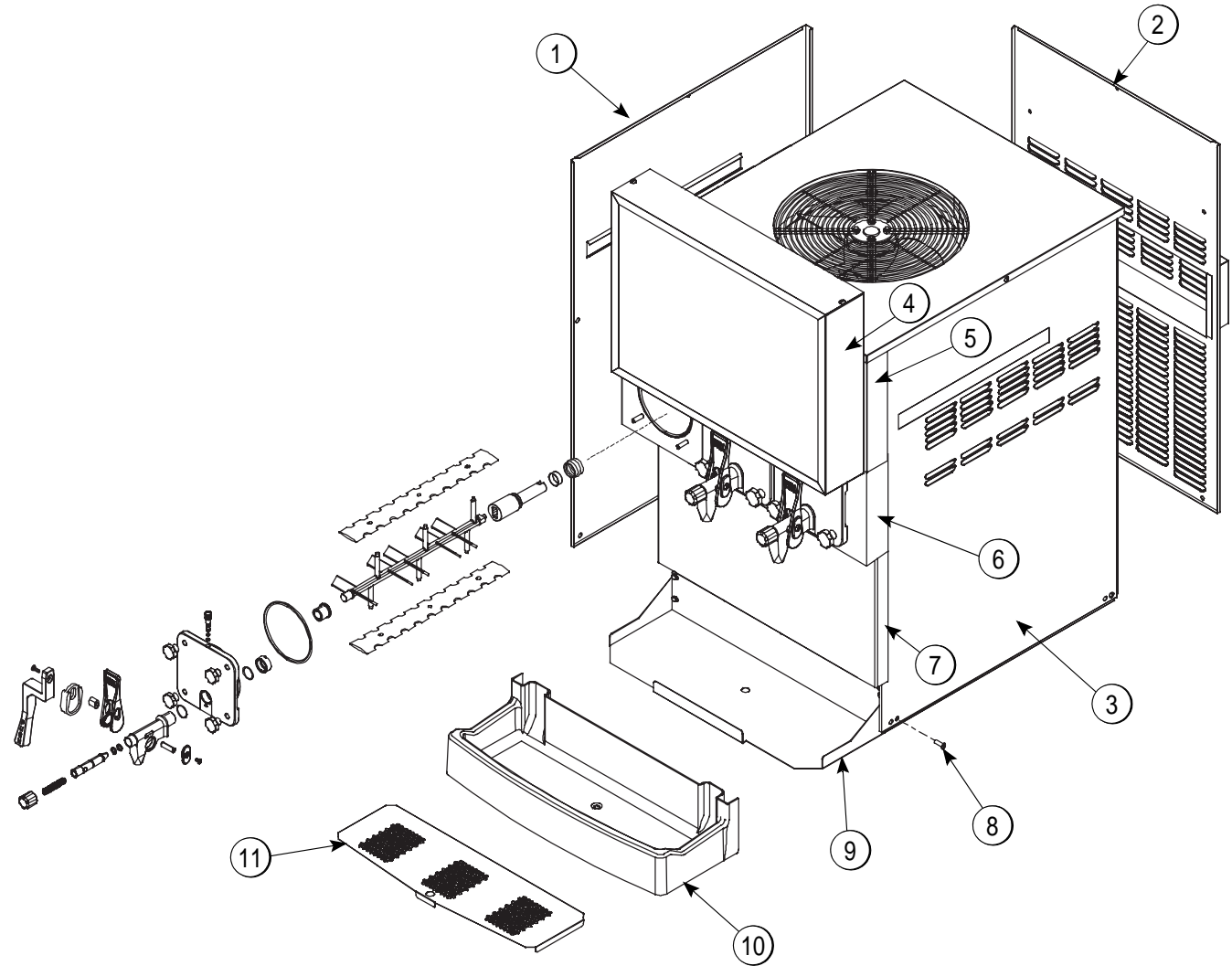

Figure 4-1

Item	Description	Part No.
1	Panel-Side Left	059721
2	Panel A.-Rear	X66671
3	Panel-Side Right	059722
4	Display-LED *C303 P.O.P.	066670
5	Panel-Front-Upper	066682
6	Panel-Front-Shell	66647

Item	Description	Part No.
7	Panel-Front-Lower	066678
8	Screw-10-32 X 1/2 SLTD TRUS	037734
9	Shelf-Tray-Drip	066677
10	Tray-Drip	066676
11	Shield-Splash	066680

Model C314

4

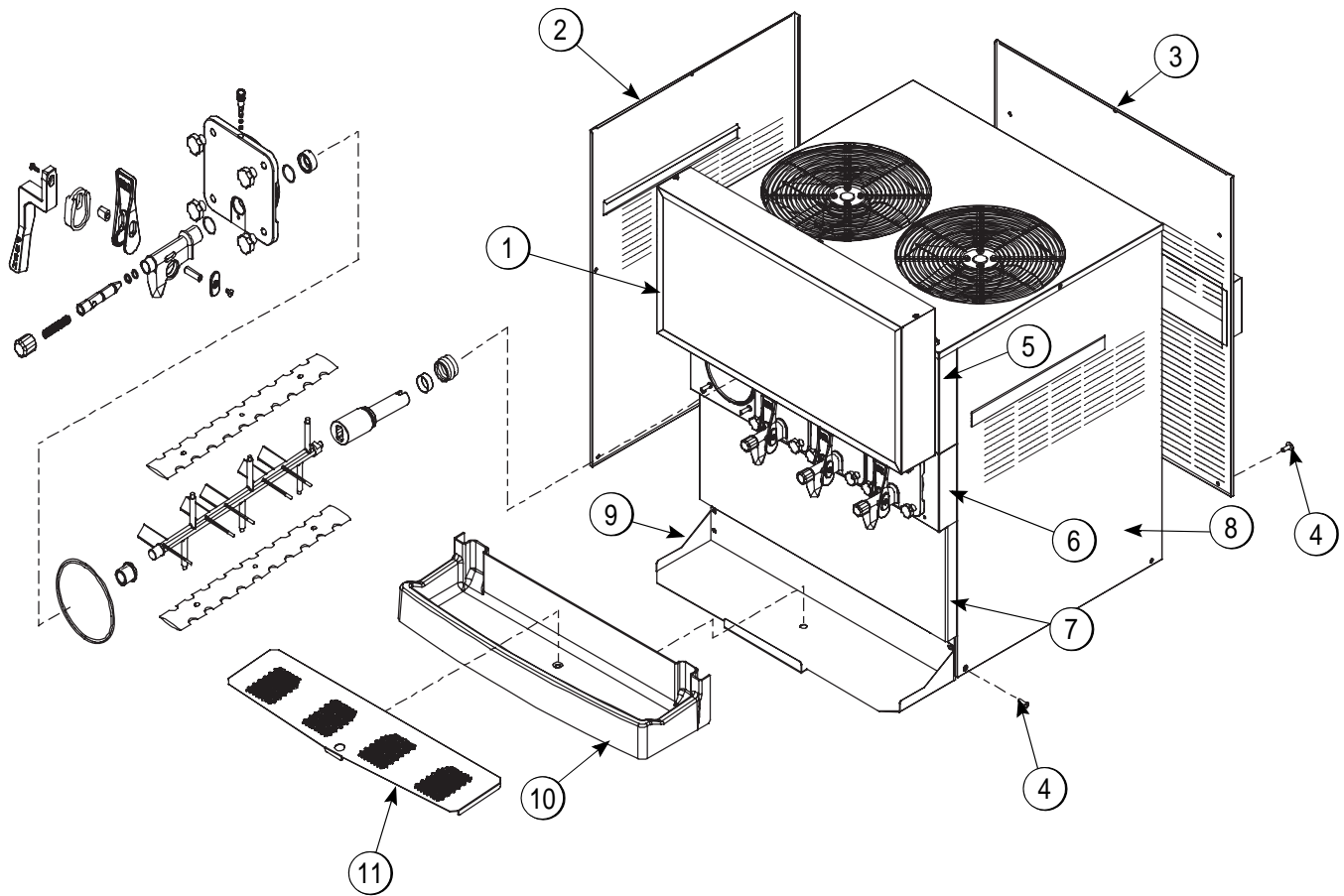

Figure 4-2

Item	Description	Part No.
1	Display-LED-15.4" Tall	68575
2	Panel-Side-Left	59721
3	Panel A.-Rear	X68182
4	Screw-10-32X1/2 SLTD TRUS	37734
5	Panel-Front-Upper	68496
6	Panel-Front-Shell	059576-SPN

Item	Description	Part No.
7	Panel-Front-Lower	59652
8	Panel-Side-Right	59722
9	Shelf-Tray-Drip	59653
10	Tray-Drip	59654
11	Shield-Splash	59659

Beater Door Assembly

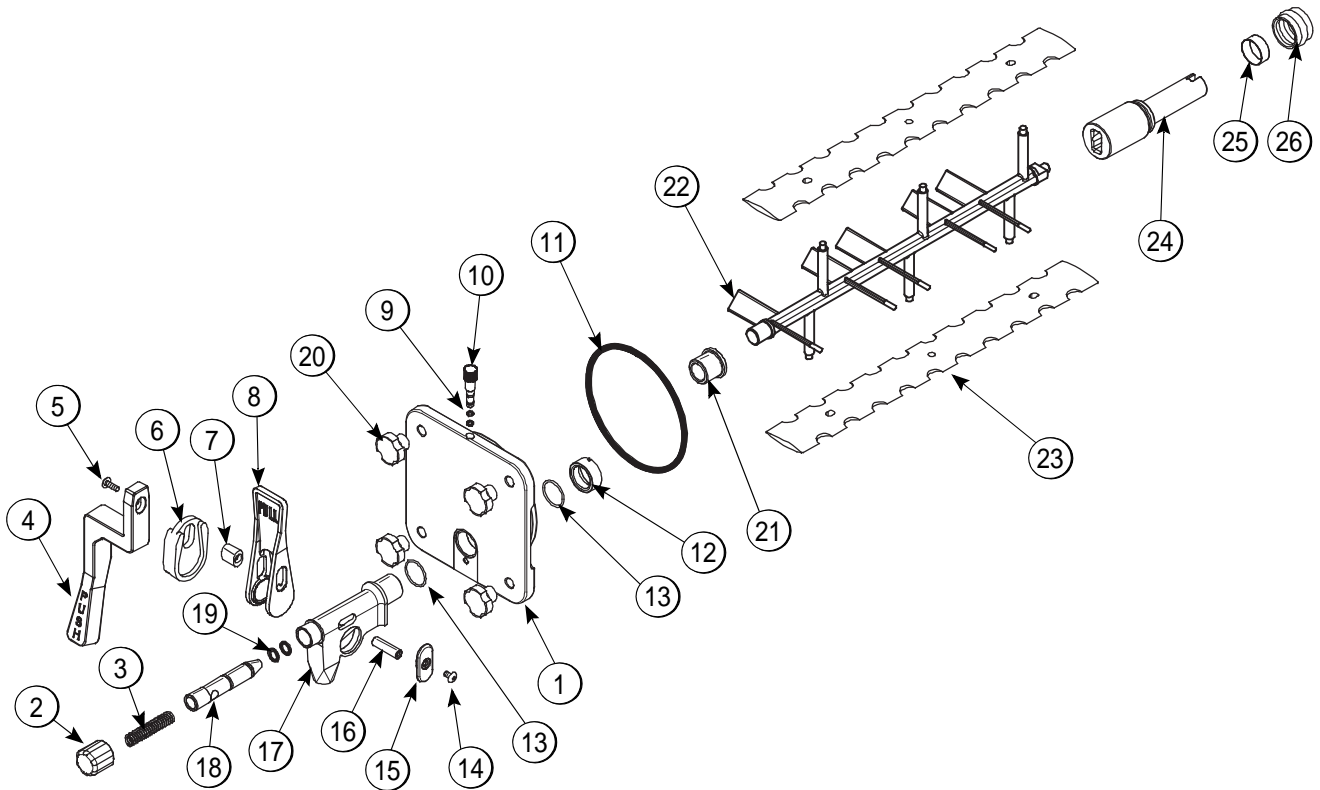

Figure 4-3

Item	Description	Part No.
1	Door A.-Freezer-Slush	X80599
2	Cap-Spout-Door-FCB-BLK	046191-BLA
3	Spring-Comp.480X.072X3.0	039320
4	Handle-ADA-FCB	068580
5	Screw-10/32X1" PHIL TRUSS	016369
6	Adaptor-Mounting-AD	046190-BLA
7	Pin-Handle-ADA-FCB	046192-BLA
8	Handle-Draw-FCB-Black	039321
9	O-ring-9/32 OD X 1/16 Wall	046193-BLA
10	Plug-Prime-Slush-Press	053869
11	O-ring-5-1/40.D. X .210W	029751
12	Nut-Spout-Door-Slush	039568
13	O-ring-1.129 ODX.989IDX.070	039219
14	Screw-10-32X3/8 Phil Truss	053869

Item	Description	Part No.
15	Slide-Handle-Door-FCB	046193-BLA
16	Pin-Pivot-Spout-Door	039321
17	Spout-Door-FCB-Black	046190-BLA
18	Valve-Draw-Door-Slush	039324
19	O-ring-9/16 OD X .103W	016369
20	Nut-Stud *345-346-349-355*	043666
21	Bearing-Front-Slush	039349
22	Beater-Plastic-FCB-Press	041182
23	Blade-Scraper-FCB 16L	041103
24	Shaft-Beater-Slush- Pocket	083143
25	Bushing-Beater Shaft/Boot Seal	042278
26	Seal-Drive Shaft	032560

Accessories

4

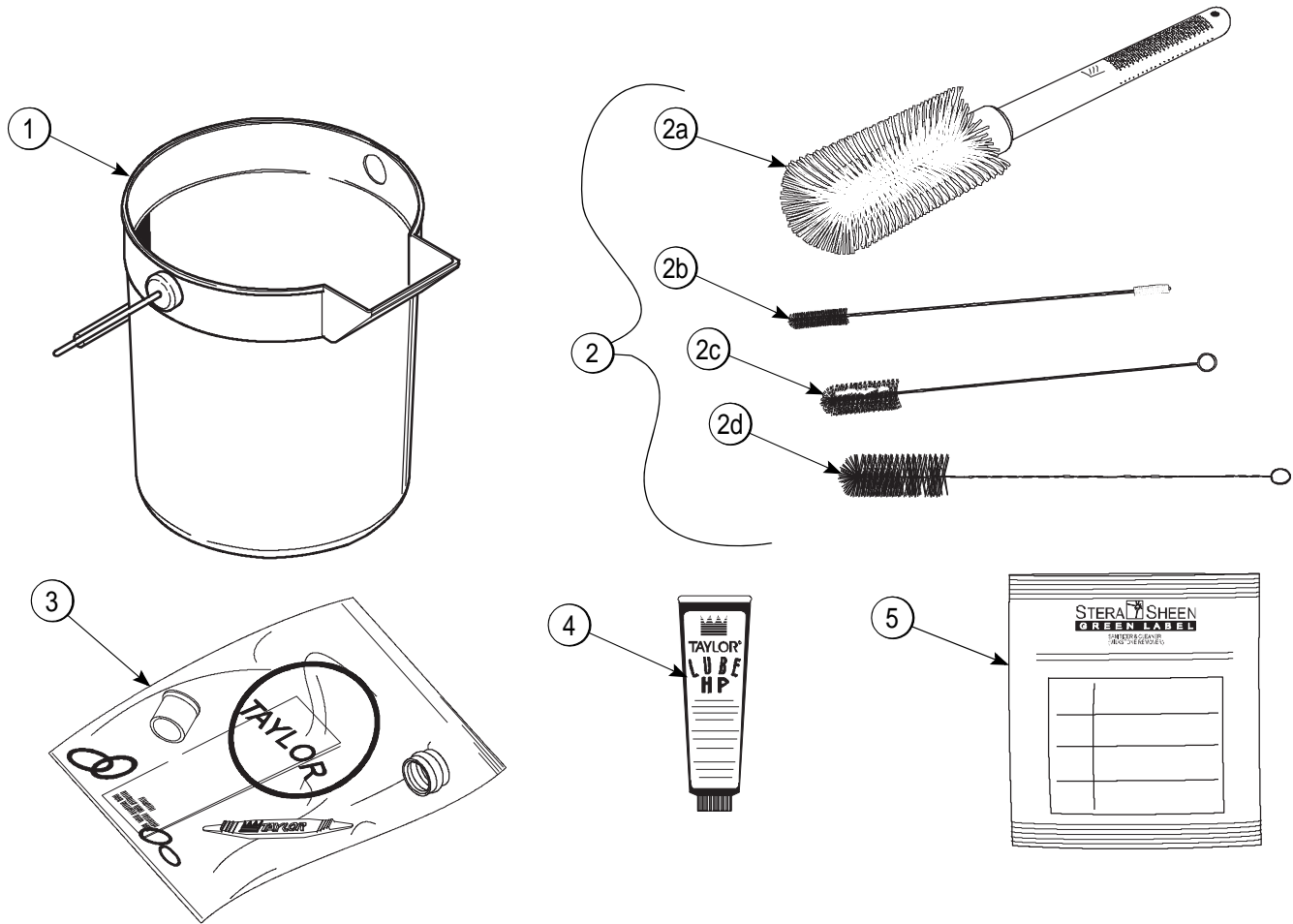

Figure 4-4

Item	Description	Part No.
1	Pail-Mix 10 qt	013163
2	Brush A.-Package	X64275
2a	Brush-Mix Pump Body-3" X 7"	023316
2b	Brush-DBL End	013072
2c	Brush-Rear BRG 1"D X 2"LG X 14	013071

Item	Description	Part No.
2d	Brush-Draw Valve 1-1/2"OD X 3"	014753
3	Kit A.-Tune Up	X59121
4	Lubricant-Taylor Hi PERF	048232
*5	Sanitizer-Stera Sheen	See Note

*Not Shown – A sample container of sanitizer is sent with the unit. For reorders, order Stera Sheen part no. 055492 (100 2 oz. packs) or Kay-5 part no. 041082 (200 packs).

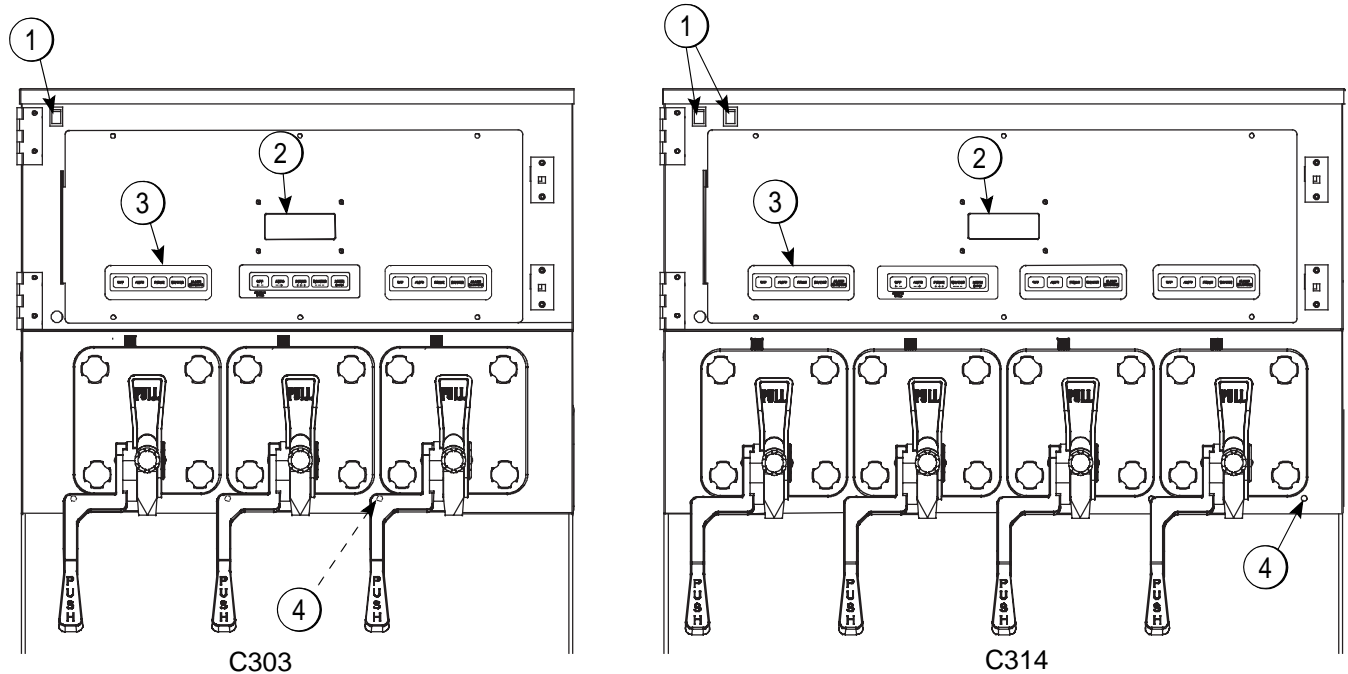

Figure 5-1

Item	Description
1	Control Switch
2	Liquid Crystal Display
3	Keypad
4	Product Light

To identify the freezing cylinders in these units, the barrels are referred to as follows, starting from left to right:

- Barrel 1
- Barrel 2
- Barrel 3
- Barrel 4 (C314 only)

Control Switch

The control switch(s) is located at the top left corner of the upper front panel, behind the illuminated display. When placed in the ON position, this control switch allows machine operation.

Liquid Crystal Display

There is one Liquid Crystal Display (LCD) located on the upper front panel behind the illuminated display.

The LCD shows the current operating mode of the freezing cylinders. It also indicates whether there is enough syrup, CO₂, and water being supplied to the freezer. If an error in the machine operation occurs, a warning tone will sound and the word FAULT will flash on the third line of the display.

Operational Mode Displays

Note: The screens illustrated in this section are those seen on the Model C303.

(The Model C314 screens vary slightly to include the fourth barrel information.)

These screens illustrate the operational mode information displayed during normal operation. The LCD displays information corresponding to the freezing cylinders located directly beneath them.

When the unit is plugged into the wall receptacle and the control switch is in the ON position, this screen appears.

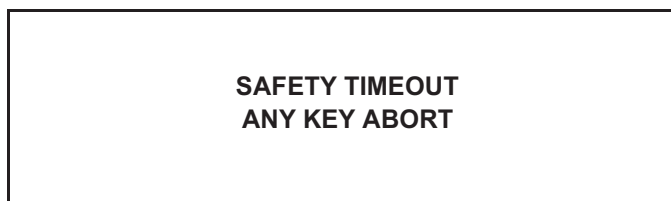

This display will remain on the LCD for 60 seconds unless a key is pressed. If any key is pressed (or 60 seconds pass), the next screen appears.

5

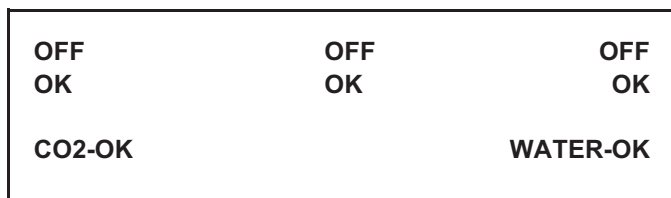

Note: Syrup, CO₂ and water are satisfied.

Pressing the AUTO (- ->) keys for each freezing cylinder will display this screen.

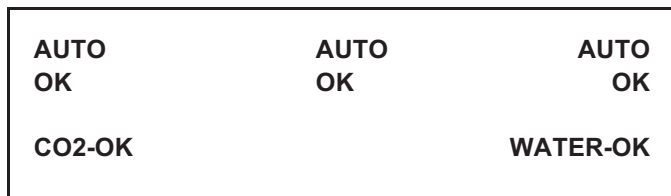

Line 1 indicates the operating mode for each freezing cylinder.

Line 2 indicates the status of the syrup systems in each freezing cylinder. As long as syrup is available, the word OK will appear on the LCD. When the syrup supply is insufficient, the word OUT will flash on the LCD. The same rules apply to the fourth line, which indicates the status of CO₂ and H₂O.

The third line of this display is a fault indicator. If an error in machine operation occurs, the word FAULT will be displayed on the LCD. See the example screen below.

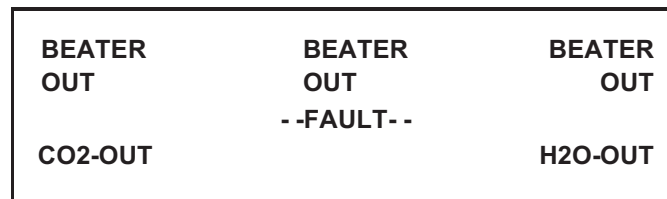

Note: Repeat all information and programming procedures for each individual control from the left to the right.

Operator Menu Display

The OPERATOR MENU is used to enter the operating screens. To access the OPERATOR MENU, press the MENU SELECT key. The cursor will flash under the letter "A", indicating that this is screen A. To select a different screen, use the AUTO (- ->) and OFF (<- -) keys to move the cursor to the desired screen selection and press the MENU SELECT key.



Beater Recovery Display

The Beater Recovery screen only displays when the unit is in the Beater Recovery mode. If the screen information for the barrel in the Beater Recovery mode is flashing, it means the barrel is awaiting Defrost. If it is not flashing, the barrel is in the Beater Recovery mode. The following screen shows barrel 2 in the Beater Recovery mode.

AUTO OK	DEFR OK	AUTO OK
CO2-OK		WATER-OK

Operator Menu Timeout

If the display is left in the operator menu or in any of the operator menu selections except "Current Conditions," the display will return to the system mode screen 60 seconds after the last key press.

The Current Conditions screen will be displayed until manually changed.

Finding Current Fault Conditions

Faults, when corrected, are cleared from the fault description screen, with the following exception: BRL NOT COOLING. This fault requires the operator to press the OFF (<-) key (when in the FAULT DESCRIPTION screen) to clear the fault message and the warning tone.

To see if there is more than one fault in either freezing cylinder, press the PRIME (+++) key. To return to the OPERATOR MENU, press the MENU SELECT key once. To return to the Main Screen, use the AUTO (->) key to cycle to MENU ITEM A, then press the MENU SELECT key.

Screen B is FAULT DESCRIPTION. The fault description screen will indicate if there is a fault in one of the freezing cylinders. Upon correction of the fault, the warning tone will stop.

Table 5-1

Fault Messages	
Beater Overload	Beater is out on overload.
Chk Refrig Sys Psi	Out on compressor high pressure cut-out.
Thermistor Short	Shorted thermistor probe.
Thermistor Open	Open thermistor probe.
H ₂ O Pressure Low	Water pressure is low.
CO ₂ Pressure Low	CO ₂ pressure is low.
Syrup Pressure Low	Syrup is no longer present.
BRL Temp 2 High	Freezing cylinder temperature is above 120°F (49°C).
BRL Not Cooling	Freezing cylinder is not cooling after 5-minutes.
No Fault Found	No fault conditions are apparent.

The following are explanations of possible faults and the display screens. Pressing the +++ key shows the faults for each freezing cylinder. The freezing cylinders are referred to as barrel 1 (left barrel), barrel 2 (center barrel), and barrel 3 (right barrel).

NO FAULT FOUND

No fault conditions are apparent.

FAULT DESCRIPTION		
BARREL 1		
NO FAULT FOUND		
CLR	+++	SEL

BEATER OVERLOAD

Beater motor is out on overload. When this fault occurs, the affected barrel automatically turns off. The fault clears when the condition is corrected.

FAULT DESCRIPTION		
BARREL 1		
BEATER OVERLOAD		
CLR	+++	SEL

USER INTERFACE

CHK REFRIG SYS PSI

The compressor is out on high head pressure. When this fault occurs, the machine automatically turns off. The fault clears when the condition is corrected.

FAULT DESCRIPTION
BARREL 1
CHK REFRIG SYS PSI

CLR **+++** **SEL**

THERMISTOR SHORT

One of the barrel (freezing cylinder) thermistor probes is faulty.

FAULT DESCRIPTION
BARREL 1
THERMISTOR SHORT

CLR **+++** **SEL**

THERMISTOR OPEN

One of the barrel (freezing cylinder) thermistor probes is faulty.

FAULT DESCRIPTION
BARREL 1
THERMISTOR OPEN

CLR **+++** **SEL**

SYRUP PRESS LOW

When the syrup out indicator displays a lack of syrup, the barrel enters the Hold mode. No refrigeration or product flow from the flow control is allowed. The beater will operate as long as the barrel temperature is below 50°F (10°C). (See Syrup Out Indicator on page 5-9.)

FAULT DESCRIPTION
BARREL 1
SYRUP PRESS LOW

CLR **+++** **SEL**

CO₂ PRESSURE LOW—

When the CO₂ out indicator displays a lack of CO₂, a 60-second internal timer will start. If the CO₂ is not replenished at the end of the 60 seconds, both freezing cylinders will shut down and this fault message will appear. Replenish the CO₂, and the fault message and warning tone will clear.

FAULT DESCRIPTION
BARREL 1
CO2 PRESSURE LOW

CLR **+++** **SEL**

H₂O PRESSURE LOW

When the water out indicator displays a lack of water, a 60-second internal timer will start. If the water is not replenished at the end of the 60 seconds, all freezing cylinders will shut down and this fault message will appear. Replenish the water and the fault message and warning tone will clear.

FAULT DESCRIPTION
BARREL 1
H2O PRESSURE LOW

CLR **+++** **SEL**

BRL NOT COOLING

A freezing cylinder check has been established for the Auto mode of operation. If a freezing cylinder enters the Auto mode, the control will check product temperature. After 5-minutes, it will again check product temperature. If product temperature does not drop in that 5-minute span, the freezing cylinder will shut down and this message will appear on the fault screen. For this check to be valid, the product temperature must be above 40°F (4.4°C).

FAULT DESCRIPTION
BARREL 1
BARREL NOT COOLING

CLR **+++** **SEL**

BRL TEMP 2 HIGH

A maximum allowable product temperature has been established to prevent product from excessive heating. If the product exceeds 120°F (49°C) for any reason (in any mode of operation), the entire unit shuts down.

FAULT DESCRIPTION		
BARREL 1		
BARREL TEMP 2 HIGH		
CLR	+++	SEL

BEATER OVER CURRENT

When the unit experiences a Beater Over Current fault, one of the following two events will occur.

- If the barrel temperature is above 40°F (4.4°C) the software will generate a Beater Overload fault, i.e. the overload is not the result of a frozen barrel. The fault will be placed in the Fault History, and the barrel will be placed into the OFF mode. Pressing the AUTO key will clear the fault and attempt to operate the barrel in the Auto mode. The fault may also be cleared in the Fault Description menu. If the overload still exists, another Beater Overload fault will be generated.
- If the barrel temperature is at or below 40°F (4.4°C) the software will enter the Beater Overload Recovery process, i.e., the overload may be the result of a frozen barrel.

Beater Overload Recovery Process

The barrel will be placed in the DEFROST PENDING mode. This is indicated as a flashing "DEF" mode on the display. If the opposing barrel is refrigerating or defrosting, the barrel in recovery will remain in the DEFROST PENDING mode. If the opposing barrel is not refrigerating and is not defrosting, the barrel in recovery will switch from DEFROST PENDING mode into the DEFROST mode.

Once the recovery barrel is in the DEFROST mode, the barrel will begin heating, but the software will not attempt to run the beater for 10-minutes. This gives the beater motor time to cool down from its internal overload. If the barrel reaches 50°F (10°C) before the 10-minute cooling time expires, the software will stop heating the barrel. If the barrel temperature falls to 35°F (1.7°C), heating will resume.

When the barrel temperature exceeds 40°F (4.4°C) and the 10-minute cooling time has expired, the software will attempt to run the beater.

If the current sensor senses current flowing through the beater motor, the software will wait for 30 seconds (even if the barrel temperature has reached 50°F/10°C) in case the barrel temperature falls due to the beater stirring the product. After the 30 seconds, the DEFROST mode operation will continue until the barrel temperature reaches 50°F (10°C), at which time it will switch to the Auto mode and resume normal operation.

Note: If the beater fails to start, or if another internal overload occurs, the recovery process will be repeated from the beginning. If a third internal overload occurs, a Beater Overload fault will be generated, and the barrel will be placed into the Off mode.

SET CLOCK.

Use the AUTO (- ->) and OFF (<- -) keys to place the cursor under the element to be set (hour, minute, month, day, or year). Use the PRIME (+++) and BEATER (- - -) keys to increase or decrease the time/date settings.

Note: The clock is programmed with military time.

SET CLOCK		
<u>14:30</u>		7/25/10
<- - -> +++	- - -	SEL

If an invalid date is entered, (example: if the date entered exceeds the days of the month) the LCD will display the following screen.

SET CLOCK		
<u>14:30</u>		7/25/10
	INVALID DATE	SEL

USER INTERFACE

Pressing the MENU SELECT key will return to the previous screen to allow correction of the calendar entry.

Once a valid date is entered, pressing the MENU SELECT key will display the Daylight Saving Time screen. The cursor will initially appear under the selection that is currently in use.

DAYLIGHT SAVING TIME	
<u>ENABLE</u>	DISABLE
<- - ->	SEL

Press the AUTO (- ->) and OFF (<- -) keys to move the cursor under the desired option. Pressing the MENU SELECT key with the cursor under "DISABLE" will disable the selection and return to the Operator Menu.

Pressing the MENU SELECT key with the cursor under "ENABLE" accepts the selection and displays a screen similar to the following. This screen will initially show the setting that is currently in use.

DST START	
<u>MAR</u>	Second Sunday
<- - - -> + + +	- - - SEL

Pressing the AUTO (- ->) and OFF (<- -) keys moves the cursor right or left. Pressing the PRIME (+++) and BEATER (- - -) keys increases or decreases the selected month when the cursor is under the month. Pressing the PRIME (+++) and BEATER (- - -) keys increases or decreases the selected Sunday when the cursor is under the day.

Pressing the MENU SELECT key accepts the selection and displays a screen similar to the following. This screen will initially show the setting that is currently in use.

DST END	
<u>JAN</u>	First Sunday
<- - - -> + + +	- - - SEL

Pressing the AUTO (- ->) and OFF (<- -) keys moves the cursor right or left. Pressing the PRIME (+++) and BEATER (- - -) keys increases or decreases the selected month when the cursor is under the month. Pressing the PRIME (+++) and BEATER (- - -) keys increases or decreases the selected Sunday when the cursor is under the day. Pressing the MENU SELECT key accepts the selection and returns to the Operator Menu.

MANUAL DEFROST

This screen allows the operator to manually defrost the freezing cylinders.

To defrost the freezing cylinders, place the cursor under the barrel number and press the MENU SELECT key.

MANUAL DEFROST	
BARREL	<u>1</u> 2 3
<- - ->	EXIT
	SEL

Move the cursor to "YES". Press the MENU SELECT key and the command will be executed.

MANUAL DEFROST	
<u>YES</u>	NO
<- - ->	EXIT
	SEL

Note: Only one freezing cylinder may be placed in the DEFROST mode at a given time. Attempting to place more than one freezing cylinder into DEFROST will result in the following screen:

ALREADY IN DEFROST

Press the MENU SELECT key to return the unit to the operator menu.

SYSTEM INFORMATION

It consists of six display features.

The first feature indicates the software version.

```

SYSTEM INFORMATION
C300 CONTROL UVC2
VERSION 1.00
SEL
    
```

The second feature indicates the bill of material number and the serial number.

It also indicates if the unit is equipped with a water pressure switch.

```

B.O.M. C30227C000
S/N K0000000
WITH H20 PRESS SW
SEL
    
```

The third feature indicates the version number of the language and text.

```

SYSTEM INFORMATION
LANGUAGE
VERSION 1.09      ENGLISH 446
SEL
    
```

The fourth feature will display the **Power Saver mode, OFF, REST, or STANDBY** status.

If the Power Saver Mode is OFF, the following screen will be displayed.

```

POWER SAVER MODE
OFF
SEL
    
```

If a Power Saver mode is programmed, one of the following screens will appear.

```

POWER SAVER REST
CYCLE 1      SUN      01:00
              SUN      08:30
              + + +      - - -      SEL
    
```

```

POWER SAVER STANDBY
CYCLE 1      SUN      01:00
              SUN      08:30
              + + +      - - -      SEL
    
```

USER INTERFACE

The fifth feature will indicate the defrost time and which day(s) the defrost will occur.

DEFROST TIME BARREL 1			
CYCLE <u>1</u>	ALL		09:00
	+++	---	SEL

DEFROST TIME BARREL 1			
CYCLE <u>1</u>	SUN		09:00
<---->	+++	---	SEL

DEFROST TIME BARREL 2			
CYCLE <u>1</u>	ALL		10:00
	+++	---	SEL

DEFROST TIME BARREL 2			
CYCLE <u>1</u>	SUN		10:00
<- - ->	+++	---	SEL

DEFROST TIME BARREL 3			
CYCLE <u>1</u>	ALL		10:00
	+++	---	SEL

DEFROST TIME BARREL 3			
CYCLE <u>1</u>	SUN		10:00
<- - ->	+++	---	SEL

There are 8 possible settings (cycles) per weekday. The settings may overlap.

Press the MENU SELECT key to return to the operator menu.

CURRENT CONDITIONS

This screen displays the product temperature for each freezing cylinder. An asterisk will indicate which barrel is refrigerating. Press the MENU SELECT key to return to the operator menu.

CURRENT CONDITIONS			
1*	27.3F		
2*	27.3F		
3*	27.3F		SEL

FAULT HISTORY

This option provides a record of the last 20 faults. The display also indicates the date and time each fault occurs.

FAULT HISTORY		1
02/25/04		08:34
NO FAULT FOUND		
<- - ->	+++	---
		SEL

Press the AUTO (- ->) and OFF (<- -) keys to increase or decrease the fault page.

Page numbers are located in the upper right hand corner of the display. The most recently recorded fault will appear on page 1-1. The fault description is listed on the third line of the fault page.

FAULT HISTORY		2
07/25/10		
BRL 1 SYRUP PRESS LOW		08:33
<- - ->	+++	---
		SEL

Press the AUTO (- ->) key to move to the next screen. The next screen will indicate when the fault was satisfied.

FAULT HISTORY		2
02/25/04		14:06:19
RESTORED FROM FAULT		
PAGE 2	+++	---
		SEL

Press the MENU SELECT key to return to the operator menu.

RINSE/SANITIZE

This screen allows the operator to rinse or sanitize the freezing cylinder(s).

RINSE / SANITIZE		
RINSE	SANITIZE	EXIT
<- - ->		- - - SEL

Use the AUTO (- ->) and OFF (<- -) keys to select either RINSE or SANITIZE, and then press the MENU SELECT key.

SANITIZE		
BARREL	1 2 3	EXIT
<- - ->		- - - SEL

Use the AUTO (- ->) or OFF (<- -) keys to select barrel 1, 2, or 3. Push the MENU SELECT key to start the sanitize mode.

SERVICE MENU

This screen allows the authorized service technician to access service information. Press the MENU SELECT key to return to the operator menu.

OPERATOR MENU		
A B C D E F G H I		
SERVICE MENU		SEL
<- - ->		

Syrup Out Indicator

AUTO OUT	AUTO OUT	AUTO OK
CO2-OK		WATER-OK

If the word "OUT" appears in one of the columns below the word "AUTO", it indicates a lack of syrup or syrup pressure being supplied for the indicated freezing cylinder. If the unit is out of syrup, the product light will illuminate and a warning tone will sound for that freezing cylinder. At this time, replace the appropriate Bag-in-Box (BIB). As a safety feature, feature, the refrigeration system automatically stops to prevent a freeze-up in the freezing cylinder (barrel).

If a syrup out condition occurs on one barrel, that barrel will enter the Hold mode. During the Hold mode, refrigeration remains off, the beater continues to run if the barrel is less than 50°F (10°C) and the

CO₂ solenoid for that barrel is closed to prevent the dispensing of product. The other barrels will not be affected.

CO₂ Out Indicator

AUTO OK	AUTO OUT	AUTO OK
CO2-OUT		WATER-OK

On the LCD, if the word OUT appears next to the word CO₂ it indicates a lack of CO₂ being supplied to the freezer. The product light will also illuminate and a warning tone will sound. This will continue until the CO₂ is replaced. If the CO₂ is not replaced within 1-minute, the machine will shut down and a fault message will appear.

Water Out Indicator

AUTO OK	AUTO OUT	AUTO OK
CO2-OK		WATER-OUT

On the LCD, if the word "OUT" appears next to the word "WATER", it indicates a lack of water being supplied to the freezer. In addition, the product light will illuminate and a warning tone will sound. This will continue until the proper amount of water is supplied to the freezer. If the water is not supplied within 1-minute, the machine will shut down.

Audio Alarm Silencer

The audio alarm will be disabled if the ALARM SILENCE key is pressed. If a fault condition occurs or the system mode changes, the audio alarm will be re-enabled automatically. If the audio alarm is silenced for greater than 30-minutes without correcting the fault, it will be re-enabled automatically.

Product Light

When the light is continuously lit (not flashing), it indicates that there is an OUT condition for syrup, water, or CO₂.

When the light is flashing, it indicates that the product is not at serving viscosity. This will occur during the initial freeze down, a defrost cycle, and during power saver modes

Sampling Valve

The sampling valve is located behind the lower front panel. The sampling valve is used to obtain a brix reading.

5

Daily Procedures

The following procedure should be performed daily.

Remove the splash shield and front drip tray. Take these parts to the sink and brush-clean them.

Re-install the parts onto the freezer. Use a clean, sanitized towel and wipe down the front of the machine, including the doors and spouts.

The Model C303 has been selected to illustrate the pictured step-by-step operating procedures for both models contained in this manual. These models, for practical purposes of operation, are the same.

Note: The Model C303 contains three 7 quart (6.6 liter) freezing cylinders. The Model C314 contains four 7 quart (6.6 liter) freezing cylinders.



WARNING! This unit is pressurized when in operation.

- The control switch must be in the OFF position until the unit is completely assembled.
- No part should ever be removed from the machine while it is in operation.
- No parts should be removed until the control switch has been turned to the OFF position and all pressure has been relieved by opening the draw valve.

Failure to follow this instruction may result in severe personal injury from hazardous moving parts or from the impact of propelled parts.

The syrup flow control combines the two ingredients of carbonated water and syrup, and sends this combination to the freezing cylinder. As product is drawn, new product will flow from the flow control into the freezing cylinder.

We begin our instructions at the point where the parts are disassembled and laid out to air dry.

The following procedures will show you how to assemble the parts into the freezer, sanitize them, and prime the freezer with fresh product.

Duplicate the following procedures, where they apply, for the other freezing cylinders.

If you are disassembling the machine for the first time or need information to get to this starting point in our instructions, turn to page 6-12, Disassembly and start there.

Assembly



WARNING! Make sure the power switch is in the “OFF” position! Failure to follow this instruction may result in severe personal injury to fingers or hands from hazardous moving parts.

Note: When lubricating parts, use an approved food grade lubricant (example: Taylor Lube HP).

1. Before installing the beater drive shaft, lubricate the O-ring groove. Slide the O-ring into the groove on the drive shaft. Lubricate the drive shaft seal groove, the O-ring, and the shaft portion that comes in contact with the bearing on the beater drive shaft. **Do not** lubricate the hex end of the drive shaft.

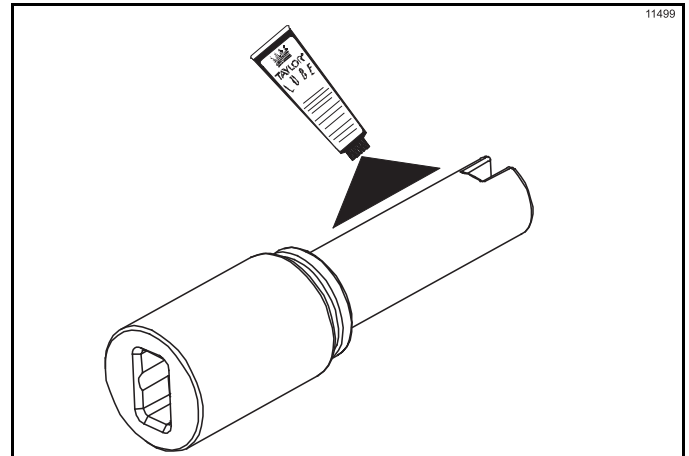

Figure 6-1

Note: To ensure that the mix does not leak out of the back of the freezing cylinder, the middle section of the boot seal should be convex or extend out from the seal. If the middle section of the boot seal is concave or extending into the middle of the seal, invert the seal

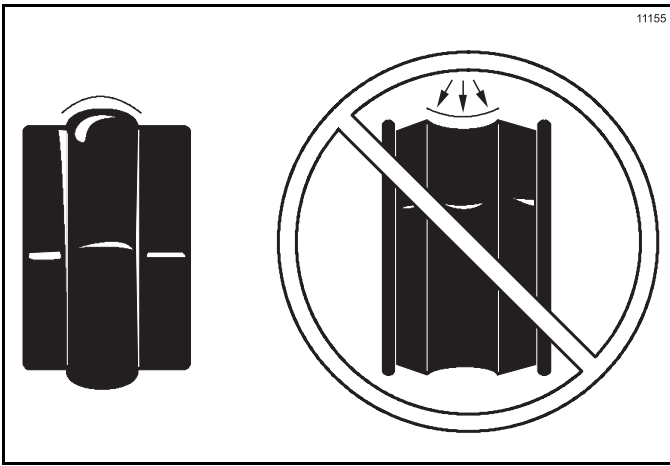

Figure 6-2

Note: The drive shaft bushing must be positioned in the center of the drive shaft seal.

2. Lubricate the inside diameter of the drive shaft seal. Install the drive shaft seal bushing in the drive shaft seal.

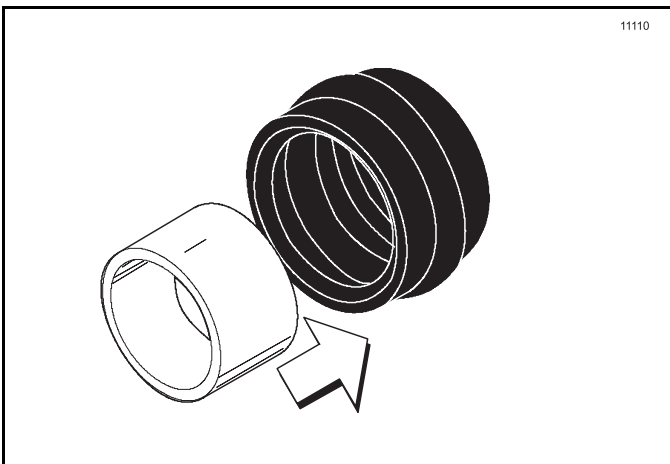

Figure 6-3

Note: The drive shaft bushing must be positioned in the center of the drive shaft seal.

3. Slide the seal and bushing over the shaft until it snaps into place.

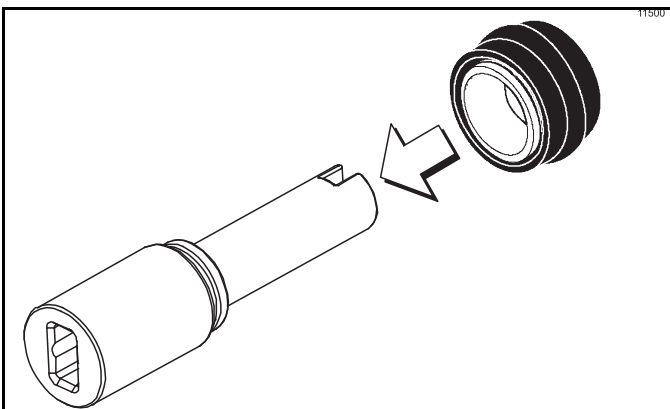

Figure 6-4

4. Fill the inside portion of the seal with 1/4" more lubricant and evenly lubricate the end of the seal that fits onto the rear shell bearing.
5. Insert the beater drive shaft into the freezing cylinder, slotted end first, and into the rear shell bearing until the seal fits securely over the rear shell bearing. Be certain the drive shaft fits into the motor shaft without binding.

Important! Remove any excess lubricant from the seal.

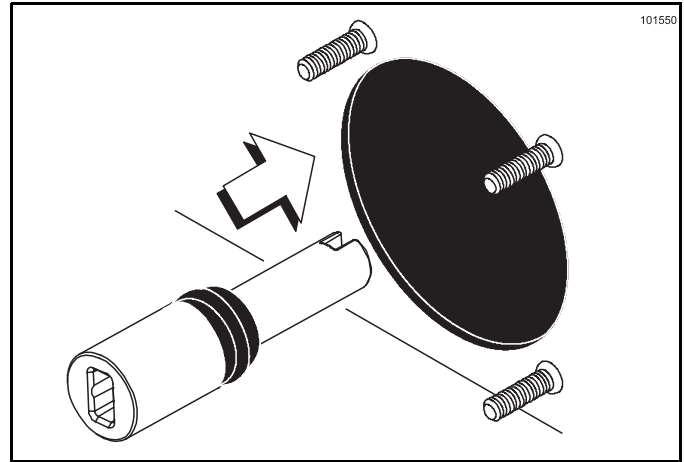

Figure 6-5

6. Before installing the beater assembly, check the scraper blades for any nicks or signs of wear. If any nicks are present or if the blade is worn, replace both blades. If the blades are in good condition, place the scraper blades over the holding pins on the beater.

Note: Each hole on the scraper blade must fit securely over each pin.

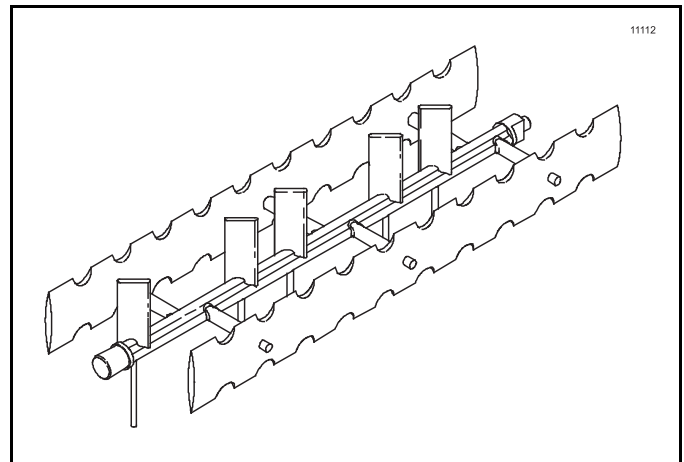

Figure 6-6

- Align the flats on the end of the beater assembly with the drive shaft. Make sure the beater assembly locating pin is in position in the locating hole of the drive shaft. Turn the beater slightly to be certain that the beater is properly seated. When in position, the beater will be approximately 3/8" inside the front of the freezing cylinder.

Important! Failure to properly seat the beater may cause damage to the beater and the door.

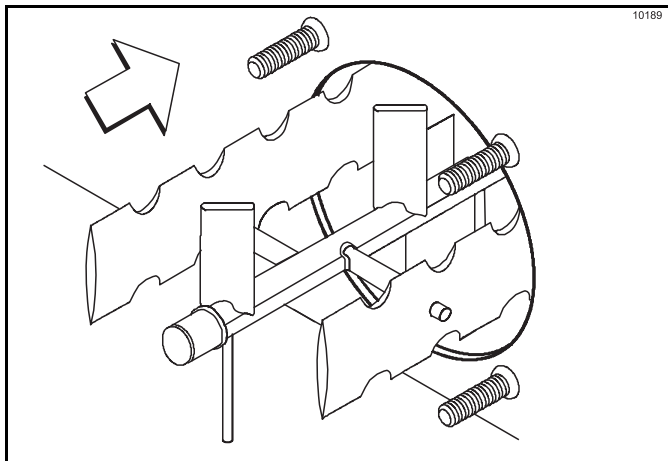

Figure 6-7

Note: The scraper blades on the beater assembly should be in the 6 and 12 o'clock positions. This will enable freezer door installation.

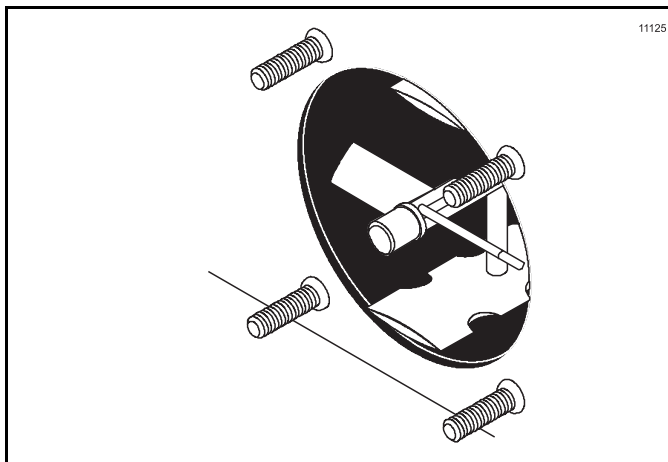

Figure 6-8

- Before installing the draw valve, slide the two o-rings into the grooves on the draw valve. Lubricate the O-rings and the valve as illustrated below.

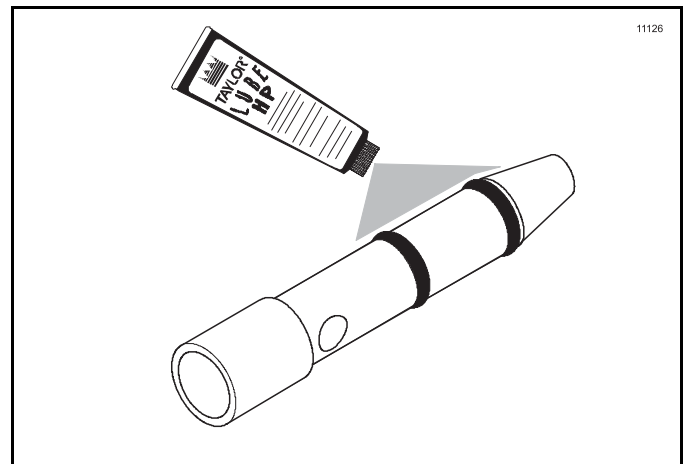

Figure 6-9

- Insert the draw valve into the freezer door spout from the front of the unit. The valve is properly installed when the hole in the draw valve is visible in the slot of the freezer door spout.

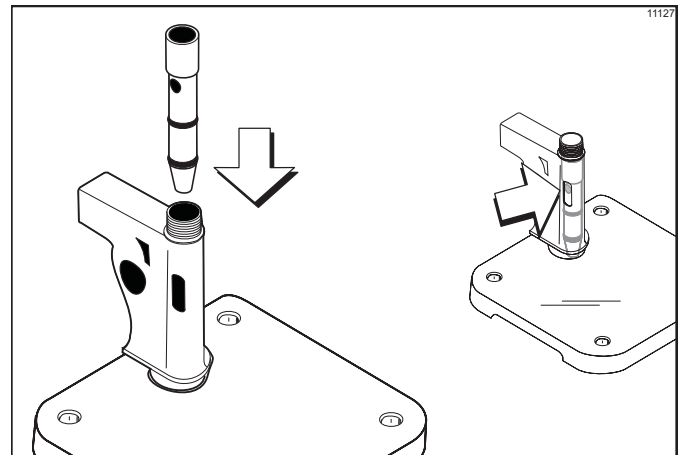

Figure 6-10

- Snap the draw valve handle onto the door spout. Align the hole in the draw valve with the slot in the draw handle.

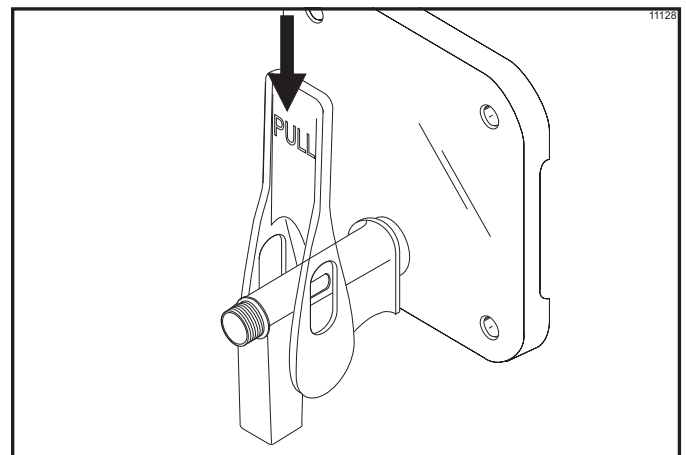

Figure 6-11

OPERATING PROCEDURES

11. Slide the pivot pin through the draw handle, the draw valve, and into the door handle slide. Secure the assembly with the 3/8" (9.5 mm) screw.

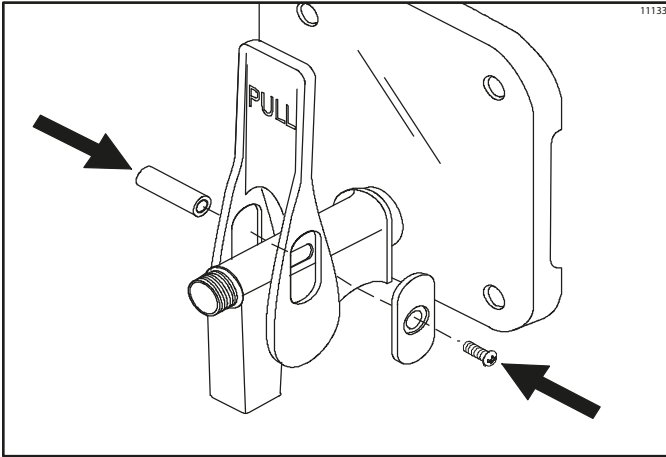

Figure 6-12

12. Install the ADA handle pin, ADA mounting adaptor, and the ADA handle. Secure the draw handle assembly with the 1" (25 mm) screw.

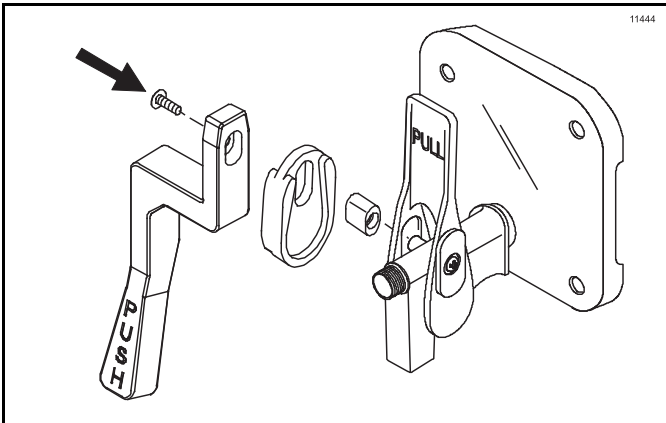

Figure 6-13

13. Insert the spring into the front of the door spout.

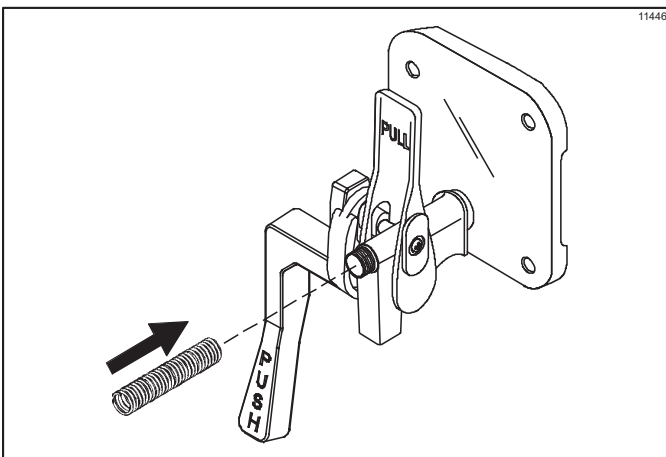

Figure 6-14

14. Place the threaded cap on the end of the draw valve cavity. Turn the cap clockwise until it is secure.

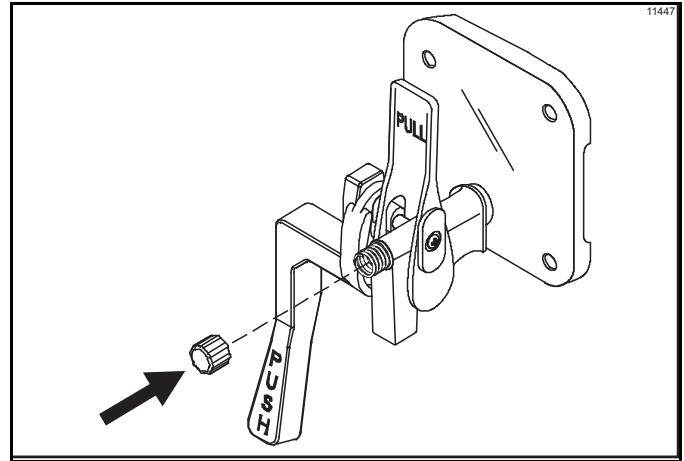

Figure 6-15

15. Place the two O-rings on the prime plug and lightly lubricate.

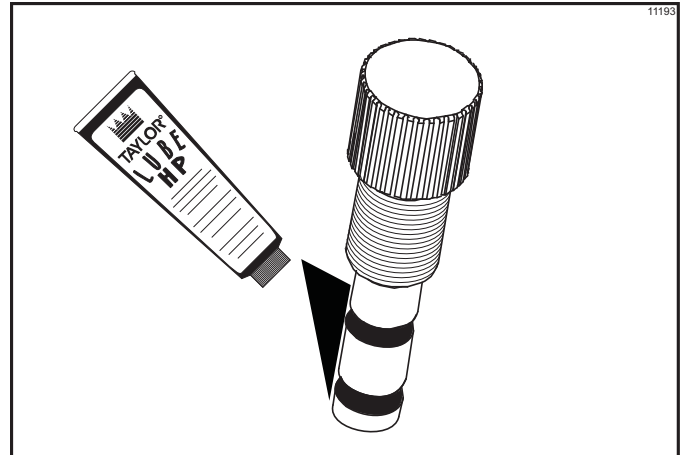

Figure 6-16

16. Install the prime plug.

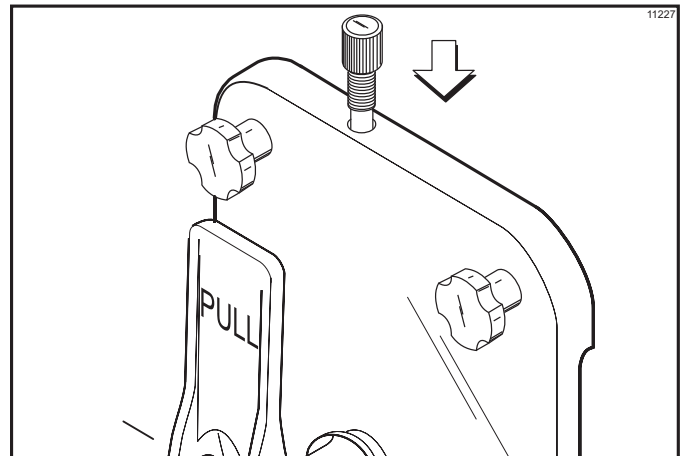

Figure 6-17

17. Place the large O-ring into the door groove and lightly lubricate.

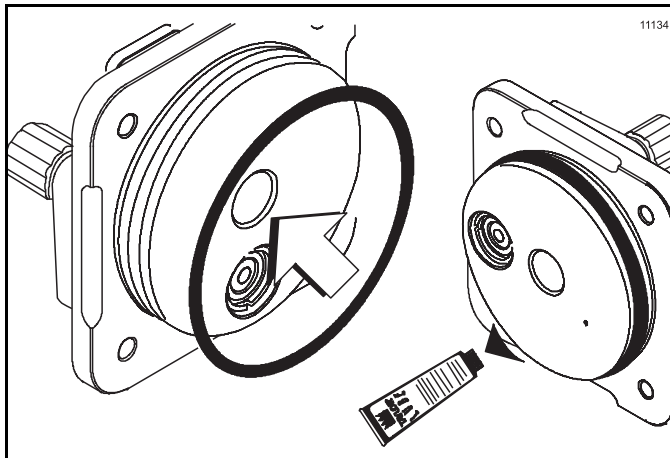

Figure 6-18

Note: Every four months or less, discard the O-rings and install new O-rings.

18. Install the front bearing. **Do not** lubricate the front bearing.

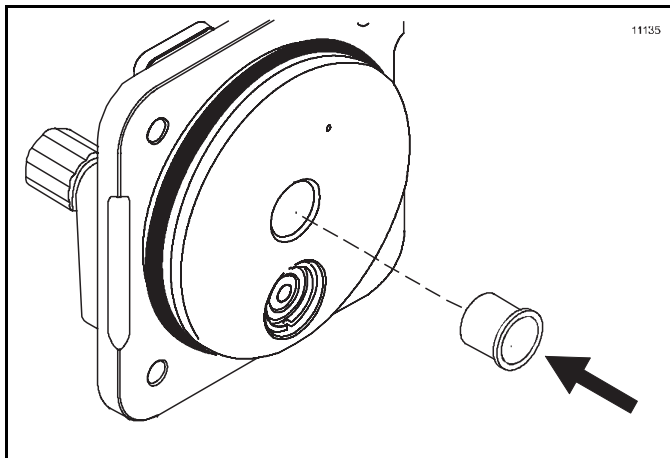

Figure 6-19

19. Install the freezer door. Position the door on the four studs on the front of the freezing cylinder. Firmly push the door into place. Install the four handscrews on the studs and finger-tighten them equally in a crisscross pattern to ensure that the door is snug. **Do not** overtighten the handscrews.

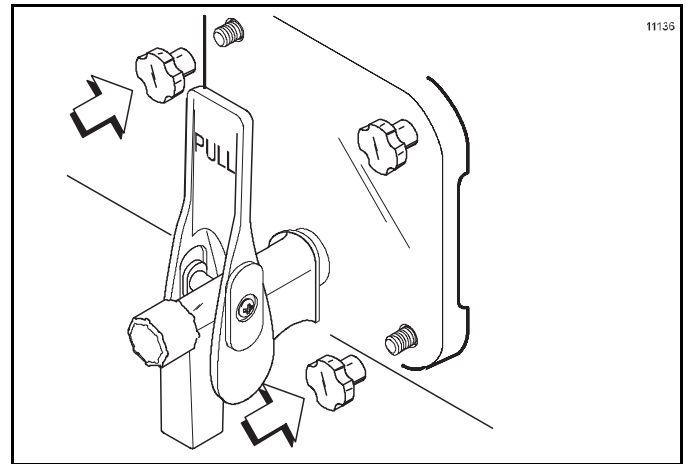

Figure 6-20

20. Repeat step 1 through step 19 for the other freezing cylinders.

Sanitizing

Important! If a machine is sanitized and will not be used for an extended period of time, clean water should be used to flush all sanitizer from the lines. Remove the water from all the lines and components prior to storage of the unit. Upon return to service, the unit must be sanitized prior to use.

1. Open the lighted display door. Place the control switch in the ON position.

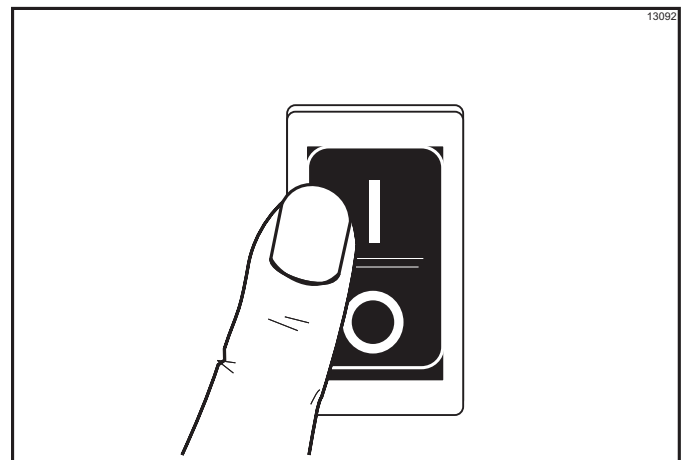

Figure 6-21

OPERATING PROCEDURES

- Prepare an approved 100 PPM sanitizing solution (examples: 2-1/2 gal. [9.5 liters] of Kay-5® or 2 gal. [7.6 liters] of Stera-Sheen®. Use warm water and follow the manufacturer's specifications.

Important! Make sure the sanitizer is completely dissolved.

- Using an empty bag of syrup, cut the syrup line connector from the end of the bag.

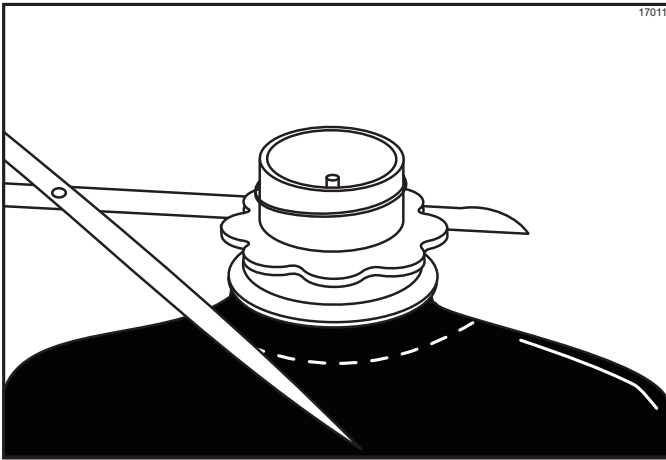

Figure 6-22

- Connect the syrup line to the syrup line connector that was cut from the syrup bag.

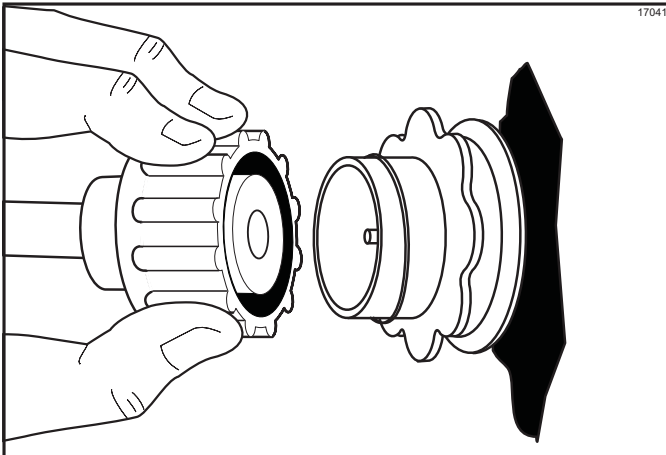

Figure 6-23

- With the bag connector attached to the syrup line, place the syrup line into the pail of sanitizing solution.

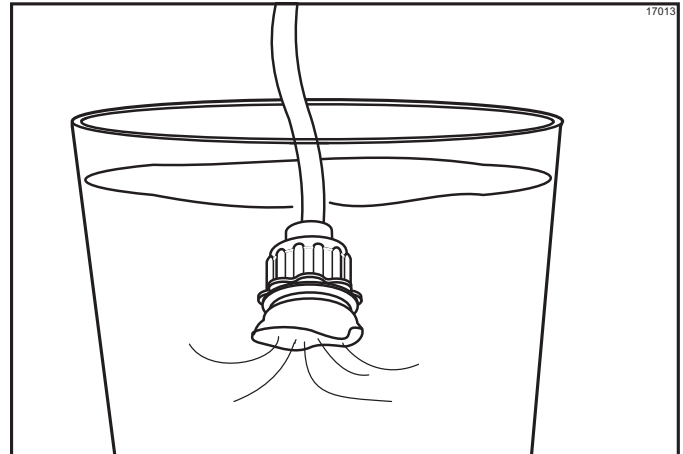
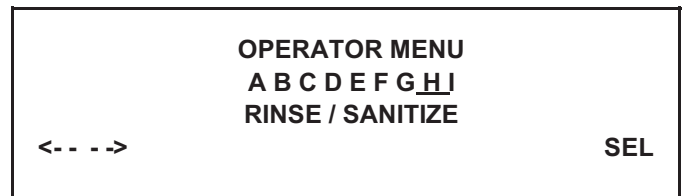
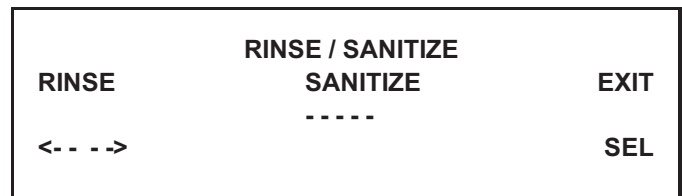

Figure 6-24

- To place a freezing cylinder in the Sanitize mode, press the MENU SELECT key. Move the cursor by pressing the AUTO (- ->) key until the third line indicates RINSE / SANITIZE.



- Press the MENU SELECT key. Move the cursor under the word SANITIZE by pressing the OFF (<- -) key.



- Pressing the MENU SELECT key will give you the option for sanitizing a freezing cylinder. Move the cursor under the desired barrel.



6

9. Press the MENU SELECT key to start the sanitize mode.
10. Repeat step 6 through step 9 for the remaining freezing cylinder.
11. Open the prime plugs. Place an empty pail under the door spouts. When sanitizing solution fills the freezing cylinders approximately 2/3 full, close the prime plugs.

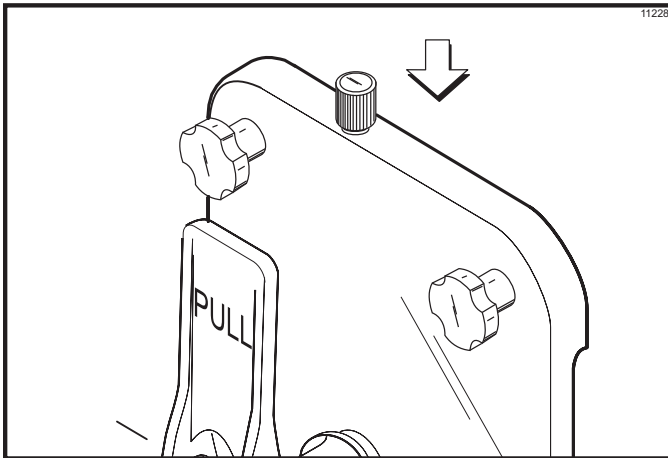

Figure 6-25

12. Continue filling the freezing cylinders with sanitizing solution until the solution purges out of the relief valve at the top of the mix tank and begins draining into the front drip tray. Press the OFF (- -) key.
13. Press the BEATER (- - -) key. Agitate the solution in the freezing cylinders for five minutes.

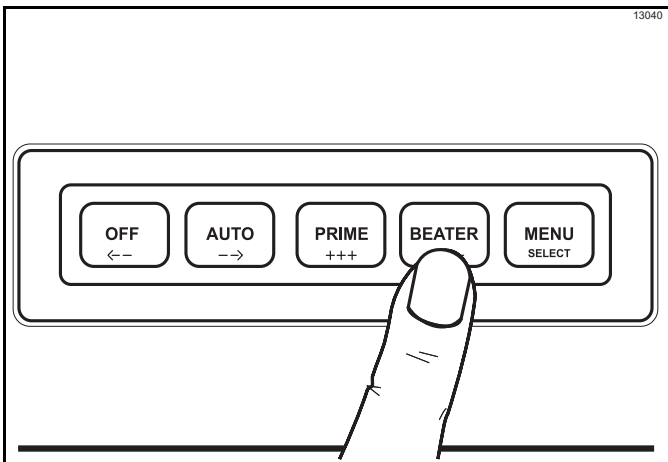

Figure 6-26

14. With a pail beneath the door spouts, open the draw valves and drain all the solution from the freezing cylinders. Press the OFF (- -) key and close the draw valves.

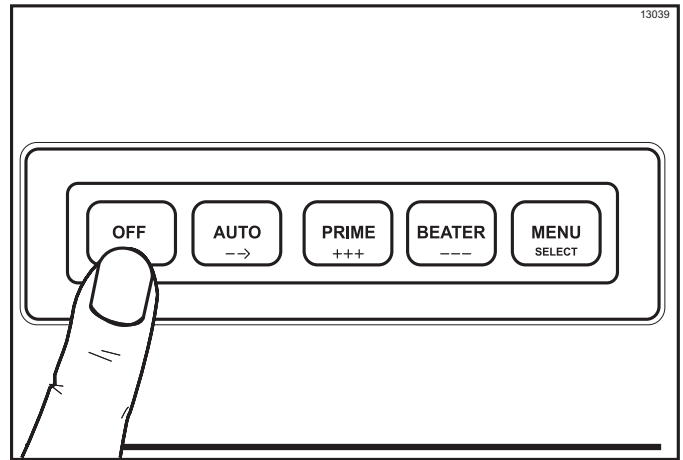

Figure 6-27

15. Disconnect the syrup connectors in the sanitizing solution.

Priming/Bringing

1. Connect the syrup line to the Bag-in-Box (BIB) syrup.
2. Remove the drip tray, splash shield, and lower front panel to gain access to the syrup sampling valves.
3. Open the prime plug.

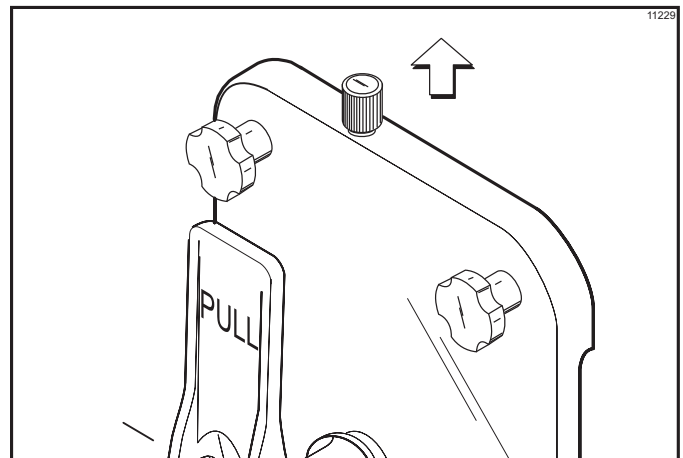

Figure 6-28

OPERATING PROCEDURES

- Place the sampling valve in the OFF (center) position.

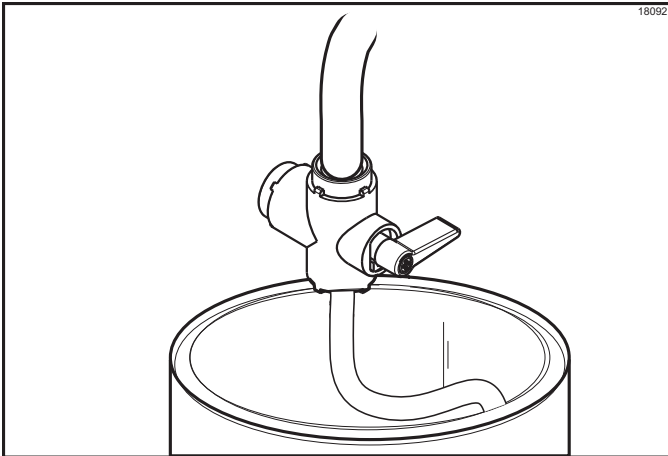

Figure 6-29

- Press the PRIME (+++) key.

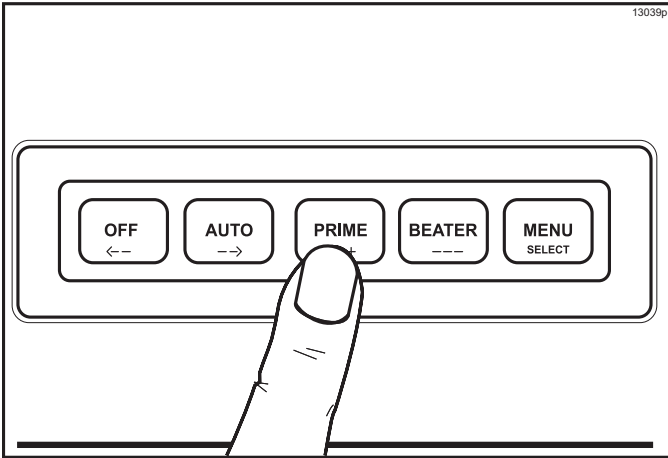

Figure 6-30

- Slowly move the syrup sampling valve to the fully open position by turning the handle down toward the sampling line. Allow the liquid to run into a pail until all the sanitizer is removed and full strength product is flowing.

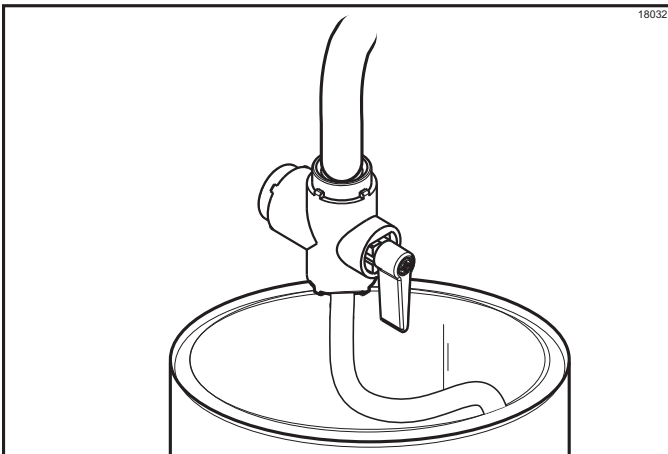

Figure 6-31

- Close the syrup sampling valve (center position). Remove the pail and place a cup under the valve.
- Open the syrup sampling valve and allow the product to flow into the cup. Close the syrup sampling valve by turning the handle to the center position.

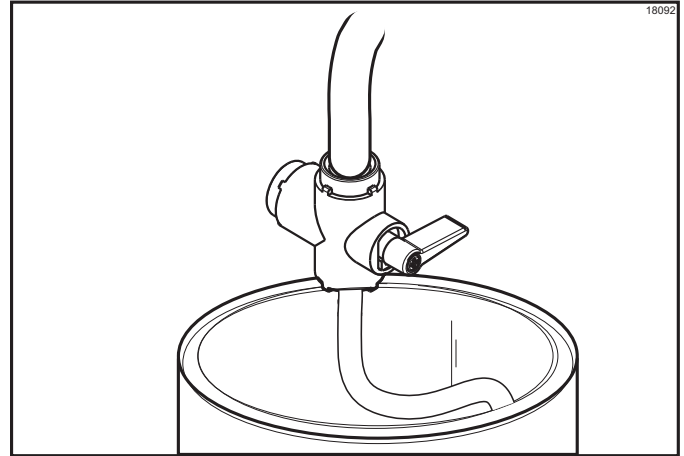

Figure 6-32

- Stir the finished product. Pour a small amount of product over the refractometer. The brix reading should register 13 to 14. A reading higher than this would cause a darker, richer product. The refrigeration system would have to run longer to freeze this excess syrup. A reading lower than this could cause a freeze-up in the freezing cylinder because of the excess water.

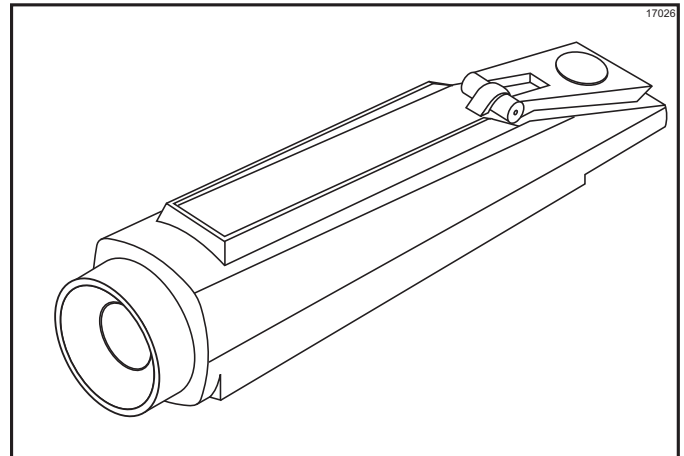

Figure 6-33

Note: Brix is the ratio of syrup to water which will directly affect the quality and taste of the product. Brixing should be done before priming the freezer and when a change in syrup flavor has been made.

- To adjust the brix, turn the adjustment screw located behind the drip tray shelf. Clockwise adjustments increase the amount of syrup to water, and counterclockwise adjustments decrease the amount of syrup to water. Adjust the screw in small increments and check the brix again. Repeat this step until a correct brix reading is registered.

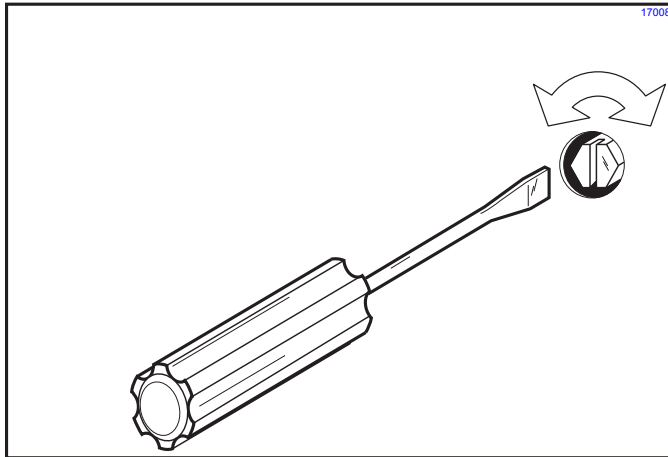

Figure 6-34

Note: Repeat this step until a correct brix reading is registered.

- Once the proper brix has been achieved, turn the handle up to allow product to flow to the mix tank.

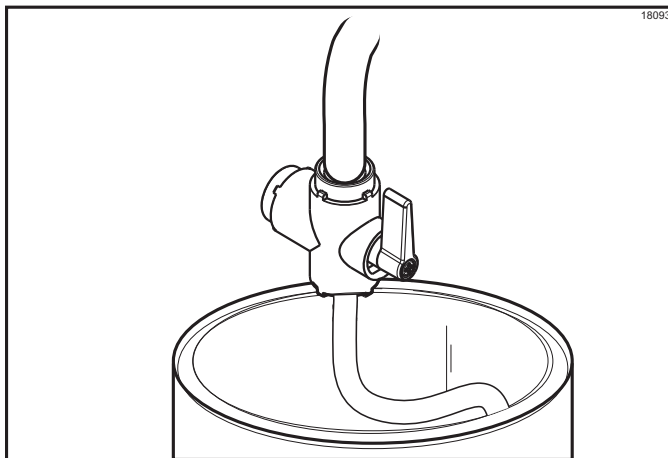

Figure 6-35

Note: The position of the handle on the syrup sampling valve determines the direction of product flow. The down position opens the syrup sampling valve for collecting brix samples. The center position shuts off the product flow. The up position directs the flow of product to the freezing cylinder.

- Place a pail beneath the door spout. Open the draw valve and drain the freezing cylinder to remove any incorrectly brixed product. Close the draw valve.

- Press the PRIME (+ + +) key. Allow the liquid level to fill to the prime plug hole.
- Repeat step 1 through step 13 for the other freezing cylinders.
- To place the freezing cylinders in the AUTO mode, press the AUTO (- ->) key for each freezing cylinder. When the unit cycles off, the product will be at serving viscosity.

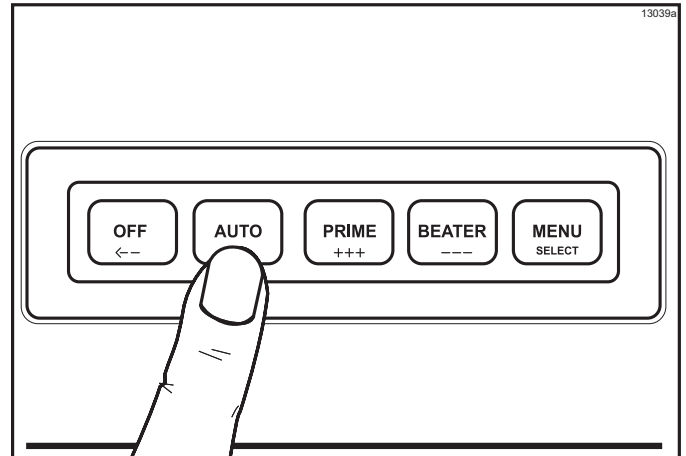

Figure 6-36

- Close the illuminated display when complete. Replace the panels and the hood, and attach with screws. Install the front drip tray and the splash shield on the front of the freezer.

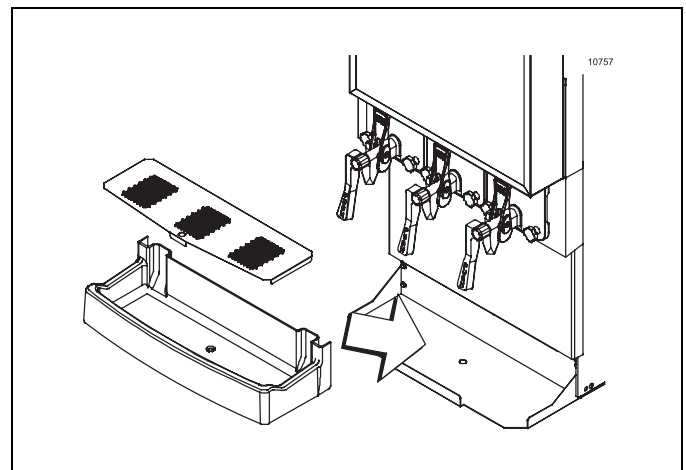

Figure 6-37

120 Day Closing Procedure

We recommend that the machine be completely disassembled and cleaned at least every 120 days using the following procedures.



To disassemble the machine, the following items will be needed:

- Two cleaning pails
- Necessary brushes (provided with freezer)
- Cleaner
- Single-service towels

Draining Product from the Freezing Cylinders

1. Press the BEATER (- - -) key. This will allow the beater to operate, and CO₂ pressure will be maintained to push the product from the freezing cylinder. Open the draw valve and drain all the product from the machine.

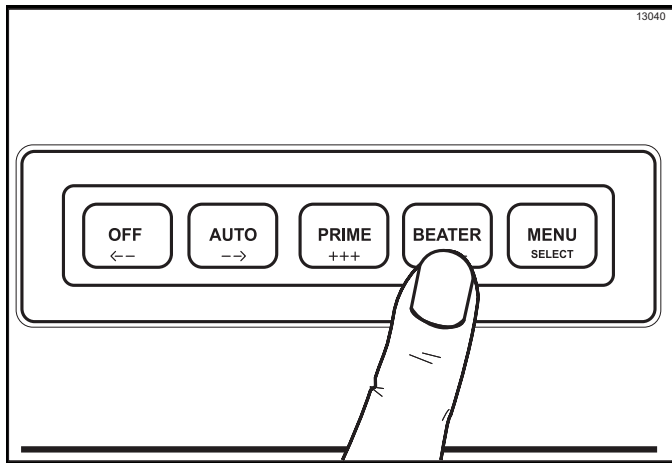

Figure 6-38

2. When all the product has been drained from the freezing cylinder, close the draw valve and press the OFF (<- -) key. Discard this product.

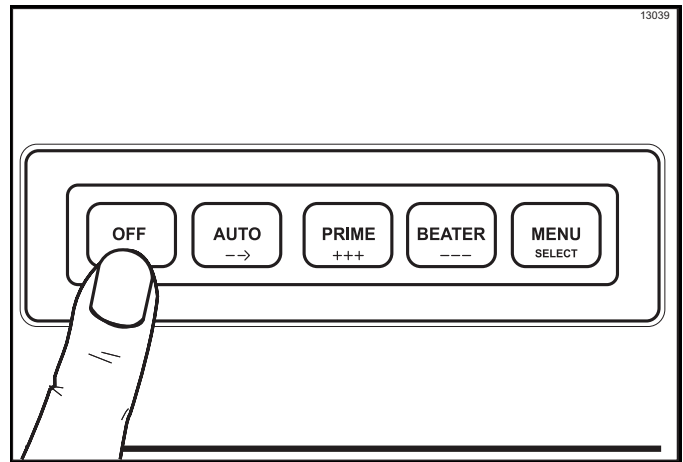
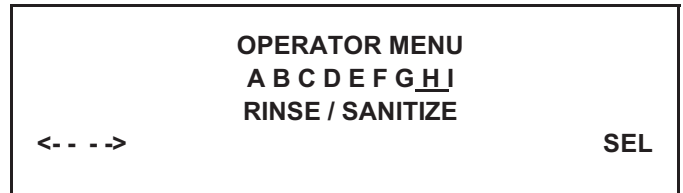

Figure 6-39

3. Repeat step 1 through step 2 for the other freezing cylinders.

Rinsing

1. To place a freezing cylinder in the RINSE mode, press the MENU SELECT key. Move the cursor by pressing the AUTO (- ->) key until the third line indicates RINSE / SANITIZE.



2. Press the MENU SELECT key. Move the cursor under RINSE by pressing the OFF (<- -) key twice.

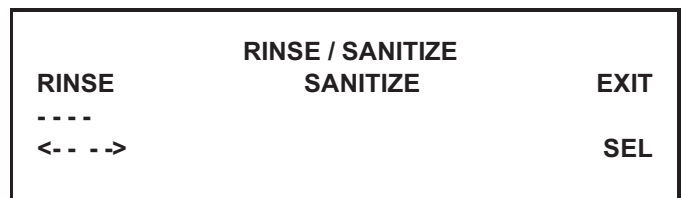

3. Pressing the MENU SELECT key will give you the option for rinsing a freezing cylinder. Move the cursor under the desired barrel.

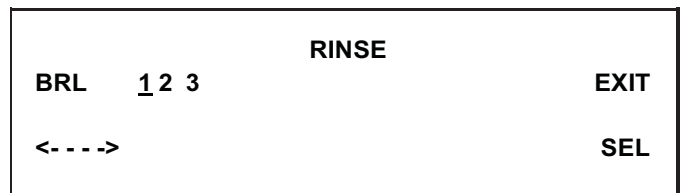

4. Pressing the MENU SELECT key at this time will start the beater motor and deliver water and CO₂ to the freezing cylinder.

- 5. Allow the rinse water to flow into the cylinder until it is approximately 2/3 full. With a pail under the door spout, open the draw valve and drain the rinse water. **Repeat this procedure** until the rinse water being drawn is clear
- 6. Repeat step 1 through step 5 for the remaining freezing cylinder.
- 7. When draining is complete, press the OFF (<- -) key.

Cleaning

- 1. Prepare an approved 100 PPM cleaning solution. (examples: 2-1/2 gal. [9.5 liters] Kay-5® or 2 gal. [7.6 liters] Stera- Sheen®). Use warm water and follow the manufacturer's specifications.
***Important!** Make sure the cleaner is completely dissolved.*
- 2. Pour the cleaning/sanitizing solution into a clean, empty pail. Place the syrup line with the old syrup connector into the pail of cleaner.
- 3. To place a freezing cylinder in the SANITIZE mode, press the MENU SELECT key. Move the cursor by pressing the AUTO (- ->) key until the third line indicates RINSE / SANITIZE.

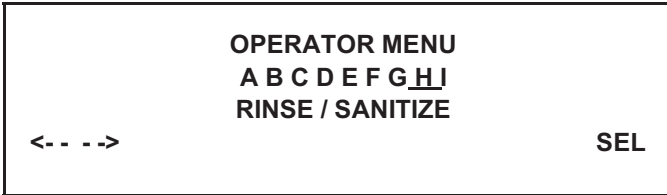

- 4. Press the MENU SELECT key. Move the cursor under the word "SANITIZE" by pressing the OFF (<- -) key.

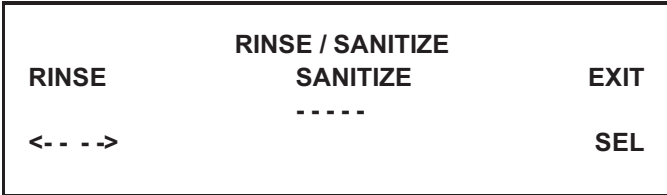

- 5. Pressing the MENU SELECT key will give you the option for sanitizing a freezing cylinder. Move the cursor under the desired barrel.



- 6. Press the MENU SELECT key to start the sanitize mode.
- 7. Repeat step 3 through step 6 for the remaining freezing cylinder.
- 8. Open the prime plugs. Allow each cylinder to fill approximately 2/3 full. Close each prime plug.
- 9. Continue filling the freezing cylinders with sanitizing solution until the solution purges out of each relief valve and begins draining into the front drip tray. The relief valves are located at the top of each mix tank. Press the OFF (<- -) key.
- 10. Press the BEATER (- - -) key to agitate the solution in each freezing cylinder for five minutes.

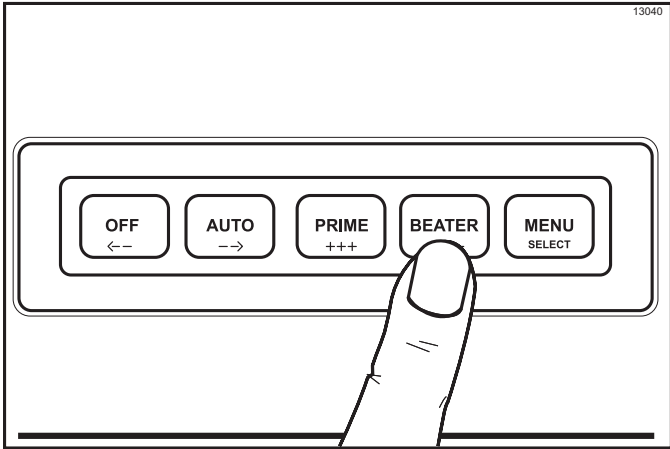

Figure 6-40

- 11. With a pail beneath the door spouts, open the draw valves and drain all the solution from the freezing cylinders. Press the OFF (<- -) key and close the draw valves.

Disassembly



WARNING! This unit is pressurized when in operation.

- The control switch must be in the OFF position until the unit is completely assembled.
- No part should ever be removed from the machine while it is in operation.
- No parts should be removed until the control switch has been turned to the OFF position and all pressure has been relieved by opening the draw valve.

Failure to follow this instruction may result in severe personal injury from hazardous moving parts or from the impact of propelled parts.

1. Open the draw valves to make sure all pressure has been relieved.
2. Open the prime plugs. Leave the prime plugs open when removing the freezer doors to ensure that all pressure is relieved from the freezing cylinders.
3. Remove the following parts from the freezer and take them to the sink for brush cleaning.
 - Hand screws
 - Freezer doors
 - Beater assemblies and scraper blades
 - Drive shafts and boot seals
 - Front drip tray
 - Splash shield

6

Brush Cleaning

1. Prepare an approved 100 PPM cleaning solution. (examples: Kay-5® or Stera- Sheen®). Use warm water and follow the manufacturer's specifications.

Important! Follow the label directions. Too strong of a solution can cause parts damage, while too mild of a solution will not provide adequate cleaning. Make sure all brushes provided with the freezer are available for brush cleaning.
2. Return to the freezer with a small amount of cleaning solution. With a single-service towel, wipe clean the rear shell bearing surface. Brush-clean the rear shell bearings at the back of the freezing cylinders with the black bristle brush.

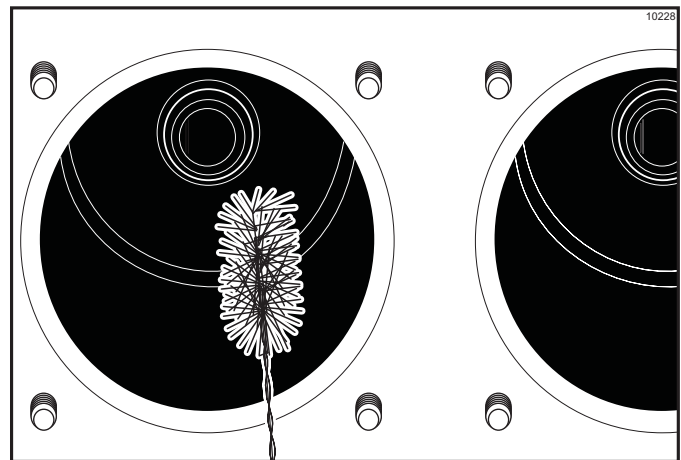

Figure 6-41

3. Remove the:
 - Seals and O-rings from the drive shafts
 - Drive shaft seal bushings from drive shaft seals
 - Caps and springs from freezer doors
 - Screws and draw handle slides from freezer doors
 - Pivot pins from draw valves
 - Draw valve handles from freezer doors
 - Draw valves from freezer doors
 - O-rings from draw valves
 - Prime plugs from freezer doors
 - O-rings from prime plugs
 - O-rings and front bearings from freezer doors

Discard all O-rings and replace them with new ones.

Note: To remove O-rings, use a single-service towel to grasp the O-ring. Apply pressure in an upward direction until the O-ring pops out of its groove. With the other hand, push the top of the O-ring forward. It will roll out of the groove and can be easily removed. If there is more than one O-ring to be removed, always remove the rear O-ring first. This will allow the O-ring to slide over the forward rings without falling into the open grooves.

4. Using a single-service towel, wipe the lubricant off the parts. Brush-clean all disassembled parts in the cleaning solution. Make sure all lubricant and syrup is removed. Place all the cleaned parts on a clean, dry surface to air-dry.
5. Wipe clean all the exterior surfaces of the freezer.

During Cleaning and Sanitizing



Cleaning and sanitizing schedules are governed by your state or local regulatory agencies and must be followed accordingly. The following checkpoints should be stressed during the cleaning and sanitizing operations.

Important! We recommend cleaning and sanitizing every 120 days.

Troubleshooting Bacterial Count

- Thoroughly clean and sanitize the machine regularly, including complete disassembly and brush cleaning.
- Use all brushes supplied for thorough cleaning. The brushes are specially designed to reach all product passageways.
- Use the black bristle brush to thoroughly clean the rear shell bearing located at the rear of the freezing cylinder. Make sure there is a generous amount of cleaning solution on the brush.
- Using a screwdriver and a cloth towel, keep the rear shell bearing and the female hex drive socket clean and free of lubricant and product deposits.
- Properly prepare the cleaning and sanitizing solutions. Read and follow the label directions carefully. Too strong of a solution may damage the parts and too weak of a solution will not do an adequate job of cleaning or sanitizing.
- Clean and sanitize the syrup lines regularly to prevent syrup residue build-up that would restrict the proper flow of syrup.
- On a regular basis, take a brix reading to ensure a consistent quality product.

Regular Maintenance Checks

- Replace scraper blades that are nicked, damaged, or worn down.
- Before installing the beater, make sure that the scraper blades are properly attached over the pins.
- Check the rear shell bearing for signs of wear (excessive product leakage from the rear drip pans to the front drip tray).
- Dispose of O-rings or seals if they are worn, torn, or fit too loosely, and replace with new ones.
- Follow all lubricating procedures as outlined in Assembly.
- Check the condenser for an accumulation of dirt and lint. A dirty condenser will reduce the efficiency and capacity of the machine. The condenser should be cleaned **monthly** by removing and cleaning the poly-flo filter.

Winter Storage

If the place of business is to be closed during the winter months, it is important to protect the freezer by following certain precautions, particularly if the building is subject to freezing conditions.

Disconnect the freezer from the main power source to prevent possible electrical damage.

Your local Taylor distributor can perform this service for you.

Wrap detachable parts of the freezer such as the beater, scraper blades, drive shaft, and freezer door. Place these parts in a protected, dry place. Rubber trim parts and gaskets can be protected by wrapping them with moisture-proof paper. All parts should be thoroughly cleaned of dried mix or lubrication, which attract mice and other vermin.

Note: It is recommended that an authorized service technician perform winter storage draining to ensure all water has been removed. This will guard against freezing and rupturing of the components.

Table 8-1

Problem	Probable Cause	Remedy	Page Ref.
1. Product is too stiff.	a. Too much water to syrup ratio. Improper brix adjustment.	a. Adjust the brix accordingly.	6-8
	b. Consistency control needs adjustment.	b. Contact a service technician.	---
	c. Torque coupling bound in warm position.	c. Contact a service technician.	---
2. Product is too soft.	a. Freezer in a defrost cycle.	a. Wait for defrost cycle to end.	---
	b. Consistency control needs adjustment.	b. Contact a service technician.	---
	c. Torque coupling bound in cold position.	c. Contact a service technician.	---
	d. Broken springs in torque coupling.	d. Contact a service technician.	---
3. No product is being dispensed.	a. Product frozen-up in freezing cylinder.	a. See problem No. 1.	---
4. Freezer will not operate in the Beater or Auto mode.	a. Unit is unplugged.	a. Check the plug at wall receptacle.	---
	b. Blown fuse, or the circuit breaker is off.	b. Replace the fuse or turn the breaker on.	---
	c. Beater motor is out on overload. Check fault description screen.	c. Allow the motor to cool. Press the AUTO (- ->) key. Call a service technician if the beater motor goes out on overload again.	5-4
	d. Unit is in Beater Overload Recovery process.	d. Allow unit to complete the recovery process.	5-5
5. No compressor operation in the Auto mode.	a. Beater motor is out on overload. Check the fault description screen.	a. Allow the motor to cool. Press the AUTO (- ->) key. Call a service technician if the beater motor goes out on overload again.	5-4
	b. The torque coupling is bound in the COLD position.	b. Contact a service technician.	---
	c. Condenser dirty, A/C.	c. Clean condenser monthly.	7-1
	d. Water supply off, W/C.	d. Turn the water on.	---
6. Unable to remove the drive shaft from the rear shell bearing.	a. Rounded corners of hex end of drive shaft, drive coupling, or both.	a. Replace the drive shaft, or call a service technician to replace the direct drive unit.	---
	b. Lubrication of hex end of drive shaft.	b. Do not lubricate the hex end. If necessary, contact a service technician for removal.	6-1
7. Excessive loss of CO ₂ .	a. Leak in the CO ₂ system.	a. Contact a service technician.	---
8. Leakage from rear drip pan(s) into front drip tray.	a. Seal or O-ring on drive shaft is worn, missing, or incorrectly installed.	a. Replace or install correctly on drive shaft.	6-1
	b. Worn rear shell bearing.	b. Contact a service technician to replace rear shell bearing.	---

TROUBLESHOOTING GUIDE

Problem	Probable Cause	Remedy	Page Ref.
9. Excessive mix leakage from door spout.	a. Inadequate lubrication of draw valve O-rings.	a. Lubricate properly.	6-1
	b. Wrong type lubricant on draw valve O-rings.	b. Use food grade lubricant (example: Taylor Lube HP).	6-1
	c. Worn or missing draw valve O-rings.	c. Replace or install O-rings on draw valve.	6-1/9-1
10. Unable to adjust brix.	a. Syrup lines need to be cleaned and sanitized.	a. Clean and sanitize syrup lines.	- - -
	b. Blocked flow control.	b. Contact a service technician.	- - -
11. Lack of syrup being supplied to machine.	a. Loss of CO ₂ to propel syrup.	a. Contact a service technician.	- - -
	b. Clogged or kinked syrup lines.	b. Sanitize syrup lines regularly. If kinked, repair or replace.	- - -

Table 9-1

Part Description	Every 4 Months	Every 8 Months	Annually
Scraper Blade		X	
Drive Shaft Seal	X		
Drive Shaft O-Ring	X		
Freezer Door O-Ring	X		
Draw Valve O-Ring	X		
Door Spout O-Ring	X		
Front Bearing	X		
Prime Plug O-Ring	X		
Black Bristle Brush, 1 in. x 2 in.		Inspect and replace if necessary.	Minimum
Double-Ended Brush		Inspect and replace if necessary.	Minimum
White Bristle Brush, 1-1/2 in. x 2 in.		Inspect and replace if necessary.	Minimum
White Bristle Brush, 3 in. x 7 in.		Inspect and replace if necessary.	Minimum

TAYLOR COMPANY LIMITED WARRANTY ON FREEZERS

Taylor Company, is pleased to provide this limited warranty on new Taylor-branded freezer equipment available from Taylor to the market generally (the "Product") to the original purchaser only.

LIMITED WARRANTY

Taylor warrants the Product against failure due to defect in materials or workmanship under normal use and service as follows. All warranty periods begin on the date of original Product installation. If a part fails due to defect during the applicable warranty period, Taylor, through an authorized Taylor distributor or service agency, will provide a new or re-manufactured part, at Taylor's option, to replace the failed defective part at no charge for the part. Except as otherwise stated herein, these are Taylor's exclusive obligations under this limited warranty for a Product failure. This limited warranty is subject to all provisions, conditions, limitations and exclusions listed below and on the reverse (if any) of this document.

Table 10-1

Product	Part	Limited Warranty Period
Soft Serve	Insulated shell assembly	Five (5) years
Frozen Yogurt Shakes	Refrigeration compressor (except service valve)	Five (5) years
Smoothies	Beater motors	Two (2) years
Frozen Beverage	Beater drive gear	Two (2) years
Batch Desserts	Printed circuit boards and Softech controls beginning with serial number H8024200	Two (2) years
	Parts not otherwise listed in this table or excluded below	One (1) year

LIMITED WARRANTY CONDITIONS

1. If the date of original installation of the Product cannot be verified, then the limited warranty period begins ninety (90) days from the date of Product manufacture (as indicated by the Product serial number). Proof of purchase may be required at time of service.
2. This limited warranty is valid only if the Product is installed and all required service work on the Product is performed by an authorized Taylor distributor or service agency, and only if genuine, new Taylor parts are used.
3. Installation, use, care, and maintenance must be normal and in accordance with all instructions contained in the Taylor Operator's Manual.
4. Defective parts must be returned to the authorized Taylor distributor or service agency for credit.
5. The use of any refrigerant other than that specified on the Product's data label will void this limited warranty.

LIMITED WARRANTY EXCEPTIONS

This limited warranty does **not** cover:

1. Labor or other costs incurred for diagnosing, repairing, removing, installing, shipping, servicing or handling of defective parts, replacement parts, or new Products.
2. Normal maintenance, cleaning and lubrication as outlined in the Taylor Operator's Manual, including cleaning of condensers.
3. Replacement of wear items designated as Class "000" parts in the Taylor Operator's Manual.
4. External hoses, electrical power supplies, and machine grounding.

LIMITED WARRANTY ON EQUIPMENT

5. Parts not supplied or designated by Taylor, or damages resulting from their use.
6. Return trips or waiting time required because a service technician is prevented from beginning warranty service work promptly upon arrival.
7. Failure, damage or repairs due to faulty installation, misapplication, abuse, no or improper servicing, unauthorized alteration or improper operation or use as indicated in the Taylor Operator's Manual, including but not limited to the failure to use proper assembly and cleaning techniques, tools, or approved cleaning supplies.
8. Failure, damage or repairs due to theft, vandalism, wind, rain, flood, high water, water, lightning, earthquake or any other natural disaster, fire, corrosive environments, insect or rodent infestation, or other casualty, accident or condition beyond the reasonable control of Taylor; operation above or below the electrical or water supply specification of the Product; or components repaired or altered in any way so as, in the judgment of the Manufacturer, to adversely affect performance, or normal wear or deterioration.
9. Any Product purchased over the Internet.
10. Failure to start due to voltage conditions, blown fuses, open circuit breakers, or damages due to the inadequacy or interruption of electrical service.
11. Electricity or fuel costs, or increases in electricity or fuel costs from any reason whatsoever.
12. Damages resulting from the use of any refrigerant other than that specified on the Product's data label will void this limited warranty.
13. Any cost to replace, refill or dispose of refrigerant, including the cost of refrigerant.
- 14. ANY SPECIAL, INDIRECT OR CONSEQUENTIAL PROPERTY OR COMMERCIAL DAMAGE OF ANY NATURE WHATSOEVER.** Some jurisdictions do not allow the exclusion of incidental or consequential damages, so this limitation may not apply to you.

This limited warranty gives you specific legal rights, and you may also have other rights which vary from jurisdiction to jurisdiction.

LIMITATION OF WARRANTY

THIS LIMITED WARRANTY IS EXCLUSIVE AND IS IN LIEU OF ALL OTHER WARRANTIES, CONDITIONS AND/OR REMEDIES UNDER THE LAW, INCLUDING ANY IMPLIED WARRANTIES OR CONDITIONS OF MERCHANTABILITY OR FITNESS FOR A PARTICULAR PURPOSE. THE ORIGINAL OWNER'S SOLE REMEDY WITH RESPECT TO ANY PRODUCTS SHALL BE REPAIR OR REPLACEMENT OF DEFECTIVE COMPONENTS UNDER THE TERMS OF THIS LIMITED WARRANTY. ALL RIGHTS TO CONSEQUENTIAL OR INCIDENTAL DAMAGES (INCLUDING CLAIMS FOR LOST SALES, LOST PROFITS, PRODUCT LOSS, PROPERTY DAMAGES OR SERVICE EXPENSES) ARE EXPRESSLY EXCLUDED. THE EXPRESS WARRANTIES MADE IN THIS LIMITED WARRANTY MAY NOT BE ALTERED, ENLARGED, OR CHANGED BY ANY DISTRIBUTOR, DEALER, OR OTHER PERSON, WHATSOEVER.

LEGAL REMEDIES

The owner **must** notify Taylor in writing, by certified or registered letter to the following address, of any defect or complaint with the Product, stating the defect or complaint and a specific request for repair, replacement, or other correction of the Product under warranty, mailed at least thirty (30) days before pursuing any legal rights or remedies.

Taylor Company
750 N. Blackhawk Blvd.
Rockton, IL 61072, U.S.A.

TAYLOR COMPANY LIMITED WARRANTY ON TAYLOR GENUINE PARTS

Taylor Company, is pleased to provide this limited warranty on new Taylor genuine replacement components and parts available from Taylor to the market generally (the "Parts") to the original purchaser only.

LIMITED WARRANTY

Taylor warrants the Parts against failure due to defect in materials or workmanship under normal use and service as follows. All warranty periods begin on the date of original installation of the Part in the Taylor unit. If a Part fails due to defect during the applicable warranty period, Taylor, through an authorized Taylor distributor or service agency, will provide a new or re-manufactured Part, at Taylor's option, to replace the failed defective Part at no charge for the Part. Except as otherwise stated herein, these are Taylor's exclusive obligations under this limited warranty for a Part failure. This limited warranty is subject to all provisions, conditions, limitations and exclusions listed below and on the reverse (if any) of this document.

Table 11-1

Part's Warranty Class Code Or Part	Limited Warranty Period
Class 103 Parts ¹	Three (3) months
Class 212 Parts ²	Twelve (12) months
Class 512 Parts	Twelve (12) months
Class 000 Parts	No warranty

LIMITED WARRANTY CONDITIONS

1. If the date of original installation of the Part cannot be otherwise verified, proof of purchase may be required at time of service.
2. This limited warranty is valid only if the Part is installed and all required service work in connection with the Part is performed by an authorized Taylor distributor or service agency.
3. The limited warranty applies only to Parts remaining in use by their original owner at their original installation location in the unit of original installation.
4. Installation, use, care, and maintenance must be normal and in accordance with all instructions contained in the Taylor Operator's Manual.
5. Defective Parts must be returned to the authorized Taylor distributor or service agency for credit.
6. This warranty is not intended to shorten the length of any warranty coverage provided pursuant to a separate Taylor Limited Warranty on freezer or grill equipment.
7. The use of any refrigerant other than that specified for the unit in which the Part is installed will void this limited warranty.

^{1, 2} Except that Taylor Part #032129SER2 (Compressor-Air-230V SERV) and Taylor Part #075506SER1 (Compressor-Air-115V 60HZ) shall have a limited warranty period of twelve (12) months when used in Taylor freezer equipment and a limited warranty period of two (2) years when used in Taylor grill equipment.

LIMITED WARRANTY ON PARTS

LIMITED WARRANTY EXCEPTIONS

This limited warranty does **not** cover:

1. Labor or other costs incurred for diagnosing, repairing, removing, installing, shipping, servicing or handling of defective Parts, replacement Parts, or new Parts.
2. Normal maintenance, cleaning and lubrication as outlined in the Taylor Operator's Manual, including cleaning of condensers or carbon and grease buildup.
3. Required service, whether cleaning or general repairs, to return the cooking surface assemblies, including the upper platen and lower plate, to an operational condition to achieve proper cooking or allow proper assembly of release sheets and clips as a result of grease build-up on the cooking surfaces, including but not limited to the platen and plate, sides of the shroud or top of the shroud.
4. Replacement of cooking surfaces, including the upper platen and lower plate, due to pitting or corrosion (or in the case of the upper platen, due to loss of plating) as a result of damage due to the impact of spatulas or other small wares used during the cooking process or as a result of the use of cleaners, cleaning materials or cleaning processes not approved for use by Taylor.
5. Replacement of wear items designated as Class "000" Parts in the Taylor Operator's Manual, as well as any release sheets and clips for the Product's upper platen assembly.
6. External hoses, electrical power supplies, and machine grounding.
7. Parts not supplied or designated by Taylor, or damages resulting from their use.
8. Return trips or waiting time required because a service technician is prevented from beginning warranty service work promptly upon arrival.
9. Failure, damage or repairs due to faulty installation, misapplication, abuse, no or improper servicing, unauthorized alteration or improper operation or use as indicated in the Taylor Operator's Manual, including but not limited to the failure to use proper assembly and cleaning techniques, tools, or approved cleaning supplies.
10. Failure, damage or repairs due to theft, vandalism, wind, rain, flood, high water, water, lightning, earthquake or any other natural disaster, fire, corrosive environments, insect or rodent infestation, or other casualty, accident or condition beyond the reasonable control of Taylor; operation above or below the gas, electrical or water supply specification of the unit in which a part is installed; or Parts or the units in which they are installed repaired or altered in any way so as, in the judgment of Taylor, to adversely affect performance, or normal wear or deterioration.
11. Any Part purchased over the Internet.
12. Failure to start due to voltage conditions, blown fuses, open circuit breakers, or damages due to the inadequacy or interruption of electrical service.
13. Electricity, gas or other fuel costs, or increases in electricity or fuel costs from any reason whatsoever.
14. Damages resulting from the use of any refrigerant other than that specified for the unit in which the Part is installed will void this limited warranty.
15. Any cost to replace, refill or dispose of refrigerant, including the cost of refrigerant.
16. **ANY SPECIAL, INDIRECT OR CONSEQUENTIAL PROPERTY OR COMMERCIAL DAMAGE OF ANY NATURE WHATSOEVER.** Some jurisdictions do not allow the exclusion of incidental or consequential damages, so this limitation may not apply to you.

This limited warranty gives you specific legal rights, and you may also have other rights which vary from jurisdiction to jurisdiction.

LIMITATION OF WARRANTY

THIS LIMITED WARRANTY IS EXCLUSIVE AND IS IN LIEU OF ALL OTHER WARRANTIES, CONDITIONS AND/OR REMEDIES UNDER THE LAW, INCLUDING ANY IMPLIED WARRANTIES OR CONDITIONS OF MERCHANTABILITY OR FITNESS FOR A PARTICULAR PURPOSE. THE ORIGINAL OWNER'S SOLE REMEDY WITH RESPECT TO ANY PRODUCTS SHALL BE REPAIR OR REPLACEMENT OF DEFECTIVE PARTS UNDER THE TERMS OF THIS LIMITED WARRANTY. ALL RIGHTS TO CONSEQUENTIAL OR INCIDENTAL DAMAGES (INCLUDING CLAIMS FOR LOST SALES, LOST PROFITS, PRODUCT LOSS, PROPERTY DAMAGES OR SERVICE EXPENSES) ARE EXPRESSLY EXCLUDED. THE EXPRESS WARRANTIES MADE IN THIS LIMITED WARRANTY MAY NOT BE ALTERED, ENLARGED, OR CHANGED BY ANY DISTRIBUTOR, DEALER, OR OTHER PERSON, WHATSOEVER.

LEGAL REMEDIES

The owner **must** notify Taylor in writing, by certified or registered letter to the following address, of any defect or complaint with the Part, stating the defect or complaint and a specific request for repair, replacement, or other correction of the Part under warranty, mailed at least thirty (30) days before pursuing any legal rights or remedies.

Taylor Company
750 N. Blackhawk Blvd.
Rockton, IL 61072, U.S.A.

