

OPERATOR'S MANUAL



Model C001 and C002 Custard Freezers

Original Operating Instructions

055073-M

5/28/08 (Original Publication)
(Updated 8/18/2020)

Section 1: To the Installer

Installer Safety	1-1
Site Preparation	1-1
Air-Cooled Machines.....	1-2
Water Connections.....	1-2
Electrical Connections.....	1-2
Dasher (Beater) Rotation	1-3
Refrigerant	1-3

Section 2: To the Operator

Section 3: Safety

Section 4: Operator Parts Identification

C001 Exploded View.....	4-1
C002 Exploded View.....	4-3
Dasher (Beater) and Door Assembly	4-5
Accessories.....	4-6

Section 5: User Interface

C001.....	5-1
C002.....	5-2
Symbol Definitions	5-3

Section 6: Operating Procedures

Assembly.....	6-1
Sanitizing.....	6-4
Priming for Continuous Run	6-4
Stopping a Continuous Run for a Short Period of Time	6-5
To Restart the Continuous Run:.....	6-5
Closing Procedure.....	6-6
Draining Product From the Freezing Cylinder.....	6-6
Rinsing	6-6
Cleaning.....	6-6
Disassembly.....	6-7
Brush-Cleaning	6-7

Section 7: Important: Operator Checklist

During Cleaning and Sanitizing.....	7-1
Troubleshooting Bacterial Count.....	7-1
Regular Maintenance Checks	7-2
Winter Storage	7-2

Section 8: Troubleshooting Guide

Section 9: Parts Replacement Schedule

Section 10: Limited Warranty on Machines

Section 11: Limited Warranty on Parts

The following information has been included in the manual as safety and regulatory guidelines. For complete installation instructions, please see the Installation Checklist.

Installer Safety



IMPORTANT! In all areas of the world, machines should be installed in accordance with existing local codes. Please contact your local authorities if you have any questions.

Care should be taken to ensure that all basic safety practices are followed during the installation and servicing activities related to the installation and service of Taylor machines.

- Only Taylor service personnel should perform installation and repairs on the machine.
- Authorized service personnel should consult OSHA Standard 29CFR1910.147 or the applicable code of the local area for the industry standards on lockout/tagout procedures before beginning any installation or repairs.
- Authorized service personnel must ensure that the proper personal protective equipment (PPE) is available and worn when required during installation and service.
- Authorized service personnel must remove all metal jewelry, rings, and watches before working on electrical equipment.



DANGER! The main power supply(s) to the machine must be disconnected prior to performing any repairs. Failure to follow this instruction may result in personal injury or death from electrical shock or hazardous moving parts, as well as poor performance or damage to the machine.



WARNING! This machine has many sharp edges that can cause severe injuries.

Site Preparation

Review the area where the machine will be installed before uncrating. Make sure that all possible hazards to the user and the machine have been addressed.



WARNING! Only install this machine in a location where its use and maintenance is restricted to trained personnel. Failure to comply may result in personal injury.

For Indoor Use Only: This machine is designed to operate indoors, under normal ambient temperatures of 70°F to 75°F (21°C to 24°C). The freezer has successfully performed in high ambient temperatures of 104°F (40°C) at reduced capacities.



WARNING! This machine must **NOT** be installed in an area where a water jet or hose can be used. **NEVER** use a water jet or hose to rinse or clean the machine. Failure to follow this instruction may result in electrocution.



CAUTION! This machine must be installed on a level surface to avoid the hazard of tipping. Extreme care should be taken in moving this machine for any reason. Two or more persons are required to safely move this machine. Failure to comply may result in personal injury or machine damage.

Uncrate the machine and inspect it for damage. Report any damage to your Taylor distributor.

This machine is made in the USA and uses USA hardware sizes. All metric conversions are approximate.

Air-Cooled Machines

Do not obstruct air intake and discharge openings.

Air-cooled machines require a minimum of 3 in. (76 mm) of clearance around **all** sides of the freezer. Install the deflector provided to prevent recirculation of warm air. Failure to allow adequate clearance can reduce the refrigeration capacity of the freezer and possibly cause permanent damage to the compressors.

1

Water Connections

(Water-Cooled Machines Only)

An adequate cold water supply must be provided with a hand shut-off valve. On the underside rear of the base pan, two 1/2 in. (13 mm) I.P.S. water connections for inlet and outlet have been provided for easy hook-up. Permanently connect the machine using 1/2 in. (12.7 mm) inside diameter water lines. (Flexible lines are recommended, if local codes permit.) Depending on local water conditions, it may be advisable to install a water strainer to prevent foreign substances from clogging the automatic water valve. There will be only one water-in and one water-out connection. **Do not** install a hand shut-off valve on the water-out line. Water should always flow in this order: first, through the automatic water valve; second, through the condenser; and third, through the outlet fitting to an **open trap drain**.



IMPORTANT! A backflow prevention device is required on the incoming water connection side. Please see the applicable national, state, and local codes for determining the proper configuration. Water pressure to the unit must not exceed 150 psi (1034 kPa).

Electrical Connections



IMPORTANT! In the United States, this machine is intended to be installed in accordance with the National Electrical Code (NEC), ANSI/NFPA 701987. The purpose of the NEC code is the practical safeguarding of persons and property from hazards arising from the use of electricity. This code contains provisions considered necessary for safety.

In all other areas of the world, the machine should be installed in accordance with the existing local codes. Please contact your local authorities if you have any questions.

Each machine requires one power supply for each data label on the machine. Check the data label(s) on the machine for branch circuit overcurrent protection or fuse, circuit ampacity, and other electrical specifications.

See the wiring diagram provided inside the electrical box for proper power connections.



FOLLOW YOUR LOCAL ELECTRICAL CODES.



WARNING! This machine must be properly grounded! Failure to do so can result in severe personal injury from electrical shock!



IMPORTANT! This machine is provided with an equipotential grounding lug that is to be properly attached to the rear of the frame by the authorized installer. The installation location is marked by the equipotential bonding symbol (5021 of IEC 60417-1) on the removable panel and the frame.



WARNING! Avoid injury.

- **DO NOT** operate the machine unless it is properly grounded.
- **DO NOT** operate the machine with fuses larger than specified on the machine's data label.
- All repairs should be performed by an authorized Taylor service technician.
- The main power supplies to the machine must be disconnected prior to performing installation, repairs, or maintenance.
- **For Cord-Connected Machines:** Only Taylor service technicians or licensed electricians may install a plug or replacement cord on the machine.
- Machines that are permanently connected to fixed wiring and for which leakage currents may exceed 10 mA, particularly when disconnected or not used for long periods, or during initial installation, shall have protective devices to protect against the leakage of current, such as a GFI, installed by the authorized personnel to local codes.
- Stationary machines that are not equipped with a power cord and a plug or another device to disconnect the appliance from the power source must have an all-pole disconnecting device with a contact gap of at least 0.125 in. (3 mm) in the external installation.
- Supply cords used with this machine shall be oil-resistant, sheathed flexible cable not lighter than ordinary polychloroprene or other equivalent synthetic elastomer-sheathed cord (code designation 60245 IEC 57) installed with the proper cord anchorage to relieve conductors from strain, including twisting, at the terminals and protect the insulation of the conductors from abrasion.
- If the supply cord is damaged, it must be replaced by the manufacturer, service agent, or a similarly qualified person to avoid a hazard.
- Secure supply cord ground lead to machine in a location where if the cord is pulled the main power leads become taut before the ground lead can break loose.

Failure to follow these instructions may result in electrocution. Contact your local authorized Taylor distributor for service.

Dasher (Beater) Rotation



NOTICE! Dasher (beater) rotation must be clockwise as viewed looking into the freezing cylinder. As a safety feature, the dasher will not operate without the freezer door in place.

Note: *The following procedures must be performed by a Taylor service technician.*

To correct the rotation on a three-phase machine, interchange any two incoming power supply lines at freezer main terminal block only.

To correct rotation on a single-phase machine, change the leads inside the dasher motor. (Follow the diagram printed on the motor.)

Electrical connections are made directly to the terminal block. The terminal block is provided in the control box located behind the lower front panel.

Refrigerant



CAUTION! This machine contains fluorinated greenhouse gases (F-Gas) to provide refrigeration using a hermetically sealed circuit or within foam insulation. This machine's type of gas, quantity, Global Warming Potential (GWP), and CO₂ tonnes equivalent information is recorded on the machine's data-label. The refrigerant used is generally considered nontoxic and nonflammable. However any gas under pressure is potentially hazardous and must be handled with caution.

NEVER fill any refrigerant cylinder completely with liquid. Filling the cylinder approximately 80% will allow for normal expansion



CAUTION! Use only approved refrigerant listed on the machine's data label or authorized through a manufacturer's technical bulletin. The use of any other refrigerant may expose users and operators to unexpected safety hazards.

1



WARNING! Refrigerant liquid sprayed onto the skin may cause serious damage to tissue. Keep eyes and skin protected. If refrigerant burns should occur, flush the area immediately with cold water. If burns are severe, apply ice packs and contact a physician immediately.



NOTICE! Taylor reminds technicians to be aware of and in compliance with local government laws regarding refrigerant recovery, recycling, and reclaiming systems. For information regarding applicable local laws, please contact your local authorized Taylor distributor.



IMPORTANT! *Refrigerants and their associated lubricants may be extremely moisture absorbent. When opening a refrigeration system, the maximum time the system is open must not exceed 15 minutes. Cap all open tubing to prevent humid air or water from being absorbed by the oil.*

The freezer you have purchased has been carefully engineered and manufactured to give you dependable operation. The Taylor freezer, when properly operated and cared for, will produce a consistent quality product. Like all mechanical products, this machine will require cleaning and maintenance. A minimum amount of care and attention is necessary if the operating procedures outlined in this manual are followed closely.

This Operator's Manual should be read before operating or performing any maintenance on your machine.

Your Taylor freezer will **not** eventually compensate and correct for any errors during the setup or filling operations. Thus, the initial assembly and priming procedures are of extreme importance. It is strongly recommended that all personnel responsible for the machine's operation review these procedures in order to be properly trained and to make sure that there is no confusion.

In the event you should require technical assistance, please contact your local authorized Taylor distributor.

Note: *Your Taylor warranty is valid only if the parts are authorized Taylor parts, purchased from the local authorized Taylor distributor, and only if all required service work is provided by an authorized Taylor service technician. Taylor reserves the right to deny warranty claims on machines or parts if non-Taylor approved parts or incorrect refrigerant were installed in the machine, system modifications were performed beyond factory recommendations, or it is determined that the failure was caused by abuse, misuse, neglect, or failure to follow all operating instructions. For full details of your Taylor warranty, please see the Limited Warranty section in this manual.*



IMPORTANT! If the crossed-out wheeled-bin symbol is affixed to this machine, it signifies that this machine is compliant with the EU directives as well as other similar end-of-life legislation in effect after August 13, 2005. Therefore, it must be collected separately after its use is completed and cannot be disposed as unsorted municipal waste.

The user is responsible for delivering the machine to the appropriate collection facility, as specified by your local code.

For additional information regarding applicable local disposal laws, please contact the municipal waste facility and/or local authorized Taylor distributor.

Compressor Warranty Disclaimer

The refrigeration compressor(s) on this machine are warranted for the term stated in the Limited Warranty section in this manual. However, due to the Montreal Protocol and the U.S. Clean Air Act Amendments of 1990, many new refrigerants are being tested and developed, thus seeking their way into the service industry. Some of these new refrigerants are being advertised as drop-in replacements for numerous applications. It should be noted that in the event of ordinary service to this machine's refrigeration system, **only the refrigerant specified on the affixed data label should be used.** The unauthorized use of alternate refrigerants will void your Taylor compressor warranty. It is the machine owner's responsibility to make this fact known to any technician he/she employs.

It should also be noted that Taylor does not warrant the refrigerant used in its machines. For example, if the refrigerant is lost during the course of ordinary service to this machine, Taylor has no obligation to either supply or provide its replacement either at billable or non-billable terms. Taylor does have the obligation to recommend a suitable replacement if the original refrigerant is banned, obsoleted, or no longer available during the five year warranty of the compressor.

Taylor Company will continue to monitor the industry and test new alternates as they are being developed. Should a new alternate prove, through our testing, then it would be accepted as a drop-in replacement, then the above disclaimer would become null and void. To find the current status of an alternate refrigerant as it relates to your compressor warranty, call the local Taylor distributor or the Taylor factory. Be prepared to provide the model/serial number of the machine in question.

We at Taylor Company are concerned about the safety of the operator when he or she comes in contact with the freezer and its parts. Taylor has gone to extreme efforts to design and manufacture built-in safety features to protect operators and the service technicians. As an example, warning labels have been attached to the freezer to further point out safety precautions to the operator.



DANGER! Failure to adhere to the following safety precautions may result in severe personal injury or death. Failure to comply with these warnings may also damage the machine and/or its components. Such damage may require component replacement and service repair expenses.



NOTICE! DO NOT operate the machine without reading the Operator's Manual. Failure to follow this instruction may result in machine damage, poor machine performance, health hazards, or personal injury.



IMPORTANT! *This machine is to be used only by trained personnel. It is not intended for use, cleaning, or maintenance by children or people with reduced physical, sensory, or mental capabilities or lack of experience and knowledge, unless given supervision or instruction concerning the use of the machine by a person responsible for their safety. Children should be supervised to ensure that they do not play with the machine.*



IMPORTANT! *This machine is provided with an equipotential grounding lug that is to be properly attached to the rear of the frame by the authorized installer. The installation location is marked by the equipotential bonding symbol (5021 of IEC 60417-1) on the removable panel and the frame.*



WARNING! This machine must **NOT** be installed in an area where a water jet or hose can be used. **NEVER** use a water jet or hose to rinse or clean the machine. Failure to follow this instruction may result in electrocution.



WARNING! Avoid injury.

- **DO NOT** operate the machine unless it is properly grounded.
- **DO NOT** operate the machine with fuses larger than specified on the machine's data label.
- All repairs should be performed by an authorized Taylor service technician.
- The main power supplies to the machine must be disconnected prior to performing installation, repairs, or maintenance.
- **For Cord-Connected Machines:** Only Taylor service technicians or licensed electricians may install a plug or replacement cord on the machine.
- Machines that are permanently connected to fixed wiring and for which leakage currents may exceed 10 mA, particularly when disconnected or not used for long periods, or during initial installation, shall have protective devices to protect against the leakage of current, such as a GFI, installed by the authorized personnel to local codes.
- Stationary machines that are not equipped with a power cord and a plug or another device to disconnect the appliance from the power source must have an all-pole disconnecting device with a contact gap of at least 0.125 in. (3 mm) in the external installation.
- Supply cords used with this machine shall be oil-resistant, sheathed flexible cable not lighter than ordinary polychloroprene or other equivalent synthetic elastomer-sheathed cord (code designation 60245 IEC 57) installed with

the proper cord anchorage to relieve conductors from strain, including twisting, at the terminals and protect the insulation of the conductors from abrasion.

- If the supply cord is damaged, it must be replaced by the manufacturer, service agent, or a similarly qualified person to avoid a hazard.
- Secure supply cord ground lead to machine in a location where if the cord is pulled the main power leads become taut before the ground lead can break loose.

Failure to follow these instructions may result in electrocution. Contact your local authorized Taylor distributor for service.

3



WARNING! Avoid injury.

- **DO NOT** allow untrained personnel to operate this machine.
- **DO NOT** put objects or fingers in the door spout.
- **DO NOT** operate the machine unless all service panels and access doors are restrained with screws.
- **DO NOT** remove the machine door or beater assembly unless the control switches are in the Off position.

Failure to follow these instructions may result in contaminated product or severe personal injury to fingers or hands from hazardous moving parts.



WARNING! This machine has many sharp edges that can cause severe injuries.

- **DO NOT** put objects or fingers in the door opening. This may contaminate the product and cause severe personal injury from blade contact.
- **USE EXTREME CAUTION** when removing the beater assembly. The scraper blades are very sharp and may cause injury.



CAUTION! This machine must be placed on a level surface. Failure to comply may result in personal injury or machine damage.



WARNING! Only install this machine in a location where its use and maintenance is restricted to trained personnel. Failure to comply may result in personal injury.



NOTICE! Cleaning and sanitizing schedules are governed by your federal, state, or local regulatory agencies and must be followed accordingly. Please see the cleaning section of this manual for the proper procedure to clean this machine.



CAUTION! This machine is designed to maintain product temperature under 41°F (5°C). Any product being added to this machine must be below 41°F (5°C). Failure to follow this instruction may result in health hazards and poor machine performance.

Do not obstruct air intake and discharge openings: 3 in. (76 mm) minimum air space on all sides. Install the deflector provided to prevent recirculation of warm air. Failure to follow this instruction may cause poor freezer performance and damage to the machine.

For Indoor Use Only: This machine is designed to operate indoors, under normal ambient temperatures of 70°F to 75°F (21°C - 24°C). The machine has successfully performed in high ambient temperatures of up to 104°F (40°C) at reduced capacities.

Do not run the machine without product. Failure to follow this instruction can result in damage to the machine.

NOISE LEVEL: Airborne noise emission does not exceed 78 dB(A) when measured at a distance of 39 in. (1.0 m) from the surface of the machine and at a height of 62 in. (1.6 m) from the floor.

C001 Exploded View

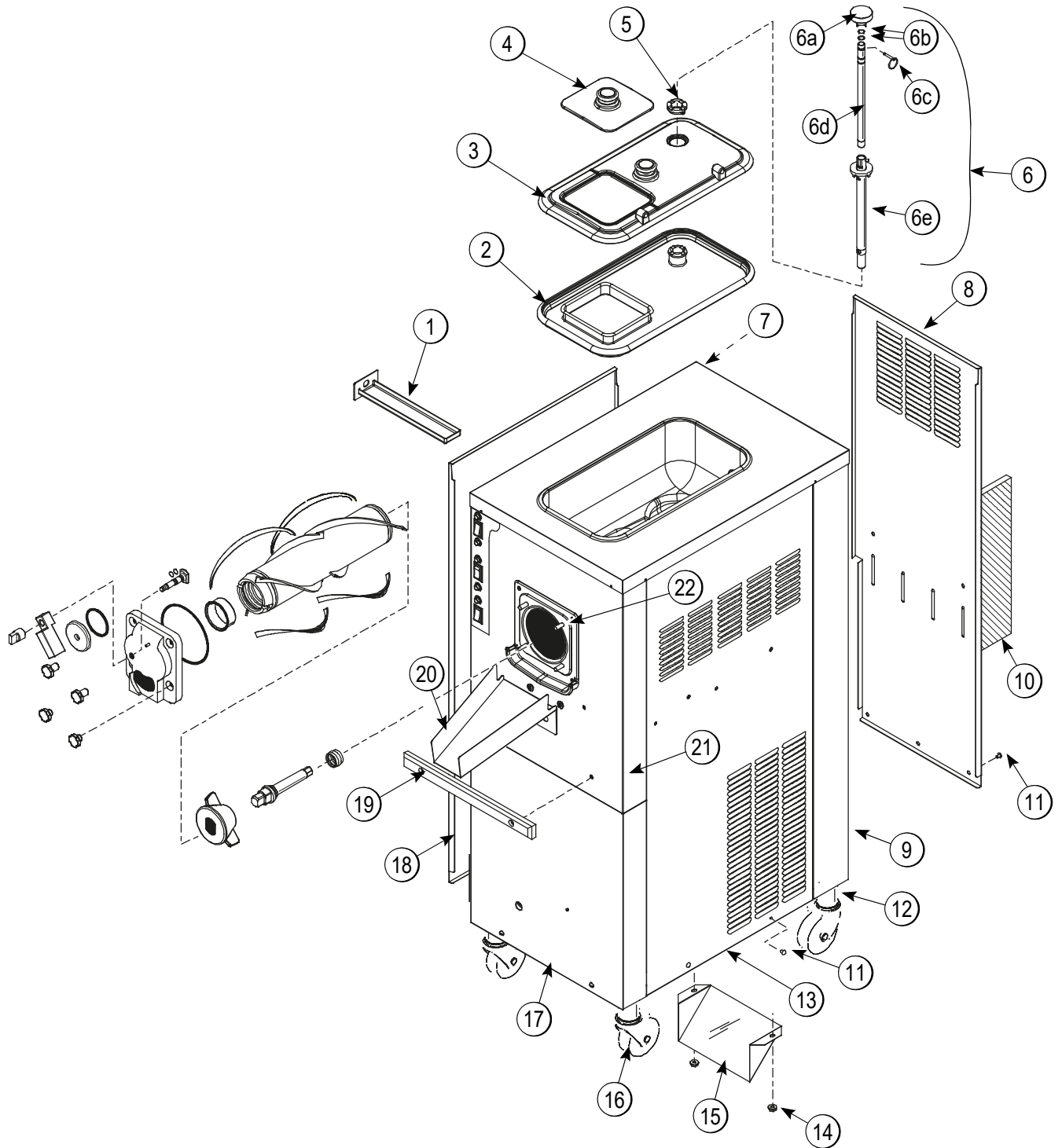

4

Figure 4-1

C001 Exploded View Parts Identification

Item	Description	Part No.
1	Pan-Drip 11-5/8 Long	027503
2	Gasket-Hopper Cover	055356
3	Cover-Hopper-Large	054732
4	Cover-Hopper-Small	054733
5	Bushing-Cover-Hopper	054734
6	Control A.-Flow Reg.	X59788
6a	Knob-Inner-Reg. Tube	059785
6b	O-ring-12.42 mm ID X 1.4 mm	062451
6c	Pin-Quick Release 3/16 X 1 S	027813
6d	Tube-Inner-Regulator	059787
6e	Regulator A.-Flow Outer	059784
7	Trim-Rear Corner L.	067971
8	Panel-Rear	066551
9	Trim-Rear Corner R.	067972
10	Filter-Air-18.00LX13.50HX.70	052779-3

Item	Description	Part No.
11	Screw-1/4-20X3/8 SLTD RND	011694
12	Adaptor A.-Caster	X18915
13	Panel-Side-Right * A/C	067968
14	Nut-10-32 Whiz Flange Locknut	020983
15	Deflector-Blower Exhaust	047912
16	Caster-4" SWV 5/8 Stem w/Brake	034081
17	Panel-Lower Front	066544
18	Panel-Side-Left *A/C	067967
19	Bumper	054487
20	Chute-Custard-Long	054633
*21	Panel A.-Front-Complete	X66542-27
22	Stud-Freezer	034035

*Panel A.-Upper Front (Panel Only) = X66550

4

C002 Exploded View

4

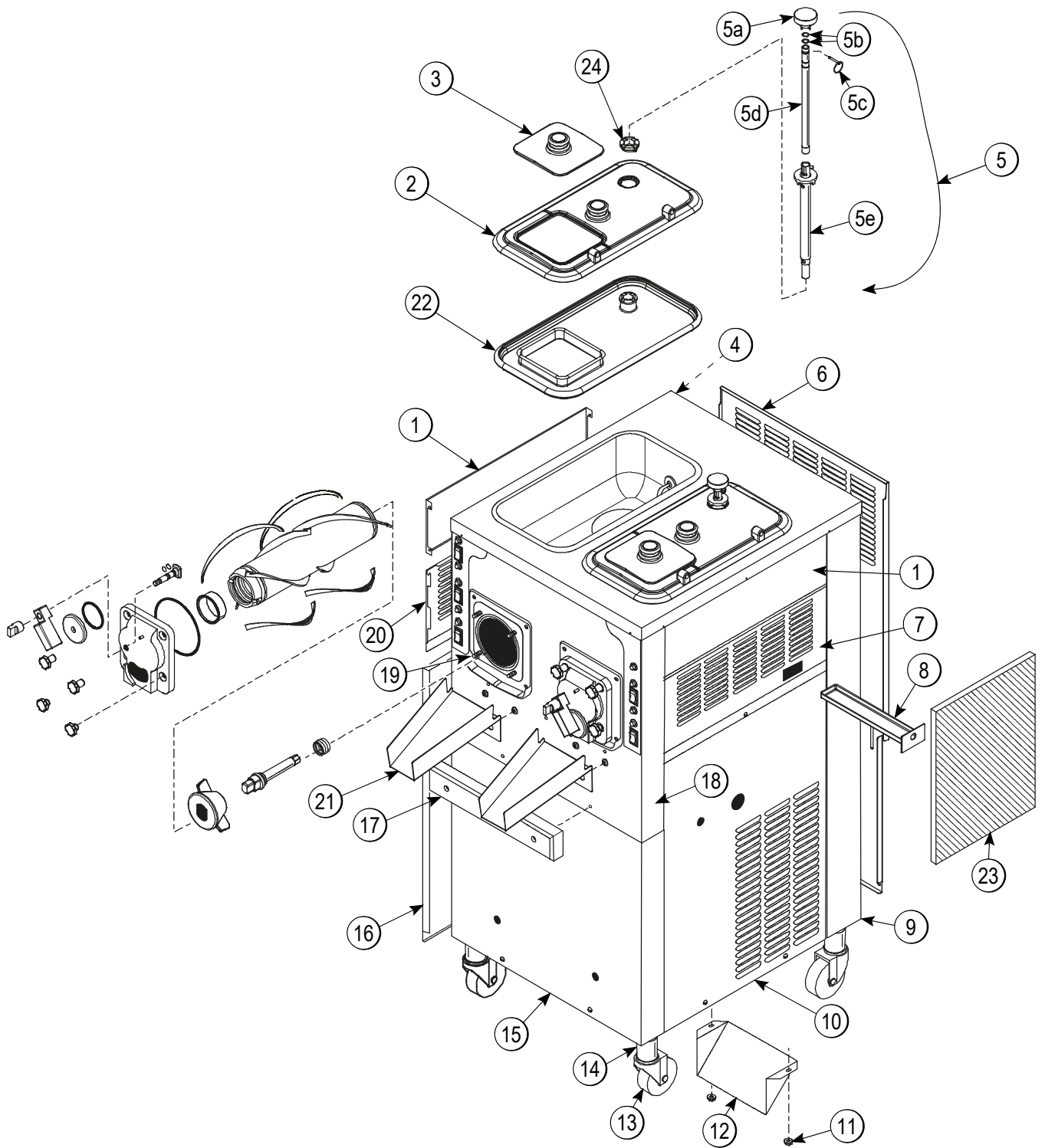

Figure 4-2

C002 Exploded View Parts Identification

Item	Description	Part No.
1	Panel-Side Top	029978
2	Cover-Hopper-Large	054732
3	Cover-Hopper-Small	054733
4	Trim-Rear Corner Left	054458
5	Control A.-Flow Reg.	X59788
5a	Knob-Inner Reg. Tube	059785
5b	O-ring-12.42 ID X 1.4 W	062451
5c	Pin-Quick Release 3/16 X 1	027813
5d	Tube-Inner Regulator	059787
5e	Regulator A.-Flow-Outer	059784
6	Panel-Rear	053782
7	Panel-Upper Side Right	054449
8	Pan-Drip 11-5/8 Long	027503
9	Trim-Rear Corner Right	054459
10	Panel A.-Side Right	X66497
11	Nut-10-32 Whiz Flange Locknut	020983

Item	Description	Part No
12	Deflector-Blower Exhaust	047912
13	Caster-4" SWV 5/8 Stem w/Brake	034081
14	Adaptor-A.-Caster	X18915
15	Panel-Front-Lower	066507
16	Panel A.-Side Left	X66496
17	Bumper-Front	054487
*18	Panel A.-Front-Complete	X66509-27
19	Stud-Freezer	034035
20	Panel-Upper Side Left	054448
21	Chute-Custard-Long	054633
22	Gasket-Hopper Cover	055356
23	Filter-Air 18 L X 13.5 H .70W	052779-3
24	Bushing-Cover-Hopper	054734

*Panel A.-Upper Front (Panel Only) = X66493

4

Dasher (Beater) and Door Assembly

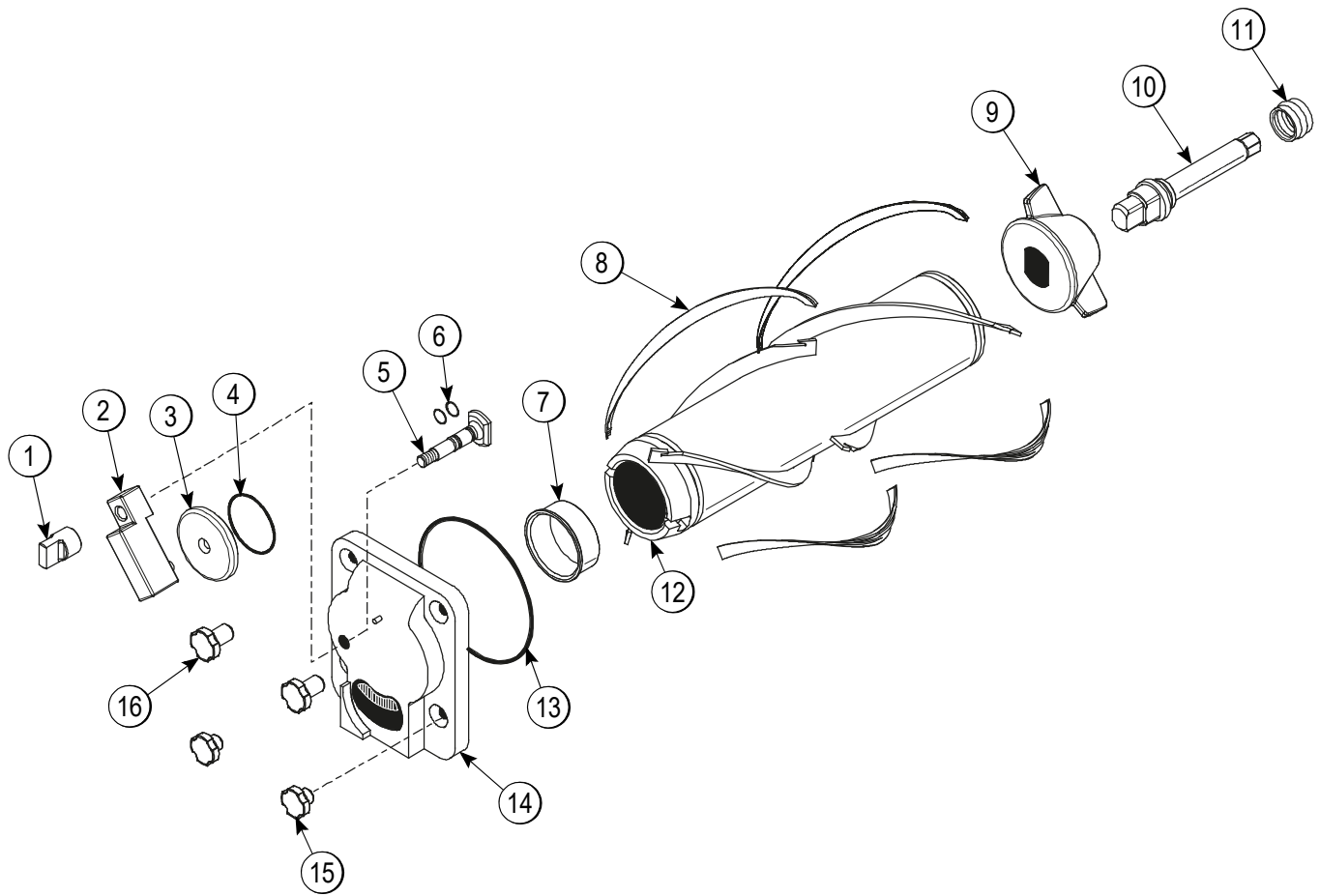

4

Figure 4-3

Item	Description	Part No.
1	Cap-Door-Stem	055179
2	Arm-Handle	055183
3	Plate-Draw	054445
4	O-ring-2-3/4 OD X .139W-70	055182
5	Screw-Door-Stem	055180
6	O-ring-.563 OD X .070W-#013	043758
7	Bearing-Front	013116
8	Blade-Scraper	054485

Item	Description	Part No.
9	Baffle-Short	054481
10	Shaft-Dasher Drive	054484
11	Seal-Driveshaft	032560
12	Dasher A.-Complete	X54483
13	O-ring-6 IN OD X 5 3/4 ID X 1/8	033493
14	Door-C002	X55178-SER
15	Nut-Stud	034034
16	Nut-Stud	021508

Accessories

4

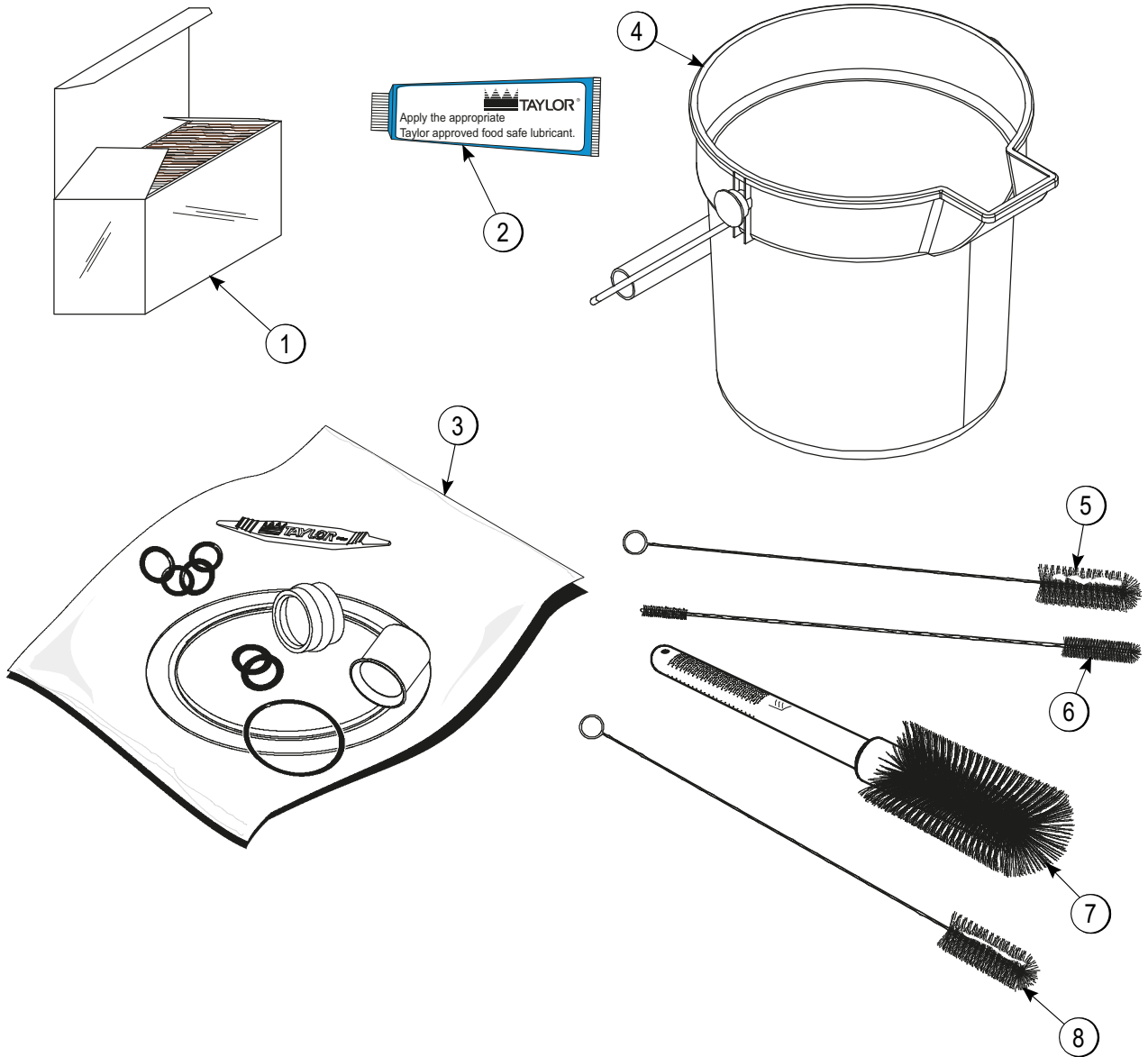
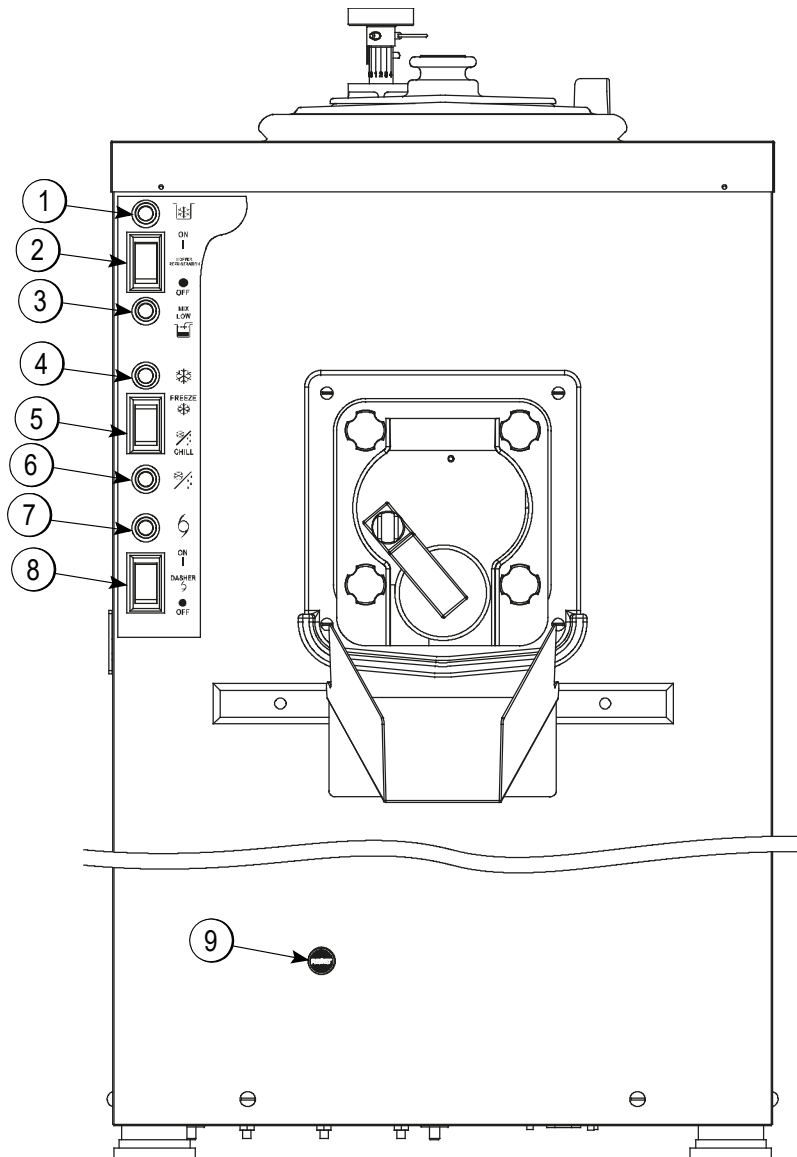

Figure 4-4

Item	Description	Part No.
1	Sanitizer- Stera Sheen	055492
2	Lubricant- Taylor 4 oz.	047518
3	Kit A.- Tune Up	X54630- 1
4	Pail- 10 Qt	013163

Item	Description	Part No.
5	Brush- Rear Bearing	013071
6	Brush- Double Ended	013072
7	Brush- Mix Pump Body	023316
8	Brush- Draw Valve	013073

C001



5

Figure 5-1

Item	Description
1	Light- Hopper Refrigeration
2	Switch- HOPPER REFRIGERATION ON/OFF
3	Light- MIX LOW
4	Light- Freeze Mode
5	Switch- FREEZE/CHILL Mode

Item	Description
6	Light- Chill Mode
7	Light- Dasher
8	Switch- DASHER ON/OFF
9	Button- RESET

C002

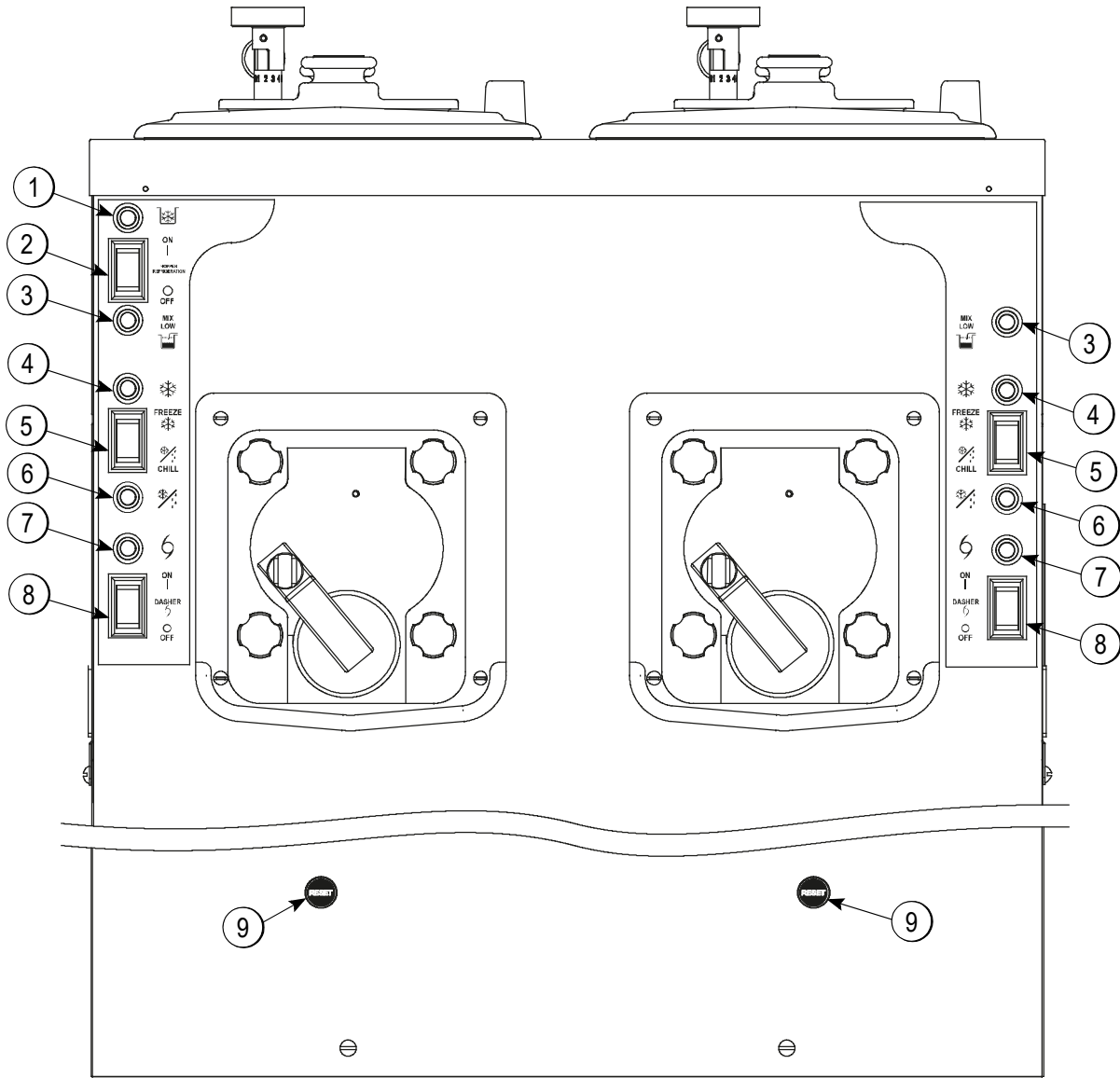

Figure 5-2

Item	Description
1	Light- Hopper Refrigeration
2	Switch- HOPPER REFRIGERATION ON/OFF
3	Light- MIX LOW
4	Light- Freeze Mode
5	Switch- FREEZE/CHILL Mode

Item	Description
6	Light- Chill Mode
7	Light- Dasher
8	Switch- DASHER ON/OFF
9	Button- RESET

Symbol Definitions

To better communicate in the international arena, the words on many of our operator switches and buttons have symbols to indicate their functions. Your Taylor machine is designed with these international symbols.

The following chart identifies the symbol definitions used on the operator switches.

 = HOPPER REFRIGERATION

 = ON

 = OFF

 = MIX LOW

 = FREEZE Mode

 = CHILL Mode

 = DASHER

The Model C001 is a single-flavor custard freezer with a 20 qt. (18.9 L) hopper. The Model C002 is a two-flavor custard freezer with two 20 qt. (18.9 L) hoppers. Mix flows by gravity through an adjustable flow regulator into the freezing cylinder(s). These machines have been designed to produce rich-tasting custard that can be drawn off and served from a dipping cabinet. The overrun is low; typically 15-20%, depending on the mix formulation and the finished product temperature of 17°F to 19°F (-8.3°C to -7.2°C).

The Model C002 has been selected to illustrate the pictured step-by-step operating procedures for both models contained in this manual. These models, for practical purposes of operation, are the same.

We begin our instructions at the point where we find the parts disassembled and laid out to air-dry from the previous brush-cleaning.

The following procedures will show how to assemble the parts into the freezer, sanitize them, and prime the freezer with fresh mix.

If you are disassembling the freezer for the first time or need information to get to this starting point in our instructions, turn to page 6-7, "Disassembly," and start there.

Assembly



WARNING! Make sure the power switch is in the OFF position. Failure to follow this instruction may result in severe personal injury from hazardous moving parts.

1. **Install the driveshaft.** Lubricate the groove and shaft portion that comes in contact with the bearing on the dasher driveshaft. Slide the seal over the shaft and groove until it snaps into place. **Do not** lubricate the hex end of the driveshaft. Fill the inside portion of the seal with 1/4 in. (6 mm) more lubricant and lubricate the flat side of the seal that fits onto the rear shell bearing.

Note: When lubricating parts, always use an approved food grade lubricant (example: Taylor Lube).

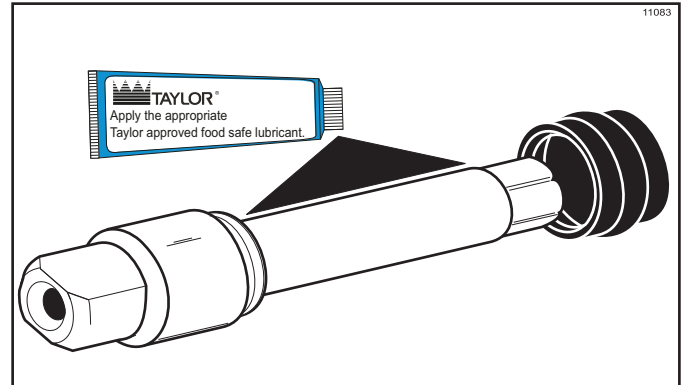

Figure 6-1

Insert the driveshaft into the freezing cylinder, hex end first, and into the rear shell bearing until the seal fits securely over the rear shell bearing. Engage the hex end firmly into the drive coupling. Be sure the driveshaft fits into the drive coupling without binding.

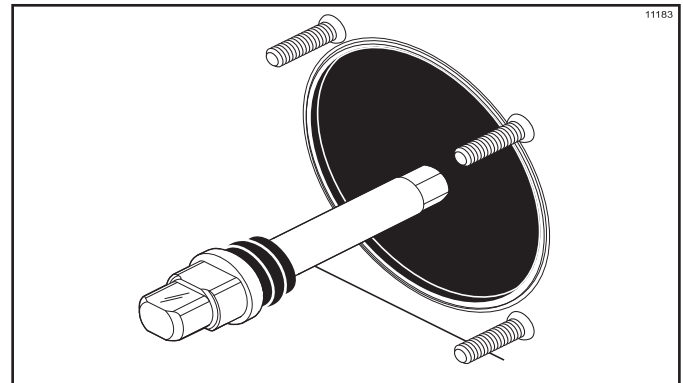

Figure 6-2

2. Install the short baffle into the freezing cylinder, narrow end first. Slide it over the end of the driveshaft.

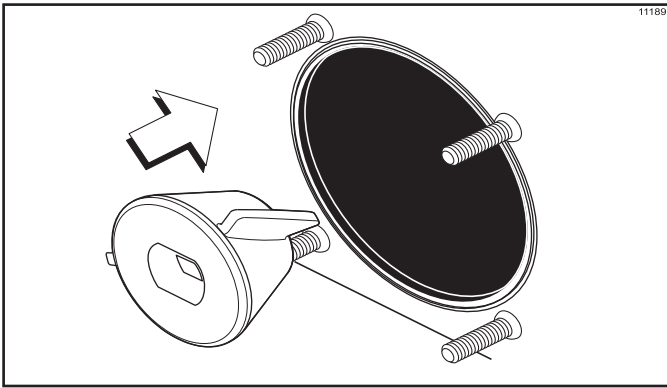

Figure 6-3

3. **Assemble the dasher.** Take one of the scraper blades and slip it under the hook at the front of the dasher. Wrap the blade around the dasher, following the helix and pushing the blade down onto the helix as you wrap. At the back end of the dasher, slip the blade under the hook. **Repeat** this step for the other scraper blades.

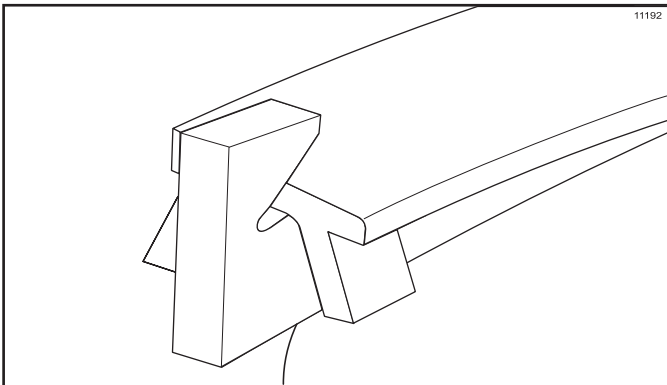

Figure 6-4

4. **Install the dasher.** Slide the dasher into the freezing cylinder and over the end of the driveshaft. The dasher should fit snugly, but not so tightly that the dasher cannot be turned slightly to engage the driveshaft. If the dasher slides in too easily with little or no resistance, there will not be enough force against the dasher to hold the blades in place. If this is the case, contact your authorized Taylor service technician.

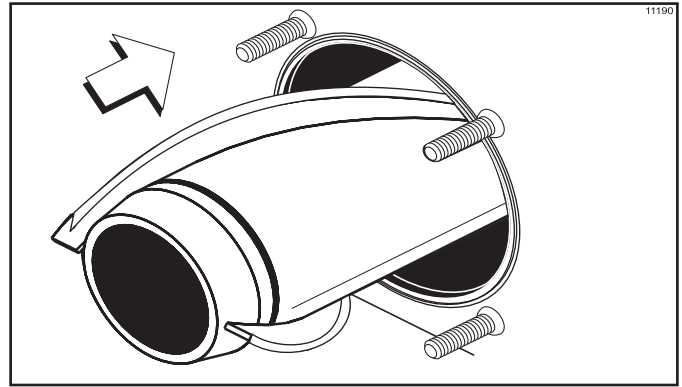

Figure 6-5

Note: A dasher installation/removal tool is available to assist in the installation and removal of the dasher. To install the dasher, insert the short bars of the tool into the slots in the end of the dasher. Using the long bar of the tool, push the dasher until it is properly installed in the freezing cylinder.

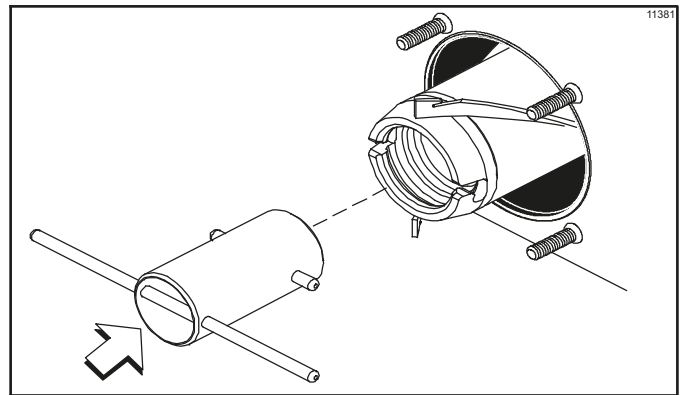

Figure 6-6

Install the front bearing into the front of the dasher assembly.

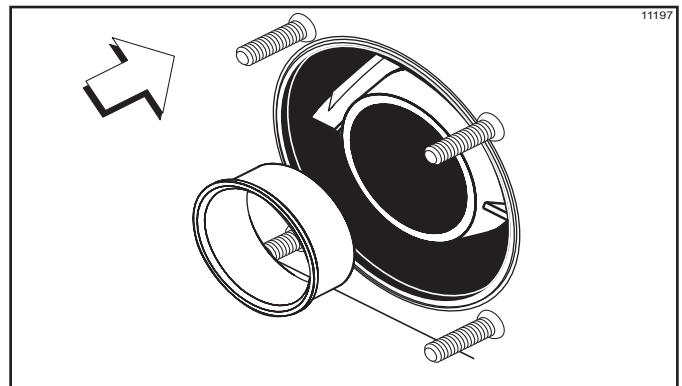

Figure 6-7

5. **Assemble the freezer door.** Install the draw plate O-ring onto the plate and lubricate.

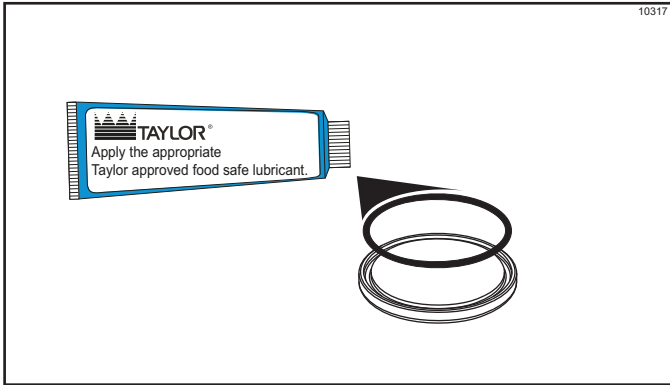

Figure 6-8

Install the two stem screw O-rings onto the stem screw and lubricate.

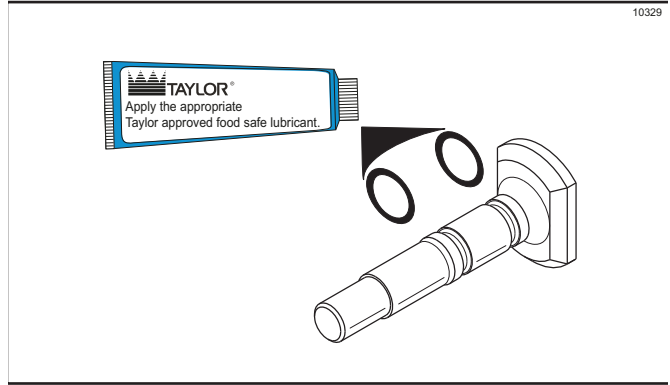

Figure 6-9

Place the stem screw through the back of the door. With the door in a horizontal position, install the draw plate. Align the handle with the stem screw and the draw plate. Hand-tighten the stem cap onto the stem screw.

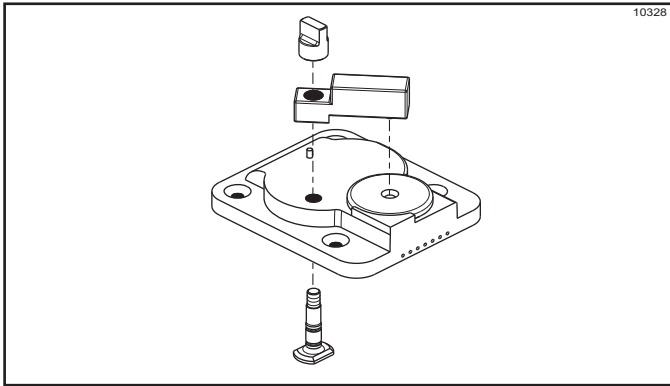

Figure 6-10

Turn the door over and install the large door O-ring. Place a small amount of lubricant on the O-ring, just enough to hold it in place.

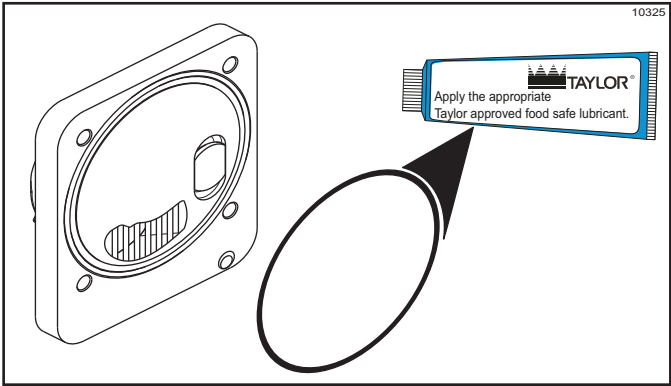

Figure 6-11

6. **Install the freezer door.** Seat the door flush with the freezing cylinder. With the door seated on the freezer studs, install the stud nuts (handscrews). The short stud nuts go on the bottom, and the long stud nuts go on top. Tighten equally in a crisscross pattern to ensure the door is snug.

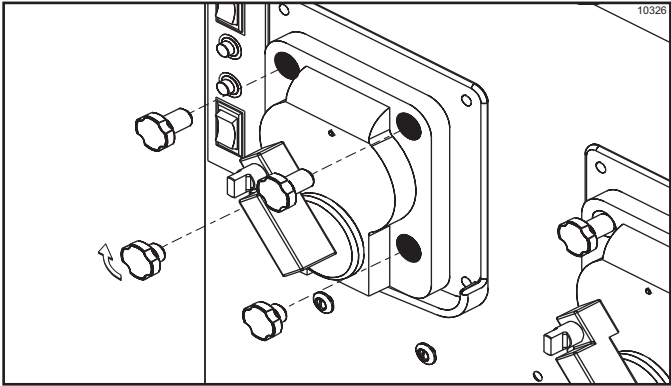

Figure 6-12

7. **Assemble the flow regulator assembly.** Install the two O-rings onto the inner flow regulator. Lubricate the O-rings. Install the knob onto the end of the inner flow regulator and secure it with the quick release pin. Insert the inner flow regulator into the outer flow regulator.

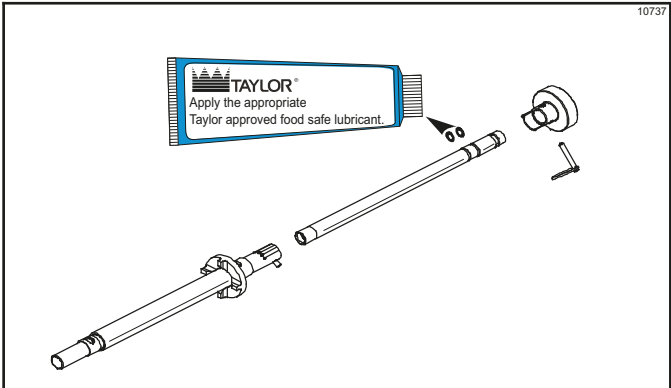

Figure 6-13

OPERATING PROCEDURES

- Place the assembled flow regulator into the hopper for sanitizing.
- Install the rear bearing drip pan.
- Put the sanitized hopper gasket on the hopper cover.

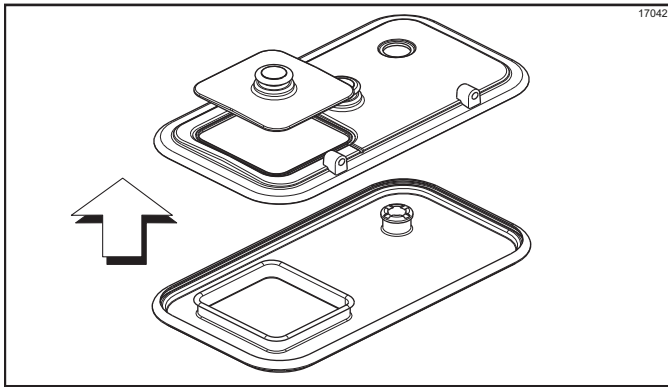

Figure 6-14

Repeat these steps for the other side of the freezer.

Sanitizing

- Prepare an approved 100 ppm sanitizing solution (examples: 2-1/2 gal. [9.5 L] of Kay- 5[®] or 2 gal. [7.6 L] of Stera-Sheen[®]). **Use warm water and follow the manufacturer's specifications.**
- Pour the sanitizing solution into the hopper.
- While the solution is flowing into the freezing cylinder, brush-clean the mix hopper. When cleaning the hopper, take particular care in brushing the mix inlet hole and the flow regulator.
- Place an empty pail under the draw plate. The pail can be hung from the handscrews on the freezer door.
- Place the DASHER switch in the ON position for 5 minutes.
In order to avoid having sanitizer splash out when the draw plate is opened, place the DASHER switch in the OFF position. Open the draw plate and place the DASHER switch in the ON position. Drain the sanitizer into an empty pail. Place the DASHER switch in the OFF position and close the draw plate.



KEEP FINGERS OUT OF FILL AND DISCHARGE OPENINGS. Failure to do so may result in severe personal injury, contaminated product, or component damage.

Repeat these steps for the other side of the freezer.

Priming for Continuous Run

- With sanitized hands**, remove the flow regulator assembly from the mix hopper and set it on a clean, dry surface. Place an empty pail under the draw plate.
- Pour 1 to 2 cups (1/2 L) of mix into the hopper to remove the remaining sanitizing solution from the freezing cylinder.
- Open the draw plate on the freezer door and place the DASHER switch in the ON position.

Repeat steps 1 - 2 for the other side of the freezer.



KEEP FINGERS OUT OF FILL AND DISCHARGE OPENINGS. Failure to do so may result in severe personal injury, contaminated product, or component damage.

- Install the large hopper cover on the hopper.
- With sanitized hands**, install the flow regulator through the hopper cover. Align the flow regulator with the slots on the hopper cover. The flow regulator can be positioned to allow the numbers to be read from the front, back or either side.
- Pour mix into the hopper and fill it to 1/2 in. (13 mm) below the air inlet on the flow regulator.
- Place the FREEZE/CHILL switch in the FREEZE position and the HOPPER REFRIGERATION switch in the ON position.
- Allow the machine to run for 2 minutes. Set the flow regulator between S - 1.
- Install the small hopper lid.

Repeat steps 4 - 9 for the other side of the freezer.

Note: The flow regulator opening is adjustable. The smaller the number, the less product will flow into the freezing cylinder. The larger the number, the more product will flow into the freezing cylinder. The numbers are only guides. The flow regulator may be adjusted to any point in between the numbers.

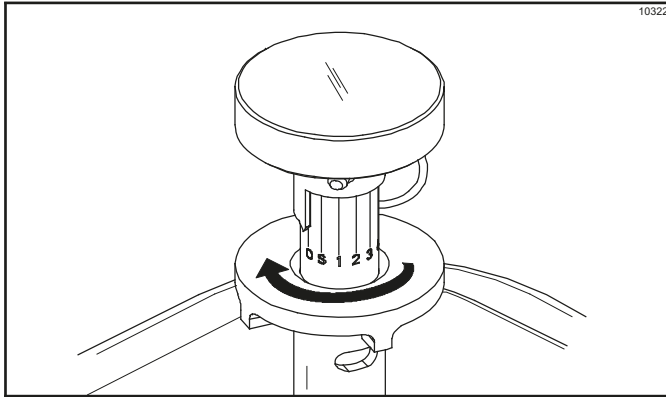

Figure 6-15

10. Install the chute on the two holding collars under the door and position it over the holding cabinet opening.

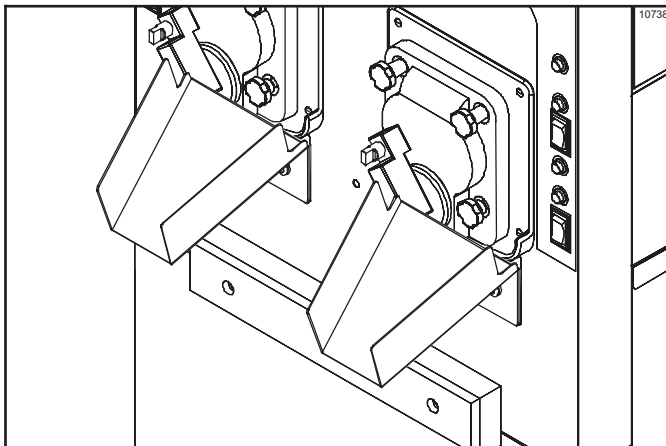

Figure 6-16

11. Leave the draw plate closed until product can be seen coming out around the edges of the draw plate (approximately 3 to 4 minutes) and then open the draw plate all the way.
12. With the draw plate open and a full ribbon of product dispensing at the proper frozen consistency, the flow regulator will need to be opened farther to prevent the freezing cylinder from starving.

Important! If the freezing cylinder becomes starved and begins to make noise, increase the number on the flow regulator. Wait 1 or 2 minutes. If the noise continues, place the FREEZE/CHILL switch in the OFF position until product begins flowing from the door. Place the FREEZE/CHILL switch back in the FREEZE mode position. **Repeat** these steps as necessary to adjust for a specific mix. **Do not turn dasher off.**

If the product becomes too soft, decrease the flow regulator opening.

Repeat steps 10 - 12 for the other side of the freezer.

Stopping a Continuous Run for a Short Period of Time

1. Leave the flow regulator in the Down position, but adjust the setting to 0. Wait 30 seconds.
2. Place the FREEZE/CHILL switch in the CHILL position. Wait 2 minutes.
3. Place the DASHER switch in the OFF position.
4. Close the draw plate.



WARNING: The DASHER motor power switch must be placed in the OFF position when the draw plate is closed. Failure to comply can result in serious equipment damage and possible injury to the operator.

To Restart the Continuous Run:

1. Place the DASHER switch in the ON position.
2. Place the FREEZE/CHILL switch in the FREEZE mode position. Wait one minute.
3. Open the flow regulator back to the previous run setting.
4. Once product starts coming out around the edges of the draw plate, open the draw plate.

Closing Procedure

To disassemble your machine, the following items will be needed:

- Two cleaning pails
- Cleaning brushes (provided with freezer)
- Cleaner
- Single-service towels

Draining Product From the Freezing Cylinder

1. Place the FREEZE/CHILL and the HOPPER REFRIGERATION switches in the OFF position.
2. Remove the flow regulator assembly, hopper covers, gaskets, discharge chute and rear bearing drip pan. Take these parts to the sink for cleaning in an approved cleaning solution (examples: Kay-5[®] or Stera-Sheen[®]).
3. **If local health codes permit the use of rerun**, place a sanitized, NSF-approved stainless-steel rerun container beneath the draw plate. Place the DASHER switch in the ON position. Drain the remaining product into the rerun container. When the flow of product stops, place the DASHER switch in the OFF position. Place the sanitized lid on the rerun container and place it in the walk-in cooler.

Note: *If local health codes do not permit the use of rerun, the product must be discarded. Follow the instructions in the previous step, except drain the product into a pail and properly discard the mix.*

Repeat steps 1 through 3 for the other side of the freezer.



Rinsing

1. With a pail beneath the draw plate, pour 2 gal. (7.6 L) of **cool**, clean water into the mix hopper. With the brushes provided, scrub the mix hopper.

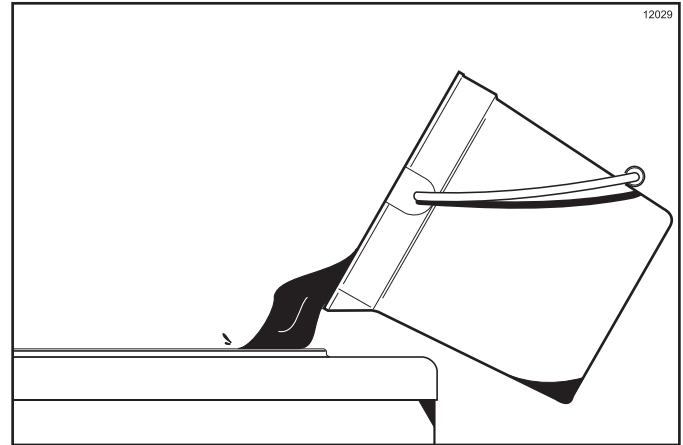

Figure 6-17

2. Place the DASHER switch in the ON position. Agitate for 5 minutes. Drain all the rinse water from the freezing cylinder.

Repeat steps 1 through 2 until the water is clear.

3. Once all the rinse water has drained, place the DASHER switch in the OFF position.

Repeat steps 1 through 3 for the other side of the freezer.

Cleaning

1. Prepare an approved **100 ppm** cleaning solution (examples: 2-1/2 gal. [9.5 L] of Kay-5[®] or 2 gal. [7.6 L] of Stera-Sheen[®]). **Use warm water and follow the manufacturer's specifications.**
2. With the draw plate closed, pour the cleaning solution into the mix hopper.

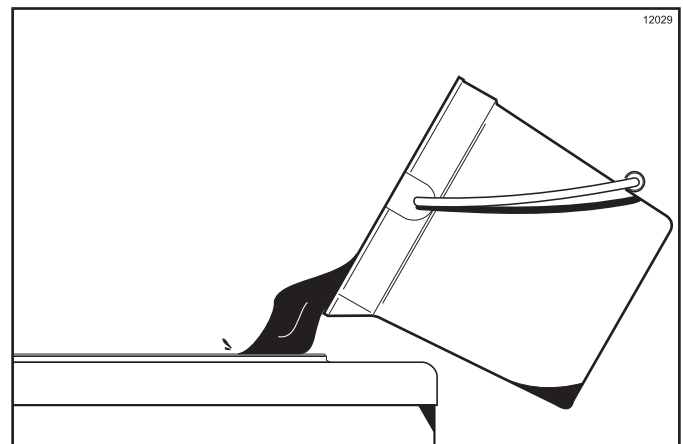

Figure 6-18

3. While the solution is flowing into the freezing cylinder, brush-clean the mix hopper.
4. Place an empty pail beneath the draw plate.
5. Place the DASHER switch in the ON position.
6. Allow all of the solution to drain.

Repeat steps 1 through 6 for the other side of the freezer.

Disassembly



WARNING! Make sure the power switch is in the OFF position. Failure to follow this instruction may result in severe personal injury from hazardous moving parts.

1. Remove the flow regulators from the mix hoppers. Remove the handscrews, freezer doors, dashers, scraper blades, chutes, and driveshafts from the freezing cylinders. Take these parts to the sink for cleaning.

Note: A dasher installation/removal tool is available to assist in the installation and removal of the dasher. To remove the dasher, insert the two short bars of the tool into the slots in the end of the dasher. Holding the long bar of the tool, turn the tool clockwise to lock the tool in the dasher, and then pull the dasher out.

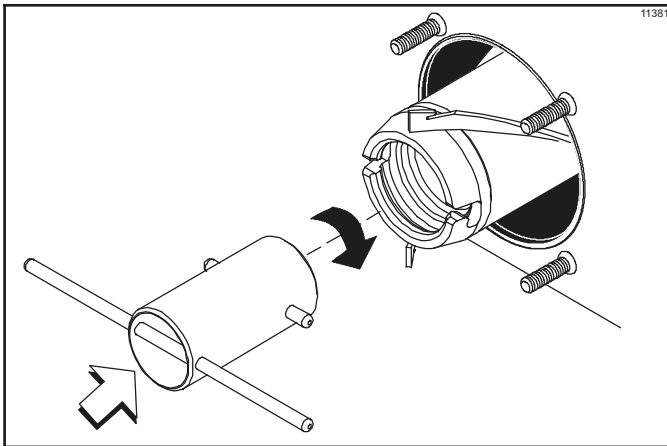

Figure 6-19

Brush-Cleaning

1. Prepare a sink with an approved cleaning solution (examples: Kay-5[®] or Stera-Sheen[®]). **Use warm water and follow the manufacturer's specifications.** If another approved cleaner is used, dilute it according to the label instructions. (**Important!** Follow the label directions. *Too strong of a solution can cause parts damage, while too mild of a solution will not provide adequate cleaning.*) Make sure all brushes provided with the freezer are available for brush-cleaning.
2. Remove the seals from the driveshafts.

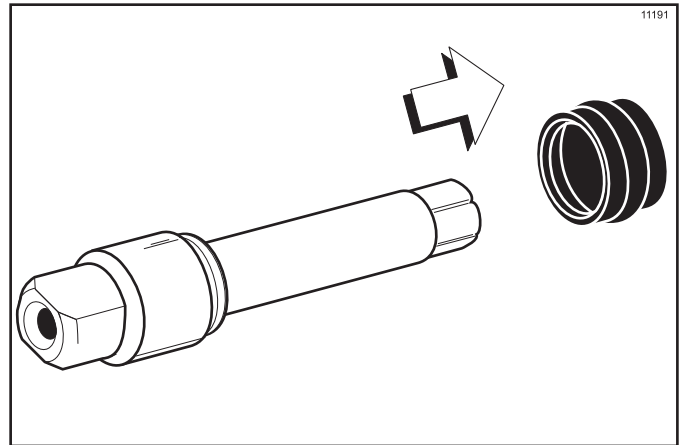

Figure 6-20

3. From the freezer door remove:
 - Front bearings
 - Handle arms
 - Plates
 - Stem caps
 - Stem screws
4. Remove all O-rings.

Note: To remove O-rings, use a single-service towel to grasp the O-ring. Apply pressure upward until the O-ring pops out of its groove. With the other hand, push the top of the O-ring forward. It will roll out of the groove and can be easily removed. If there is more than one O-ring to be removed, always remove the rear O-ring first. This will allow the O-ring to slide over the forward rings without falling into the open grooves.

OPERATING PROCEDURES

5. Remove the O-rings from the inner flow regulators.

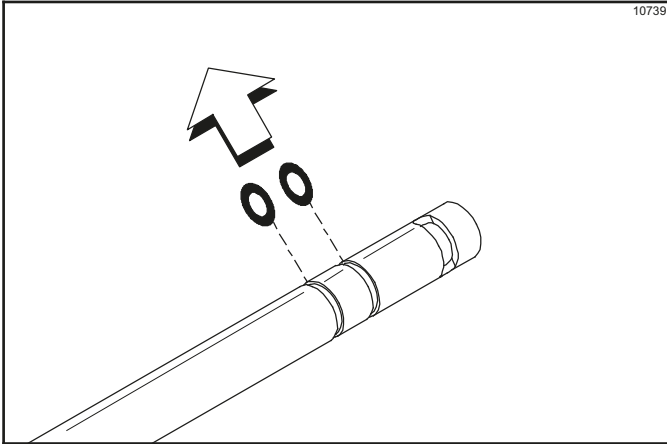

Figure 6-21

6. Remove the hopper cover gasket from the hopper cover.
7. Return to the freezer with a small amount of cleaning solution. Brush-clean the mix inlet holes in the mix hoppers.

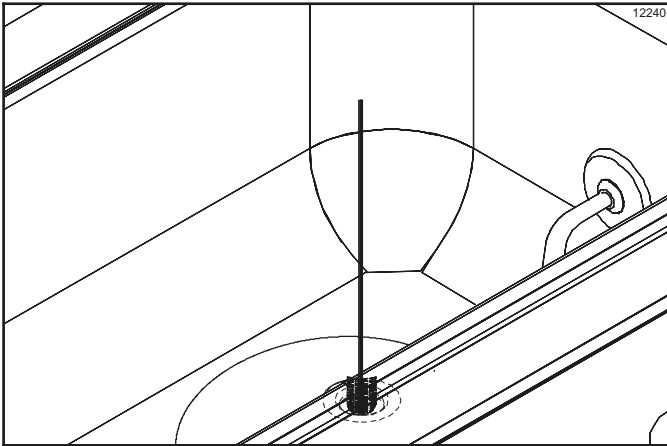

Figure 6-22

8. Brush-clean the rear shell bearings at the back of the freezing cylinders with the black bristle brush.

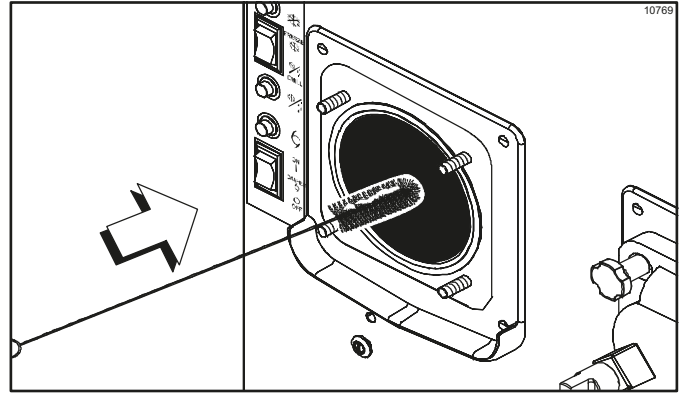

Figure 6-23

9. Thoroughly brush-clean all disassembled parts in the cleaning solution, making sure all lubricant and mix film is removed. Place all the cleaned parts on a clean, dry surface to air-dry overnight.
10. Wipe clean all exterior surfaces of the freezer.

6

During Cleaning and Sanitizing



ALWAYS FOLLOW LOCAL HEALTH CODES.



NOTICE! Cleaning and sanitizing schedules are governed by your federal, state, or local regulatory agencies and must be followed accordingly. Please see the cleaning section of this manual for the proper procedure to clean this machine.

If the machine has a Standby mode, it must not be used instead of proper cleaning and sanitizing procedures and frequencies set forth by the ruling health authority. The following checkpoints should be stressed during the cleaning and sanitizing operations.



IMPORTANT! Cleaning and sanitizing must be performed daily.

Troubleshooting Bacterial Count

- If local health codes permit the use of rerun, make sure the mix rerun is stored in a sanitized, covered stainless-steel container and used the following day. **Do not prime the machine with rerun.** When using rerun, skim off the foam and discard. Mix the rerun with fresh mix in a ratio of 50:50 during the day's operation.
 - On a designated day of the week, run the mix as low as feasible and discard it after closing. This will break the rerun cycle and reduce the possibility of high bacteria and coliform counts.
 - Properly prepare the cleaning and sanitizing solutions. Read and follow the label directions carefully. Too **strong** of a solution may damage the parts, and too **weak** of a solution will not do an adequate job of cleaning or sanitizing.
 - The temperature of the mix in the mix hopper and walk-in cooler should be below 40°F (4.4°C).
- Thoroughly clean and sanitize the machine regularly, including complete disassembly and brush-cleaning.
 - Use all brushes supplied for thorough cleaning. The brushes are specially designed to reach all mix passageways.
 - Use the white bristle brush to clean the mix inlet hole, which extends from the mix hopper down to the rear of the freezing cylinder.
 - Use the black bristle brush to thoroughly clean the rear shell bearing at the rear of the freezing cylinder. Be sure there is a generous amount of cleaning solution on the brush.

Regular Maintenance Checks

- Replace scraper blades that are nicked or damaged. Before installing the dasher assembly, be certain that the scraper blades are properly attached to the dasher shaft.
- Check the rear shell bearing for signs of wear (excessive mix leakage in rear drip pan) and be certain it is properly cleaned.
- Using a long brush and a cloth towel, clean the rear shell bearing and the female hex drive socket of lubricant and mix deposits.
- Dispose of O-rings and seals if they are worn, torn, or fit too loosely, and replace them with new ones.
- Follow all lubricating procedures as outlined in Assembly on page 6-1.
- If your machine is air-cooled, check the condenser for dirt and lint. Dirty condensers will reduce the efficiency and capacity of the machine. Condensers should be cleaned **monthly** with a soft brush. **Do not** use screwdrivers or other metal probes to clean between the fins.

Note: For machines equipped with an air filter, it will be necessary to vacuum-clean the filters monthly.



7 **Caution: Always disconnect electrical power prior to cleaning the condenser.** Failure to follow this instruction may result in electrocution.

- If your machine is water-cooled, check the water lines for kinks or leaks. Kinks can occur when the machine is moved back and forth for cleaning or maintenance. Deteriorated or cracked water lines should be replaced only by an authorized Taylor distributor.

Winter Storage

If the place of business is to be closed during the winter months, it is important to protect the freezer by following certain precautions, particularly if the building is subject to freezing conditions.

Disconnect the freezer from the main power source to prevent possible electrical damage.

On water-cooled freezers, disconnect the water supply. Relieve pressure on the spring in the water valve. Use air pressure on the outlet side to blow out any water remaining in the condenser. **This is extremely important.** Failure to follow this procedure may cause severe and costly damage to the refrigeration system.

Your local Taylor distributor can perform this winter storage service for you.

Wrap detachable parts of the freezer such as dasher, blades, dasher shaft, and freezer door, and place them in a protected dry place. Rubber trim parts and gaskets can be protected by wrapping them with moisture-proof paper. All parts should be thoroughly cleaned of dried mix or lubrication, which can attract mice and other vermin.

It is recommended that a service technician perform winter storage draining to ensure all water has been removed. This will guard against freezing and rupturing of the components.

Table 8-1

Problem	Probable Cause	Remedy	Page Ref.
1. Compressor will not run.	a. DASHER switch and/or FREEZE/CHILL switch are in the wrong position.	a. Place the DASHER switch and/or the FREEZE/CHILL switch in the FREEZE position.	5-2
	b. The contactor is faulty.	b. Call a service technician.	---
	c. Compressor has burned out.	c. Call a service technician.	---
	d. The fuse or circuit breaker has blown.	d. Replace fuse/turn on breaker.	1-2
	e. Tripped overload (compressor).	e. Place the power switch to OFF. Allow compressor to cool and the overload to close before returning the power switch to ON.	---
	f. Freezer door is off.	f. Install the freezer door.	6-3
2. Head pressure is too high.	a. Condenser is dirty.	a. Clean the condenser.	7-2
	b. Refrigerant overcharge.	b. Call a service technician.	---
	c. Fan is faulty.	c. Call a service technician.	---
3. Head pressure is too low.	a. Shortage of refrigerant.	a. Call a service technician.	---
4. Liquid line is hot.	a. Shortage of refrigerant.	a. Call a service technician.	---
5. Excessive mix leakage through the rear of the machine into the drip pan.	a. Worn or missing driveshaft seal.	a. Replace worn, nicked or missing driveshaft seal.	6-1
	b. Inadequate lubrication.	b. Lubricate properly.	6-1
6. Product is not being fed into the freezing cylinder.	a. Inadequate mix in hopper. (Mix Out light illuminated)	a. Fill hopper with mix.	6-4
	b. Incorrect usage of the mix flow regulator.	b. Follow the correct flow regulator adjustment procedures.	6-4
7. No product is being dispensed with the flow control open.	a. Frozen product.	a. Scrape product away from the door.	---
	b. Dasher is rotating counterclockwise.	b. Call a service technician.	---
	c. Inadequate mix in hopper. (Mix Out light illuminated)	c. Fill hopper with mix.	6-4
	d. Flow regulator is plugged.	d. Brush-clean the flow regulator.	6-7
8. Product is too soft.	a. Bad scraper blades.	a. Replace scraper blades.	6-1, 7-2
	b. Dirty condenser (air-cooled).	b. Clean condenser monthly.	7-2
	c. Mix is outdated.	c. Use fresh mix.	---
	d. Refrigerant shortage.	d. Call a service technician.	---
	e. Flow regulator setting is too high.	e. Call a service technician.	---
9. Door spout is plugged.	a. Poor scraping.	a. Replace scraper blades.	6-1, 7-2
	b. The dasher assembly is damaged.	b. Inspect and replace if necessary.	6-1, 7-2
10. No freezer operation when machine is placed in any mode of operation.	a. The machine is unplugged.	a. Plug in the machine.	---
	b. Circuit breaker is off or fuse is blown.	b. Turn on the circuit breaker/replace fuse.	---

TROUBLESHOOTING GUIDE

Problem	Probable Cause	Remedy	Page Ref.
11.Product is too stiff.	a. Flow regulator is set too low.	a. Adjust the flow regulator setting.	6-4
	b. Flow regulator is incorrectly assembled or is malfunctioning.	b. Re- assemble the flow regulator. If flow regulator malfunctions, call a service technician.	6-4
12.The mix in the hopper is too cold.	a. Temperature is out of adjustment.	a. Call a service technician.	---
13.The mix in the hopper is too warm.	a. Temperature is out of adjustment.	a. Call a service technician.	---
14.Driveshaft is stuck in the gear box coupling.	a. The corners of the driveshaft, coupling, or both are rounded.	a. Replace the necessary component(s). Do not lubricate the end of the driveshaft.	6-1
	b. Mix and lubricant have collected in the drive coupling.	b. Brush-clean the rear shell bearing area regularly.	6-7
15.Freezing cylinder walls are scored.	a. The dasher assembly is damaged.	a. Replace the dasher assembly.	6-1, 7-2
	b. The front bearing is either missing or is worn.	b. Install/replace front bearing.	6-1, 7-2
16.A chirping or squealing sound is coming from the freezing cylinder.	a. The freezing cylinder is starved for mix.	a. Adjust the flow control to allow more mix to enter the freezing cylinder.	6-4
17.The reset is tripping.	a. The belt is too tight.	a. Call a service technician.	---
	b. The amperage is too high.	b. Call a service technician.	---
	c. The dasher is rotating counterclockwise.	c. Call a service technician.	---
	d. Faulty reset switch.	d. Call a service technician.	---
	e. The suction pressure is too low.	e. Call a service technician.	---
	f. The shaft is too far into the gearbox or is pushing on the door.	f. Call a service technician.	---
	g. Product is frozen in the freezing cylinder.	g. Call a service technician.	---

Table 9-1

Part Description	Every 3 Months	Every 6 Months	Annually
Front Bearing	X		
Inner Flow Regulator O-rings	X		
Draw Plate O-ring	X		
Freezer Door O-ring	X		
Driveshaft Seal	X		
Scraper Blades	X		
Black Bristle Brush - 1" x 2"		Inspect and replace if necessary.	Minimum
Double Ended Brush		Inspect and replace if necessary.	Minimum
White Bristle Brush - 3" x 7"		Inspect and replace if necessary.	Minimum

TAYLOR COMPANY LIMITED WARRANTY ON FREEZERS

Taylor Company is pleased to provide this limited warranty on new Taylor-branded freezer machines available from Taylor to the market generally (the "Product") to the original purchaser only.

LIMITED WARRANTY

Taylor warrants the Product against failure due to defect in materials or workmanship under normal use and service as follows. All warranty periods begin on the date of original Product installation. If a part fails due to defect during the applicable warranty period, Taylor, through an authorized Taylor distributor or service agency, will provide a new or remanufactured part, at Taylor's option, to replace the failed defective part at no charge for the part. Except as otherwise stated herein, these are Taylor's exclusive obligations under this limited warranty for a Product failure. This limited warranty is subject to all provisions, conditions, limitations, and exclusions listed below and on the reverse (if any) of this document.

Table 10-1

Product	Part	Limited Warranty Period
Soft Serve	Insulated Shell Assembly	Five (5) Years
Frozen Yogurt Shakes	Refrigeration Compressor (except service valve)	Five (5) Years
Smoothies	Beater Motors	Two (2) Years
Frozen Beverage	Beater Drive Gear	Two (2) Years
Batch Desserts	Printed circuit boards and Softech controls beginning with serial number H8024200	Two (2) Years
	Parts Not Otherwise Listed in This Table or Excluded Below	One (1) Years

LIMITED WARRANTY CONDITIONS

1. If the date of original installation of the Product cannot be verified, then the limited warranty period begins ninety (90) days from the date of Product manufacture (as indicated by the Product serial number). Proof of purchase may be required at time of service.
2. This limited warranty is valid only if the Product is installed and all required service work on the Product is performed by a Taylor-authorized distributor or service agency, and only if genuine, new Taylor parts are used.
3. Installation, use, care, and maintenance must be normal and in accordance with all instructions contained in the Taylor Operator's Manual.
4. Defective parts must be returned to the Taylor-authorized distributor or service agency for credit.
5. The use of any refrigerant other than that specified on the Product's data label will void this limited warranty.

LIMITED WARRANTY ON MACHINES

LIMITED WARRANTY EXCEPTIONS

This limited warranty does **not** cover:

1. Labor or other costs incurred for diagnosing, repairing, removing, installing, shipping, servicing, or handling of defective parts, replacement parts, or new Products.
2. Normal maintenance, cleaning, and lubrication as outlined in the Taylor Operator's Manual, including cleaning of condensers.
3. Replacement of wear items designated as Class "000" parts in the Taylor Operator's Manual.
4. External hoses, electrical power supplies, and machine grounding.
5. Parts not supplied or designated by Taylor, or damages resulting from their use.
6. Return trips or waiting time required because a service technician is prevented from beginning warranty service work promptly upon arrival.
7. Failure, damage, or repairs due to faulty installation, misapplication, abuse, no or improper servicing, unauthorized alteration, or improper operation or use as indicated in the Taylor Operator's Manual, including but not limited to the failure to use proper assembly and cleaning techniques, tools, or approved cleaning supplies.
8. Failure, damage, or repairs due to theft, vandalism, wind, rain, flood, high water, water, lightning, earthquake, or any other natural disaster, fire, corrosive environments, insect or rodent infestation, or other casualty, accident, or condition beyond the reasonable control of Taylor; operation above or below the electrical or water supply specification of the Product; components repaired or altered in any way so as to, in the judgment of the Manufacturer, adversely affect performance, or normal wear or deterioration.
9. Any Product purchased over the Internet.
10. Failure to start due to voltage conditions, blown fuses, open circuit breakers, or damages due to the inadequacy or interruption of electrical service.
11. Electricity or fuel costs, or increases in electricity or fuel costs for any reason whatsoever.
12. Damages resulting from the use of any refrigerant other than that specified on the Product's data label will void this limited warranty.
13. Any cost to replace, refill, or dispose of refrigerant, including the cost of refrigerant.
14. **ANY SPECIAL, INDIRECT, OR CONSEQUENTIAL PROPERTY OR COMMERCIAL DAMAGE OF ANY NATURE WHATSOEVER.** Some jurisdictions do not allow the exclusion of incidental or consequential damages, so this limitation may not apply to you.

This limited warranty gives you specific legal rights, and you may also have other rights that vary from jurisdiction to jurisdiction.

LIMITATION OF WARRANTY

THIS LIMITED WARRANTY IS EXCLUSIVE AND IS IN LIEU OF ALL OTHER WARRANTIES, CONDITIONS, AND/OR REMEDIES UNDER THE LAW, INCLUDING ANY IMPLIED WARRANTIES OR CONDITIONS OF MERCHANTABILITY OR FITNESS FOR A PARTICULAR PURPOSE. THE ORIGINAL OWNER'S SOLE REMEDY WITH RESPECT TO ANY PRODUCTS SHALL BE REPAIR OR REPLACEMENT OF DEFECTIVE COMPONENTS UNDER THE TERMS OF THIS LIMITED WARRANTY. ALL RIGHTS TO CONSEQUENTIAL OR INCIDENTAL DAMAGES (INCLUDING CLAIMS FOR LOST SALES, LOST PROFITS, PRODUCT LOSS, PROPERTY DAMAGES, OR SERVICE EXPENSES) ARE EXPRESSLY EXCLUDED. THE EXPRESS WARRANTIES MADE IN THIS LIMITED WARRANTY MAY NOT BE ALTERED, ENLARGED, OR CHANGED BY ANY DISTRIBUTOR, DEALER, OR OTHER PERSON, WHATSOEVER.

LEGAL REMEDIES

The owner **must** notify Taylor in writing by certified or registered letter to the following address, of any defect or complaint with the Product, stating the defect or complaint and a specific request for repair, replacement, or other correction of the Product under warranty, mailed at least thirty (30) days before pursuing any legal rights or remedies.

Taylor Company
750 N. Blackhawk Blvd.
Rockton, IL 61072, U.S.A.

TAYLOR COMPANY LIMITED WARRANTY ON TAYLOR GENUINE PARTS

Taylor Company is pleased to provide this limited warranty on new Taylor genuine replacement components and parts available from Taylor to the market generally (the “Parts”) to the original purchaser only.

LIMITED WARRANTY

Taylor warrants the Parts against failure due to defect in materials or workmanship under normal use and service as follows. All warranty periods begin on the date of original installation of the Part in the Taylor machine. If a Part fails due to defect during the applicable warranty period, Taylor, through an authorized Taylor distributor or service agency, will provide a new or remanufactured Part, at Taylor’s option, to replace the failed defective Part at no charge for the Part. Except as otherwise stated herein, these are Taylor’s exclusive obligations under this limited warranty for a Part failure. This limited warranty is subject to all provisions, conditions, limitations, and exclusions listed below and on the reverse (if any) of this document.

Table 11-1

Parts Warranty Class Code or Part	Limited Warranty Period
Class 103 Parts ¹	Three (3) Months
Class 212 Parts ²	Twelve (12) Months
Class 512 Parts	Twelve (12) Months
Class 000 Parts	No Warranty

LIMITED WARRANTY CONDITIONS

1. If the date of original installation of the Part cannot be otherwise verified, proof of purchase may be required at time of service.
2. This limited warranty is valid only if the Part is installed and all required service work in connection with the Part is performed by a Taylor-authorized distributor or service agency.
3. The limited warranty applies only to Parts remaining in use by their original owner at their original installation location in the machine of original installation.
4. Installation, use, care, and maintenance must be normal and in accordance with all instructions contained in the Taylor Operator’s Manual.
5. Defective Parts must be returned to the authorized Taylor distributor or service agency for credit.
6. This warranty is not intended to shorten the length of any warranty coverage provided pursuant to a separate Taylor Limited Warranty on freezer or grill machines.
7. The use of any refrigerant other than that specified for the machine in which the Part is installed will void this limited warranty.

^{1,2} Except that Taylor Part #032129SER2 (Compressor-Air-230V SERV) and Taylor Part #075506SER1 (Compressor-Air-115V 60HZ) shall have a limited warranty period of twelve (12) months when used in Taylor freezer machines and a limited warranty period of two (2) years when used in Taylor grill machines.

LIMITED WARRANTY ON PARTS

LIMITED WARRANTY EXCEPTIONS

This limited warranty does **not** cover:

1. Labor or other costs incurred for diagnosing, repairing, removing, installing, shipping, servicing, or handling of defective Parts, replacement Parts, or new Parts.
2. Normal maintenance, cleaning, and lubrication as outlined in the Taylor Operator's Manual, including cleaning of condensers or carbon and grease buildup.
3. Required service, whether cleaning or general repairs, to return the cooking surface assemblies, including the upper platen and lower plate, to an operational condition to achieve proper cooking or allow proper assembly of release sheets and clips as a result of grease buildup on the cooking surfaces, including but not limited to the platen and plate, sides of the shroud, or top of the shroud.
4. Replacement of cooking surfaces, including the upper platen and lower plate, due to pitting or corrosion (or in the case of the upper platen, due to loss of plating) as a result of damage due to the impact of spatulas or other small wares used during the cooking process or as a result of the use of cleaners, cleaning materials, or cleaning processes not approved for use by Taylor.
5. Replacement of wear items designated as Class "000" Parts in the Taylor Operator's Manual, as well as any release sheets and clips for the Product's upper platen assembly.
6. External hoses, electrical power supplies, and machine grounding.
7. Parts not supplied or designated by Taylor, or damages resulting from their use.
8. Return trips or waiting time required because a service technician is prevented from beginning warranty service work promptly upon arrival.
9. Failure, damage, or repairs due to faulty installation, misapplication, abuse, no or improper servicing, unauthorized alteration, or improper operation or use as indicated in the Taylor Operator's Manual, including but not limited to the failure to use proper assembly and cleaning techniques, tools, or approved cleaning supplies.
10. Failure, damage, or repairs due to theft, vandalism, wind, rain, flood, high water, water, lightning, earthquake, or any other natural disaster, fire, corrosive environments, insect or rodent infestation, or other casualty, accident or condition beyond the reasonable control of Taylor; operation above or below the gas, electrical or water supply specification of the machine in which a part is installed; or Parts or the machines in which they are installed repaired or altered in any way so as to, in the judgment of Taylor, adversely affect performance, or normal wear or deterioration.
11. Any Part purchased over the Internet.
12. Failure to start due to voltage conditions, blown fuses, open circuit breakers, or damages due to the inadequacy or interruption of electrical service.
13. Electricity, gas, or other fuel costs, or increases in electricity or fuel costs for any reason whatsoever.
14. Damages resulting from the use of any refrigerant other than that specified for the machine in which the Part is installed will void this limited warranty.
15. Any cost to replace, refill, or dispose of refrigerant, including the cost of refrigerant.
16. **ANY SPECIAL, INDIRECT, OR CONSEQUENTIAL PROPERTY OR COMMERCIAL DAMAGE OF ANY NATURE WHATSOEVER.** Some jurisdictions do not allow the exclusion of incidental or consequential damages, so this limitation may not apply to you.

This limited warranty gives you specific legal rights, and you may also have other rights which vary from jurisdiction to jurisdiction.

LIMITATION OF WARRANTY

THIS LIMITED WARRANTY IS EXCLUSIVE AND IS IN LIEU OF ALL OTHER WARRANTIES, CONDITIONS, AND/OR REMEDIES UNDER THE LAW, INCLUDING ANY IMPLIED WARRANTIES OR CONDITIONS OF MERCHANTABILITY OR FITNESS FOR A PARTICULAR PURPOSE. THE ORIGINAL OWNER'S SOLE REMEDY WITH RESPECT TO ANY PRODUCTS SHALL BE REPAIR OR REPLACEMENT OF DEFECTIVE PARTS UNDER THE TERMS OF THIS LIMITED WARRANTY. ALL RIGHTS TO CONSEQUENTIAL OR INCIDENTAL DAMAGES, (INCLUDING CLAIMS FOR LOST SALES, LOST PROFITS, PRODUCT LOSS, PROPERTY DAMAGES, OR SERVICE EXPENSES) ARE EXPRESSLY EXCLUDED. THE EXPRESS WARRANTIES MADE IN THIS LIMITED WARRANTY MAY NOT BE ALTERED, ENLARGED, OR CHANGED BY ANY DISTRIBUTOR, DEALER, OR OTHER PERSON, WHATSOEVER.

LEGAL REMEDIES

The owner **must** notify Taylor in writing, by certified or registered letter to the following address, of any defect or complaint with the Part, stating the defect or complaint and a specific request for repair, replacement, or other correction of the Part under warranty, mailed at least thirty (30) days before pursuing any legal rights or remedies.

Taylor Company
750 N. Blackhawk Blvd.
Rockton, IL 61072, U.S.A.

