



VEC 16

PROGRAMMING SECTION

VEC 16 PROGRAMMING OPERATION

KEYWORDS:

VMC - VENDING MACHINE CONTROLLER **DMC**- DELIVERY MECHANISM CONTROLLER

The VEC 16 Controller uses a 4-button programming system:

- Programming Buttons:
- # 1 – Exit/ Home
 - # 2 – Increase/ Advance
 - # 3 – Decrease/ Backup
 - # 4 – Enter/ Save



DISPLAY KEYPAD

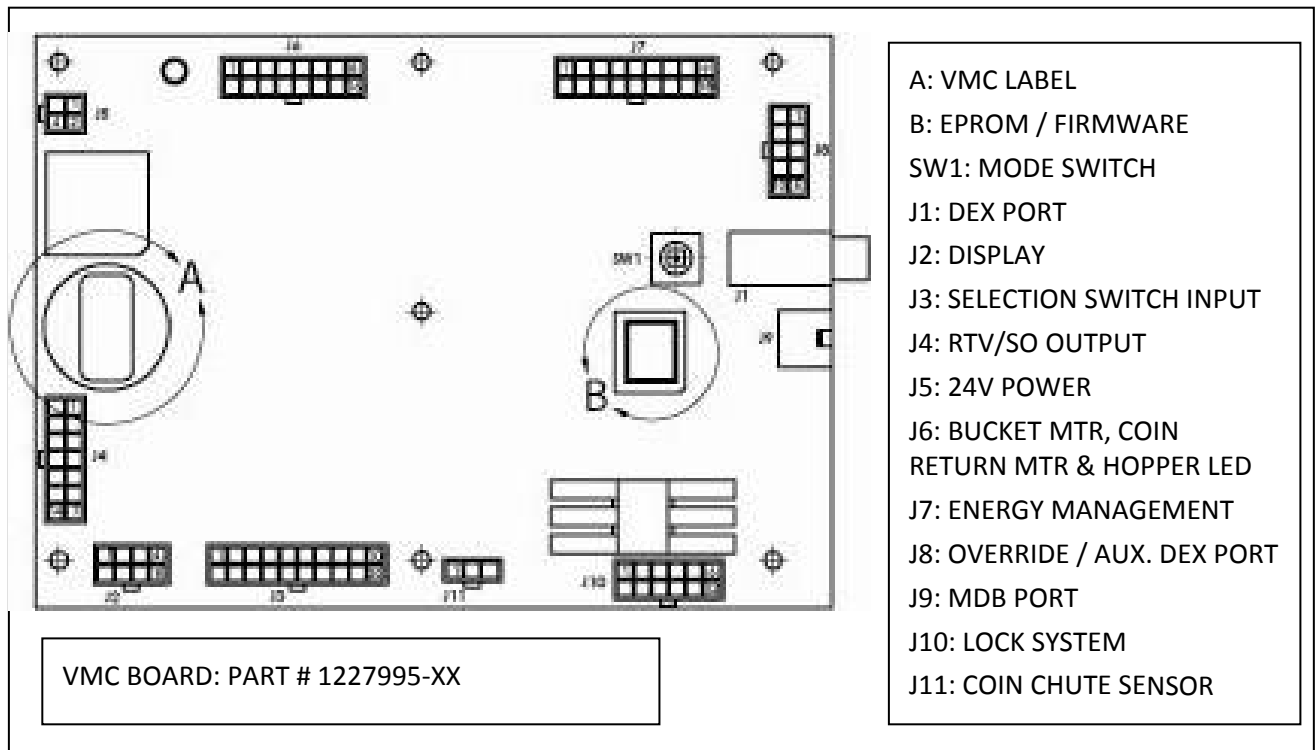

IMPORTANT INFORMATION:

General Process Description:

Ready to Vend Position: The catcher is at the bottom corner towards the hinge side of the machine – the fork on the catcher is pointing towards the trays.

Initialization Process: This process is activated during power up and Door Close scenario.

The catcher will rotate 90 Degrees clockwise, to confirm Z movement.

The catcher will move sideways about 3 inches away from the hinge side and will move back to the original position – to confirm X- location.

The catcher will move up about 4 inches and back to the base – to confirm the Y-location.

The catcher will perform a vend drop movement – to confirm that there is no product in the catcher.

The catcher will move up along the hinge side of the machine then towards the right and diagonally back to the original position – to confirm the shelf locations.

The catcher will rotate 90 degrees anti-clockwise to return to the Ready to Vend Position.

Recovery Process: This process is activated anytime there is a physical obstruction during the catcher or elevator movement. The vendor will initiate the initialization process on any motor jam. The vendor retries 5 times before terminating the recovery process. If the vendor fails to recover during its 5 retries, the machine is out of order.

To access Mode functions, open the door. Locate the Mode Button (SW1) on the Main Control Board and press until "Diagnostics" appears. Use selection button 2 or 3 to navigate through the modes.

The Modes are as follows:

Diagnostics
Coin Payout
Tube Fill
Test Mode
Cash Data
Sales Data
Discount Counter*
Free Counter*
Set Price
Shelf Location
Configuration
Door Closed Password
Set Language
Set Clock **
Lighting **
Refrigeration ***
Sales Block 1-8 **
Discount **
Override ****
Custom Message
Return

* For the Discount Counter and/ or Free Vend Counter to work, the option must be turned on and Set Clock Function must be activated and set. An override switch is required to activate the counters.

** These modes will only appear when the Timing Features in Configuration is turned On.

*** Limited options appear in this mode depending on whether the Timing Features in Configuration is On/Off.

**** A secondary 'kit' is required for this option.

Note: Items that are in quotes, for example: "X Motor", are what is displayed on the 20 character display:

Diagnostics:

Press Button 4 to enter Diagnostics Mode. If no errors have occurred, the display will read "Error None". If an error code displays, enter the code using Button 4. Press Button 2 to advance through the 'detailed summary' of the individual error codes. To clear the errors, press and hold Button 4. The display will read "Error None". To exit the Diagnostics Mode, press Button 1.

Coin Payout:

Coin Payout Mode allows the operator to test for proper operation of the coin changer.

1. Enter on Button 4.
2. Advance on Button 2 to choose denomination.
3. Enter on Button 4 to dispense denomination displayed.
4. Exit on Button 1.

Tube Fill:

The changer coin tubes can be filled via the external coin insert plate or the acceptor part of the changer. This mode enables the Control Board to keep an accurate count of the coins.

1. Enter on Button 4.
2. Insert coins through either the coin insert slot or acceptor part of the changer. The controller will display the value and quantity of coins in the changer tubes.

Test Mode:

Test Mode Vending:

Up to five products can be vended in this mode.

1. Press Button 4 – Display will read "Close Door to Vend".
2. Close outer door.
3. The elevator will perform its initialization routine.
4. Display will read "Please make a selection".
5. Product should dispense.

Test Mode Automated Check:

This mode is automated test mode and is designed to check all the operation in vending mode. This checks the Display, Keypad, Relays, Hopper Bucket operation, coin return operation and payment system.

1. Press Button 4.
 - a. This will automatically sequence through to check the display, keypad, relays, hopper operation, coin return operation and payment system.

Each check operation is allocated 15 seconds.

Test Mode Test Hopper Operation

1. Enter on Button 4 – “Testing in Progress” followed by ‘Hopper Bucket open/ Hopper Bucket close’ will display while performing these actions.
2. Confirm to make sure the display reads” Bucket Test Successful”
3. Exit on Button 1.

Test Mode Sensor Status:

1. Enter on Button 4 - Sensor Status display as follow:
ESCR |BCKT |FLP:
M●|S o |M●|B● |S●
The above status shows the vendor is in a “ready to vend” mode – otherwise check the respective sensor/ switch.
ESCR M : Escrow Motor Switch
ESCR S : Escrow Switch
BCKT M: Bucket Motor Switch
BCKT B: Bucket Base Switch
FLP S: Delivery Port Flap Switch
● : Switch is activated o : Switch is deactivated

Test Mode Display:

1. Enter on Button 4
2. 20””^” on each line should illuminate or all pixels should be illuminated.
3. Exit on Button 1

Test Mode Switches:

1. Enter on Button 4
2. Activation of individual selection buttons (1 – 10, * and #) should display
3. To Exit, press and hold Button 1 for 5 seconds or until Display returns to ‘Test Mode Switches’

Test Mode Relays:

This Mode allows you to test the following relays:

1. Compressor
 2. Fluorescent Light
 3. Heater
 4. Fan
1. Enter on Button 1 – Compressor ‘Off’
 2. Enter again on Button 4 – ‘Off’ flashes
 3. Advance on Button 2 – ‘On’ flashes
 4. Enter on Button 4 – Compressor should turn ‘on’ if relay is functional
 5. Exit on Button 1 – Compressor will default back to ‘Off’

Repeat steps 1 through 5 for desired relay. To exit ‘Test Mode’ and return to the Main Menu, press Button 1 three times.

Cash Data:

This Mode allows you to retrieve the total Historical Cash from product purchases.

1. Enter on Button 4 – the non-re-settable, Historical Cash Total will scroll
2. Advance on Button 2 to scroll through the shelves
3. Enter on Button 4 to show the columns in the shelves
4. Press Button 1 to exit.

Sales Data:

This Mode allows you to retrieve the total Historical Sales from product purchases.

1. Enter on Button 4 – the non-re-settable, Historical Sales Total will scroll
2. Advance on Button 2 to scroll through the selections
3. Enter on Button 4 to show the columns in the shelves
4. Press Button 1 to exit.

Discount Counter:

This Mode will only display when 'Discounts' are used. It allows access to the Sales and Cash Data for discounted vends.

1. Enter on Button 4 – 'Cash Data'
2. Enter again on Button 4 – Display will read 'Cash Data Total' and display the value of all discounts towards paid sales. This total is non-re-settable and begins when the 'Discount' feature is enabled.
3. Advance on Button 2 to scroll through the various selections
4. Press Button 1 to exit
5. Advance on Button 2 – 'Sales Data'
6. Enter on Button 4 – 'Sales Data Total' will display as well as the number of discounted sales. This total is non-re-settable and begins when the 'Discount' feature is enabled
7. Advance on Button 2 to scroll through the various selections
8. Press Button 1 to exit.

Free Counter:

This Mode will only display when 'Free Vends' were made. It allows the user access to the number of 'Free Sales and Cash Data' lost.

1. Enter on Button 4 – Cash Data total XX.XX, which is the value of the money lost based on the set price. This total is non-re-settable and begins when the 'Free Vend Override' is enabled.
2. Advance on Button 2 – 'Sales Data Total X', which is the total number of products dispensed. This total is non-re-settable and begins when the 'Free Vend Override' is enabled.
3. Press Button 1 to exit.

Clearing the Cash Data, Sales Data, Discount Counter or Free Counter:

*To reset the individual selection counter, scroll to the selection number, press and hold buttons # 1 and 4 for 3 seconds, **0000 will display**. You can also set 'MIS Auto Reset' to 'On' under 'Configuration'*

Shelf Position:

This Mode shows the shelf location for individual shelf in the machine. The distance of each shelf is based off the lowest shelf. The values are displayed in "inches"

Enter on Button 4

1. Advance on Button 2 – 'Shelf X Y inches' X : Shelf number , Y is the total distance from the bottom shelf
2. Press Button 1 to exit.

Factory Default 5 Shelf Setting:

Shelf 1: 42", Shelf 2: 32", Shelf 3: 21", Shelf 4: 10" ,Shelf 5: 0"

Please note: Shelf height will change if shelves are added or removed.

Set Price:

This Mode allows you the option to price each selection to the same vend price, or price each shelf, tray or column.

To set all selections to a 'single price':

1. Enter on Button 4 – All Selections .XX will display (current vend price)
2. Enter again on Button 4 – .XX (current vend price) will flash
3. Advance on Button 2 to increase the price
4. Press Button 3 to decrease the price
5. Press Button 4 to save change
6. Press Button 1 to exit.

To set price per shelf:

1. Enter on Button 4 – Set Price - Shelf 1
2. Enter on Button 4 again – Shelf 1 - All Columns displays
3. Enter on Button 4 – Shelf 1 – All columns XX flashes
4. Advance on Button 2/ decrease on Button 3 to desired price
5. Press Button 4 to save change – Shelf 1 – All columns XX
6. Press Button 1 – Set Price – Shelf 1
7. Advance on Button 2 – Set Price – Shelf 2
8. Set prices following steps outlined above for the balance of shelves
9. Exit on Button 1 twice to return to Set Price

To set price per column:

1. Enter on Button 4 – Shelf 1 – All Columns
2. Advance on Button 2 to begin pricing individual columns
3. Enter on Button 4 – Column 0 and current price flashes
4. Advance on Button 2/ decrease on Button 3 to desired price
5. Press Button 4 to save change

Set Price (Continued)

6. Continue as outlined above for all columns on Shelf 1
7. Press Button 1 to exit once all columns on Shelf 1 have been priced.
8. Advance on Button 2 – Shelf 2
9. Price columns as indicated above for Shelves 2 through 7
10. Exit on Button 1 twice to return to Set Price

Configuration:

To change individual options for Configuration Settings, enter the option on Button 4. Re-enter on Button 4, 'On or Off' will be flashing. Advance to 'On or Off' on Button 2 and save the change on Button 4. Program each Configuration Option in this manner.

Configuration Options are detailed below:

Multi-Price:

On – Selections may be programmed individually

Off – Single Price based on price of Selection 1

Timing Features:

On - Access to 'Clock Settings' and associated modes

Off – Access is denied

Door Summary:

On - Sales, Cash and Errors are displayed when outer door is opened

Off – Sales and Cash are not displayed, error summary will be

MIS Auto Reset:

On - Pressing the Door Switch will reset individual selection data back to 0

Off – Sales and Cash Data will not be reset by the Door Switch

Consumer Overpay:

On - Money will be accepted when the 'Correct Change Light' is on and there is insufficient coin in the coin tubes.

Off – Exact change only required to make a vend

Save Credit Timer:

On - Credit established will display for 5 minutes only

Off – Credit established will remain until a vend is made or the coin return is pressed.

Force Vend:

On - The consumer will not be able to deposit money, press the coin return and receive change without attempting to vend first.

Off – Vendor is set as a 'change' machine. Consumer can deposit money, press the coin return and receive change.

Multi-Vend:

On - The consumer may insert sufficient credit to make multiple purchases.

Remaining credit will display until consumer either makes another selection or presses the coin return.

Off – Consumer makes a single purchase and change is returned immediately.

Configuration (Continued)

Deny Escrow:

On - Validator will stack all bills received

Off – Validator will 'hold' the bill in 'escrow' until the vend is complete. If the consumer presses the coin return the 'bill' is returned to them.

S/O (Error) Indicator:

On - A small symbol - (◆) will appear in the lower right hand corner of the display when the vendor detects an error or a sold out column.

Off – The symbol will not appear.

Count by Selection/Price:

Count by Selection – Individual Sales and Cash Data are displayed.

Count by Price – Individual Sales and Cash Data is reported by vend price.

MIS Reset with DEX:

On - Non-Historical MIS Data will reset when a DEX read has been done.

Off – No MIS Data will be reset.

Double Talk: - This is a kit supplied by a third party source**

On - Module will vocalize messages.

Off – Module will not vocalize messages.

Display Scroll:

On - Messages 'Scroll' from left to right side of display.

Off – Messages do not scroll.

Display Temperature:

Off – Cabinet temperature will not display.

Ref – Internal Refrigeration Temperature will display as 'Refrigeration Temperature'.

Cbt – Internal Cabinet Temperature will display as 'Cabinet Temperature'. **

** Note: Requires Temperature Lockout Kit in order to display

Set # of Trays:

2/3 : Set the total number of trays in a machine : 2 : 6 Column , 3 : 9 column

DEX Version:

Trade/Coke/Pepsi - Options for machine type

Door Closed Password:

Allows the operator to set a password to access Sales Data when the door is closed. **This function does not work if a vend price is set at 0.00 **

1. Enter on Button 4 – current 'Password' will display with the 1st digit flashing indicating that it is ready to be edited
2. Press Buttons 2 and 3 to change the digits. NOTE: Valid digits are 1 through 6. The Password 0000 will disable this feature.
3. Press Button 4 to save digit and advance to the next
4. Press Button 4 after 4th digit is assigned – Door Closed Password will display

** Do not close door prior to programming all 4 digits of the password.

Set Language:

The current languages available for customer messages during sales mode are: English and Spanish.

1. Enter on Button 4 – current language will display
2. Enter on Button 4 again – current language flashes
3. Advance on Button 2 to desired language
4. Press Button 4 to save
5. Press Button 1 to exit.

Set Clock:

When the 'Timing Features' in Configuration Mode is turned 'On', this Clock can be set.

1. Enter on Button 4 at Set Clock – Enable Off will display (If no prior programming was done)
2. Enter on Button 4 – Off will flash
3. Press Button 2 to advance Off to On
4. Press Button 4 to save setting
5. Advance on Button 2 – 'Daylight Savings'
6. Enter on Button 4 – current setting will display
7. Press Button 4 – current setting flashes
8. Advance on Button 2 to desired setting
9. Press Button 4 to save setting
10. Press Button 1 to exit Daylight Savings
11. Advance on Button 2 - MM/DD/YYYY HH:MM will display
12. Enter on Button 4 – MM flashes (month)
13. Advance on Button 2 to correct month
14. Press Button 4 to 'save' – DD flashes (day)
15. Advance on Button 2 to correct day
16. Press Button 4 to 'save' – YYYY - with YY flashing (last 2 digits of year)
17. Advance on Button 2 to correct year
18. Press button 4 to 'save' – HH flashes (hour)
19. Advance on Button 2 to correct hour
20. Press Button 4 to 'save' – mm flashes (minutes)
21. Advance on Button 2 to correct minutes
22. Press Button 4 to save setting – MM/DD/YYYY HH:MM will display
23. Press Button 1 to exit - Set Clock

Lighting:

'Timing Features' in Configuration Mode must be turned 'On' to access this feature. You have the option to turn the lights or LED off once during a 24-hour period for energy conservation. The options available are Cabinet and LED.

Example:

Lighting Mode – Enable On/ Off
Lighting – Cabinet
Start Time 1 – Start Day 1 – Mon-Sun/Everyday
Start 1 hh:mm
Stop Time 1 – Stop Day 1 – Mon-Sun/Everyday
Stop 1 hh:mm
Lighting – LEDs
Start Time 2 – Start Day 2 – Mon-Sun/Everyday
Start 2 hh:mm
Stop Time 2 – Stop Day 2 – Mon-Sun/Everyday
Stop 2 hh:mm
* On – associated with a programmed start/stop
* Off – not associated with a programmed start/stop

1. Press Button 4 – 'Lighting – Mode Enable Off (if no prior program was set)
2. Press Button 4 – Off is flashing
3. Advance on Button 2 – On
4. Press Button 4 to save setting – Lighting – Mode Enable On
5. Press Button 4 to 'save'
6. Advance on Button 2 – Lighting Cabinet
7. Advance again on Button 2 – Lighting LEDs

To Set Lighting Cabinet or Lighting LEDs:

1. Press Button 4 to enter – Start Time 1(Lighting) or Start Time 2 (LEDs)
2. Press Button 4 again – Start Day 1 or 2 – mon-sun-everyday Off/On
3. Press Button 4 again – Off/On flashes
4. Press Button 2 to scroll between On/Off
5. Press Button 4 to save setting
6. Press Button 1 - Start Day 1 or 2
7. Advance on Button 2 - Start 1: 08:00 (if no prior programming was set – hh:mm)
8. Enter on Button 4 at 'Start 1 or 2 - the 08 flashes (hour)
9. Advance on Button 2 to desired setting

Lighting (Continued)

10. Press Button 4 to save – :00 begins flashing (minutes)
11. Advance on Button 2 to desired setting
12. Press Button 4 to save setting – Start 1 or 2 and hh:mm you programmed will display
13. Press Button 1 - Start Time 1or 2
14. Press Button 2 to advance to Stop Time 1or 2
15. Press Button 4 – Stop Day 1 or 2
16. Press Button 4 – Stop Day 1 or 2 – mon-sun-everyday Off/On
17. Repeat above steps for Stop Time 1or 2

Refrigeration:

If 'Timing Features' in Configuration Mode are 'Off', you will only have access to the following features:

Set point

Sensor Reading

Degree X – Celsius or Fahrenheit

Fan Default

Periodic Defrost – On/Off

When Timing Features is set on in Configuration, you can raise the cabinet temperature 18 °F/ 4°C twice during a 24 hour period for energy conservation.

Refrigeration:

1. Enter on Button 4 – 'Set Point'
2. Enter on Button 4 – current 'Set Point' will display – (Factory setting is 36°F/2°C)
3. Press Button 4 – current temperature will flash
4. Press Button 2 or 3 to scroll through the following settings:

Temperature setting	32	33	34	35	36	37	38	39	40
Cut-in Temperature (F)	34	35	36	37	38	39	40	41	42
Cut-out Temperature (F)	31	32	33	34	35	36	37	38	39
Nominal Temperature (F)	32	33	34	35	36	37	38	39	40
Nominal Temperature (C)	0	0.5	1	1.5	2	2.5	3	3.5	4

5. Press Button 4 to 'save' desired setting
6. Press Button 1 to exit – Set Point
7. Advance on Button 2 – Sensor Reading
8. Press Button 4 – Current reading in either F/C will display – must be set as Ref in Configuration first.
9. Press Button 1 – Sensor Reading
10. Advance on Button 2 – Degree F/C
11. Enter on Button 4 – current setting flashes
12. Press Button 2 to scroll between F/C
13. Press Button 4 to save desired setting

Refrigeration (Continued)

Fan Default:

Default Mode: Fan on when door closes and off when door opens.

Mode 1: Fan is time delayed with compressor cut in/cut out

1. At cut in, fan will come on after compressor turns on
2. At cut out, fan will continue to run 1 minute after compressor is off
3. Fan off with door switch activation

Periodic Defrost:

1. Press Button 4 – On/Off
2. Press Button 4 – On/Off flashes
3. Advance on Button 2 to desired setting
On – The vendor will defrost every 6 hours for 30 minutes. This feature is used in extremely high humidity environments.
Off – The vendor will not defrost every 6 hours.
4. Press Button 4 to 'save' setting
5. Press Button 1 to exit

When 'Timing Features' in Configuration are turned 'On', the following Modes are accessible:

Refrigeration – Enable Timer On/Off Start Time – Start Day 1/2 – Mon-Sun/All Start hh:mm Stop Time – Stop Day 1/2 – Mon-Sun/All Stop hh:mm
--

Enable Timer:

1. Press Button 4 – On/Off flashes
2. Advance on Button 2 to desired setting
3. Press Button 4 to 'save' setting
4. Press Button 2 – Start Time 1. Time Refrigeration turns off/begin conservation
5. Press Button 4 – Start Day 1
6. Press Button 4 – current setting flashes
7. Press Button 2/ 3 to scroll through days of the week or 'All'
8. Press Button 4 – On/Off flashes
9. Advance on Button 2 to desired setting
10. Press Button 4 to 'save' setting
11. Press Button 1 to exit – Start Day 1
12. Press Button 2 to advance to Start 1 hh:mm
13. Press Button 4 at Start 1 hh:mm – hh flashes

Refrigeration (Continued)

14. Press Button 2 to set the hh
15. Press Button 4 to 'save' setting – mm flashes
16. Press Button 2 to set: mm
17. Press Button 4 to 'save' setting
18. Press Button 1 to exit – Start Day 1
19. Advance on Button 2 – Stop Day 1
20. Follow the steps outlined above to complete Stop Time 1, Start Time 2, Stop Time 2
21. Press Button 2 to advance

TempLO (Temperature Lock Out):

1. Enable timing feature in configuration
2. Advance on button 2 to TempLO shlf 1
3. Press Button 4 – Disable will flash
4. Advance on Button 2 – Enable
5. Press Button 4 to 'save' setting
6. Continue in above manner for all shelves associated with Temperature Lockout

Note: The Temperature Lockout Feature (TempLO) requires an additional temperature sensor connected at the top left on the inside of the cabinet. When the cabinet temperature is above 41°F/ 3.5 °C for more than 15 minutes, the vendor will shut down any shelves associated with the Temperature Lockout Feature.

Sales Block: (8 Blocks are available in this Mode)

Sales Block allows the operator to turn Selections On/Off at 8 intervals during a 24-hour period. Times must not overlap. You must enter the following information:

- Selections – the selection buttons that will be disabled during the blocked time
- Start Time – the time selections will be 'Off Line'
- Start Days – the days selections will be 'Off Line'
- Stop Time – the time selections will turn back 'On'
- Stop Days – the days selections will turn back 'On'

Sales Block 1:

1. Press Button 4 – Enable On/Off, Light
 - Enable Off – Block Function is disabled
 - Enable On – Block Function is enabled
 - Enable Light – Block Function is enabled and lights are off when blocking occurs
2. Press Button 4 – On/Off Light flashes
3. Press Button 2 to advance to desired setting
4. Press Button 4 to 'save' setting – your choice will display
5. Press Button 2 to advance to – Selections

Sales Block (Continued)

Choose Selections:

1. Press Button 4 at Selections – All Selections On/Off will display
2. Press Button 4 – On/Off flashes
3. Advance on Button 2 to desired setting
4. Press Button 4 to 'save' setting
5. Press Button 1 to exit

Set all Selections:

1. Press Button 4 – All Selections On/Off
2. Press Button 4 – On/Off flashes
3. Press Button 2 to advance to desired setting
4. Press Button 4 to 'save' setting
5. Press Button 1 to exit – Selections

Selections per Shelf:

1. Press Button 4 – All Selections On/Off
2. Press Button 2 to advance to desired shelf
3. Press Button 4 – All Columns
4. Press Button 4 again – On/Off flashes
5. Press Button 2 to advance to On/Off
6. Press Button 4 to 'save' setting
7. Press Button 1 twice to exit – Selections

Set Columns:

1. Press Button 4 – All Selections On/Off
2. Press Button 2 to advance to desired shelf
3. Press Button 4 – All Columns
4. Press Button 2 to advance to desired Column
5. Press Button 4 – On/Off flashes
6. Press Button 2 to advance to desired setting
7. Press Button 4 to 'save' setting
8. Press Button 1 twice to exit

Sales Block (Continued)

Start Time: (Beginning of Blocking Period)

1. Press Button 2 – Start Time
2. Press Button 4 – Start Day
3. Press Button 4 – Every Day
4. Press Button 2 or 3 to select days or Every Day
5. Press Button 4 to change the status of the days – On/Off flashes
If the status is 'On', product delivery is blocked
If the status is 'Off', product delivery is normal
6. Press Button 2 to change status
7. Press Button 4 to 'save' setting
8. Press Button 1 – Start Day
9. Press Button 2 – Start hh:mm
10. Press Button 4 – hh (hour setting) flashes
11. Press Button 2 to advance to desired Start Hour. (Military Time)
12. Press Button 4 to 'save' setting -: mm flashes
13. Press Button 2 to advance to desired minutes
14. Press Button 4 to 'save' setting
15. Press Button 1 to exit and return to Start Time

Stop Time: (End of Blocking Period)

1. Advance on Button 2 – Stop Time
2. Press Button 4 – Stop Day
3. Press Button 4
4. Press Button 2 or 3 to select days or Every Day
5. Press Button 4 to change the status of the days – On/Off flashes
If the status is 'On', product delivery is blocked
If the status is 'Off', product delivery is normal
6. Press Button 2 to change status
7. Press Button 4 to 'save' setting
8. Press Button 2 – Stop hh:mm
9. Press Button 4 – hh (hour setting) flashes
10. Press Button 2 to advance to desired Start Hour. (Military Time)
11. Press Button 4 to 'save' setting -: mm flashes
12. Press Button 2 to advance to desired minutes
13. Press Button 4 to 'save' setting
14. Press Button 1 to exit and return to Stop Time
15. Pressing Button 1 again will return the operator to Sales Block 1-8 mode

Discount:

This feature permits the operator to program the vendor to discount product once during a 24-hour period. To program a Discount, you must enter the following information:

Discounted Selection(s) – Selection(s) offered at a discounted price

Start Time – Time the Discount begins

Start Day(s) – Days the Discount is offered

Stop Time – Time(s) Discount ends

Stop Day – Day(s) the Discount ends

Amount – Amount subtracted/discounted from original vend price

Choose Selections:

1. Press Button 4 – Enable On/Off
Enable Off – Discount function is disabled
Enable On – Discount function is enabled
2. Press Button 4 – Off flashes
3. Press Button 2 to select desired setting
4. Press Button 4 to 'save' setting – Enable 'On' will display
5. Press Button 2 – Discounted Selection

Set Discount for 'All' Selections:

1. Press Button 4 – Discount all selections 'Off'
2. Press Button 4 – 'Off' flashes
3. Press Button 2 to Advance to 'On'
4. Press Button 4 to 'save' setting
5. Press Button 1 to exit

Set Discounted Selections per Shelf:

1. Press Button 4 – Discount All Selections 'Off'
2. Advance on Button 2 to desired shelf number
3. Press Button 4 to enter – Shelf X - All Columns 'Off'
4. Press Button 4 – On/Off flashes
5. Advance on Button 2 to desired setting
6. Press Button 4 to 'save' setting
7. Press Button 1 to exit

Start Time:

1. Advance on Button 2 – Discount Start Time
2. Press Button 4 – Discount Start Day

Discount (Continued)

3. Press Button 4 – Mon-Sun/Everyday
4. Press Button 4 again – Everyday flashes
5. Advance on Button 2 to desired day
6. Press Button 4 – On/Off flashes
7. Advance on Button 2 to change current status
8. Press Button 4 to 'save' setting
9. Set balance of Selections in manner described above
10. Exit on Button 1 – Discount Start Day
11. Advance on Button 2 – Start hh:mm (hour/ minutes)
12. Press Button 4 – hh flashes
13. Advance on Button 2 to desired setting
14. Press Button 4 to 'save' setting :mm flashes
15. Advance on Button 2 to desired setting
16. Press Button 4 to 'save' setting
17. Press Button 1 to exit – Start Time

Stop Time:

1. Advance on Button 2 – Stop Time
2. Press Button 4 – Stop Day
3. Press Button 4 – mon-sun/everyday
4. Press Button 4 again – everyday flashes
5. Advance on Button 2 to desired day
6. Press Button 4 – On/Off flashes
7. Advance on Button 2 to change current status
8. Press Button 4 to 'save' setting
9. Set balance of Selections in manner described above
10. Exit on Button 1 – Stop Day
11. Advance on Button 2 – Stop hh:mm (hour/ minutes)
12. Press Button 4 – hh flashes
13. Advance on Button 2 to desired setting
14. Press Button 4 to 'save' setting :mm flashes
15. Advance on Button 2 to desired setting
16. Press Button 4 to 'save' setting
17. Press Button 1 to exit – Stop Time

Discount (Continued)

Set Discount Amount:

The Discount is the amount being subtracted from the regular vend price.

1. Press Button 4 - .00 flashing
2. Advance on Button 2 to desired discount amount
3. Press Button 4 to 'save' setting
4. Press Button 1 to exit – Discount Amount

Override: (Optional Kit)

The Key Switch Override Kit allows the operator to 'bypass without removing' Timing Features the operator has programmed in the controller.

On – Key Switch will override these Timing features.

Off – Key Switch will not override these Timing features.

The following Timing features can be programmed to the key switch.

Free Vend – On/Off

Sales Blocking – On/Off

Discount – On/Off

Light Timing – On/Off

Refrigeration – On/Off

Free Vend:

1. Enter on Button 4 – On/Off flashes
2. Advance on Button 2 to desired setting
3. Press Button 4 to 'save' setting
4. Press Button 1 to exit – Free Vend

Program Sales Blocking, Discount, Light Timing and Refrigeration in the manner described above. Press Button 1 to exit.

Custom Message:

The custom message feature allows the operator to program a 2 line X 20 character message.

Note:

1. Press Button 1 to make a space between words.
 2. The message cannot be saved until all the characters on the top line have been entered.
-
1. Press Button 4 at Custom Message – Enable On/Off
 2. Press Button 2 – On/Off flashes
 3. Advance on Button 2 to On
 4. Press Button 4 to 'save' setting
 3. 5 Advance on Button 2 – current messages displays
 5. Press Button 4 – 1st character flashes
 6. Press Button 2 to advance to desired character
 7. Press Button 4 to 'save' character – immediately advances to next character
 8. Continue setting message using steps outlined above
 9. Press and hold Button 1 for 3 seconds to save the message and exit mode

Return:

Exits the programming mode and returns the vendor to stand-by.

WIRING DIAGRAM

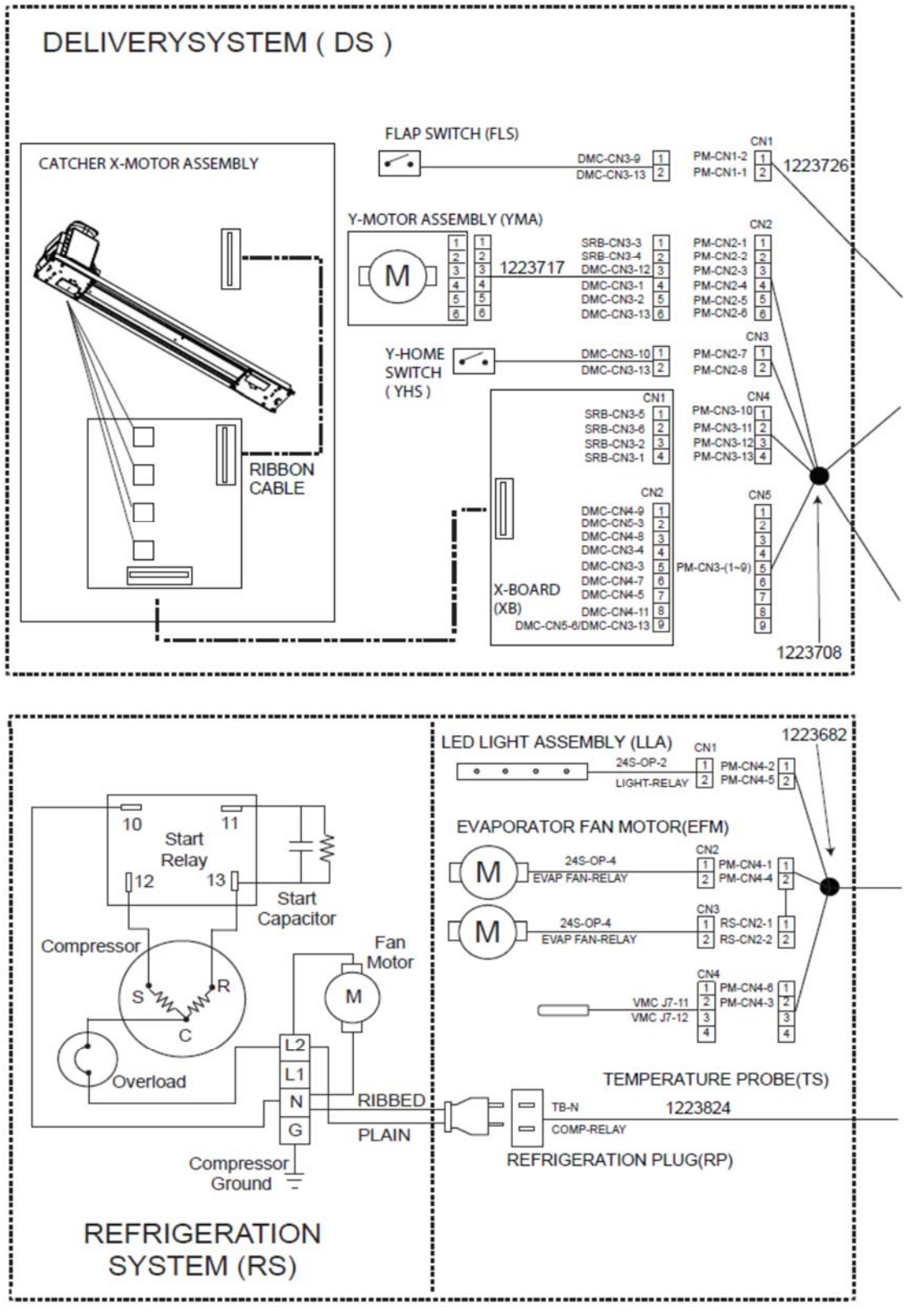

WIRING DIAGRAM (CONTD)

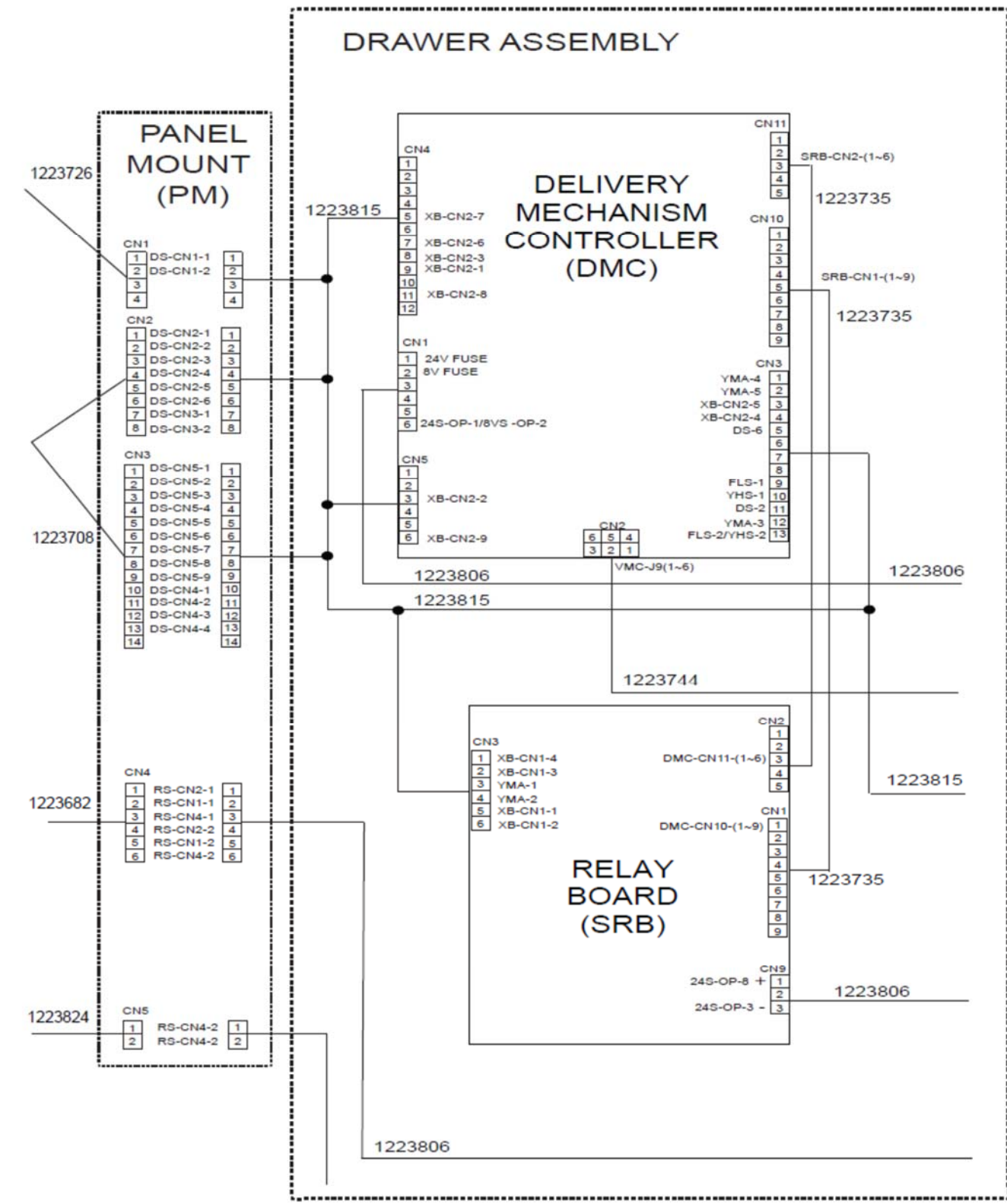

WIRING DIAGRAM (CONTD)

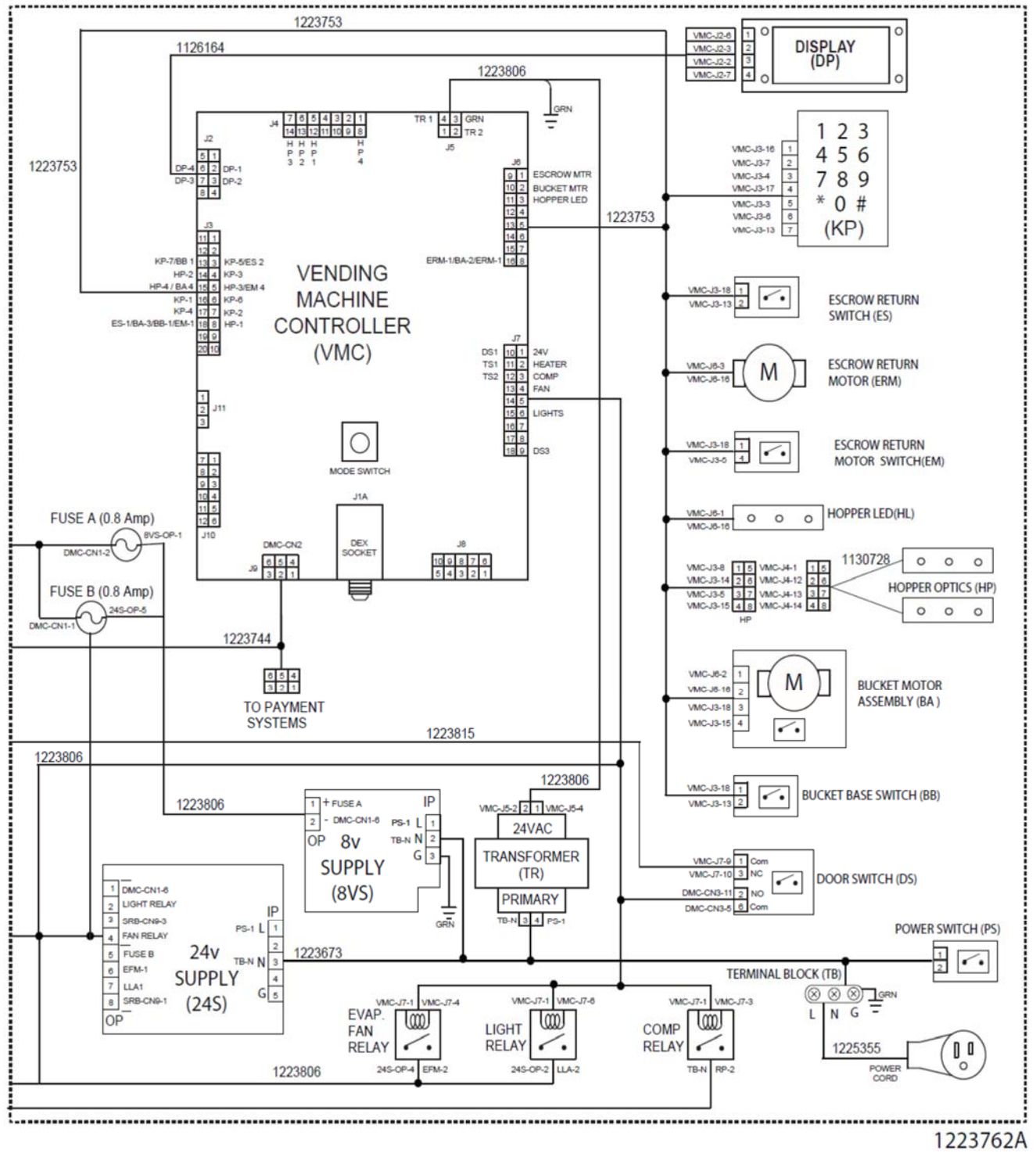

1223762A



SAFETY INSTALLATION, SETUP & INSTALLATION SECTION

**Manufactured by
SandenVendo America INC.
10710 Sanden Dr.
Dallas, TX 75238-1335
(800) 344-7216
Fax: (800)541-5684
Web: www.vendoco.com**

A COMMITMENT TO SAFETY

SandenVendo America, Inc. is committed to safety in every aspect of our product design. SandenVendo America, Inc. is committed to alerting every user to the possible dangers involved in improper handling or maintenance of our equipment. The servicing of any electrical or mechanical device involves **potential hazards**, both to those servicing the equipment and to users of the equipment. These hazards can arise because of improper maintenance techniques. The purpose of this manual is to alert everyone servicing SandenVendo America, Inc. equipment of potentially hazardous areas, and to provide **basic safety guidelines** for proper maintenance.

This manual contains various **warnings** that should be carefully read to minimize the risk of personal injury to service personnel. This manual also contains service information to insure that proper methods are followed to avoid damaging the vendor or making it unsafe. It is also important to understand these **warnings** are not exhaustive. SandenVendo America, Inc. could not possibly know, evaluate, or advise of all of the conceivable ways in which service might be done or predict all of the possible hazardous results. The safety precautions outlined in this manual provide the basis for an effective safety program. Use these precautions, along with the service manual, when installing or servicing the vendor.

We strongly recommend a similar commitment to safety by every servicing organization. Only **properly-trained personnel should have access to the interior of the machine**. This will minimize the potential hazards that are inherent in electrical and mechanical devices. SandenVendo America, Inc. has no control over the machine once it leaves its premises. It is the owner or lessor's responsibility to maintain the vendor in a safe condition. See Section I of this manual for proper installation procedures and refer to the appropriate service manual for recommended maintenance procedures. If you have any questions, please contact the Technical Services Department of the SandenVendo America, Inc. office nearest you.

SAFETY RULES

- **Place and store unit inside. Outdoor use or storage voids warranty and can result in an unsafe condition**
- Read the Safety Manual before installation or service.
- Test for proper grounding before installing to reduce the risk of electrical shock and fire.
- Disconnect power cord from wall outlet before servicing.
- Use only fully-trained service technicians for Power- On servicing.
- Remove any product prior to moving a vendor.
- Use adequate equipment when moving a vendor.
- Always wear eye protection, and protect your hands, face, and body when working near the refrigeration system.
- Use only authorized replacement parts.
- Be aware of inherent dangers in rocking or tipping a vending machine.

SECTION I: VENDOR SETUP & INSTALLATION

- A. Vendors are large, bulky machines of significant size and weight. Improper handling can result in injury. When moving a vendor, carefully plan the route to be taken and the people and equipment required to accomplish the task safely.
- B. Remove all tape, shipping sealant, and Styrofoam from the vendor. Loosen any shipping devices used to secure interior parts during shipping. Remove the wooden shipping boards attached to the vendor base by the vendor leveling screws. Make certain the leveling screws are in place and functional.
- C. Position the vendor on a flat smooth surface 3 to 4 inches (7.6 cm to 10.2 cm) from a well-constructed wall.

IMPORTANT: *The vendor requires 3 inches (7.6 cm) of air space from the wall to ensure proper air circulation to cool the refrigeration unit.*

- D. Adjust the leveling screws to compensate for any irregularities on the floor surface. Ideally, no adjustment will be necessary and the leveling legs will be flush with the bottom of the vendor. A spirit level is a useful aid to level the vendor. When the outer door is open, it will remain stationary if the vendor is properly leveled. Vendors must be level to ensure proper operation and to maintain stability characteristics. Do not add legs to the vendor. **The leveling legs shall not raise the vendor more than 1 1/8 inch (2.5 cm) above the ground.**
- E. Check the manufacturer's nameplate on the left or right side of the vendor's outer door to verify the main power supply requirements of the vendor. Be sure the main power supply matches the requirements of the vendor. To ensure safe operation, plug the vendor only into a properly grounded outlet.
DO NOT USE EXTENSION CORDS.
DO NOT USE PLUG ADAPTORS.
- F. Recommended voltage specs = 115V ± 10%
- G. Dedicated 15A service required for 1 machine.
- H. Power outlet must be properly polarized and grounded.

NOTE: Any power supply variance more than ± 10% may cause the vendor to malfunction.

SECTION I: VENDOR SETUP & INSTALLATION (CONTINUED)



WARNING



**THIS APPLIANCE MUST BE EARTHED.
IMPORTANT!**

**IF THE ABOVE CONDITIONS ARE NOT MET FOR THE GIVEN OUTLET
TYPE, CONTACT A LICENSED ELECTRICIAN AND HAVE THE NECESSARY
CORRECTIONS MADE.**

NOTE: Refer to the appropriate parts and service manual available online @ www.vendoco.com for detailed instructions, operating principles, and recommended maintenance intervals and procedures.

SECTION I: VENDOR SETUP & INSTALLATION (CONTINUED)

Set up Procedure

Note: Do not plug in the vendor until
 Step 5

1	Unwrap the machine
2	Remove all the tie wraps and packaging material
3	Level machine as needed - See leveling instructions
4	Confirm the trays fully seated in the base
5	Power on the machine
Display will read-Memory operation, Data Transfer in Process This is the process of communication between the Vending Machine Controller(VMC) and Delivery Mechanism Controller (DMC)	
6	Close the door –The machine will start initialization. The catcher will perform a product drop movement The product catcher will move up and scan for each shelf location - then move towards the right side of the machine and then will move to the left side at position (bottom hinge side)
CAUTION: Do not open the door while the elevator is in motion as this would cause the elevator to free fall	
8	The display should read "Ice cold Beverages!! Please Make a Selection"
9	Open the door – load the machine
10*	Set the machine to free vend
11	Test vend to check the vendor is working properly
12*	Set Price for all selection

*Refer to Programming Manual

Products Specification – General Guidelines

Products* (PET, glass bottles, cans):
Height range: 3 in – 9.25 in (76mm - 235mm)
Diameter range: 1.7 in – 3 in (43mm - 76mm)
Weight range: 6.5oz – 23oz (185g - 653g)

Loading Instructions

Please note: To ensure freshness of the product - do not load from the front of the vendor. GGFV has FIFO product loading capability

1	Lift and pull the front of the tray assembly.
2	Push and lock the product pushers to the back of the tray.
3	Load the products into the tray.
4	Once the products are loaded - push the tray back in its position – The product pushers will automatically snap back behind the last product For proper vending – Please make sure the products are not leaning forward or sitting up on tray front. Do not activate the product pusher when the columns are empty (damage will occur)
5	Check the tray is fully seated on the front support bar.
6	To ensure the product pusher is engaged - Gently push the front product inward to check for resistance
7	Check to confirm all products are resting on tray bottom (behind the tray product retaining hooks)

Loading selection # 50, 51 , 52 :

Push and hold the product delivery port flap open until the product catcher moves towards the right side of the vendor to clear the loading zone for 50, 51 and 52.
Load the shelves as indicated by Step 1 – 7
Close the door.
The catcher will move to home position

*Note: Due to variability of package design, material & weight, performance may vary.
 Testing of odd shaped, size products should be done to determine acceptability. *Continued.*

Carton packs* (Aseptic package):
Height range: 3.3 in – 5.3 in (85mm - 134mm)
Width range: 2 in – 2.6 in (52mm - 67mm)
Depth range: 1.6 in – 1.8 in (40mm - 47mm)
Weight range: 7.5oz – 14oz (213g - 400g)

*For tall/unstable bottles, we recommend using side spacers to keep bottles from leaning sideways (Please see below)

8.5" – 9.25"

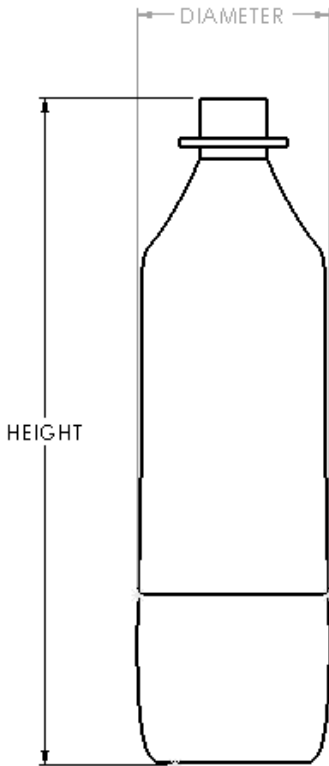

SPACERS SPECIFICATION		
BOTTLE DIAMETER	BOTTLE HEIGHT	SIDE SPACER
< 2.4"	8.5" - 9.6"	1252577
2.4"<D<2.8"	8.5" - 9.6"	1254502

SECTION II: MAINTENANCE REQUIREMENT

- 1- Remove Trays and clean bottom slider (Every Six months or when spills occur)
 (Note: dirty slider can prevent bottles from advancing)
- 2- Apply grease into the side partitions and pushers (Every Six months or as needed).
- 3- Clean the X-rail from any debris or syrup along the ribbon cable guide (When spills occur)
- 4- Vacuum the Condenser fins and clean the base from any dust (Every 3 months or as needed)
- 5- Check all harnesses in the drawer assembly are intact (Every 6 months)
- 6- Check Bucket motor switch/bucket base for any syrup or debris (Every 3 months or as needed)

SECTION III: ELECTRICAL HAZARDS

GENERAL

SandenVendo America, Inc. vending machines are provided with the appropriate power supply setting for your area.

The power sources mentioned are standard for both household and commercial lighting and appliances. However, careless or improper handling of electrical circuits can result in injury or death. Anyone installing, repairing, loading, opening, or otherwise servicing a vending machine should be alerted to this point. Apply all of the normal precautions observed in handling electrical circuits, such as:

- Unplug the vendor before servicing or clearing product jams.
- Replace electrical cords if there is any evidence of fraying or other damage.
- Keep all protective covers and ground wires in place.
- Plug equipment into outlets that are properly grounded and polarized, and protected with fuses or circuit breakers.
- All electrical connections must be dry and free of moisture before applying power.
- Replace Fuses with same type.
- Refrigeration servicing to be performed by qualified personnel only.

A. Grounding Systems

SandenVendo America, Inc. vending machines are provided with the appropriate service cord for the power supply in your area. The service cord will connect to the matching electrical outlet. Always ensure that the outlet to be used is properly grounded before plugging in the vendor.



The electrical grounding system also includes the bonding of all metal components within the vendor. This involves a system of bonding wires identified by green or green and yellow marking. The system uses serrated head screws, lock washers, and star washers to ensure the electrical connection between parts. Maintenance of vending equipment may involve disassembly. Include the above items when reassembling, even if the vending machine may appear to function normally without them. Omitting any of these items can compromise a link in the grounding system.

SECTION III: ELECTRICAL HAZARDS (CONTINUED)

B. Servicing with “Power Off”

For maximum safety, unplug the service cord from the wall outlet before opening the vendor door. This will remove power from the equipment and avoid electrical and mechanical hazards. Service personnel should remain aware of possible hazards from hot components even though electrical power is off.

C. Servicing with “Power On”

Some service situations may require access with the power on. Power on servicing should be performed **only by fully-qualified service technicians**. Particular caution is required in servicing assemblies that combine electrical power and mechanical movement. Sudden movement (to escape mechanical action) can result in contact with live circuits and vice versa. It is therefore doubly important to maintain maximum clearances from both moving parts and live circuits when servicing.

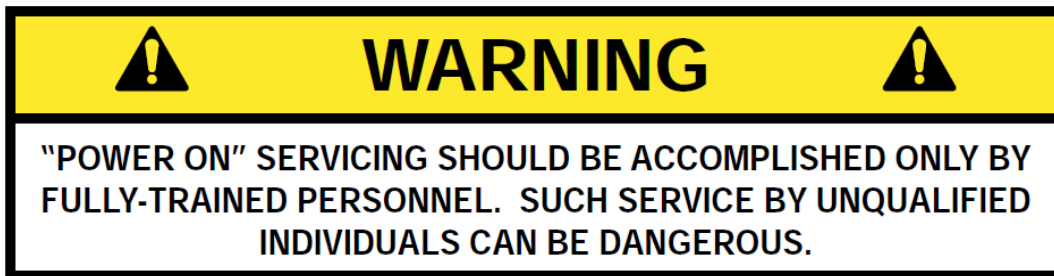

Power to lighting and refrigeration system is shut off automatically by the electronic controller when the outer door is opened. However, it is strongly recommended that servicing the lighting system or the refrigeration system only be performed after unplugging the vendor power cord, or by turning the power switch off (See Figure 1).

NOTE: For power-on servicing of the vendor's lighting system, turn lighting power on by accessing the Lights test function of the electronic controller, or by pulling the door switch forward to the override position.

Caution:

After the door switch is pulled forward or door closed, the elevator will move automatically as part of the homing routine.

Always make sure the path of the elevator and the rail is clear before closing the door or pulling the door switch forward.

Caution: Do not open the door while the elevator is moving.

For power-on servicing of the vendor's refrigeration system, turn refrigeration power on by accessing the Compressor test function of the electronic controller, or by pulling the door switch forward to the override position. Note that there will be a delay of 3 minutes before the compressor is energized.

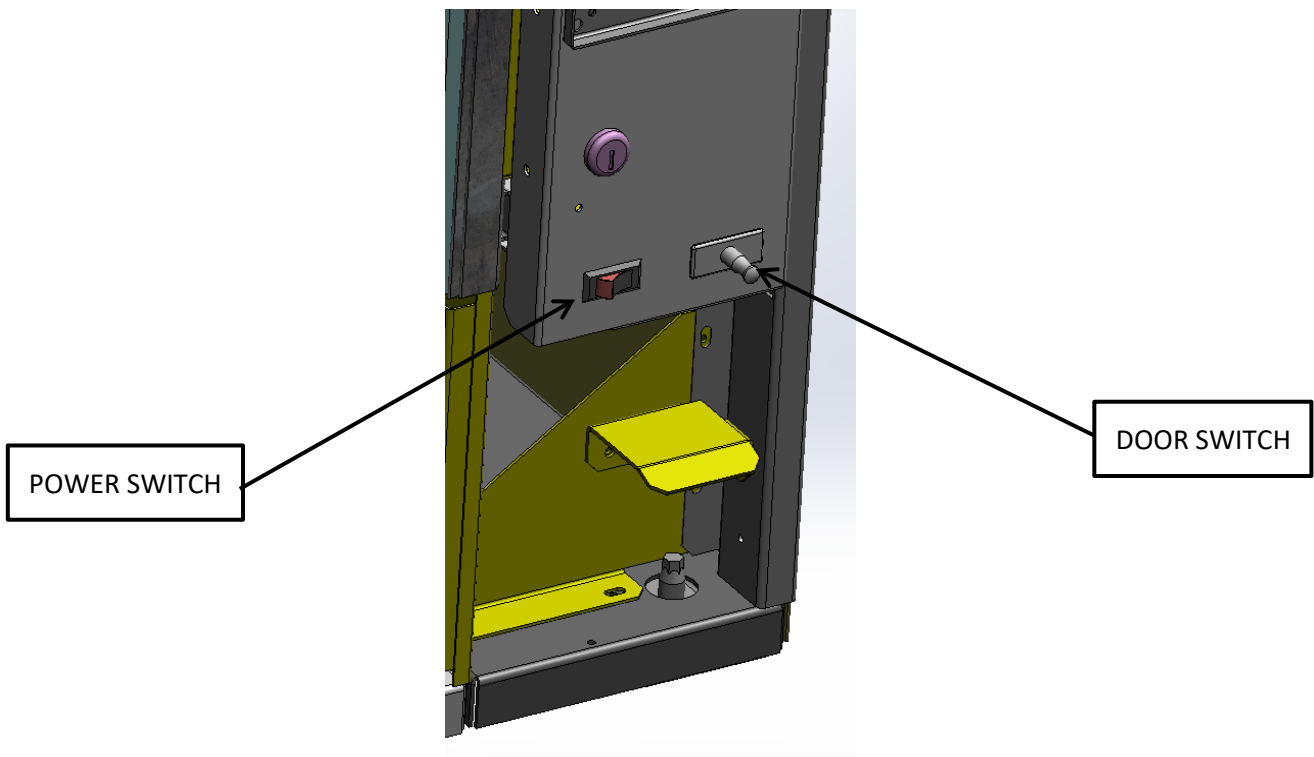

FIGURE 1

SECTION IV: MECHANICAL HAZARDS

A. Servicing of Moving Parts and Assemblies

When servicing assemblies involving moving parts, **use extreme caution!!** Keep fingers, hands, loose clothing, hair, tools, or any foreign material clear of entrapment.

As noted before under the electrical hazards section, Power On servicing should **only** be performed by qualified personnel. Refer to and heed the warnings noted in the electrical hazards section. These warnings refer to the potential hazards associated with electrical power and moving parts. Always maintain maximum clearances from electrical and moving parts.

Always install protective covers and guards when reassembling equipment.

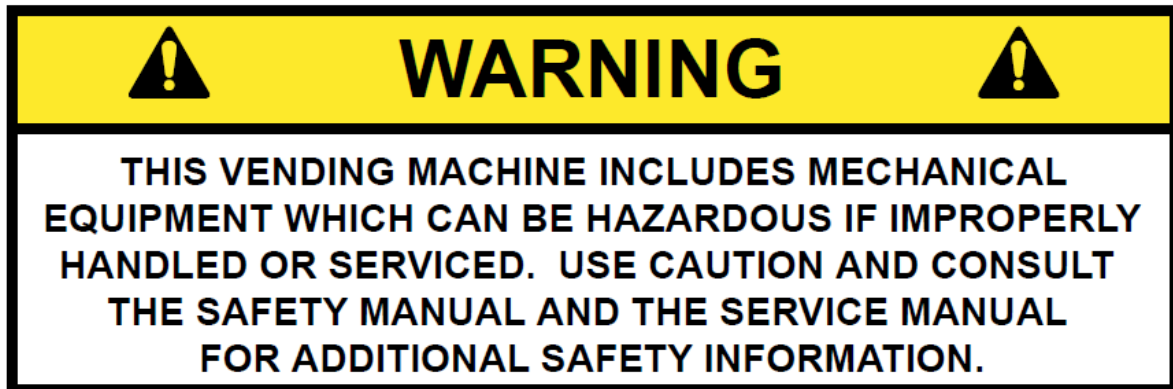

SECTION V: REFRIGERATION HAZARDS

GENERAL

Refrigeration systems involve both electrical power and mechanical action. These systems may present any of the potential dangers shown in the sections on electrical and mechanical hazards contained in this manual. See Sections II and III for further information.

A. Compressed Refrigerant

Refrigeration systems involve the compression and evaporation of gases. The pressures contained represent a potential hazard if suddenly released in confined areas. Caution is required when performing maintenance tests or repairs. All testing of sealed refrigeration systems must be done by trained personnel who are familiar with the systems and pressures involved.

B. Physical Protection

The accidental release of refrigerant gases can result in physical injuries. Always wear protective glasses and protect your hands, face, and body when working near the refrigeration system.



R290 REFRIGERANT (PROPANE)

For units that use R290 refrigerant, please use additional caution as described below.

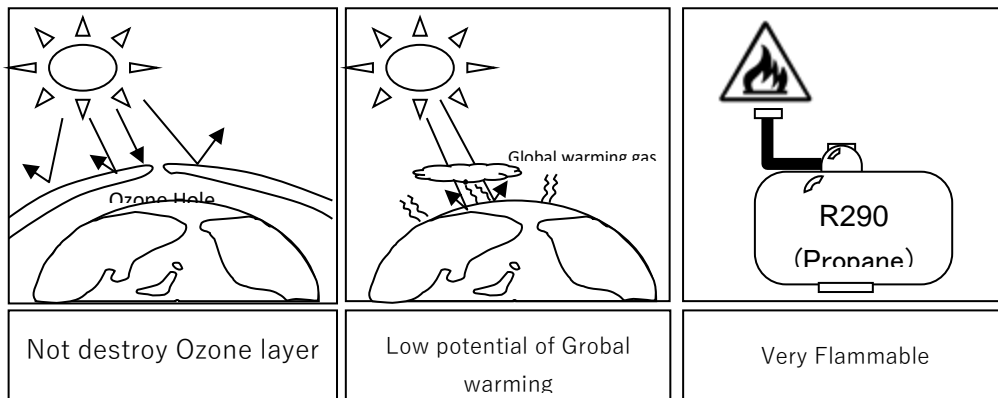

Refrigerant	R290 (Propane)
Ozone Destructive Potential	0
Global Warming Potential	3
Permission Concentration	1,000 ppm
Operating pressure	180 psig (1.2 MPa)

DANGER:

Risk of fire or explosion. Flammable refrigerant used. Use extreme caution when handling, moving unit as to not increase risk of damage to refrigerant tubing or increasing the risk of a leak.

Caution:

The refrigeration unit contains R290 (Propane). Only a service technician that has been trained with the operation of R290 (Propane) should service the refrigeration system, so as to minimize the risk of possible ignition due to incorrect parts or improper service. Components parts shall be replaced with like components.

Notice:

This vending machine uses less than 114 grams (3xLFL) of R290 (A3 Propane) refrigerant. For R290 LFL=38 g/m³. Therefore, has no special placement restrictions (as compared to A1 refrigerants e.g. R134a) and can be used in lobbies or locations of egress, such as a hallways or public corridors.

SECTION VI: TEMPERATURE HAZARDS

GENERAL



Maintenance personnel should be alerted to the potential hazards from hot metal surfaces. High temperatures may be present throughout the refrigeration system even though electrical power has been removed.

SECTION VII: SUBSTITUTIONS AND MODIFICATIONS

GENERAL

Unauthorized changes or the substitution of unauthorized parts can compromise the equipment designs. This can result in unsafe conditions for either the service personnel or the equipment users. Always refer to the appropriate parts and service manual for replacement parts and maintenance instructions. If questions arise, contact the Technical Services Department of the SandenVendo America, Inc. office in your area.

When servicing the vending machine, always reassemble all components to their original location and position. Maintain the correct routing for tubing, electrical wiring, etc. Replace all clamps, brackets, and guides to their original locations. Replace all tubing, sleeving, insulating material, and protective covers to their original condition.

 WARNING 
VENDO EQUIPMENT HAS BEEN PROVIDED WITH APPROPRIATE PROTECTIVE DEVICES TO PROTECT AGAINST THE POSSIBILITY OF OVERHEATING AND FIRE AS A RESULT OF EQUIPMENT OR COMPONENT FAILURES. SUBSTITUTION, MODIFICATION, OR BYPASSING OF SUCH PROTECTIVE DEVICES CAN CREATE DANGEROUS CONDITIONS. PROTECTIVE CIRCUITS SHOULD NEVER BE BYPASSED, AND FAILED PROTECTIVE DEVICES MUST BE REPLACED ONLY WITH FACTORY-AUTHORIZED PARTS.

A. Service Cord Replacement

SandenVendo America, Inc. vending machines are furnished with unique power supply cords. If replacement becomes necessary, consult the appropriate parts and service manual and order the correct replacement cord for the model of vending machine in question. Do not use substitute replacement cords. Only authorized service personnel with appropriate training should replace the vending machine service cord. If a question should arise concerning which service cord to order, contact the Technical Services Department of the SandenVendo America, Inc. office in your area.

SECTION VIII: CONSUMER SAFETY WARNING



GENERAL

There have been incidents, including fatalities, when vending machines have been vandalized by being pulled over in an attempt to obtain free product or money.

To warn of the danger involved in tipping, shaking, or rocking the vending machine, a decal has been designed to be affixed to vending machines. (One such decal is applied on the vending machine.) SandenVendo America, Inc. will supply sufficient decals to be placed on all machines, on request. If you have any questions, contact the Technical Services Department of the SandenVendo America, Inc. office in your area.

THE FOLLOWING DECAL SHOULD BE PLACED IN A POSITION ON THE VENDOR CONTROL PANEL AT EYE LEVEL



ENGLISH

FRENCH

SPANISH



DRAWER COMPONENTS

DRAWER ASSEMBLY OUTSIDE

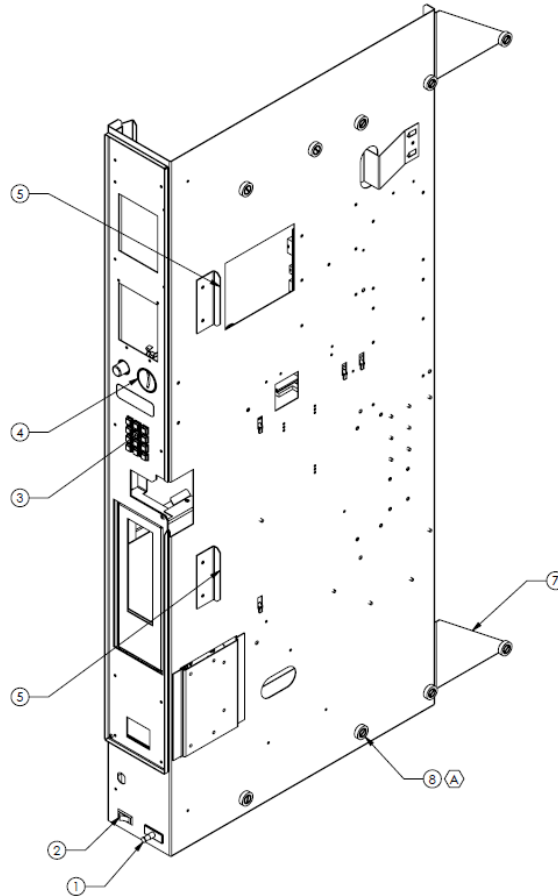

ITEM NO	DESCRIPTION	QTY	PART NO
	SIDE DRAWER ASSEMBLY	1	1235478
1	CHEAT-INTERLOCK DOOR SWITCH	1	1258524
2	SWITCH,ROCKER,125VAC,20A	1	1187843
3	KEYPAD	1	1217184
~	BRACKET, KEYPAD SUPPORT	1	1217193
4	COIN INSERT ASSEMBLY	1	SEE PAGE A-5
5	DRAWER STOP BRACKET	2	1220484
6	DRAWER LOCK BRACKET	1	1220297
7	DRAWER, ROLLER SUPPORT	2	1219966
8	KIT,ROLLER,GGFV	AR	1258885

~Not Shown in the picture

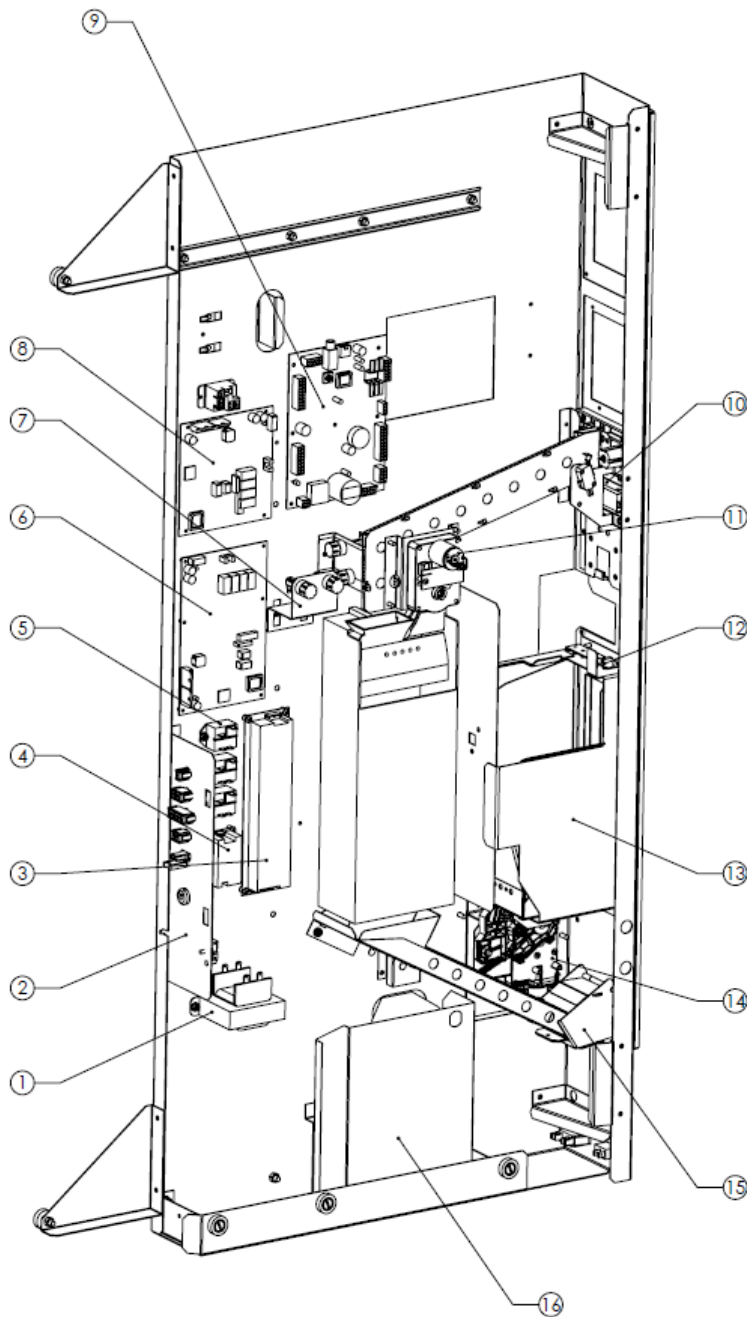
DRAWER ASSEMBLY INSIDE

ITEM NO	DESCRIPTION	QTY	PART NO
	SIDE DRAWER ASSEMBLY	1	1235478
1	TRANSFORMER,115/24	1	1111201
2	PLATE, POWER CORD,HARNESS	1	1224142
3	PWR SUPPLY,24VDC,	1	1221374

4	PWR SUPPLY,8.25V	1	1223539
5	KIT,RELAY,GGFV	1	1258869
6	RELAY BOARD	1	1222504
7	KIT,FUSE,GGFV (0.8A;250V)	1	1258877
8	DELIVERY MECH CNTL BOARD (DMC)	1	1222498
9	VEND MECH CNTL BOARD (VMC)	1	1227995-XX
10	DISPLAY / COIN RETURN	1	SEE PAGE A-9
11	COIN RETURN MOTOR MECHANISM	1	SEE PAGE A-6
12	HOPPER LED	1	SEE PAGE A-8
13	BUCKET ASSEMBLY	1	SEE PAGE A-8
14	BUCKET MOTOR ASSEMBLY	1	SEE PAGE A-6
15	COIN RETURN CUP	1	SEE PAGE A-5
16	COIN BOX	1	1088058
~	POWER BOX COVER ASSEMBLY	1	1227968

~Not shown in the picture

COIN RETURN CUP

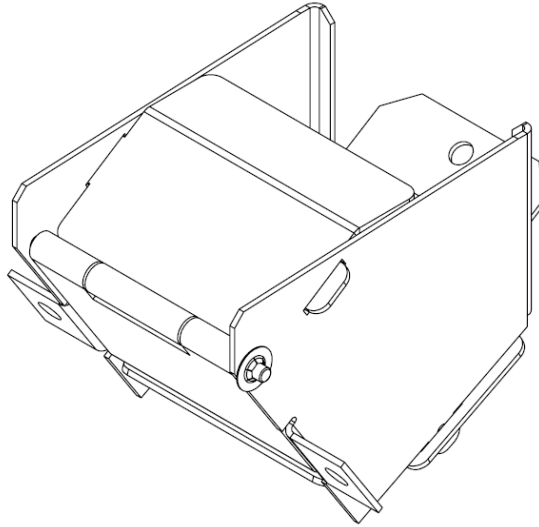

ITEM NO	DESCRIPTION	QTY	PART NO
	COIN CUP RETURN ASSEMBLY	1	1215804

COIN CHUTE ASSEMBLY

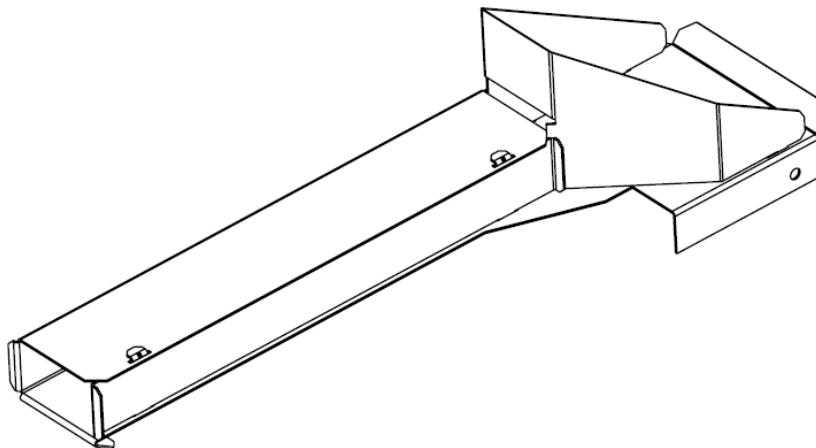

ITEM NO	DESCRIPTION	QTY	PART NO
	COIN CHUTE ASSEMBLY	1	1215813

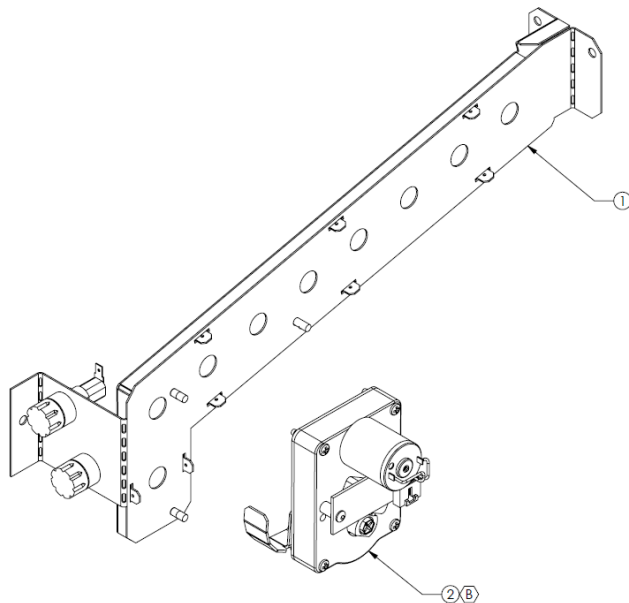
COIN RETURN MECHANISM

ITEM NO.	DESCRIPTION	QTY	PART NO
1	COIN CHUTE TOP ASSEMBLY	1	1243837
2	COIN RETURN MECH ASSEMBLY	1	1235419

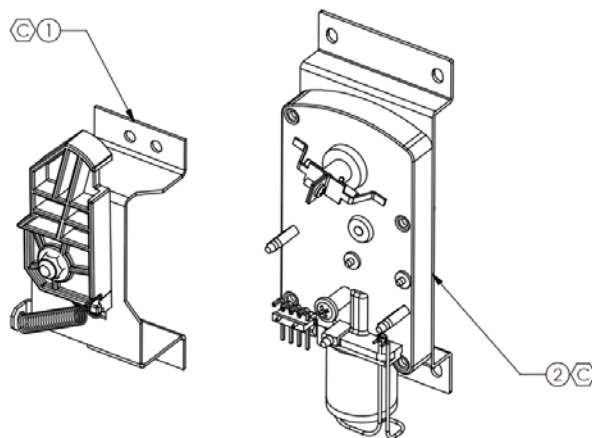
BUCKET MOTOR ASSEMBLY

ITEM NO	DESCRIPTION	QTY	PART NO
1	BUCKET MOTOR ASSEMBLY	1	1243829
2	DELIVERY BUCKET MOTOR ASSEMBLY	1	1229036

BUCKET ASSEMBLY

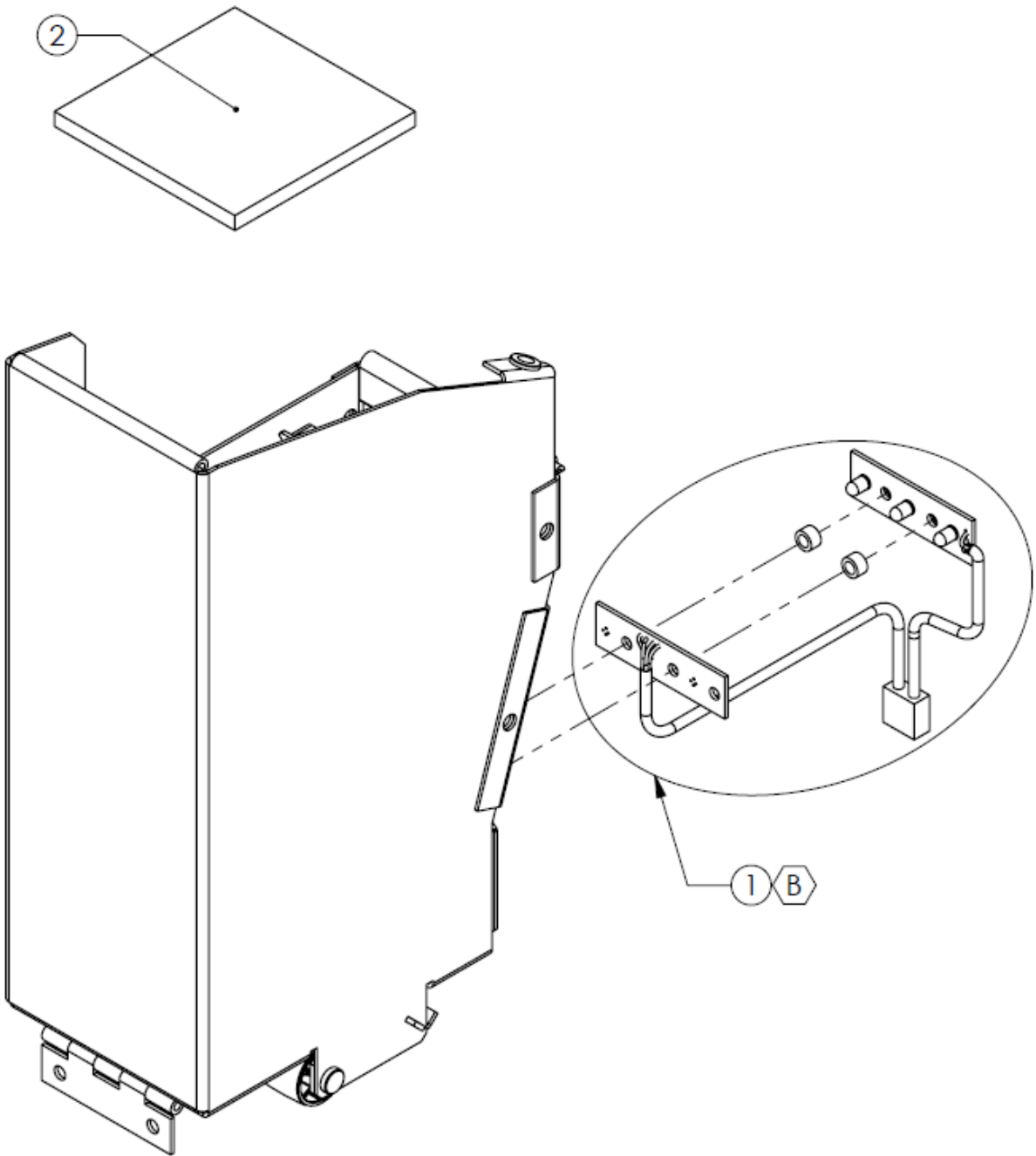

ITEM NO.	DESCRIPTION	QTY	PART NO
	FINAL ASY,BUCKET	1	1256637
1	OPTIC DETECTOR ASSY	1	1130728
2	PAD,BUCKET ASY	1	1223833

BUCKET ASSEMBLY COVER

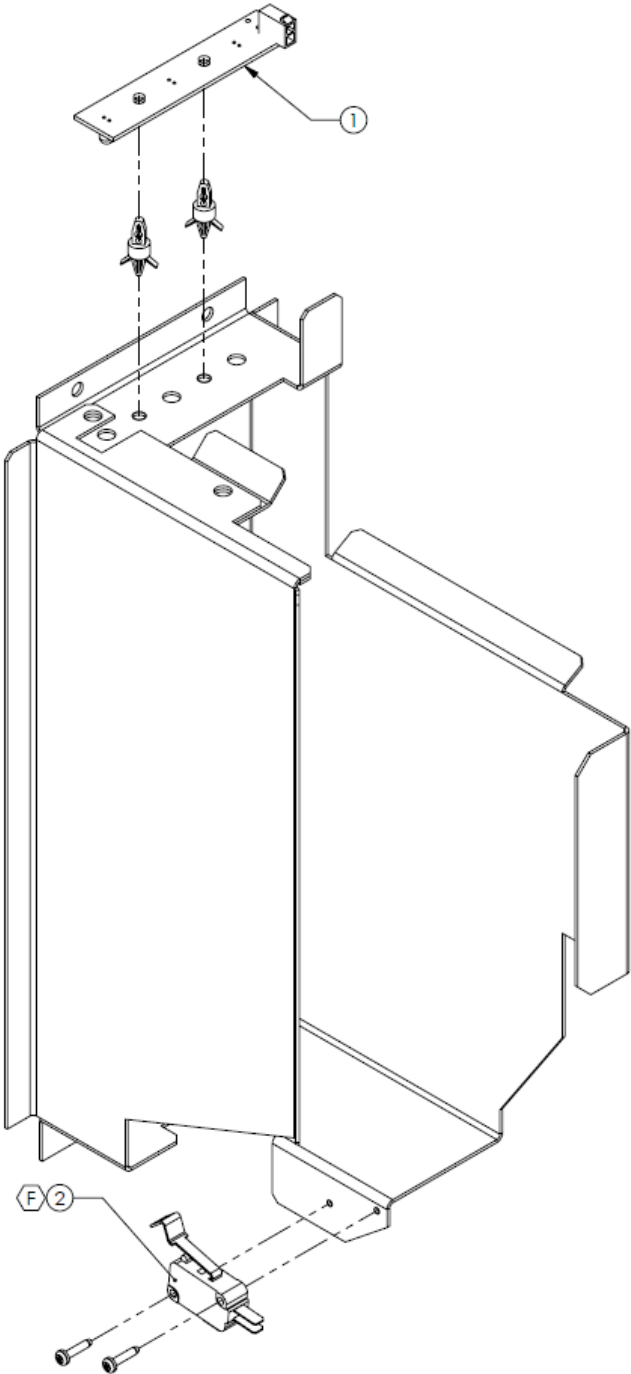

ITEM NO.	DESCRIPTION	QTY	PART NO
	BUCKET HOUSING ASY	1	1256688
1	PCBA, HOPPER ILLUMINATION LEDS	1	1130698
2	SWITCH	1	337576

ISPLAY / COIN INSERT

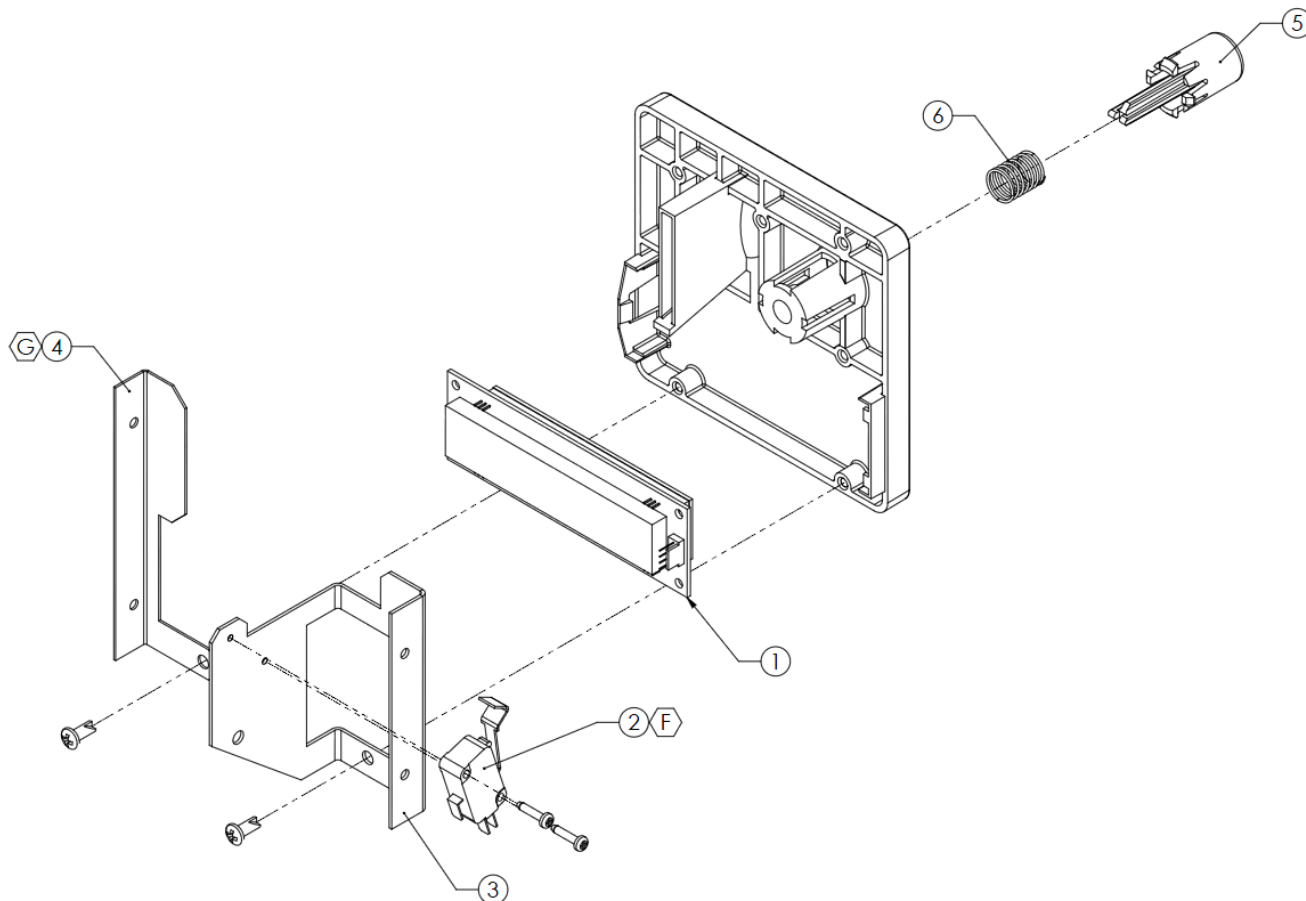

ITEM NO.	DESCRIPTION	QTY	PART NO
	KIT, COIN INSERT, GGFV	1	1259075
1	(STD) DISPLAY BOARD, LCD, 2x20 (OPTION) VFD HIGH BRIGHT, 2X20	1	1249924 1214727
2	SWITCH SEL PC	1	337576
3	BRKT, SWTCH SUPRT, COIN RTN, GGFV	1	1215288
4	BRKT, COIN INSERT SUPPRT, GGFV	1	1216196
5	BUTTON, COIN RETURN, RoHS	1	1259075
6	SPRING, SELECTION CC'93	1	1259075

*Option for High Brightness Display



TROUBLESHOOTING SECTION

PARTS RETURN PROCEDURES

1. All parts returned must be accompanied by a material return tags (P/N 1122825) Tag must clearly state the reason for the return and the Return Goods Authorization Number received from your Vendo Customer Service Rep at 1-800-344-7216. (Return tags are available from our parts department upon request).
2. All parts should be properly wrapped and packed securely to avoid further damage.
3. To replace an inoperative part, please use the following instructions
4. Complete the return tag making sure to fill in ALL requested information to ensure prompt processing. Keep top (white) copy for your records. Attach tag to inoperative part and send it by the most inexpensive method of transportation (Federal Express Ground or Overnight Transportation) **To: SandenVendo America, Inc., 10710 Sanden Drive, Dallas, Texas 75238.**
5. Be sure to check () the box marked "credit" and to fill in the invoice number covering the part sent to you or check the box marked "replace with like part".
6. If the box is marked for replace with like part, a like part will be shipped at no charge if our inspection shows that the inoperative part became defective during the warranty period.
7. If the box is marked for credit, a credit will be issued to cancel the invoice on which the replacement part was shipped. This credit will include any applicable prepaid transportation charges. To receive credit the inoperative part must be returned within 30 days from the date the replacement was shipped.
8. Vendo does not issue cash credit for the return of any part or accessory.

REFRIGERATION UNIT RETURN PROCEDURE

1. All refrigeration units returned must be accompanied by a material return tag (P/N 1122826). Tag must clearly state the reason for the return and the Return Goods Authorization Number received from your Vendo Customer Service Rep at 1-800-344-7216. (Return tags are available from our parts department upon request).
2. All refrigeration units should be properly wrapped and packed securely to avoid further damage.
3. To replace an inoperative part, please use the following instructions.
4. Complete the return tag making sure to fill in ALL requested information to ensure prompt processing. Keep top (white) copy for your records. Attach tag to inoperative part and send it by the most inexpensive method of transportation (Federal Express Ground or Overnight Transportation) **To: SandenVendo America, Inc., 10710 Sanden Drive, Dallas, Texas 75238.**
5. Be sure to check () the box marked "credit" and to fill in the invoice number covering the part sent to you or check the box marked "replace with like part".
6. If the box is marked for replace with like part, a like part will be shipped at no charge if our inspection shows that the inoperative part became defective during the warranty period.
7. If the box is marked for credit, a credit will be issued to cancel the invoice on which the replacement part was shipped. This credit will include any applicable prepaid transportation charges. To receive credit the inoperative part must be returned within 30 days from the date the replacement was shipped.
8. Vendo does not issue cash credit for the return of any refrigeration unit.

***Canadian and International customers please contact your Customer Service Representative for return instructions.**

The GGFV vendor provides self-diagnostics to aid you in the trouble shooting process. Error codes are stored in the controller's memory when a system error is sensed. These codes can be accessed in the Diagnostic section of Programming.

VMC – Vending Machine Controller **DMC**- Delivery Mechanism Controller

IMPORTANT INFORMATION:

General Process Description:

Ready to Vend Position: The catcher is at the bottom corner towards the hinge side of the machine – the fork on the catcher is pointing towards the trays.

Initialization Process: This process is activated during power up and Door Close scenario.

The catcher will rotate 90 Degrees clockwise, to confirm Z movement.

The catcher will move sideways about 3 inches away from the hinge side and will move back to the original position – to confirm X- location.

The catcher will move up about 4 inches and back to the base – to confirm the Y-location.

The catcher will perform a vend drop movement – to confirm that there is no product in the catcher.

The catcher will move up along the hinge side of the machine then towards the right and diagonally back to the original position – to confirm the shelf locations.

The catcher will rotate 90 degrees anti-clockwise to return to the Ready to Vend Position.

Recovery Process: This process is activated anytime there is a physical obstruction during the catcher or elevator movement. The vendor will initiate the initialization process on any motor jam. The vendor retries 5 times before terminating the recovery process. If the vendor fails to recover during its 5 retries, the machine is out of order.

The trouble shooting section contains Error Codes and General Machine Troubleshooting.

Elevator Trouble Shooting Guide

ERROR TYPE	DESCRIPTION OF ERROR CODE	ROOT CAUSE	CHECKING METHOD	CORRECTIVE ACTION
Products Dropped	Products laying on the catcher or Rail	The release mechanism in the catcher did not work	Check the product release “u-shaped stopper” on the delivery eyelet	Adjust the U-shaped stopper towards the hinge side of the machine. Technical Bulletin Available.
			Check the X-Roller Bracket on the left side of XY Rail to make sure it’s making contact with the inner liner of the cabinet during the product drop.	Raise the X-rail to the eyelet position, adjust the X-roller so it’s slightly making contact with the inside liner.
			Check X – Belt tension.	If the belt needs tightening, use the right side screw on the rail to tighten it. Technical Bulletin Available.
			Check the X ribbon cable underneath the catcher.	Remove the catcher from the base and confirm the X-ribbon cable is not creased. Check continuity on the ribbon cable. Confirm the ribbon cable is routed from the cutout further away from the hinge side of the machine. Technical Bulletin Available.
Products Dropped	Products not advancing	Back pusher did not disengage from the lock mechanism	Make sure the product pushers have disengaged after loading	Disengage the pusher – Make sure the back sheet metal strip is not bent
		Pusher sticking in its guide	Dust particle in the guide	Move the pusher on its track to remove all dust particles. Clean the pusher path / re-apply grease
Products Dropped	Product(s) in the XY Rail	Incorrect loading of product. If the bottles lean forward, it is knocked off the column by the rail as it moves to vend another product.	Make sure the products are not tilting forward after a product reload.	Load the bottles correctly. Pull the tray - Push and lock Spacer to the back. Load products from behind. Push the tray in place- the pusher will automatically snap back (see decal on top drawer panel)
XY Failure	Display reads - "Now dispensing" the XY rail does not move.	The flap is not fully closed.	Check for any interference blocking the flap	Remove any interference
			Make sure the flap pivot is not tight and preventing the flap from closing	Loosen the top two screws on pivot pin.
			Check for the LED Hopper light harness connector is not in the way of flap close	Wire tie the harness away from the flap
		The magnet on the flap is missing / fallen off	Check the back side of the bottom middle part of the flap for a magnet	Replace the flap or Re-insert the magnet if it has fallen off.

ERROR TYPE	DESCRIPTION OF ERROR CODE	ROOT CAUSE	CHECKING METHOD	CORRECTIVE ACTION
XY Failure	XY Rail moves to a location and stops abruptly : Error Code " Axis Motor Locked: Y"	The counter weight is dragging along the side brackets - causing the Y motor to overload	Turn off the power. Run the XY Rail up and down to see if there any obstruction - The Rail should run freely and evenly at the both ends of the elevator	Check for proper installation of the elevator - Lubricate the track
XY Failure	XY Rail moves to a location and stops abruptly : Error Code " Axis Motor Locked: X"	The catcher is not able to move in X direction	Turn off the power. Push the catcher towards the bucket side to check for any any obstruction - Repeat the same checking method towards the hinge side of the machine.	Remove any physical obstruction.
		Damaged Ribbon Cable	Check the X ribbon cable underneath the catcher.	Remove the catcher from the base and confirm the X-ribbon cable is not creased. Check continuity on the ribbon cable. Confirm the ribbon cable is routed from the cutout further away from the hinge side of the machine. Technical Bulletin Available.
		X - Motor not working	The X motor is defective	Change X motor
XY Failure	XY Rail fails to move up during initialization and the teeth slipping at the Y-motor gear		Check for any gear breaks at the Y Motor area	Change Y motor or Y Motor assembly or elevator gear
XY Failure	Error Code: Axis Motor Locked Jammed between Shelf # X and Y	The XY rail jammed between Shelf X and Y where X and Y are actual shelf number (top one being # 1)	Move the Rail to the top of the machine and let it drop down - Check for any interference in the shelf locating U-Shaped sensor and the shelf tab at the right side of the shelf	Bend the shelf tabs so that it passes through the center of the U-shaped sensor
			Check for any bottle tipping towards the door	Check the product gates are working properly.
X Failure	Catcher Moves to the right and does not move back - error code : Switch Off	The X-Sensor in the X-Rail assembly is not working	check to make sure there is no debris in the X-Home sensor and retest	Change the X-Rail or X-Home Sensor
Z Failure	No movement on the catcher	No power to the motors	Check the fuse on the 24 v power supply	Change fuse if blown
	Vendor picks up a product but keeps on rotating the catcher unable to move towards Drop location	Failed on catcher rotation	Check continuity on the ribbon cable - the wires are broken	Change the ribbon cable Technical Bulletin Available.
Bucket	Bucket opening and closing after a vend	Bucket base is not engaging the bucket base switch	Make sure to check the harness and connectors are out of the bucket path	
		Bucket side is hitting the door side while opening	Check the bucket side for any scraping	Appropriate measure to avoid the scraping

ERROR TYPE	DESCRIPTION OF ERROR CODE		CHECKING METHOD	CORRECTIVE ACTION
Bucket	Bucket stays open after a vend	The bucket vend optics have been blocked	Check for any debris inside the bucket	Remove debris and wipe the inside of the bucket to remove any dirt
Y Switch	During initialization , Y Rail Moves down and pushes down when it reaches the bottom - led light turns off momentarily	The rail is trying to push down although it is physically at the bottom	Y -switch not working or not activated	check the y switch
Operator	Error Code "Door Opened - Movement"	The door was opened while the elevator was in motion	This is a flag to indicate that the door was opened during movement	Reset the error Code
Door Switch Mismatch	Door Switch signal between the VMC and DMC board does not match	Door Switch mis-wired	Make sure the door switch is wired correctly – Refer to Wiring Diagram	Correct wiring on door switch
DMC not Available	The VMC and DMC communication broken No power to DMC	Communication link disconnected or not working	Check the Y-MDB plug from VMC is connected to the DMC controller	Replace harness if the wires are broken.
		Fuse Blown	Check the fuse for the DMC board	Replace fuse if necessary
		No power to DMC board	Check 8v power supply and make sure there is power into the DMC board (refer to wiring diagram)	Replace power supply if necessary
	DMC Board Defective	DMC board is not working	Replace DMC board if necessary	
Vending Wrong #	Selection # not matching the shelf #, eg. Pressing 11 vends 21 , 22 vends 32	DMC did not detect the correct number of shelves in the vendor	Check the Shelf position under diagnostics and confirm the distance of each shelf from the bottom tray.	If # of shelf shown is less than the actual then the sensor did not detect one to the shelf. Look for missing shelf tab and confirm the U sensor passes in between the shelf tab during initialization process. Confirm the shelf tabs covers more than half of the U-sensor during the shelf scanning process. Replace U-Sensor if required.
X/Y Failure	Jerky Movement on X/Y direction	Wire not connected properly Wire not connected tightly in place at the board Wire not connected at the back of the drawer	Check the connectors in the DMC board and Relay board are connected properly and locked into its housing. Perform a pull test on the wires to make sure they are locked in its pin slots.	Re-connect the connectors into its corresponding housing. Re-connect the pins in its housing. Replace the harness if required.

General Machine Troubleshooting

ERROR	PROBABLE CAUSE	CORRECTIVE ACTION
COIN ACCEPTANCE/PAYOUT (Record all errors for reference if Vendo Technical Service is required)		
Coin mechanism will not accept coins.	No power to control board.	Check to make sure the red LED on the control board is flashing red. If flashing, check MDB harness connections. If connections are good, replace changer.
	Harness from coin mech to board is cut or disconnected.	Use a meter and check each wire for continuity and ground.
	Short in coin mechanism.	Replace coin changer/acceptor.
	Acceptor is dirty or other problem may exist (not tuned).	Clean acceptor or contact your local coin mech dealer.
	Defective control board.	Replace control board.
No acceptance or rejects a percentage of good coins.	Coin return lever pressing down on acceptor's coin plunger.	Make sure changer is mounted correctly and the coin return lever is in the proper position.
	Acceptor is dirty or foreign matter is in the path.	Clean acceptor or contact dealer.
	Coin changer is improperly tuned (if tunable).	Contact manufacturer for tuning.
	Defective controller board.	Replace/test controller.
Always accepts coins but gives erratic/no credit.	If NO CREDIT: Defective harness between coin mech and control board (will have "CC" error).	Check harness for cut wires or wrong/bad connections. Test each wire for continuity or test to ground. If found to be defective, replace.
	If ERRATIC OR NO CREDIT: Acceptor or coin mech.	Replace coin mech and test.
	If NO CREDIT: Defective controller.	Replace/test controller.

ERROR	PROBABLE CAUSE	CORRECTIVE ACTION
Changers will not payout coins.	Defective harness between coin mech and control board.	Test vendor's manual coin payout. If vendor won't pay out using the Coin Payout mode or during sales, check harness for cuts, bad continuity or wrong connections. If defective, replace and test.
	Defective coin mech.	Replace coin mech and test.
	Defective controller board.	If coin mech won't payout coins manually in the Coin Payout mode or during the Sales Mode and the above two procedures have failed, replace the control board and test payout both in the Coin Payout mode and during a sale.
	Changer payout buttons are disabled while door is closed or while in Open-Door Sales Mode.	Enter the Service Mode or access the Coin Payout Mode.
BILL ACCEPTANCE		
Bill Acceptor will not pull bill in.	No power to validator.	Unplug power. Wait for 10 seconds. Reconnect power and see if bill acceptor cycles. If not, check acceptor harnessing or replace the bill acceptor.
	Acceptance disabled by coin mech (if present), or bad harnessing.	Make sure that the coin mech is plugged in (accepts coins) and that the coin tubes have enough coins to enable bill acceptance.
	Coin mech is not operative.	Make sure that the changer harnessing is correctly connected and has continuity. Repair or replace if necessary.
	Replace acceptor and test.	If acceptor accepts, bill acceptor was defective.
Bill acceptor takes a bill but does not establish credit.	Defective acceptor harness (credit not getting from acceptor to control board through the harness).	Make sure that the acceptor and harnessing is correct for your style of acceptor and it is plugged in and wired properly.
	Defective acceptor.	Replace/test acceptor.
	Defective controller.	Replace/test controller.
Bill acceptor takes a bill and credits but not erasing credit.	Defective bill acceptor.	Replace acceptor and test acceptance and erasure of credit.
	Defective controller.	Replace/test controller for erasure of credit.
	Both vend sensors are defective	Replace vend sensor.
Acceptor takes a bill and allows payback of coins without a selection.	Controller's configurations not set properly.	Access vendor configuration mode and check the "Forced Vend" setting.
MISCELLANEOUS PROBLEMS		
Vendor appears dead; no digital display and no lights.	Defective main harness.	If red light on control board is off, check fuse and transformer.

No digital display; vendor lights on.	Defective display or display harness.	Check display and display harness. Replace if necessary.
	Check for a flashing red light on control board.	If no light, replace control board.
Vendor scrolls message on display but does not accept money.	Changer out of tune.	See "Tuning Changer".
	Defective changer.	Replace changer.
	Defective controller board.	Replace control board.
ERROR	PROBABLE CAUSE	CORRECTIVE ACTION
Vendor accepts money but does not display credit.	Defective changer.	Replace changer.
	Defective controller board.	Replace board.
Vendor accepts and credits money but does not vend (does not indicate a sold-out).	Defective selection switch.	Replace switch.
	Defective selection switches harness.	Repair or replace harness.
	Defective controller board.	Replace board.
REFRIGERATION		
Refrigeration unit will not run.	Defective temperature sensor.	1. Check connection. 2. Replace temperature sensor.
	Defective control board.	Replace board.
Refrigeration unit will not run at all.	No power to vendor.	Check power supply, also check service cord connections.
Unit will only run in the compressor relay test mode. (Located under Test Mode)	Defective cabinet switch.	Open and close the door to make sure lights and fan come on. If not, then check the cabinet switch.
	Defective temperature sensor.	Follow the same steps detailed above about the temperature sensor.
	Wait the 3 minute delay once the cabinet door is closed.	Wait to see if unit comes on.
	Defective control board.	If unit still does not come on, then replace the control board.
Unit will not run in the compressor relay test mode. **NOTE: Leave the compressor relay test mode on, in order to check for voltage.	Defective control board.	Unplug unit at power distribution panel. Remove air dam. Reconnect power. Enable compressor relay through Test Mode. Check 2-pin connection on power distribution for 110V.
	Defective relay.	Upon opening the cabinet door, the lights and fans should shut off. If they don't, replace the cabinet switch.
Refrigeration unit runs constantly.	Defective cabinet switch.	Upon opening the door, the display should read either errors, summary sales, or none. If it does not, then replace the cabinet switch.
	Defective control board.	Replace control board.
	Defective relay - contacts are welded together.	Replace relay.
Compressor will not start.	Overload protector inoperative.	Check overload (apply insulated jumper across terminal, if compressor starts, replace overload).
	Defective cabinet switch.	Check for error codes. Replace cabinet switch.
Compressor will not start, condenser fan motor running - unit hot (power to compressor).	Defective over load relay	Replace the over load relay.
	Compressor motor rocked	Replace the refer unit
	Defective capacitor	Replace the capacitor.

Compressor starts but does not run.	Defective PTC relay	Replace the PTC relay.
	Loss of refrigerant	Replace the refrigeration unit.
	Smashed tubings and capillary	Replace the refrigeration unit.
	Defective over load relay	Replace the over load relay.

ERROR	PROBABLE CAUSE	CORRECTIVE ACTION
Compressor runs but cabinet temperature warm.	Loss of refrigerant	Replace the refrigeration unit.
	Smashed tubings	Replace the refrigeration unit.
	Defective drainage	Make sure the drain hose is not kinked or clogged.
	Defective temperature sensor	Replace the temperature sensor.
	Poor air flow	Make sure nothing is sitting in front of the evaporator.
	Defective control board	Replace the control board.
	Defective door seal	Make sure the vend flap and gasket are not open.
Both compressor and condenser fan motors will not operate.	Defective heat exchange on condenser/ Blocking air flow by dust, lint or fins damage	Clean the surface of the condenser fins or straighten the bent fins.
	Bad refrigeration control relay.	Test relay using relay test function of the electronic controller. Replace relay if necessary.
	Bad connection at power board.	Check wiring connections. Make corrections if necessary.
Evaporator frosted over.	Loss of refrigerant	Replace the refrigeration unit.
	Smashed tubings	Replace the refer unit.
	Defective drainage	Make sure the drain hose is not kinked or clogged. Re-install hose correctly if kinked or clogged.
	Defective temperature sensor	Replace the temperature sensor.
	Defective control board	Replace the board.
	Poor sealing	Check gasket, vend flap, and permagum on the bulkhead.
Product freezing up (too cold).	Temperature setting too low.	Adjust set point in control board.
	Defective temperature sensor	Replace the temperature sensor.
	Defective control board	Replace the control board.
Excessive noise.	Fan blade hitting shroud or transformation or loose fitting	Replace the fan blade or re-install correctly.
	From the inside of fan motor or loose fitting	Re-install or replace the motor.
	From the inside of compressor or loose fitting	Replace the refrigeration unit.

Error Codes

Error Codes are flagged if the vendor detects an error during its operation.

Procedure to view error codes:

1.Open the door 2.Press Mode Switch 3.Display will read "Diagnostics" – Press 4 to view top level error – Press "4" again to view the detailed error

ERROR CODES	DESCRIPTION OF ERROR CODE	CHECKING METHOD	CORRECTIVE ACTION
Product Catcher – Y-Rail : Top level Error : DMC Error			
Excessive Pulse	Motor Encoder pulse is more than expected	Power Up and Initialize the vendor	Replace Related Motor.
Pulse Stop	Motor Encoder cannot detect the encoder signal	Check for wire continuity between the motor pins and the DMC board (Ref wiring diagram)	Replace harness if necessary.
		Motor Disconnected	Re-connect motor
		Motor Malfunction	Replace Motor
Switch On	Motor Home Switch Always On	Power Up and Initialize the vendor – Check to see the Home switch is connected	Re connect home switch
		Switch Malfunction	Replace Home switch
Switch Off	Motor Home Switch Always Off	Power Up and Initialize the vendor – Check to see the Home switch is connected	Re connect home switch
		Switch Malfunction	Replace Home switch
Axis Motor Lock: X/Y/Z	(X/Y/Z) Motor failed to move	Reset power – Let it finish its initialize or recovery routine. Open the door and check error code for related motor failure	Details Below
Axis Motor Locked: X Mtr Jam at Tray #	X Movement Failed around Tray #	Check for obstruction on X-rail (Screws / Debris)	Remove any obstruction – Test Replace Motor if necessary
Axis Motor Locked Y Jammed between Shelf # and #	Y Movement Failed	Checks for any obstruction on Y-Rail – Common reasons are and not limited to interference between the Shelf Sensor and Sensor Tabs.	Re-adjust the tabs so that the U-sensor does not interfere during the initialization. Adjust the X-Roller Bracket if necessary
	The XY rail jammed between Shelf # and # where # is actual shelf number (top one being # 1)	Move the Rail to the top of the machine and let it drop down - Check for any interference in the shelf locating U-Shaped sensor and the shelf tab at the right side of the shelf	Bend the shelf tabs so that the it passes through the center of the U-shaped sensor
		Check for any bottle tipping towards the door	Check the product gates are working properly.
		Unable to move elevator	Remove any obstruction – Test Replace Motor if necessary
Axis Motor Locked	Z Movement Failed	Check for any obstruction in Z-direction	Remove any obstruction – Test

Z Motor Jam			Replace motor if necessary
Shelf Not detected	Shelf not detected during initialization	Power Up and Initialize the vendor	
		Check U-Sensor Connectivity	Confirm U-sensor connectivity
		Confirm the shelf tabs are installed	Install shelf tabs
Shelf out of Range	Shelf detected is out of shelf position limits	Power Up and initialize the vendor	Confirm connectivity of the U-sensor in the Y-Rail.
			Check to make sure the U-sensor passed through the shelf tabs during initialization.
ERROR CODES	DESCRIPTION OF ERROR CODE	CHECKING METHOD	CORRECTIVE ACTION
VMC Error : Top Level Code : VMC Error			
Escrow Motor Switch	Coin Return motor switch not working	Check connectivity on the Coin Return motor switch.	Change harness if required
		Plug in coin return switch connector. Press Coin Return Button. Confirm the motor moves full 360 Degrees in clockwise direction. Test it twice to make sure the cam stops at exactly the same position.	Check the Coin Return Switch and change if necessary
Escrow Motor Jam	Coin Return Motor not working	Check for any obstruction on the coin return mechanism that might prevent the cam rotation. eg. Wire harnesses	Clear obstruction and test. Change motor if necessary
Hopper Bucket Switch	Hopper Bucket Switch not working	Check connectivity on the hopper bucket motor harness	Change harness if necessary
		Check that the hopper switch is connected	Connect switch
		Bucket switch stuck due to syrup on the switch	Change motor assembly
Hopper Bucket Jam	Hopper bucket motor not working	Check to see if the bucket Cam is broken	Replace bucket cam if broken
		Unlock the bucket cam and push the bucket open Test hopper in test mode with bucket pushed open – the bucket open cam should turn clockwise and stop for 2 seconds and return back to original position	If the bucket motor cam does not run as described – change the motor
Hopper Base Switch	Hopper did not close properly	Test hopper operation in test mode – The hopper should open – wait for 2 seconds and close. The display should read “Hopper Test Successful”	
		If the hopper test fails -	Check for connectivity of hopper switch wire
			Check for any interference that could prevent the activation of hopper base switch lever – eg. Optics harness
			Check to make sure the hopper base switch is properly connected
Escrow Switch	Coin Return switch not working	Press Coin Return switch – the coin return motor should turn 360 Degree clockwise	Check connectivity on the coin return switch , Make sure the switch is connected properly and the coin return button activates the switch
Escrow Mtr No Cur	No power to the Coin Return motor	Press coin return button to test	Check to make sure the Coin Return motor connector is connected
			Replace motor if necessary
Hop. Buck No Current	No power to the Coin Return motor	Test Hopper operation	Check to make sure the Hopper motor connector is connected
			Replace motor if necessary

ERROR CODES	DESCRIPTION OF ERROR CODE	CHECKING METHOD	CORRECTIVE ACTION
Selection Switches – Top Level Code : Selection Switch Error			
Stuck Selection SW on Keypad	Bad Selection Switch - Selection switch within the Keypad is actuated for more than 15 seconds while in the Customer Mode or Door Open Sales Test Mode.	Check the selection switch number shown in the detailed error code “nn” to see if: 1) if the Keypad is defective; 2) the harness is wired wrong/shorted	Try to correct the problem if one of the two items is found. If you can't correct it, then replace the component in question.
Coin Changer : Top Level Code: Coin Changer Error			
Coin Communication	Changer communication error - no changer communication for more than 2 seconds.	Check that red light is flashing on control board.	If light is not flashing, there is no power to board. Check and replug any unplugged connections.
		Check fuse on the power distribution panel.	If fuse is blown replace it.
		Defective acceptor.	Replace acceptor.
Tube Sensor	Tube sensor is defective - reported by changer	Check changer tubes for blockage	Clear tube blockage. If no blockage is found, replace changer.
Coin Inlet	Changer inlet chute blocked - no coins sensed for over 96 hours by the changer.	Check inlet chute for blockage. Drop coins in Sales Mode or Tube Fill Mode to test acceptance. Manually clear the error.	Clear inlet chute blockage. If no blockage found, replace changer. If acceptance rate is acceptable, system is OK. If acceptance rate is low or changer will not accept coins, replace changer.
Tube Jam	Tube pay out jam – reported by changer.	Check changer tubes and payout for blockage.	Clear blockage, if found. If no blockage is found, replace changer.
Coin Read Only Memory	Changer check sum incorrect - reported by changer.	Unplug machine, wait at least five seconds, replug machine. Manually clear the error	If error does not clear, replace changer/acceptor.
			Replace acceptor
Excessive Escrow	Excessive escrow requests - more than 255 requests since the last coin was sensed.	Check escrow lever and associated mechanisms.	Manually clear the lever and error.
		Close door then reopen. Check to see if error still occurs.	Replace changer/acceptor.
Coin Jam	Coin jam - reported by changer	Check changer/acceptor for jammed coins or other obstructions.	If no obstructions are apparent, replace changer/acceptor
Low Acceptance	Low acceptance rate – coin acceptance has fallen below 80%	Check changer/acceptor for obstructions or dirt	If no obstructions are apparent, and acceptance appears to be OK, this may be an indication of cheating attempts.
		Drop coins test acceptance.	If no obstructions are apparent and coins do not accept, or acceptance rate is poor, replace changer/acceptor.
Accept Disconnect	Disconnected acceptor - indicates that an acceptor is unplugged.	Check coin mechanism plugs. Check for faulty harness wiring (see wiring diagram for circuit).	Correct connections.
Routing	Coin routing - indicates a coin was routed incorrectly.	Verify acceptor set-up using manufacturer's recommendations.	If acceptor was set up correctly, replace acceptor.

ERROR CODES	DESCRIPTION OF ERROR CODE	CHECKING METHOD	CORRECTIVE ACTION
Dollar Bill Validator : Top Level Code : Bill Validator Error			
Bill Validator Communication	Bill validator communications - No bill validator communication for 5 seconds.	If changer or card reader is being used, check for "CC" or "rC" errors.	If there are no "CC" or "rC" errors: 1) Check bill acceptor harness; 2) Replace bill acceptor. If there is a "C" or "rC" error: 1) Check control board MDB harness.
		Turn off door switch and wait at least five seconds. Turn on door switch.	
Bill Validator Full	Bill validator full – reported by validator (STACKER command).	Insure bill cashbox is empty and that the cashbox is properly closed and in place.	If cashbox appears to be OK, replace bill acceptor.
Bill Validator Motor	Bill validator motor is reported as defective by validator.	No test available	Replace bill acceptor.
Bill Validator Jammed	Bill jammed - reported by validator.	Check bill validator for obstructions or dirt.	If no obstructions are apparent, replace bill validator.
Bill Validator ROM	Bill validator check sum is incorrect.	Turn power switch off. Wait at least five seconds. Turn power switch on. Manually clear the error.	If error does not clear, replace bill acceptor.
Bill Validator Open	Bill validator is open.	Check that bill cashbox is closed and in correct position.	If cashbox appears to be OK, replace bill acceptor.
Bill Validator Sensor	Bill validator sensor is not functioning.	Check bill validator for obstructions or dirt.	If no obstructions are apparent, replace bill validator.

Card Reader : Top Level Code: Card Reader Error			
Card Reader Communication	There is no card reader communication for 5 seconds.	If card reader/bill acceptor is being used, check for "rC" or "bC" errors.	If there is no "rC" or "bC" error: 1) Check changer harness. 2) Replace changer.
		Turn power switch off. Wait at least five seconds. Turn power switch on.	If there is a "rC" or "bC" error: 3) Check control board MdB harness.
Card Reader	Most recent "non-transient error" from the card reader.	No test available.	Refer to card reader manual for corrective action.
Refrigeration : Top Level Code : Refrigeration Error			
Temp Sensor	The temperature sensor is defective or unplugged.	Check to see that temperature sensor harness is plugged into door harness at air dam area.	If the sensor is unplugged, replug it.
		Check for temperature sensor connection J7 on control board is plugged in.	If the connection is unplugged, replug it.
Compressor	System has failed to decrease temperature 1° per hour while the compressor is running.	Check refrigeration settings (refer to refrigeration section of programming manual).	Change settings as required.
		Check if evaporator is frozen.	Check seal around cabinet.
		Verify evaporator fan is running.	Check harness to fan motor and check output voltage.

ERROR CODES	DESCRIPTION OF ERROR CODE	CHECKING METHOD	CORRECTIVE ACTION
Miscellaneous Error : Top Level Code : Other Error			
Door Switch	Outer door has been open for more than one hour.	Check the vendor's door switch to see if it's sticking or miswired.	Replace the door switch, if defective.
Ram Error	Ram check sum for service mode settings stored in nonvolatile memory has been corrupted.	No test available.	If error shows up frequently, replace the control board.
AC Low	AC voltage to the controller is less than 20Vrms for more than 30 seconds.	Check for low voltage at the wall outlet at unit start-up.	Contact a qualified electrician.
Scale	Scaling Factor error – one of the credit peripherals has introduced a scaling factor that is not compatible with the current configuration.	Check the connections of changer harness; make sure changer is plugged in and working.	Make corrections to harness or replace the changer if necessary.
Inlet Sensor	Machine's coin inlet sensor is blocked for more than 1 minute.	Check changer harnessing for cut, pinched or crimped wires.	Replace harnesses or changer.
Escrow Return Mech.	3 successive coins are detected at the inlet but do not make it into the changer in 10 seconds.	Check inlet for blockage. If nothing is found, check changer harnessing for cut, pinched or crimped wires.	Clear blockage or replace harness or changer.
Flap Open / Flap Swt	Flap Opened before vending	The Vending mechanism will not work if the flap is open before vending	Check to make sure the flap is closed. Check to make sure there is no obstruction during flap open / close eg. Wiring for hopper optics.
	Flap Switch Malfunction	Check to make sure the flap switch is connected Check the flap hinge	Connect flap switch if it is disconnected. Confirm the flap is closed
Door Switch Mismatch	The VMC and DMC door signal did not match	Door Switch faulty or mis-wired. Check wiring diagram for correct wiring	Reset Error – Re connect the connectors in right orientation. Replace door switch if necessary
Door Opened - Movement	The door was opened while the elevator was in motion	This is a flag to indicate that the door was opened during movement	Reset the error Code



DOOR PARTS SECTION

DOOR ASSEMBLY

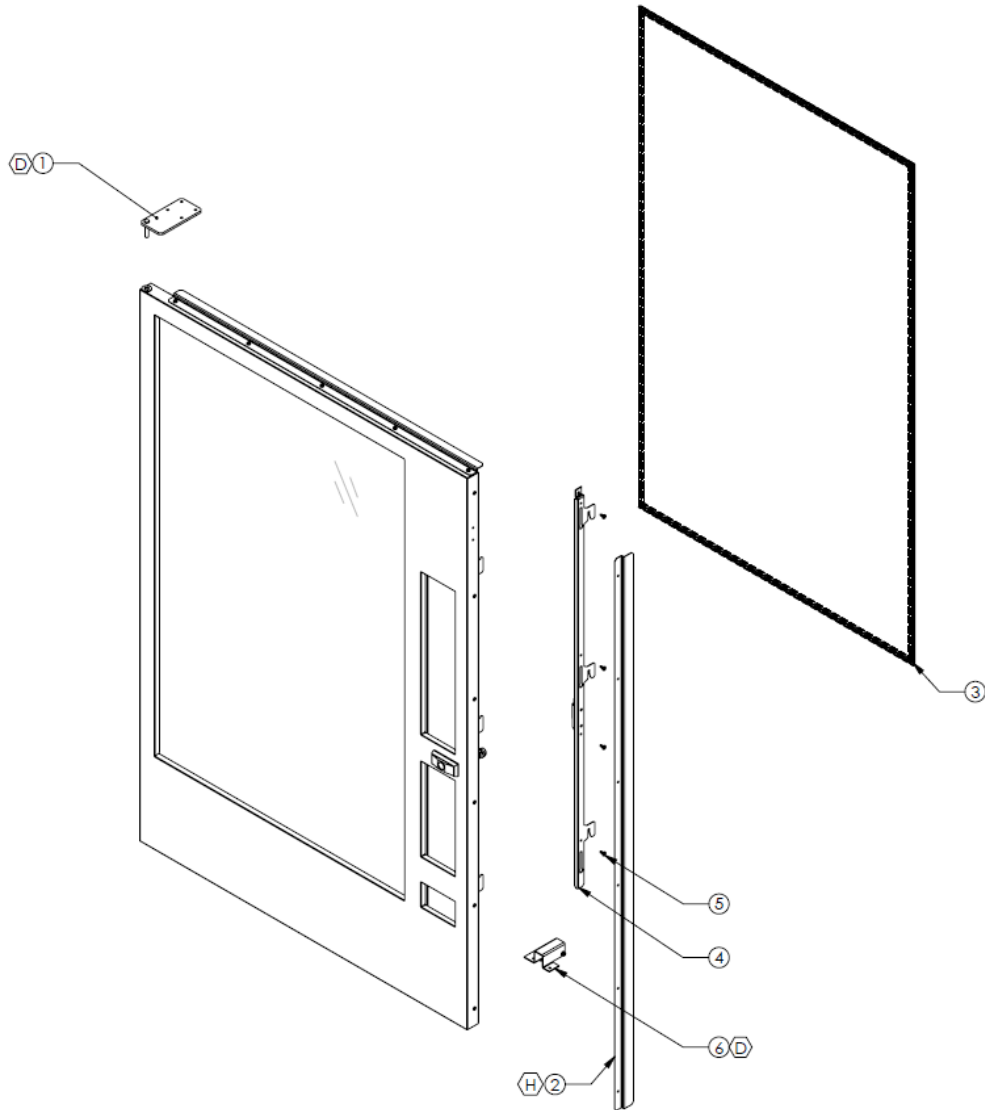

ITEM NO.	DESCRIPTION	QTY.	PART NUMBER
	FINAL DOOR ASSEMBLY,GF-9	1	SEE CHART ON PAGE B-3
1	ASSY, UPPER HINGE, GGFV	1	1216347
2	DOOR GUARD,GGFV	1	1237586
3	GASKET,DOOR ASY,40",GGFV	1	1215626
4	ASY,WELDMENT,SLIDER BAR,GGFV	1	1235982
5	GLIDE, NYLON, GFV REFER DECK	1	1126532
6	ASY,DOOR ROLLER,GGFV	4	1215662

DOOR DECAL / BRANDING CHART	
PART NO	DESCRIPTION
TBD	NO LABELING
1251872-3	TRADE DECAL
1251872-2	PEPSI DECAL
1251872	AQUAFINA DECAL
1251872-1	STARBUCKS DECAL
TBD	COKE DECAL

T-HANDLE LOCK ASSEMBLY

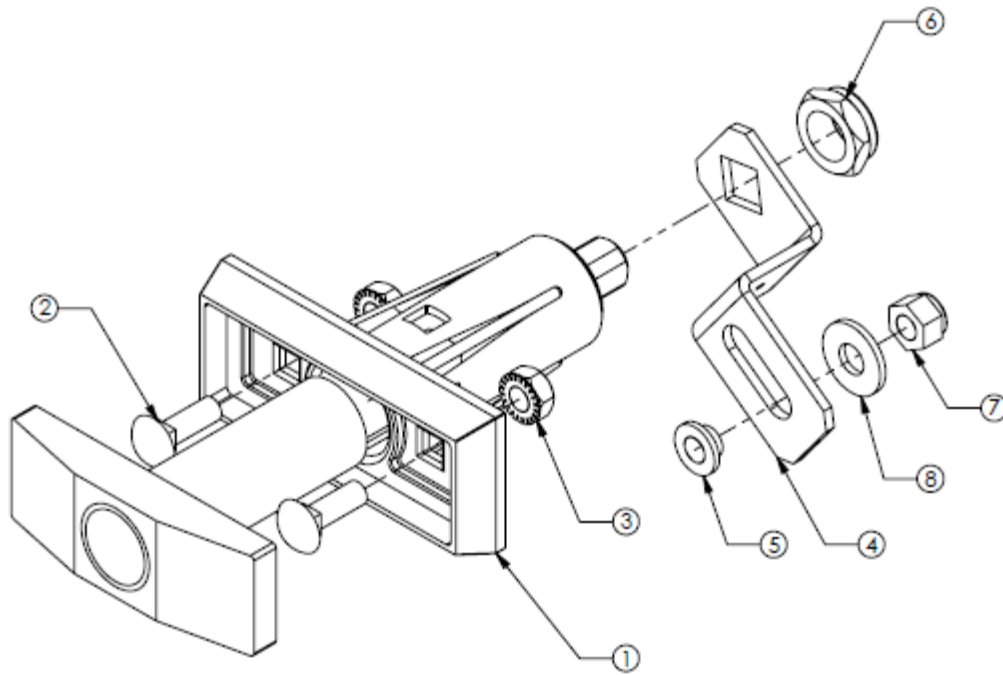

ITEM NO	DESCRIPTION	QTY	PART NO
	INSTALL,T-HANDLE,KL62	1	1237314



ELEVATOR & CATCHER PARTS SECTION

ELEVATOR COMPONENTS

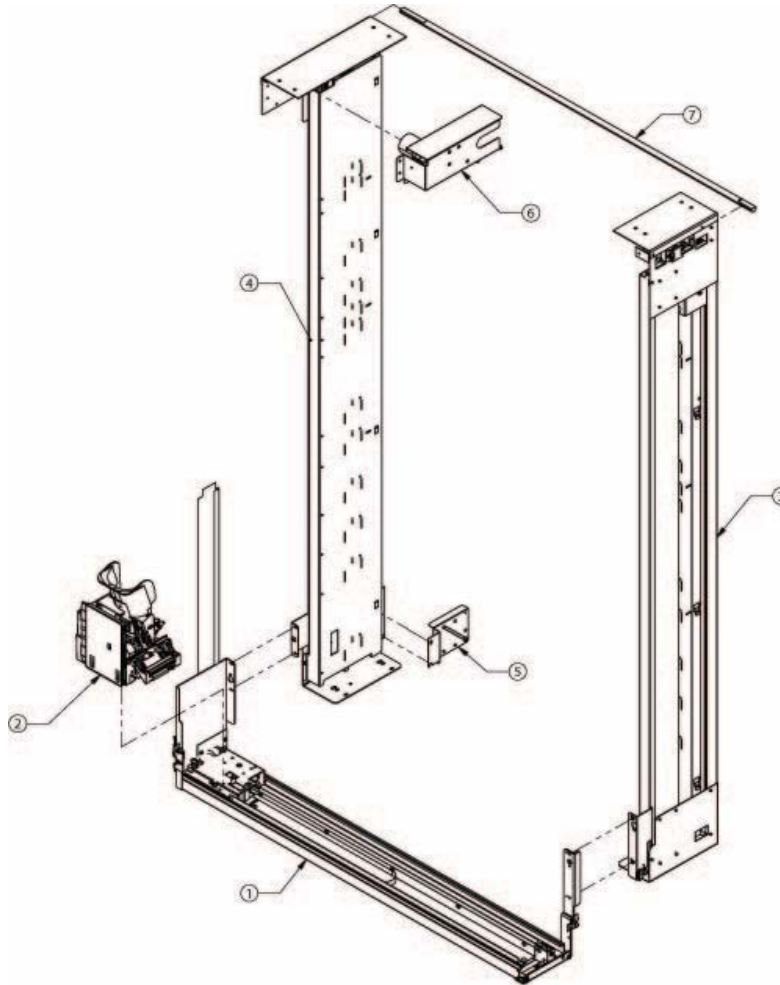

ITEM NO	DESCRIPTION	QTY	PART NO
1	Complete X-Rail Assembly	1	1246917
~	X-BELT CLIP	1	1259113
~	SENSOR , SHELF CONFIGURATION	1	1243675
~	RIBBON CABLE,X-RAIL ASSY,GGFV	1	1247824
2	ASY,CATCHER – PRODUCT DELIVERY	1	1222442
3	ELEVATOR, RIGHT SIDE ASSY	1	1243543
4	ELEVATOR, LEFT SIDE ASSY	1	1243578
~	SWITCH,Y-HOME	1	1234846
5	PCBA TERMINAL ASY,X-AXIS	1	1234838

6	DRIVE MOTOR ASY,Y AXIS	1	1234773
7	SHAFT,Y AXIS	1	1234927

CATCHER COMPONENTS

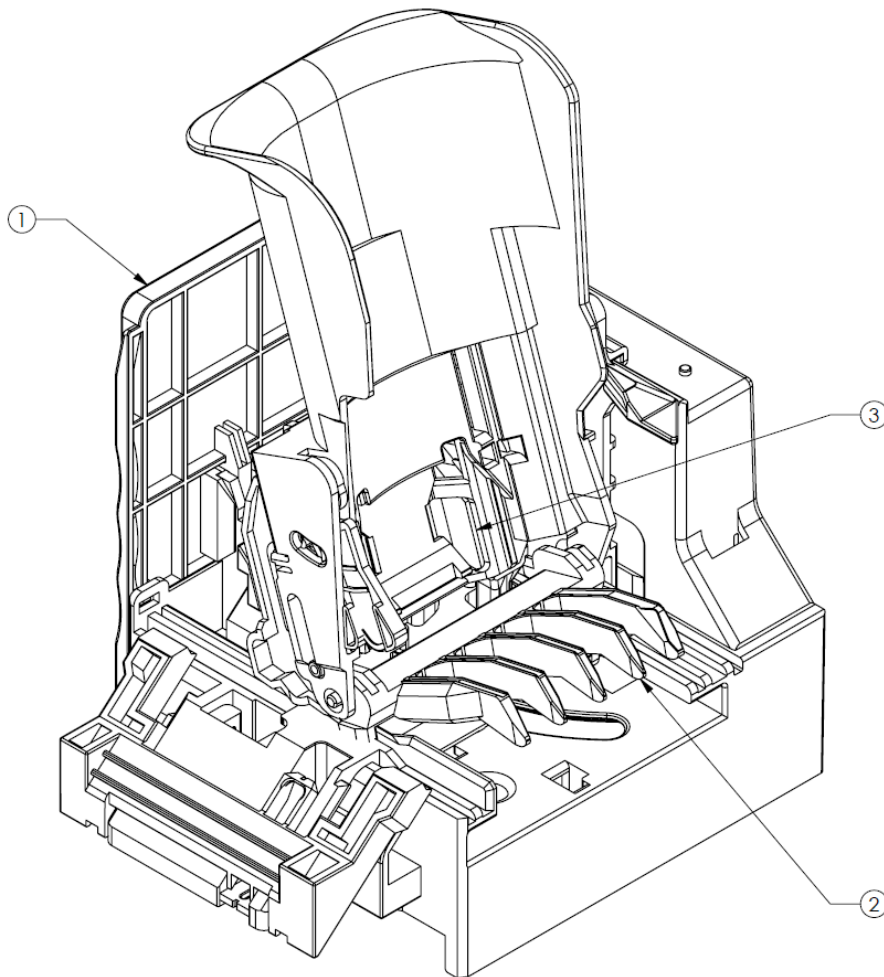

ITEM NO	DESCRIPTION	QTY	PART NO
	Product Delivery Catcher Assembly	1	1222442
1	DECAL HOLDER, CATCHER ASSY (38132-40160)	1	1259148
2	FORK, CATCHER ASSY (38132-40031)	1	1259156
3	DEL. ASSISTANCE,CATCHER ASSY (38132-40060)	1	1259164



CABINET SECTION

DOOR OPEN

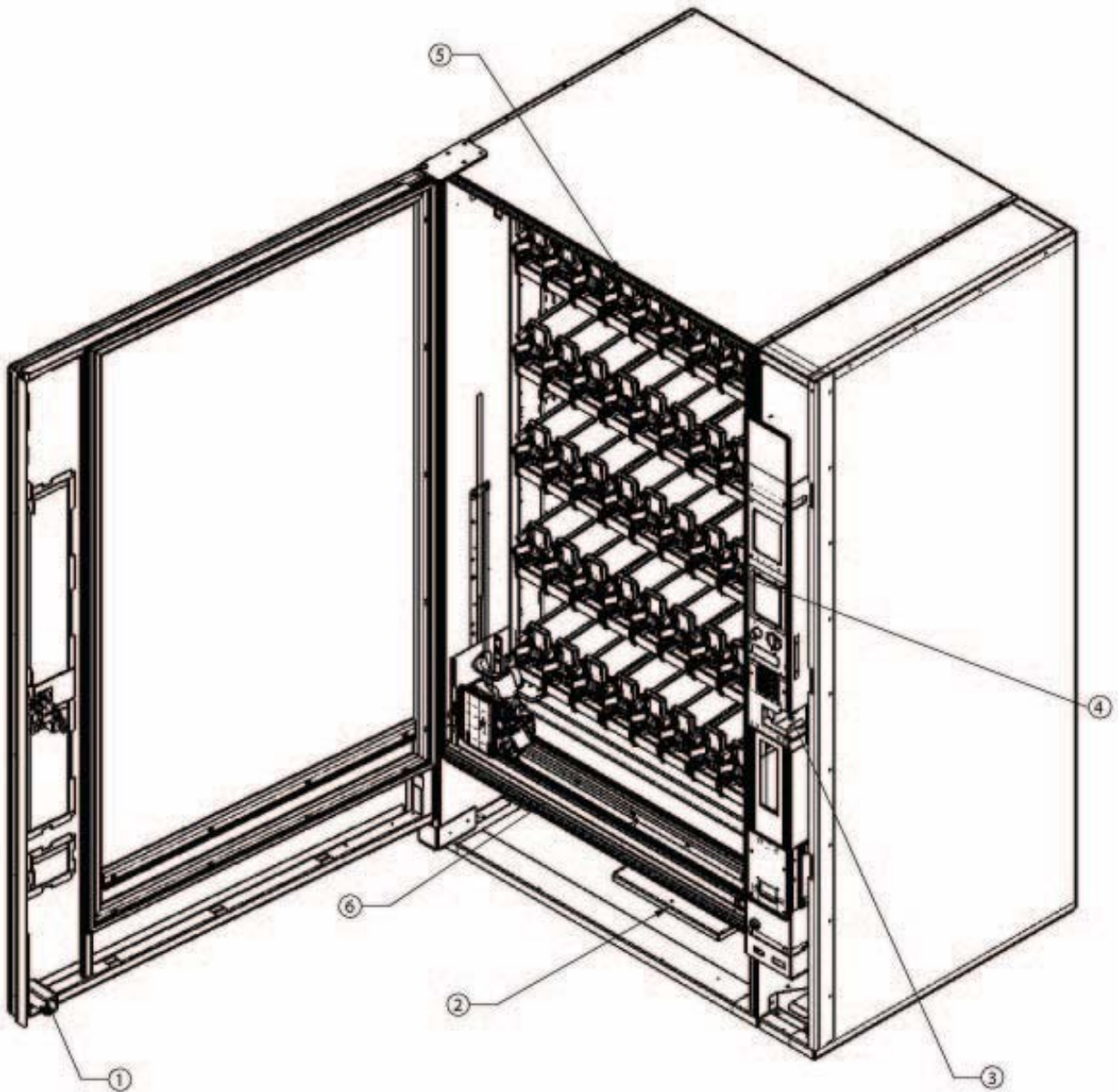

ITEM NO	DESCRIPTION	QTY	PART NO
1	DOOR ROLLER	1	1215662
2	REFRIGERATION UNIT	1	SEE PAGE D-5
3	CONTROL PANEL, DRAWER	1	1243446
4	SHELF ASSY	5	1221605
5	LED LIGHTING (LENS NOT INCLUDED)	1	1227476
6	ASY,LOWER KICK PANEL	1	1215887

AIR DUCT

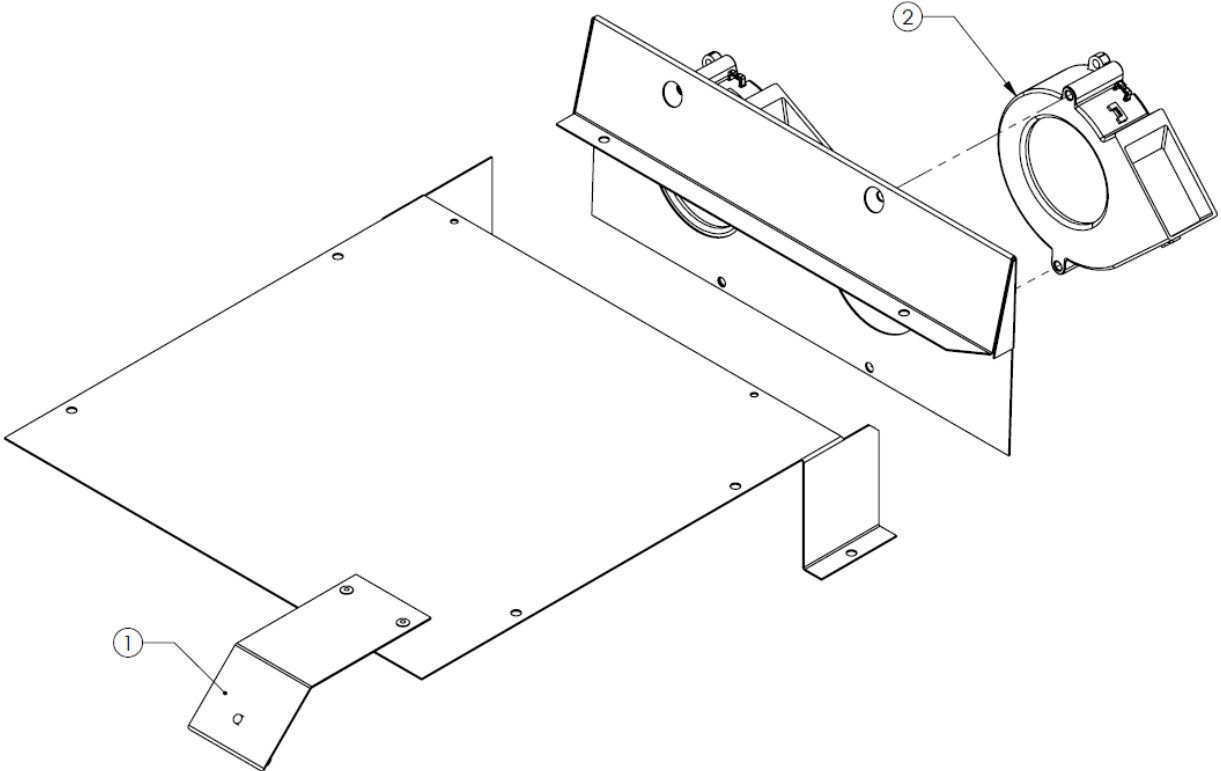

ITEM NO	DESCRIPTION	QTY	PART NO
	ASY,AIR SHROUD	1	1244094
1	ASY,TEMP SENSOR	1	1124254
2	BLOWER FAN	2	1242938

REFRIGERATION UNIT

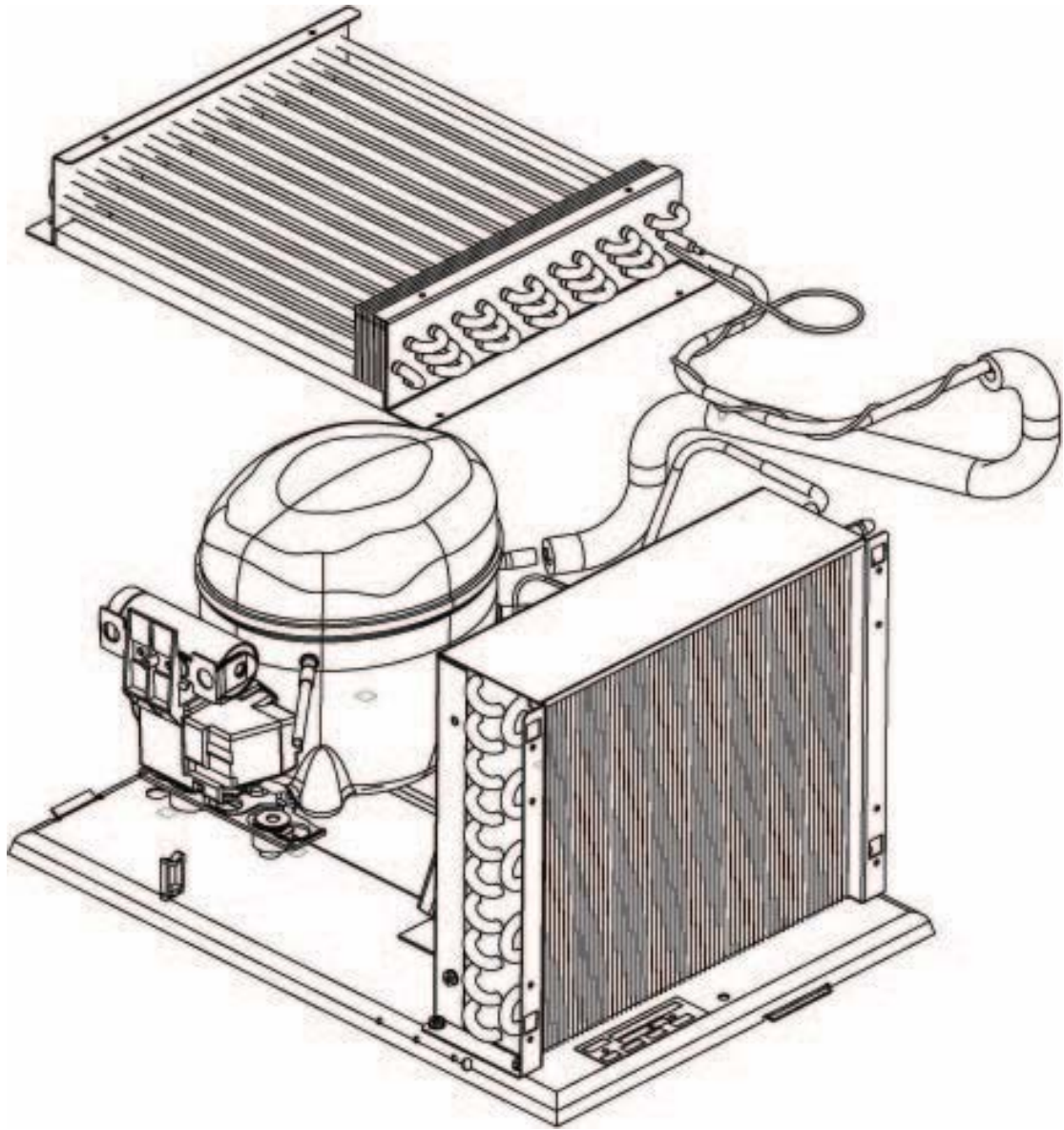

Drawing Reference Only

ITEM NO	DESCRIPTION	QTY	PART NO
1	RFG, 115v / 60 Hz – R134-a	1	1227583
2	RFG, 115v / 60 Hz – CO2	1	1244647
3	RFG, 115v / 60 Hz – R290	1	1258044



TRAY PARTS SECTION



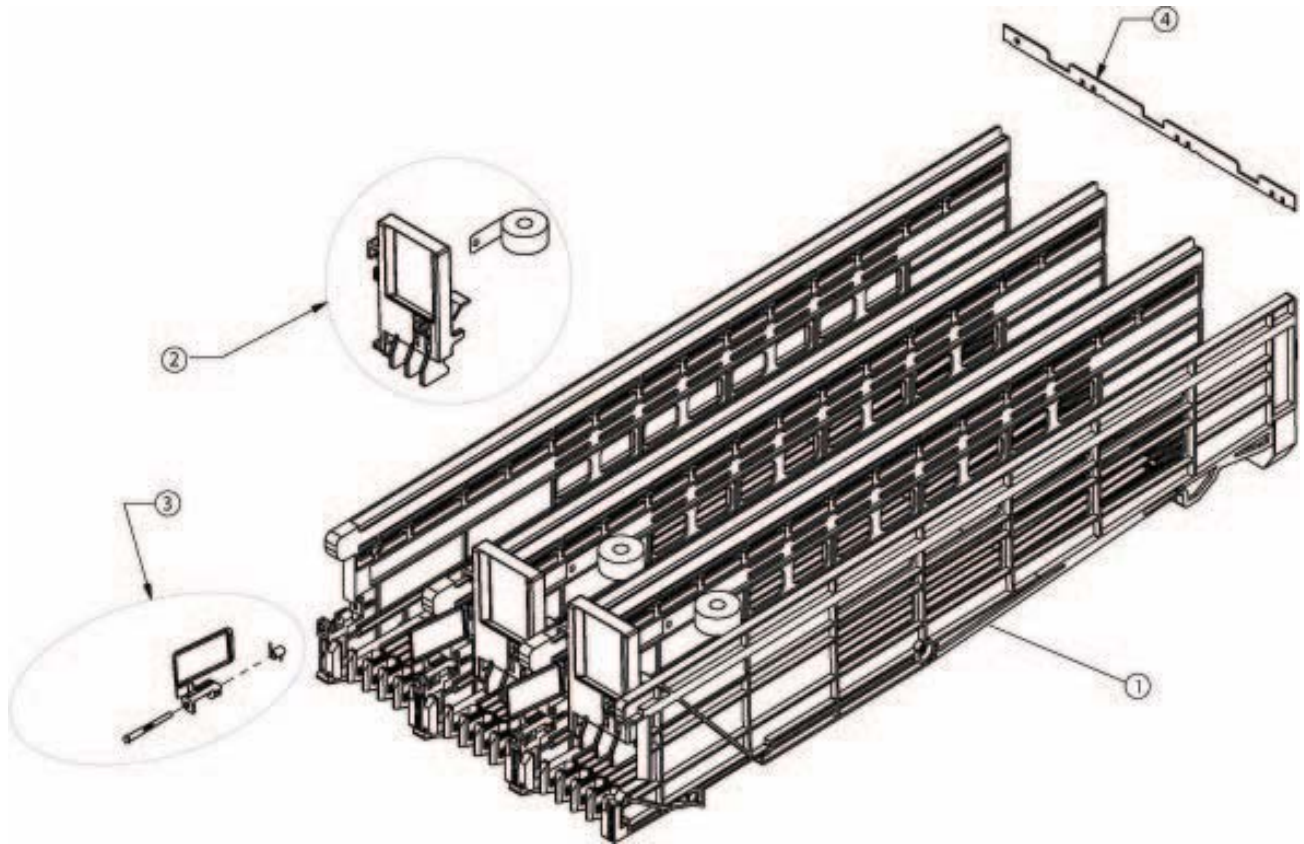



TRAY COMPONENTS



ITEM NO	DESCRIPTION	QTY	PART NO
1	COMPLETE TRAY ASSEMBLY	1	1221409
2	KIT,PRODUCT PUSHER (SET OF 6)	1	1243705
3	KIT,PRODUCT GATE (SET OF 6)	1	1243683
4	STIFFENER,TRAY COLUMN	1	1259172

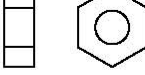
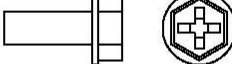

HARDWARE REFERENCE

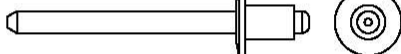
	PART NO.	DESCRIPTION	PICTORIAL
A	V802235	NUT,NYLOCK,THIN,6MM	
B	V800956	NUT 8-32 HEX	
C	V800952	NUT 10-32 HEX	
D	V801422	#10 X 1/2" TAPPING SCREW	
E	V801421	#10 X 1/2" TAPPING SCREW	
F	V801382	4-40 1/2" T CR PAN H	
G	V802214	8-10 X 1/2" CR PN THRD CUT	
H	V350359	RVT 3/16 STL.POP.126-.250	



HARNES REFERENCE

LOCATION	DESCRIPTION	QTY	PART NO
DRAWER	HIGH VOLTAGE-PWR SPLY	1	1223673
DRAWER	DMC TO RELAY BD	1	1223735
DRAWER	VMC TO MDB	1	1223744
DRAWER	MAIN DRAWER ASY	1	1223753
DRAWER	RELAY/CTRL BD TO PLT	1	1223806
DRAWER	DMC TO BACK PLT	1	1223815
CABINET	GFCI, CORD,POWER,GFCI,16GA	1	1225355
CABINET	X/Y MOTOR TO BCK PLT	1	1223708
CABINET	COMPRESSOR,HI VOLT	1	1223824
SIDE CAB	LIGHT-FAN-TEMP SNSR	1	1223682
SIDE CAB	GROUND CAB TO DRAWER	1	1230026
SIDE CAB	FLAP SWITCH	1	1223726



END OF LIFE / DISPOSAL

END OF LIFE / DISPOSAL

- To protect the environment please recycle materials where possible.
- Remove / reclaim refrigerant gas and compression oil in accordance with applicable laws and/or regulations.
Examples include US EPA 40CFR Part 82, Subpart F.
- Do not dispose the vending machine with other domestic waste. Vending Machines contain electrical and electronic materials that may need to be processed in accordance with local laws and/or regulations. Examples include European Directive WEEE 2002/96/CE
- Recycling this product contributes towards reducing the need for new materials and reducing the accumulation of waste.