

! Read these instructions. ! Failure to follow maintenance guidelines may result in a cancellation of warranty

Reach In Stainless with Steel Exterior and Glass Door



SILVER KING REFRIGERATION, INC.

1600 Xenium Lane N. Plymouth, MN 55441, USA

Telephone : (800)328-3329

Fax : (763)553-1209

Email : info@silverking.com

Website : www.silverking.com

**SKRU27-EGUS2 - RH DOOR
SKRU27-EGUS3 - LH DOOR**

46090 REV B 12/2019

- Before this appliance is used, it must be properly installed and located in accordance with the installation instructions.
- Do not allow children to climb, stand or hang on the shelves in the refrigerator or doors. They could damage the refrigerator and seriously injure themselves.
- Do not touch the cold surfaces in the refrigerator compartment when hands are wet. Skin may stick to these extremely cold surfaces.
- Do not store or use gasoline or other flammable vapors and liquids in the vicinity of this or any other appliance.
- Do not store pharmaceutical products, scientific materials or other temperature sensitive products in this appliance.
- Do not spray any flammable gas near the refrigerator.
- Keep fingers out of the "pinch point" areas; clearances between the doors and between the doors and cabinet are necessarily small; be careful closing doors when children are in the area.

► Safety Precautions

- Basic safety precautions must be followed when using electrical appliances as the followings.
- SILVER KING strongly recommends that any servicing must be performed by a qualified technician.
- Before this appliance is used, it must be properly installed and located in accordance with the installation instructions.
 - Do not allow children to climb, stand or hang on the shelves in the refrigerator or doors. They could damage the refrigerator and seriously injure themselves.
 - Do not touch the cold surfaces in the refrigerator compartment when hands are wet. Skin may stick to these extremely cold surfaces.
 - Do not store or use gasoline or other flammable vapors and liquids in the vicinity of this or any other appliance.
 - Do not spray any flammable gas near the refrigerator.
 - Keep fingers out of the "pinch point" areas; clearances between the doors and between the doors and cabinet are necessarily small; be careful closing doors when children are in the area.

1. Warnings & Safety Precautions



Notice to Customer

To avoid any risk of personal injury, material damage or incorrect use of this appliance, be sure to observe the following warnings and safety precautions. (After reading these owner's instructions, keep them in a safe place for future reference.)

Any loss or spoilage of products, such as food, loss of sales, or consequential damages is not covered by warranty.

Use appliances only for its intended purpose as described in this manual.

Failure to comply with these requirements might result in personal injury and (or) property damage, and will void warranty.

Serial number : The serial number is located on the rating label which is on the left interior wall of the unit. Retain the unit's serial number for service purposes.

1.	Warnings & Safety Precautions	-----	1
2.	Installation	-----	3
3.	Operation Guide	-----	6
4.	Maintenance, Cleaning	-----	7
5.	Troubleshooting	-----	9

- Unplug the appliance before cleaning and making repairs.
- Use caution, the unit does remain powered when system controls are used to turn off unit.
- Unplug unit before replacing the interior light
- Do not plug several appliances into the same wall outlet.
- After unplugging the appliance, wait at least five minutes before re-plugging it into a wall outlet.
- Any deterioration in the insulation may cause fire.
- Do not allow children to touch or play with the control panel.
- Do not stand or lean on the base panel, pull-out parts, doors and any other parts of the unit.
- Do not place this equipment directly under direct heat or sunlight.
- This appliance must be grounded.
You must ground the appliance to prevent any power leakages or electric shocks caused by current leakage from the appliance. Never use gas pipes, telephone lines or other potential lightning rods as grounding.
- Unplug the appliance before cleaning and making repairs.

Cautions

Proper disposal of freezer and refrigerator.

Child entrapment and suffocation are not problems of the past. Junked or abandoned refrigerators are still dangerous. Even if they will sit for "just a few days." If you are getting rid of your old refrigerator, follow the instructions below to help prevent accidents.

Before throwing away your old Refrigerator or Freezer:

- Take off all of the doors.
- Leave the shelves in place so that children may not easily climb inside.
- Remove the electrical cord plug so it can't be operated.

Use of extension cords is NEVER allowed

SILVER KING will not warranty any refrigerator that has been connected to an extension cord and/or multi-receptacle adaptor.

Do not install this appliance at an improper location

The installation location should not be exposed to direct sunlight and not placed near any heat source, e.g. stove, oven, radiator, or etc.

Replacement of parts

- Component parts must be replaced with like components.
- Servicing shall be done by authorized service personnel, to minimize the risk of possible ignition due to incorrect parts or improper service.
- Lamps must be replaced by identical lamps only.
- If the supply cord is damaged, it must be replaced by a special cord or assembly available from the manufacturer or its service agent.

Refrigerant Disposal

Your old refrigerator may have a cooling system that uses "Ozone Depleting " chemicals. If you are throwing away your old refrigerator, make sure the refrigerant is removed for proper disposal by a qualified service technician. If you intentionally release any refrigerants you can be subject to fines and imprisonment under provisions of environmental regulations. Meet all local and Federal code provisions or requirements when disposing of any refrigerated appliance.

2. Installation

Before you start to install your SILVER KING unit, carefully inspect it for freight damage. If damage is discovered, immediately file a claim with the delivery freight carrier. SILVER KING is not responsible for damage incurred during shipment.

To ensure that your unit works properly from the first day, it must be installed properly. We highly recommend a trained refrigeration mechanic and electrician install your SILVER KING equipment. If the installation is not up to professional standards, the appliance warranty can be voided.

Tools Required.

- Wrench (included with casters), Figure 2
- Adjustable Wrench
- Screwdriver
- Leveler



Figure 2

Uncrating

The following procedure is recommended for uncrating the unit. Move your unit as close to the final location as possible before uncrating.

** Keys for door locks are in manual packet.

2) Check all Part accessories listed are included with the appliance :

Models	Caster Box		Shelf Clip		Shelf	
	Quantity of casters		Quantity of clips		Quantity of Shelves	
SKBR1G-HC	R834E-130	4	R8429-060	1set(16ea)	R836A-070	1set(4ea)
SKBR2G-HC	R834E-130	4	R8429-080	1set(32ea)	R836A-050	1set(8ea)

1) Remove the wooden pallet :

Unscrew the bolts shown in Figure 1 (4-M13 Bolts)

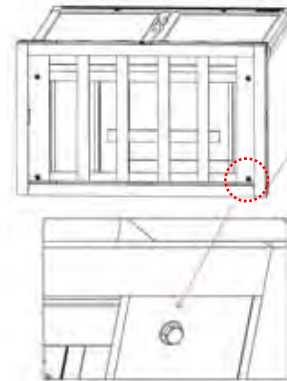

Figure 1

3) Assembling casters:

(1). Reach-ins (Figure3): Install casters in the bottom rails assembly on the bottom of the unit. It is important in order to achieve maximum strength and stability of the unit that you ensure that each caster is securely tightened with a 3/4" (19mm) open-ended wrench. Casters with brakes must be installed in front. And the casters must be in contact firmly with the bottom rails of the unit.

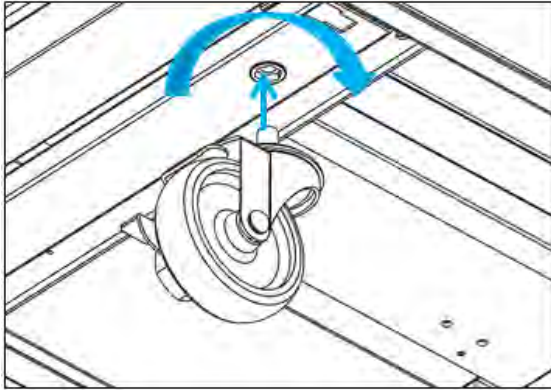

Figure 3

4) Leveling:

Proper leveling of your SILVER KING unit is critical to operating success. Effective condensate removal and door operation will be effected by leveling.

1) Reach Ins; The unit should be leveled front to back and side to side with a level. For unit with casters Models: Four shims have been provided in the caster package for leveling unit with casters units positioned on uneven floors. Shims must be positioned between rail end and bearing race.

- If the cabinet is not level, use a 3/4" (19mm) open-end wrench to turn the anchoring bolt under the bearing race counter-clockwise until the cabinet is level.
- Install the desired number of shims, making sure the slot of the shim is in contact with the threaded stem of the caster.
- If more than one shim is used, turn the slot at a 45° angle at least so they are not in line.
- Turn the anchoring bolt clockwise with a 3/4" (19mm) open-end wrench to tighten and secure the caster
- Ensure that the drain hose or hoses are positioned in the condensate water pan.
- Untangle plug and cord from unit (do not plug unit into power supply while leveling).
- The unit should be placed close enough to the electrical supply so that the extension cords are never used.

Warning: Warning Compressor warranties are void if the unit is more than 6-1/2 ft. (2m) from its receptacle. The outlet used for this connection must be relocated if it exceeds this length - 6-1/2 ft. (2m)

Caution

To avoid damage to lower rail assembly, raise unit slowly and carefully to upright position. If the unit was turned on its back or angled back more than 30°- the unit must be left in an upright position for at least 24 hours to allow the oil in the refrigerant to become re-equilibrated before the unit is plugged in or turned on.

Failure to do this voids its warranty and may damage the compressor or refrigeration system.

5) Ventilation:

Set unit in its final location. Be sure there is adequate ventilation in your room. you may need to install an exhaust fan under the extreme heat conditions, (90°F+, 32°C+),

Warning: Warranty is void if ventilation is insufficient.

6) Space clearance:

Ensure air circulation around unit

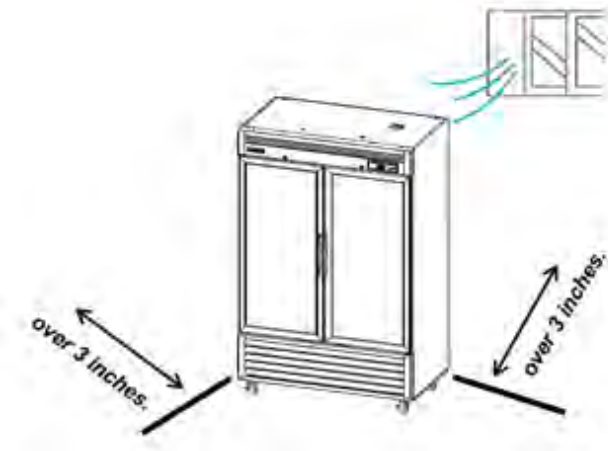

7) Assemble shelf clips :

- Install all the shelf clips before installing the shelves.
 - 1) Put the tap back side of clip into the hole of the pilaster.
 - 2) Rotate the clip with 180 degree.

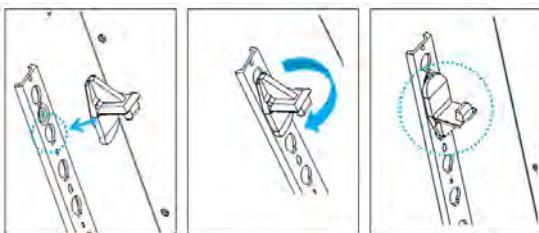

- Install the clips as shown above then install shelves.

7) To connect electricity :

The power cord of this appliance is equipped with a grounding plug which mates with a standard grounding wall outlet to minimize the possibility of electric shock hazard from the appliance.

Do not, under any circumstances, cut or remove the ground prong from the power cord.

For personal safety, this appliance must be properly grounded.

Have the wall outlet and circuit checked by a qualified electrician to make sure the outlet is properly grounded. If the outlet is a 2-prong outlet, it is your personal responsibility and obligation to have it replaced with the properly grounded wall outlet before using the unit.

A 3-prong outlet ensures the best performance and also prevents overloading building wiring circuits which could cause a fire hazard from overheated wires. Never unplug your refrigerator by pulling on the power cord.

Always grip plug firmly and pull straight out from the outlet.

Repair or replace immediately all power cords that have become frayed or otherwise damaged. Do not use a cord that shows cracks or abrasion damage along its length or at either end. Get it replaced immediately with a new cord installed by a licensed electrician.

A Nema 5-25 or 5-20 receptacle is required for this appliance.

- 1) NEMA Plugs
NEMA-5-15R, 115V/60/1

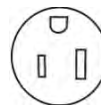

- 2) Make sure the power cord is connected to the proper voltage. (Rated ±10%)
- 3) Compressor warranties are void if compressor burns out due to usage of improper voltage.
- 4) A protected circuit of the correct voltage and amperage must be used. (15 or 20 amps)
- 5) Turn 'off the power switch before disconnecting the power cord whenever performing maintenance service or cleaning the refrigerated cabinet.
- 6) If the power cord of Refrigerator (Freezer) is damaged, it should be replaced by the manufacturer or service agent or a similarly qualified person in order to avoid a hazard.
- 7) If unit is disconnected, wait 5 minutes before re-starting.

“If you have any questions about set up or installation of your refrigerator, call technical services group for assistance”

8) Electrical requirements

“There are several factors that will affect the proper operation of your refrigerator. Among these factors, the electrical installation is the most important and should always be checked before connecting your refrigerator as follows: “

- 1) Make sure the electrical installation complies with national, state, and local codes.
- 2) Make sure the circuit is properly grounded.
- 3) Check circuit for proper voltage at receptacle.
- 4) Make sure that the wire gauge and breaker sizes are correct and comply with the minimum allowance for voltage drops (rated $\pm 10\%$)

☞ Default set temperature

- ▶ Refrigerator(Cooler) : 35°F(2°C)

3. Operation Guide

1) Temperature control range of appliances:

MODEL	Temperature
SKBR1G-HC	Hold 28° F ~ 39° F (-2.2°C ~ 3.9°C)
SKBR2G-HC	Hold 28° F ~ 39° F (-2.2°C ~ 3.9°C)

2) Operations

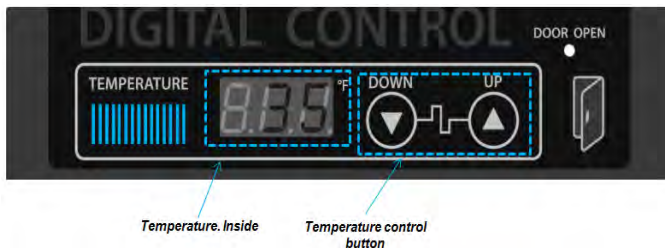

- Connect the power to the unit, the display panel will light up, and the compressor will begin to run.
- The compressor is automatically cycled by the electronic controller.
- The interior light is activated by the door switch when the door is open.
- Evaporator fan motors will run after all doors are completely closed.
- By pushing the UP/DOWN button, you can set the cabinet temperature.
- If door is opened, door opening indicator will be turned on.

4. Maintenance, Clean

For keeping the best efficiency, it is very important to clean the condenser coil in period. SILVER KING recommend to clean the condenser coil by a month. Dirty condensers result in compressor failure, product loss, and lost sales, which are not covered by warranty. If you keep the Condenser clean you will minimize your service expense and lower your electrical costs. The Condenser requires scheduled cleaning every month or as needed. Air is pulled through the Condenser continuously, along with dust, lint, grease, etc.

A dirty Condenser can result in NON-WARRANTEED part & Compressor Failures, Product Loss, and Lost Sales.

Proper cleaning involves removing dust from the Condenser. By using a soft brush, or vacuuming the Condenser with a shop vac, or using CO₂, nitrogen, or pressurized air.

If you cannot remove the dirt adequately, please call your refrigeration service company.

Tools Required:

- Screwdriver and Vacuum cleaner
- N2 or CO2 Tank
- Stiff bristle Brush (Not a wire brush but one with synthetic plastic bristles to prevent fin damage.)

- Reinstall the base and grille in the reverse order of disassembly. Make Tighten all screws.
- Plug the unit to power and check if compressor and fan is working.

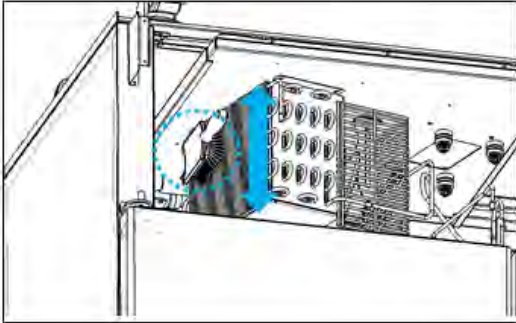

- Unscrew the base of the compressor and pull it out carefully until you have enough space to clean condenser coil. Do not make bend or pinch tubes and wires.
- Clean off accumulated dirt from condensing coil and fan blades with a stiff bristle brush.

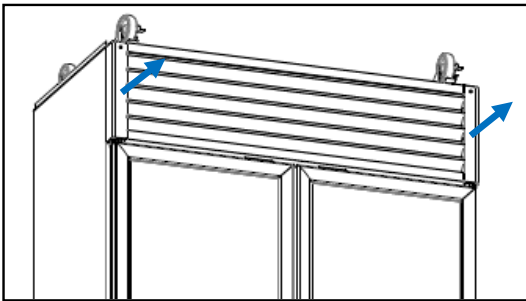

- Disconnect power to unit
- Take off grille at the bottom front by removing screws.

1) Cleaning the condenser coil

2) Cleaning the cabinet.

 To reduce the risk of electric shock, unplug before cleaning or service"

- A. Cleaning the interior and exterior
 - The interior and exterior of the unit can be cleaned using warm water with soap.
 - Do not use an abrasive cleaner because it will scratch the surface.
- B. Cleaning the gasket
 - The door gasket should be cleaned frequently to maintain proper sealing.
 - Use warm water and a mild soap.
- C. Cleaning the evaporator
 - If you need to clean the evaporator, please contact the qualified service technicians.
- D. Check after cleaning
 - Check the unit again for safety.
 - Check if the unit is operating properly.

Tips that help prevent rusting on stainless steel

- Use soft cloths or plastic scouring pads the will not harm the stainless steel's passive layer.
- Use the correct cleaning tools.
When cleaning your stainless steel products that make sure to use non-abrasive.
- Cleaning along stainless steel finish line.
Always scrub parallel to visible lines on stainless steels. Use a plastic scouring pad or soft cloth when you cannot see the grain.
- Use the cleaners that are either Alkaline, Alkaline chlorinated or Non Chloride based.
Avoid cleaners containing quaternary salts as they can attack stainless steel, causing pitting and rusting.
- Water Treatment.
It is recommended to use soft water when possible to reduce deposits. Installation of certain filters can remove corrosive and distasteful minerals.
Talk to a water treatment specialist if you are not sure of the proper water treatment.
- Clean your equipment frequently.

5. Troubleshooting

Problem	Possible Cause	Action
Compressor will not start	Power connection failure	Check Power Cord and plug it in
	Power switch is in off position	Ensure switch is in the "on" position
The unit does not refrigerate well	Temperature set point is too high	Correct temperature set point
	The door is opened too frequently	Minimize door opening
	Loading of too much warm or moist product	Load product in intervals
	Not enough ventilation	Move the unit to a well Ventilated location with at least 3 Inches of clearance on all sides
	Condenser is clogged	Clean it
Condensation On cabinet exterior	High moisture air can produce dews during the rainy season	Wipe with cloth

**** A water-flowing sound can be heard when the unit is operating. This is the sound of refrigerant flowing.**

SILVER KING

1600 Xenium Lane N. Plymouth, MN 55441, USA

Telephone : (800)328-3329



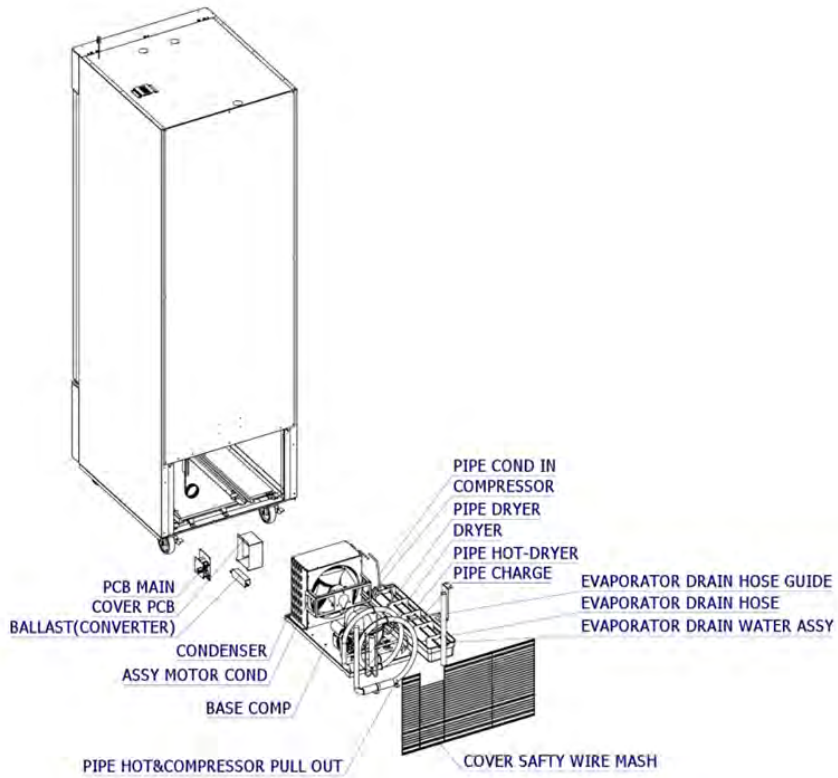
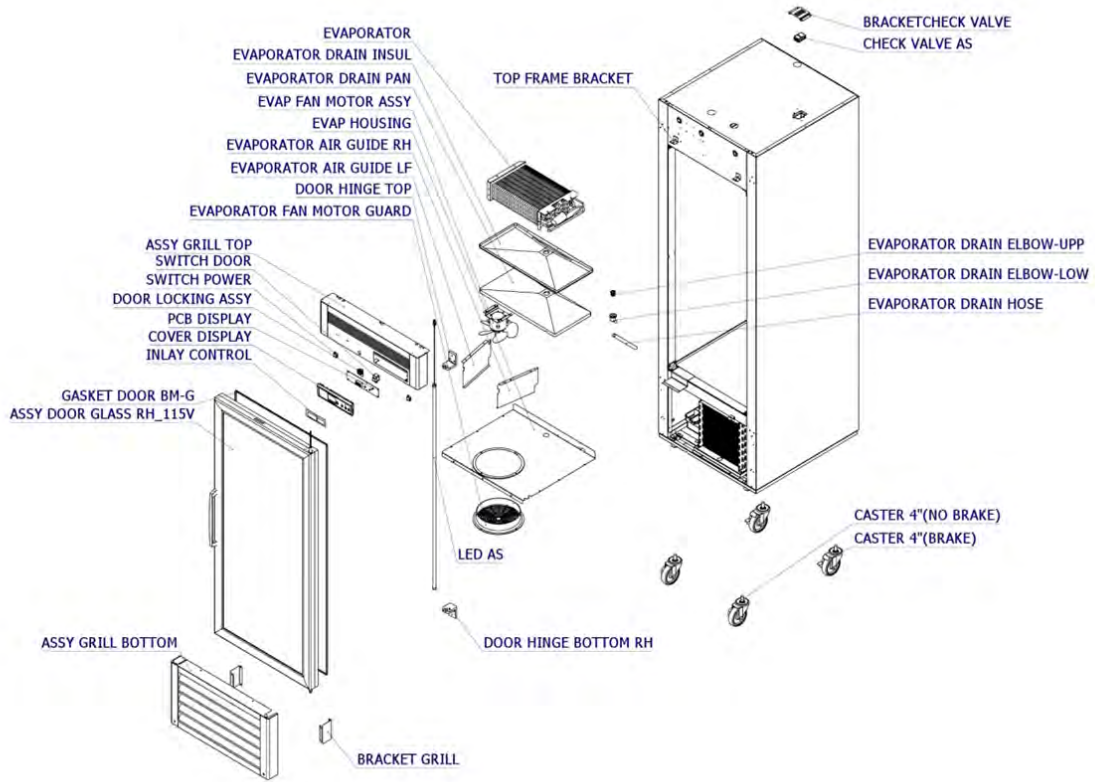

Fax : (763)553-1209

Email : info@silverking.com





Website : www.silverking.com





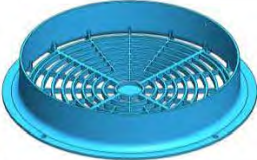
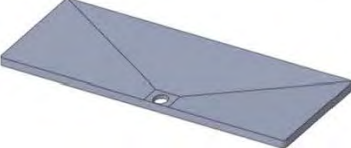
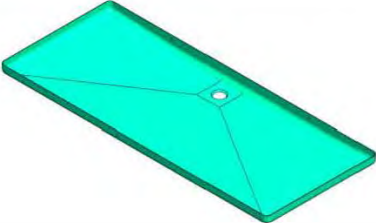





REPLACEMENT PARTS LIST





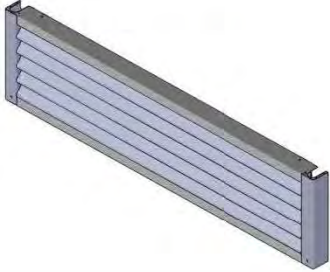

No.	SK Part No.	Part Name	Photo
1	43903	ASSY DOOR GLASS LH 115V	
2	43904	ASSY DOOR GLASS RH 115V	
3	44596	GASKET DOOR BM	
4	44090	DOOR HINGE TOP	
5	39763	DOOR HINGE BOTTOM RH	
6	44088	DOOR HINGE BOTTOM LF	
7	46052	POWER CORD 125V 15A/UL	

8	46053	CONDENSER	
9	46054	BRACKET COND MOTOR (R290 FE-COND)	
10	45804	CONDENSER FAN MOTOR BLADE	
11	46055	CONDENSER FAN MOTOR 115V60HZ DAI-8204DYCA CW	
12	46056	EVAPORATOR (R290 BM 23R/23RG)	
13	34366	EVAPORATOR FAN MOTOR BRACKET	
14	34365	EVAP FAN BLADE (8 INCH. CCW)	

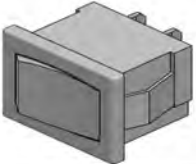
15	45811	EVAPORATOR FAN MOTOR 115V 60HZ DAI-8204DYCA-1 CCW	
16	45797	EVAPORATOR FAN MOTOR GUARD HIPS (VH-1800EX) .WHITE	
17	46057	EVAPORATOR DRAIN INSUL-S (23)T17*256*530, FOAM-PS	
18	46058	EVAPORATOR DRAIN PAN- SMALL ALUM+COATING	
19	46059	EVAPORATOR DRAIN ELBOW- UPPER	
20	46060	EVAPORATOR DRAIN ELBOW- LOWER	
21	46061	EVAPORATOR DRAIN HOSE-A	
	46062	EVAPORATOR DRAIN HOSE-C	

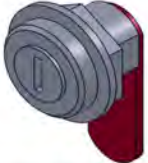
22	46063	EVAPORATOR DRAIN HOSE GUIDE	
23	35076	EVAPORATOR DRAIN WATER-S ASSY MSF/R-23NM	
24	34348	EVAPORATOR DRAIN WATER SMALL ABS,BLK(3021 1L0700)	
25	34350	EVAPORATOR WICKING GUIDE	
26	34352	EVAP WICKING	
27	34351	EVAP WICKING GUIDE	
28	46064	LED AS 110V-220V	
29	34343	DRYER	

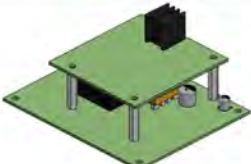
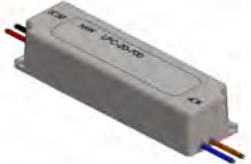
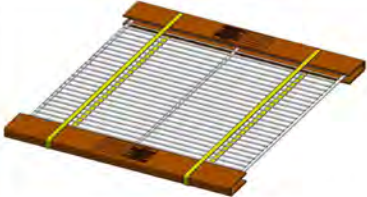
30	46065	PIPE HOT&COMPRESSOR PULL OUT AS R290 BM 23R/23RG	
31	46066	REINFORCEMENT HINGE LF/RH	
32	44405	ASSY GRILL BOTTOM BM23RG	
33	46067	ASSY GRILLE TOP SKBR1G-HC	
34	46068	DISPLAY AS	
35	46069	CONTROL BOARD (DIGITAL DISPLAY)	
36	46070	PCB DISPLAY 88 DP1(R290 REACH IN)	
37	46071	INLAY CONTROL (EXPERT)	
			

38	46072	SWITCH POWER	
39	46073	SWITCH DOOR R290 REACH IN	
40	45815	DOOR LOCKING ASSY	
41	46074	CHECK VALVE AS	
42	46075	PCB MAIN(R290 BLUE AIR) (REF) BM 115V	
43	46076	BALLAST (CONVERTER) 115V DC 30V E320521 LPC-20-700	
44	46077	SHELF PACK J-23G 4EA WRAP 551*580	
45	46078	SHELF CLIP 16 SET	

46	46079	SHELF STANDARD L T1.2*930mm	
47	46080	SHELF REAR B SWRM+PE/C 350*790	
48	46081	SHELF REAR CLIP POM 11*24.1*H30	
49	36354	GRAVITY SLIDE	
50	46082	ASSY PACKING CASTER BOX 23/49 4" Caster 2EA + Caster with Brake 2EA Washer	
51	46083	D-SENSOR WHITE, L=180MM	
52	46084	ASSY HARNESS INNER (R290 BM 23RG)	N/A
53	46085	HARNESS CONNECT 5P(R290 BM)	N/A
54	46086	HARNESS SWITCH (R290 BM 23R/F/RG)	N/A
55	46087	HARNESS COMP (R290 REF/23F)	N/A
56	46088	HARNESS EARTH-A	N/A
57	46089	HARNESS SENSOR H	N/A

CIRCUIT DIAGRAM

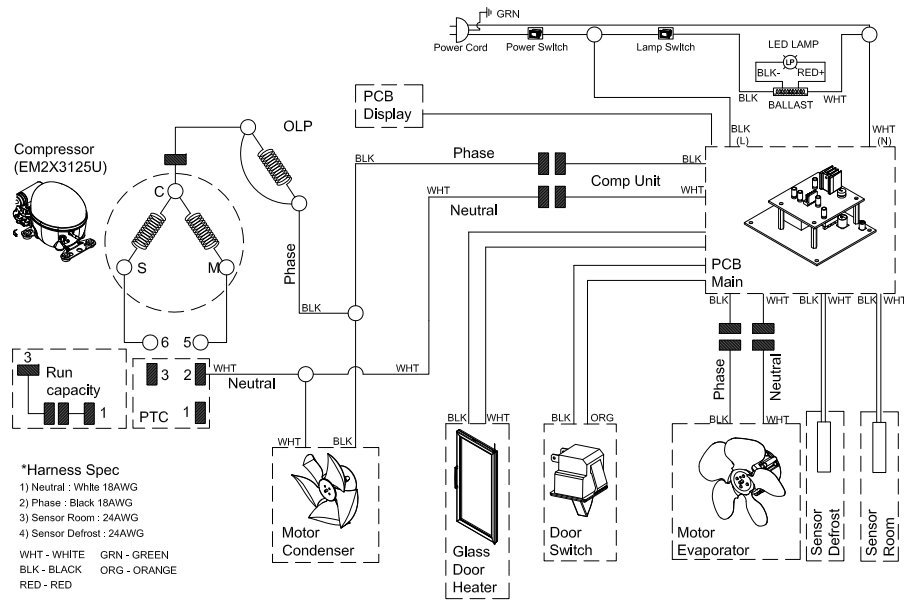

***Harness Spec**
 1) Neutral : White 18AWG
 2) Phase : Black 18AWG
 3) Sensor Room : 24AWG
 4) Sensor Defrost : 24AWG
 WHT - WHITE GRN - GREEN
 BLK - BLACK ORG - ORANGE
 RED - RED

(115V/60Hz)

* 23RG-HC

PCB LAYOUT

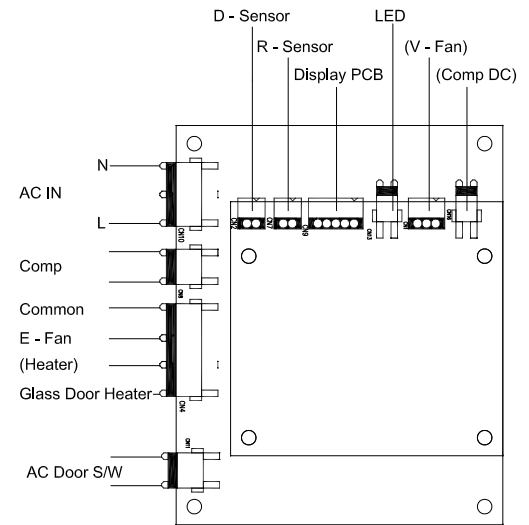

R510E-040

TERMS AND CONDITIONS

LIMITED WARRANTY

Silver King warrants to the original purchaser of Silver King refrigerated Equipment (as defined below), that the Equipment shall be free from defects in material and workmanship under normal use and service as outlined in the Technical Manual. This limited warranty shall apply for a period of time not to exceed the earlier of the following: one (1) year from the date of original purchase of the Equipment or 18 months from date of production of the Equipment. Equipment includes General Market Refrigeration units and excludes all Dispensing and Custom Holding Refrigeration or extended agreements whose written terms are conditional at time of sale or contract. All warranties are subject to specific limitations outlined below.

This limited Equipment warranty does not apply to:

- Repair or replacement required as a result of carelessness or neglect.
- Improper installation, incorrect voltage supply, modifying, tampering with or altering components and/or Equipment.
- Failure to perform proper maintenance. Equipment damaged in transit, by fire, flood or an act of God is not covered.
- Unit is compromised by adding excess weight or adhering non-approved components to the frame.
- Combining the equipment with hardware, fixtures, accessories or other equipment not provided by Silver King.
- Misuse of the Equipment or use of the Equipment not in accordance with the Technical Manual.
- Warranty excludes consumables or replacement components such as shelving, trays, gaskets, etc.
- Warranty excludes interior liner or exterior shell.

The limited Equipment warranty does not include freight, handling, installation, labor (following the one (1) year labor warranty period) or other incidental or consequential costs including product and/or economic loss. This limited Equipment warranty is in lieu of all other warranties, express or implied, are hereby disclaimed and excluded including those of merchantability, and fitness for a particular purpose. This limited Equipment warranty is non-transferable. Specific provisions of this limited Equipment warranty are as follows:

90 DAY REPLACEMENT PARTS WARRANTY

Silver King warrants to the original Equipment purchaser that a replacement OEM part thereof will be free of defects in material and workmanship, under normal use and service, for a period of 90 days from the date of original purchase of such replacement OEM part subject to all terms and conditions herein.

Three (3) Year Drawer Slide Warranty

Silver King warrants to the original Equipment purchaser for a period of time not to exceed the earlier of the following: three (3) years from the date of original purchase of the Equipment or three (3) years and six (6) months from the date of shipment from the factory of the equipment, that it will replace the drawer slides with one of similar design and capacity, exclusive of delivery and installation charges, if it is found in Silver King's review to be inefficient or inoperative due to defects in material or factory workmanship.

FIVE (5) YEAR COMPRESSOR WARRANTY

Silver King warrants to the original Equipment purchaser for a period of time not to exceed the following: five (5) years from the date of original purchase of the Equipment or five (5) years and six (6) months from the date of shipment from the factory of the Equipment, that it will replace the compressor with one of similar design and capacity, exclusive of delivery and installation charges, if it is found subject to Silver King's review to be inefficient or inoperative due to defects in material or factory workmanship. It is the original purchaser's responsibility to return the serial plate of the defective compressor, or at Silver King's option the complete compressor, to the factory. Failure to do so will void this limited compressor warranty. This limited compressor warranty shall be limited to parts only after the LIMITED WARRANTY period applicable to the Equipment has expired.

This limited Equipment warranty is limited to repairing or replacing any parts that, at Silver King's discretion, are deemed to be defective within the time period covered by this warranty. The 90 day parts warranty covers standard

freight and handling charges. Special handling charges or expedited means for transport are excluded from reimbursement. Use of non-OEM parts may, at Silver King's discretion, void this warranty. If approved, warranty credit for non-OEM parts will be issued at the OEM cost. Replacement parts sold separately are warranted for 90-days from date of purchase.

ADDITIONAL WARRANTY GUIDELINES:

A factory issued Service Authorization Number must be obtained prior to work being performed under the one (1) year labor warranty. Contact your supplier or Silver King. Claims submitted without a Service Authorization Number will be paid at Silver King's discretion. The labor warranty includes standard straight time labor charges in accordance with Silver King's Labor Warranty Guidelines and reasonable travel time, as determined as determined in the Silver King time – rate guide.

Silver King, at its discretion, may request photos during or prior to service being dispatched to validate a technical issue. Failure to comply with the request may result in the cost of service being the responsibility of the service requestor or site.

The limited labor warranty does not cover original installation, startup, normal adjustments or maintenance. Normal adjustments and maintenance include, but are not limited to; temperature control adjustments, temperature indicator calibrations, coil and filter cleaning, or condensate drain cleaning.

A second service call for a related failure is not covered.

Use of refrigerants other than specified on the Equipment serial plate voids the warranty. All claims must include; model and serial number of equipment, date of purchase, date of failure, and a copy of the service invoice detailing the defect and service performed. No claim will be processed without this information. All claims must be filed within 30 days from date of service.

PRODUCT ORDERING INFORMATION

Call us toll free at 1-800-328-3329 or 1-763-923-2441 Fax us at 1-763-553-1209

Visit www.silverking.com for stocking distributor, equipment specs and current price list for your area.

SERVICE / PARTS ORDERING INFORMATION

Call us toll free at 1-800-328-3329, prompt 1 or 2

TERMS AND CONDITIONS

- This price list and conditions are effective January 1, 2019 and supersedes all previous pricelists.
- LIMITED WARRANTY period may vary from customer to customer and is contract specific.
- All prices reflect payment in U.S. Dollars.
- Prices do not include any freight, duty, or taxes.
- Pricing subject to change without notice.
- No returns are accepted without prior written approval from the factory. An RMA (Returned Merchandise Authorization) form must be completed and then approved by Silver King. Please contact Silver King for details. Restocking fee will apply.
- All electrical equipment is single phase.
- Prices, designs, and specifications are subject to change without notice.
- Payments via credit card are subject to a 3% surcharge.
Silver King
1600 Xenium Lane, Plymouth, MN 55441-3706
www.silverking.com • 1-800-328-3329

© Silver King 2019 Prices Subject To Change

