

# Technical Manual and Replacement Parts List

---

## Refrigerated Pizza Prep Table



MODEL: **SKPZ60-FSUS10**

1600 Xenium Lane North, Minneapolis, MN 55441-3787  
Phone (763) 923-2441

**SILVER KING**<sup>®</sup>

FORM NO. 45339 REV A 11/2019

Specifications Subject to Change Without Notice.



**TECHNICAL MANUAL**  
**SILVER KING PREPARATION TABLES**  
**MODEL SKPZ60-FSUS10**

Thank you for purchasing Silver King food service equipment. Our goal is to provide our customers with the most reliable equipment in the industry today. Please read this manual and the accompanying warranty information before operating your new Silver King unit.

**INSPECT FOR DAMAGE AND UNCRATE**

Upon delivery of your new Silver King unit, uncrate at once to inspect for possible freight damage following the instructions printed on the exterior of the container. Report any damages to the carrier responsible for transportation and promptly present a claim for any evidence of mishandling. Save all packaging materials if a claim is filed.

**PRECAUTIONS BEFORE USING THIS PRODUCT**

- This appliance is not intended for use by persons (including children) with reduced physical, sensory or mental capabilities, or lack of experience and knowledge, unless they have been given supervision or instruction concerning use of the appliance by a person responsible for their safety.
- Use caution when cleaning the condenser, the fins are very sharp.
- For units with a dual hertz rating, no adjustments are required for normal operation.
- If the supply cord is damaged, it must be replaced by the manufacturer, its service agent or similarly qualified persons in order to avoid a hazard.
- This refrigeration unit is not intended to be used at altitudes higher than 2000 meters.
- Do not store explosive substances such as aerosol cans with a flammable propellant in this appliance.
- Do not exceed the maximum load capacity of 50 pounds per shelf.
- Use caution when moving, installing, maintaining and using this refrigeration device to avoid either damaging the refrigerant tubing or increasing the risk of a leak.
- All component parts must be replaced with like components and all servicing must be done by factory authorized service personnel, so as to minimize the risk of possible ignition due to incorrect parts or improper service.
- If the unit has recently been transported on its side (or placed horizontally), then please let unit stand with the casters (or feet) on the ground for a minimum of 24 hours before plugging it in.



**WARNING:** This product can expose you to chemicals including lead, which are known to the State of California to cause cancer, birth defects, or other reproductive harm.

## **INSTALLATION**

The stainless steel exterior of the cabinet has been protected by a plastic covering during manufacturing and shipping. This covering can be readily stripped before installation. After removing this covering, wash the interior and exterior surfaces using a warm, mild soapy water solution and a sponge or cloth, rinse with clean water and dry.

### **Casters**

The unit comes with plate casters and mounting screws packed inside the unit. To install the casters, tip the unit on its back, and locate the 4-hole patterns in the base of the unit. Use the hex head screws provided to mount the plate casters. Align the plate caster over the 4-hole pattern and install the hex screws tightly. Return the unit to the upright position. **\*\*Allow at least two hours of off time before connecting to a power source.**

### **Pans and Pan Supports**

The Pans and Pan Supports are packaged with the unit.

### **Cutting Board**

The Cutting Boards are shipped with the cabinet. The Cutting Boards have two holes in them that align with studs installed on the top of the cabinet. To install the Cutting Boards place the back of the boards under the lip in front of the raised rail and set them down so the studs on the cabinet top align with the holes in the Cutting Boards. The Cutting Boards are reversible to extend wear.

### **Shelves**

Inside the unit you will find Shelves and a plastic bag containing Shelf Supports. The Shelf Supports hook into the Pilasters that are mounted in the cabinet. The Shelf Supports with the tang go on the rear Pilasters. This shelf system allows for easy adjustment to suit your needs.

### **Door Adjustment**

Should the Door ever require straightening, loosen the Screws on the Hinges, square the Door with the cabinet and retighten the Screws.

### **Location**

When locating your new refrigerator, convenience and accessibility are important considerations, but the following installation guidelines must be followed:

- Always avoid placing the refrigerator adjacent to an oven, heating element or hot air source that would affect the operation of the unit.
- For proper ventilation, the bottom front and rear of the unit must not be obstructed. The unit must be on legs or casters to raise it off the floor. The unit can be installed tight on the sides.
- The unit must be level or tilted backwards slightly.

### **Climate Class Rating**

Your Silver King Prep Table has a climate class 4 rating. It is designed for use in areas not exceeding 30°C (86°F).

## Electrical Connections

Be sure to check the data plate, located on the liner of the cabinet, for required voltage prior to connecting the unit to power. The specifications on the data plate supersede any future discussion.

The standard refrigerator is equipped with an eight (8) foot power cord that requires a 115 Volt, 60 Cycle, 1 Phase properly grounded electrical receptacle. The power cord comes with a 3 prong plug for grounding purposes. Any attempt to cut off the grounding spike or to connect to an ungrounded adapter plug will void the warranty, terminate the manufacturers responsibility and could result in serious injury.

The circuit must be protected with a 15 or 20 ampere fuse or breaker. The unit must be isolated on a circuit and not plugged into an extension cord.

## OPERATION

### Initial start up

After satisfying the installation requirements, the refrigerator is ready to start. The Compressor will start when the power cord is connected to the required power source. If the Compressor does not start when the unit is initially plugged in, check to make sure that the Temperature Control is not in the off position. Allow the unit to run for two hours before loading it with product. When loading the unit with product, take care not to block the air flow in the cabinet as this would affect the units performance.

### Temperature Control

The Temperature Control is located on the back of the cabinet and is factory set to maintain an average cabinet temperature of approximately 38 Deg F. To obtain colder temperatures, press and hold the set button until the set point value flashes. Use the up or down arrow buttons to change the value and then press the set button again. Allow the unit a minimum of one hour to respond to a control setting adjustment.

### Defrost

Your Silver King refrigerator is an automatic defrost unit and no additional plumbing is required. Automatic defrosting is accomplished when frost buildup on the Evaporator Coil is cleared during Compressor off cycles. Defrost water is collected in a pan located in the compressor compartment where it is evaporated into the room air. It is important that the unit be installed level to allow proper drainage of the defrost water.

## MAINTENANCE

Preventative maintenance is minimal although these few steps are very important to continued operation and maximizing the life of the appliance.

### Cabinet Surfaces

The cabinet interior is aluminum and the exterior is stainless steel. These surfaces should be cleaned periodically with a solution of warm water and mild soap, rinsed and wiped dry with a soft cloth. A good stainless steel cleaner can also be used. Should a surface become stained, do not attempt to clean with an abrasive cleanser or scouring pad. Use a soft cleanser and rub with the grain of the metal to avoid scratching the surface. Do not use chlorinated cleaners. Always rinse well and dry after cleaning.

### Condenser

Periodically, dust on the condenser coil must be cleaned. The condenser is located on the rear of the unit. Clean the accumulated dust/debris from the condenser with a vacuum or brush or chemical cleaning agent (Nu-Calgon 4171-75 or equivalent). This will need to be done regularly to maintain the compressor warranty!

**WARNING: The condenser fins are very sharp, use caution when cleaning the condenser.**

### Door Gasket

The Door Gasket will collect dirt and should be wiped clean with a warm, mild soapy water solution to extend its life and assure maximum cabinet performance and life.

MODEL \_\_\_\_\_ SERIAL NO. \_\_\_\_\_ DATE INSTALLED \_\_\_\_\_

## AIR CURTAIN INSTALLATION INSTRUCTIONS

APPLIES TO THESE MODELS: SKP278A, SKP2712A, SKPZ27(D), SKR27A(D), SKF27A(D),  
SKR48A, SKF48A, SKP4812A, SKP6024(D), SKPZ60(D), SKPZ72(D), SKPZ92(D)

**DO NOT OPERATE UNIT WITHOUT AIR CURTAIN INSTALLED**

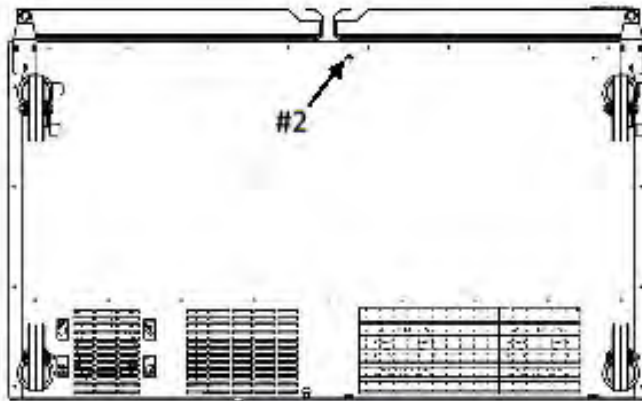

SKR48A SHOWN

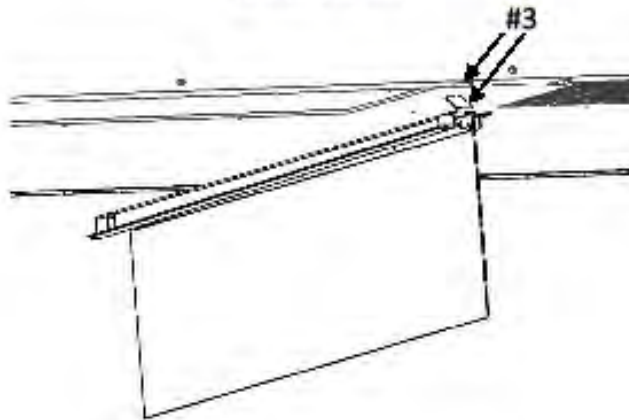

1. Disconnect unit from power source.
2. Tip the unit on its back and loosen the center screw along the front bottom edge of the base.
3. Insert the tab on the end of the air curtain into the slot located along the rear lower edge of the unit.
4. Slip the opposite end of the air curtain under the screw head loosened in step #2 and tighten screw to secure the air curtain to the base.
5. Return unit to original upright position.

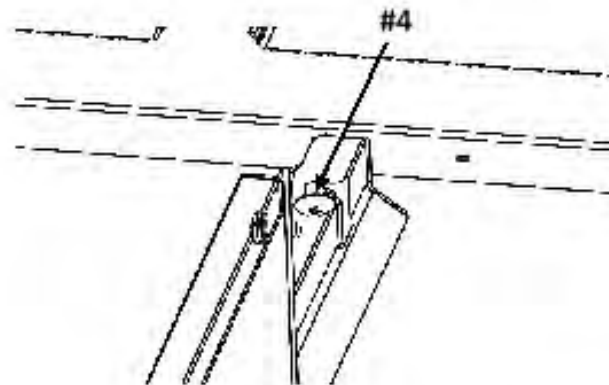

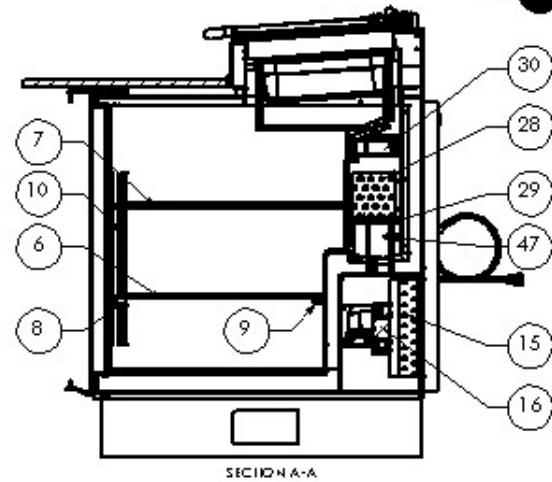
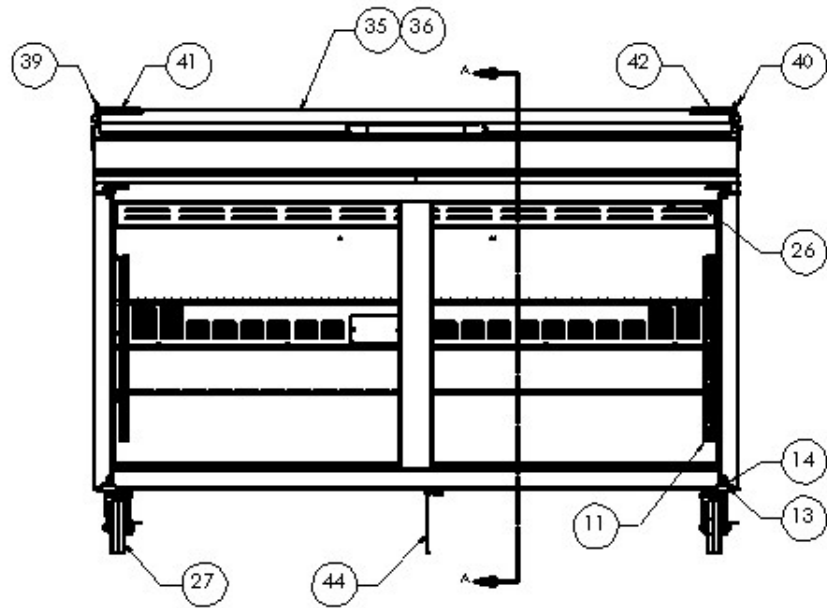
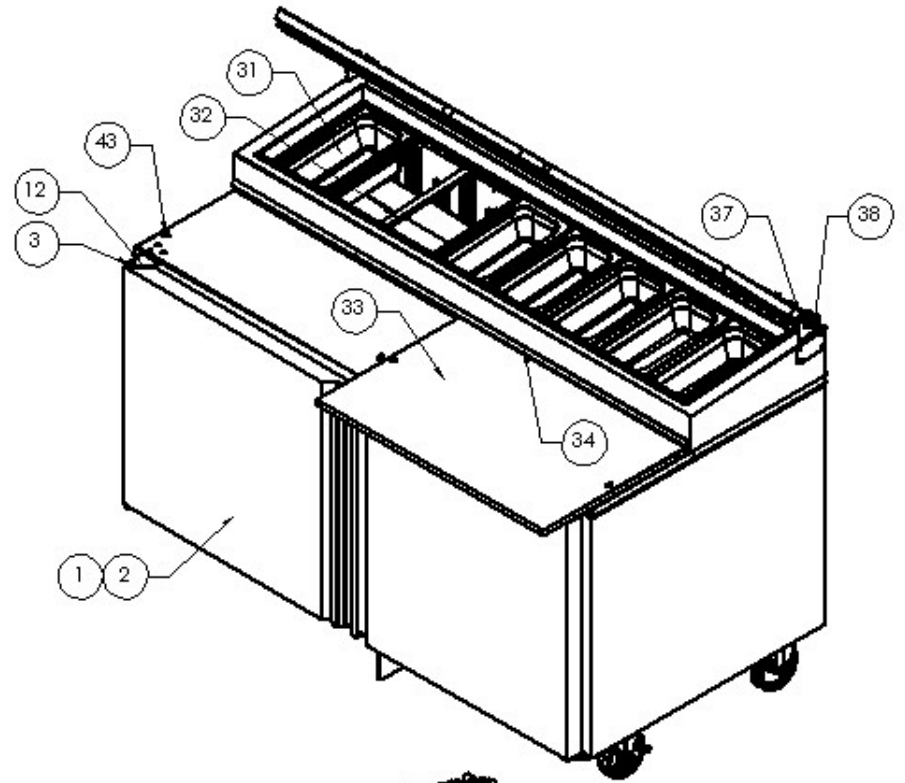
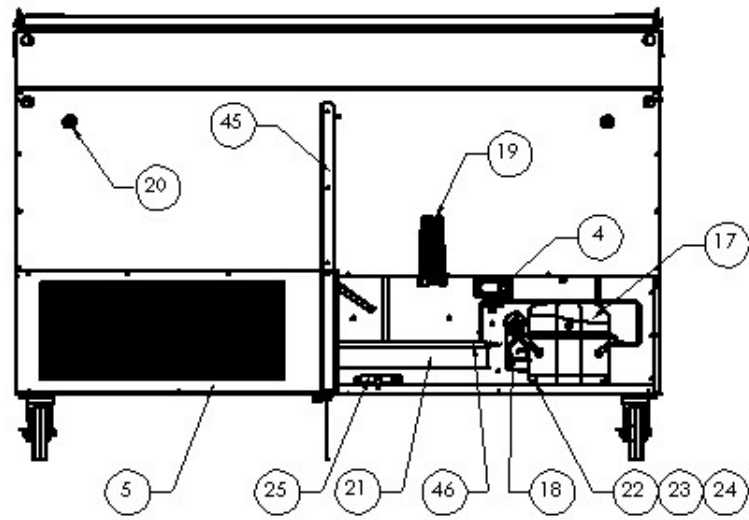

SECCION A-A

# REPLACEMENT PARTS LIST – SKPZ60-FSUS10

ITEM NO.	PART DESCRIPTION	PART NO.
1	DOOR ASSEMBLY	38472
2	KIT DOOR GASKET	10310-80
3	HINGE PIN	22415
4	ELECTRONIC CONTROL 115V (PROGRAMMED)	38285
5	BACK PANEL LH (CONDENSER)	38008
	BACK PANEL RH (COMPRESSOR)	38009
6	SHELF (LOWER)	23948
7	SHELF (UPPER)	23949
8	SHELF SUPPORT WITHOUT TANG	99530
9	SHELF SUPPORT WITH TANG	99531
10	SHELF PILASTER 16 IN	42986
11	SHELF PILASTER 8.5 IN	43515
12	HINGE (UPPER)	27181
13	HINGE (LOWER)	24549
14	DOOR BUSHING	99711
15	CONDENSER COIL	38010
16	FAN MOTOR CONDENSER 115V	37736
17	KIT COMPRESSOR 115V (WITH DRIER & ELECTRICALS)	10343-75
18	KIT ELECTRICALS COMPRESSOR 115V (OVERLOAD, RELAY, ETC)	10344-75
19	POWER CORD 115V	32199
20	BUMPER REAR	99574
21	CONDENSATE PAN ASSEMBLY W/ WICKING	38163
22	GROMMET COMPRESSOR MOUNT	20481
23	WASHER COMPRESSOR MOUNT	22401
24	HAIRPIN CLIP COMPRESSOR MOUNT	98106
25	DRIER	22677
26	TEMPERATURE INDICATOR	22409
27	KIT PLATE CASTERS 6 INCH	10314-75
28	EVAPORATOR COIL	37941
29	CAPILLARY TUBE	31236
30	FAN MOTOR EVAPORATOR 115V	37736
31	PAN PLASTIC 1/3 SIZE 4" DEEP	27066
32	PAN ADAPTER BAR	25567
33	KIT CUTTING BOARDS 19"D-3/4"T	10330-38
34	CUTTING BOARD REAR BRACKET	32827
35	COVER PANS	38729
36	GASKET COVER	38728
37	THREADED KNOB	24305
38	PIN PIVOT	23503
39	BRACKET COVER LH	31210
40	BRACKET COVER RH	31211
41	HINGE PLATE ASSEMBLY LH	36685
42	HINGE PLATE ASSEMBLY RH	36686
43	KNOB THREADED	24305
44	AIR CURTAIN	26498
45	AIR DIVIDER	38221
46	KIT REPLACEMENT WICKING	10327-93
47	TEMPERATURE PROBE	38822

FORM 45338

WHEN ORDERING REPLACEMENT PARTS, PLEASE PROVIDE MODEL AND SERIAL NUMBERS.

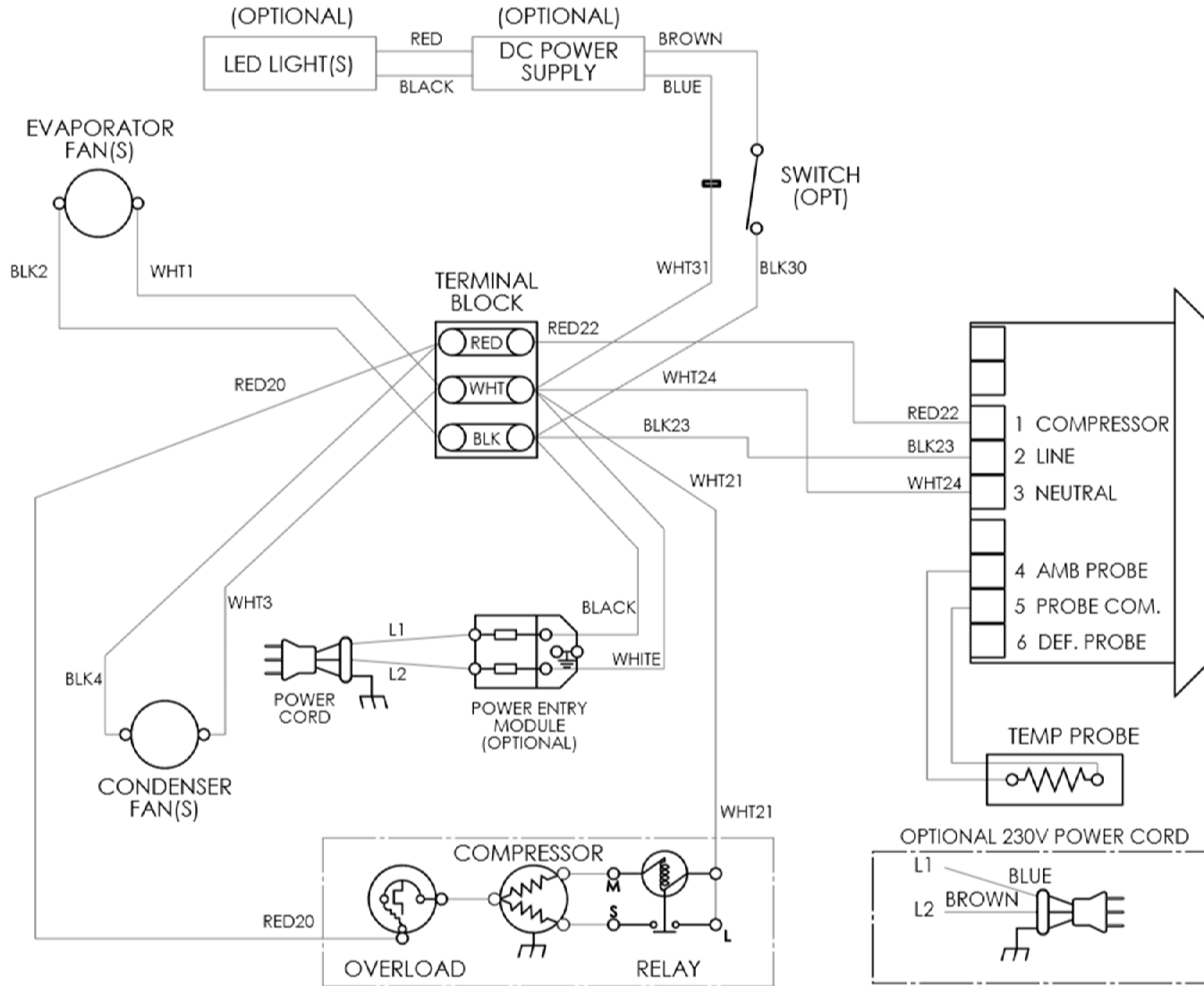

WIRING DIAGRAM 37987  
REV C

7

# Thermistor Field Testing

Thermistor Part Number [38822](#). See form M164 for the standard operating procedure.

- **Establish Thermistor Temperature**

- Check the display's temperature reading.
- If a thermometer is available, use it to confirm the display's temperature reading by taking the temperature at the thermistor.
- If the previously stated tasks are unavailable, then use any reasonable means to estimate the thermistors temperature.

- **Multimeter Set-up**

- Use a multimeter and set it to the resistance ( $\Omega$ ) setting. See Figure 1.
- Disconnect the thermistor from the controller, then connect the multimeter to the thermistor. See Figure 1.
- Check and compare the multimeter's reading to Table 1.

- **Analyze Results**

- If the resistance and temperature are similar, then the thermistor is working properly and does not need to be replaced.
- If the resistance and temperature are not similar or the resistance's value is not on Table 1, then the thermistor is not working properly and needs to be replaced.
- If the resistance reads over-limit, then the thermistor is not working properly and needs to be replaced.

Table 1

Temp (°F)	Ohms (k $\Omega$ )	Temp (°C)
-22.0	114.56	-30
-18.4	103.18	-28
-14.8	93.07	-26
-11.2	84.06	-24
-7.6	76.03	-22
-4.0	68.87	-20
-0.4	62.46	-18
3.2	56.71	-16
6.8	51.56	-14
10.4	46.94	-12
14.0	42.78	-10
17.6	39.04	-8
21.2	35.66	-6
24.8	32.62	-4
28.4	29.86	-2
32.0	27.37	0
35.6	25.11	2
39.2	23.06	4
42.8	21.20	6
46.4	19.51	8
50.0	17.98	10
53.6	16.58	12
57.2	15.3	14
60.8	14.13	16
64.4	13.07	18
68.0	12.09	20
71.6	11.2	22
75.2	10.38	24
78.8	9.63	26
82.4	8.95	28
86.0	8.31	30
89.6	7.73	32
93.2	7.2	34

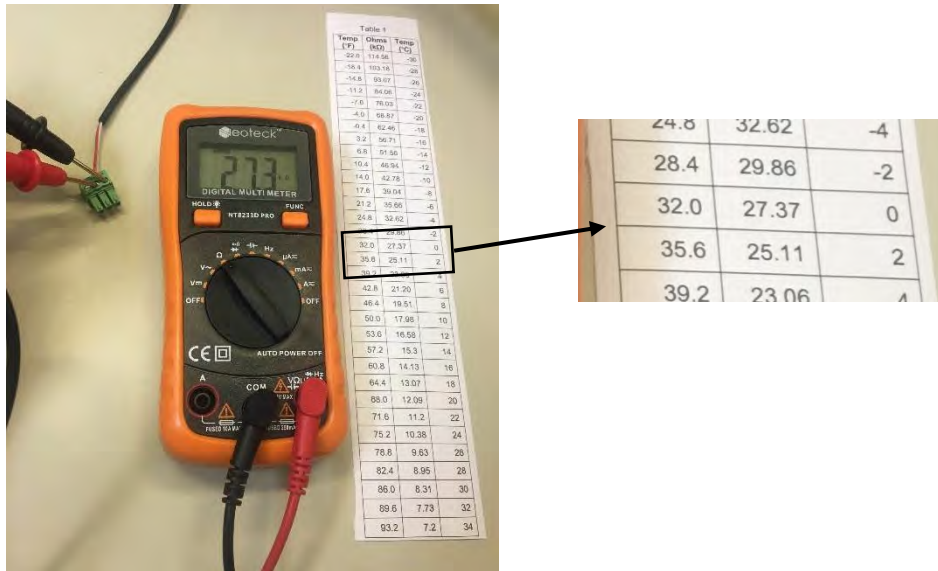

Figure 1

## **SILVER KING WARRANTY – LEGACY PRODUCT LINE**

Silver King warrants to the original purchaser of every new Silver King Legacy refrigerated self-contained unit (as defined below), that the Equipment shall be free from defects in material and workmanship under normal use and service as outlined in the Technical Manual for a period of one (1) year from the later of either (a) the date of shipment from the manufacturer or (b) the date of installation (the “Warranty Period”), but in no event shall the Warranty Period commence later than six (6) months from the date of shipment from the manufacturer unless otherwise agreed upon by the parties in writing. Equipment includes General Market Refrigeration units and excludes all Dispensing and Custom Holding Refrigeration or extended agreements whose written terms are conditional at time of sale or contract. All warranties are subject to specific limitations outlined below.

This Equipment warranty does not apply to: Repair or replacement required as a result of carelessness or neglect. Improper installation, incorrect voltage supply, modifying, tampering with or altering components and/or Equipment. Failure to perform proper maintenance. This warranty does not apply to damage resulting from fire, water, burglary, accident, abuse, misuse, transit, acts of God, terrorism, attempted repairs, improper installation or maintenance by unauthorized persons, and does not apply to food loss. Unit is compromised by adding excess weight or adhering non-approved components to the frame. Combining the equipment with hardware, fixtures, accessories or other equipment not provided by Silver King. Misuse of the Equipment or use of the Equipment not in accordance with the Technical Manual. Warranty excludes consumables or replacement components such as shelving, trays, gaskets, etc. Warranty excludes interior liner or exterior shell. Condensing coils must be cleaned at regular intervals. Failure to do so can cause compressor malfunction and will void warranty. Although cleaning requirements vary in accordance with operation of various products, Silver King advocates a minimum monthly cleaning.

The Equipment warranty does not include freight, handling, installation, labor (following the (1) year labor warranty period) or other incidental or consequential costs including product and/or economic loss. This Equipment warranty is in lieu of all other warranties, express or implied, are hereby disclaimed and excluded including those of merchantability, and fitness for a particular purpose. This Equipment warranty is non-transferable. Specific provisions of this Equipment warranty are as follows:

**90 DAY REPLACEMENT PARTS WARRANTY** Silver King warrants to the original Equipment purchaser that a replacement OEM part thereof will be free of defects in material and workmanship, under normal use and service, for a period of 90 days from the date of original purchase of such replacement OEM part subject to all terms and conditions herein.

**LIFETIME HINGE AND HANDLE WARRANTY** Silver King provides a lifetime warranty on hinges and primary (door or drawer) handles. In the event of a non-conforming hinge or primary handle, Silver King shall provide a replacement part; however, Purchaser shall be responsible for any other replacement costs, including but not limited to shipping, installation and labor.

**Three (3) Year Drawer Slide Warranty** Silver King warrants to the original Equipment purchaser for a period of time not to exceed the earlier of the following: three (3) years from the date of original purchase of the Equipment or three (3) years and six (6) months from the date of shipment from the factory of the equipment, that it will replace the drawer slides with one of similar design and capacity, exclusive of delivery and installation charges, if it is found in Silver King’s review to be inefficient or inoperative due to defects in material or factory workmanship.

**FIVE (5) YEAR COMPRESSOR WARRANTY** Silver King warrants to the original Equipment purchaser for a period of time not to exceed the following: five (5) years from the date of original purchase of the Equipment or five (5) years and six (6) months from the date of shipment from the factory of the Equipment, that it will replace the compressor with one of similar design and capacity, exclusive of delivery and installation charges, if it is found subject to Silver King's review to be inefficient or inoperative due to defects in material or factory workmanship. It is the original purchaser's responsibility to return the serial plate of the defective compressor, or at Silver King's option the complete compressor, to the factory. Failure to do so will void this limited compressor warranty. This limited compressor warranty shall be limited to parts only after the WARRANTY period applicable to the Equipment has expired.

This Equipment warranty is limited to repairing or replacing any parts that, at Silver King's discretion, are deemed to be defective within the time period covered by this warranty. The three (3) year parts warranty covers standard freight and handling charges. Special handling charges or expedited means for transport are excluded from reimbursement. Use of non-OEM parts may, at Silver King's discretion, void this warranty. If approved, warranty credit for non-OEM parts will be issued at the OEM cost. Replacement parts sold separately are warranted for 90-days from date of purchase. Special installation/applications, including remote locations, are limited in coverage by this warranty. Any installation that requires extra work, and or travel, is the sole responsibility of the equipment purchaser.

**ADDITIONAL WARRANTY GUIDELINES:** A factory issued Service Authorization Number must be obtained prior to work being performed under the (1) one-year labor warranty. Contact your supplier or Silver King. Claims submitted without a Service Authorization Number will be paid at Silver King's discretion. The labor warranty includes standard straight time labor charges in accordance with Silver King's Labor Warranty Guidelines and reasonable travel time, as determined as determined in the Silver King time – rate guide.

Silver King, at its discretion, may request photos during or prior to service being dispatched to validate a technical issue. Failure to comply with the request may result in the cost of service being the responsibility of the service requestor or site.

The labor warranty does not cover original installation, startup, normal adjustments or maintenance. Normal adjustments and maintenance include, but are not limited to; temperature control adjustments, temperature indicator calibrations, coil and filter cleaning, or condensate drain cleaning.

A second service call for a related failure is not covered.

Use of refrigerants other than specified on the Equipment serial plate voids the warranty. All claims must include; model and serial number of equipment, date of purchase, date of failure, and a copy of the service invoice detailing the defect and service performed. No claim will be processed without this information. All claims must be filed within 30 days from date of service.

**PRODUCT ORDERING INFORMATION** Call us toll free at 1-800-328-3329 or 1-763-923-2441 Fax us at 1-763-553-1209

Visit [www.silverking.com](http://www.silverking.com) for stocking distributor, equipment specs and current price list for your area.

**SERVICE / PARTS ORDERING INFORMATION** Call us toll free at 1-800-328-3329, prompt 1 Equipment Service and Tech Support or 2 Parts

TERMS AND CONDITIONS • This price list and conditions are effective January 1, 2020 and supersedes all previous price lists. • WARRANTY period may vary from customer to customer and is contract specific. • All prices reflect payment in U.S. Dollars. • Prices do not include any freight, duty, or taxes. • Pricing subject to change without notice. • No returns are accepted without prior written approval from the factory. An RMA (Returned Merchandise Authorization) form must be completed and then approved by Silver King. Please contact Silver King for details. Restocking fee will apply. • All electrical equipment is single phase. • Prices, designs, and specifications are subject to change without notice. • Payments via credit card are subject to a 3.5% surcharge. •

Any and all environmental attributes, including environmental offset credit rights, with respect to Silver King refrigeration units manufactured after September 1, 2015, shall remain the property of Silver King and are not transferred.

IN NO EVENT SHALL SILVER KING BE LIABLE FOR CONSEQUENTIAL, SPECIAL OR PUNITIVE DAMAGES. THE REMEDIES OF PURCHASER SET FORTH HEREIN ARE EXCLUSIVE AND THE TOTAL LIABILITY OF SILVER KING, WHETHER BASED ON CONTRACT, WARRANTY, NEGLIGENCE, INDEMNIFICATION, STRICT LIABILITY, TORT, OR OTHERWISE, SHALL NOT EXCEED THE PURCHASE PRICE OF THE COMPONENT UPON WHICH LIABILITY IS BASED. SILVER KING SHALL HAVE NO OBLIGATION OR LIABILITY FOR CONSEQUENTIAL OR SPECIAL DAMAGES, INCLUDING BUT NOT LIMITED TO INDIRECT, PUNITIVE DAMAGES, LOSS OF USE, LOSS OF PRODUCT, DOWNTIME OR LOST PROFITS, ARISING OUT OR, RELATED TO OR CONNECTED IN ANY WAY WITH THE PRODUCT OR ITS USE.

Silver King 1600 Xenium Lane, Plymouth, MN 55441-3706 [www.silverking.com](http://www.silverking.com) • 1-800-328-3329

© Silver King 2019 Prices Subject To Change

*Note: Additional Terms and Conditions of sale may apply. Notice: Specifications Subject to Change Without Notice. Contact factory for specific model agency approval.*