

Sunpak S34-TSH

Outdoor Gas Infrared Patio Heater

NOT FOR USE IN RESIDENTIAL DWELLINGS

Installation, Operation and & Maintenance Instructions

NOTE: Heater above shown with optional Face Trim

Installer: Please take the time to read and understand these instructions prior to installation. Installer must provide a copy of this manual to the owner.

Owner: Keep this manual in a safe place in order to provide your service technician with the necessary information.

Warning: These instructions are intended for qualified personnel, specifically trained and experienced in the installation and repair of this type of equipment and related system components.

IF NOT INSTALLED, OPERATED AND MAINTAINED IN ACCORDANCE WITH THE MANUFACTURER'S INSTRUCTIONS, THIS PRODUCT CAN EXPOSE YOU TO SUBSTANCES IN THE FUEL OR FROM COMBUSTION INCLUDING CARBON MONOXIDE RESULTING IN DEATH OR SERIOUS ILLNESS AND WHICH ARE KNOWN TO THE STATE OF CALIFORNIA TO CAUSE CANCER, BIRTH DEFECTS OR REPRODUCTIVE HARM.

For more information go to www.P65WARNINGS.CA.GOV

Infrared Dynamics, Inc

3830 Prospect Avenue

Yorba Linda, CA 92886

<http://sunpak.us>

For Local Distributor Listing

Call Us Toll Free

(888) 317-5255

<p>Table of Contents</p> <ol style="list-style-type: none"> 1. Warnings 2. Basic Operation 3. Heater Layout and Design 4. Installation / Service 5. Replacement Parts 6. Trouble Shooting Guide 7. Warranty 	<p>Sunpak heaters work like the sun projecting radiant heat down to warm your patio and guests. This heater was designed for outdoor installation; however, breezes will affect the heating efficiency, and severe weather conditions will cause the safety system to shut down the heater. For your safety you must read and understand the following warnings before continuing.</p>
<p>⚠ WARNING</p>	
<p>Improper installation, adjustment, alteration, service or maintenance can cause death, injury or property damage. Read and understand the installation, operating and maintenance instructions thoroughly before installing or servicing this equipment.</p>	<p>Storage of gasoline and other flammable vapors and liquids in the vicinity of this or any other appliance may result in fire or explosion. DO NOT store or use gasoline or other flammable vapors and liquids in the vicinity of this or any other appliance. Always maintain clearance to combustibles as specified.</p>
<p>⚠ WARNING</p>	
<p>Not for use in residential dwellings.</p> <p>This heater is not approved for use in any indoor residential applications. This includes, but is not limited to, attached garage, solarium, living quarter, etc. Installation in residential indoor spaces may result in death, asphyxiation, serious injury, or property damage.</p>	<p>For Your Safety</p> <p>If you smell gas:</p> <ul style="list-style-type: none"> • Shut off gas to the appliance • Extinguish any open flame • DO NOT touch any electrical switch • Call your gas supplier. DO NOT use any phone in your building. • Follow the gas supplier's instructions. • If you cannot reach your gas supplier call the fire department

Basic Heater Operation

Sunpak® S34-TSH is a two-stage outdoor gas-fired infrared heater which is operated with a wired switch. The heater can be operated at a HIGH setting with an input of 34,000 BTU/Hr or at a LOW setting of 25,000 BTU/HR. These heaters require a 24 VAC power source.

The fact that these heaters are hardwired to a three-way switch makes the S34-TSH well suited for commercial installations. There are no batteries or remote-control devices to be misplaced. The robust lighted switch makes it easy to see whether the heater is ON. Switch is prewired specifically for the Model S34-TSH. Switch is made for 24 VAC only.

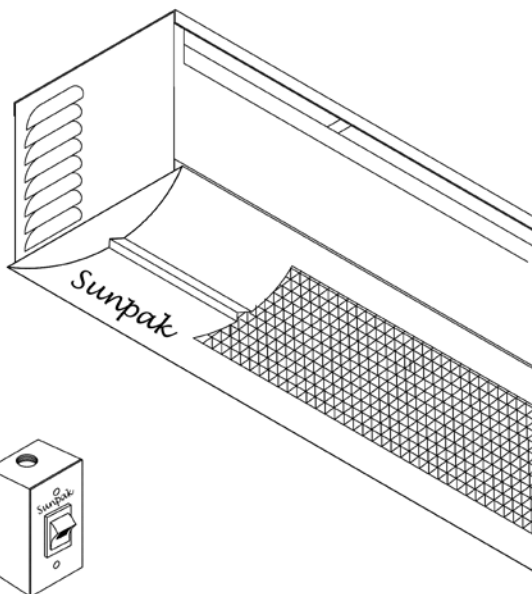

NOTE: Sunpak Heater shown with optional Face Trim

The Sunpak® S34-TSH should always be started up and operated on the High mode for the first 5 minutes to allow the heater to warm up. Starting up the heater on the LOW mode before the heater is warmed up may cause the heater to shut down prematurely. To correct this situation, press the OFF followed by HIGH.

Sunpak® heaters have a spark ignition and electronic flame safety control. The pilot is only ON while the heater is operating. If the flame safety sensor fails to sense flame at the pilot, the heater will shut down and lockout. This may happen due to low gas pressure or a gusty wind. To restart the heater, first set the switch to OFF before restarting the heater.

Although these heaters are designed for outdoor installation and use, it is important that switches, transformers or other operating controls be protected from the weather.

The TSH Switch with light is intended for 24 VAC only. Two input wires hook up to the 24 VAC Transformer. Polarity must be observed if you are connecting two or more heaters. Three output wires connect to the heater for common, low fire and high fire. The blue light on the switch shines continuously whenever the heater is on.

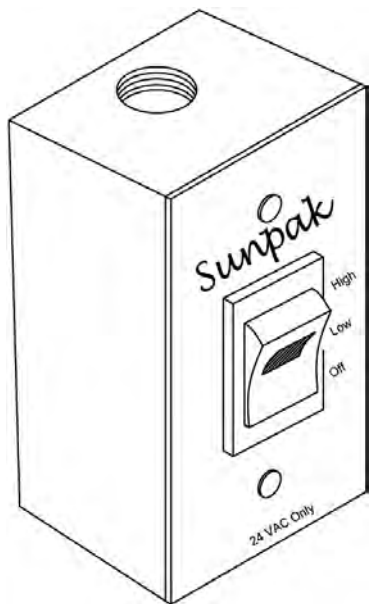

Part No. 12052
TSH Switch with Light

Heater Layout and Design

Sunpak® heaters were specifically designed to provide heated comfort in an outdoor environment. They have been used on outdoor patios across the United States and Canada for over 30 years. When properly integrated into a patio design, Sunpak® heaters generally increase the comfort level 5° to 10° Fahrenheit outdoors. The heating effectiveness will depend on air temperature, wind velocity and other factors. Whenever possible other local Sunpak® installations should be reviewed to determine the effectiveness for regional environment.

The environments in which Sunpak® heaters are utilized vary greatly. As an outdoor rated heater it has passed basic wind and rain tests. This does not mean the heater cannot be damaged by the environment or when operated in very windy conditions. For this reason it is strongly suggested that heaters be inspected and if necessary repaired annually or before each heating season.

The variable environments in which Sunpak® heaters are applied means that these general guidelines are generated by necessity and may need to be refined for local conditions. These guidelines are to be used in combination with the installation instructions.

Patio Design Consideration

Heater placement is critical for effective and efficient patio heating. If heaters are placed too close together or mounted too low, people become uncomfortable. If heaters are placed too far apart on a breezy, wind-swept patio the patio may never get warm.

Sunpak® heaters work best if they are placed in areas of the greatest heat loss, such as the open side of a semi-protected patio area. The Sunpak® heater may be mounted at up to a 30 degree angle or face down. Note that the top clearances required from combustible material increases when heaters are at an angle. The heater must always be horizontal to the floor. **Never mount the heater in the vertical position.**

Breezy conditions must be considered when heating any patio. Windbreaks can be extremely effective in increasing comfort and reducing heating costs. Windbreaks must be designed in such a way as to allow the necessary fresh air and ventilation for proper heater operation (see ventilation of installation section).

Sunpak® heaters must always be operated in a location that allows uniform air pressure around the heater. If only part of the heater is located in a wind protected zone damage to the heater may occur. Time should be taken to observe how the wind will affect the heaters under local conditions.

MINIMUM CLEARANCE FROM COMBUSTIBLE MUST BE MAINTAINED (see chart on page 6 & 7)

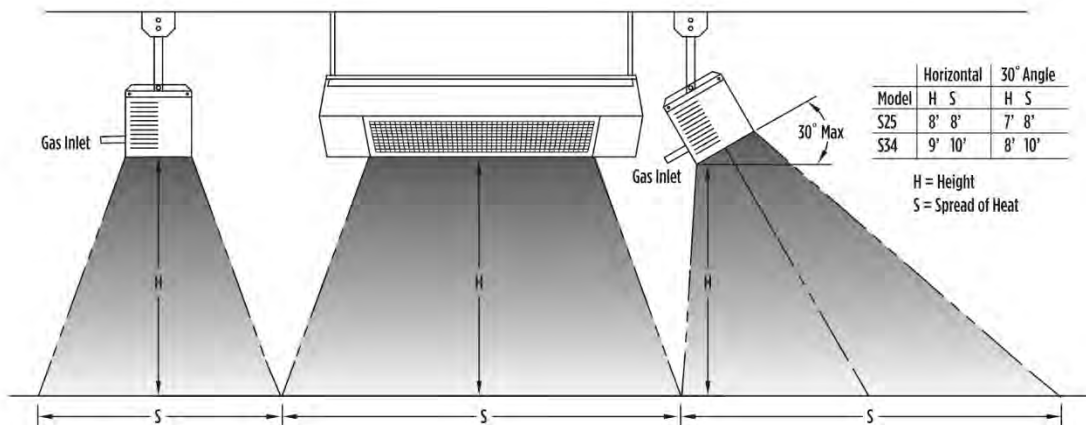

SUNPAK will raise the comfort level 5-10° Fahrenheit outdoors. The above coverage table was based on still breeze conditions. Under windy conditions more heat will be required. It is recommended that a windswept patio be designed with wind breaks to stabilize the patio environment. Wind breaks shall NOT interfere with the ventilation or combustion air requirements of the heater(s) and meet clearance for combustible requirements listing on page 6 & 7.

WARNING: Severe updrafts such as you might get on a raised terrace or roof top patio can cause damage to the heater.

ANGLE MOUNTING: Most applications of the SUNPAK® heater may be angle-mounted to a maximum of 30° to accommodate mounting the heaters around the edges of the patio. Note that the top clearance to combustibles increases when heater is tipped from the horizontal.

NOTE: Local codes may have special requirements regarding head clearance requirements. Some local codes require all portions of overhead radiant heaters to be located at least 8 feet above the floor.

Sunpak® Infrared Heater Location

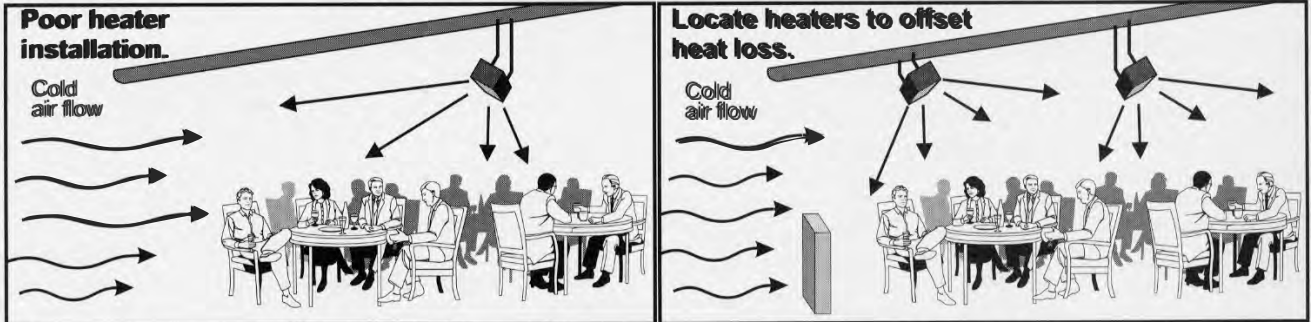

Suggested Installation Configurations

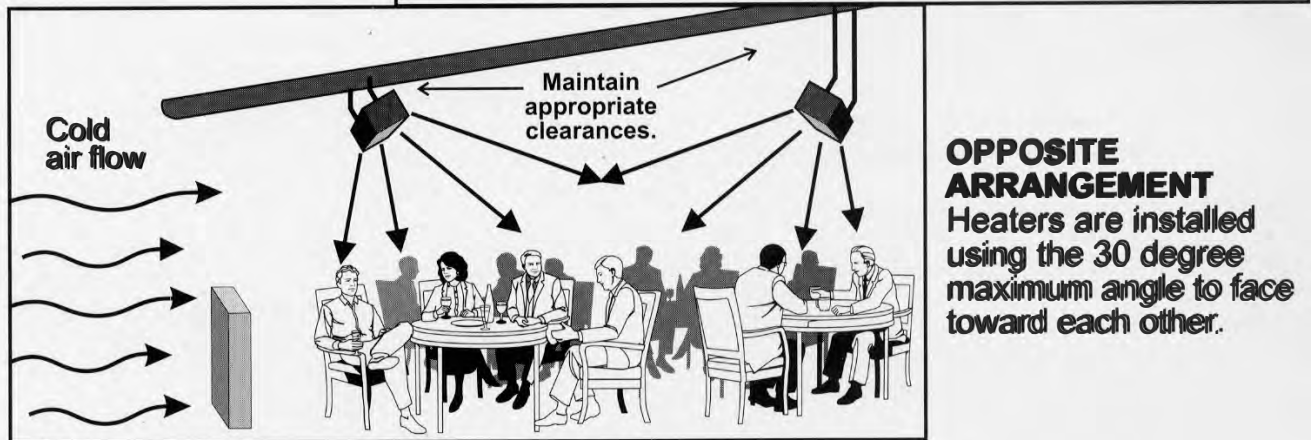
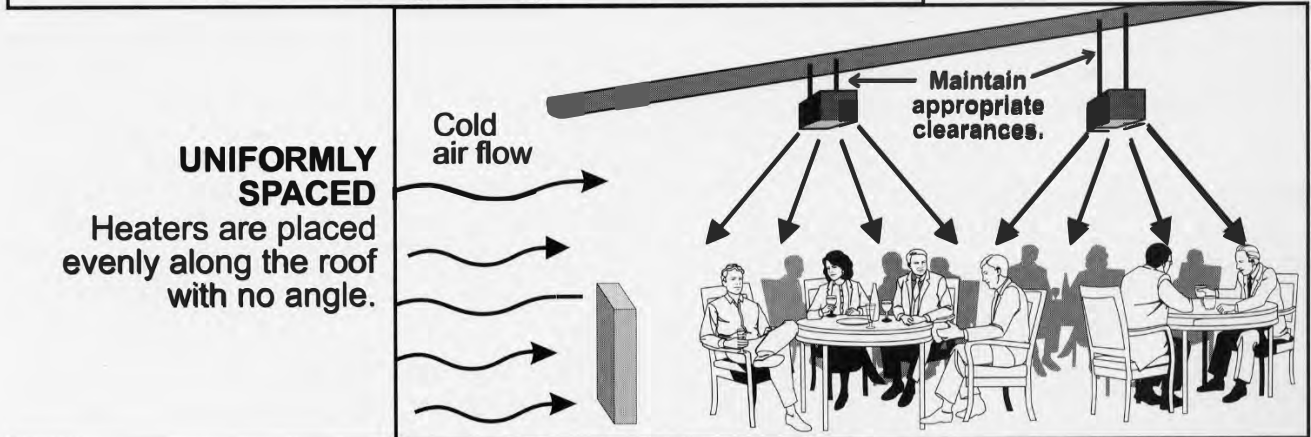
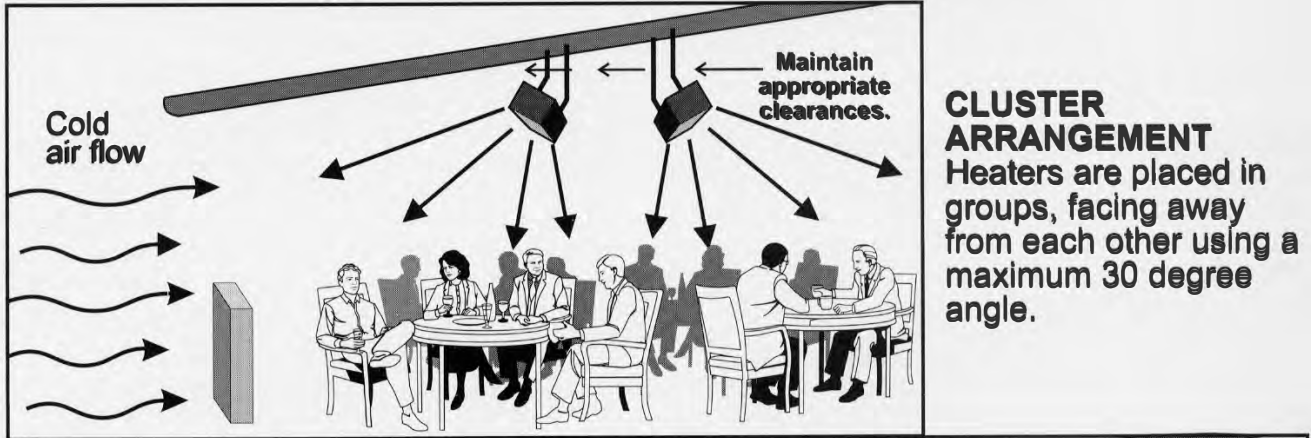

SUNPAK® S34-TSH INFRARED HEATERS

SUNPAK® INFRARED HEATERS

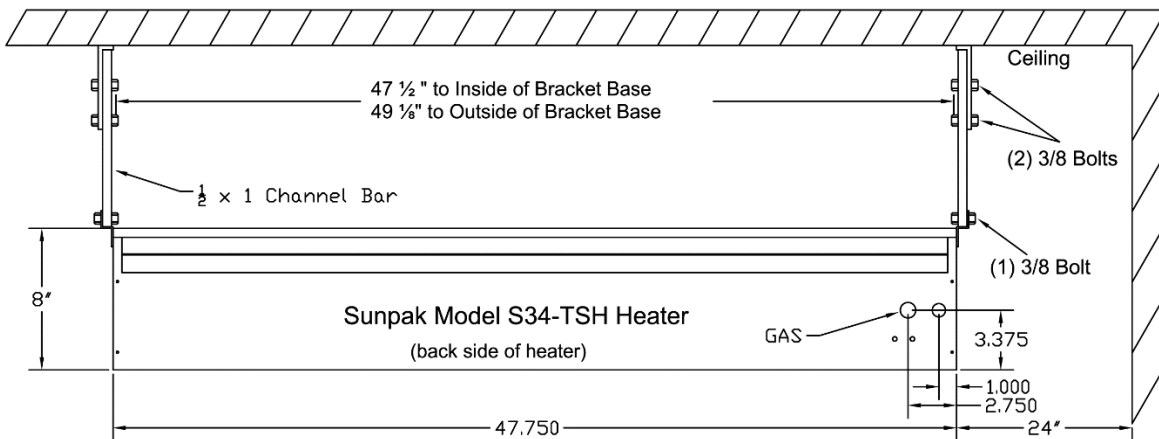
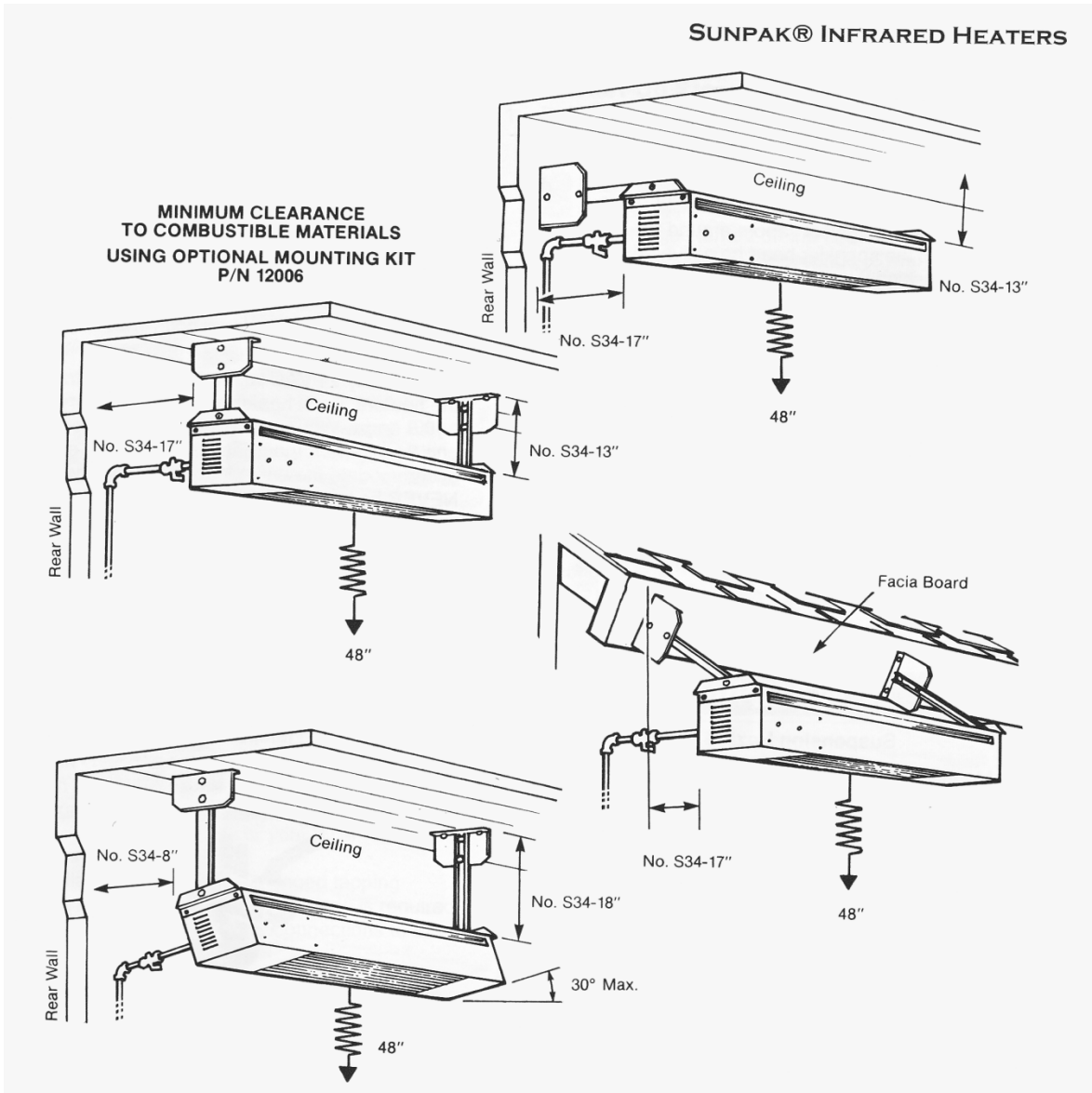

Warning: Heater must be level in the lengthwise direction.

Installation/Service Instructions

Receiving Equipment

On receipt of equipment it is suggested that a visual inspection be made for external damage to the carton. If the carton is damaged, a note should be made on the Bill of Lading when signing for the equipment. Remove the heater from the carton. **If there is damage, report the damage to the carrier immediately.**

INSTALLATION INSTRUCTIONS

Important Notice

These instructions are intended for qualified personnel, specifically trained and experienced in the installation of this type of equipment and related system components. Some states or provinces require installation and service personnel to be licensed. If your state or province is such, be sure your contractor bears the appropriate license. Persons not qualified shall not attempt to fix this equipment nor attempt repairs.

WARNING

Asphyxia, Explosion or Fire

Improper installation, adjustment, alteration, service or maintenance may create a hazard resulting in asphyxiation, explosion or fire, or damage to the equipment.

Code Requirements

Installation must be in accordance with local codes, or in the absence of local codes, with the latest edition of the National Fuel Gas Code, ANSI Z224 and National Electrical Code ANSI/NFPA 70, and for Canada, the latest edition of CAN/CGA-B149.1 and B149.2 and Canadian Electrical Code, CSA C22.1 Part 1 and Part 2.

- Heaters to be installed in Aircraft hangars must be installed in accordance with American National Standards for Aircraft Hangars, ANSI/NFPA No. 409.
- Heaters to be installed in Public Garages must be installed in accordance with NFPA No. 88A, Standards for Parking Structures.
- Heaters must be installed so that minimum clearances marked on the heaters will be maintained from vehicles parked below the heater.
- Each heater must be electrically grounded in accordance with the National Electrical Code, ANSI/NFPA 70, when an external electrical source is utilized. In Canada, the CSA Canadian Electrical Code, C22.1 Part 1 applies.

Gas Supply

The gas inlet supply pressure and manifold pressures required for each heater are listed below. For gas supply line pressures in excess of ½ PSI, consult with your gas service provider or the factory.

Gas Inlet Pressure	Nat Gas	Propane
Maximum Pressure	½ PSI	½ PSI
Minimum Pressure	6" W.C.	11" W.C.
Manifold Pressure	5" W.C.	10" W.C.

It is critical that the gas piping system be adequately sized for all the gas appliances it serves.

Clearances

Each heater must be installed such that the following "Minimum Clearance to Combustible Materials" are maintained. Combustible materials include wood, compressed paper, plant fibers, plastic, Plexiglas or other materials capable of being ignited and burned. Such materials shall be considered combustible even though flame-proofed, fire retardant treated or plastered. Additional clearance may be required for glass, painted surfaces, vinyl siding or other materials which may be damaged by radiant or convection heat.

Adequate space around each heater is required even when the materials surrounding the heater are non-combustible to provide adequate combustion air and ventilation of exhaust gases. Heaters should never be located in a ceiling recess or any form of ceiling enclosure.

The stated clearance to combustible materials represents a surface temperature of 90°F (32°C) above room temperature. Building materials with a low heat tolerance (such as plastic, vinyl siding, canvas, tri-ply, etc.) may be subject to degradation at lower temperatures. It is the installer's responsibility to assure that adjacent materials are not subject to degradation.

In locations used for storage of combustible materials, signs shall be posted to specify the maximum permissible stacking height to maintain required clearances from the heater to combustible materials.

OPTIONAL MOUNTING KIT (#12006): Optional Mounting Kit is included in some packages. Whether the mounting kit is used or not, minimum clearance from combustibles must be observed as follows:

WARNING: The clearances shown below are also applicable to vehicles parked below heaters.

	Input	Side	Rear	Ceiling	Below	Mtg.
Model	BTUH	In	In	In	In	Angle
S34	34,000	24"	17"	13"	48"	HORIZ
S34	34,000	24"	8"	18"	48"	30° MAX

SUNPAK® INFRARED HEATERS

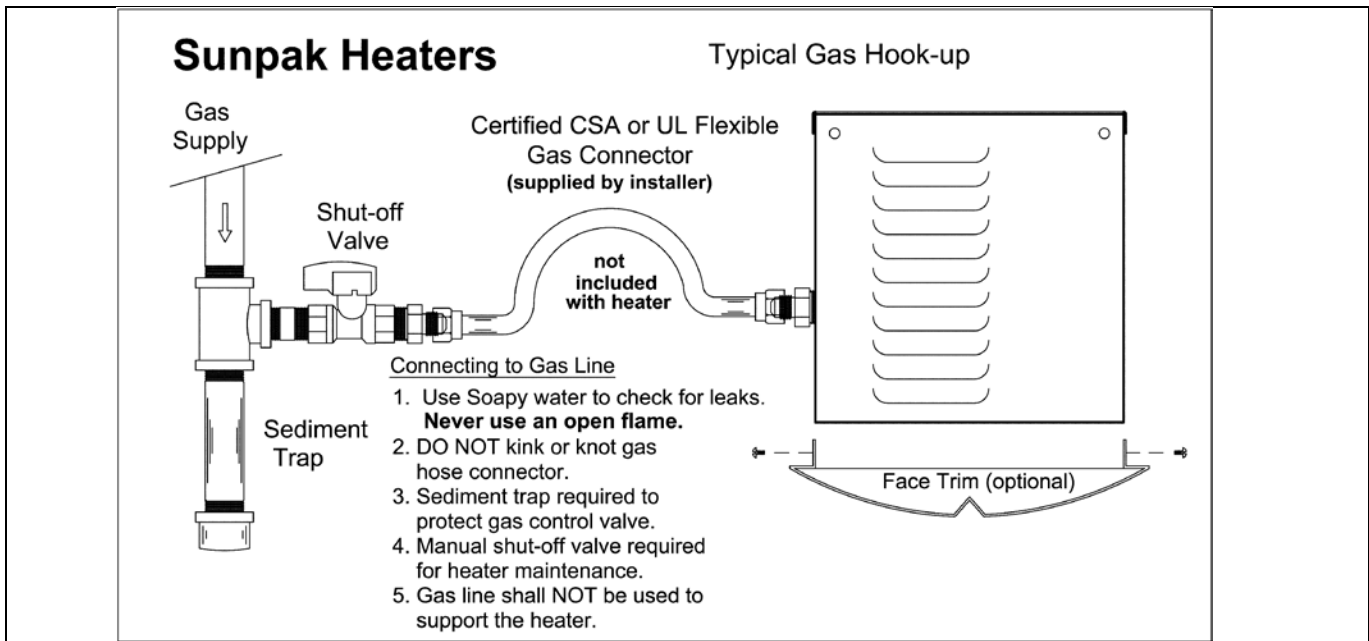

WARNING

Suspension Hazard

Mounting kits and hanging supports must be able to withstand a minimum working load of 75 lbs. (33 kg). Failure of the supports can result in death.

Local codes regarding head clearance requirement must be observed.

Heater Mounting and Support

Heaters shall be mounted in a fixed position independent of gas and electrical supply line. Hangers and brackets shall be of noncombustible material.

Heaters subject to vibration shall be provided with vibration isolating hangers.

Suitable materials for hanging infrared heaters are steel pipe, steel channel, or fabricated hangers of at least 16-gage material. Hanger and brackets must be secured with adequate anchor to a secure structure using good building practices. Additional bracing to protect against seismic forces may be required in seismically active areas. Never mount heaters to a moving object such as a trailer, motor home, boat, etc.

Gas Piping

1. A minimum pipe size of ½" is required for inlet piping. A ½" lever handled gas shut-off valve should be installed within 6 feet of the appliance for servicing and as emergency shutoff to the unit.
2. Check with local and state plumbing and heating codes regarding sizing of gas lines.
3. All gas pipe connections to the heater(s) must be sealed with a gas pipe compound resistant to liquefied petroleum gases.
4. Installation of a drip leg or sediment trap in the gas supply line going to each heater is required to minimize the possibility of any loose scale or dirt within the gas supply line from entering the heater's control system.
5. When checking for gas leaks, do not use an open flame. Use a soap and water solution.
6. For gas supply line pressures in excess of ½ PSI, consult the factory or your local representative.
7. Installation of 1/8" N.P.T. plugged tap accessible for test gage connections is required upstream of the gas supply connections to the heater.
8. Never use pipe sealing compound on brass to brass flared fittings.

Electrical

1. Sunpak S34-TSH Heaters need 24 VAC to operate. A special lighted switch is provided which also requires 24 VAC. In sizing your step down 120V/24V transformer always allow for a current draw of 20 VA per heater. A 24V – 40VA transformer will operate two heaters.
2. If any of the original wire supplied **inside** the appliance must be replaced, it must be replaced with wiring material having a temperature rating of at least 105 degrees Centigrade.

SUNPAK® INFRARED HEATERS

Ventilation

1. It is required that areas above the heater be properly vented to allow for necessary combustion air and removal of combustion gases.
2. Heaters shall be provided with natural or mechanical means to supply and exhaust at least 4 cfm per 1,000 BTU per hour of heater input. Exhaust openings for removing the flue products shall be above the level of the heaters.
3. Heater ventilation must comply with state and local codes. **Never use heater in a fully enclosed area.**

Fire Sprinklers

Fire Sprinklers must be located at an appropriate distance from each heater to avoid accidental activation of the sprinkler. Ethylene glycol or propylene glycol must never be used in fire sprinkler systems where heaters are present as these substances may become flammable when heated. A fire sprinkler professional must be consulted when heaters are installed where fire sprinklers are present to insure that heaters and the fire sprinkler system are properly integrated. Specific guidelines can be found in NFPA 13 regarding design and specifications for Fire Sprinkler Systems near heaters.

Initial Start-Up Procedure

(Read entire Procedure First)

1. Before turning ON your new heater make sure:
 - a. Heater is securely mounted and clearances from combustible materials have been observed (see Clearances – page 7);
 - b. Tip angle of heater does not exceed 30 degrees (see Correct Mounting – page 12);
 - c. Gas line is properly connected and there are no leaks (see Gas Piping – page 8);
 - d. Make sure 24 VAC is properly connected to the heater. Applying 120 VAC to the heater will damage the switch and other heater controls
2. Start Heater;
 - a. Turn ON manual gas valve.
 - b. Set switch to the high setting for the first 5 minutes.
 - c. If heater locks out, switch to OFF to RESET Heater and repeat start up sequence.
 - d. If the heater locks out several times there may still be air in the gas line.

NOTE: Some white smoke may appear during or just after the initial start-up of the heater. White smoke will dissipate with proceeding use. This is normal due to some residual lubrication on a new heater

Regular Service and Maintenance

Over time, particularly during long periods of non-use, the heater can accumulate dirt and debris in and around the pilot and the burner. Routine maintenance should be performed at least once a year by a qualified service agency to insure the heater is operating properly. More frequent service may be required for heaters located near waterfronts. If local service is not available call your natural gas or propane supplier.

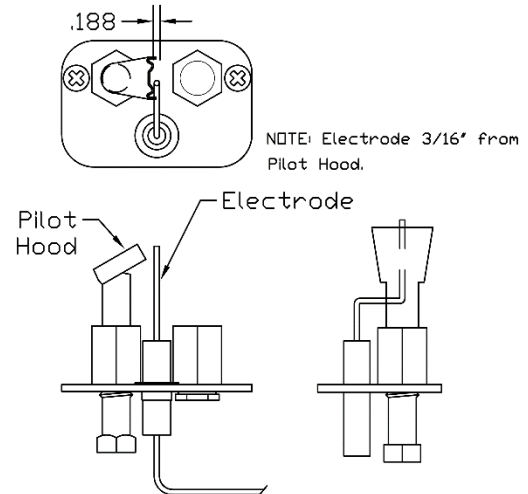

Sunpak Pilot and Electrode Position

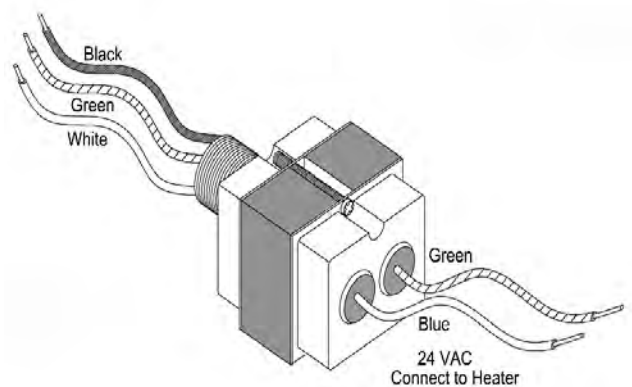

Typical 24V Transformer. Transformer should never be mounted inside heater

SUNPAK® INFRARED HEATERS

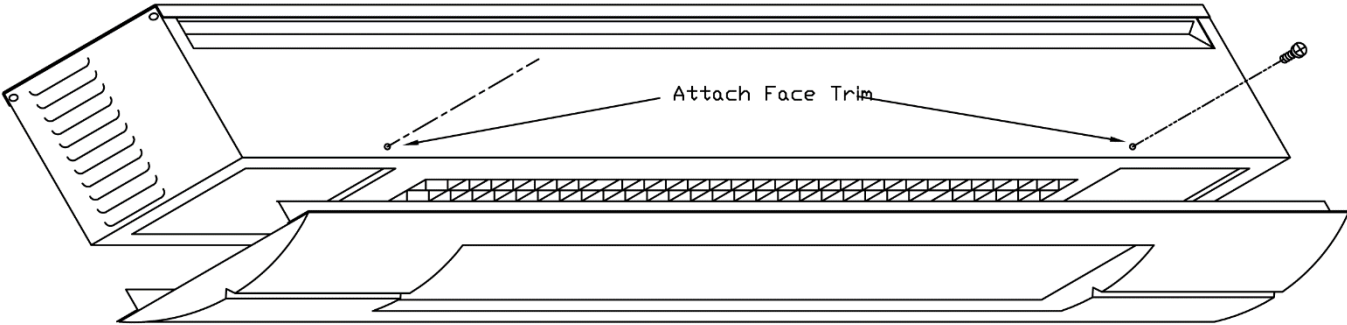

Optional Face Trim can be easily installed on all Sunpak models

You must remove the Sunpak Face Trim to connect power to the heater. The Sunpak Face Trim is secured with four (4) screws, two (2) located along each side of the heater.

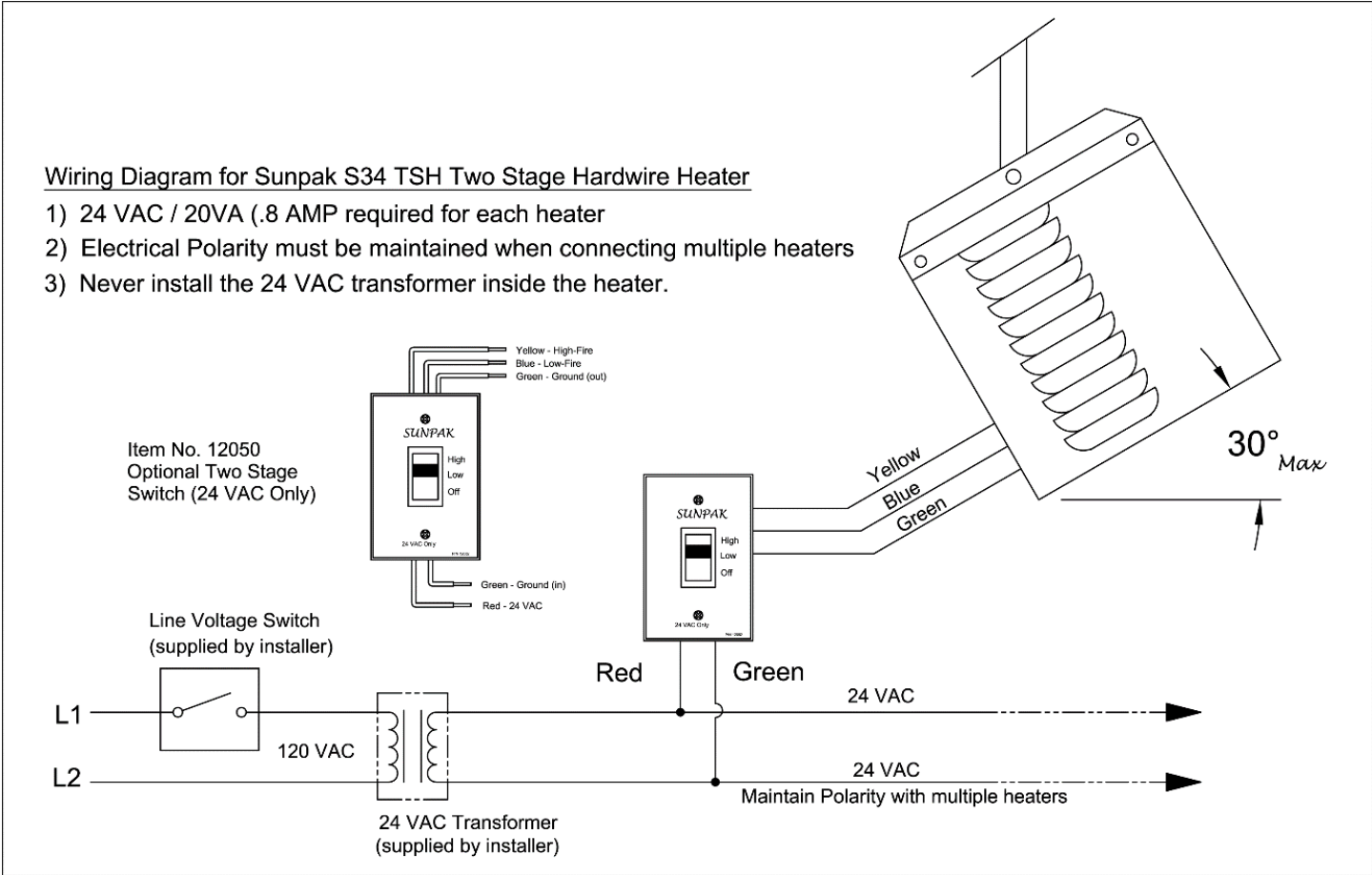

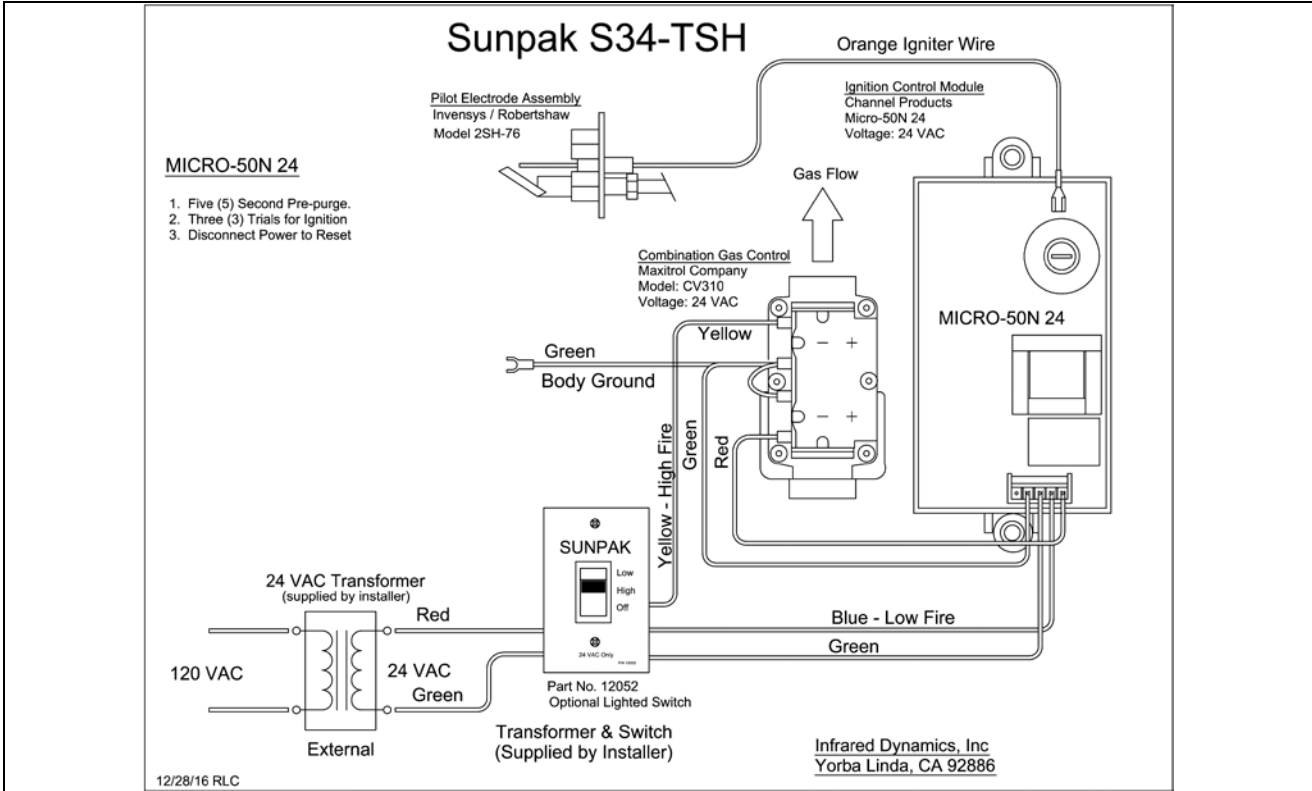

Sunpak S34-TSH

Control Components

No.	Part No.	Description
1	90073-1	Ctrl, CV310 -TSH - Natural
	90073-2	Ctrl, CV310 -TSH - Propane
2	12015	Kit, Micro Module -TSH
3	90080-2	Harness, Micro - TSH
4	80063	Elbow, Orifice Adapter
5	35001-39	Orifice, #39 dms NG
	35001-50	Orifice, #50 dms LP
6	80032	Locknut, 3/8
7	80031-5	Pilot Tubing-TSH
8	92011	Connector, 3/8 Gas
9	22024	Assy, Pilot-Elect. 2SH76
10	90015	Natural Pilot Orifice
	90016	Propane Pilot Orifice
11	12052	Assy, TSH Wall Switch

Jan 25, 2017

Sunpak Burner Replacement

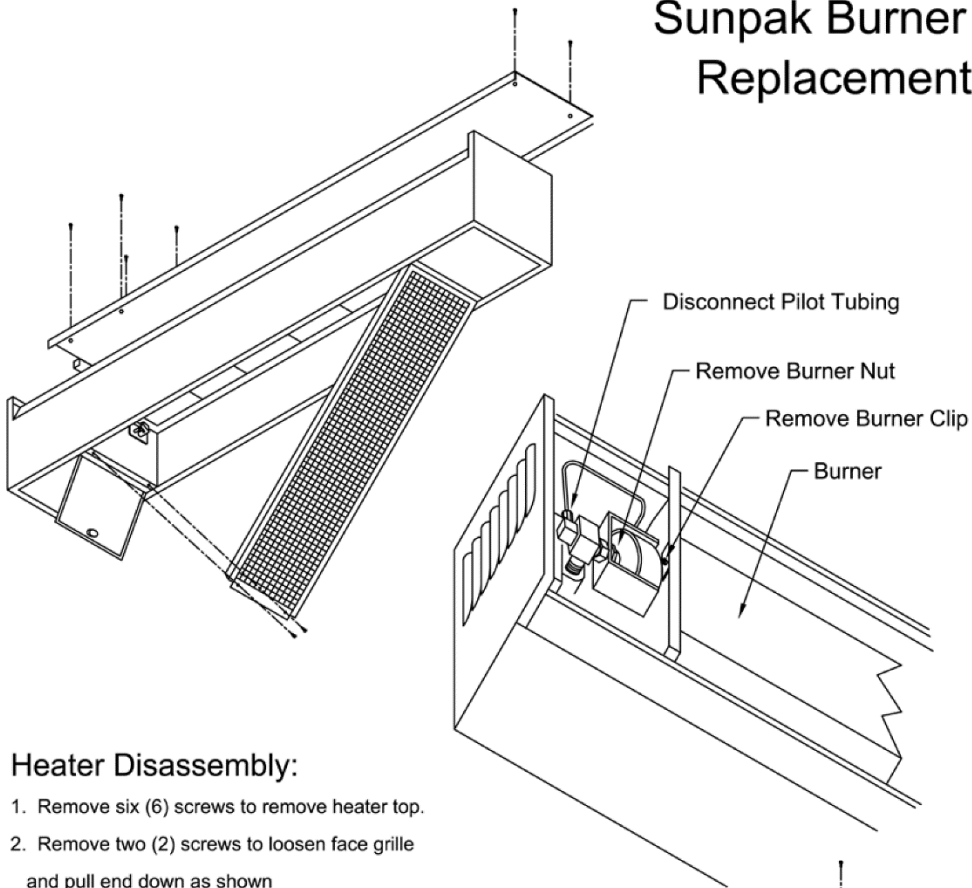

Heater Disassembly:

1. Remove six (6) screws to remove heater top.
2. Remove two (2) screws to loosen face grille and pull end down as shown
3. Disconnect gas fitting from burner.
4. Remove burner clip
5. Remove two (2) screws from far end of burner
6. Carefully remove burner
7. Reverse process to install burner.
8. Run initial Start-up Procedure

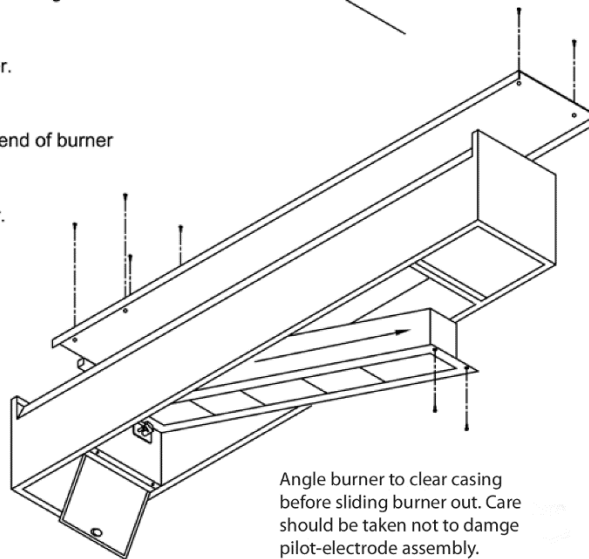

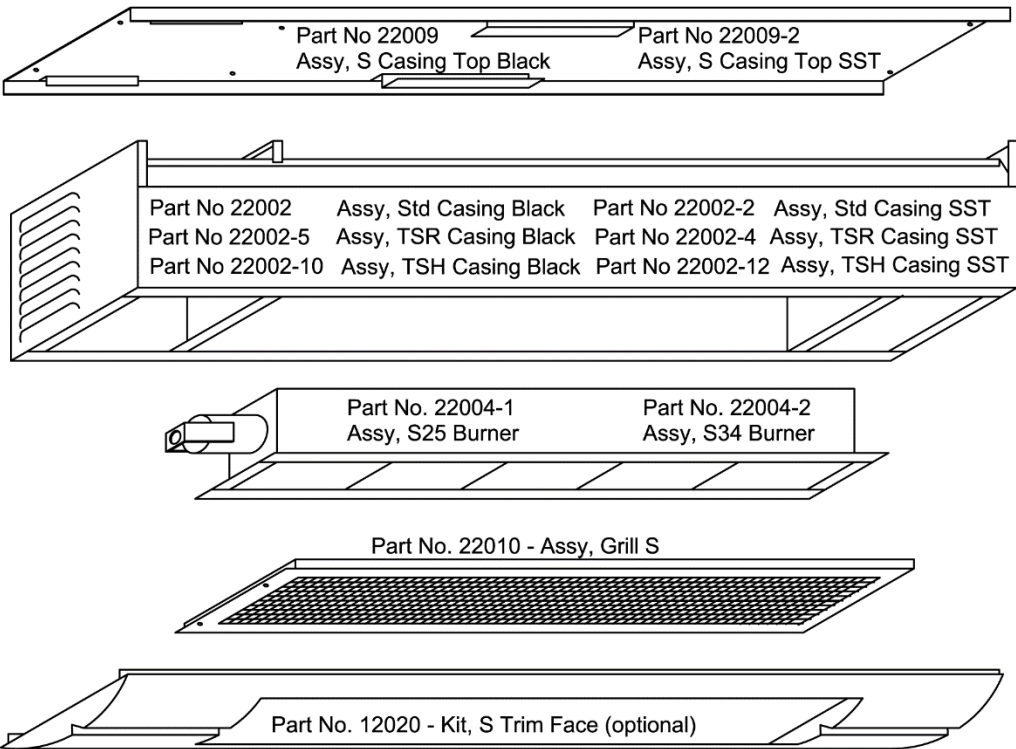

**Sunpak Heater must be mounted correctly
(Control End View)**

Angle Mounted

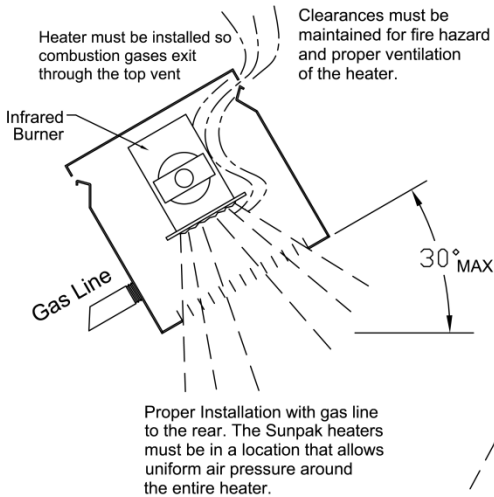

Horizontal Mounted

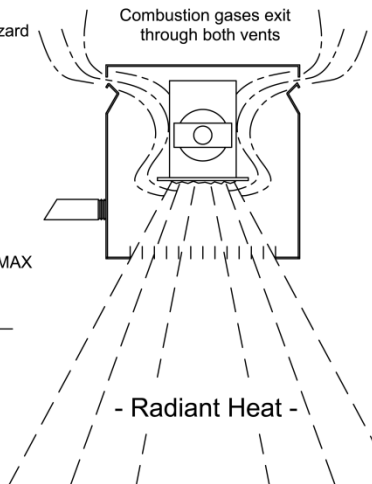

**Incorrect Mounting
will cause
damage to heater**

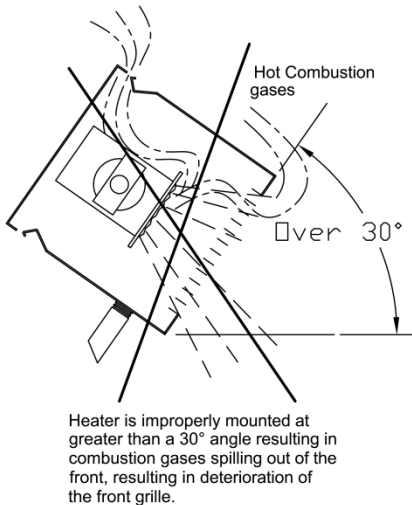

Basic TSH Trouble Shooting

Problem	Possible Causes	How to Fix	References
No Spark to pilot	No blue indicator light on switch	<ul style="list-style-type: none"> Verify power to switch Replace Switch 	
	No power to the heater	<ul style="list-style-type: none"> Switch is On Verify wiring is properly connected to the heater module 	Electrical – Page 8 Basic Wiring – Page 10
Sparks, but does not ignite burner	No Gas to Heater	<ul style="list-style-type: none"> Allow time for air to bleed from gas line on new installations Turn on manual gas valve Clean burner orifice 	Gas Piping – Page 8 Regular Service & Maintenance – Page 9
Heater lights, but turns off	Low Voltage	<ul style="list-style-type: none"> Make sure you have 24 VAC to heater 	
	Loose or broken ground wire inside control compartment	<ul style="list-style-type: none"> Secure ground wire to heater body 	Control System – Page 11
	Pilot Electrode	<ul style="list-style-type: none"> Adjust pilot electrodes 3/16 from pilot hood. Replace TSH Control Module Replace Pilot Electrode Assembly 	Sunpak Pilot – Page 9 Control Components – Page 11
Not Enough Heat	Low Gas Pressure	<ul style="list-style-type: none"> Verify required gas pressure to heater 	Gas Supply – Page 7 Gas Piping – Page 8
	Lack of Fresh Air to Heater	<ul style="list-style-type: none"> Adjust tip angle to less than 30 degrees Add ventilation to patio above and below heater 	Ventilation – Page 9
	Dirty Orifice	<ul style="list-style-type: none"> Clean orifice 	Regular Service & Maintenance – Page 9.
	Dirty Burner	<ul style="list-style-type: none"> Use bottle brush to clear any cobwebs or debris from mixer tube of burner. Use compressed air (under 30 psi) to blow through ceramic (eye protection required) 	
	Poor Heater Coverage	<ul style="list-style-type: none"> Review Heater Layout and Design 	Heater Layout & Design – Page 4
Deterioration of Front Grill	Tip Angle over 30 degrees	<ul style="list-style-type: none"> Adjust Tip Angle to less than 30 Degrees 	Incorrect Mounting – Page 13
	Wind hitting heater from below	<ul style="list-style-type: none"> Set up wind break to prevent strong breeze from hitting infrared burner face directly. Any wind break must not interfere with the safe operation of the heater. Heater must always be operated in an equal pressure environment 	Heater Layout & Design – Page 4
Burner Noise	Dirty Orifice	<ul style="list-style-type: none"> Clean orifice thoroughly or replace if necessary 	Regular Service & Maintenance – Page 9
	Dirty Burner	<ul style="list-style-type: none"> Use bottle brush to clean mixer tube of burner Use compressed air to clean ceramic burner ports (max 30 PSI) - eye protection required. 	
	Cracked Ceramics	<ul style="list-style-type: none"> Replace infrared burner 	

Limited Warranty

THIS WARRANTY IS APPLICABLE TO THE ORIGINAL OWNER ONLY, in accordance with the warranty terms and conditions specified below.

Infrared Dynamics (the warrantor) will furnish at our option the ORIGINAL OWNER, 1) a replacement Infrared Dynamics' heater or 2) a replacement part for any component part which fails before one year when for residential use. When the heater has been used for other than single family residential applications, the warranty shall be 90 days.

Service and Labor Responsibility

UNDER THIS LIMITED WARRANTY, THE WARRANTOR WILL PROVIDE ONLY A REPLACEMENT HEATER OR PART THEREOF. THE OWNER IS RESPONSIBLE FOR ALL OTHER COSTS. Such costs may include, but are not limited to:

- a. Labor charges for service, removal, or reinstallation of the heater or part thereof.
- b. Shipping and delivery charges for forwarding the new heater or replacement part from the nearest distributor and returning the claimed defective heater or part to such distributor.
- c. All costs necessary or incidental for handling and administrative charges and for any materials and/or permits required for installation of the replacement heater or part.

LIMITATION ON IMPLIED WARRANTIES

Implied warranties, including any warranty of merchantability imposed on the sale of this heater under state law are limited to one year duration for the heater or any of its parts. Some states do not allow limitations on how long an implied warranty lasts, so the above limitations may not apply to you.

CLAIMS PROCEDURE

Any claim under this warranty should be initiated with the distributor, dealer, or seller who sold the heater, or with any other dealer handling the warrantor's products. If this is not practical, the owner should contact: Infrared Dynamics, 3830 Prospect Avenue, Yorba Linda, California 92886. Phone 1-888-317-5255 or visit our website: www.infradyne.com.