



**Model U412/SU412**  
**SERVICE MANUAL**

Manual No. [513630](#)

V5



# Service Manual

## SAFETY INFORMATION

This manual provides basic information about the safety, operation, and service of the machine. This manual follows the guidance set forth in the following industry standards: ANSI Z535.6, ASTM F760-93, ASTM F1827-13, and the FDA Food Code.

The illustrations and specifications in this manual are not binding in detail. Stoelting Foodservice Equipment reserves the right to make changes to the machine without notice, and without incurring any obligation to modify or provide new parts for machines built prior to date of change.

**DO NOT ATTEMPT to operate the machine until all instructions and safety precautions in this manual are read completely and are thoroughly understood. The installation and startup of this machine must be performed by a qualified technician. The warranty will be void if the machine is not installed correctly.** For problems or questions with installation, operation, or servicing, contact Stoelting White Glove Service — 1.800.319.9549.

### **WARNING**

“WARNING” indicates a potential hazard that can or will cause severe injury or death if not avoided.

### **CAUTION**

“CAUTION” indicates a potential hazard that can cause minor or major injury if ignored.

“NOTICE” indicates equipment/property damage information. It is not hazard-related.

“NOTE” indicates additional information, usually a hint or tip, that is not hazard-related and does not involve equipment/property damage.

If you need to replace a part, use genuine Stoelting parts with the correct part number when possible. We strongly recommend that you do not use replacement parts of inferior quality.

For warranty information, visit [www.stoeltingfoodservice.com](http://www.stoeltingfoodservice.com).

# TABLE OF CONTENTS

<b>Section</b>	<b>Description</b>	<b>Page</b>
<b>1</b>	<b>Description &amp; Specifications</b>	
1.1	Description.....	1
1.2	Specifications .....	2
1.3	Modes of Normal Operation .....	3
1.4	Mix Level Indicators.....	5
1.5	Storage Refrigeration .....	5
1.6	Operation During Sensor Failure.....	5
1.7	Motor Profile Cutout Compensation .....	5
1.8	IntelliTec™ Control Setting Specifications .....	6
<b>2</b>	<b>Maintenance &amp; Adjustments</b>	
2.1	Freezer Adjustment .....	7
2.2	Product Consistency Adjustment.....	7
2.3	Locking the Control Panel .....	7
2.4	Obtaining Readings & Modifying Settings (Service Personnel Only) .....	7
2.5	Readings (Service Personnel Only) .....	8
2.6	Adjustments (Service Personnel Only).....	9
2.7	Other Settings (Service Personnel Only).....	9
2.8	Overrun Adjustment.....	10
2.9	Mix Pump Hose Reposition .....	11
2.10	Mix Pump Hose Replacement .....	11
2.11	Cab Temperature Adjustment .....	12
2.12	Drive Belt Tension Adjustment.....	12
2.13	Condenser Cleaning (Air-Cooled Freezers) .....	13
2.14	Preventive Maintenance .....	13
2.15	Extended Storage.....	13
<b>3</b>	<b>Refrigeration System</b>	
3.1	Refrigeration System .....	15
3.2	Refrigerant Recovery & Evacuation .....	15
3.3	Refrigerant Charging .....	16
3.4	Compressor .....	17
3.5	Condenser .....	18
3.6	Evaporator .....	18
3.7	Valves .....	18
A.	Thermostatic Expansion Valve (TXV) .....	18
B.	Check Valve .....	19
C.	High Pressure Cutout.....	19
D.	Hot Gas Bypass .....	20
E.	Evaporator Pressure Regulator (EPR).....	21
F.	Water Valve (Water Cooled Models Only).....	21
3.8	Solenoid.....	22

Section	Description	Page
3.9	Filter Drier.....	23
3.10	Capillary Tube.....	24
3.11	Cab Unit.....	24
<b>4</b>	<b>Electrical &amp; Mechanical Control Systems</b>	
4.1	IntelliTec™ Controller.....	25
4.2	Contactors.....	25
4.3	Drive Motor.....	26
4.4	Capacitors.....	26
4.5	Gearbox.....	27
4.6	Condenser Fan Motor (Air-Cooled Only).....	28
4.7	Cab Condenser Fan Motor.....	28
4.8	Switches.....	29
A.	Spigot Switch.....	29
B.	Blender Activation Switch.....	30
C.	Pump Pressure Switch.....	30
4.9	Potential Relay.....	31
4.10	Temperature Control Sensor.....	31
4.11	Spinner Speed Control Harness.....	31
<b>5</b>	<b>Troubleshooting</b>	
5.1	Error Codes.....	33
5.2	Troubleshooting - Error Codes.....	33
5.3	Troubleshooting - Machine.....	36
5.4	Troubleshooting - Mix Pump.....	37
<b>6</b>	<b>Replacement Parts</b>	
6.1	Auger & Front Door Parts.....	39
6.2	Blender Parts & Trays.....	40
6.3	Cab Tubing Assembly.....	41
6.4	Spigot Cam Assembly.....	42
6.5	Front Panel.....	43
6.6	Part Kits.....	43
6.7	Pump Parts.....	44
6.8	Cab Interior.....	46
6.9	Header Panel - Electrical.....	47
6.10	Left Hand Side.....	48
6.11	Right Hand Side.....	49
6.12	Rear.....	50
6.13	Brushes, Decals & Lubrication.....	51
6.14	Stainless Steel Panels.....	51
6.15	Refrigeration & Wiring Diagrams.....	52

# SECTION 1 DESCRIPTION & SPECIFICATIONS

## 1.1 DESCRIPTION

The U412 and SU412 are ultra high capacity floor model shake machines. They are equipped with fully automatic controls to provide a uniform product. This manual is designed to assist qualified service personnel and operators with installation, operation and maintenance of the U412 and SU412 machines.



Figure 1-1 Model SU412 Machine

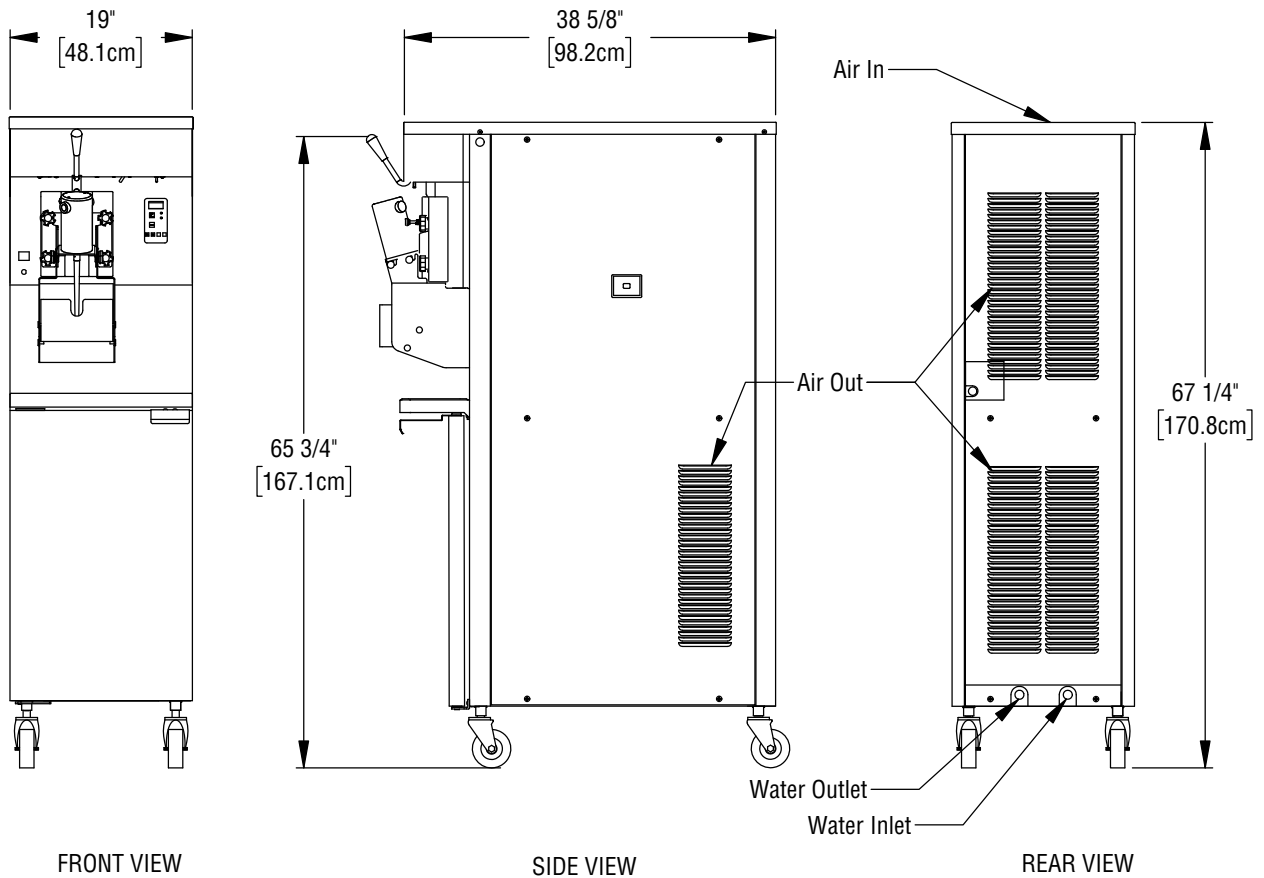

Figure 1-2 Machine Dimensions

## 1.2 SPECIFICATIONS

Models U412 & SU412		
Dimensions	Machine	with crate
width	19" (48,3 cm)	27" (68,6 cm)
height	67-1/4" (170,8 cm)	78" (198,1 cm)
depth	38-5/8" (98,1 cm)	48" (121,9 cm)
<b>Weight</b>	450 lbs (204,1 kg)	550 lbs (249,4 kg)
<b>Electrical</b>	<b>1 Phase, 208-240 VAC, 60Hz</b>	
circuit ampacity	18A minimum (U412), 19A minimum (SU412)	
overcurrent protection device	30A maximum	
<b>Compressor</b>	11,000 Btu/hr Scroll™ Compressor	
<b>Drive Motor</b>	3/4 hp	
<b>Air Flow</b>	Air cooled units require 3" (7,6 cm) air space on both sides, 6" back.	
<b>Plumbing Fittings</b>	Water cooled units require 1/2" N.P.T. water and drain fittings. Maximum water pressure of 130 psi. Minimum water flow rate of 3 GPM. Ideal EWT of 50°-70°F	
<b>Hopper Volume</b>	8 gallons (30,29 liters)	
<b>Freezing Cylinder Volume</b>	2.1 gallon (7,95 liters)	

	Serial Number Date Codes 'T' & Later	Serial Number Date Codes 'S' & Earlier
<b>Refrigerant</b>	R-448A*	R-404A*
<b>Charge</b>	A/C 34 oz W/C 26 oz	A/C 32 oz W/C 24 oz
<b>Suction Pressure (at 72°F)</b>	24-26 psig	25-27 psig
<b>Discharge Pressure</b>	215-240 psig	210-235 psig
<b>Cab Pressure (only cab running)</b>	18 psig (maintained by the bypass valve)	18 psig (maintained by the bypass valve)
<b>EPR Valve</b>	78-80 psig	78-80 psig

\* Refer to the machine's nameplate to confirm refrigerant

### 1.3 MODES OF NORMAL OPERATION

Following are details of the operational modes on the U412 and SU412.

**NOTE:**

*Preset amounts, times, and temperatures listed below describe actual settings on the IntelliTec™ control. Refer to Table 1-1 on page 6 for details on each setting.*

#### A. INITIAL STATUS

When the Main Freezer Power and Freezing Cylinder switches are placed in the ON position, the machine will start in the “Sleep 1 Mode”. The display will read “Sleep 1 Mode”. The control will eventually move into the “Sleep 2” mode if the PUSH TO FREEZE button is not pressed. When the PUSH TO FREEZE button is pressed the control will move to the “Serve Mode”.

#### B. SERVE MODE

When the PUSH TO FREEZE button is pressed or a spigot handle is pulled, the “Serve Mode” begins. The drive motor starts, and after a 3 second delay, the compressor starts. The display reads “FREEZING” on the top line and a bar on the bottom line increases with product consistency. A toroid on the IntelliTec™ control senses increasing drive motor amperage as the product comes to consistency in the freezing cylinder. When the control senses the product is at 75% of consistency, the display will read “SERVE”, the amber LED will go out and the green LED will blink. At this time, product can be served from the machine. The drive motor and compressor will continue to run until the toroid reads a preset value (CutOut amps). When the toroid reads the CutOut amps on the drive motor, the compressor turns off. After a 3 second delay, the drive motor turns off. The product in the freezing cylinder is now at serving temperature and consistency and the green LED will remain lit.

After product is at consistency, the IntelliTec™ control continuously monitors refrigerant temperature through a thermistor mounted on the side of the freezing cylinder. When the temperature increases to a preset amount (Cut In T), a 3-second drive motor pre-stir analyzes product consistency. The pre-stir check is also performed each time the spigot handle is opened. This check prevents over-freezing of product, especially during frequent, small volume draws. If product requires a freezing cycle, the control will start the cycle.

During the “Serve Mode”, a stir cycle starts. This cycle is independent of the freezing cycle and is based on preset times (Stir On and Stir Off). The stir cycle prevents product separation. If a freezing cycle is initiated, the timer is reset.

In addition to the “Serve Mode” freezing cycle, there is a freezing cycle based on a preset time (DftOffTime). If this time is attained without a freezing cycle, the control will automatically start a freezing cycle. If a freezing cycle is initiated, the timer is reset.

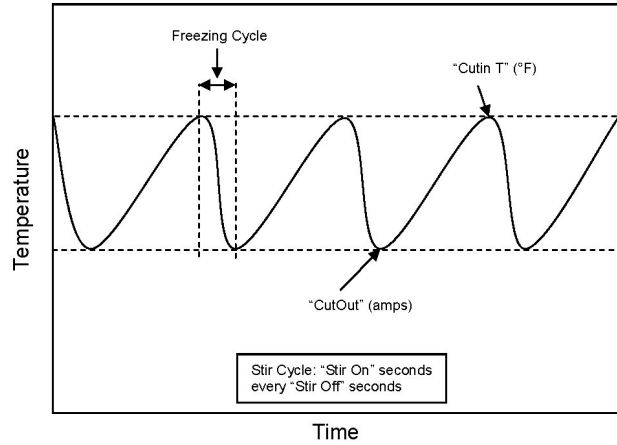

**Figure 1-3 Serve Mode**

The machine will remain in “Serve Mode” until the cycle count setting is attained. The cycle count is the number of active freezing cycles and is based on a preset value (Cycles). Once the cycle count has been reached without user interruption, the control will move into the “Standby Mode”.

If the PUSH TO FREEZE button is pressed or a spigot handle is pulled, the cycle count is reset and the control will move to the beginning of the “Serve Mode”. Refer to Figure 1-3 for a graphical representation of the “Serve Mode”.

#### C. STANDBY MODE

If product has not been drawn from the spigot and the preset number of active freezing cycles is met, the control moves into the “Standby Mode”. In “Standby Mode”, the freezing cycle is based on preset timers (On Time and Off Time), and prevents ice crystals from building up in the product. Because the product remains partially frozen, it can quickly return to servable consistency when the PUSH TO FREEZE button is pressed.

During “Standby Mode”, the stir cycle runs. This cycle is based on preset, timed intervals (Stir On and Stir Off) and prevents product separation.

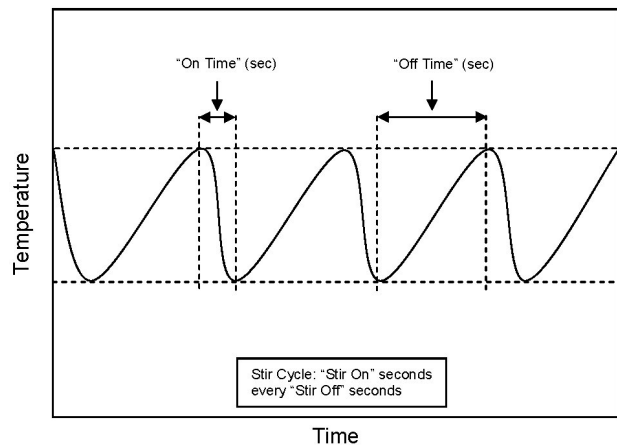

**Figure 1-4 Standby Mode**

The “Standby Mode” maintains product quality during slow times, while minimizing reactivation time. This mode lasts for a preset time (Stb Time). Once this time has been reached without user interruption, the control moves into the “Sleep 1 Mode”. Refer to Figure 1-4 for a graphical representation of the “Standby Mode”.

If a spigot is opened or the PUSH TO FREEZE button is pressed, the control will move to “Serve Mode”. Product in the front of the freezing cylinders may or may not be at consistency. The state of the product is dependent on a number of variables but will come to consistency quickly.

#### D. SLEEP 1 MODE

After the “Standby Mode” time has expired without user interruption, the control will move into the “Sleep 1 Mode”. During the “Sleep 1 Mode”, the stir cycle is handled by preset timers (SI1DrvOn and SI1DrOff), and allows product to melt to a liquid state by using agitation cycles without any flow of refrigerant. Although the product temperature never increases above 41°F, the product thaws rapidly which minimizes product breakdown. The control will stay in the “Sleep 1 Mode” until sensing a preset temperature (SI2CutIn). When this temperature has been reached without user interruption, the control will move to the “Sleep 2 Mode”. Refer to Figure 1-5 for a graphical representation of the “Sleep 1 Mode”.

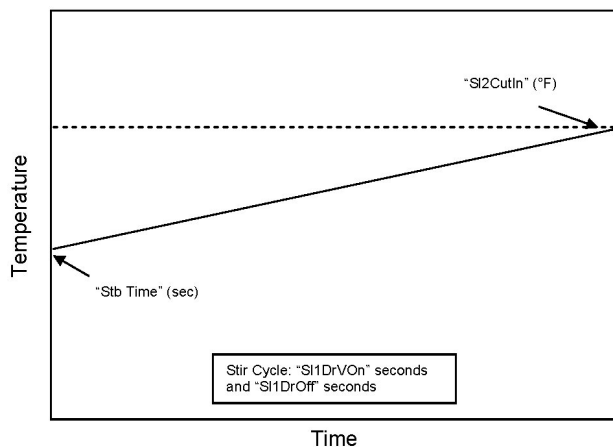
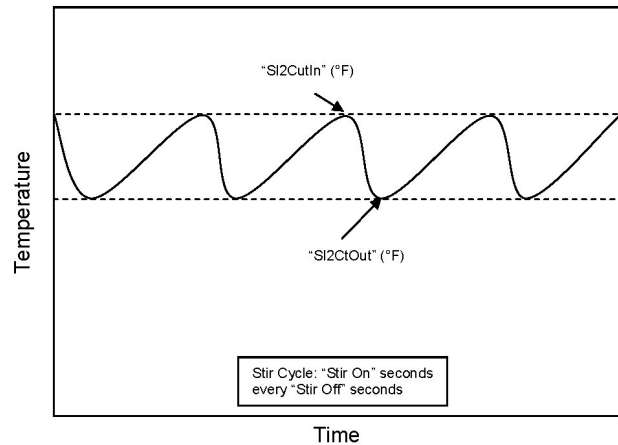

**Figure 1-5 Sleep 1 Mode**

If a spigot is opened or the PUSH TO FREEZE button is pressed, the control will move to “Serve Mode”. If the spigot is opened in “Sleep 1 Mode”, the product will not be at consistency. The operator must wait until the first “Serve Mode” freezing cycle has completed to serve product.

#### E. SLEEP 2 MODE

The “Sleep 2 Mode” maintains the freezing cylinder temperature between two preset values (SI2CutIn and SI2CtOut). During the “Sleep 2 Mode”, the stir cycle runs. This cycle is based on preset, timed intervals (Stir On and Stir Off) and prevents product separation. The “Sleep 2 Mode” is often referred to by customers as the “night mode” and the machine will stay in this mode until a spigot is opened or the PUSH TO FREEZE button is



**Figure 1-6 Sleep 2 Mode**

pressed. When this occurs, the control will move to “Serve Mode”. If the spigot is opened at this time, the product will be liquid. The operator must wait until the first “Serve Mode” freezing cycle has completed to serve product. Refer to Figure 1-6 for a graphical representation of the “Sleep 2 Mode”.

#### F. INTELLITEC™ RESTART

If a hard error occurs (refer the hard error list below), the IntelliTec™ control will wait 5 minutes then attempt to clear the error by restarting itself. The control will count each restart attempt. The restart count will reset if the PUSH TO FREEZE button is pressed, the spigot is pulled, or the Freezing Cylinder OFF/ON switch is placed in the OFF position.

The following are considered hard errors:

##### ERROR CODE MALFUNCTION

- 2 High Torque
- 3 Run Time
- 4 Clean
- 7 Drive Motor
- 9 High Pressure Cutout

When a restart occurs, the second line of the display will read “Restart” and the backlight will blink. This will occur regardless of the system mode.

#### G. SLEEP 3 MODE

If a high torque, run time, or drive motor error condition occurs on the third restart attempt, the control will move to the “Sleep 3 Mode”.

In “Sleep 3 Mode” freezing cylinder refrigeration will run for 4 seconds every 10 minutes. This ensures the product temperature never increases above 40°F. The stir cycle and the auger do not run during “Sleep 3 Mode”.

The control will exit “Sleep 3 Mode” if the PUSH TO FREEZE button is pressed, the spigot is pulled, or the Freezing Cylinder OFF/ON switch is placed in the OFF position.

## H. CLEAN MODE

When the CLEAN button is pressed, freezing cylinder refrigeration stops, the drive motor starts and will run for 20 minutes and a 5 minute countdown timer is displayed. After the time has elapsed, an optional audible alarm will sound if this accessory has been installed. The audible alarm is a reminder for the operator to end the “Clean Mode” when cleaning is completed.

If the machine is kept in “Clean Mode” for more than 20 minutes, the auger drive motor stops, and an error code (E4) is displayed on the display panel. The error code prevents damage to the machine that could occur during an extended clean mode (Refer to Section 8 - Troubleshooting for details). To clear this error, place the Freezing Cylinder Off-On switch in the Off position and back in the On position. If the machine is still being cleaned, pushing the CLEAN button will reset the timer and restart the “Clean Mode”.

### 1.4 MIX LEVEL INDICATORS

The cabinet is equipped with a capacitive sensor to monitor mix level. When the mix level drops below the sensor limit, the lower line of the display will read “Low Mix” and the display will flash. To clear the “Low Mix” error, add mix to the cabinet’s mix container.

### 1.5 STORAGE REFRIGERATION

The IntelliTec™ control is programmed to handle refrigeration of the cabinet independently from the freezing cylinder. The control maintains cabinet temperature between two preset values (CabCutIn and CabCtOut). The cabinet will operate automatically unless one of the following conditions are met:

If the Main Power switch is in the OFF position the Cab Off light on the front of the machine will flash.

If the cabinet door is opened during a refrigeration cycle, the evaporator fan will continue to run but the refrigeration cycle will be interrupted to prevent the evaporator coils from icing up.

If there is a High Pressure Cutout Error (E9) all the refrigeration stops.

#### NOTE

*If the temperature in the cabinet stays above 50°F for more than two hours, the machine will go into Sleep Mode and a clean message will be shown on the display.*

### 1.6 OPERATION DURING SENSOR FAILURE

The IntelliTec™ control is designed to allow the machine to continue to function if a temperature sensor failure occurs. If a sensor fails, the display will show the error and the control will run the machine on timers for the freezing

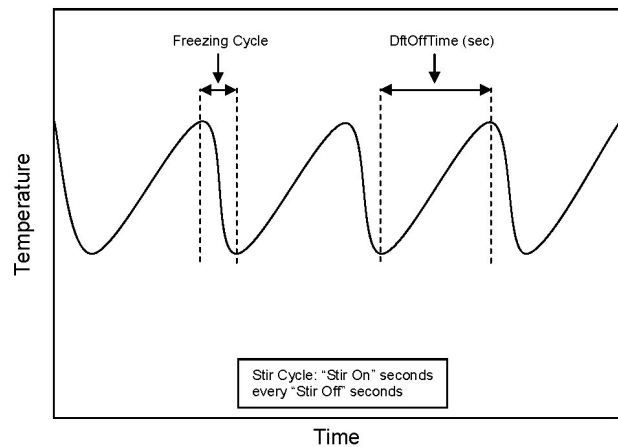

Figure 1-7 Serve Mode (Sensor Failure)

cycle or cabinet refrigeration. This allows the operator to continue to serve product from the machine until proper servicing can be completed.

### A. SERVE & STANDBY MODE

In the event of a temperature sensor failure on a freezing cylinder, the IntelliTec™ control will function in two modes, “Serve Mode” and “Standby Mode”. When the product is at consistency in “Serve Mode”, the IntelliTec™ control uses a timer instead of the sensor and will not start another freezing cycle until a preset value (DtOffTm) is met.

The control will monitor product after it is at consistency, activating the stir cycle and counting the number of cycles. When the cycle count is reached, the control will move to “Standby Mode”.

The “Standby Mode” is the same as in normal operation with the exception of when the preset time (Stb Time) is met, the control moves back into the “Serve Mode”. Refer to Figure 1-7 for details.

### B. CABINET REFRIGERATION

In the event of a temperature sensor failure in the cabinet, the cabinet refrigeration cycle is managed by preset times (Cab On and Cab Off). This refrigeration cycle is independent of the freezing cylinder refrigeration and the cycle restarts if the cabinet door is opened.

### 1.7 MOTOR PROFILE CUTOUT COMPENSATION

The IntelliTec™ control is programmed to automatically function at a range of supply voltages. This feature provides the advantage of having product maintained at a specific temperature and consistency irrespective of the supply voltage. A motor profile curve is programmed on the IntelliTec™ control and provides a relationship between the supply voltage and drive motor cutout amperage. Depending on the supply voltage, the control varies cutout amperage according to the motor profile. This feature is automatic and does not need any configuring.

# IntelliTec™ Control Setting Specifications

Basic Menu	DISPLAY	Value	MODE	DEFINITION
	CutOut	*	Serve	Amp draw setting for cut out
	Cut In T	26.5°F	Serve	Temperature setting for cut in
	Cycles	20	Serve	Freezing cycles before going into Standby Mode
	Stir On	15 sec	Serve	Stir-only on time
	Stir Off	300 sec	Serve	Stir-only off time

Advanced Menu	DISPLAY	Value	MODE	DEFINITION
	On Time	28 sec	Standby	Freezing cycle “on” time (runs on timers only)
	Off Time	450 sec	Standby	Freezing cycle “off” time
	Stb Time	120 sec	Standby	Total time in mode
	SI1DrvOn	120 sec	Sleep 1	Drive motor “on” timer
	SI1DrOff	180 sec	Sleep 1	Drive motor “off” timer
	SI2CutIn	37°F	Sleep 2	Cut in temperature
	SI2CtOut	31°F	Sleep 2	Cut out temperature
DftOffTm	900 sec	No Sensor	Default “off” time. Used in case of sensor failure	

Storage Menu	DISPLAY	Value	MODE	DEFINITION
	Refriger	Cabinet	All	Set to None, 1 Hopper, 2 Hopper, or Cabinet
	CabCutIn	38°F	All	Refrigerated cab cut in temperature
	CabCtOut	34°F	All	Refrigerated cab cut out temperature
	Cab Off	13 sec	No Sensor	Default “off” time. Used in case of sensor failure
Cab On	130 sec	No Sensor	Default “on” time. Used in case of sensor failure	

\* The CutOut value needs to be adjusted to product requirements. Refer to the 2183775 - Specification Sheet for SU412 Control located in the plastic pouch behind the header panel.

**Table 1-1 IntelliTec Control Setting Specifications**

## SECTION 2 MAINTENANCE & ADJUSTMENTS

### 2.1 FREEZER ADJUSTMENT

This section is intended to provide maintenance personnel with a general understanding of the freezer adjustments. It is recommended that any adjustments in this section be made by a qualified person.

### 2.2 PRODUCT CONSISTENCY ADJUSTMENT

The operator can adjust product consistency by modifying the Fine Adjustment setting on the membrane switch. This is the only adjustment that can be made by the operator without using a pass code key sequence. Product consistency fine adjustment allows a 0.4 amp maximum adjustment to the drive motor amp draw cutout. Increasing this setting will increase the drive motor amperage cutout and increase product consistency. Follow the instructions below to make fine adjustments to product consistency.

- A. Place the Main Freezer Power switch in the ON position.
- B. Press the SET button on the Control Panel once. Fine Adj will appear on the LCD screen.
- C. Press the up arrow button (↑) until the desired consistency setting is displayed. The higher the number, the firmer the product consistency. The control may be set from 1 to 9. The value increases by 1 each time the up arrow button is pressed. After the value reaches 9, numbering restarts at 0. The 0 setting cannot be set.
- D. Press the SET button once to save the setting and return to the current mode display.

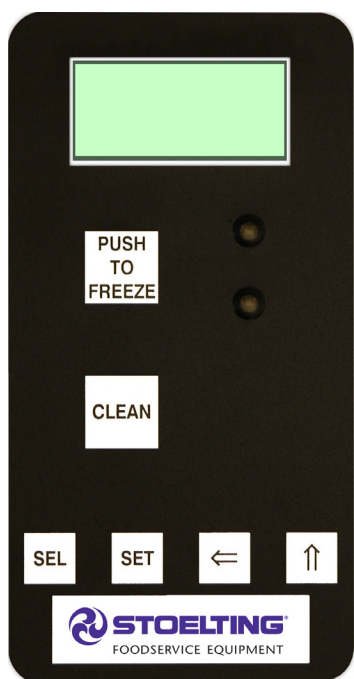

Figure 2-1 Membrane Switch

### 2.3 LOCKING THE CONTROL PANEL

The IntelliTec™ control has a tamper proof mode to prevent unauthorized use. When set, all buttons on the control panel are disabled. Follow the instructions below to lock the control panel

- A. Press and hold the PUSH TO FREEZE button for at least 5 seconds.
- B. While still holding the PUSH TO FREEZE button, press the CLEAN button once.
- C. Release both buttons. An asterisk (\*) will appear on the bottom line of the display, indicating that the control is in the lock out mode.

#### NOTE:

*Repeat steps A, B, and C to unlock the control panel.*

### 2.4 OBTAINING READINGS & MODIFYING SETTINGS (SERVICE PERSONNEL ONLY)

Readings and settings on the IntelliTec control are accessed through the IntelliTec control menu settings. Locating freezer readings and system function settings are done using the up arrow (↑) and left arrow (←) buttons on the membrane switch. A printed IntelliTec™ Menu Settings sheet is located in the information pouch behind the header panel.

#### IntelliTec Control Readings

To obtain freezer readings, locate the value on the freezer's menu settings sheet and follow the steps below.

- A. Press and hold the SEL button for 8 seconds. While still holding the SEL button, press the up arrow button (↑). The LCD screen will read DISPLAY.
- B. Release both buttons.
- C. Press the up arrow button (↑) to navigate to the correct reading under DISPLAY or press the left arrow (←) button to navigate to the ERRCODES menu.
- D. Press the up arrow (↑) and left arrow (←) buttons to navigate through the rest of the readings as needed.
- E. When all readings have been obtained, press the up arrow button (↑) from ExitMenu to return to the current mode display.

#### Modifying Control Settings

To change the value of a system function, locate the function on the IntelliTec Settings Menu and follow the steps below.

## IMPORTANT:

*Before making changes to any settings, record the original values. If the setting changes do not achieve desired results, return settings to their original values.*

- A. Press and hold the SEL button for 8 seconds. While still holding the SEL button, press the up arrow button (↑). The LCD Screen will read DISPLAY.
- B. Release both buttons.
- C. Press the left arrow button (←) to get to the correct menu (Basic, Advanced, or Storage).
- D. Press the up arrow button (↑) to navigate to the value that needs to be changed.
- E. Press the SET button to enter the edit mode.
- F. Press the up arrow button (↑) to change the setting.
- G. Press the SET button to save the setting and exit the edit mode.
- H. Press the up arrow (↑) and the left arrow (←) buttons to navigate through the rest of the settings as needed.
- I. When all changes have been completed, press the up arrow button (↑) from ExitMenu to return to the current mode display.

## 2.5 READINGS (SERVICE PERSONNEL ONLY)

The IntelliTec™ control continuously monitors and records temperatures, voltages, amps, and error code details. Each reading is beneficial to service personnel when troubleshooting.

### DISPLAY READINGS

Following are the readings available under the DISPLAY menu:

#### Cabinet

The temperature of the cab is constantly monitored by the IntelliTec control.

#### Cycles (count)

This reading counts down the number of cycles in the current "Serve Mode". The starting value is dependent upon the Cycles setting on the IntelliTec control.

#### °F and amps

Suction line temperature on the freezing cylinder and drive motor amps are available on the same screen to assist with setup and troubleshooting.

#### Aux. Temp (°F)

This reading provides the ambient temperature around the IntelliTec control board.

#### Supply V (VAC)

A calculated input voltage is recorded.

### ERROR CODE READINGS

The following details are recorded under the ERRCODES menu for each of the last 25 error codes received:

#### Err1 (hours)

A numerical count of the last 25 error codes is recorded. When the 26th error has occurred, the earliest error code is erased. A timer also begins when an error occurs. The timer records the number of hours since the error occurred. If power to the freezer is interrupted, the timer will stop until power has been restored.

#### °F and amps

The suction gas temperature on the freezing cylinder and the drive motor amps are recorded at the time of the error.

#### Aux. Temp (°F)

Ambient temperature of the IntelliTec control board is recorded at the time of the error.

#### Str (°F)

The storage temperature is recorded at the time of the error.

#### VAC and Mode

A calculated input voltage and mode at which the error occurred are recorded. Following are descriptions of each mode:

Mode	Description
0	Start of freezing cycle
1	Compressor and drive motor on
2	Stir Cycle
3	Compressor off
4	"Standby Mode"
5	"Sleep 1 Mode"
6	"Sleep 2 Mode"
7	"Clean Mode"
8	Startup
9	Storage only refrigeration
10	Freezing cycle is shut down
11	Door safety switch triggered
12	High pressure cutout

#### Up Time (hours)

This value is a record of the total time the freezer has been in service. If power is interrupted, the timer will stop until power is restored. This timer does not reset.

## RUN STATISTICS

In addition to dynamic readings and recorded error code details, the IntelliTec™ control records rolling averages of run statistics. Following are the readings available under the RUNSTATS menu:

### On Times (sec)

The control records the time of each freezing cycle and provides a rolling average.

### Off Times (sec)

The control records the time between freezing cycles and provides a rolling average.

### Brl. Min (°F)

The lowest average barrel temperature is recorded.

### Brl. Max (°F)

The highest average barrel temperature is recorded.

### Stor Min (°F)

The lowest average cabinet temperature is recorded.

### Stor Max (°F)

The highest average cabinet temperature is recorded.

### Power On (hrs)

This value is a record of the time the freezer has been in service. If power is interrupted, the timer will reset.

## 2.6 ADJUSTMENTS (SERVICE PERSONNEL ONLY)

The following adjustments directly affect product consistency and length of time in “Serve Mode”. The default settings have been created using a 5% milkfat soft serve mix and provide optimal product consistency while prolonging product life.

### CutOut (amps)

It is recommended to set the CutOut value at initial startup and when changing mix types. Adjustments to this setting directly affect the length of the freezing cycle which changes product consistency. To properly set the CutOut value, refer to section 3-10.

### Cut In T (°F)

After the consistency value has been determined, the Cut In T value can be adjusted. The Cut In T is the temperature of the refrigerant gas in the evaporator at the front of the freezing cylinder. Changing this setting changes the temperature at which the freezing cycle starts. This value along with the CutOut value determines the range of temperatures (or “temperature window”) of the product. Decreasing the temperature decreases the temperature window and, under normal use, increases the amount of freezing cycles. This creates a greater chance of product breakdown by stirring the product often. Increasing the Cut In T increases the temperature window, which decreases freezing cycles and increases the chance of heat shock within the product.

### Cycles (count)

This setting determines the number of freezing cycles during “Serve Mode”. Increasing the value will increase the total time in “Serve Mode”. Factory default is 20 cycles, which results in “Serve Mode” lasting about 2-1/2 hours without the PUSH TO FREEZE button being pressed or a spigot handle being pulled. If the PUSH TO FREEZE button is pressed or the spigot handle is pulled at any time during “Serve Mode”, the Cycles count will reset.

## 2.7 OTHER SETTINGS (SERVICE PERSONNEL ONLY)

Changing any setting on the IntelliTec control will alter freezer operation and affect the product temperature, consistency, or life. Refer to the IntelliTec Control System Settings sheet located in the information pouch behind the header panel of the freezer. If any of the following settings on the IntelliTec control differ from the System Settings sheet, it is recommended to return those settings to factory defaults.

### Stir On (sec)

Adjustments to this setting affect the amount of time the auger rotates in the stir cycle. The stir cycle occurs in “Serve Mode”, “Standby Mode”, and “Sleep 2 Mode”.

### Stir Off (sec)

Adjustments to this setting affect the time between stir cycles. The stir cycle occurs in “Serve Mode”, “Standby Mode”, and “Sleep 2 Mode”.

### On Time (sec)

Increasing this value will increase the length of the freezing cycle during “Standby Mode”.

**Off Time (sec)**

Increasing this value will increase the time between freezing cycles in “Standby Mode” and result in an increase of product temperature in the barrel.

**Stb Time (sec)**

This setting determines the total amount of time in “Standby Mode”.

**SI1DrvOn (sec)**

Adjustments to this setting affect the amount of time the auger rotates in the stir cycle. This stir cycle only occurs in “Sleep 1 Mode”.

**SI1DrOff (sec)**

Adjustments to this setting affect the time between stir cycles. The stir cycle only occurs in “Sleep 1 Mode”.

**SI2CutIn (°F)**

Changing this setting affects the temperature at which the freezing cycle starts in “Sleep 2 Mode”.

**SI2CtOut (°F)**

Changing this setting affects the temperature at which the freezing cycle stops in “Sleep 2 Mode”.

**DftOffTm (sec)**

In “Serve Mode”, this value determines the maximum time without a freezing cycle. If this value is met, a freezing cycle will start. In the event of a freezing cylinder temperature sensor failure, this value affects the amount of time between freezing cycles during “Serve Mode”.

**Refriger**

This setting changes how the control handles the storage refrigeration cycle. The setting for the SU412 is Cabinet.

**CabCutIn (°F)**

If Refriger value is set to Cabinet, this determines the temperature at which the refrigeration cycle starts. If None, 1 Hopper, or 2 Hopper is selected for the Refriger setting, CabCutIn will not be shown on the IntelliTec™ menu.

**CabCtOut (°F)**

If Refriger value is set to Cabinet, this determines the temperature at which the refrigeration cycle stops. If None, 1 Hopper, or 2 Hopper is selected for the Refriger setting, CabCtOut will not be shown on the IntelliTec menu.

**Cab Off**

If the Refriger value is set to Cabinet and the temperature sensor in the cabinet fails, this setting determines the time between refrigeration cycles. If None, 1 Hopper, or 2 Hopper is selected for the Refriger setting, Cab Off will not be shown on the IntelliTec menu.

**Cab On**

If the Refriger value is set to Cabinet and the temperature sensor in the cabinet fails, this setting determines the length of the refrigeration cycle. If None, 1 Hopper, or 2 Hopper is selected for the Refriger setting, Cab On will not be shown on the IntelliTec menu.

**2.8 OVERRUN ADJUSTMENT**

The product, when served, is a combination of air and mix. Overrun is a measure of the amount of air blended into the mix.

Overrun can be expressed in terms of the amount of weight loss for a given volume. For example, if a pint of liquid mix weighs 18 ounces and a pint of frozen product with air added weighs 12 ounces, the overrun is said to be 50 percent:  $18 \text{ oz.} - 12 \text{ oz.} = 6 \text{ oz.}, (6/12) \times 100 = 50\%$

The overrun can be checked by placing a one pint container on an ice cream scale and zeroing out the scale. Then fill a one pint container with frozen product. The container should be filled over the top and leveled with a straightedge. The product should not contain any air pockets. When weighed on an ice cream scale, one pint of product should weigh 12 to 13 ounces.

The mix pump has been preset at the factory to produce a product with approximately 40% overrun. Because of differences in mix formulation, temperatures and barometric pressure, this figure may vary. It will be necessary for approximately 2 gallons of mix to be pumped through the freezer before overrun changes in the product are noticeable.

Overrun is controlled by the length of the air compressor piston stroke within the piston cylinder. Lengthening the stroke within the cylinder will increase overrun. Conversely, shortening the stroke will decrease overrun. To perform an overrun adjustment, refer to the following procedure:

**WARNING****Hazardous voltage**

The Main Freezer Power switch must be placed in the OFF position when disassembling for servicing. The freezer must be disconnected from electrical supply before removing any access panel. Failure to disconnect power before servicing could result in death or serious injury.

- A. Turn the mix pump switch to the OFF position. Disconnect power sources/circuit breakers.
- B. Remove the back panel from the freezer.
- C. On the air compressor side of the pump, locate the long/slender piston rocking arm. The rocking arm downward travel is limited by a stationary cam. On the face of the cam there is an overrun setting indicator plate numbered 3 through 8 and an adjustment knob (Fig. 2-2).
- D. The overrun setting is indicated by a pin.

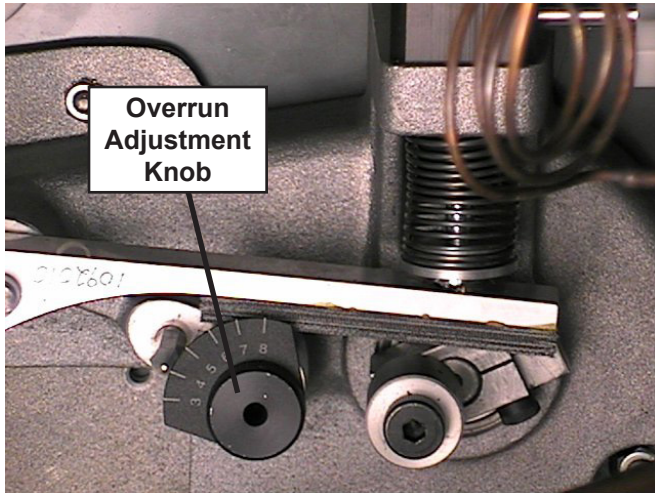

**Figure 2-2 Overrun Adjustment**

- E. To adjust overrun, loosen the allen-head screw (located within the center of the adjustment knob) with the 5/32" allen wrench provided. Rotate the adjustment knob counterclockwise to a higher number for higher overrun, or clockwise to a lower number for lower overrun. Each number multiplied by 10 represents the overrun percentage (i.e. setting 4 = 40% overrun).
- F. Tighten the allen screw, then place the wrench back in its clip. Replace the lower back panel and secure with the four screws. Turn the mix pump power switch to the ON position.

## 2.9 MIX PUMP HOSE REPOSITION

Mix pump hose must be repositioned every 800 gallons of mix pumped or every 2 weeks. Failure to reposition the hose will result in reduced mix pump liquid capacity, dispense stoppage, popping, and possible mix pump hose leakage. Follow the steps below to reposition the hose:

- A. Run cleaning solution through pump.
- B. Turn the pump off and relieve any pressure by opening the spigot.
- C. Grasp the pickup hose end of the mix pump hose with one hand and turn the pump on. Pull down on the pickup hose end until 12 to 14 inches of tubing has fed through the pump then turn the pump off (Fig. 2-3).

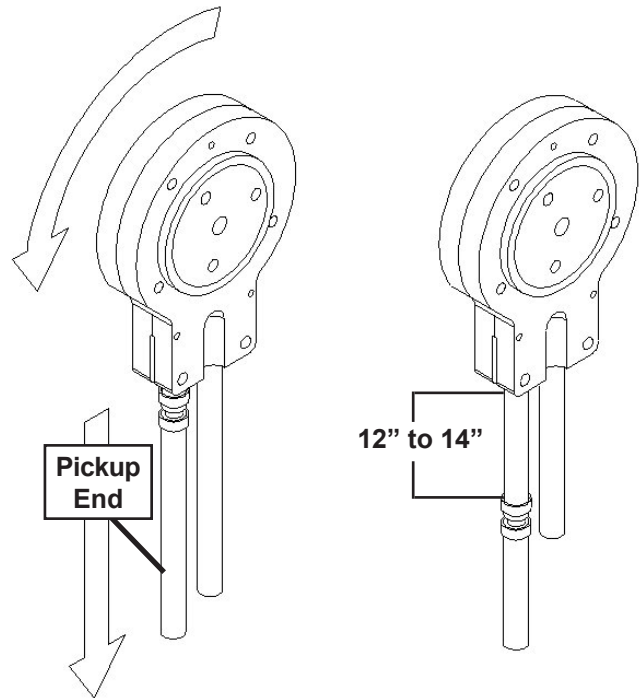

**Figure 2-3 Pump Hose Reposition**

- D. Loosen the small clamp at the pick-up hose adapter and disconnect the mix pump hose.
- E. Cut 7-1/2 inches off the end of the mix pump hose.
- F. Reconnect the mix pump hose to the adapter.
- G. Continue normal operation. Mix hose will automatically reposition itself with the adapter near the black cover.

### NOTE

*Each hose is long enough for 3 repositions before replacement is required.*

## 2.10 MIX PUMP HOSE REPLACEMENT

Mix pump hose must be replaced when tubing cannot be further repositioned (every four to eight weeks). Failure to comply will result in hose failure and possible pump damage. Follow the steps below to replace the hose:

- A. Run cleaning solution through pump.
- B. Turn the pump off and relieve any pressure by opening the spigot.
- C. Disconnect the mix pump hose at each end.
- D. Grasp the discharge hose end with one hand and turn the pump on. Pull down on the hose until all of the remaining hose is removed from the pump. Turn pump off.
- E. Rotate pump roller assembly so one roller is at the 6:00 position.
- F. Use a brush that fits in the opening and clean the pump roller assembly, first with detergent water and then clear water.

- G. Connect the new mix pump hose to the pickup hose adapter using the small clamp.
- H. Feed one end of the mix pump hose into the pickup hose side (left) of the black cover.
- D. Press the up arrow button (↑) once to navigate to the CabCutIn value. Record this value.

**IMPORTANT**

*Before making changes to any settings, record the original values. If the setting changes do not achieve desired results, return settings to their original values.*

**NOTE**

*Feed the tube into the clamp so the natural curve of the tube is towards the outside of the black cover. This prevents the hose from looping around the black cover twice.*

- I. Gently push the hose into the black cover until it begins to feed.
- J. Allow the hose to feed itself through the pump until about 6" (15cm) remains on the entering side.
- K. Turn pump off.
- L. Connect the mix pump hose to the elbow fitting (located on the left side of the mix line manifold) using a small hose clamp. Be careful not to twist the mix hose.
- M. Turn the pump on.
- N. Allow the remaining 6" (15cm) of tubing to feed through the pump until the hose adapter prevents further feeding.
- O. Turn the pump off.
- E. Press SET button to enter edit mode.
- F. Press the up arrow button (↑) to increase the number to the value required. The value increases by 1 each time the up arrow button (↑) is pressed. After the value reaches 9, numbering restarts at 0.
- G. Press SET button to save the setting and exit the edit mode.
- H. Press the up arrow button (↑) once to navigate to the CabCtOut value. Record this value.
- I. Press SET button to enter edit mode.
- J. Press the up arrow button (↑) to increase the number to the value required. The value increases by 1 each time the up arrow button (↑) is pressed. After the value reaches 9, numbering restarts at 0.
- K. Press SET button to save the setting and exit the edit mode.
- L. Press the up arrow (↑) and left arrow (←) buttons to navigate to ExitMenu.
- M. Press the up arrow button (↑) from ExitMenu to return to the Mode Screen.
- N. Locate the Specification Sheet for SU412 Control behind the header panel and record the new values on this sheet.

 <b>CAUTION</b>
<b>Risk of Product Damage</b>
Air/Mix Tee must remain below the black cover clamp. If the Tee is above the pump, the mix may drain into the air compressor, resulting in pump damage.

- P. Connect the free end of the mix pump hose to the 3-way Tee. When all connections are complete, the 3-way Tee must be lower than the black pump housing.
- Q. The pump is now ready to sanitize.

**2.11 CAB TEMPERATURE ADJUSTMENT**

Cab temperature is monitored and controlled by two settings on the IntelliTec™ control: CabCutIn and CabCtOut. The cut in value determines the temperature at which the refrigeration cycle starts. The cut out setting determines when the cycle stops. To change the CabCutIn or CabCtOut, follow the steps below:

- A. Press and hold SEL button for 8 seconds. While still holding the SEL button, press the up arrow button (↑). The LCD Screen will read "Display".
- B. Release both buttons.
- C. Press the left arrow button (←) three (3) times to navigate to the Storage menu.

**2.12 DRIVE BELT TENSION ADJUSTMENT**

To check belt tension, follow the steps below:

- A. Remove a side panel and the back panel.

 <b>WARNING</b>
<b>Hazardous voltage</b>
The Main Freezer Power switch must be placed in the OFF position when disassembling for servicing. The freezer must be disconnected from electrical supply before removing any access panel. Failure to disconnect power before servicing could result in death or serious injury.

- B. Use a Burroughs Belt Tension Gauge to set the tension for the drive belt. Set the belt tension to 15 - 25 lbs.

- C. If an adjustment is necessary, loosen the four motor plate retaining nuts, adjust belt tension then retighten the four nuts.
- D. Using a straightedge, check that the drive motor pulley is aligned with the speed reducer pulley. Align the pulley if necessary.

**NOTE**

*Belt life will be increased if new drive belts are tightened after two or three weeks of operation.*

**2.13 CONDENSER CLEANING (AIR-COOLED FREEZERS)**

The condenser requires periodic cleaning. To clean the condenser, refer to the following steps:

- A. Lift the condenser filter off of the freezer cover panel. Visually inspect the condenser filter for dirt (Fig. 2-4).



**Figure 2-4 Removing Condenser Filter**

- B. If the condenser filter is dirty, vacuum or brush it clean. Rinse it with clean water and allow it to dry before replacing it on the freezer.

**NOTE**

*If the condenser is not kept clean, refrigeration efficiency will be lost.*

**2.14 PREVENTIVE MAINTENANCE**

It is recommended that a preventative maintenance schedule be followed to keep the freezer clean and operating properly. The following steps are suggested as a preventative maintenance guide.

The United States Department of Agriculture and the Food and Drug Administration require that lubricants used in food zones be certified for this use. Use lubricants only in accordance with the manufacturer's instructions.

- A. Daily checks  
Check for any unusual noise or condition and repair immediately.

- B. Monthly checks
  1. Check drive belts for wear and tighten belts if necessary. (Refer to section 2.12.)
  2. Check the condenser filter for dirt. (Refer to section 2.13.)

**2.15 EXTENDED STORAGE**

Refer to the following steps for winterizing the freezer or for storing the freezer over any long period.

- A. Clean all of the parts that come in contact with mix thoroughly with warm detergent . Rinse in clear water and dry all parts. Do not sanitize.

**NOTE**

*Do not let cleaning solution stand in freezer barrel or mix pump during the shutdown period.*

- B. Remove, disassemble, and clean the front door, auger shaft, and mix pump. Leave disassembled during the shutdown period.
- C. Place the plastic scraper blade in a plastic bag with a moist paper towel. This will prevent the flights from becoming brittle if exposed to dry air over an extended period (over 30 days).
- D. For water-cooled freezers that are left in unheated buildings, or buildings subject to freezing, the water must be shut off and disconnected. Disconnect the fittings at the water inlet and the water outlet lines of the freezer. The fittings are located at the rear of the freezer. Run the compressor for 2 - 3 minutes to open the water valve. Blow out all the water, first through the water inlet, then through the water outlet lines with air or carbon dioxide. Drain the water supply line coming to the freezer.
- E. Place the Pump OFF/ON switch and the Main Freezer Power OFF/ON switch in the OFF position.
- F. Disconnect the freezer from the source of the electrical supply in the building.



## SECTION 3 REFRIGERATION SYSTEM

### 3.1 REFRIGERATION SYSTEM

The U412/SU412 refrigeration system has two functions:

Medium-Temperature - Maintaining product temperature in the cab unit and providing refrigeration to the mix transfer line.

Low-Temperature - Producing and maintaining high quality shake in the freezing cylinder.

The system is designed for efficient use with R-448A or R-404A refrigerant. Refer to the machine's nameplate to confirm refrigerant.

The proper charge is indicated on the information plate.

### 3.2 REFRIGERANT RECOVERY & EVACUATION

Refer to the following procedures to properly recover and evacuate the refrigeration system. Do not purge refrigerant into the atmosphere.

### NOTE

*For qualified service personnel only. Anybody working with refrigerants must be certified as a Technician TYPE I as required by 40 CFR 82 Subpart F and hold all State and/or local refrigerant handling certifications. In addition, all handling, storage, and disposal of refrigerants must be in accordance with Environmental Protection Agency (EPA) guidelines and standards and all State and local guidelines and standards.*



### WARNING

#### Hazardous voltage

The Main Freezer Power switch must be placed in the OFF position when disassembling for servicing. The machine must be disconnected from electrical supply before removing any access panel. Failure to disconnect power before servicing could result in death or serious injury.

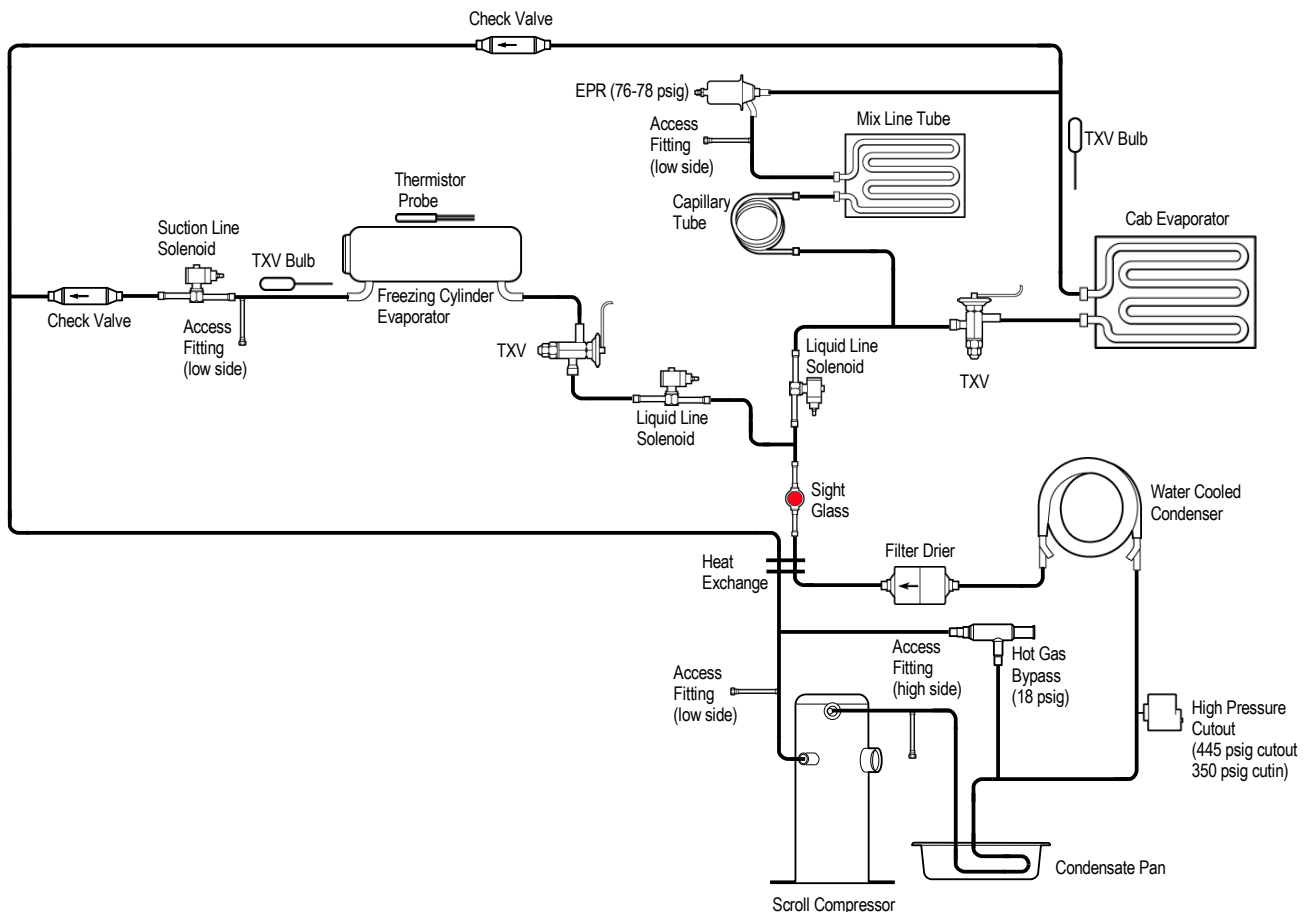

**Figure 3-1 Water Cooler Refrigeration System**

## A. Refrigerant Recovery

1. Disconnect the machine from the electrical supply before removing any panels for servicing.
2. Remove all panels.
3. Connect the recovery unit to the suction and discharge service valves of the compressor.
4. Locate the compressor contactor behind the header panel and disconnect the brown wire #65.
5. Wrap electrical tape around the wire to insulate it.
6. Remove the belt from the pulley to allow the drive motor to spin freely.
7. Connect power to the machine.
8. Turn the Main Power OFF/ON switch and Freezing Cylinder OFF/ON switch to the ON position.



### CAUTION

The solenoid valves must be energized to allow all refrigerant to be recovered and to prevent injury when brazing.

9. Press the Push To Freeze button on the IntelliTec control. This will energize the solenoid valves.
10. Operate the recovery unit per manufacturer's instructions.

### NOTE

*If recovery is not completed after 20 minutes, press the Push To Freeze button again. This will keep the solenoid valves open.*

## B. Evacuating the Refrigeration System

1. Close any open ports in the refrigeration system.
2. Connect a vacuum gauge to one of the access fittings next to an evaporator.
3. Connect the evacuation unit to the suction and discharge service valves of the compressor.
4. Locate the compressor contactor behind the header panel and disconnect the brown wire #65.
5. Wrap electrical tape around wire to insulate it.
6. Remove belts from the pulleys to allow drive motors to spin freely.
7. Connect power to the machine.
8. Turn the Main Power OFF/ON switch and Freezing Cylinder OFF/ON switches to the ON position.
9. Press the Push To Freeze button on the IntelliTec control. This will energize the solenoid valves.
10. Evacuate the system until the gauge reads 300 microns of mercury (300 $\mu$  Hg) for 5 continuous minutes.

## NOTE

*If evacuation is not completed after 20 minutes, press the Push To Freeze button again. This will keep the solenoid valves open.*

11. If the system will not maintain a standing vacuum test with the vacuum pump off (gauge increases towards atmosphere), find the leak, fix it, and evacuate again.

## 3.3 REFRIGERANT CHARGING

Refer to the following procedures to properly charge the refrigeration system. Stoelting recommends liquid refrigerant charging.

### NOTE

*For qualified service personnel only. Anybody working with refrigerants must be certified as a Technician TYPE I as required by 40 CFR 82 Subpart F and hold all State and/or local refrigerant handling certifications. In addition, all handling, storage, and disposal of refrigerants must be in accordance with Environmental Protection Agency (EPA) guidelines and standards and all State and local guidelines and standards.*

- A. Ensure the electrical supply has been removed before continuing.



### WARNING

#### Hazardous voltage

The Main Freezer Power switch must be placed in the OFF position when disassembling for servicing. The machine must be disconnected from electrical supply before removing any access panel. Failure to disconnect power before servicing could result in death or serious injury.

- B. If the system has been opened or if there was a leak, refer to Section 3.2 - Refrigerant Recovery and Evacuation to evacuate the system prior to charging.
- C. Refer to machine's information plate for total charge requirements.

### NOTE

*The refrigeration system of the U412/SU412 is critically charged. Be sure to charge the system to the weight listed on the machine's information plate.*

- D. For liquid refrigerant charging, connect refrigerant cylinder to the discharge access fitting of the compressor.
- E. Energize the three solenoid valves. There are two liquid line solenoids and one suction line solenoid.
- F. Add the proper amount of refrigerant according to the machine's information plate.

### 3.4 COMPRESSOR

The U412 and SU412 have a scroll type compressor (Refer to Figure 3-2). This compressor type uses two spiral shaped scrolls to compress gas. One scroll rotates around an identical stationary scroll. Gas is drawn into the compression chamber by the rotating scroll and is compressed as it moves towards the center of the chamber. Operation of this compressor is continuous because, during each rotation, several gas 'pockets' are compressed simultaneously.

Details of the compressor's starting components are in Section 6.



Figure 3-2 Scroll Type Compressor

#### A. Winding Test

To test the compressor motor windings for possible problems, perform the following steps:

- A. Disconnect the machine from electrical supply before removing any panels for servicing.
- B. Remove the left side panel.
- C. Pull the compressor connector plug off of the compressor. The compressor has three terminals; C (common), R (run), and S (start). (Refer to Figure 3-3.)



Figure 3-3 Compressor Connection

- D. Connect an ohmmeter to the C and R terminals. Resistance through the run winding should be  $1.81\Omega \pm 10\%$ .
- E. Connect ohmmeter to terminals C and S. Resistance through the start winding should be  $2.27\Omega \pm 10\%$ .
- F. To check if windings are shorted to ground, connect one ohmmeter lead to a bare metal part on the compressor (such as any copper line leading to or from the compressor) and check terminals C, R, and S.

#### NOTE

*The compressor is equipped with an internal overload protector. If the compressor is warm and ohmmeter readings indicate an open winding, allow up to one hour for overload to reset.*

#### B. Compressor Removal

- A. Disconnect the machine from electrical supply before removing any panels for servicing.
- B. Disconnect the electrical plug from the compressor.
- C. Recover refrigerant charge per the instructions in Section 3.2.
- D. Leave the suction and discharge ports open to prevent pressure buildup during compressor removal.
- E. Remove six inches of insulating tubing on the suction line going to the compressor and unsweat the suction and discharge line from the compressor.
- F. Remove the four nuts and washers from the base of the compressor.
- G. Remove the compressor through the side of the machine.
- H. Remove the four rubber compressor mounts from the compressor.
- I. Crimp and braze all open ports of the old compressor.

#### NOTE

*A compressor returned to Stoelting with any open ports will void the warranty. ALWAYS crimp and braze ports on a compressor that has been removed.*

#### C. COMPRESSOR INSTALLATION

- A. Disconnect the machine from electrical supply before removing any panels for servicing.
- B. Install the four rubber mounts on the compressor.



## WARNING

### Hazardous voltage

The Main Freezer Power switch must be placed in the OFF position when disassembling for servicing. The machine must be disconnected from electrical supply before removing any access panel. Failure to disconnect power before servicing could result in death or serious injury.

- C. Install the compressor into the machine, fitting the base over the four bolt holes.
- D. Install the four washers and nuts onto the bolts and tighten securely.
- E. Remove all tubing plugs from the replacement compressor.

### NOTE

*The compressor plugs protect the compressor from moisture in the air. Do not remove the plugs until you are ready to install. The compressor must not be opened to the atmosphere for more than 10 minutes.*

- F. Leave the suction and discharge ports open to prevent pressure buildup. Braze the suction and discharge line to the compressor.
- G. Connect the electrical plug to the compressor. The plug is keyed and will only install one way. (Refer to Figure 3-3.)
- H. Replace the drier per the instructions in Section 3.9.
- I. Evacuate the system per the instructions in Section 3.2
- J. Recharge the system per the instructions in Section 3.3.
- K. Replace the insulating tubing on the suction line.

## 3.5 CONDENSER

The U412 and SU412 are available with a water-cooled or an air-cooled condenser. The capacity of the machine is directly related to keeping the condenser clean and free of debris.

The water-cooled condenser is a tube and shell type. This condenser requires cool, clean water to function properly. Inlet and discharge lines must be 3/8" ID minimum.

The air-cooled condenser is a copper tube and aluminum fin type. The machine must have a minimum of 3" of clearance on the sides and 6" clearance at the back for proper air flow.

### Condenser Testing

The condenser can be checked for leaks using the bubble test or using a leak detector.

## 3.6 EVAPORATOR

The U412 and SU412 have a freezing cylinder evaporator, a cab evaporator, and a mix line evaporator.

### Evaporator Testing

The evaporator can be checked for leaks using the bubble test or using a leak detector.

### NOTE

*Foam insulation in the evaporator will set off electronic leak detectors if disturbed.*

## 3.7 VALVES

### A. Thermostatic Expansion Valve (TXV)

The Thermostatic Expansion Valve (TXV) is used to meter the refrigerant to the evaporator. It does so by maintaining a low, constant superheat in the evaporator. The self-regulating TXV is preset by the manufacturer and adjustment is not recommended. Figure 3-4.

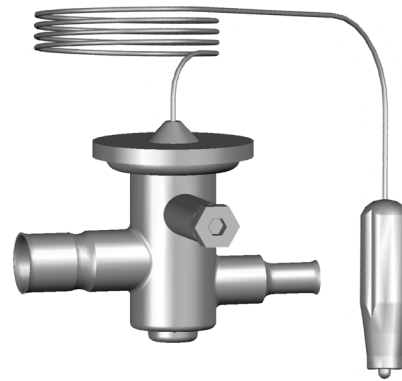

**Figure 3-4 TXV**

### TXV Testing & Adjustment

When testing a TXV, run only the evaporator that the TXV meters. If checking the cab TXV, place the freezing cylinder switch in the OFF position.

### NOTE

*The bulb has an indent which must be positioned against the tubing. Good contact between the bulb and the suction line is necessary for proper operation of the valve. The bulb must also be well insulated.*

- A. Connect a gauge to the access fitting on the suction line next to the evaporator.
- B. Connect a thermocouple to the suction line next to the evaporator.
- C. Immediately before the refrigeration cycle ends, the gauge should read between 20-22 psig.

- D. If the pressure reading is higher than expected, check to see if there is an overcharge of refrigerant.
- E. If the pressure reading is lower than expected, check to see if there is a low refrigerant charge or if there is a restriction in the system.

**NOTE**

*The TXV is the LAST component to adjust in the refrigeration system.*

- F. The TXV can be adjusted after the steps above are completed. When adjusting, do not turn the valve over 1/4 turn (90°). Turn the valve stem clockwise to increase the superheat or counterclockwise to decrease the superheat.

**TXV Removal**

- A. Remove the side panel.
- B. Remove bulb from suction line exiting from the evaporator.
- C. Recover refrigerant charge per instructions in Section 3.2.
- D. Leave the suction and discharge ports open to prevent pressure buildup during TXV removal.
- E. Remove any insulation from the TXV and immediate surrounding lines.
- F. Apply a heat sink (wet cloth) to the valve dome (Figure 3-5).
- G. Unsweat the TXV and remove.

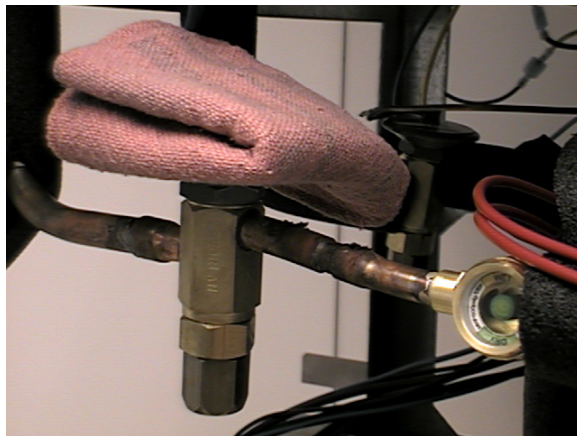

**Figure 3-5 TXV Removal**

**TXV Replacement**

To replace the TXV, perform the following procedures:

- A. Position the TXV with a heat sink into the system.
- B. With the suction and discharge ports open, braze the TXV into the system using appropriate brazing material.
- C. Remove the heat sink from the TXV.

- D. Install bulb on suction line exiting the evaporator using existing clamp. The bulb has an indent that must be placed against the tubing.

**NOTE**

*Good contact between the bulb and the suction line is necessary for proper operation of the valve. The bulb must also be well insulated.*

- E. Tighten clamp to 20 in/lb using a torque wrench.
- F. Replace insulation to the TXV and surrounding lines.
- G. Replace the drier per the instructions in Section 3.9.
- H. Evacuate the system per the instructions in Section 3.2.
- I. Recharge the system per the instructions in Section 3.3.

**B. Check Valve**

The U412 and SU412 have 2 magnetic check valves (Refer to Figure 3-6). Each valve is positioned in the suction line and prevents backflow of refrigerant into the evaporator. If there is reversed flow, the product in the freezing cylinder softens and liquid refrigerant can flood into the compressor on startup.

If a check valve needs to be replaced, use a heat sink (wet cloth) when installing the new valve to prevent damage.



**Figure 3-6 Check Valve**

**C. High Pressure Cutout**

The high pressure cutout stops the compressor if the discharge pressure reaches 445 psig.

**High Pressure Cutout Test**

- A. Connect a gauge to the access fitting on the discharge line.

- B. Disconnect cooling:  
Air-Cooled - Disconnect evaporator fan  
Water-Cooled - Shut off water supply
- C. High pressure cutout should trip when pressure reaches 445 psig  $\pm$ 9.

#### High Pressure Cutout Removal

- A. Remove the left side panel.
- B. Recover refrigerant charge per instructions in Section 3.2.
- C. Leave the suction and discharge ports open to prevent pressure buildup during removal.
- D. Unsweat the high pressure cutout from the suction line.
- E. Disconnect the terminals from high pressure cutout.

#### High Pressure Cutout Replacement

- A. With the suction and discharge ports open, braze the capillary tube to the discharge line.
- C. Replace the drier per the instructions in Section 3.9.
- D. Braze bulb into place on suction line.
- E. Evacuate the system per the instructions in Section 3.2.
- F. Recharge the system per the instructions in Section 3.3.
- G. Connect the pink wire to the COM terminal and the brown/gray wires to the #2 terminal.
- H. Attach the high pressure cutout to the top of the inside of the header panel using the two screws with star washers.

#### D. Hot Gas Bypass

The hot gas bypass valve is installed in parallel to the compressor and helps to regulate the compressor temperature (Refer to Figure 3-7). When the cab evaporator is the only part of the system requiring refrigerant, the bypass valve will allow discharge gas to bypass into the suction line to prevent liquid refrigerant from entering the compressor.

#### Hot Gas Bypass Adjustment

##### NOTE

*Before adjusting the hot gas bypass, check the EPR valve and adjust if necessary.*

- A. Turn the Main Power OFF/ON switch and the Freezing Cylinder OFF/ON switch in the OFF position.
- B. Connect a gauge to the access fitting on the suction line next to the compressor.

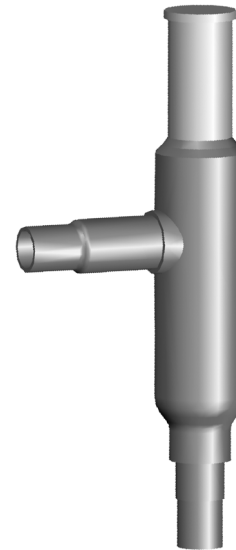

**Figure 3-7 Hot Gas Bypass**

- C. Open the cab door and place a piece of tape on the cab door interlock switch.

##### NOTE

*The cab door remains open for this test. The relatively warm ambient air will keep the cab refrigeration running.*

- D. Turn the Main Power OFF/ON switch to the ON position.
- E. Wait 3 minutes to allow the gauge to stop moving.
- F. Unscrew the seal cap from the top of the valve.
- G. Using a 5/16" Allen wrench, adjust the valve counterclockwise to decrease pressure and clockwise to increase pressure. (Refer to Figure 3-8)

##### NOTE

*Each 360° turn will change the pressure about 6 psig.*

- H. Adjust the hot gas bypass valve to 18 psig  $\pm$ 1.



**Figure 3-8 Hot Gas Bypass Adjustment**

- I. Wait 2 minutes to ensure pressure remains stable.
- J. Hand-tighten seal cap to valve.

### Hot Gas Bypass Removal

- A. Remove the side and rear panels.
- B. Recover refrigerant charge per instructions in Section 3.2.
- C. Remove insulation around hot gas bypass and tubing.
- D. Leave the suction and discharge ports open to prevent pressure buildup during hot gas bypass removal.
- E. Apply a heat sink (wet cloth) to the hot gas bypass.
- F. Unsweat the hot gas bypass and remove.

### Hot Gas Bypass Replacement

To replace the hot gas bypass, perform the following procedures:

- A. Apply a heat sink (wet cloth) to the hot gas bypass.
- B. With an open port, braze the hot gas bypass into the system using appropriate brazing material.
- C. Remove the heat sink from the hot gas bypass.
- D. Replace the filter drier. Refer to Section 3.8 for details.
- E. Evacuate and recharge system per instructions in Section 3.2.

### E. Evaporator Pressure Regulator (EPR)

There is one EPR in the U412/SU412 refrigeration system (Refer to Figure 3-9). It is located on the suction line of the refrigerated mix line and regulates evaporator refrigerant pressure.

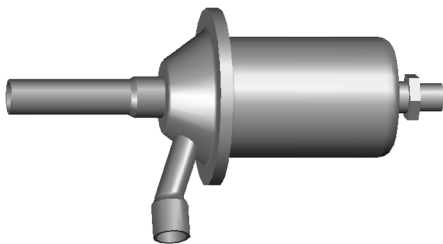

**Figure 3-9 EPR Valve**

### EPR Test & Adjustment

- A. Place the Main Power OFF/ON switch and both Freezing Cylinder OFF/ON switches in the OFF position.
- B. Connect a gauge to the access fitting on the suction line between the mix line evaporator and the EPR.
- C. Place the Main Power OFF/ON switch to the ON position and place the Freezing Cylinder OFF/ON switch to the OFF position

- D. Open the cab door and place a piece of tape on the cab door interlock switch.

### NOTE

*The cab door remains open for this test. The relatively warm ambient air will keep the cab refrigeration running.*

- E. If the gauge does not read  $78 \pm 2$  then adjustment is needed.
- F. Remove the plastic cap and loosen the locknut on the EPR. Using a small screwdriver, turn the adjustment screw counterclockwise 1/2 turn, then adjust as necessary. Turn the valve stem clockwise for higher pressure or counterclockwise for lower pressure.
- G. Allow the system to stabilize for 5 minutes to ensure pressure remains stable.

### EPR Removal

- A. Remove the side panel.
- B. Recover refrigerant charge per instructions in Section 3.2.
- C. Leave the suction and discharge ports open to prevent pressure buildup during EPR removal.
- D. Unsweat the EPR and remove.

### EPR Replacement

To replace the EPR, perform the following procedures:

- A. Apply a heat sink (wet cloth) to the EPR.
- B. With an open port, braze the hot gas bypass into the system using appropriate brazing material.
- C. Remove the heat sink from the hot gas bypass.
- D. Replace the filter drier. Refer to Section 3.8 for details.
- E. Evacuate and recharge system per instructions in Section 3.2.

### F. Water Valve (Water Cooled Models Only)

The water valve monitors refrigerant pressure and opens on an increase of pressure. The opening point pressure is the refrigerant pressure required to lift the valve disc off the valve seat. (Figure 3-10)

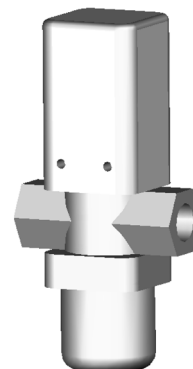

**Figure 3-10 Water Valve**

### Water Valve Adjustment

- A. Remove the back panel.
- B. Connect a gauge to the compressor discharge access fitting.
- C. Connect the machine to the electrical supply, start the refrigeration cycle, and read the pressure.
- D. The proper gauge reading should be 225-235 psig. The exit water temperature should be 95-107°F.
- E. If the water temperature and high side pressure are too low, the opening point pressure should be increased to slow the water flow. Turn the adjustment screw counterclockwise.
- F. If the water temperature and high side pressure are too high, the opening point pressure should be decreased to increase the flow of water. Turn the adjustment screw clockwise.

### Water Valve Removal

The water valve is connected to the refrigeration system by capillary tube brazed to the discharge line.

- A. Turn off and disconnect the water supply. Blow out the water lines with compressed air or CO<sub>2</sub>.
- B. Recover refrigerant charge per instructions in Section 3.2.
- C. Leave the suction and discharge ports open to prevent pressure buildup during water valve removal.
- D. Unsweat the capillary tube from the discharge line.
- E. Remove the clamps from the water lines at the valve.
- F. Remove the two screws holding the water valve to the frame and remove the valve.

### Water Valve Replacement

To replace the water valve, perform the following procedures:

- A. Position the water valve and attach to the frame using the two screws.
- B. Install the water lines onto the valve with hose clamps.
- C. Leave the suction and discharge ports open to prevent pressure buildup during water valve installation.
- D. Braze the capillary tube into the system using appropriate brazing material.
- E. Connect the water supply line and turn on the water supply.
- F. Check for leaks in the water lines. If there are no leaks, turn off the water supply.
- G. Replace the filter drier. Refer to Section 3.8.
- H. Evacuate and recharge system per instructions in Section 3.2.

- I. Turn on the water and check for leaks in the water lines with the refrigeration system running.
- J. Adjust the valve as necessary.

### 3.8 SOLENOID

Solenoid valves are installed on the liquid and suction lines of the freezing cylinder evaporator.

A solenoid valve has a magnetic coil that, when energized, lifts a plunger and allows refrigerant to flow. The solenoids are activated by the IntelliTec™ control and determine which evaporator receives refrigeration.

The suction line solenoid prevents refrigerant flow in the evaporator when the suction pressure drops due to the operation of the other evaporators in the system.

The solenoid valves are rated IP65. They have complete protection against dust and are water resistant. To maintain this rating, the coil wiring must be positioned downwards or to the side and a torque driver must be used to attach the wire connector shell to the coil.

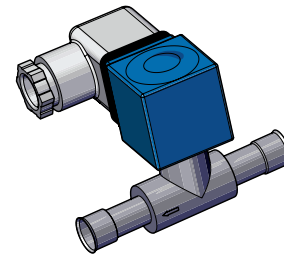

Figure 3-11 Suction Line Solenoid Valve

### ACTIVATING A SOLENOID

To open a solenoid, follow these steps:

- A. Turn the machine on by pressing the Main Power Off/On button.
- B. Press the right arrow, SET, then the SEL button to access the technician level on the control.
- C. Navigate to the Left Output Control or Right Output Control menu which is located under Utilities in the Testing and Manual Operation screen. Refer to Section 4 for details.
- D. Activate the solenoid by moving the cursor to the Liquid Solenoid option and pressing the SET button.

### NOTE

*Any energized component will de-energize after leaving the Testing and Manual Operations menu.*

- E. Check for leaks in the water lines. If there are no leaks, turn off the water supply.
- F. Replace the filter drier. Refer to Section 3.9.

## SUCTION LINE SOLENOID TESTING

To check for leaking valve seats, follow the procedure below. The liquid line solenoid must remain open.

### NOTE

**Machine barrels must NOT contain frozen product for this test.**

- A. Turn the machine off by pressing the Main Power On/Off button.
- B. Attach a gauge to the Schrader valve located after the evaporator of the side being tested.
- C. Turn the machine on by pressing the Main Power Off/On button.
- D. Turn the opposite side Freezing Cylinder on by pressing the On/Off Left or On/Off Right button.

### NOTE

*If checking the solenoid on the left side, press the On/Off Right button. For the right side, press the On/Off Left button.*

- E. Start a freezing cycle of the opposite side by pressing the Push To Freeze button or by pulling the spigot handle.
- F. If the pressure drops more than 3 psi in 30 seconds on the side being tested, the suction line solenoid valve seat leaks and should be replaced. Repeat the procedure for the other side.

## LIQUID LINE SOLENOID TESTING

The following test will check if a liquid line solenoid has a leaking valve seat. The power to the solenoid is disconnected and refrigerant flow is monitored through the system. If the valve seat does not leak, the suction pressure during the test will be low.

- A. Attach a gauge to the Schrader valve on the suction line.
- B. Turn the machine on by pressing the Main Power Off/On button.
- C. Press the right arrow, SET, then the SEL button to access the technician level on the control.
- D. Navigate to the Left or Right Output Control or Right, located under Utilities in Testing and Manual Operation screen. Refer to Section 4.
- E. Activate compressor by moving the cursor to the compressor option and pressing the SET button.
- F. The gauge should read well below 21 psig after 1 minute.
- G. A leaking valve seat may also show frost on the liquid line tubing just past the solenoid, before the evaporator.

## SOLENOID MAGNETIC COIL REMOVAL



### WARNING

#### Hazardous voltage

The machine must be disconnected from the electrical supply before servicing. Failure to disconnect power before servicing could result in death or serious injury.

- A. Disconnect the machine from the electrical supply before removing any panels for servicing.
- B. Remove the side panel.
- C. Identify and disconnect the two wires from the solenoid coil.
- D. Pull the solenoid coil off of the valve stem.

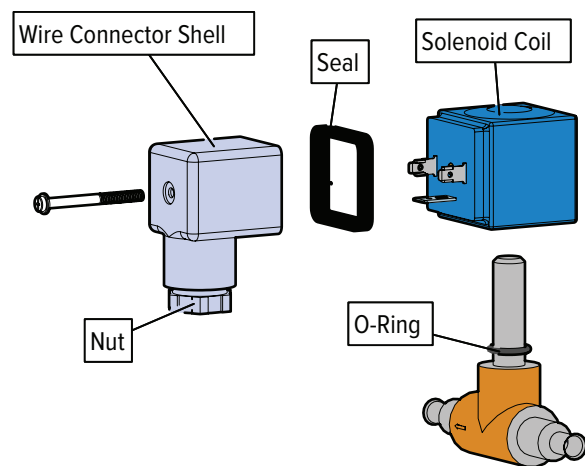

Figure 3-12 Solenoid Coil Parts

## SOLENOID MAGNETIC COIL INSTALLATION

- A. Install the O-ring onto the valve stem.
- B. Push the coil on to the solenoid valve stem until it clicks. Make sure the coil is fully seated over the O-ring and against the valve body.
- C. Make sure there isn't any foam insulation between the valve coil and valve body. Trim any excess insulation.
- D. Connect wires to appropriate terminals.

## SOLENOID VALVE REMOVAL



### CAUTION

A heat sink (wet cloth) must be used to prevent damage to the valve and a port must remain open to prevent pressure buildup!

- A. Recover refrigerant charge per Section 3.2.
- B. Disconnect two wires from solenoid coil.

- C. Pull coil off the valve stem.
- D. Remove insulation around valve and attached refrigeration lines.
- E. Remove magnetic coil per instructions above.
- F. Apply heat sinks (wet cloth) to the insulated refrigerant lines near the valve.
- G. Leave a port open to prevent pressure buildup.
- H. Unsweat the solenoid and remove.
- I. Cap refrigeration system if valve is not replaced within 10 minutes to prevent contamination.

### SOLENOID VALVE REPLACEMENT

- A. Position the new solenoid with the arrow pointing toward the direction of flow.
- B. Apply a heat sink (wet cloth) to the solenoid valve.

 <b>CAUTION</b>
<p>A heat sink (wet cloth) must be used to prevent damage to the valve and a port must remain open to prevent pressure buildup!</p>

- C. With suction and discharge ports open, purge with nitrogen and braze the solenoid into the system.
- D. Remove the heat sink from the valve.
- E. Replace insulation around valve.
- F. Replace the filter drier per Section 3.9.
- G. Evacuate and recharge system per Section 3.2.

### 3.9 FILTER DRIER

Filter drier must be replaced every time refrigeration system is opened for service. A new filter drier improves operation of the entire refrigeration system by stopping moisture circulation and removing harmful contaminants.

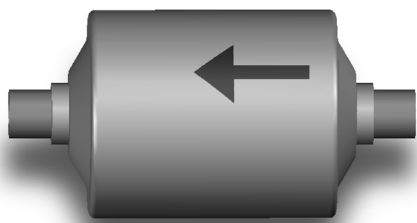

**Figure 3-12 Filter Drier**

#### Filter Drier Removal

- A. Recover refrigerant charge per Section 3.2.
- B. Cut the refrigeration line as close to the filter drier as possible and remove drier.
- C. Cap ends of drier using plugs from new drier.

### NOTE

**Cap drier to prevent moisture entry.**

#### Filter Drier Replacement

- A. Position filter drier so arrow is pointing toward evaporators (away from the condenser).
- B. Apply a heat sink (wet cloth) to the filter drier.
- C. With suction and discharge ports open, braze filter drier into the system using appropriate brazing material.
- D. Evacuate the system per Section 3.2.
- E. Recharge the system per Section 3.3.

### 3.10 CAPILLARY TUBE

The capillary tube meters refrigerant flow in the mix line evaporator (Refer to Figure 3-13). Amount of flow depends on the length and ID of capillary tube and refrigerant charge.

#### Capillary Tube Removal

- A. Recover refrigerant charge per Section 3.2.
- B. Leave a port open to prevent pressure buildup during capillary tube removal.
- C. Remove foam insulation from the capillary tube at evaporator inlet.
- D. Unsweat the capillary tube and remove.

#### Capillary Tube Replacement

- A. Position the capillary tube in place.
- B. Apply a heat sink (wet cloth) to the capillary tube.
- C. With suction and discharge ports open, braze capillary tube into the system using appropriate brazing material.
- D. Replace foam insulation to capillary tube at evaporator inlet.
- E. Evacuate the system per Section 3.2.
- F. Recharge the system per Section 3.3.

### 3.11 CAB UNIT

The IntelliTec control is programmed to handle refrigeration of the cabinet independently from the barrel. The control maintains cabinet temperature between two preset values (CabCutIn and CabCtOut). If the cabinet door is opened during a refrigeration cycle, the evaporator fan will continue to run but the refrigeration cycle will be interrupted to prevent the evaporator coils from icing up.

The refrigeration will run for a maximum of 4 minutes. After this time is reached, the refrigeration cycle will stop for a minimum of 3 minutes. At the expiration of 3 minutes, the control will check cabinet temperature. If product temperature is at or above CabCutIn, a refrigeration cycle will start.

To adjust temperature, refer to Section 4-4 Obtaining Readings and Modifying Settings.

## SECTION 4 ELECTRICAL & MECHANICAL CONTROL SYSTEMS

### NOTE

The wiring diagram is available in Section 6.

#### 4.1 INTELLITEC™ CONTROLLER

The IntelliTec control is Stoelting's most advanced controller. It combines all of the best features of previous controllers with advanced sensing and troubleshooting capabilities.

Understanding the modes of operation and individual control settings will make servicing the control straightforward.

##### A. COMPONENTS OF CONTROLLER

The IntelliTec control consists of three main components; the control board (Figure 4-1), the membrane switch (Figure 4-2), and the display panel module (Figure 4-3). The membrane switch is connected to the display panel module via a 9-pin ribbon cable. The display panel module is connected to the IntelliTec control board through a telephone cord. The IntelliTec control board is connected to the machine through an 8-pin connector, a 7-pin connector, and a 6-pin connector.

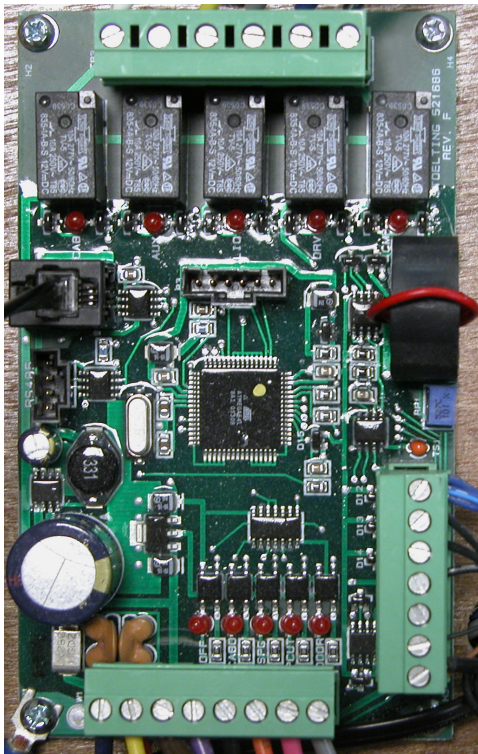

Figure 4-1 IntelliTec Control Board

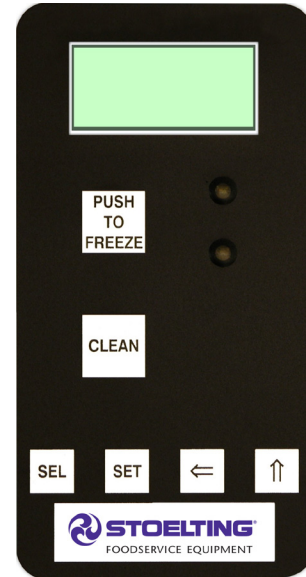

Figure 4-2 Membrane Switch

#### 4.2 CONTACTORS

The compressor and drive motor contactors are mounted inside the electrical box behind the header panel. There is one contactor for the compressor and a contactor for each drive motor.

The IntelliTec control sends electronic signals to trigger the contactors. Separate signals are used to control each drive motor contactor and the compressor contactor. The signals to the contactors are staggered, so the drive motor will always start and stop three seconds before the compressor. By staggering the starting and stopping of the drive motor, maximum starting torque is available and voltage spikes are reduced.

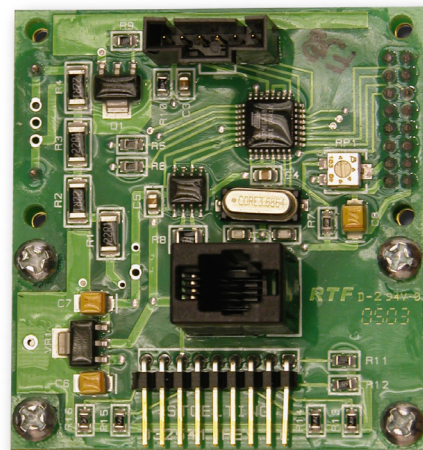

Figure 4-3 Display Panel Module

## A. CONTACTOR TESTS

The following tests will show if a contactor is working properly.

1. Open header panel and visually check the IntelliTec control board.
2. Check for a signal going to contactor. When the spigot is opened or the Push To Freeze button is pressed, the DRV LED on the control board will light up. After three seconds, the CMP LED will light up (Refer to Figure 4-4). If the LEDs do not light up, refer to Section 7 Troubleshooting.

### NOTE

*In addition to the LEDs lighting, there will be an audible click from the contactors and the motor and compressor will start.*

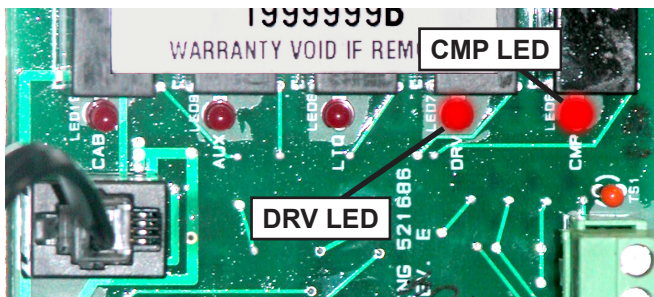

Figure 4-4 IntelliTec LEDs

3. Check to ensure contactor is receiving signal. Read voltage across the coils of the contactor during a freezing cycle. Voltage should be about 115V. If there is no voltage reading, refer to Section 7 Troubleshooting.

## 4.3 DRIVE MOTOR

The drive motor is used to rotate the auger assembly. An internal, normally closed, centrifugal switch starts the drive motor. The motor has an internal thermal overload.

### A. DRIVE MOTOR REMOVAL

1. Disconnect machine from electrical supply before removing any panels for servicing.
2. Remove the back panel and the right side panel.
3. Remove the electrical cover plate from the back of the motor.
4. Identify (mark) wires and remove them from the motor.
5. Remove protective shield from side of machine. (Refer to Figure 4-5)

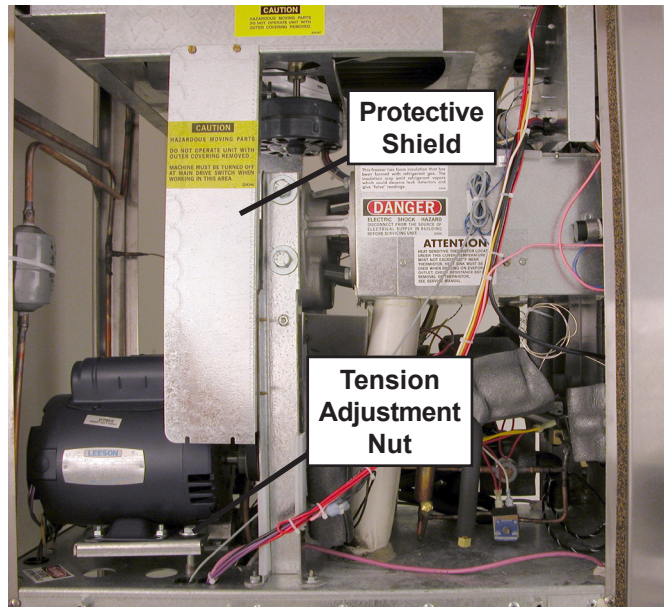

Figure 4-5 Motor Removal

6. Loosen the belt tension adjustment nut and remove the belt. (Refer to Figure 4-5)
7. Remove the motor mounting bolts and shims.
8. Loosen the two allen head screws from the pulley.
9. Remove the pulley and key from the motor shaft.

### B. DRIVE MOTOR INSTALLATION

1. Place the drive motor in position and install the four mounting bolts and shims.
2. Place the pulley and key on the motor shaft.

### NOTE

*Do not tighten the pulley screws until after the belt tension has been properly adjusted.*

3. Install the belt and tighten the tension bolt.
4. Use a Burroughs Belt Tension Gauge to set the tension for the drive belt. Set the belt tension to 15 - 25 lbs.
5. Using a straightedge, align the drive motor pulley with the gearbox pulley. Tighten the two allen head screws.
6. Install wiring according to wiring diagram (located behind header panel). Install electrical cover plate.
7. Install protective shield.
8. Install back and side panel.

## 4.4 CAPACITORS

The compressor start and run contactors are mounted behind the side panels. The start and run capacitors for the drive motor is mounted directly onto the motor body.

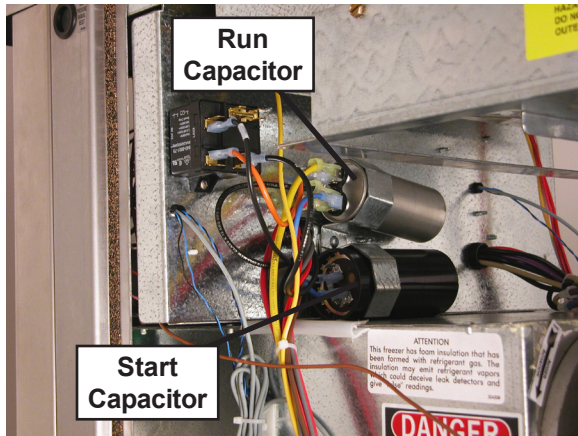

Figure 4-6 Compressor Capacitors

### A. CAPACITOR TEST

1. Disconnect machine from electrical supply before removing any panels for servicing.
2. Place the Main Power OFF/ON switch and the Freezing Cylinder OFF/ON switch in the OFF position. Remove the right side panel.
3. Remove a lead from one of the capacitor terminals.

	<b>WARNING</b>
<b>Hazardous voltage</b>	
<p>The Main Freezer Power switch must be placed in the OFF position when disassembling for servicing. The machine must be disconnected from electrical supply before removing any access panel. Failure to disconnect power before servicing could result in death or serious injury.</p>	

4. Using insulated pliers, discharge the capacitor by connecting a 20KΩ 5W resistor across the terminals.

#### NOTE

*Discharge the capacitor even if there is a bleeder resistor across the terminals. There may be an open in the bleeder resistor preventing it from working properly.*

5. Disconnect the bleeder resistor from the circuit.
6. Check the capacitance across the terminals. Refer to the table below for the correct readings.

	Part	Rating	
		MFD	VAC
Drive Motor Run	231078	50 MFD	370 VAC
Drive Motor Start	231095	500 MFD	125 VAC
Compressors - Start	230638	88-106 MFD	330 VAC
Compressors - Run	230652	35 MFD	440 VAC
Compressors - Run	231057	35 MFD	370 VAC

### B. CAPACITOR REPLACEMENT

1. Disconnect machine from electrical supply before removing any panels for servicing.
2. Place the Main Power OFF/ON switch and the Freezing Cylinder OFF/ON switch in the OFF position.
3. Remove leads from the capacitor terminals.
4. Using insulated pliers, discharge the capacitor by connecting a 20KΩ 5W resistor across the terminals.

#### NOTE

*Discharge the capacitor even if there is a bleeder resistor across the terminals. There may be an open in the bleeder resistor preventing it from working properly.*

5. Pull the capacitor out of its holder and replace. Make sure the new capacitor has a bleed resistor.
6. Connect the leads to the terminals.

## 4.5 GEARBOX

### A. GEARBOX INSPECTION

Inspect the gearbox and listen for unusual noise. A grinding sound generally indicates a bad gear.

### B. GEARBOX REMOVAL

1. Disconnect the machine from electrical supply before removing any panels for servicing.
2. Remove the front door and remove the auger shaft.
3. Remove the back panel and right side panel.
4. Remove protective shield from the side of the machine.
5. Remove the belt.
7. Remove the pulley by loosening the set screws.
8. Remove the four bolts holding the gearbox to the barrel and mounting bracket.
9. Remove the gear box.

### C. GEARBOX INSTALLATION

1. Place the gear box in position and install the four bolts. Make sure the bolts pass through the mounting bracket and gear box.
2. Tighten the bolts.
3. Mount the pulley on the gear box shaft and align it with the motor pulley, then tighten the allen head screws.
4. Install the belt.

5. Use a Burroughs Belt Tension Gauge to set the tension for the drive belt. Set the belt tension to 15-25 lbs.
7. If an adjustment is necessary, loosen the four motor plate retaining nuts, adjust belt tension then retighten the four nuts.
8. Install the auger shaft and front door.

#### 4.6 CONDENSER FAN MOTOR (AIR-COOLED ONLY)

##### A. FAN MOTOR REPLACEMENT

1. Disconnect machine from electrical supply before removing any panels for servicing.
2. Remove a side panel and the header panel.

 <b>WARNING</b>
<b>Hazardous voltage</b> The Main Freezer Power switch must be placed in the OFF position when disassembling for servicing. The machine must be disconnected from electrical supply before removing any access panel. Failure to disconnect power before servicing could result in death or serious injury.

3. Trace and disconnect the black and white wires on the T1 and T2 terminals on the compressor contactor.
4. Loosen set screw on fan blade.
5. Remove the three bolts from the fan motor mounting plate and remove the motor.

##### B. FAN MOTOR INSTALLATION

1. Attach motor to the mounting plate with the three bolts.
2. Place fan blade on motor shaft and tighten set screw.
3. Ensure purple wire is terminated.
4. Ensure red wire is terminated with blue wire.
5. Route white and black wires through the front panel to the compressor contactor.
6. Connect black wire to the T1 terminal.
7. Connect white wire to the T2 terminal.

#### 4.7 CAB CONDENSER FAN MOTOR

##### A. FAN MOTOR REPLACEMENT

1. Shut the machine down and remove mix from the freezing barrel and cab.
2. Disconnect machine from electrical supply.
3. Remove the mix container and sliding drawer from the cab.
4. Disconnect the evaporator drain tube and remove the two thumb screws on the evaporator cover. Pull the cover off and set aside.
5. Remove the tubes from the mix transfer line and air line.
6. Remove the four screws on the fan shroud. The screws are attached to the cab wall.
7. Pull thermistor out of the clip and thread it up through the hole in the fan shroud.
8. Remove the fan shroud by tilting forward and pulling down (Refer to Figure 4-7).

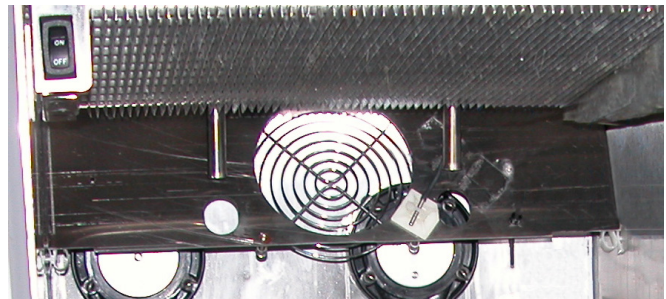

Figure 4-7 Cab Fan Shroud

9. Remove the two fan bracket screws and disconnect wires.
10. Connect the wires to the new fan motor.
11. Attach the two screws to the fan motor bracket.
12. Tilt the fan shroud and move it into place.
13. Thread thermistor through hole in fan shroud and attach it to the clip.
14. Install fan shroud into cab with the four screws.
15. Install evaporator cover with the two thumb screws.
16. Install all tubes and replace sliding drawer and mix containers.

## 4.8 SWITCHES

### A. SPIGOT SWITCH

The spigot switch is a normally closed, held open switch. When the spigot is pulled, the spigot switch sends a signal to the IntelliTec control to start the auger drive and refrigeration system. This signal moves the control to “Serve Mode”, or if it already is in “Serve Mode”, it resets the cycle count. After serving product, the IntelliTec continues a freezing cycle until the product reaches consistency.

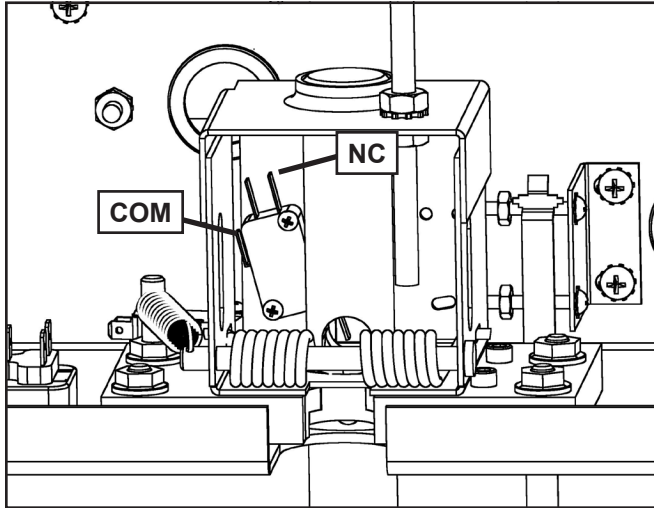

Figure 4-8 spigot Cam Assembly

### SPIGOT SWITCH TEST - ADJUSTMENT

#### NOTE

*Adjustments to the spigot switch should be done after the product is at consistency in “Serve Mode” or when the machine is empty.*

1. Open and close the spigot slowly. There should be a click when it opens and another when it closes.
2. The clicking sound should be within the first 1/2” of the spigot glide movement. If the switch does not close, an adjustment may be necessary.



#### WARNING

##### Hazardous voltage

The Main Freezer Power switch must be placed in the OFF position when disassembling for servicing. The machine must be disconnected from electrical supply before removing any access panel. Failure to disconnect power before servicing could result in death or serious injury.

### SPIGOT SWITCH TESTING - ELECTRICAL

1. Disconnect the switch from the circuit by unplugging the connector.
2. Check resistance readings across the common (COM) and normally closed (NC) terminals. When the spigot is closed, the resistance should show an open. When the spigot is opened, the switch will close and the resistance should be 0 ohms.

### SPIGOT SWITCH ADJUSTMENT

1. Place the Main Power OFF/ON switch and the Freezing Cylinder OFF/ON switch in the OFF position.
2. Remove the header panel.
3. Loosen the bolts on the spigot switch.
4. Using a pencil, mark the spigot glide 1/4” from the spigot housing.
5. Adjust the switch to activate when the plastic glide reaches the mark.
6. Fully tighten the retaining bolts and remove mark from spigot glide.

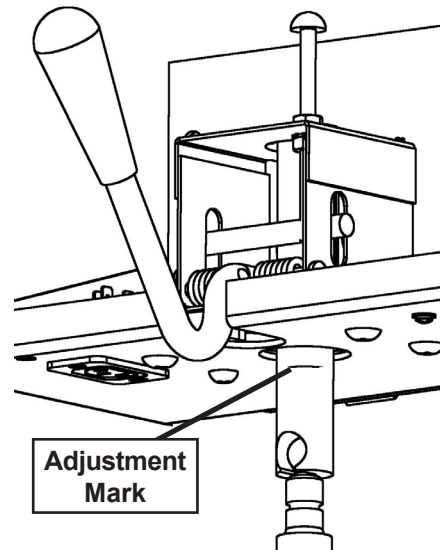

Figure 4-9 Spigot Switch Replacement

### SPIGOT SWITCH REPLACEMENT

1. Remove the header panel.
2. Remove the four bolts that attach the spigot cam assembly to the panel.

#### NOTE

*Hold the spring on the rear left bolt to prevent it from snapping back.*

3. Remove the assembly.

4. Disconnect the connector from the switch and remove the switch.
5. Install the replacement switch onto the handle assembly. Do not fully tighten the retaining screws at this time.
6. Using a pencil, mark the spigot glide 1/4" from the spigot housing. Adjust the switch to activate when the spigot handle moves the glide to the mark.
7. Fully tighten the retaining screws.
8. Attach the connector to the spigot switch.
9. Position the spigot handle assembly in the electrical box. Install the four bolts that attach the spigot cam assembly to the panel. Do not tighten the rear left bolt.
10. Thread the spring onto the rear left bolt using a needle nose pliers. Turn the bolt until the spring is threaded to the nut.
11. Tighten all bolts.
12. Replace the header panel and secure with the two Phillips head screws.

### B. BLENDER ACTIVATION SWITCH

The switch is a normally closed, held open switch. When the spigot is pulled to the right, the switch closes the circuit and starts the blender.

#### SWITCH TESTING - ELECTRICAL

1. Disconnect the switch from the circuit by unplugging the terminals.

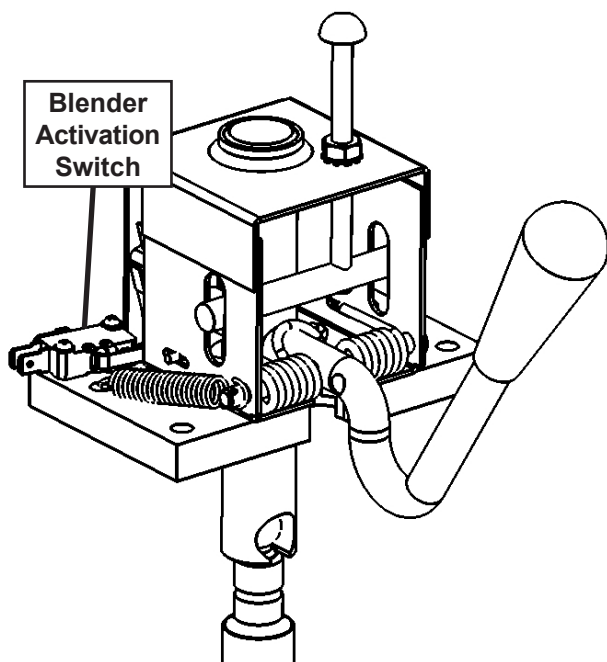

Figure 4-10 Blender Activation Switch

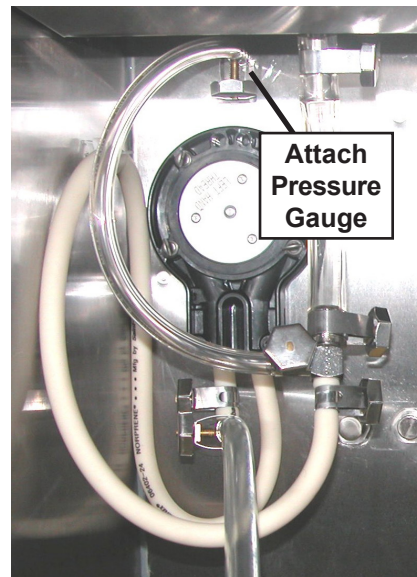

Figure 4-11 Attaching Gauge to Pump

2. Check resistance readings across the common (COM) and normally closed (NC) terminals. When the spigot is closed, the resistance should show an open. When the spigot is opened, the switch will close and the resistance should be 0 ohms.

#### SWITCH REPLACEMENT

1. Remove the header panel.
2. Disconnect the terminals from the switch and remove the switch.
3. Install the replacement switch onto the assembly

### C. PUMP PRESSURE SWITCH

The pump pressure switch maintains 21-24 psig in the mix line.

#### PUMP PRESSURE SWITCH TEST

1. Turn off the pump motor.
2. Open the spigot to relieve air pressure in the system.
3. Connect a gauge between the 1/4" ID tubing and pump outlet in the cab (Refer to Figure 4-11).
4. Turn on the pump motor.
5. The motor should cutout when the gauge reads 24 psig  $\pm$ 1.
6. Open the spigot and monitor the gauge. The motor should cutin when the gauge reads 21 psig  $\pm$ 1.

## 4.9 POTENTIAL RELAY

The potential relay senses voltage produced by the start winding. When the rated pick-up voltage is reached, the relay will open and drop the start capacitor from the circuit.

## 4.10 TEMPERATURE CONTROL SENSOR

The temperature control sensor is a thermistor used to sense the temperature of the suction line. As the suction line temperature increases, the internal resistance of the thermistor will decrease. Refer to Figure 4-12 for the relationship between sensor resistance and temperature. The IntelliTec control board monitors this value. In “Serve Mode”, when the temperature of the sensor equals the Cut In T value on the control, a freezing cycle will start.

## 4.11 SPINNER SPEED CONTROL HARNESS

The blender speed on the SU412 and STU412 machines is controlled by a wire harness behind the header panel.

There are two wire harnesses available. The blender speed of the wire harness in the SU412 is 1600 rpm and the wire harness in the STU412 is 2400 rpm.

To change blender speeds, replace the wire harness.

°F	Resistance	°F	Resistance
-22	176950	40	26100
-20	165200	42	24725
-18	154300	44	23400
-16	144200	46	22175
-14	134825	48	21000
-12	126125	50	19900
-10	118050	52	18875
-8	110550	54	17900
-6	103550	56	17000
-4	97075	58	16125
-2	91025	60	15325
0	85400	62	14550
2	80150	64	13825
4	75275	66	13150
6	70725	68	12500
8	66475	70	11875
10	62500	72	11300
12	58800	74	10750
14	55325	76	10250
16	52100	78	9750
18	49075	80	9300
20	46250	82	8850
22	43600	84	8450
24	41125	86	8050
26	38800	88	7675
28	36625	90	7325
30	34575	92	7000
32	32675	94	6675
34	30875	96	6375
36	29175	98	6100
38	27600	100	5825

Figure 4-12 Resistance Related to Temperature



## SECTION 5 TROUBLESHOOTING

### 5.1 ERROR CODES

When the machine experiences a problem, one of the following error codes will be displayed on the control panel. Each error code directs you to the system location of the malfunction.

#### ERROR CODE MALFUNCTION

1	Soft
2	High Torque
3	Extended Run Time
4	Clean
5	Barrel Sensor
6	Hopper Sensor
7	Drive Motor
8	Cab Sensor
9	High Pressure Cutout
10	Auxiliary Sensor
11	Low Temperature
12	Left Hopper Sensor
13	Right Hopper Sensor

To return the machine to normal operation, any error causing condition must be corrected and the Freezing Cylinder Off-On switch must be placed in the Off position and back in the On position before the affected side of the machine will return to normal operation.

### 5.2 TROUBLESHOOTING - ERROR CODES

#### Error Code 1 - Soft Error

The Soft Error (E1) is an internal control board error that is logged for future analysis. The refrigeration is never stopped and the machine will continue to operate normally.

#### Error Code 2 - High Torque

If the control panel displays a High Torque Error (E2), the controller has sensed that the drive motor is running at 125% of the preset CutOut amp setting for 10 or more seconds. Very low and/or fluctuating supply voltages typically cause this error. The error can also be caused by faulty motor or starting components which could produce a high amp draw.

#### Error Code 3 - Run Time

The Run Time Error (E3) occurs when the compressor runs continuously for 20 minutes without the product reaching consistency in "Serve Mode" or if the product does not reach proper temperature in "Sleep 2 Mode". This error is generally caused by very low mix levels in the machine's mix container or from product

breakdown. Another common cause results from a restriction preventing mix from entering the freezing cylinder. Check the mix in the cabinet. If the level mix is low, add mix. If there is a possibility that the mix is broken down, clean and sanitize the machine and replace the mix with fresh product.

Ice crystals in the liquid mix container can clog the mix inlet system and prevent mix from entering the freezing cylinder. Thoroughly thaw mix per manufacturer's recommendations. To check for ice crystals, pour a small amount of product in the mix container through a clean and sanitized sieve or strainer. If ice crystals are in the mix, check the temperature of the machine's cabinet.

Check the condition of the neoprene hose running through the mix pump head. If it shows signs of wear, rotate or replace it as outlined in Section 3.

In air cooled machines, the Run Time Error may indicate that airflow within the machine has reduced or stopped. Check the sides and top of the machine for anything that would restrict airflow.

The Run Time Error may also occur if airflow within the machine has reduced or stopped. Check the sides and top of the machine for anything that would restrict airflow. Check the condenser filter and clean if necessary. Check the evaporator for frost that could restrict airflow.

The compressor will run continuously if a solenoid valve fails to open. This could be due to loose wiring, magnetic coil failure, a stuck valve or a faulty control board.

After the cause of the problem is found and remedied place the Freezing Cylinder Off-On switch in the Off position and back in the On position.

#### Error Code 4 - Clean

If the machine is left in the Clean Mode for more than 20 minutes, the control panel will display a Clean Error (Error 04). This condition does not reflect a problem with the machine itself. The Clean Error has been programmed into the controller as a safeguard to protect the machine from potential damage caused by the machine being accidentally left in "Clean Mode". The control will attempt to restart itself after 5 minutes. The display will then flash and read Restart. To immediately clear the Clean Error, place the Main Power Off-On switch in the Off position and back in the On position. After restarting the machine, a refrigeration cycle will begin. This protects the product in case the clean button was pressed by mistake.

### Error Code 5 - Freezing Cylinder Sensor

The Freezing Cylinder Sensor Error (E5) indicates a failure of the barrel sensor or an extreme out of range condition (< -34°F or > 99°F). If the control panel displays an E5, place the Freezing Cylinder Off-On switch in the Off position and back in the On position. If the control panel still displays the error code, refer to the machine's wiring diagram and the Temperature Sensor Chart (Figure 5-1). Check each lead of the sensor to ground for continuity. If continuity is found, replace the sensor. To check the resistance of the sensor, place a thermocouple on the suction line at the exit of the freezing cylinder. Compare temperature and sensor resistance with the table as reference. If measured value does not coincide with a value on the table ( $\pm 400$  ohms), replace the sensor.

#### NOTE

*When the machine encounters a Freezing Cylinder Sensor Error, the machine will continue to run using preset timers. This mode will allow the operator to continue serving product until the machine can be serviced.*

°F	Resistance	°F	Resistance
-22	176950	40	26100
-20	165200	42	24725
-18	154300	44	23400
-16	144200	46	22175
-14	134825	48	21000
-12	126125	50	19900
-10	118050	52	18875
-8	110550	54	17900
-6	103550	56	17000
-4	97075	58	16125
-2	91025	60	15325
0	85400	62	14550
2	80150	64	13825
4	75275	66	13150
6	70725	68	12500
8	66475	70	11875
10	62500	72	11300
12	58800	74	10750
14	55325	76	10250
16	52100	78	9750
18	49075	80	9300
20	46250	82	8850
22	43600	84	8450
24	41125	86	8050
26	38800	88	7675
28	36625	90	7325
30	34575	92	7000
32	32675	94	6675
34	30875	96	6375
36	29175	98	6100
38	27600	100	5825

**Figure 5-1 Temperature Sensor Resistance (10K Ohms)**

### Error Code 6 - Hopper Sensor (single hopper machines)

The Hopper Sensor Error (E6) will not occur on the U412 or SU412 machines.

### Error Code 7 - Drive Motor

If the control panel displays a Drive Motor Error (E7), the control does not sense current coming from the drive motor. Place the Freezing Cylinder Off-On switch in the Off position and back in the On position. If the error returns, use the machine's wiring diagram and check connections at the IntelliTec control and at the motor. An E7 may also be the result of a faulty drive motor contactor.

### Error Code 8 - Cab Sensor

A Cab Sensor Error (E8) indicates a cabinet temperature sensor failure or. This error will also appear in an extreme out of range condition (< -34°F or > 99°F). If the control panel displays an E8, place the Freezing Cylinder Off-On switch in the Off position and back in the On position. If the control panel still displays the error condition code, refer to the wiring diagram and the temperature sensor value table. Check each lead of the sensor to ground for continuity. If continuity is found, replace the sensor. Place a thermocouple in the cabinet evaporator discharge airstream (outlet air flow). Compare temperature to sensor resistance using the table as reference. If Cutin/Cutout values do not coincide with the values on the table, replace the sensor..

### Error Code 9 - High Pressure Cutout

High Pressure Cutout Errors (E9) are usually caused by a dirty or inefficient condenser.

In air cooled condenser models, check for proper air clearance around the machine.

In water cooled condenser models check for proper water flow.

If the error persists, contact your Authorized Stoelting Distributor for further assistance.

### Error Code 10 - Auxiliary Sensor

An Auxiliary Temperature Sensor Error (E10) occurs if the temperature sensor on the control board fails. Place the Freezing Cylinder Off-On switch in the Off position and back in the On position. After the cause of the error is determined and corrected, place the Freezing Cylinder Off-On switch in the Off position and back in the On position.

### Error Code 11 - Low Temperature

The Low Temperature Error (E11) occurs when the temperature of the gas refrigerant at the freezing cylinder sensor falls below -20°F. Although the machine will not shut down, the active freezing cycle will immediately end. This error usually occurs when the machine continues to run in a low mix condition or if the machine runs out of mix. The product towards the front of the freezing cylinder tends to freeze solid. When the temperature on the freezing cylinder lowers to the preset value, the IntelliTec control will display an E11.

### Error Code 12 - Hopper Sensor

The Left Hopper Sensor Error (E12) will not occur on the U412 or SU412 machines.

### Error Code 13 - Hopper Sensor

The Right Hopper Sensor Error (E13) will not occur on the U412 or SU412 machines.

### COMMO TIMEOUT Error

A COMMO TIMEOUT Error indicates a communication interruption between the display and the control board. This error can be caused by a poor connection or a faulty phone cable. Disconnect and reconnect the telephone cable at the control board. If the error does not clear, disconnect and reconnect the telephone cable at the display panel module. If the error still appears, the cable may be faulty or the display panel module may be faulty.

### ALTERNATING FLASHING CONTROL PANEL LIGHTS

The display panel lights will flash in an alternating sequence under any error codes. Clear the error and place the Freezing Cylinder Off-On switch in the Off position and back in the On position.

The alternating lights will also illuminate if the Main Power switch is in the On position and the Freezing Cylinder switch is in the Off position.

### 5.3 TROUBLESHOOTING - MACHINE

PROBLEM	POSSIBLE CAUSE	REMEDY
<b>Drive motor (auger) “kicks-out”, or does not run.</b>	<ol style="list-style-type: none"> <li>1. Power to machine is off.</li> <li>2. Low line voltage.</li> <li>3. Product too hard.</li> <li>4. Front door not installed securely.</li> </ol>	<ol style="list-style-type: none"> <li>1. Check power to machine.</li> <li>2. Check, must be <math>\pm 10\%</math> of nameplate voltage.</li> <li>3. Raise overrun. (See Section 4)</li> <li>4. Install front door securely.</li> </ol>
<b>Compressor does not operate.</b>	<ol style="list-style-type: none"> <li>1. Power to machine is off.</li> <li>2. Low line voltage.</li> <li>3. Compressor internal overload is cut-out.</li> <li>4. Front door not installed securely.</li> </ol>	<ol style="list-style-type: none"> <li>1. Check power to machine.</li> <li>2. Check, must be <math>\pm 10\%</math> of nameplate voltage.</li> <li>3. Check condenser (air cooled)(See Sect. 4), or water supply (water cooled).</li> <li>4. Install front door securely.</li> </ol>
<b>Product too soft.</b>	<ol style="list-style-type: none"> <li>1. CutOut setting is too low</li> <li>2. Product break down.</li> </ol>	<ol style="list-style-type: none"> <li>1. Adjust CutOut setting to match product requirements.(See Section 3)</li> <li>2. Fill with fresh product.</li> </ol>
<b>Freeze-up. (Product will not dispense easily.)</b>	<ol style="list-style-type: none"> <li>1. CutOut setting is too high.</li> <li>2. Low overrun setting.</li> <li>3. Low pump pressure.</li> <li>4. Large air pocket in barrel.</li> <li>5. Auger turning counter-clockwise.</li> </ol>	<ol style="list-style-type: none"> <li>1. Adjust CutOut setting to match product requirements.(See Section 3)</li> <li>2. Raise overrun. (See Section 4)</li> <li>3. Check pump pressure.</li> <li>4. Purge air from barrel.</li> <li>5. Change rotation to clockwise.</li> </ol>
<b>Rear auger seal leaks.</b>	<ol style="list-style-type: none"> <li>1. Seal missing or installed wrong.</li> <li>2. Rear seal o-ring missing, broken or not lubricated.</li> <li>3. Worn or scratched shaft.</li> </ol>	<ol style="list-style-type: none"> <li>1. Install correctly. (See Section 3)</li> <li>2. Inspect for breakage and lubricate properly (See Section 3)</li> <li>3. Replace shaft.</li> </ol>
<b>Spigot leaks.</b>	<ol style="list-style-type: none"> <li>1. Spigot parts are not lubricated.</li> <li>2. Chipped or worn o-rings.</li> <li>3. O-rings on spigot installed wrong.</li> <li>4. Nicks or scratched on front door where spigot is located.</li> </ol>	<ol style="list-style-type: none"> <li>1. Lubricate. (See Section 3)</li> <li>2. Replace o-rings.</li> <li>3. Remove spigot and check o-rings.</li> <li>4. Replace front door.</li> </ol>
<b>Drive belts slipping or squealing.</b>	<ol style="list-style-type: none"> <li>1. Drive belt tension not correct.</li> <li>2. Worn belt(s).</li> <li>3. Low overrun.</li> </ol>	<ol style="list-style-type: none"> <li>1. Adjust belt tension. (See Section 4)</li> <li>2. Replace belts.</li> <li>3. Check for air leak.</li> </ol>
<b>Mix temperature too warm in cab.</b>	<ol style="list-style-type: none"> <li>1. Temperature control set too warm.</li> <li>2. Cab door is open.</li> </ol>	<ol style="list-style-type: none"> <li>1. Decrease CabCtOut and CabCutIn (See Section 4)</li> <li>2. Close the cab door.</li> </ol>
<b>Mix temperature too cold in cab.</b>	<ol style="list-style-type: none"> <li>1. Temperature control set too cold.</li> </ol>	<ol style="list-style-type: none"> <li>1. Increase CabCtOut and CabCutIn (See Section 4)</li> </ol>

## 5.4 TROUBLESHOOTING - MIX PUMP

PROBLEM	POSSIBLE CAUSE	REMEDY
<b>Pump motor does not run.</b>	<ol style="list-style-type: none"> <li>1. Power to pump is off.</li> <li>2. Low voltage.</li> <li>3. Mix pump hose jammed inside black cover/clamp.</li> <li>4. Pump motor overloaded.</li> <li>5. Pressure switch on pump is defective.</li> <li>6. Defective motor/capacitor.</li> <li>7. Defective toggle switch.</li> </ol>	<ol style="list-style-type: none"> <li>1. Supply power to pump.</li> <li>2. Check for low voltage.</li> <li>3. Disconnect pump from power source. Remove four cover/clamp thumb screws. Separate cover/clamp halves and remove outer half. Remove jammed hose. Clean and re-install cover/clamp and tighten four thumb screws securely. Allow motor thermal overload to reset.</li> <li>4. Allow internal thermal overload to reset; determine overload cause and repair.</li> <li>5. Check mechanical operation and continuity of pressure switch.</li> <li>6. Check motor amperage draw and/or capacitor. Replace motor or capacitor.</li> <li>7. Check continuity; repair or replace.</li> </ol>
<b>Pump operates but cylinder will not fill.</b>	<p>Note 1: A properly working pump will fill an 8 oz. cup with mix in about 9 seconds.</p> <p>Note 2: Immediately after a bag change the pump may be unable to reestablish it's prime with the system at operating pressure. In this case, turn the pump off. Draw 2-3 pints to reduce system pressure to zero. Turn pump on. Purge remaining air in mix bag and pick-up hose.</p> <p><b>Important: before connecting the pick-up hose to the mix bag, remove as much air from the mix bag as possible.</b></p>	
	<ol style="list-style-type: none"> <li>1. Out of Mix.</li> <li>2. Mix pump hose kinked inside black cover/clamp.</li> <li>3. Hoses assembled incorrectly.</li> <li>4. Mix pump hose service life is exceeded.</li> <li>5. Mix pump hose not connected to machine.</li> <li>6. Ice crystals in mix.</li> <li>7. Mix bag drawn against adapter.</li> <li>8. Foreign objects in mix.</li> <li>9. Check valve is backwards.</li> </ol>	<ol style="list-style-type: none"> <li>1. Replenish mix supply.</li> <li>2. Disconnect pump from power source. Remove four cover/clamp thumb screws. Separate cover/clamp halves and remove outer half. Remove jammed hose. Clean and re-install cover/clamp and tighten four thumb screws securely. Allow motor thermal overload to reset.</li> <li>3. Refer to diagram for correct hose connections.</li> <li>4. Reposition/replace mix pump hose. See Section 4.9</li> <li>5. Connect mix pump hose to machine.</li> <li>6. Completely thaw mix prior to use.</li> <li>7. Ensure bag is clear of pick-up tube.</li> <li>8. Clear blockage. Use fresh mix.</li> <li>9. Observe flow arrow for proper orientation.</li> </ol>
<b>Overrun too low or no overrun.</b>	<ol style="list-style-type: none"> <li>1. Overrun setting too low.</li> <li>2. Air leak.</li> <li>3. Air compressor not pumping air.</li> <li>4. Air check valve in backwards.</li> </ol>	<ol style="list-style-type: none"> <li>1. Increase overrun setting.</li> <li>2. Tighten all hose clamps.</li> <li>3. Contact local Stoelting Distributor.</li> <li>4. Check arrow for direction of flow.</li> </ol>

PROBLEM	POSSIBLE CAUSE	REMEDY
<b>Overrun too high.</b>	<ol style="list-style-type: none"> <li>Mix pump hose service life is exceeded.</li> <li>Out of mix.</li> <li>Overrun setting too high.</li> <li>Pick-up leg of mix pump hose is collapsing.</li> </ol>	<ol style="list-style-type: none"> <li>Reposition/replace mix pump hose.</li> <li>Replenish mix supply.</li> <li>Decrease overrun setting.</li> <li>Reposition hose.</li> </ol>
<b>Replacement mix pump hose won't feed through pump.</b>	<ol style="list-style-type: none"> <li>Feeding hose into discharge hole of mix pump cover.</li> <li>Hose ends not cut squarely.</li> <li>Force feeding too quickly.</li> <li>Pump motor not running.</li> </ol>	<ol style="list-style-type: none"> <li>Feed hose into suction side of cover.</li> <li>Carefully cut hose end off squarely (no tails).</li> <li>Gently and slowly assist feeding of hose up into pick-up hose side of cover.</li> <li>Turn on motor switch.</li> </ol>
<b>Air exiting mix pick-up hose.</b>	<ol style="list-style-type: none"> <li>Pickup tube check valve missing.</li> </ol>	<ol style="list-style-type: none"> <li>Contact local Stoelting Distributor.</li> </ol>
<b>Dispensed product air "pops"</b>	<ol style="list-style-type: none"> <li>Overrun setting too high.</li> <li>Mix pump hose service life is exceeded.</li> <li>Overdrawing the machine's capacity.</li> <li>Recent low mix condition.</li> </ol>	<ol style="list-style-type: none"> <li>Decrease overrun setting.</li> <li>Reposition/replace mix pump hose.</li> <li>Reduce dispense rate.</li> <li>Open spigot fully and allow excess air to escape.</li> </ol>
<b>Mix leakage from pump.</b>	<b>CAUTION: To prevent mix pump damage from dried mix deposits, immediately disassemble and clean pump.</b>	
	<ol style="list-style-type: none"> <li>Mix pump hose service life is exceeded.</li> </ol>	<ol style="list-style-type: none"> <li>Remove mix pump hose. Disconnect pump from power source. Remove mix pump cover/clamp. Clean the rollers a small amount of soapy water. Clean mix from pump. See Section 4.2 for hose replacement.</li> </ol>
<b>Pump is noisy/squeaking.</b>	<p>Note: The action of the air compressor rocking arm creates a repetitive clicking sound during operation. This is normal.</p> <p>Note: The peristaltic mix pump has three squeeze rollers that use self lubricating bearings. If squeaking exists with the mix pump hose in place and stops with the hose removed, the squeeze roller bearings can be lubricated using a silicone based spray. Remove the mix pump hose. Disconnect pump from electrical power. Remove four cover/clamp thumbscrews. Remove entire cover/clamp as one unit. Spray silicone based lubricant on each end of each squeeze roller. Spin rollers to work lubricant into bearings. Repeat as needed.</p> <p><b>Caution: Do not use cleaning/dissolving type lubricants like wd-40. These lubricants are not bearing friendly and will accelerate bearing wear.</b></p>	
<b>Mix in air hoses.</b>	<ol style="list-style-type: none"> <li>Air/mix tee above black cover/clamp.</li> <li>Air leak.</li> <li>Mix hose on wrong air/mix tee fitting.</li> <li>Pressure control manifold o-ring leak.</li> </ol>	<ol style="list-style-type: none"> <li>Air/mix tee must be below black cover/clamp.</li> <li>Tighten all hose clamps.</li> <li>Refer to diagram for correct hose connections.</li> <li>Check o-ring and manifold; replace as required.</li> </ol>

## SECTION 6 REPLACEMENT PARTS

### 6.1 AUGER & FRONT DOOR PARTS

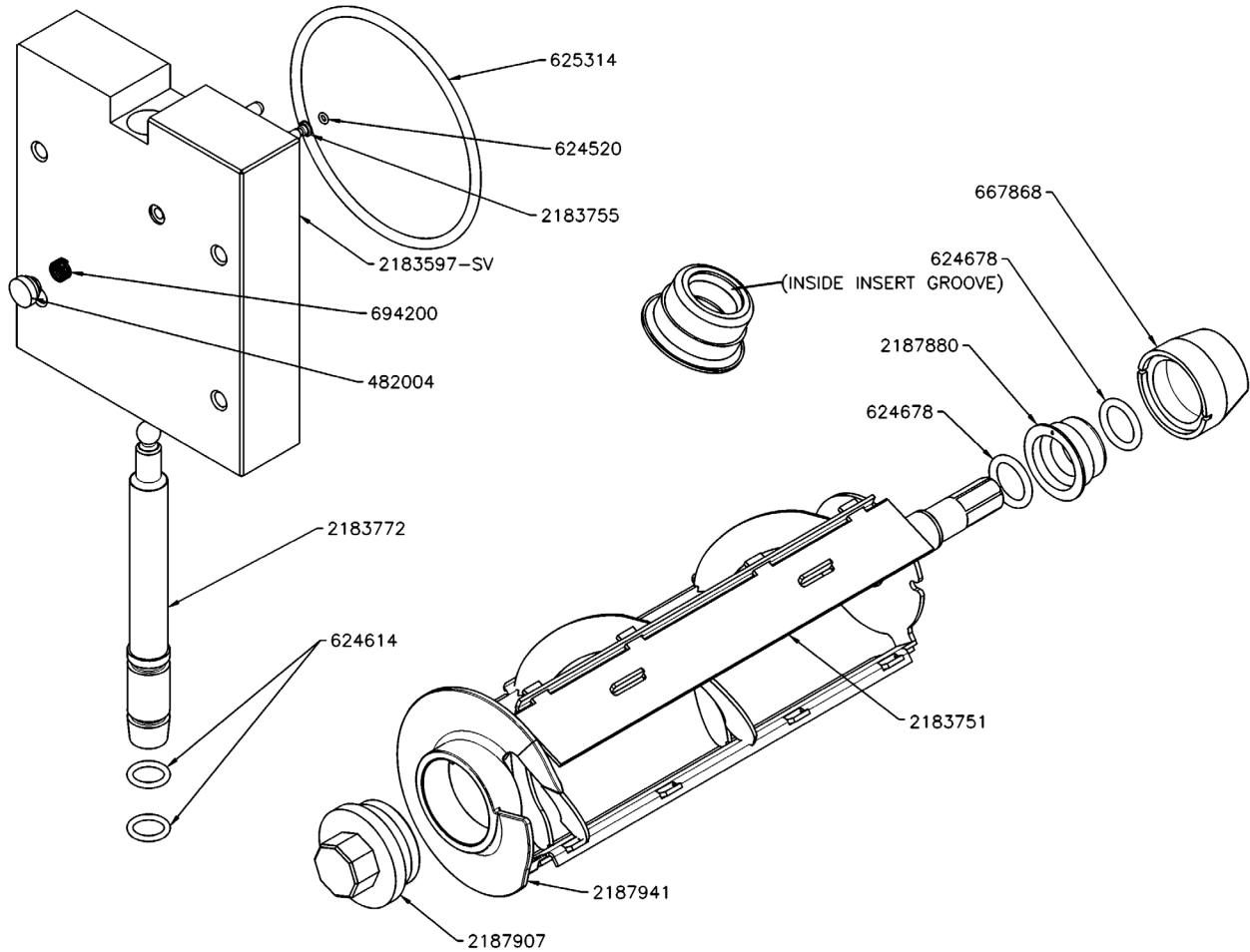

Part Number	Description	Quantity
162155	Scraper Blade (6.875" Long)	2
482004	Knob (Air Bleed Valve)	1
482019	Knob - Front Door (Black)	4
624520	O-Ring - Air Bleed Valve - Black	2
624614	O-Ring - Spigot - Black	2
624678	O-Ring - Rear Seal - Black	2
625314	O-Ring - Front Door - Black	1
667868	Seal - Rear Auger (Orange)	1
694200	Spring - Air Bleed Valve	1
2183597-SV	Front Door w/Pins & Air Bleed Valve	1
2183751	Scraper Blade (13.875" Long)	1
2183755	Valve - Air Bleed	1
2183772	Spigot Body	1
2187880	Adapter - Rear Seal (Two O-Ring Style)	1
2187907	Bushing - Front Auger Support	1
2187941	Auger Shaft	1

## 6.2 BLENDER PARTS & TRAYS

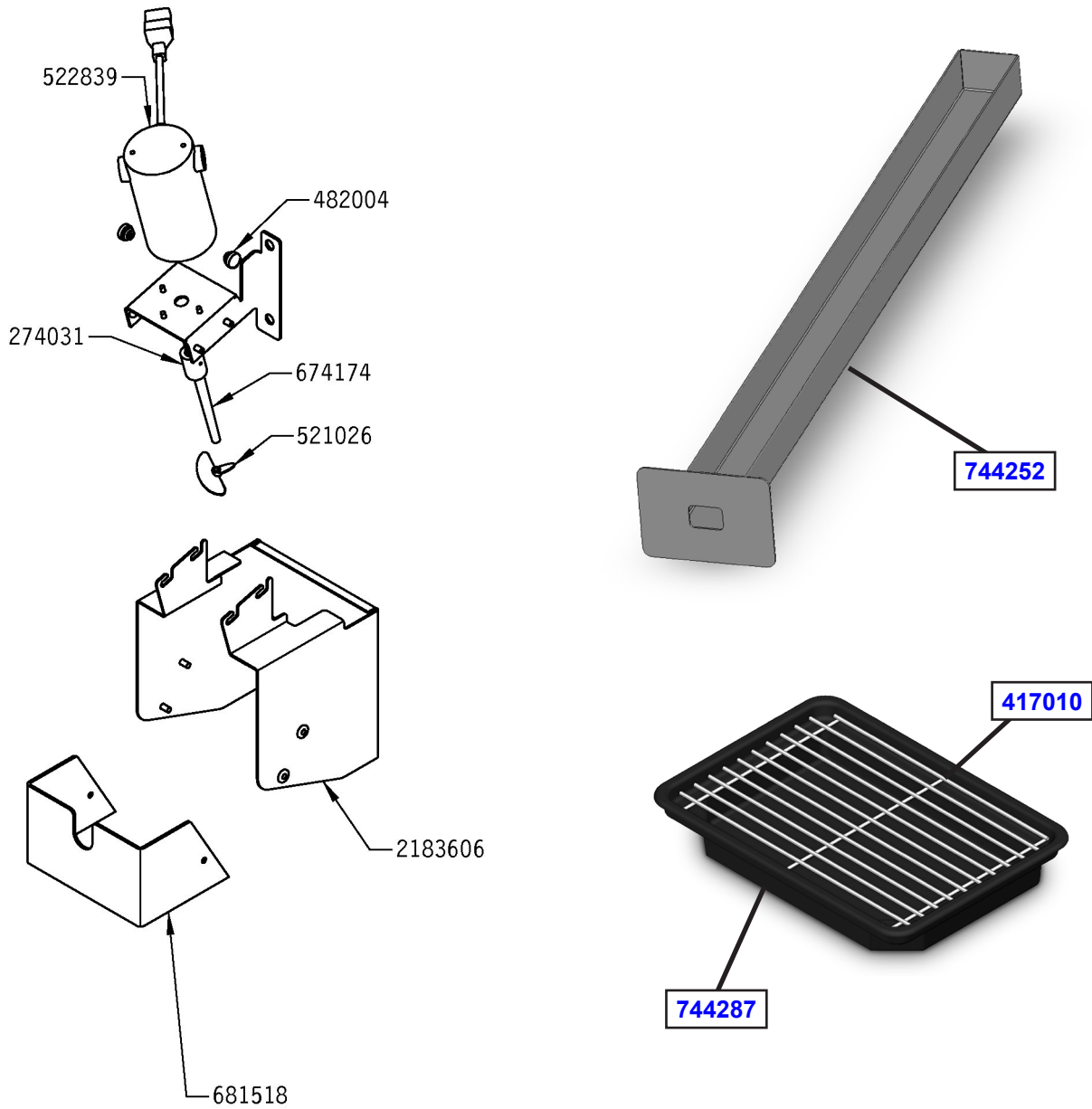

Part Number	Description	Quantity
274031	Blender Agitator Collar (SU412)	1
417010	Grid - Drip Tray	1
521026	Blender Agitator (SU412)	1
522839	Blender Motor (SU412)	1
674147	Blender Shaft (5") (SU412)	1
674174	Blender Shaft (7.6") (SU412)	1
674183	Blender Shaft (6.6") (SU412)	1
681518	Shield - Plastic Swing (SU412)	1
744252	Tray - Drain (Rear)	1
744287	Tray - Drip	1
2183606	Splash Shield Bracket (SU412)	1

### 6.3 CAB TUBING ASSEMBLY

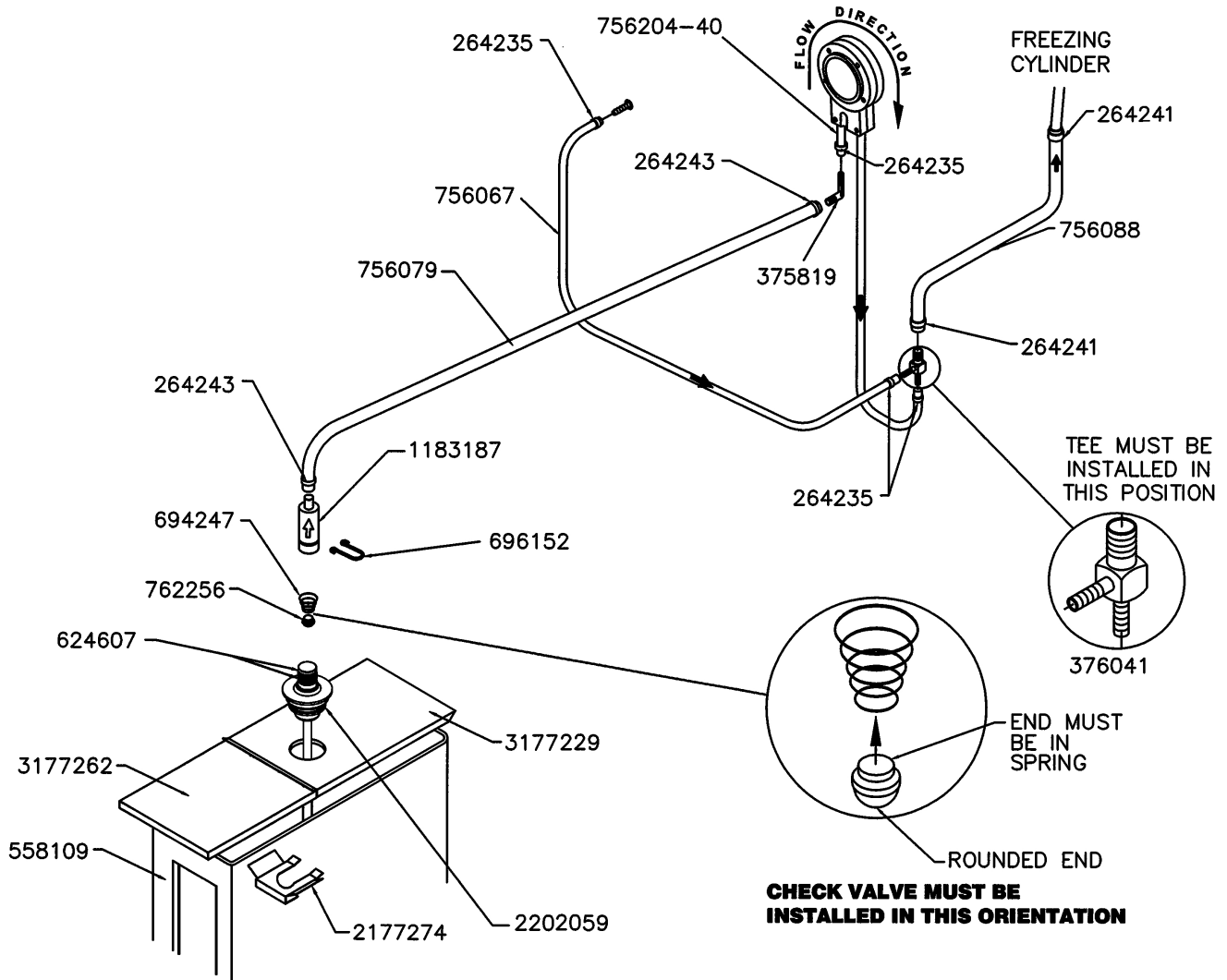

Part Number	Description	Quantity
264235	Clamp - Metal (1/4" ID Tubing) (Cab)	4
264241	Clamp - Metal (1/2" ID Tubing) (Cab)	2
264243	Clamp - Metal (3/8" ID Tubing) (Cab)	2
375819	Elbow - Barbed (3/8" - 1/4") (Cab)	1
376041	Tee Connector - 3-Way (Stainless) (Cab)	1
558109	Mix Container Only (Cab)	1
624607	O-Ring - Check Valve Body - Black (Cab)	2
694247	Spring - Cone (Cab Check Valve)	1
696152	Clip - Lock (Check Valve) (Cab)	3
756067	Tubing - 1/4" ID - Clear - Air Line (25' Increments) (Per Inch)	13"
756079	Tubing - 3/8" ID - Clear - Mix Line (25' Increments) (Per Inch)	24"
756088	Tubing - 1/2" ID - Clear - Mix Line (25' Increments) (Per Inch)	6"
756204	Tubing - 1/4" ID - Pump (50' Box Only) (Per Inch) (Cab)	-
756204-40	Tubing - 1/4" ID - Pump (Pre-Cut 40" Piece) (Cab)	4
762256	Check Valve - Mix Outlet (Cab)	1
1183187	Check Valve - Mix In Line (Outer) (Cab)	1
2177274	Clip - Retaining (Mix Probe To Cover) (Cab)	1
2202059	Pick-Up Tube - Mix (Cab)	1
3177229	Cover - Rear (Mix Container) (Cab)	1
3177262	Cover - Front (Mix Container) (Cab)	1

## 6.4 SPIGOT CAM ASSEMBLY

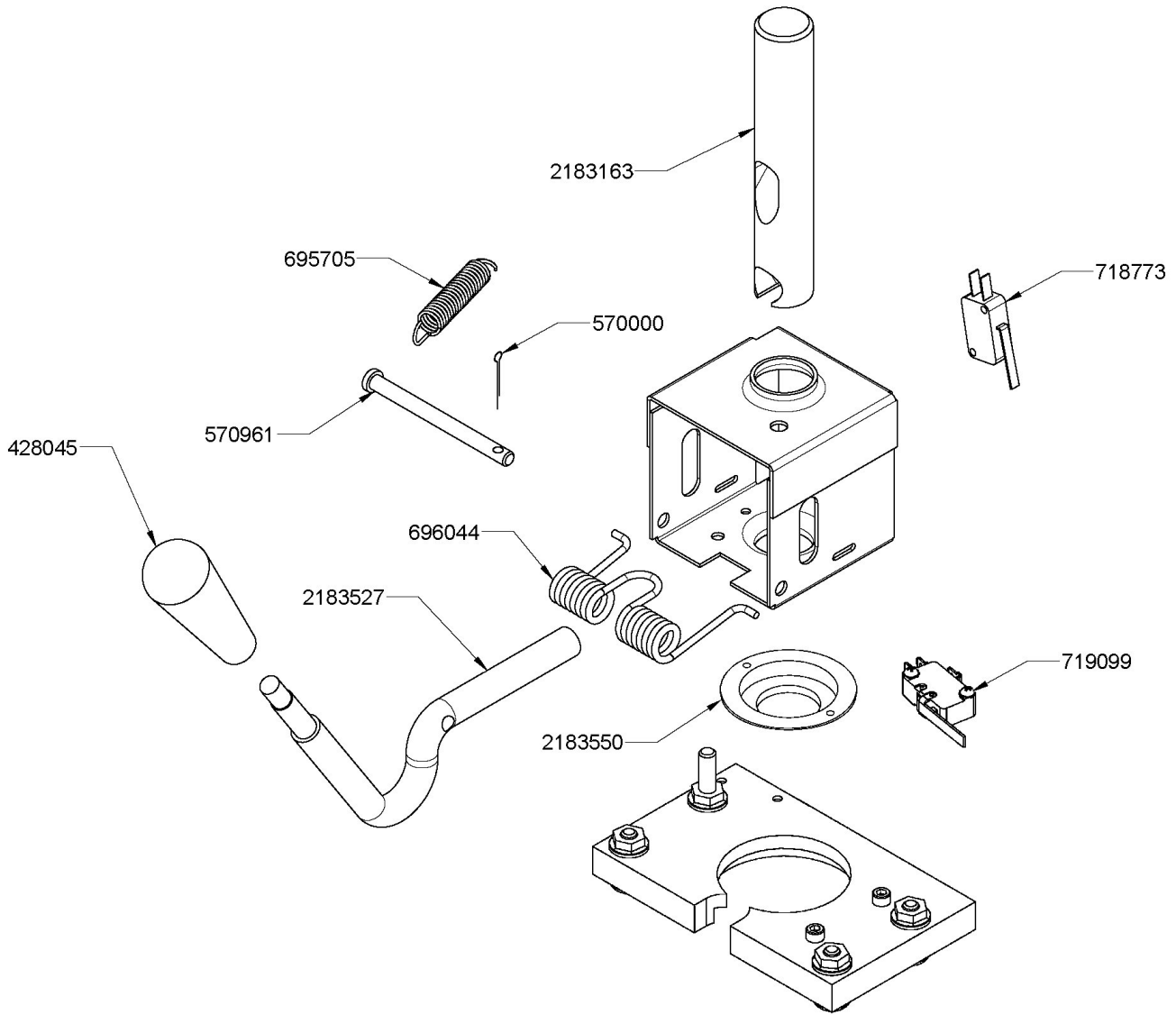

Part Number	Description	Quantity
428045	Knob - Spigot Handle (Black)	1
570000	Pin - Cotter (Spigot Cam)	1
570961	Pin - Cotterless Clevis (Spigot Cam)	1
695705	Spring - Blender Activation (SU412)	1
696044	Spring - Torsion (Spigot Cam)	3
718773	Switch - Spigot Cam	1
719099	Switch - Limit (Spinner) (SU412)	1
2183163	Glide - Spigot Socket (SU412)	1
2183527	Handle - Spigot (SU412)	1
2183550	Collar - Spigot (SU412)	1

## 6.5 FRONT PANEL



Part Number	Description	Quantity
332541	Board - Display Module (Display Only)	1
493041	Indicator Light (Cab On - Off)	1
718895	Switch - Rocker (Cab On-Off)	1
719025-SV	Switch - Membrane Strip	1

## 6.6 PART KITS

Part Number	Description	Quantity
128295	Rocker Arm Assembly w/Screw (Cab)	1
128296	Piston & Cylinder Sleeve Assembly (Cab)	1
1177436	Air Compressor Kit (Reed Valve, Piston & Cylinder Sleeve) (Cab)	-
2171962	Sensor Probe Kit	-
2187209	O-Ring & Bearing Kit (Ser. #0-28560)	-
<b>2177917</b>	<b>Brush Kit</b>	-
208135	Brush - 4" x 8" x 16" (Barrel)	1
208380	Brush - 1/4" x 3" x 14"	1
208387	Brush - 1/2" x 5" x 24"	1
208401	Brush - 1" X 3" X 10"	1
208465	Brush - 1" x 3-1/2" x 18"	1
208467	Brush - 3/8" x 1" x 5"	1
<b>2187979</b>	<b>O-Ring Kit (Ser. #28561 Plus)</b>	-
624520	O-Ring - Air Bleed Valve - Black	1
624607	O-Ring - Check Valve Body - Black (Cab)	2
624614	O-Ring - Top & Bottom Spigot - Black	2
624678	O-Ring - Rear Seal - Black	1
625314	O-Ring - Front Door - Black	1

## 6.7 PUMP PARTS

Part Number	Description	Quantity
150809	Belt (Cab)	1
369037	Fitting - Flared Brass - Air Inlet (Cab)	1
376035	Tee Connector - Air Pressure Switch (Cab)	1
432003-SV	Valve Head Only w/Tubes (Pump) (Cab)	1
522229	Motor - Pump (Cab)	1
538306	Nut - Motor Mounting (Cab)	4
598025	Pulley - Large (Cab)	1
644065	Screw - Rocker Arm (Cab)	1
650146	Set Screw - Pulley (Cab)	1
652412	Screw - Shoulder (Crank Arm Roller Assembly) (Cab)	1
653042	Screw - Thumb (Cover Clamp) (Cab)	4
667896	Seal - Bumper (Piston) (Cab)	1
717937	Switch - Pressure (Pump) (Cab)	1
762246	Check Valve - Air Line (Stainless) (Cab)	1
766058	Washer - Lock - Motor Mounting (Cab)	4
1171860	Spring - Check Valve (Pump) (Cab)	1
1171861-SV	Needle Valve w/O-Ring (Pump) (Cab)	1
1171862	Screw - Air Filter Retainer (Cab)	1
1171863	Valve Guide (Pump) (Cab)	1
1171864	O-Ring - Needle Valve (Pump) (Cab)	1
1171866	Screw - Valve Head (Cab)	5
1171867	O-Ring (Pump Cylinder Sleeve) (Cab)	1
1171868	Reed Valve (Pump) (Cab)	1
1171870	Cylinder Sleeve (Pump) (Cab)	1
1171871	Spring - Piston (Cab)	1
1171872	Piston Spring Seat (Cab)	1
1171873	Piston (Pump) (Cab)	1
1171874	Ball Bearing - Single (Pump Rocker Arm) (Cab)	1
1171955	Set Screw - Eccentric (Cab)	1
1171956	Washer - Crank Arm - Nylon (Cab)	1
1171958	Filter - Air (Pump) (Cab)	1
1171959	O-Ring (Piston) (Pump) (Cab)	1
1171977	Roller (Crank Arm) (Cab)	1
1171978	Screw - Crank Arm (Cab)	1
1171979	Crank Arm (Cab)	1
1171981	Eccentric (Cab)	1
1171982	Knob - Crank Arm Overrun Setting (Cab)	1
1171983	Dial - Crank Arm Overrun Setting (Cab)	1
1171984	Pointer - Crank Arm Overrun Setting (Cab)	1
1171985	Dowel Pin - Rocker Arm (Cab)	1
1171986	Flange Bearing - Rocker Arm (Cab)	2
1171987	Wick - Rocker Arm (Cab)	1
1171988	Collar - Rocker Arm Dowel Pin (Cab)	1
1171989	Pulley - Small (Pump) (Cab)	1
1171994	Sleeve Bearing - Crank Arm (Cab)	1
1177033	Bumper Ring (Piston) (Pump) (Cab)	1
1177034	Air Filter Retainer - Top (Cab)	1
1177035	Air Filter Retainer - Bottom (Cab)	1
1177036	Washer - Air Filter Retainer (Cab)	1
1177037	Screw - Air Filter (Cab)	1
1177681	Rocker Arm (Cab)	1
2177812	Roller Carrier Assembly Kit (Cab)	-
2183067	Pump Body Casting (Cab)	1
3171952	Cover - Clamp (Two Piece Black) (Cab)	1

## 6.7 PUMP PARTS (CONTINUED)

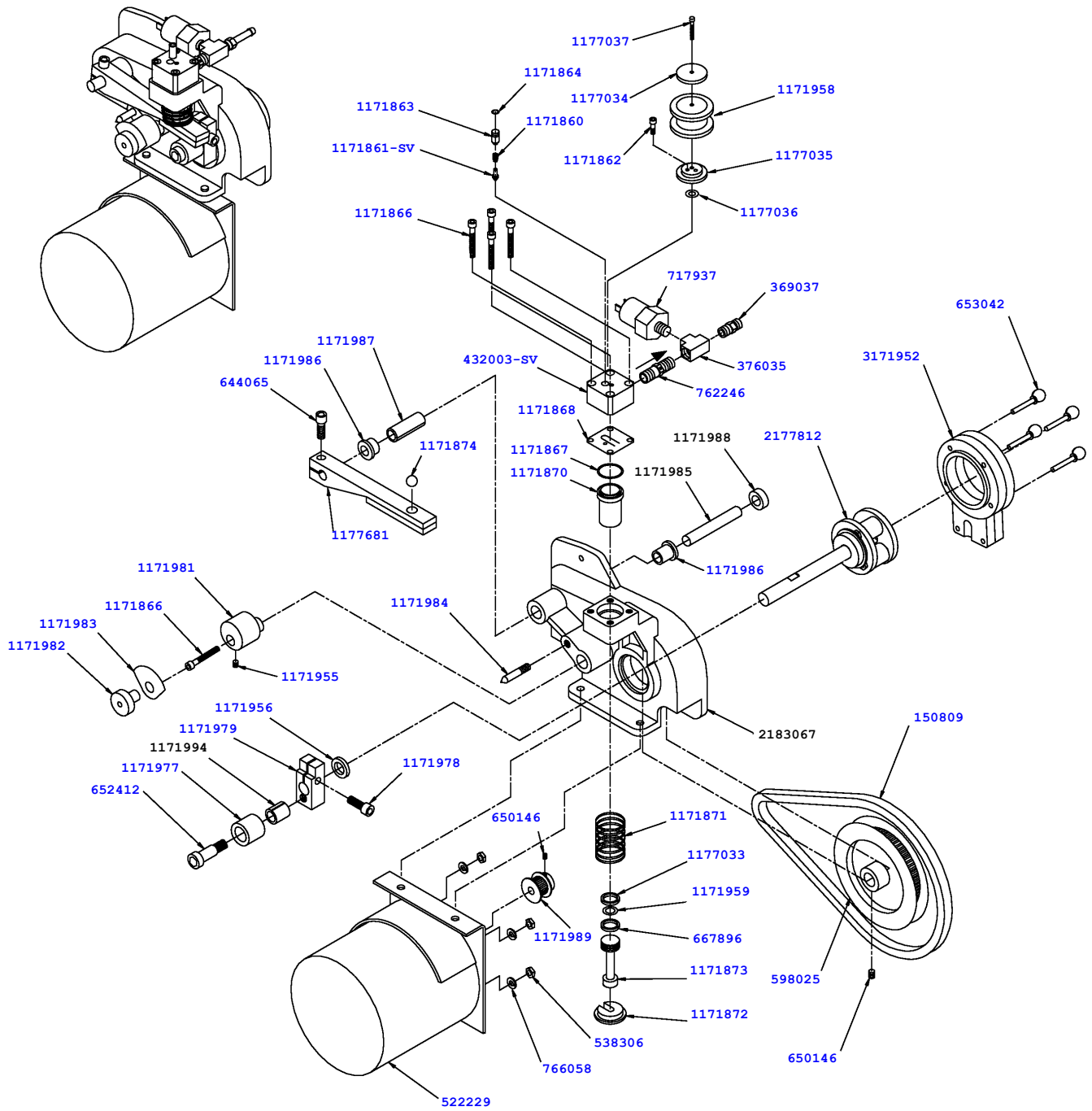

## 6.8 CAB INTERIOR

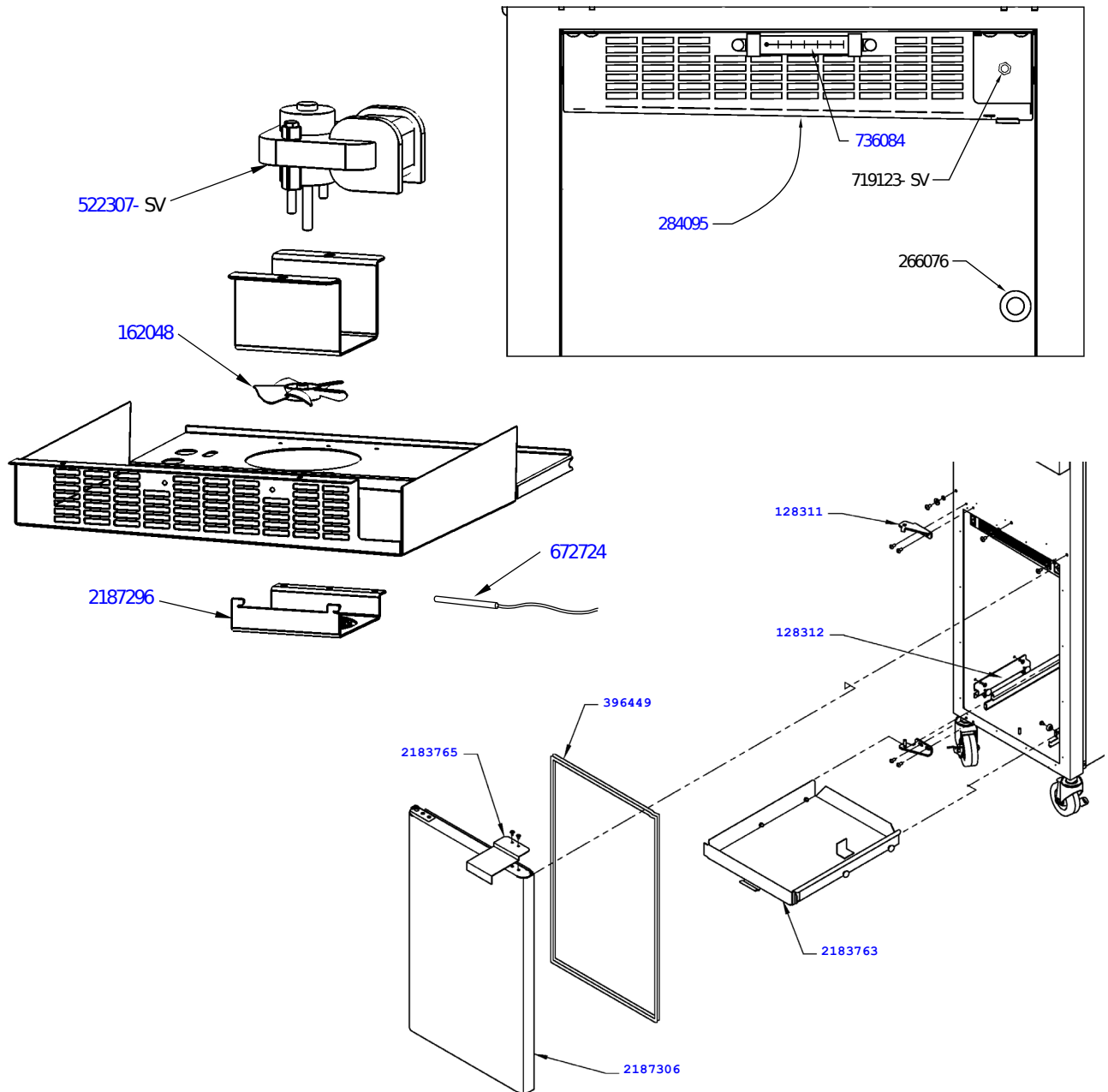

Part Number	Description	Quantity
128311	Hinge - Door (Top & Bottom) (Cab)	2
128312	Mix Container Holder Assembly w/Rollers (Cab)	1
162048	Blade - Fan (Evaporator) (Cab)	1
266018	Clip - "J" (Hose Holder) (Cab)	1
266076	Clip - Bag In Box (Cab)	2
284095	Evaporator (Cab)	1
396449	Gasket - Door (Cab)	1
522307-SV	Motor - Fan (Evaporator Assembly) (Cab)	1
672724	Sensor - Capacitive (Cab)	1
719123-SV	Switch - Pushbutton Door (Cab)	1
736084	Thermometer (Cab)	1
2183763	Mix Container Drawer (Cab)	1
2183765	Handle - Door (Cab)	1
2187296	Guard - Fan (Cab)	1
2187306	Door Assembly - Foamed (Cab)	1
2187931	Switch Kit - Cab Door (Hamlin Reed Switch) (Cab)	-

## 6.9 HEADER PANEL - ELECTRICAL

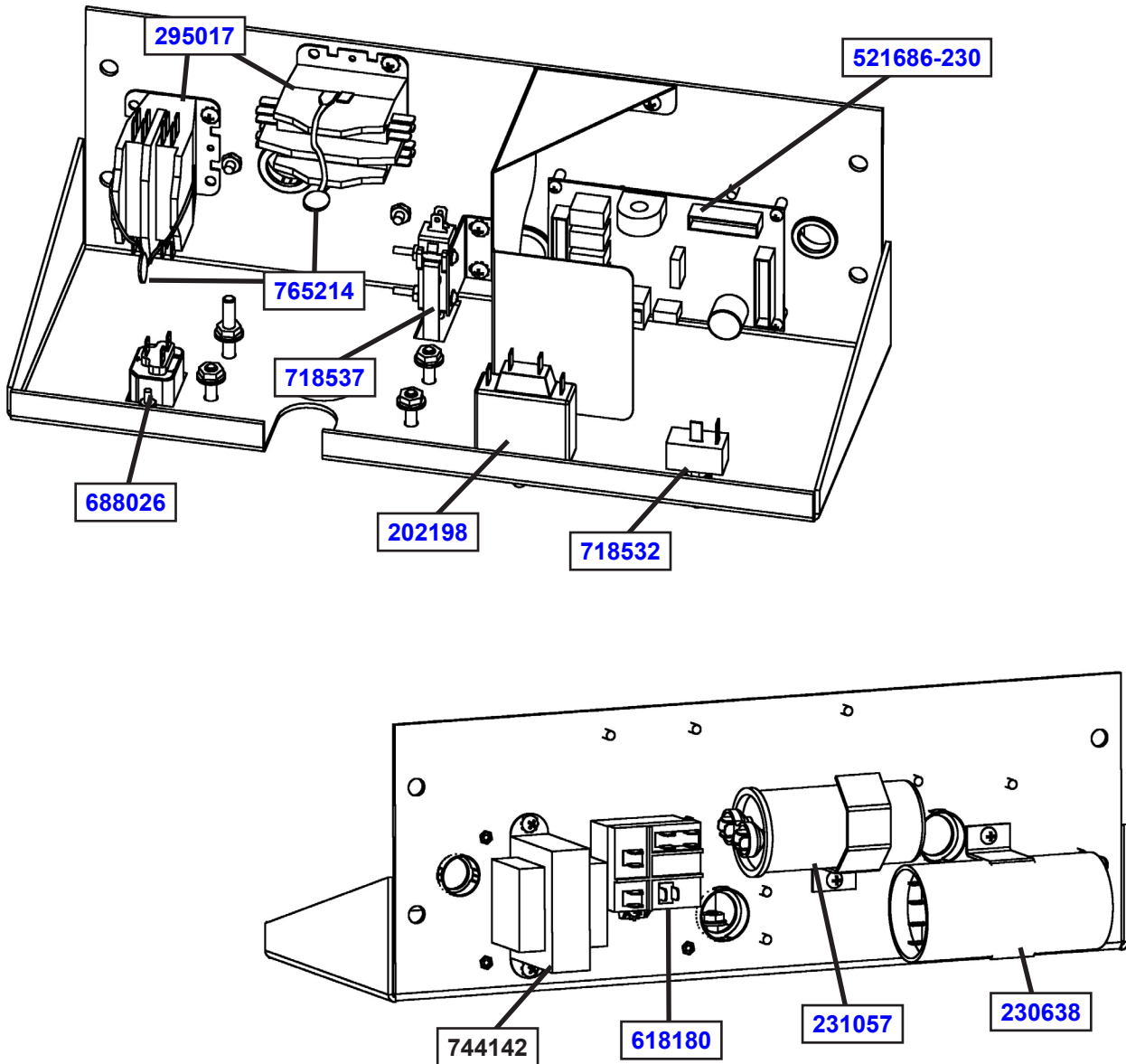

Part Number	Description	Quantity
202198	Switch - Blender Power & Reset (SU412)	1
229116	Cable - Phone (control Board to Display Board)	1
230638	Capacitor - Start (#282047 Compressor)	1
231057	Capacitor - Run (#282047 Compressor)	1
295017	Contactor (45CG20AG) (Drive Motor / Compressor / Cab)	2
521686-230	Program Board - IntelliTec (208V / 230V)	1
618180	Relay (Compressor)	1
688026	Blender Outlet Socket (SU412)	1
718532	Switch - Toggle (Freezing Cylinder On-Off )	1
718537	Switch - Limit (Door Interlock) & (SU412 - Blender Activation)	2
744142	Transformer	1
765214	Varistor Harness	4

## 6.10 LEFT-HAND SIDE

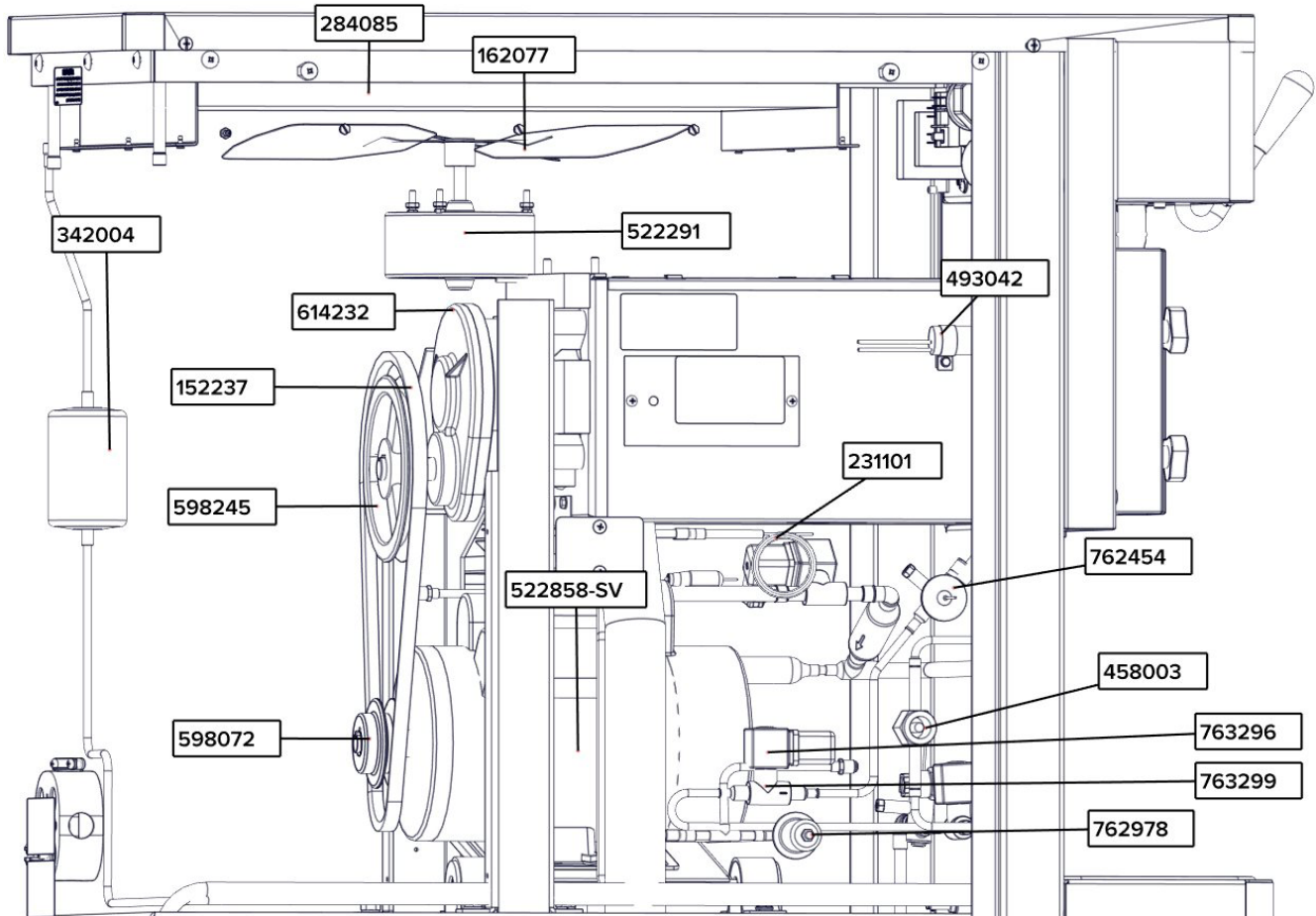

**Left-Hand Side Parts List**

Part Number	Description	Quantity
284085	Condenser (Air-Cooled)	1
342004	Drier (Liquid Line)	1
614232	Speed Reducer	1
152237	Belt - Gripnotch (AX35) (50 Hz) / (60 Hz Ser. #28561 Plus)	1
152245	Belt - V (4L350) (60 Hz) (Ser. #0- #28560)	1
598245	Pulley - Speed Reducer (60 Hz) (Ser. #0- #28560)	-
598072	Pulley - Drive Motor (60 Hz) (Ser. #0- #28560)	-
522858-SV	Motor - Drive (60 Hz)	1
522859	Motor - Drive (50 Hz)	-
762978	Valve - EPR (Cab)	1
763299	Valve - Solenoid (Liquid)	1
763296	Valve - Solenoid Coil (Liquid)	1
458003	Indicator - Liquid Line	1
762454	Valve - Expansion	1
231101	Cap Tube Only	1
493042	Flasher - Indicator Light (Cab On - Off)	1
522291	Motor - Fan (Air-Cooled Condenser)	1
231078	Capacitor - Run (#522858 Motor)	1
231095	Capacitor - Start (#522858 Motor)	1
284104	Condenser (Water-Cooled)	1
368325	Filter - Air (Condenser)	1
598296	Pulley - Speed Reducer (60 Hz) (Ser. #28561 Plus)	1
598540	Pulley - Drive Motor (60 Hz) (Ser. #28561 Plus)	1
763181	Valve - Water	1
162077	Blade - Fan (Air-Colled Condenser)	1

## 6.11 RIGHT-HAND SIDE

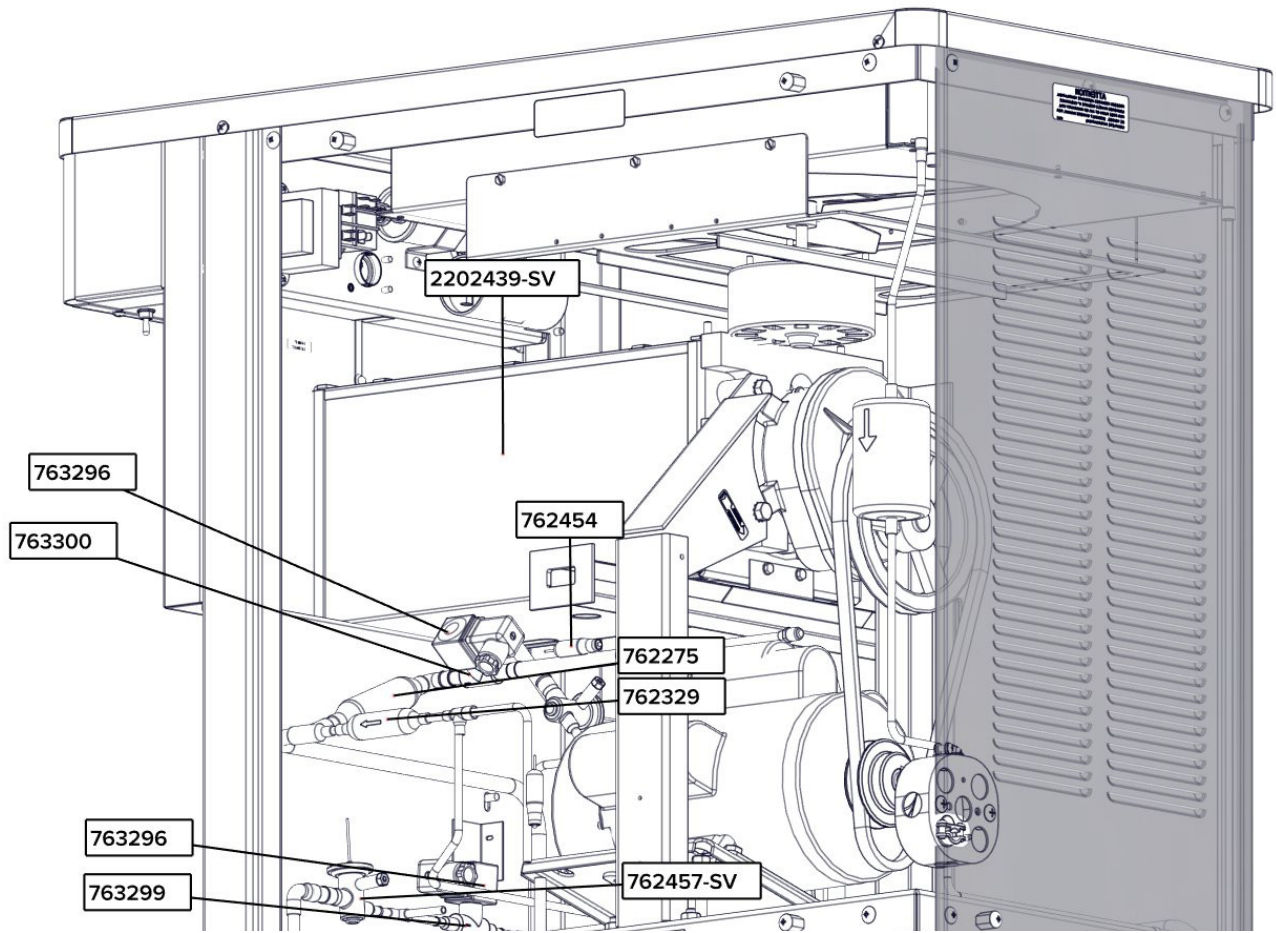

**Right-Hand Side Parts List**

Part Number	Description	Quantity
2202439-SV	Evaporator & Auger Kit	1
<a href="#">763296</a>	Valve - Solenoid Coil (Suction)	1
<a href="#">763300</a>	Valve - Solenoid (Suction)	1
763297LH	Valve - Solenoid Coil (Liquid)	1
<a href="#">763299</a>	Valve - Solenoid (Liquid)	1
<a href="#">762457-SV</a>	Valve - Expansion (w/Orifice) (Cab)	1
<a href="#">762329</a>	Valve - Magna Check (EPR) (Cab)	1
<a href="#">762275</a>	Valve - Magna Check (Cab)	1
762454	Valve - Expansion	1

## 6.12 REAR

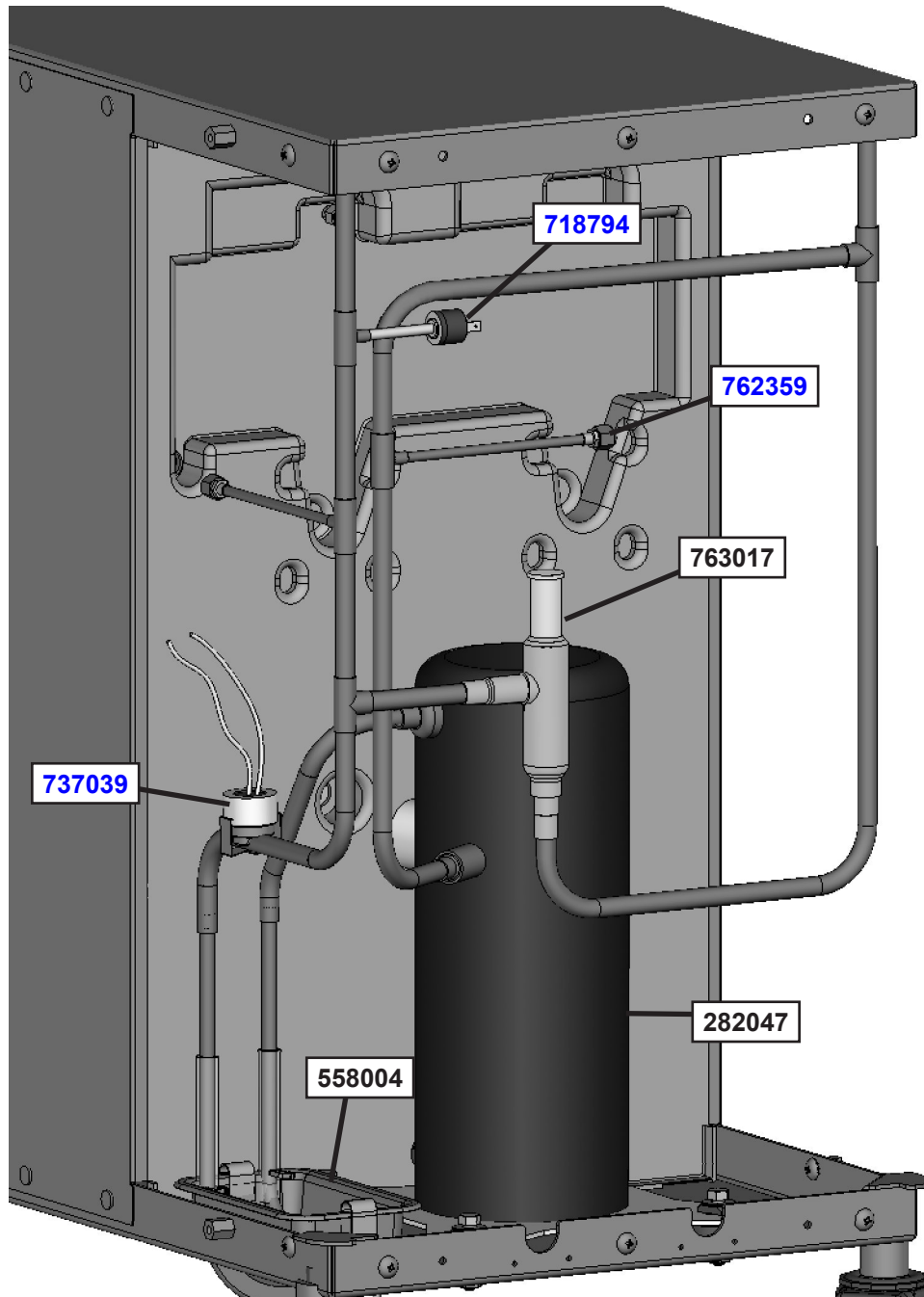

Part Number	Description	Quantity
282047	Compressor - 1 PH - 60 Hz (Scroll) (No Capacitors)	1
282059	Compressor - 1 PH - 50 Hz (Scroll) (No Capacitors)	-
558004	Condensate Pan	1
718794	Switch - High Pressure Cutout	1
737039	Thermostat - Discharge Line	1
762359	Valve Core (Schrader)	-
763017	Valve - Hot Gas Bypass	1
778027	Wrench - Allen (Cab)	1

## 6.13 BRUSHES, DECALS & LUBRICATION

Part Number	Description	Quantity
208135	Brush - 4" X 8" X 16" (Barrel)	1
208380	Brush - 1/4" X 3" X 14"	1
208387	Brush - 1/2" X 5" X 24"	1
208465	Brush - 1" X 3-1/2" X 18"	1
208467	Brush - 3/8" X 1" X 5"	1
324014	Decal - Black Arrow on White Back	1
324065	Decal - Water Inlet	1
324103	Decal - Caution Rotating Shaft	1
324106	Decal - Caution Electrical Wiring Materials	1
324107	Decal - Caution Hazardous Moving Parts	1
324125	Decal - Danger Electric Shock Hazard	1
324141	Decal - Caution Rotating Blades	1
324200	Decal - High Pressure Cut-Out	1
324208	Decal - Attention Refrigerant Leak Check	1
324346	Decal - Caution Hazardous Moving Parts	1
324478	Decal - Electrical Box	1
324509	Decal - Cleaning Instructions	1
324566	Decal - Wired According To	1
324584	Decal - Adequate Ventilation 3"	1
324686	Decal - Danger Automatic Start	1
324803	Decal - Domed Stoelting Logo (Large) (Header Panel)	1
324804	Decal - Domed Stoelting Swirl (Header Panel)	1
324825	Decal - Main Freezer Power	1
324826	Decal - Cab Off	1
324827	Decal - Freezing Cylinder	1
324835	Decal - Blender Power On / Off (SU412)	1
324837	Decal - Caution Blender (SU412)	1
508048	Lubricant - Spline (2 oz Squeeze Tube)	1
508135	Petrol Gel - 4 oz Tube	1
513625	Manual Owner's	1
1177990	Caster Kit - 4" (Set Of 4)	-

## 6.14 STAINLESS STEEL PANELS

Part Number	Description	Quantity
647653	Screw - Panel (Top, Header) & Cab (Door Handle & Bottom Hinge)	6
647899	Screw - Panel (Side, Rear & Front Shroud) & Cab (Top Hinge)	8
2183610	Panel - Top (Air-Cooled)	1
2183611	Support - Drip Tray	1
2183760	Panel - R.H. Side	1
2183761	Panel - L.H. Side	1
2183762	Panel - Rear	1
2183774	Panel - Top (Water-Cooled)	1

## 6.15 REFRIGERATION & WIRING DIAGRAMS

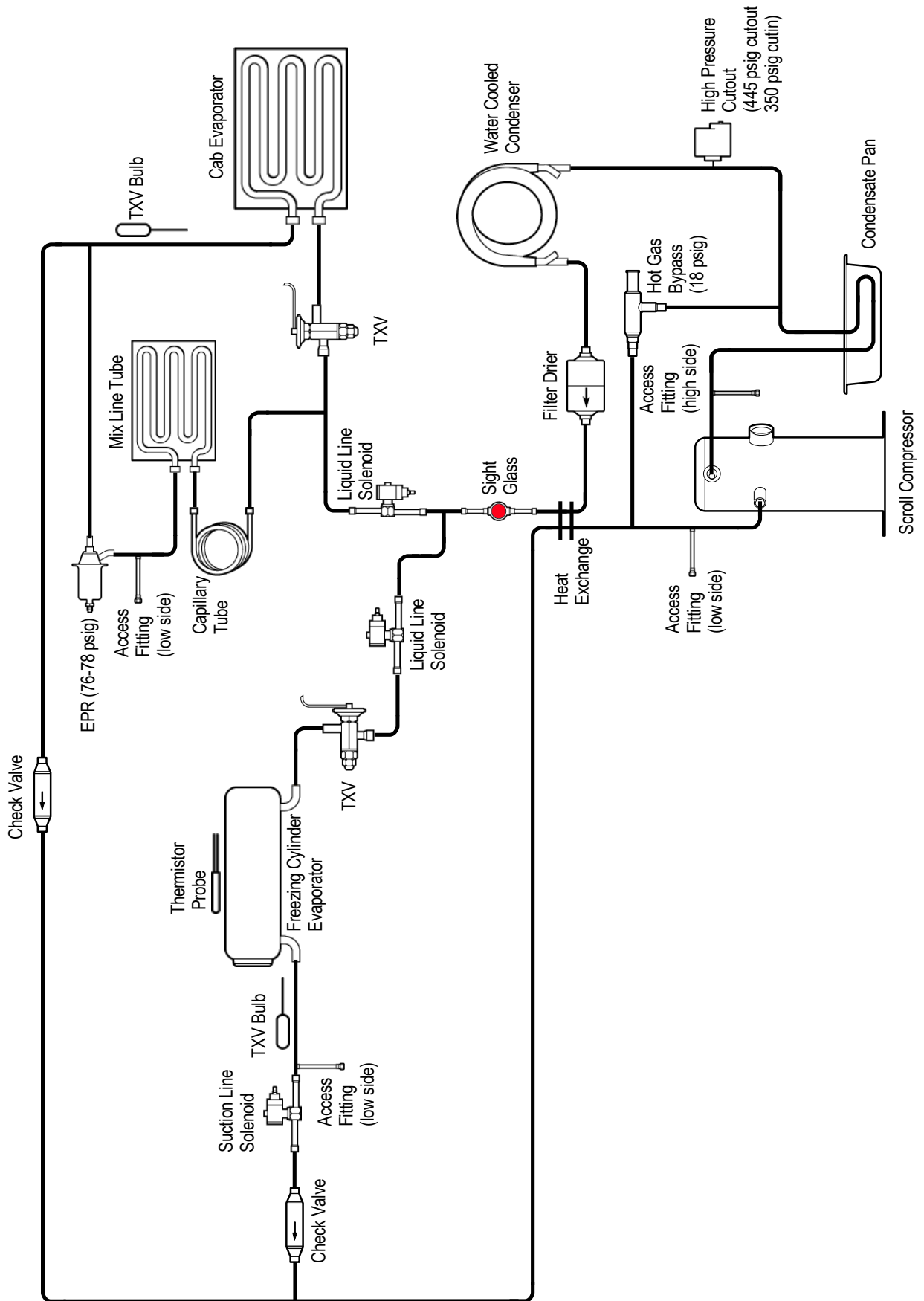

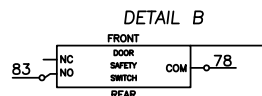
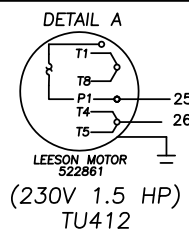
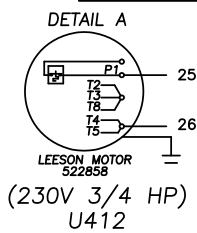
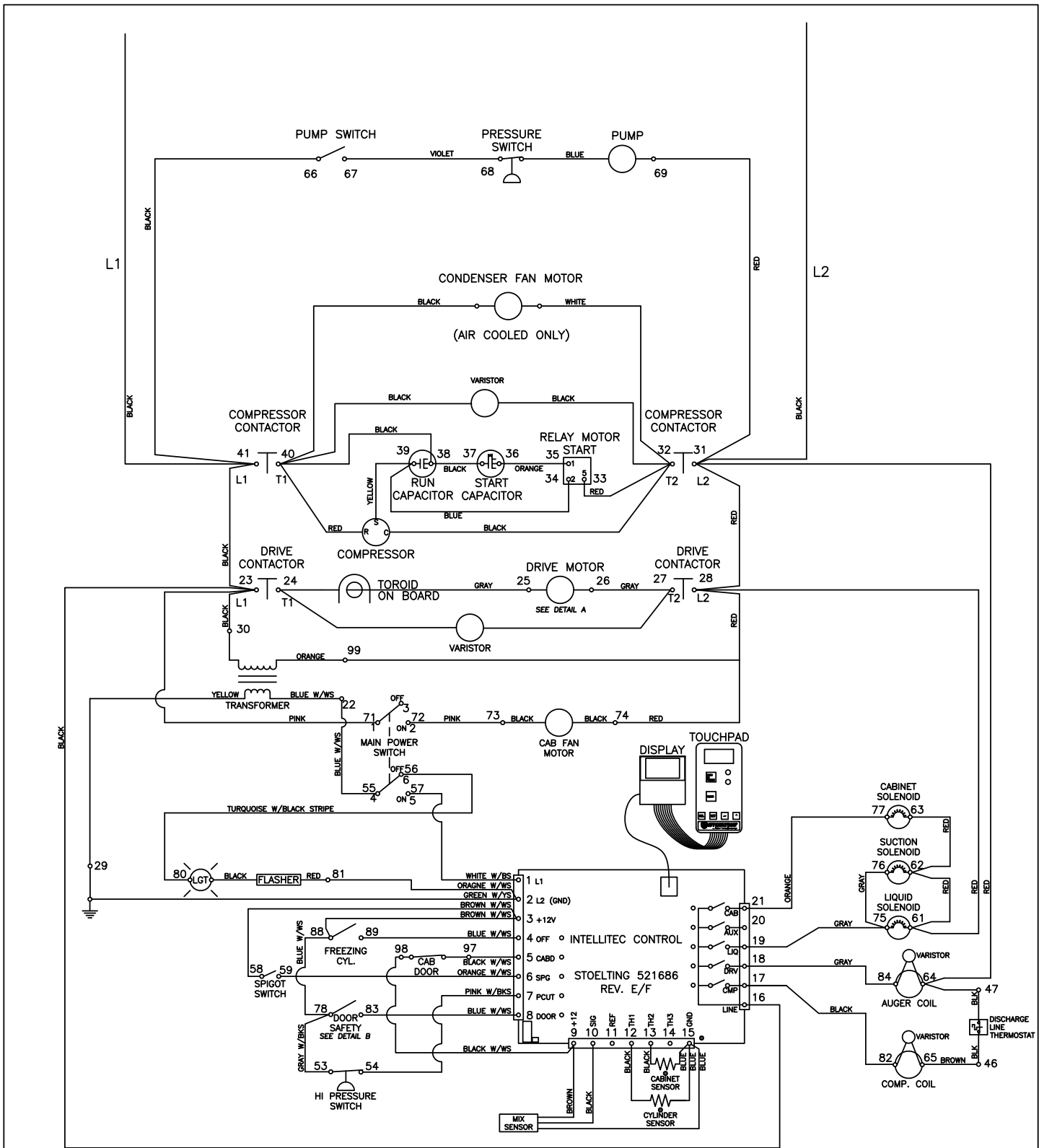

U412/TU412 INTELLITEC WIRING DIAGRAM

DRAWING NO. 2187936-WD

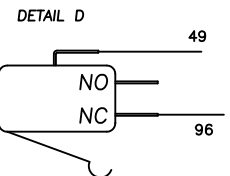
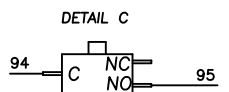
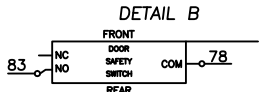
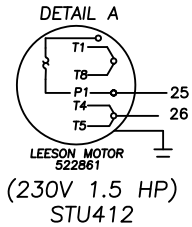
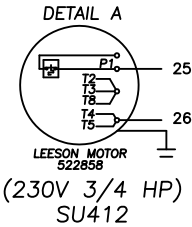
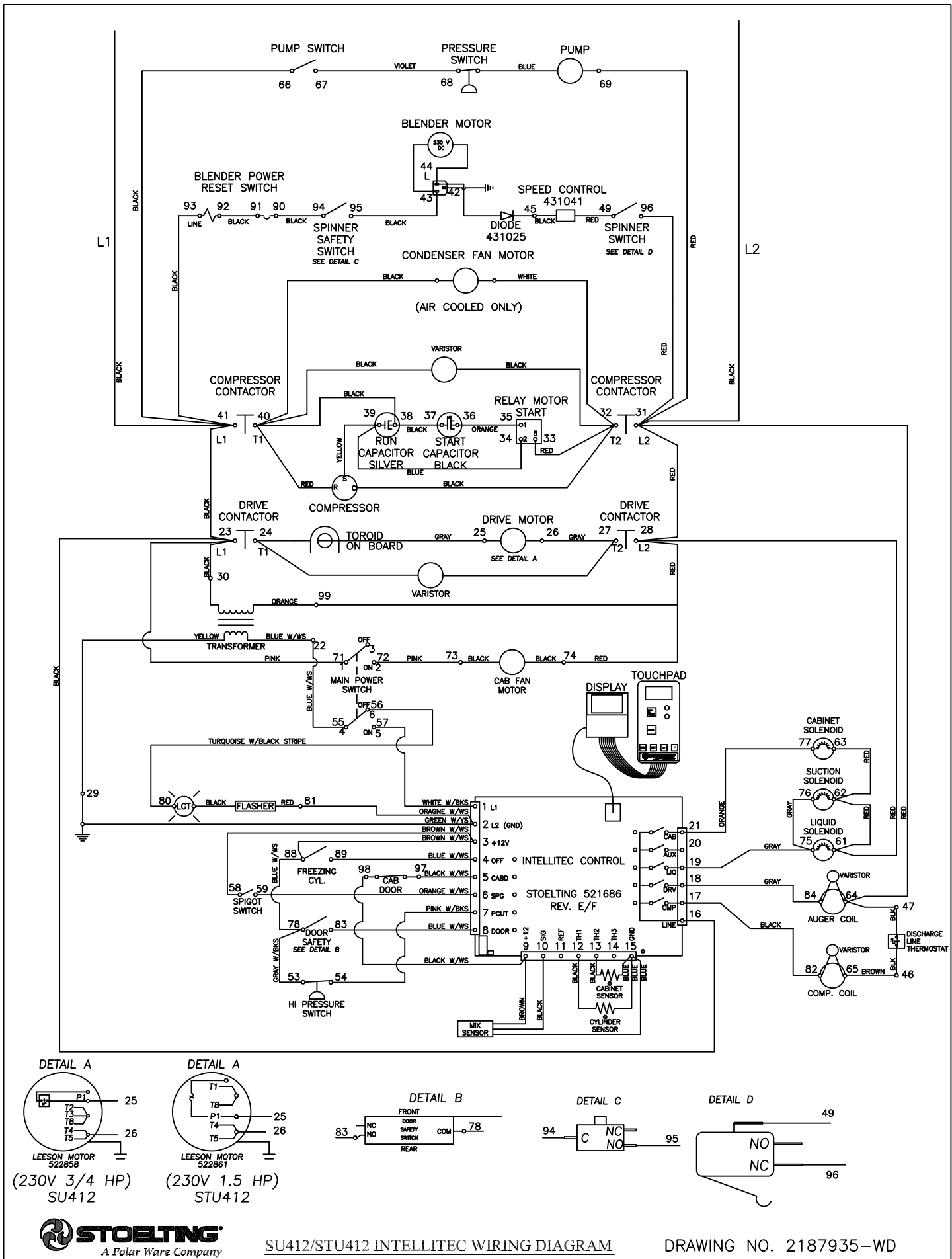

SU412/STU412 INTELLITEC WIRING DIAGRAM

DRAWING NO. 2187935-WD