



Model O431RC
OPERATORS MANUAL

Manual No. [513664](#)

Rev.2

This manual provides basic information about the machine. Instructions and suggestions are given covering its operation and care.

The illustrations and specifications are not binding in detail. We reserve the right to make changes to the machine without notice, and without incurring any obligation to modify or provide new parts for machines built prior to date of change.

DO NOT ATTEMPT to operate the machine until instructions and safety precautions in this manual are read completely and are thoroughly understood. If problems develop or questions arise in connection with installation, operation, or servicing of the machine, contact Stoelting.



stoeltingfoodservice.com

Stoelting Foodservice Equipment
502 Highway 67
Kiel, WI 53042-1600
U.S.A.

Main Tel: 800.558.5807
Fax: 920.894.7029

Customer Service: 888.429.5920
Fax: 800.545.0662
Email: foodservice@stoelting.com

© 2014 PW Stoelting, LLC

A Few Words About Safety

Safety Information

Read and understand the entire manual before operating or maintaining Stoelting equipment.

This manual provides the operator with information for the safe operation and maintenance of Stoelting equipment. As with any machine, there are hazards associated with their operation. For this reason safety is emphasized throughout the manual. To highlight specific safety information, the following safety definitions are provided to assist the reader.

The purpose of safety symbols is to attract your attention to possible dangers. The safety symbols, and their explanations, deserve your careful attention and understanding. The safety warnings do not by themselves eliminate any danger. The instructions or warnings they give are not substitutes for proper accident prevention measures.

If you need to replace a part, use genuine Stoelting parts with the correct part number or an equivalent part. We strongly recommend that you do not use replacement parts of inferior quality.



Safety Alert Symbol:

This symbol Indicates danger, warning or caution. Attention is required in order to avoid serious personal injury. The message that follows the symbol contains important information about safety.

Signal Word:

Signal words are distinctive words used throughout this manual that alert the reader to the existence and relative degree of a hazard.



The signal word "WARNING" indicates a potentially hazardous situation, which, if not avoided, may result in death or serious injury and equipment/property damage.



The signal word "CAUTION" indicates a potentially hazardous situation, which, if not avoided, may result in minor or moderate injury and equipment/property damage.

CAUTION

The signal word "CAUTION" not preceded by the safety alert symbol indicates a potentially hazardous situation, which, if not avoided, may result in equipment/property damage.

NOTE (or NOTICE)

The signal word "NOTICE" indicates information or procedures that relate directly or indirectly to the safety of personnel or equipment/property.

TABLE OF CONTENTS

Section	Description	Page
1	Description and Specifications	
1.1	Description	1
1.2	Specifications	2
2	Installation Instructions	
2.1	Safety Precautions	3
2.2	Shipment and Transit	3
2.3	Freezer Installation	3
2.4	Installing Permanent Wiring	3
2.5	Mix Pump	4
A.	Mix Pump Hose Installation	4
B.	Mix Pickup Hose Installation	4
C.	Mix Low Level Indicator Adjustment	6
3	Initial Set-Up and Operation	
3.1	Operator's Safety Precautions	7
3.2	Operating Controls and Indicators	7
3.3	Important Information Regarding Cleaning and Sanitizing	9
3.4	Disassembly of Freezer Parts	10
A.	Disassembly of Front Door	10
B.	Disassembly of Auger	11
3.5	Cleaning Disassembled Parts	11
3.6	Sanitizing Freezer Parts	11
3.7	Cleaning the Freezer	11
3.8	Assembling Freezer	11
3.9	Sanitizing	12
3.10	Initial Freeze Down and Operation	13
A.	Adding Mix	13
B.	Preparing the IntelliTec Control	13
C.	Initial Freeze Down	13
D.	Adjusting the IntelliTec Control	14
E.	Serving Product	14
3.11	Normal Freeze Down and Operation	14
3.12	Mix Information	15
3.13	Operation of Mix Pump	15
3.14	Mix Pump Cleaning	16
3.15	Disassembly and Inspection of Removable Parts	16

Section	Description	Page
4	Maintenance and Adjustments	
4.1	Freezer Adjustment	17
4.2	Product Consistency Adjustment	17
4.3	Locking the Control Panel	17
4.4	Obtaining Readings and Modifying Settings (Service Personnel Only)	17
4.5	Readings (Service Personnel Only)	18
4.6	Adjustments (Service Personnel Only)	19
4.7	Other Settings (Service Personnel Only)	19
4.8	Overrun Adjustment	19
4.9	Mix Pump Hose Reposition	20
4.10	Mix Pump Hose Replacement	20
4.11	Cab Temperature Adjustment	21
4.12	Drive Belt Tension Adjustment	21
4.13	Condenser Cleaning (Air-Cooled Freezers)	22
4.14	Preventative Maintenance	22
4.15	Extended Storage	22
5	Troubleshooting	
5.1	Error Codes	23
5.2	Troubleshooting - Error Codes	23
5.3	Troubleshooting - Freezer	25
5.4	Troubleshooting - Mix Pump	26
6	Replacement Parts	
6.1	Brushes, Decals and Lubrication	29
6.2	Spigot Extension	29
6.3	Auger Shaft and Faceplate Parts	30
6.4	Cab Tubing Assembly	31

SECTION 1 DESCRIPTION AND SPECIFICATIONS

1.1 DESCRIPTION

The Stoelting O431RC floor model machine is pressure fed. The machine is equipped with fully automatic controls to provide a uniform product. The machine is designed to operate with almost any type of commercial soft-serve or non-dairy mix available, including ice milk, ice cream, yogurt, and frozen dietary desserts. The O431RC has a rear opening refrigerated cabinet with rear controls.

This manual is designed to assist qualified service personnel and operators in the installation, operation and maintenance of the Stoelting O431RC pressure machine.



Figure 1-1 Model O431RC Freezer

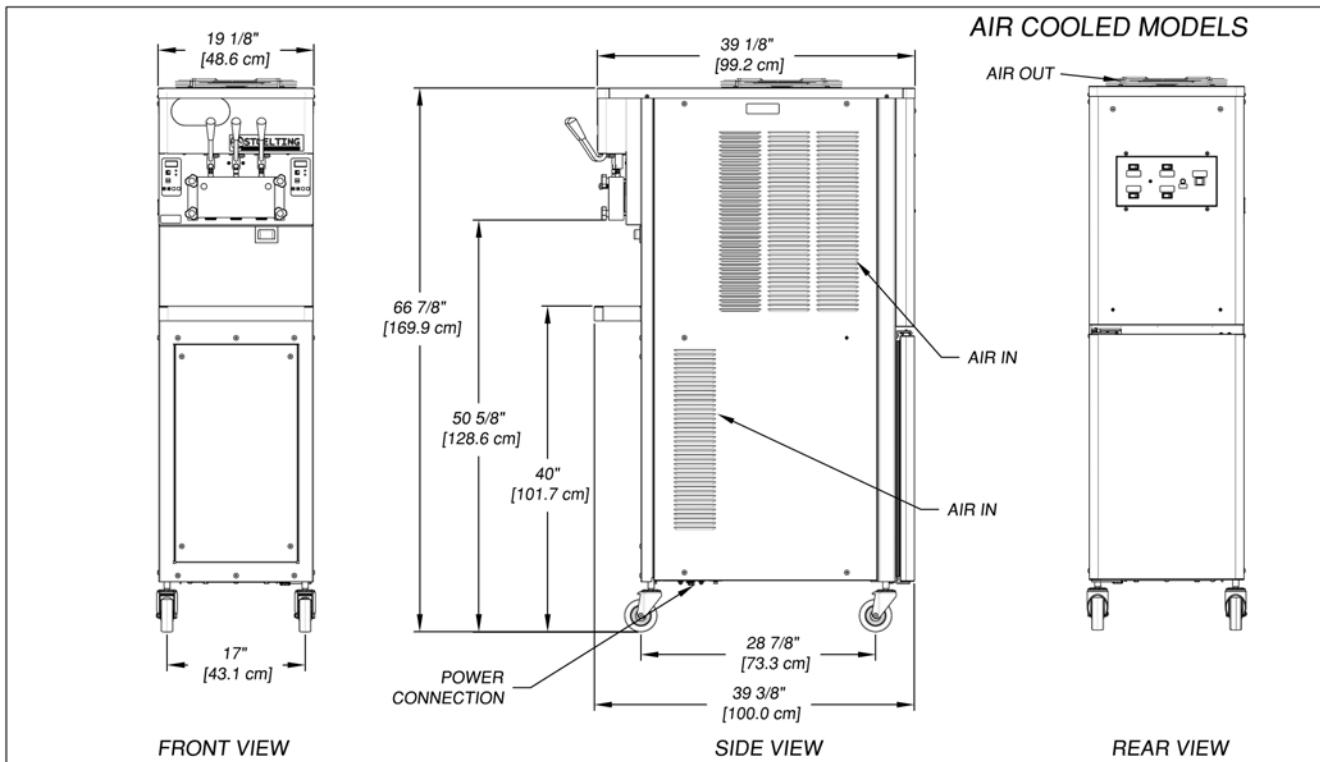

1.2 SPECIFICATIONS

Model O431 RC													
Dimensions	<table style="width: 100%; border-collapse: collapse;"> <thead> <tr> <th style="width: 30%;"></th> <th style="width: 35%; text-align: center;">Machine</th> <th style="width: 35%; text-align: center;">with crate</th> </tr> </thead> <tbody> <tr> <td style="padding-left: 20px;">width</td> <td style="text-align: center;">19-1/8" (48,6 cm)</td> <td style="text-align: center;">27" (68,6 cm)</td> </tr> <tr> <td style="padding-left: 20px;">height</td> <td style="text-align: center;">67-7/8" (172,4 cm)</td> <td style="text-align: center;">78" (198,1 cm)</td> </tr> <tr> <td style="padding-left: 20px;">depth</td> <td style="text-align: center;">37-3/4" (95,9 cm)</td> <td style="text-align: center;">48" (121,9 cm)</td> </tr> </tbody> </table>		Machine	with crate	width	19-1/8" (48,6 cm)	27" (68,6 cm)	height	67-7/8" (172,4 cm)	78" (198,1 cm)	depth	37-3/4" (95,9 cm)	48" (121,9 cm)
	Machine	with crate											
width	19-1/8" (48,6 cm)	27" (68,6 cm)											
height	67-7/8" (172,4 cm)	78" (198,1 cm)											
depth	37-3/4" (95,9 cm)	48" (121,9 cm)											
Weight	<table style="width: 100%; border-collapse: collapse;"> <tbody> <tr> <td style="width: 30%;"></td> <td style="width: 35%; text-align: center;">500 lbs (226,7 kg)</td> <td style="width: 35%; text-align: center;">650 lbs (294,8 kg)</td> </tr> </tbody> </table>		500 lbs (226,7 kg)	650 lbs (294,8 kg)									
	500 lbs (226,7 kg)	650 lbs (294,8 kg)											
Electrical	1 Phase, 208-240 VAC, 60Hz												
running amps	<table style="width: 100%; border-collapse: collapse;"> <thead> <tr> <th style="width: 50%; text-align: center;">Air Cooled</th> <th style="width: 50%; text-align: center;">Water Cooled</th> </tr> </thead> <tbody> <tr> <td style="text-align: center;">approximately 17A</td> <td style="text-align: center;">approximately 15A</td> </tr> <tr> <td style="text-align: center;">NEMA L6-30P</td> <td style="text-align: center;">NEMA L6-30P</td> </tr> </tbody> </table>	Air Cooled	Water Cooled	approximately 17A	approximately 15A	NEMA L6-30P	NEMA L6-30P						
Air Cooled	Water Cooled												
approximately 17A	approximately 15A												
NEMA L6-30P	NEMA L6-30P												
connection type	<table style="width: 100%; border-collapse: collapse;"> <tbody> <tr> <td style="width: 50%; text-align: center;">NEMA L6-30P</td> <td style="width: 50%; text-align: center;">NEMA L6-30P</td> </tr> </tbody> </table>	NEMA L6-30P	NEMA L6-30P										
NEMA L6-30P	NEMA L6-30P												
International Option	1 Phase, 220-240 VAC, 50Hz or 3 Phase, 380-415 VAC, 50Hz												
Compressor	15,000 Btu/hr Scroll™ Compressor												
Drive Motor	Two - 3/4 hp												
Air Flow	Air cooled units require 3" (7,6 cm) air space on both sides.												
Plumbing Fittings	Water cooled units require 1/2" N.P.T. water and drain fittings.												
Hopper Volume	Two - 5.5 gallons (20,82 liters)												
Freezing Cylinder Volume	Two - 1 gallon (3,79 liters)												

SECTION 2 INSTALLATION INSTRUCTIONS

2.1 SAFETY PRECAUTIONS

Do not attempt to operate the machine until the safety precautions and operating instructions in this manual are read completely and are thoroughly understood.

Take notice of all warning labels on the machine. The labels have been put there to help maintain a safe working environment. The labels have been designed to withstand washing and cleaning. All labels must remain legible for the life of the machine. Labels should be checked periodically to be sure they can be recognized as warning labels.

If danger, warning or caution labels are needed, indicate the part number, type of label, location of label, and quantity required along with your address and mail to:

STOELTING, INC.
ATTENTION: Customer Service
502 Hwy. 67
Kiel, Wisconsin 53042

2.2 SHIPMENT AND TRANSIT

The machine has been assembled, operated and inspected at the factory. Upon arrival at the final destination, the entire machine must be checked for any damage which may have occurred during transit.

With the method of packaging used, the machine should arrive in excellent condition. THE CARRIER IS RESPONSIBLE FOR ALL DAMAGE IN TRANSIT, WHETHER VISIBLE OR CONCEALED. Do not pay the freight bill until the machine has been checked for damage. Have the carrier note any visible damage on the freight bill. If concealed damage and/or shortage is found later, advise the carrier within 10 days and request inspection. The customer must place a claim for damages and/or shortages in shipment with the carrier. Stoelting, Inc. cannot make any claims against the carrier.

2.3 MACHINE INSTALLATION



WARNING

Installation must be completed by a qualified electrician/refrigeration specialist.

Incorrect installation may cause personal injury, severe damage to the machine and will void factory warranty.

Installation of the machine involves moving the machine close to its permanent location, removing all crating, setting in place, assembling parts, and cleaning.

- A. Uncrate the machine.

- B. Install the four casters. Turn the threaded end into the machine until no threads are showing. To level, turn out casters no more than 1/4" maximum, then tighten all jam nuts.
- C. The machine must be placed in a solid level position.

NOTE

Accurate leveling is necessary for correct drainage of freezing cylinder and to insure correct overrun.

- D. Machines with air-cooled condensers require 3" (7,6 cm) air space on both sides and back for proper circulation. (Fig. 2-1)
- E. Machines that have a water-cooled condenser require 1/2" NPT supply and drain fittings.
- F. In air-cooled machines, use a voltmeter to measure incoming voltage. If the supply voltage is 215 or less, then the buck-boost transformer must be connected to the fan motor. Refer to the wiring diagram located behind the header panel to connect.

NOTE

Supply voltage must be checked to make sure the fan motor operates properly.



Figure 2-1 Space and Ventilation Requirements

2.4 INSTALLING PERMANENT WIRING

If permanent wiring is required by local codes, the following procedure must be performed:

- A. Refer to the nameplate on the side panel of the machine for specific electrical requirements. Make sure the power source in the building matches the nameplate requirements.
- B. Remove the back panel and the junction box cover located at the bottom of the machine.
- C. Install permanent wiring according to local code.

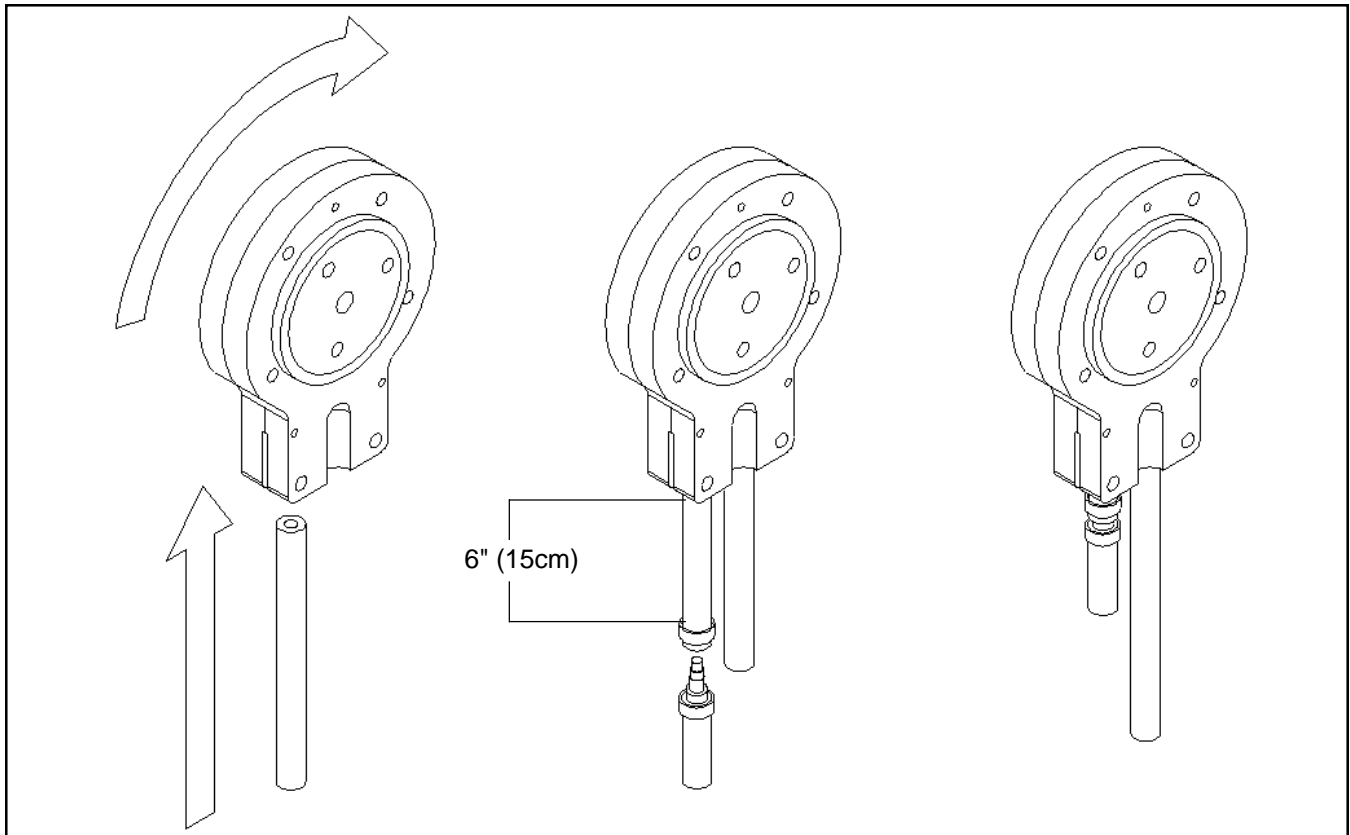

Figure 2-2 Mix Hose Installation

2.5 MIX PUMP

A. MIX PUMP HOSE INSTALLATION

Follow the steps below to install the mix pump hose in the cabinet part of the machine.

1. Turn the mix pump on. The switch is located at the top of the cabinet.
2. Feed one end of the mix pump hose into the entering or pickup hose side (left) of black cover (Fig 2-2).

NOTE

Feed the tube into the clamp so the natural curve of the tube is towards the outside of the black cover. This prevents the hose from looping around the black cover twice.

3. Gently push the hose into the black cover until it begins to feed.
4. Allow the hose to feed itself through the pump until about 6" (15cm) remains on the entering side.
5. Turn the pump off.
6. Connect the mix pump hose to the elbow fitting (located on the left side of the mix line manifold) using a small hose clamp. Be careful not to twist the mix hose.
7. Turn the pump on.

8. Allow the remaining 6" (15cm) of tubing to feed through pump until the hose adapter prevents further feeding.
9. Turn the pump off.

CAUTION

Risk of Product Damage

Air/Mix Tee must remain below the black cover clamp. If the Tee is above the pump, mix may drain into the air compressor resulting in pump damage.

10. Connect the free end of the mix pump hose to the 3-way Tee (Fig. 2-3). When all connections are complete, the 3-way Tee must be lower than the black pump housing.

B. MIX PICKUP HOSE INSTALLATION

The O431 machine may be connected to the standard mix container or up to three prepacked mix bags. Follow the instructions below that match your configuration.

Standard Connection:

1. Connect a 2" (5cm) length of 3/8" (9,5mm) ID plastic food grade tubing to the mix pickup assembly. Secure with hose clamps. Place the assembly through the hole in the cover and install the retaining clip.

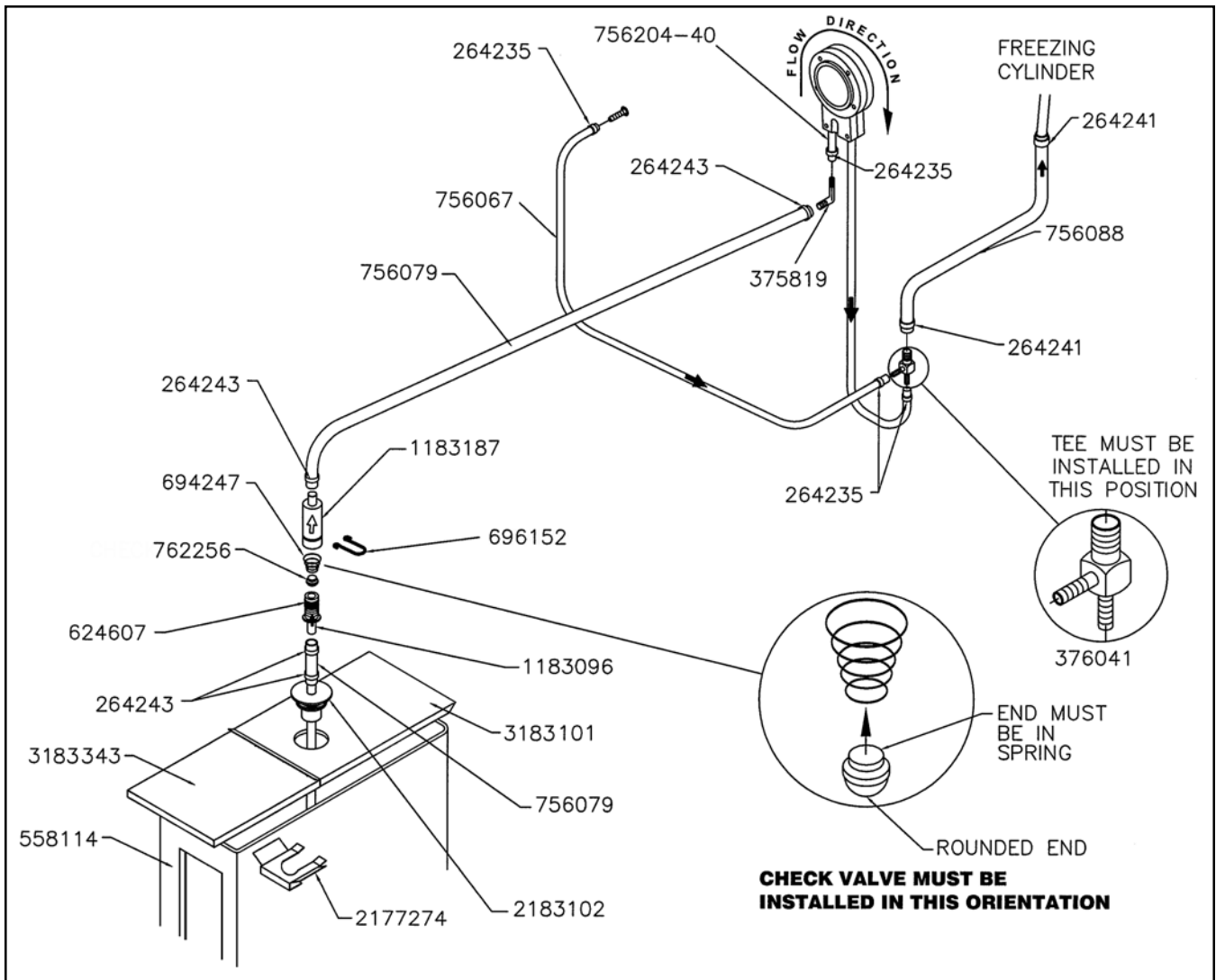

Figure 2-3 Mix Pump Connections for Standard Mix Container

2. Connect the free end of the tubing to the mix check valve. Observe the direction of the check valve flow arrow. Secure with a hose clamp. Connect a 24" (61cm) length of 3/8" (9,5mm) ID plastic food grade tubing to the free end of the check valve and secure with a hose clamp.
3. Connect the elbow fitting to the free end of the tubing. Connect the opposite end of the elbow to 1/4" ID tan tubing on the left side of the pump head. Secure with hose clamps (Fig. 2-3).
2. Slide the hose clip over free end of 3/8" (9,5mm) ID plastic food grade tubing. Attach the free end of the tubing to a manifold adapter. Secure with a large hose clamp or equivalent.
3. Push the manifold adapter with spring and valve into the left port (nearest the manifold outlet) of the mix inlet manifold and secure with a retaining clip. (Fig. 2-5).

When Using Bag Connection System (BCS) with Three Bags (optional kit #2183987):

The position of the three bags in the mix container is important. The bag that is connected nearest the outlet of the manifold will drain last and should be placed at the back of the mix container. The mix low level indicator relies on proper bag placement.

1. Connect 3/8" (9,5mm) ID plastic food grade tubing to a bag adapter. Secure with hose clamps.

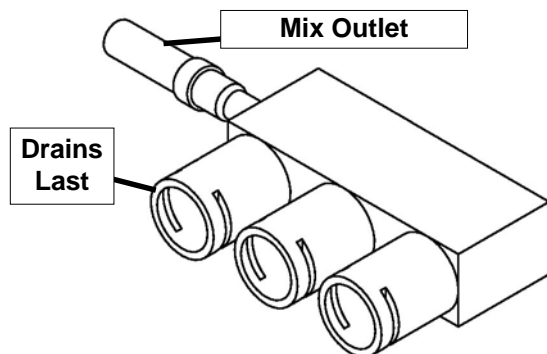

Figure 2-4 BCS Mix Inlet Manifold

4. Repeat steps 1 to 3 for the middle port and for the right port of the mix inlet manifold.
5. Place three mix bags into the mix container.
6. Connect the bag adapter attached to the left side of the manifold (closest to the mix outlet) to the mix bag in the back of the mix container.
7. Connect the bag adapter attached to the middle of the manifold to the mix bag in the middle of the mix container.
8. Connect the bag adapter attached to the right side of the manifold (farthest from the mix outlet) to the mix bag in the front of the mix container.

When Using Bag Connection System (BCS) with One or Two Bags (optional kit #2183987):

When connecting one or two bags, the manifold adapters must be installed closest to the manifold outlet and the manifold plug(s) must be placed farthest from the manifold outlet.

1. Connect 3/8" (9,5mm) ID plastic food grade tubing to a bag adapter. Secure with hose clamps.
2. Slide the hose clip over the free end of the tubing. Attach the free end of the tubing to a manifold adapter. Secure with a large hose clamp.
3. Push the manifold adapter with spring and valve into the left port (nearest the manifold outlet) of the mix inlet manifold and secure with retaining clip. (See Figure 2-5).
4. If using two mix bags, repeat steps 1 to 3 for the middle port.
5. Install a manifold plug into each empty inlet and secure with a retaining clip.
6. Place the mix bag(s) into the mix container.
7. Connect the bag adapter attached to the left side of the manifold (closest to the mix outlet) to the mix bag in the back of the mix container.

C. MIX LOW LEVEL INDICATOR ADJUSTMENT

The sensitivity of the "Mix Low" indication that displays on the control panel can be adjusted to operator preference. If more advanced notice of low mix is required, loosen the black adjustment knobs located on the sensor brackets at the back of the machine cabinet and slide the bracket upwards. If the "Mix Low" message appears while there is still sufficient mix in the container, slide the bracket downward. Be sure to tighten the adjustment knobs after properly positioning the sensor.

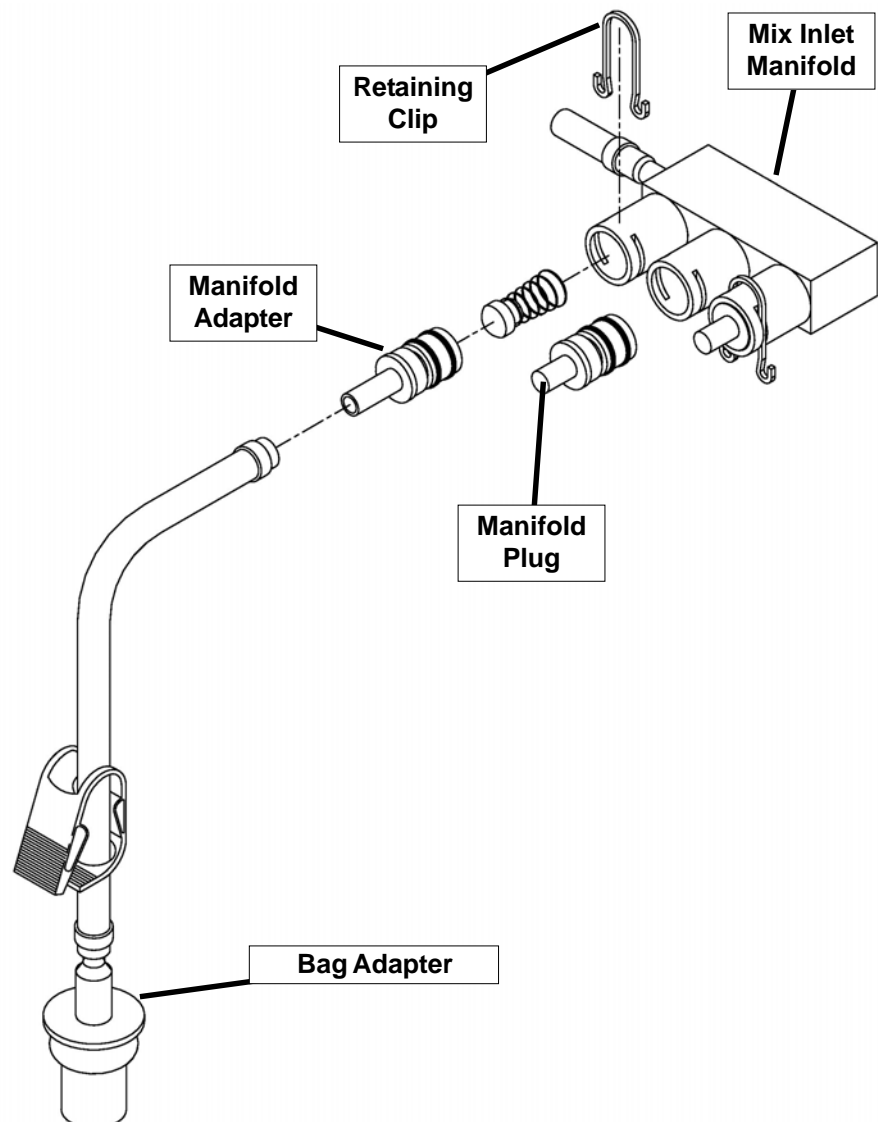

Figure 2-5 Bag Connection System (Optional)

SECTION 3 INITIAL SET-UP AND OPERATION

3.1 OPERATOR'S SAFETY PRECAUTIONS

SAFE OPERATION IS NO ACCIDENT; observe these rules:

- A. Know the machine. Read and understand the Operating Instructions.
- B. Notice all warning labels on the machine.
- C. Wear proper clothing. Avoid loose fitting garments, and remove watches, rings or jewelry that could cause a serious accident.
- D. Maintain a clean work area. Avoid accidents by cleaning up the area and keeping it clean.
- E. Stay alert at all times. Know which switch, push button or control you are about to use and what effect it is going to have.
- F. Disconnect power for maintenance. Never attempt to repair or perform maintenance on the machine until the main electrical power has been disconnected.
- G. Do not operate under unsafe operating conditions. Never operate the machine if unusual or excessive noise or vibration occurs.

3.2 OPERATING CONTROLS AND INDICATORS

Before operating the machine, it is required that the operator know the function of each operating control. Refer to Figure 3-1 for the location of the operating controls on the machine. For the information regarding error codes displayed on the control panel, refer to the troubleshooting section of this manual.

A. MAIN FREEZER POWER SWITCH

The Main Freezer Power switch is a two position rocker switch that supplies power to the IntelliTec control, freezing cylinder circuits and lower cabinet refrigeration system. When the switch is placed in the ON position, the cabinet refrigeration system will run until the preset temperature is reached; then it will cycle ON and OFF to maintain that temperature. Power to the freezing cylinders can then be controlled with the Freezing Cylinder OFF/ON switch.

B. FREEZING CYLINDER OFF/ON SWITCH

The Freezing Cylinder OFF/ON switch is a two position toggle switch used to supply power to each freezing cylinder control circuit. When the switch is in the OFF position, the freezing cylinder's refrigeration system and auger will not operate. When the switch is in the ON position, the machine will be operational.

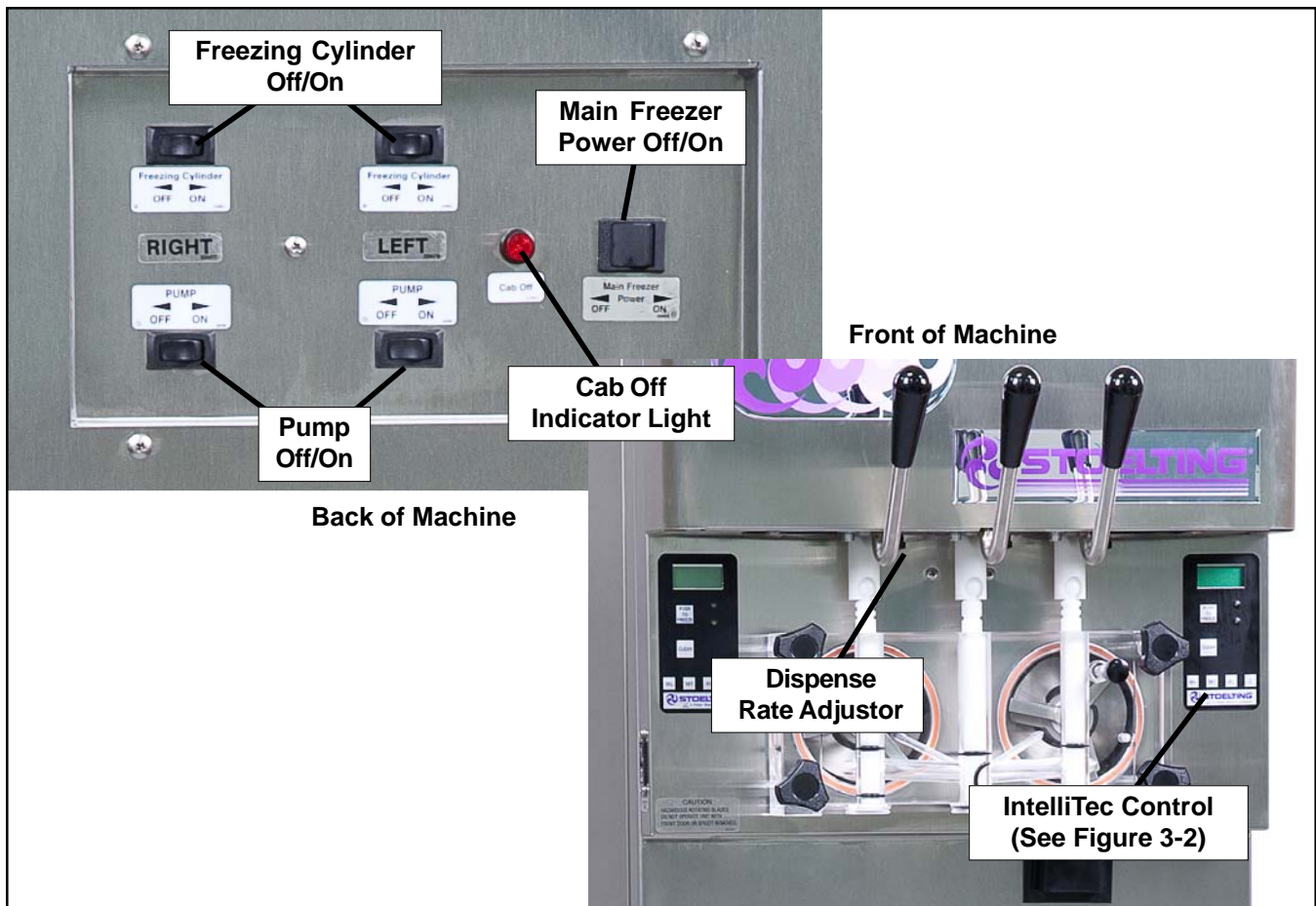

Figure 3-1 Machine Controls

C. SPIGOT SWITCH

The spigot switch is mounted to the spigot cam assembly behind the header panel. When the spigot is opened to dispense product, the spigot switch opens and the "Serve Mode" begins.

D. DISPENSE RATE ADJUSTOR

The dispense rate adjustor is located under the header panel, to the immediate right of each spigot handle. Turning the knob counterclockwise will decrease the dispense rate.

E. CAB OFF INDICATOR LIGHT

A flashing light indicates the Main Freezer Power Switch is in the OFF position; no refrigeration is being supplied to the cab. Place the Main Freezer Power switch in the ON position for cab refrigeration.

F. PUMP SWITCH

The pump motor switch is the toggle switch located at the back of the machine. When the switch is placed in the OFF position, the pump will not run. When the switch is placed in the ON position, the pump will run until the preset pressure is reached. It then cycles on and off as product is drawn to maintain that pressure.

G. PUSH TO FREEZE BUTTON

The PUSH TO FREEZE button is a snap switch used to initiate "Serve Mode".

NOTE

After the PUSH TO FREEZE button is pressed, the drive motor starts. After a 3-second delay, the compressor will start.

H. LEDS

The membrane switch (touchpad) features two lights: a green LED and an amber LED. The green LED is lit during "Serve Mode". During freeze down, it is not lit. When product consistency approaches 75% in the freezing cylinder, the green LED flashes. The amber LED is on during all other modes. Both LEDs alternatively flash if an error occurs or if the freezing cylinder is off.

I. CLEAN BUTTON

The CLEAN button is a snap switch. When the button is pressed, the freezing cycle stops and the drive motor will start. A CLEAN message will display on the LCD screen along with a 5-minute countdown timer. To exit the CLEAN mode, turn the Freezing Cylinder OFF/ON switch to the OFF position or press the CLEAN button again. If the machine is left in CLEAN for more than 20 minutes, an error code (E4) will be displayed on the display panel. Place the Freezing Cylinder OFF/ON switch in the OFF position and back in the ON position to clear this error.

J. DRIVE MOTOR OVERLOAD

The internal drive motor overload will trip if the drive motor is overloaded. It will reset after approximately 10-12 minutes. If the drive motor continues to trip, refer to Troubleshooting in Section 5.

K. MIX LOW LIGHT INDICATOR

A MIX LOW message will appear on the LCD display to alert the operator of a low mix condition. The message will display when there is approximately one gallon of mix left in the mix container or when one bag of the Bag Connection System (BCS) is empty. When the MIX LOW message is displayed, refill the container or replace a bag immediately.

L. MENU NAVIGATION BUTTONS

The Menu Navigation Buttons allow the user to display information regarding the machine's status of operation as well as adjust product consistency (Fig. 3-2).

Selection Button (SEL) The SEL button is used in combination with the up arrow button to enter into the settings of the IntelliTec control. This button is also used to navigate through the control settings menu.

Set Button (SET) The SET button is used to save a change made to the product consistency setting. It is also used to save changes when modifying control settings.

Left Arrow Button (←) If the left arrow button is pressed for 5 seconds, the display will remain lit. To turn the light off, press the left arrow button for 5 seconds. The left arrow button is used primarily to navigate through the control settings.

Up Arrow Button (↑) After pressing the SET button, the up arrow button will change the value of the product consistency setting. This button is used primarily to navigate through the control settings.



Figure 3-2 IntelliTec Control

3.3 IMPORTANT INFORMATION REGARDING CLEANING AND SANITIZING

Soft serve and shake machines require special consideration when it comes to food safety and proper cleaning and sanitizing.

The following information specifically covers issues for cleaning and sanitizing frozen dessert machines. This information is meant to supplement a comprehensive food safety program.

SOIL MATERIALS ASSOCIATED WITH FROZEN DESSERT MACHINES

MILKFAT/BUTTERFAT – As components of ice-cream/frozen custard mix, these soils will accumulate on the interior surfaces of the machine and its parts. Fats are difficult to remove and help attribute to milkstone buildup.

MILKSTONE – Is a white/gray film that forms on equipment and utensils that are exposed to dairy products. These films will accumulate slowly on surfaces because of ineffective cleaning, use of hard water, or both. Milkstone is usually a porous deposit, which will harbor microbial contaminants and eventually defy sanitizing efforts.

Once milkstone has formed, it is very difficult to remove. Without using the correct product and procedure, it is nearly impossible to remove a thick layer of milkstone.

(NOTE: general-purpose cleaners DO NOT remove milkstone.) This can lead to high bacteria counts and a food safety dilemma.

IT IS BEST TO CONTROL MILKSTONE ON A DAILY BASIS BEFORE IT CAN BECOME A SIGNIFICANT FOOD SAFETY PROBLEM.

In addition to food safety, milkstone can cause premature wear to machine parts, which can add to costs for replacement parts or possibly more expensive repairs if worn machine parts are not replaced once they have become excessively worn.

IMPORTANT DIFFERENCES BETWEEN CLEANING AND SANITIZING

CLEANING vs. SANITIZING

It is important to distinguish between cleaning and sanitizing. Although these terms may sound synonymous, they are not. BOTH are required for adequate food safety and proper machine maintenance.

CLEANING

- Is the removal of soil materials from a surface.
- Is a prerequisite for effective sanitizing.

NOTE

An UNCLEAN surface will harbor bacteria that can defy sanitizing efforts.

Bacteria can develop and resist sanitizing efforts within a layer of soil material (milkstone). Thorough cleaning procedures that involve milkstone removal are critical for operators of frozen dessert machines.

SANITIZING

- Kills bacteria.
- Can be effective on clean surfaces only.

NOTE

Using a SANITIZER on an unclean surface will not guarantee a clean and safe frozen dessert machine.

PROPER DAILY MAINTENANCE:

The Only Way to Assure Food Safety and Product Quality

Proper daily maintenance can involve a wide variety of products and procedures. Overall, the products and procedures fall into three separate categories. (Please note that this is a brief overview intended for informational purposes only.)

1. **CLEANING** – This involves draining mix from the freezing cylinder and rinsing the machine with water. Next, a cleaner is run through the machine. Then, the machine is disassembled and removable parts are taken to the sink for cleaning.
2. **MILKSTONE REMOVAL** – Since most cleaners do not have the ability to remove milkstone, the use of a delimer becomes necessary. Although this procedure may not be needed on a daily basis, it will usually follow the cleaning procedure. It requires letting a delimer solution soak in the machine for an extended period. Individual parts are also soaked in a deliming solution for an extended period of time (more about delimers in Additional Information).
3. **SANITIZING** – After the machine has been cleaned and contains no milkstone, the machine is reassembled. Then a FDA-approved sanitizing solution is run through the machine to kill bacteria. The machine is then ready for food preparation.

As a recommended cleaner and sanitizer for your frozen dessert machine, STERA-SHEEN has proven to be one of the best daily maintenance products for:

- **CLEANING** – Thorough removal of all solids including butterfat and milk fat.
- **MILKSTONE REMOVAL** – Complete removal of milkstone.
- **SANITIZING** – FDA-approved no rinse sanitizer for food contact surfaces.

ADDITIONAL INFORMATION

THE USE OF DELIMERS

A delimer is a strong acid that has the ability to dissolve milkstone. This type of chemical may become necessary once high levels of milkstone have developed. While these products are very effective for removing HIGH levels of milkstone, they are not ideal for two reasons:

1. **PRODUCT SAFETY** – Strong acids are dangerous chemicals. Carefully follow safety instructions provided with delimer products.

2. **MACHINE DAMAGE** – Strong acids will attack metal and rubber causing premature wear of parts. The use of a delimer needs to be closely monitored to avoid damage to machine surfaces and parts.

With proper daily use of STERA-SHEEN or its equivalent, there is no need for the use of a DELIMER.

DO NOT USE BLEACH

- BLEACH HAS ABSOLUTELY NO CLEANING PROPERTIES.
- BLEACH IS CORROSIVE. It will damage components of the machine causing premature wear and metal corrosion.

GENERAL PURPOSE CLEANERS

General purpose cleaners do not have the ability to remove milkstone. Milkstone will become a problem if not remedied with additional products and procedures.

THE USE OF CHLORINE TEST STRIPS

“Test strips” are used to determine concentrations of active chlorine in sanitizing solutions. To use the strips, tear off a small portion and submerge it into the sanitizing solution. Then, compare the color change to the color key on the side of the test strip dispenser to determine the approximate chlorine concentration.

The ideal concentration of chlorine needs to be 100 ppm (as stated by the FDA).

NOTE

Follow the directions on the container for proper concentration.

Two main factors contribute to falling chlorine concentrations in a sanitizing solution.

1. **PRODUCT USE** – As the chlorine in the solution is being used, chlorine concentrations fall.
2. **TIME** – As time passes, small amounts of chlorine “evaporate” from the solution. (That is why you can smell it.)

Sanitizing solutions should not be allowed to fall below 100 ppm chlorine. New solutions should be mixed once old solutions become ineffective.

3.4 DISASSEMBLY OF MACHINE PARTS

WARNING

Moving machinery can grab, mangle and dismember. Place the Main Freezer Power Off/On switch in the OFF position before disassembling for cleaning or servicing.

Before using the machine for the first time, complete machine disassembly, cleaning and sanitizing procedures need to be followed. Routine cleaning intervals and procedures must comply with the local and state health codes.

Inspection for worn or broken parts should be made at every disassembly of the machine. All worn or broken parts should be replaced to ensure safety to both the operator and the customer and to maintain good machine performance and a quality product. Check the wear line on the auger flights on a regular basis (Fig. 3-3) and replace as needed. Frequency of cleaning must comply with the local health regulations.



Figure 3-3 Auger Flight Wear

To disassemble the machine, refer to the following steps:

A. DISASSEMBLY OF FRONT DOOR

1. Turn the Main Freezer Power Off/On switch to the OFF position.
2. Remove the knobs on the front door.
3. Remove the front door by pulling it off the studs.
4. Remove the air bleed valve by unscrewing the knob while holding the valve stem from behind. Remove the compression spring and push the air bleed valve through the rear of the front door.
5. Remove the spigots through the bottom of the front door.
6. Remove all o-rings from parts by first wiping off the lubrication using a clean towel. Then squeeze the o-ring upward to form a loop (Fig. 3-4). Roll the o-ring out of the groove.

CAUTION

Do not use any type of sharp object to remove the o-rings.

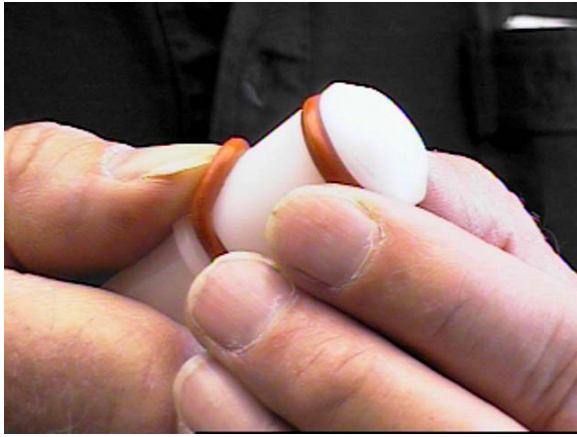

Figure 3-4 Removing O-Ring

B. DISASSEMBLY OF AUGER

1. Remove the front auger support and bushing.
2. Remove the auger assembly from the machine. Pull the auger out of the machine barrel slowly. As the auger is being pulled out, carefully remove each of the plastic flights with springs.
3. Keep the rear of the auger tipped up once it is clear of the freezing cylinder to prevent the rear seal assembly from dropping.
4. Wipe the hex drive anti-seize off of the hex end of the auger with a paper towel. Remove the rear seal assembly (Fig. 3-5).

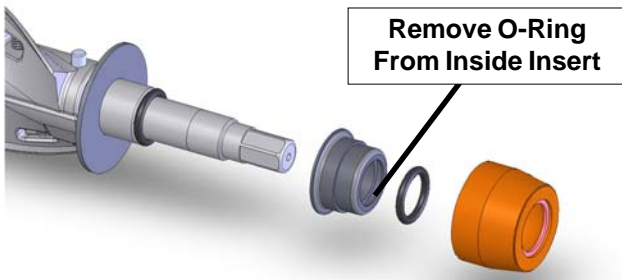

Figure 3-5 Rear Seal Assembly

5. Unscrew the springs from the auger flights.

3.5 CLEANING DISASSEMBLED PARTS

Disassembled machine parts require complete cleaning, sanitizing and air drying before assembling. Local and state health codes will dictate the procedure required. Some state health codes require a four sink process (pre-wash, wash, rinse, sanitize, air dry), while others require a three sink process (without the pre-wash step). The following procedures are a general guideline only. Consult your local and state health codes for the procedures required in your location.

- A. Disassemble all parts. (Refer to Section 3.4 for the disassembly of machine parts.)

- B. Place all front door and auger parts in clean 90° to 110°F (32°C to 43°C) water and wash thoroughly (four sink procedure only).
- C. Place all parts in 90° to 110°F (32°C to 43°C) mild detergent water and wash thoroughly.
- D. Rinse all parts with clean 90° to 110°F (32°C to 43°C) water.
- E. Sanitize all machine parts following procedures outlined below.

3.6 SANITIZING MACHINE PARTS

- A. Use a sanitizer, mixed according to manufacturer's instructions, to provide a 100 parts per million strength solution. Mix sanitizer in quantities of no less than 2 gallons of 90° to 110°F (32°C to 43°C) water. Any sanitizer must be used only in accordance with the manufacturer's instructions.
- B. Place all parts in the sanitizing solution for 5 minutes, then remove and let air dry completely before assembling in machine.

3.7 CLEANING THE MACHINE

The exterior should be kept clean at all times to preserve the luster of the stainless steel. A high grade of stainless steel has been used on the machine to ease cleanup. To remove spilled or dried mix, wash the exterior with 90° to 110°F (32°C to 43°C) soapy water and wipe dry.

Do not use highly abrasive materials, as they will mar the finish. A mild alkaline cleaner is recommended. Use a soft cloth or sponge to apply the cleaner. For best results, wipe with the grain of the steel.

- A. Clean the rear seal surface from inside of the freezing cylinder.
- B. Using sanitizing solution and the large barrel brush provided, sanitize the freezing cylinder by dipping the brush in the sanitizing solution and brushing the inside of the freezing cylinder.
- C. Remove the drip tray by pulling from the front panel. Clean and replace the drip tray.

3.8 ASSEMBLING MACHINE

To assemble the machine parts, refer to the following steps:

NOTICE

Petrol-Gel sanitary lubricant or equivalent must be used when lubrication of machine parts is specified.

NOTICE

The United States Department of Agriculture and the Food and Drug Administration require that lubricants used on food processing equipment be certified for this use. Use lubricants only in accordance with the manufacturer's instructions.

- A. Assemble all o-rings onto parts dry, without lubrication. Then apply a thin film of sanitary lubricant to exposed surfaces of the o-rings.
- B. Lubricate the rear seal area on the auger shaft with a thin layer of sanitary lubricant. Install the rear seal o-ring. Lubricate the outside of the rear seal o-ring with sanitary lubricant.
- C. Install the stainless steel rear seal adapter into the rear seal dry (without lubricant). Lubricate the inside surface of the rear seal adapter, including the adapter o-ring, and install it onto the auger shaft. DO NOT lubricate the outside of the rear seal adapter (Fig. 3-6).

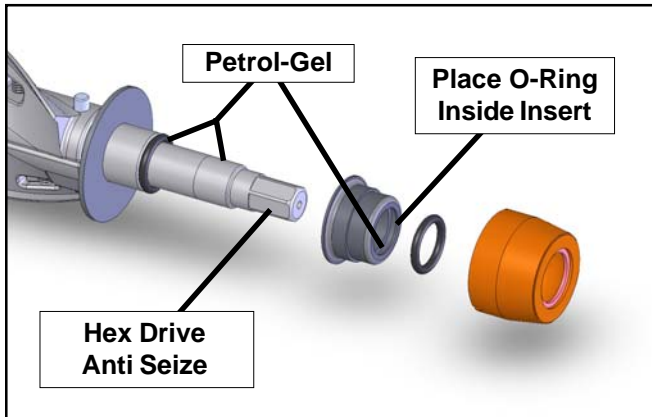

Figure 3-6 Rear Seal Assembly

- D. Lubricate the hex drive end of the auger with a small amount of hex drive anti seize. A small container of anti seize is shipped with the machine.
- E. Screw the springs onto the studs in the plastic flights. The springs must be screwed into the flights completely to provide proper compression.
- F. Install the two plastic flights onto the rear of the auger and insert it part way into the freezing cylinder.
- G. Install the remaining plastic flights, push the auger into the freezing cylinder and rotate slowly until the auger engages the drive shaft.

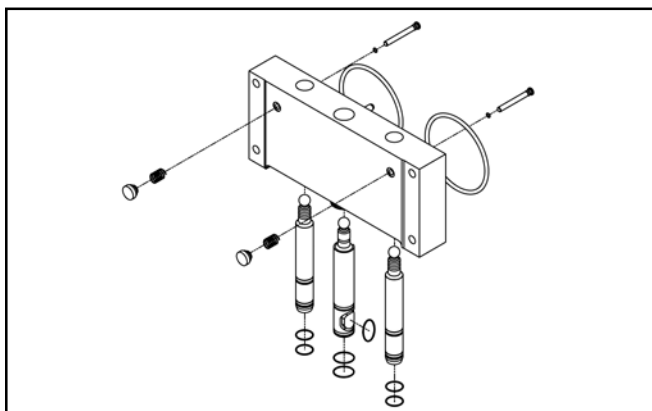

Figure 3-7 Front Door

- H. Apply a thin layer of sanitary lubricant to the inside and outside of the auger support bushing. Install the bushing onto the auger support and install the auger support into the front of the auger. Rotate the auger support so that one leg of the support points straight up.
- H. Assemble the air bleed valve o-ring onto the air bleed valve. Position the o-ring into the groove close to the wide part. Apply a thin film of sanitary lubricant to the o-ring.
- I. Insert the air bleed valve into the back of the front door. Install the compression spring onto the air bleed valve then screw the knob on finger tight.
- J. Apply a thin layer of sanitary lubricant to the o-rings on the spigot body and install the spigot body through the bottom of the front door.
- K. Apply a thin film of sanitary lubricant to the door seal o-ring and fit it into the groove on the rear of the front door.
- M. Place the front door assembly on the mounting studs and the push front door against the machine carefully.
- N. Secure the front door to the machine by placing the knobs on the studs and tightening until finger tight. Do not overtighten. Proper o-ring seal can be observed through the transparent front door.

3.9 SANITIZING

Sanitizing must be done after the machine is clean and just before the machine is filled with mix. Sanitizing the night before is not effective. However, you should always clean the machine and parts after using it.

NOTE

The United States Department of Agriculture and the Food and Drug Administration require that all cleaning and sanitizing solutions used with food processing equipment be certified for this use.

When sanitizing the machine, refer to local sanitary regulations for applicable codes and recommended sanitizing products and procedures. The frequency of sanitizing must comply with local health regulations. Mix sanitizer according to manufacturer's instructions to provide a 100 parts per million strength solution. Mix sanitizer in quantities of no less than 2 gallons of 90°F to 110°F (32°C to 43°C) water. Allow sanitizer to contact the surfaces to be sanitized for 5 minutes. Any sanitizer must be used only in accordance with the manufacturer's instructions.

CAUTION

Risk of Product Damage

Avoid prolonged contact of sanitizer with machine parts. Sanitizer may cause corrosion of stainless steel parts if there is prolonged contact.

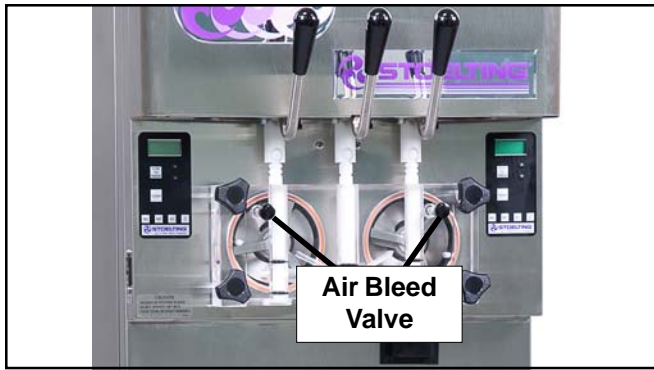

Figure 3-8 Air Bleed Valve

- A. Prepare 2 gallons of sanitizing solution following the manufacturer's instructions. Pour it into a clean container and place the container into the cabinet. Put the mix pick-up tube in the sanitizer.
- B. Place the mix pump switch in the ON position and open the air bleed valve on the front door by pushing the valve in and holding (see Figure 3-8).
- C. Let sanitizing solution fill the freezing cylinder to the air bleed valve. Close the valve by pulling it out to lock it into place.
- D. Place the Main Power OFF/ON and Freezing Cylinder OFF/ON switches in the ON position. Press the CLEAN button.
- E. Check for leaks when the freezing cylinder is first pressurized with sanitizing solution.
 1. Check for leaks at the front door seals.
 2. Check the drain tray located in the front panel for leaks coming from the rear of the rear auger seal.
 3. Check the inside of the cab unit for leaks at the hose connections.
- F. Using a sanitized soft bristle brush (or equivalent) dipped in sanitizing solution, clean the mix container.
- G. After five minutes, open the spigot to expel sanitizing solution. Drain all of the solution from the machine.
- H. When the solution has drained, press the CLEAN button to stop the auger and place the Main Power OFF/ON and Freezing Cylinder OFF/ON switches in the OFF position. Allow the freezing cylinder to drain completely.

The machine is now sanitized and ready for adding mix.

3.10 INITIAL FREEZE DOWN AND OPERATION

Every Stoelting soft serve machine needs to be set on site. The following adjustment will provide optimal product consistency while prolonging product life.

NOTE

The machine is designed for correct operation in ambient temperatures between 50°F and 110°F. Temperatures out of that range may cause refrigeration problems and product quality issues.

A. ADDING MIX

1. Sanitize the machine immediately before use.
2. Make sure the Freezing Cylinder OFF/ON switch is in the OFF position.
3. Fill the mix container in the cab with at least 2.5 gallons of mix.
4. Attach the mix inlet probe to the container and place the container in the refrigerated cab.
5. The mix pump switch is located inside the cab unit. Place it in the ON position.
6. Place a container under the spigot and open the spigot to allow the mix to flush out about 8 ounces (0.23 liters) of sanitizing solution and liquid mix. Close the spigot.
7. Open the air bleed valve on the front door by pressing and holding. Hold the valve open until the mix level in the freezing cylinder is 1/2" from the air bleed valve.

B. PREPARING THE INTELLITEC CONTROL

8. On the IntelliTec control, press and hold the SEL button for 8 seconds. While still holding the SEL button, press the up arrow (↑) button. The LCD will read "DISPLAY".
9. Press the left arrow (←) button once. The display will read "BASIC".
10. Press the up arrow (↑) button once. The display will read "CutOut amps".
11. Press the SET button. A cursor will start blinking under the far right digit.
12. Change the value to 8.0. Press the left arrow (←) button to move the cursor. Press the up arrow (↑) button to increase the digit. When a digit reaches 9, pressing the up arrow (↑) button again will change the value to 0.
13. After entering 8.0, press SET to save this value. The LCD will read "CutOut Set -- OK".
14. Press the SEL button. The LCD will read "CutOut amps 8.0".
15. Press the SEL button twice. The LCD will read "DISPLAY".
16. Press the up arrow (↑) button to navigate to the "°F" and "amps" readings.

C. INITIAL FREEZE DOWN

17. Place the Freezing Cylinder OFF/ON switch in the ON position.
18. Press the PUSH TO FREEZE button.

NOTE

After the drive motor starts, there is a 3-second delay before the compressor starts.

19. As the product freezes, the “amps” value on the display will increase. When it reaches 2.8A, open the spigot, take a 6-8 ounce sample and measure the temperature. For most soft serve mixes, the desired temperature is between 19.0°F and 19.5°F.
20. Draw samples at every increase of 0.2A until reaching the desired consistency and temperature.

NOTE

Show the sample to the customer and make sure it meets their required consistency and temperature.

21. Record the “amps” value.
22. Place the Freezing Cylinder OFF/ON switch in the OFF position.

D. ADJUSTING THE INTELLITEC CONTROL

23. Press the SEL button. The display will read “DISPLAY”.
24. Press the left arrow (←) button once. The display will read “BASIC”.
25. Press the up arrow (↑) button once. The display will read “CutOut amps”.
26. Change the value to the recorded value by pressing the SET button. A cursor will start blinking under the far right digit.
27. Press the left arrow (←) button to move the cursor. Press the up arrow (↑) button to increase the digit. When a digit reaches 9, pressing the up arrow (↑) button again will change the value to 0.
28. Press the SET button to save the value. The LCD will read “CutOut Set -- OK”.
29. Press the SEL button. The LCD will read “CutOut amps” along with the programmed value from the previous step.
30. Press the SEL button three times. The LCD will read “EXITMENU”.
31. Press the up arrow (↑) button to exit the menu.
32. Adjustment to the control is completed.

E. SERVING PRODUCT

33. Place the Freezing Cylinder OFF/ON switch in the ON position.
34. Press the PUSH TO FREEZE button.
35. When the product is at 75% consistency, the display will read “SERVE”.
36. For normal dispensing, move the spigot handle fully open.
37. The machine dispenses product at a reasonable draw rate. If the machine is overdrawn, the result is a soft product or a product that will not dispense

at all. If this occurs, allow the machine to run for approximately 30 seconds before dispensing more product. A dispense rate adjuster is located under the header panel, to the immediate right of the spigot handle. Turning the knob counterclockwise will decrease the dispense rate.

38. Do not operate the machine when the MIX LOW message is displayed. Refill the mix container immediately.

NOTE

The machine has a standby and sleep mode. After a preset number of freezing cycles, it will enter the standby mode (followed by sleep mode) and remain there until someone draws product or presses the PUSH TO FREEZE button. In the sleep mode, the machine will keep the product below 41°F (5°C). Sleep modes do not take the place of cleaning and sanitizing. Federal, State, and local regulatory agencies determine frequency of cleaning and sanitizing.

3.11 NORMAL FREEZE DOWN AND OPERATION

The following section contains the recommended operating procedures for the safe operation of the machine.

- A. Sanitize immediately before use.
- B. Make sure the Freezing Cylinder Off/On switch is in the OFF position.
- C. Fill the storage container in the cab with at least 2.5 gallons of mix.
- D. Attach the mix inlet probe to the container and place the container in the refrigerated cab.
- E. Place the mix pump switch in the ON position.
- F. Place a container under the spigot and open the spigot to allow the mix to flush out about 8 ounces (0.23 liters) of sanitizing solution and liquid mix.
- G. Open the air bleed valve on the front door by pressing and holding. Hold the valve open until the mix level in the freezing cylinder is 1/2” from the air bleed valve.
- H. Place the Freezing Cylinder OFF/ON switch in the ON position.
- I. Press the PUSH TO FREEZE button.

NOTE

After the drive motor starts, there is a 3-second delay before the compressor starts.

- J. When the product is at 75% consistency, the display will read “SERVE”. Open the spigot to dispense product.

- K. The machine dispenses product at a reasonable draw rate. If the machine is overdrawn, the result is a soft product or a product that will not dispense at all. If this occurs, allow the machine to run for approximately 30 seconds before dispensing more product. A dispense rate adjustor is located under the header panel, to the immediate right of the spigot handle. Turning the knob counterclockwise will decrease the dispense rate.
- M. Do not operate the machine when the MIX LOW message is displayed. Refill the mix container immediately.

NOTE

The machine has a standby and sleep mode. After a preset number of freezing cycles, it will enter the standby mode (followed by sleep mode) and remain there until someone draws product or presses the PUSH TO FREEZE button. In the sleep mode, the machine will keep the product below 41°F (5°C). Sleep modes do not take the place of cleaning and sanitizing. Federal, State, and local regulatory agencies determine frequency of cleaning and sanitizing.

3.12 MIX INFORMATION

Mix can vary considerably from one manufacturer to another. Differences in the amount of butterfat content and quantity and quality of other ingredients have a direct bearing on the finished frozen product. A change in machine performance that cannot be explained by a technical problem may be related to the mix.

Proper product serving temperature varies from one manufacturer’s mix to another. Mixes should provide a satisfactory product in the 20°F to 24°F range. Diet and low-carb mixes typically freeze to proper consistency at higher temperatures.

When checking the temperature, stir the thermometer in the frozen product to get an accurate reading.

Old mix, or mix that has been stored at too high a temperature, can result in a finished product that is unsatisfactory. To retard bacteria growth in dairy based mixes, the best storage temperature range is between 33° to 38°F (0.5° to 3.3° C).

3.13 OPERATION OF MIX PUMP

The mix pump switches are located on the back panel. When a pump switch is placed in the ON position, the mix pump motor will start pumping mix into the freezing cylinder. When the set pressure is reached, the mix pump will shut off automatically. When the switch is placed in the OFF position, the mix pump will not operate.

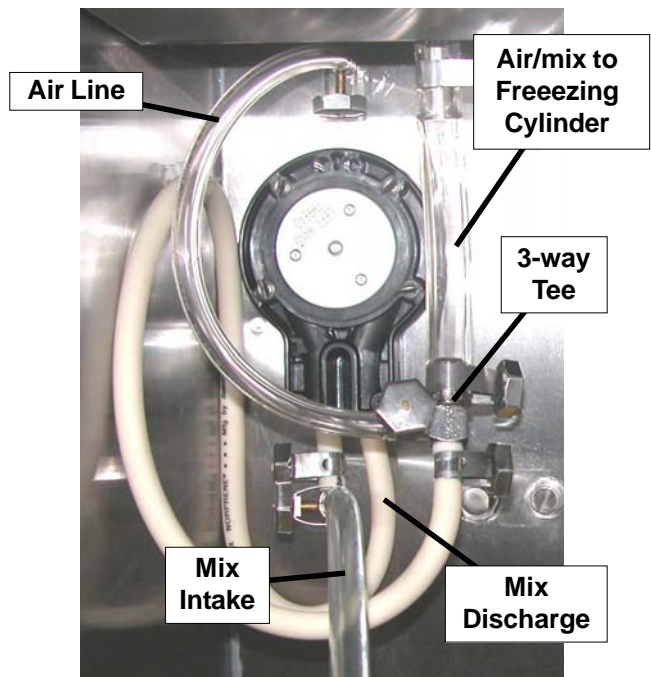

Figure 3-9 Mix Pump Hose Routing

NOTE

The mix pump motor is equipped with an internal overload that will “trip”, disabling the pump when the motor is overloaded. Consult the trouble shooting section for corrective information. The internal overload will automatically reset after cooling. If the condition continues, contact a qualified service person.

- A. **Mix Operation:** The peristaltic mix pump contains one continuous mix pump hose. When looking at the face of the peristaltic mix pump, the left side of the hose is the mix intake or pickup. The right side of the hose is the mix discharge. Mix is drawn up the pickup side of the hose and transferred through the discharge side to the machine (Fig. 3-9).
- B. **Air Operation:** The air compressor operates whenever the peristaltic mix pump is running. Air enters through a check valve on the piston downstroke. The air is discharged through a second check valve, on the piston upstroke. The air and mix join at the tee and then travel to the machine.
- C. The overrun adjustment is preset at the factory. If an adjustment becomes necessary, refer to Section 4.

3.14 MIX PUMP CLEANING

NOTICE

Any cleaning procedure must always be followed by sanitizing before filling machine with mix. (Refer to section 3.3)

The mix pump is approved for CIP (clean in place). It is thoroughly cleaned when the detergent solution is pumped through the machine. We recommend completely disassembling the pump and disconnecting tubing every 14 days for inspection of parts to confirm the CIP has been properly performed. If any residue is detected, clean or replace those parts as outlined below.

- A. Place the Main Power OFF/ON and Freezing Cylinder OFF/ON switches in the ON position and press the CLEAN button. Allow the auger to agitate for 5 to 10 minutes.
- B. Remove the suction tube from the mix container. Open the spigot to remove the mix remaining in the freezing cylinder.
- C. Pump 2 gallons (7.5 liters) of potable water through machine until the water coming out of the spigot is clear.
- D. Pump 2 gallons (7.5 liters) of 90° to 110°F (32°C to 43°C) detergent solution through the machine. The use of soft water is recommended, along with dishwashing detergents such as "Joy", "Dawn", or equivalent.
- E. Place the mix pump switch in the OFF position. Open the spigot to relieve the remaining pressure.
- F. Press the CLEAN button to stop the auger and place the Main Power OFF/ON and Freezing Cylinder OFF/ON switches in the OFF position.

3.15 DISASSEMBLY AND INSPECTION OF REMOVABLE PARTS

Inspection of removable parts should be made whenever maintenance is performed or when the pump requires disassembly.

NOTE

If the mix line or air line is difficult to remove, soften the tubing with a rag soaked in hot water. Hose connections may be sprayed with Haynes Sanitary Lubricant for ease of removal.



WARNING

Hazardous Moving Parts

Revolving pump head can grab, mangle, and cause serious crushing injury. The Main Power Off/On switch must be placed in the OFF position for cleaning and power must be disconnected when disassembling or servicing.



Figure 3-10 Mix Pump Removable Parts

CAUTION

System Under Pressure

Never disconnect hoses from the machine or the pump without first opening the spigot to relieve pressure.

- A. Loosen the clamp and remove the air hose from the pump compressor.
- B. Loosen the clamp and disconnect the mix pump hose. Remove the pickup hose, the mix check valve and the pickup hose adapter (and bag adapter if applicable) as an assembly from the mix container.
- C. Completely disassemble the hose assembly and the check valve (Fig. 3-10). Place hoses, tee, check valve assembly, and pickup hose adapter in 90° to 110°F (32°C to 43°C) mild detergent water and wash thoroughly. Use soft bristle brushes to clean inside of fittings. Rinse all parts in clean 90° to 110°F (32°C to 43°C) water.
- D. Carefully inspect each part for wear or damage. Replace worn or damaged parts.
- E. Wash the feed tube and the air tube in the cabinet with 90° to 110°F detergent water and brushes provided. Rinse with clean, 90° to 110°F water.
- F. Prepare two gallons (7.5 liters) of sanitizing solution using a USDA certified grade sanitizing solution. Sanitize all removed parts. Allow them to air dry.
- G. Check the Hose Service Record decal to determine if a hose reposition or a hose replacement is required.
- H. Reassemble both hose assemblies per the diagram located on the inside of the cab door. Reconnect the assemblies to the pump hose and the discharge hose, using the clamps. (Refer to Section 2.5 Mix Pump).
- I. Sanitize assembled machine as per instructions outlined in Section 3.9.

SECTION 4 MAINTENANCE AND ADJUSTMENTS

4.1 MACHINE ADJUSTMENT

This section is intended to provide maintenance personnel with a general understanding of the machine adjustments. It is recommended that any adjustments in this section be made by a qualified person.

4.2 PRODUCT CONSISTENCY ADJUSTMENT

The operator can adjust product consistency by modifying the Fine Adjustment setting on the membrane switch. This is the only adjustment that can be made by the operator without using a pass code key sequence. Increasing this setting will increase the drive motor amperage cutout and increase product consistency. Follow the instructions below to make fine adjustments to product consistency.

- A. Place the Main Freezer Power switch in the ON position.
- B. Press the SET button on the Control Panel once. Fine Adj will appear on the LCD screen.
- C. Press the up arrow button (↑) until the desired consistency setting is displayed. The higher the number, the firmer the product consistency. The control may be set from 1 to 9. The value increases by 1 each time the up arrow button is pressed. After the value reaches 9, numbering restarts at 0. The 0 setting cannot be set.
- D. Press the SET button once to save the setting and return to the current mode display.



Figure 4-1 Touchpad

4.3 LOCKING THE CONTROL PANEL

The IntelliTec control has a tamper proof mode to prevent unauthorized use. When set, all buttons on the control panel are disabled. Follow the instructions below to lock the control panel

- A. Press and hold the PUSH TO FREEZE button for at least 5 seconds.
- B. While still holding the PUSH TO FREEZE button, press the CLEAN button once.
- C. Release both buttons. An asterisk (*) will appear on the bottom line of the display, indicating that the control is in the lock out mode.

NOTE:

Repeat steps A, B, and C to unlock the control panel.

4.4 OBTAINING READINGS AND MODIFYING SETTINGS (SERVICE PERSONNEL ONLY)

Readings and settings on the IntelliTec control are accessed through the IntelliTec control menu settings. Locating machine readings and system function settings are done using the up arrow (↑) and left arrow (←) buttons on the membrane switch. A printed IntelliTec Menu Settings sheet is located in the information pouch behind the header panel.

IntelliTec Control Readings

To obtain machine readings, locate the value on the machine's menu settings sheet and follow the steps below.

- A. Press and hold the SEL button for 8 seconds. While still holding the SEL button, press the up arrow button (↑). The LCD screen will read DISPLAY.
- B. Release both buttons.
- C. Press the up arrow button (↑) to navigate to the correct reading under DISPLAY or press the left arrow (←) button to navigate to the ERRCODES menu.
- D. Press the up arrow (↑) and left arrow (←) buttons to navigate through the rest of the readings as needed.
- E. When all readings have been obtained, press the up arrow button (↑) from ExitMenu to return to the current mode display.

Modifying Control Settings

To change the value of a system function, locate the function on the IntelliTec Settings Menu and follow the steps below.

IMPORTANT:

Before making changes to any settings, record the original values. If the setting changes do not achieve desired results, return settings to their original values.

- A. Press and hold the SEL button for 8 seconds. While still holding the SEL button, press the up arrow button (↑). The LCD Screen will read DISPLAY.
- B. Release both buttons.
- C. Press the left arrow button (←) to get to the correct menu (Basic, Advanced, or Storage).
- D. Press the up arrow button (↑) to navigate to the value that needs to be changed.
- E. Press the SET button to enter the edit mode.
- F. Press the up arrow button (↑) to change the setting.
- G. Press the SET button to save the setting and exit the edit mode.
- H. Press the up arrow (↑) and the left arrow (←) buttons to navigate through the rest of the settings as needed.
- I. When all changes have been completed, press the up arrow button (↑) from ExitMenu to return to the current mode display.

4.5 READINGS (SERVICE PERSONNEL ONLY)

The IntelliTec control continuously monitors and records temperatures, voltages, amps, and error code details. Each reading is beneficial to service personnel when troubleshooting.

DISPLAY READINGS

Following are the readings available under the DISPLAY menu:

Cabinet

The temperature of the cab is constantly monitored by the IntelliTec control.

Cycles (count)

This reading counts down the number of cycles in the current "Serve Mode". The starting value is dependant upon the Cycles setting on the IntelliTec control.

°F and amps

Suction line temperature on the freezing cylinder and drive motor amps are available on the same screen to assist with setup and troubleshooting.

Aux. Temp (°F)

This reading provides the ambient temperature around the IntelliTec control board.

Supply V (VAC)

The input voltage is recorded.

ERROR CODE READINGS

The following details are recorded under the ERRCODES menu for each of the last 25 error codes received:

Err1 (hours)

A timer begins when an error occurs. The timer records the number of hours since the error occurred. If power to the machine is interrupted, the timer will stop until power has been restored.

°F and amps

The suction gas temperature on the freezing cylinder and the drive motor amps are recorded at the time of the error.

Aux. Temp (°F)

Ambient temperature of the IntelliTec control board is recorded at the time of the error.

Str (°F)

The storage temperature is recorded at the time of the error.

VAC and Mode

The input voltage and mode at which the error occurred are recorded. Following are descriptions of each mode:

Mode	Description
0	Start of freezing cycle
1	Compressor and drive motor on
2	Stir Cycle
3	Compressor off
4	"Standby Mode"
5	"Sleep 1 Mode"
6	"Sleep 2 Mode"
7	"Clean Mode"
8	Startup
9	Storage only refrigeration
10	Freezing cycle is shut down
11	Door safety switch triggered
12	High pressure cutout

Up Time (hours)

This value is a record of the total time the machine has been in service. If power is interrupted, the timer will stop until power is restored. This timer does not reset.

4.6 ADJUSTMENTS (SERVICE PERSONNEL ONLY)

The following adjustments directly affect product consistency and length of time in "Serve Mode". The default settings have been created using a 5% milkfat soft serve mix and provide optimal product consistency while prolonging product life.

CutOut (amps)

The CutOut value needs to be adjusted to product requirements. To properly set the CutOut value, during startup navigate to the "°F" and "amps" values under the Display menu (Refer to Section 2.3), start the machine and freeze the product to the desired consistency. Monitor consistency by taking a 6-8 ounce sample at each change of the "amps" display. When the desired consistency has been reached, record the temperature and amps, and change the CutOut value to the recorded amps value.

Cut In T (°F)

After the consistency value has been determined, the Cut In T value can be adjusted. This value along with the CutOut value determines the range of temperatures (or "temperature window") of the product. Decreasing the temperature decreases the temperature window and shortens the length of freezing cycles. This creates a greater chance of product breakdown by stirring the product often. Increasing the Cut In T increases the temperature window which decreases freezing cycles and increases the chance of heat shock within the product.

Cycles (count)

This setting determines the number of freezing cycles during "Serve Mode". Increasing the value will increase the total time in "Serve Mode". Factory default is 20 cycles. This results in "Serve Mode" lasting between 45 minutes and 2-1/2 hours without the PUSH TO FREEZE button being pressed or a spigot handle being pulled. If the PUSH TO FREEZE button is pressed or the spigot handle is pulled at any time during "Serve Mode", the Cycles count will reset.

4.7 OTHER SETTINGS (SERVICE PERSONNEL ONLY)

Changing any setting on the IntelliTec control will alter machine operation and affect the product temperature, consistency, or life. Refer to the IntelliTec Control System Settings sheet located in the information pouch behind the right panel of the machine. If any of the following settings on the IntelliTec control differ from the System Settings sheet, it is recommended to revert those settings to factory defaults.

Refriger

The options available for this setting are None, 1 Hopper, 2 Hopper, and Cabinet. Changing this setting changes how the control handles the storage refrigeration cycle. The left control must always be set to Cabinet and the right control must be set to None.

CabCutIn (°F)

If the Refriger value is set to Cabinet, this setting determines the temperature at which the refrigeration cycle starts. If None, 1 Hopper, or 2 Hopper is selected for the Refriger setting, CabCutIn will not be shown on the IntelliTec menu.

CabCtOut (°F)

If the Refriger value is set to Cabinet, this setting determines the temperature at which the refrigeration cycle stops. If None, 1 Hopper, or 2 Hopper is selected for the Refriger setting, CabCtOut will not be shown on the IntelliTec menu.

4.8 OVERRUN ADJUSTMENT

The product, when served, is a combination of air and mix. Overrun is a measure of the amount of air blended into the mix.

Overrun can be expressed in terms of the amount of weight loss for a given volume. For example, if a pint of liquid mix weighs 18 ounces and a pint of frozen product with air added weighs 12 ounces, the overrun is said to be 50 percent: $18 \text{ oz.} - 12 \text{ oz.} = 6 \text{ oz.}$, $(6/12) \times 100 = 50\%$

The overrun can be checked by placing a one pint container on an ice cream scale and zeroing out the scale. Then fill a one pint container with frozen product. The container should be filled over the top and leveled with a straightedge. The product should not contain any air pockets. When weighed on an ice cream scale, one pint of product should weigh 12 to 13 ounces.

The mix pump has been preset at the factory to produce a product with approximately 40% overrun. Because of differences in mix formulation, temperatures and barometric pressure, this figure may vary. It will be necessary for approximately 2 gallons of mix to be pumped through the machine before overrun changes in the product are noticeable.

Overrun is controlled by the length of the air compressor piston stroke within the piston cylinder. Lengthening the stroke within the cylinder will increase overrun. Conversely, shortening the stroke will decrease overrun. To perform an overrun adjustment, refer to the following procedure:

- A. Turn the mix pump switch to the OFF position. Disconnect power sources/circuit breakers.
- B. Remove the lower front panel from the machine.
- C. On the air compressor side of the pump, locate the long/slender piston rocking arm. The rocking arm downward travel is limited by a stationery cam. On the face of the cam there is an overrun setting indicator plate numbered 3 through 8 and an adjustment knob (Fig. 4-2).

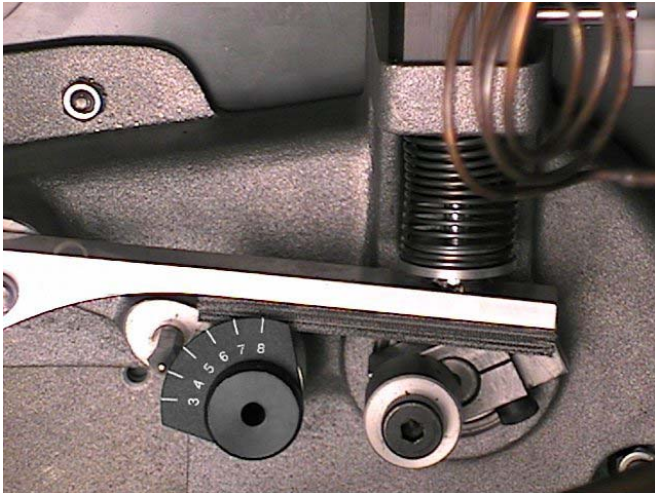

Figure 4-2 Overrun Adjustment

- D. The overrun setting is indicated by a pin.
- E. To adjust overrun, loosen the allen-head screw (located within the center of the adjustment knob) with the 5/32" allen wrench provided. Rotate the adjustment knob counterclockwise to a higher number for higher overrun, or clockwise to a lower number for lower overrun. Each number multiplied by 10 represents the overrun percentage (i.e. setting 4 = 40% overrun).
- F. Tighten the allen screw, then place the wrench back in its clip. Replace the lower back panel and secure with the four screws. Turn the mix pump power switch to the ON position.

4.9 MIX PUMP HOSE REPOSITION

Mix pump hose must be repositioned every 800 gallons of mix pumped or every 2 weeks. Failure to reposition the hose will result in reduced mix pump liquid capacity, dispense stoppage, popping, and possible mix pump hose leakage. Follow the steps below to reposition the hose:

- A. Run cleaning solution through pump.
- B. Turn the pump off and relieve any pressure by opening the spigot.
- C. Grasp the pickup hose end of the mix pump hose with one hand and turn the pump on. Pull down on the pickup hose end until 12 to 14 inches of tubing has fed through the pump then turn the pump off (Fig. 4-3).

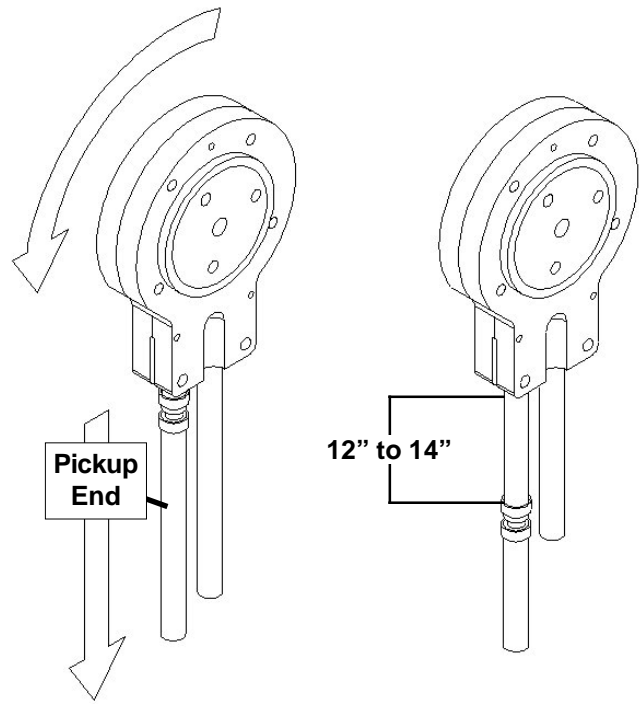

Figure 4-3 Pump Hose Reposition

- D. Loosen the small clamp at the pick-up hose adapter and disconnect the mix pump hose.
- E. Cut 7-1/2 inches off the end of the mix pump hose.
- F. Reconnect the mix pump hose to the adapter.
- G. Continue normal operation. Mix hose will automatically reposition itself with the adapter near the black cover.

NOTE

Each hose is long enough for 3 repositions before replacement is required.

4.10 MIX PUMP HOSE REPLACEMENT

Mix pump hose must be replaced when tubing cannot be further repositioned (every four to eight weeks). Failure to comply will result in hose failure and possible pump damage. Follow the steps below to replace the hose:

- A. Run cleaning solution through pump.
- B. Turn the pump off and relieve any pressure by opening the spigot.
- C. Disconnect the mix pump hose at each end.
- D. Grasp the discharge hose end with one hand and turn the pump on. Pull down on the hose until all of the remaining hose is removed from the pump. Turn pump off.
- E. Rotate pump roller assembly so one roller is at the 6:00 position.
- F. Use a brush that fits in the opening and clean the pump roller assembly, first with detergent water and then clear water.

- G. Connect the new mix pump hose to the pickup hose adapter using the small clamp.
- H. Feed one end of the mix pump hose into the pickup hose side (left) of the black cover.

NOTE

Feed the tube into the clamp so the natural curve of the tube is towards the outside of the black cover. This prevents the hose from looping around the black cover twice.

- I. Gently push the hose into the black cover until it begins to feed.
- J. Allow the hose to feed itself through the pump until about 6" (15cm) remains on the entering side.
- K. Turn pump off.
- L. Connect the mix pump hose to the elbow fitting (located on the left side of the mix line manifold) using a small hose clamp. Be careful not to twist the mix hose.
- M. Turn the pump on.
- N. Allow the remaining 6" (15cm) of tubing to feed through the pump until the hose adapter prevents further feeding.
- O. Turn the pump off.

CAUTION
<p>Risk of Product Damage Air/Mix Tee must remain below the black cover clamp. If the Tee is above the pump, the mix may drain into the air compressor, resulting in pump damage.</p>

- P. Connect the free end of the mix pump hose to the 3-way Tee. When all connections are complete, the 3-way Tee must be lower than the black pump housing.
- Q. The pump is now ready to sanitize.

4.11 CAB TEMPERATURE ADJUSTMENT

Cab temperature is monitored and controlled by two settings on the IntelliTec control: CabCutIn and CabCtOut. The cut in value determines the temperature at which the refrigeration cycle starts. The cut out setting determines when the cycle stops. To change the CabCutIn or CabCtOut, follow the steps below:

- A. Press and hold SEL button for 8 seconds. While still holding the SEL button, press the up arrow button (↑). The LCD Screen will read "Display".
- B. Release both buttons.
- C. Press the left arrow button (←) three (3) times to navigate to the Storage menu.
- D. Press the up arrow button (↑) once to navigate to the CabCutIn value. Record this value.

IMPORTANT:

Before making changes to any settings, record the original values. If the setting changes do not achieve desired results, return settings to their original values.

- E. Press SET button to enter edit mode.
- F. Press the up arrow button (↑) to increase the number to the value required. The value increases by 1 each time the up arrow button (↑) is pressed. After the value reaches 9, numbering restarts at 0.
- G. Press SET button to save the setting and exit the edit mode.
- H. Press the up arrow button (↑) once to navigate to the CabCtOut value. Record this value.
- I. Press SET button to enter edit mode.
- J. Press the up arrow button (↑) to increase the number to the value required. The value increases by 1 each time the up arrow button (↑) is pressed. After the value reaches 9, numbering restarts at 0.
- K. Press SET button to save the setting and exit the edit mode.
- L. Press the up arrow (↑) and left arrow (←) buttons to navigate to ExitMenu.
- M. Press the up arrow button (↑) from ExitMenu to return to the Mode Screen.
- N. Locate the Specification Sheet for SU412 Control behind the header panel and record the new values on this sheet.

4.12 DRIVE BELT TENSION ADJUSTMENT

- A. Remove a side panel and the back panel.

 WARNING
<p>Hazardous Voltage The Main Freezer Power switch must be placed in the OFF position when disassembling for servicing. The freezer must be disconnected from electrical supply before removing any access panel. Failure to disconnect power before servicing could result in death or serious injury.</p>

- B. Press firmly on one belt.
- C. When the tension is properly adjusted, the belt will depress the approximate width of the belt with the pressure of a finger.
- D. If an adjustment is necessary, loosen the four motor plate retaining nuts, adjust belt tension then retighten the four nuts.

NOTE

Belt life will be increased if new drive belts are tightened after two or three weeks of operation.

4.13 CONDENSER CLEANING (AIR-COOLED MACHINES)

The condenser requires periodic cleaning. To clean the condenser, refer to the following steps:



WARNING

Hazardous Voltage

The Main Freezer Power switch must be placed in the OFF position when disassembling for servicing. The freezer must be disconnected from electrical supply before removing any access panel. Failure to disconnect power before servicing could result in death or serious injury.

- A. Remove the side panel and pull out the condenser filter. (Fig. 4-4)
- B. Visually inspect the condenser filter for dirt.
- C. If the condenser filter is dirty, vacuum or brush it clean. Rinse it with clean water and allow it to dry before replacing it on the machine.

NOTE

If the condenser is not kept clean, refrigeration efficiency will be lost.

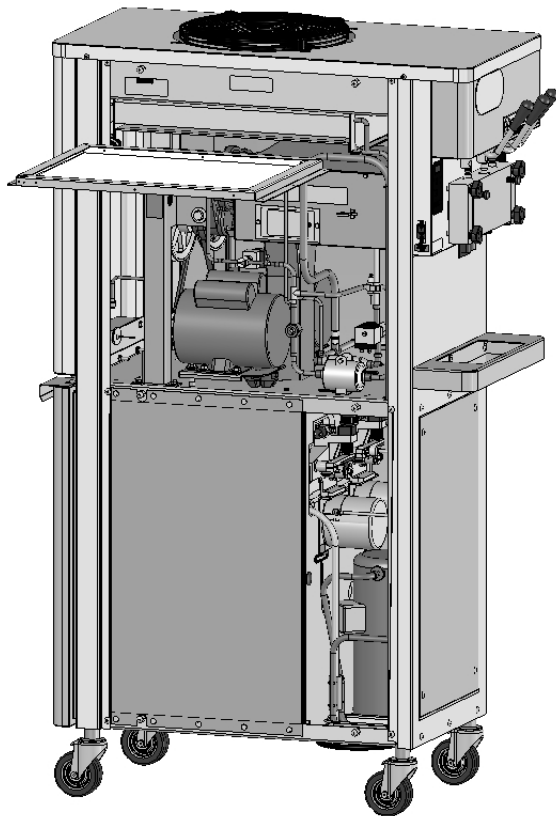

Figure 4-4 Removing Condenser Filter

4.14 PREVENTATIVE MAINTENANCE

It is recommended that a preventative maintenance schedule be followed to keep the machine clean and operating properly. The following steps are suggested as a preventative maintenance guide.

The United States Department of Agriculture and the Food and Drug Administration require that lubricants used in food zones be certified for this use. Use lubricants only in accordance with the manufacturer's instructions.

- A. Daily checks
Check for any unusual noise or condition and repair immediately.
- B. Monthly checks
 1. Check drive belts for wear and tighten belts if necessary. (Refer to section 4.12)
 2. Check the condenser filter for dirt. (Refer to section 4.13).

4.15 EXTENDED STORAGE

Refer to the following steps for winterizing the machine or for storing the machine over any long period.

- A. Clean all of the parts that come in contact with mix thoroughly with warm detergent. Rinse in clear water and dry all parts. Do not sanitize.

NOTE

Do not let cleaning solution stand in freezing cylinder or mix pump during the shutdown period.

- B. Remove, disassemble, and clean the front door, auger shaft, and mix pump. Leave disassembled during the shutdown period.
- C. Place the plastic auger flights in a plastic bag with a moist paper towel. This will prevent the flights from becoming brittle if exposed to dry air over an extended period (over 30 days).
- D. For water-cooled machines that are left in unheated buildings, or buildings subject to freezing, the water must be shut off and disconnected. Disconnect the fittings at the water inlet and the water outlet lines of the machine. The fittings are located at the rear of the machine. Run the compressor for 2 - 3 minutes to open the water valve. Blow out all the water, first through the water inlet, then through the water outlet lines with air or carbon dioxide. Drain the water supply line coming to the machine.
- E. Place the Pump OFF/ON switch and the Main Freezer Power OFF/ON switch in the OFF position.
- F. Disconnect the machine from the source of the electrical supply in the building.

SECTION 5 TROUBLESHOOTING

5.1 ERROR CODES

When the machine experiences a problem, one of the following error codes will be displayed on the control panel. Each error code directs you to the system location of the malfunction.

ERROR CODE MALFUNCTION

1	Soft
2	High Torque
3	Extended Run Time
4	Clean
5	Barrel Sensor
6	Hopper Sensor
7	Drive Motor
8	Cab Sensor
9	High Pressure Cutout
10	Auxiliary Sensor
11	Low Temperature

To return the machine to normal operation, any error causing condition must be corrected and the Freezing Cylinder Off-On switch must be placed in the Off position and back in the On position before the affected side of the machine will return to normal operation.

5.2 TROUBLESHOOTING - ERROR CODES

Error Code 1 - Soft Error

The Soft Error (E1) is an internal control board error that is logged for future analysis. The refrigeration is never stopped and the machine will continue to operate normally.

Error Code 2 - High Torque

If the control panel displays a High Torque Error (E2), the drive motor is running at a high load for 10 or more seconds. This may be due to the product consistency adjustment being set too high. Place the Main Power OFF/ON switch in the OFF position, wait until the product in the freezing cylinder thaws to a reasonably soft consistency and return the Main Power switch to the ON position. Follow the steps in section 3 to reduce product consistency by a few levels. If the error persists, contact your authorized Stoelting Distributor for further assistance.

Error Code 3 - Run Time

The Run Time Error (E3) occurs when the compressor runs continuously for an extended period. This error is generally caused by very low mix levels in the machine's mix container or from product breakdown. Another common cause results from a restriction preventing mix from entering the freezing cylinder. Check the mix in the cabinet. If the level mix is low, add mix. If there is a possibility that the mix is broken down, clean and sanitize the machine and replace the mix with fresh product.

Ice crystals in the liquid mix container can clog the mix inlet system and prevent mix from entering the freezing cylinder. Thoroughly thaw mix per manufacturer's recommendations. To check for ice crystals, pour a small amount of product in the mix container through a clean and sanitized sieve or strainer. If ice crystals are in the mix, check the temperature of the walk-in cooler where the mix is stored or the temperature of the machine's cabinet.

Check the condition of the neoprene hose running through the mix pump head. If it shows signs of wear, rotate or replace it as outlined in Section 3.

In air cooled machines, the Run Time Error may indicate that airflow within the machine has reduced or stopped. Check the sides and top of the machine for anything that would restrict airflow.

If the error persists after attempting to clear it, contact your Authorized Stoelting Distributor for further assistance.

Error Code 4 - Clean

If the machine is left in the Clean Mode for more than 20 minutes, the control panel will display a Clean Error (Error 04). This condition does not reflect a problem with the machine itself. The Clean Error has been programmed into the controller as a safeguard to protect the machine from potential damage caused by the machine being accidentally left in "Clean Mode". The control will attempt to restart itself after 5 minutes. The display will then flash and read Restart. To immediately clear the Clean Error, place the Main Power Off-On switch in the Off position and back in the On position. After restarting the machine, a refrigeration cycle will begin. This protects the product in case the clean button was pressed by mistake.

Error Code 5 - Freezing Cylinder Sensor

The Freezing Cylinder Sensor Error (E5) indicates a failure of the barrel sensor or if the sensor is out of range. If the control panel displays an E5, place the Freezing Cylinder Off-On switch in the Off position and back in the On position. If the error persists, contact your Authorized Stoelting Distributor for further assistance.

NOTE

When the machine encounters a Freezing Cylinder Sensor Error, the machine will continue to run using preset timers. This mode will allow the operator to continue serving product until the machine can be serviced.

Error Code 6 - Hopper Sensor (single hopper machines)

The Hopper Sensor Error (E6) will not occur on the O431 machine.

Error Code 7 - Drive Motor

If the control panel displays a Drive Motor Error (E7), the control does not sense the drive motor. Place the Freezing Cylinder Off-On switch in the Off position and back in the On position. If the error persists, contact your Authorized Stoelting Distributor for further assistance.

Error Code 8 - Cab Sensor

A Cab Sensor Error (E8) indicates a cabinet temperature sensor failure or. This error will also appear if the sensor is out of range. If the control panel displays an E8, place the Freezing Cylinder Off-On switch in the Off position and back in the On position. If the error persists, contact your Authorized Stoelting Distributor for further assistance.

Error Code 9 - High Pressure Cutout

High Pressure Cutout Errors (E9) are usually caused by a dirty or inefficient condenser.

In air cooled condenser models, check for proper air clearance around the machine.

In water cooled condenser models check for proper water flow.

If the error persists, contact your Authorized Stoelting Distributor for further assistance.

Error Code 10 - Auxiliary Sensor

An Auxiliary Temperature Sensor Error (E10) occurs if the temperature sensor on the control board fails. Place the Freezing Cylinder Off-On switch in the Off position and back in the On position. If the error persists, contact your Authorized Stoelting Distributor for further assistance.

Error Code 11 - Low Temperature

The Low Temperature Error (E11) occurs when there is a very low temperature in the freezing cylinder. Although the machine will not shut down, the active freezing cycle will immediately end. This error usually occurs when the machine continues to run in a low mix condition or if the machine runs out of mix. The product towards the front of the freezing cylinder tends to freeze solid. When the temperature on the freezing cylinder lowers to the preset value, the IntelliTec control will display an E11.

ALTERNATING FLASHING CONTROL PANEL LIGHTS

The display panel lights will flash in an alternating sequence under any error codes. Clear the error and place the Freezing Cylinder Off-On switch in the Off position and back in the On position.

5.3 TROUBLESHOOTING - FREEZER

PROBLEM	POSSIBLE CAUSE	REMEDY
Drive motor (auger) "kicks-out", or does not run.	<ol style="list-style-type: none"> 1. Power to machine is off. 2. Low line voltage. 3. Product too hard. 4. Front door not installed securely. 	<ol style="list-style-type: none"> 1. Check power to machine. 2. Check, must be $\pm 10\%$ of nameplate voltage. 3. Raise overrun. (See Section 4.8) 4. Install front door securely.
Compressor does not operate.	<ol style="list-style-type: none"> 1. Power to machine if off. 2. Low line voltage. 3. Compressor internal overload is cut-out. 4. Front door not installed securely. 	<ol style="list-style-type: none"> 1. Check power to machine. 2. Check, must be $\pm 10\%$ of nameplate voltage. 3. Check condenser (air cooled)(See Sect. 4.13), or water supply (water cooled). 4. Install front door securely.
Product too soft.	<ol style="list-style-type: none"> 1. CutOut setting is too low 2. Product break down. 	<ol style="list-style-type: none"> 1. Adjust CutOut setting to match product requirements.(See Section 3.10) 2. Fill with fresh product.
Freeze-up. (Product will not dispense easily.)	<ol style="list-style-type: none"> 1. CutOut setting is too high. 2. Low overrun setting. 3. Low pump pressure. 4. Large air pocket in barrel. 5. Auger turning counter-clockwise. 	<ol style="list-style-type: none"> 1. Adjust CutOut setting to match product requirements.(See Section 3.10) 2. Raise overrun. (See Section 4.8) 3. Check pump pressure. 4. Purge air from barrel. 5. Change rotation to clockwise.
Rear auger seal leaks.	<ol style="list-style-type: none"> 1. Seal missing or installed wrong. 2. Rear seal o-ring missing, broken or not lubricated. 3. Worn or scratched shaft. 	<ol style="list-style-type: none"> 1. Install correctly. (See Section 3.8) 2. Inspect for breakage and lubricate properly (See Section 3.8) 3. Replace shaft.
Spigot leaks.	<ol style="list-style-type: none"> 1. Spigot parts are not lubricated. 2. Chipped or worn o-rings. 3. O-rings on spigot installed wrong. 4. Nicks or scratched on front door where spigot is located. 	<ol style="list-style-type: none"> 1. Lubricate. (See Section 3.13) 2. Replace o-rings. 3. Remove spigot and check o-rings. 4. Replace front door.
Drive belts slipping or squealing.	<ol style="list-style-type: none"> 1. Drive belt tension not correct. 2. Worn belt(s). 3. Low overrun. 	<ol style="list-style-type: none"> 1. Adjust belt tension. (See Section 4.12) 2. Replace belts. 3. Check for air leak.
Mix temperature too warm in cab.	<ol style="list-style-type: none"> 1. Temperature control set too warm. 2. Cab door is open. 	<ol style="list-style-type: none"> 1. Decrease CabCtOut and CabCutIn (See Section 4.7) 2. Close the cab door.
Mix temperature too cold in cab.	<ol style="list-style-type: none"> 1. Temperature control set too cold. 	<ol style="list-style-type: none"> 1. Increase CabCtOut and CabCutIn (See Section 4.7)

5.4 TROUBLESHOOTING - MIX PUMP

PROBLEM	POSSIBLE CAUSE	REMEDY
<p>Pump motor does not run.</p>	<ol style="list-style-type: none"> 1. Power to pump is off. 2. Low voltage. 3. Mix pump hose jammed inside black cover/clamp. 4. Pump motor overloaded. 5. Pressure switch on pump is defective. 6. Defective motor/capacitor. 7. Defective toggle switch. 	<ol style="list-style-type: none"> 1. Supply power to pump. 2. Check for low voltage. 3. Disconnect pump from power source. Remove four cover/clamp thumb screws. Separate cover/clamp halves and remove outer half. Remove jammed hose. Clean and re-install cover/clamp and tighten four thumb screws securely. Allow motor thermal overload to reset. 4. Allow internal thermal overload to reset; determine overload cause and repair. 5. Check mechanical operation and continuity of pressure switch. 6. Check motor amperage draw and/or capacitor. Replace motor or capacitor. 7. Check continuity; repair or replace.
<p>Pump operates but cylinder will not fill.</p>	<p>Note 1: A properly working pump will fill an 8 oz. cup with mix in about 9 seconds.</p> <p>Note 2: Immediately after a bag change the pump may be unable to reestablish it's prime with the system at operating pressure. In this case, turn the pump off. Draw 2-3 pints to reduce system pressure to zero. Turn pump on. Purge remaining air in mix bag and pick-up hose.</p> <p>Important: before connecting the pick-up hose to the mix bag, remove as much air from the mix bag as possible.</p> <ol style="list-style-type: none"> 1. Out of Mix. 2. Mix pump hose kinked inside black cover/clamp. 3. Hoses assembled incorrectly. 4. Mix pump hose service life is exceeded. 5. Mix pump hose not connected to machine. 6. Ice crystals in mix. 7. Mix bag drawn against adapter. 8. Foreign objects in mix. 9. Check valve is backwards. 	<ol style="list-style-type: none"> 1. Replenish mix supply. 2. Disconnect pump from power source. Remove four cover/clamp thumb screws. Separate cover/clamp halves and remove outer half. Remove jammed hose. Clean and re-install cover/clamp and tighten four thumb screws securely. Allow motor thermal overload to reset. 3. Refer to diagram for correct hose connections. 4. Reposition/replace mix pump hose. See Section 4.9 5. Connect mix pump hose to machine. 6. Completely thaw mix prior to use. 7. Ensure bag is clear of pick-up tube. 8. Clear blockage. Use fresh mix. 9. Observe flow arrow for proper orientation.
<p>Overrun too low or no overrun.</p>	<ol style="list-style-type: none"> 1. Overrun setting too low. 2. Air leak. 3. Air compressor not pumping air. 4. Air check valve in backwards. 	<ol style="list-style-type: none"> 1. Increase overrun setting. 2. Tighten all hose clamps. 3. Contact local Stoelting Distributor. 4. Check arrow for direction of flow.

5.4 TROUBLESHOOTING - MIX PUMP (CONTINUED)

PROBLEM	POSSIBLE CAUSE	REMEDY
Overrun too high.	<ol style="list-style-type: none"> Mix pump hose service life is exceeded. Out of mix. Overrun setting too high. Pick-up leg of mix pump hose is collapsing. 	<ol style="list-style-type: none"> Reposition/replace mix pump hose. Replenish mix supply. Decrease overrun setting. Reposition hose.
Replacement mix pump hose won't feed through pump.	<ol style="list-style-type: none"> Feeding hose into discharge hole of mix pump cover. Hose ends not cut squarely. Force feeding too quickly. Pump motor not running. 	<ol style="list-style-type: none"> Feed hose into suction side of cover. Carefully cut hose end off squarely (no tails). Gently and slowly assist feeding of hose up into pick-up hose side of cover. Turn on motor switch.
Air exiting mix pick-up hose.	<ol style="list-style-type: none"> Pickup tube check valve missing. 	<ol style="list-style-type: none"> Contact local Stoelting Distributor.
Dispensed product air "pops"	<ol style="list-style-type: none"> Overrun setting too high. Mix pump hose service life is exceeded. Overdrawing the machine's capacity. Recent low mix condition. 	<ol style="list-style-type: none"> Decrease overrun setting. Reposition/replace mix pump hose. Reduce dispense rate. Open spigot fully and allow excess air to escape.
Mix leakage from pump.	CAUTION: To prevent mix pump damage from dried mix deposits, immediately disassemble and clean pump.	
	<ol style="list-style-type: none"> Mix pump hose service life is exceeded. 	<ol style="list-style-type: none"> Remove mix pump hose. Disconnect pump from power source. Remove mix pump cover/clamp. Clean the rollers a small amount of soapy water. Clean mix from pump. See Section 4.2 for hose replacement.
Pump is noisy/squeaking.	<p>Note: The action of the air compressor rocking arm creates a repetitive clicking sound during operation. This is normal.</p> <p>Note: The peristaltic mix pump has three squeeze rollers that use self lubricating bearings. If squeaking exists with the mix pump hose in place and stops with the hose removed, the squeeze roller bearings can be lubricated using a silicone based spray. Remove the mix pump hose. Disconnect pump from electrical power. Remove four cover/clamp thumbscrews. Remove entire cover/clamp as one unit. Spray silicone based lubricant on each end of each squeeze roller. Spin rollers to work lubricant into bearings. Repeat as needed.</p> <p>Caution: Do not use cleaning/dissolving type lubricants like wd-40. These lubricants are not bearing friendly and will accelerate bearing wear.</p>	
Mix in air hoses.	<ol style="list-style-type: none"> Air/mix tee above black cover/clamp. Air leak. Mix hose on wrong air/mix tee fitting. Pressure control manifold o-ring leak. 	<ol style="list-style-type: none"> Air/mix tee must be below black cover/clamp. Tighten all hose clamps. Refer to diagram for correct hose connections. Check o-ring and manifold; replace as required.

SECTION 6 REPLACEMENT PARTS

6.1 BRUSHES, DECALS AND LUBRICATION

Part	Description	Quantity
208135	Brush - 4" X 8" X 16" (Barrel)	1
208380	Brush - 1/4" X 3" X 14"	1
208387	Brush - 1/2" X 5" X 24"	1
208465	Brush - 1" X 3-1/2" X 18"	1
208467	Brush - 3/8" X 1" X 5"	1
324105	Decal - Caution Electrical Shock	3
324106	Decal - Caution Electrical Wiring Materials	1
324107	Decal - Caution Hazardous Moving Parts	2
324141	Decal - Caution Rotating Blades	1
324151	Decal - Field Connections	1
324158	Decal - Copper Conductors Only	1
324208	Decal - Attention Refrigerant Leak Check	2
324346	Decal - Caution Hazardous Moving Parts	2
324509	Decal - Cleaning Instructions	1
324566	Decal - Wired According To	1
324584	Decal - Adequate Ventilation 3"	2
324594	Decal - Attention Heat Sensitive	2
324686	Decal - Danger Automatic Start	2
324803	Decal - Domed Stoelting Logo (Large) (Header Panel)	1
324804	Decal - Domed Stoelting Swirl (Header Panel)	1
324825	Decal - Main Freezer Power	1
324826	Decal - Cab Off	1
324827	Decal - Freezing Cylinder	2
508048	Lubricant - Spline (2 oz Squeeze Tube)	1
508135	Petrol Gel - 4 oz Tube	1

6.2 SPIGOT EXTENSION

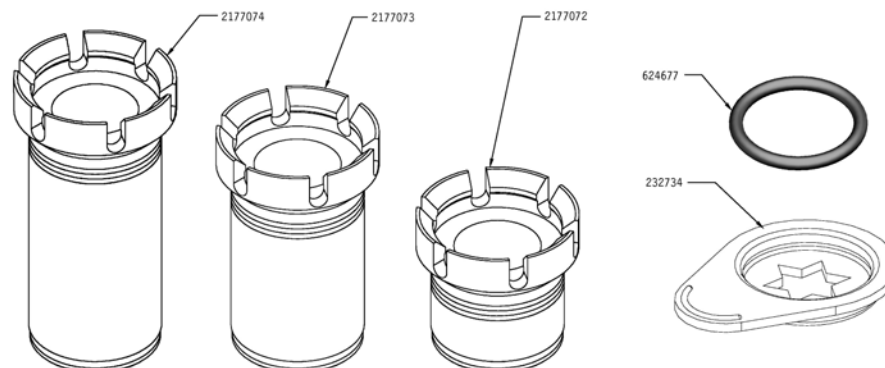

Part	Description	Quantity
232734	Cap - Rosette	4
624677-5	O-Ring - Spigot Extension - Black (5 Pack)	3
2177072	Extension - Spigot - 1.5"	-
2177073	Extension - Spigot - 2.5"	3
2177074	Extension - Spigot - 3.2"	-

6.3 AUGER SHAFT AND FACEPLATE PARTS

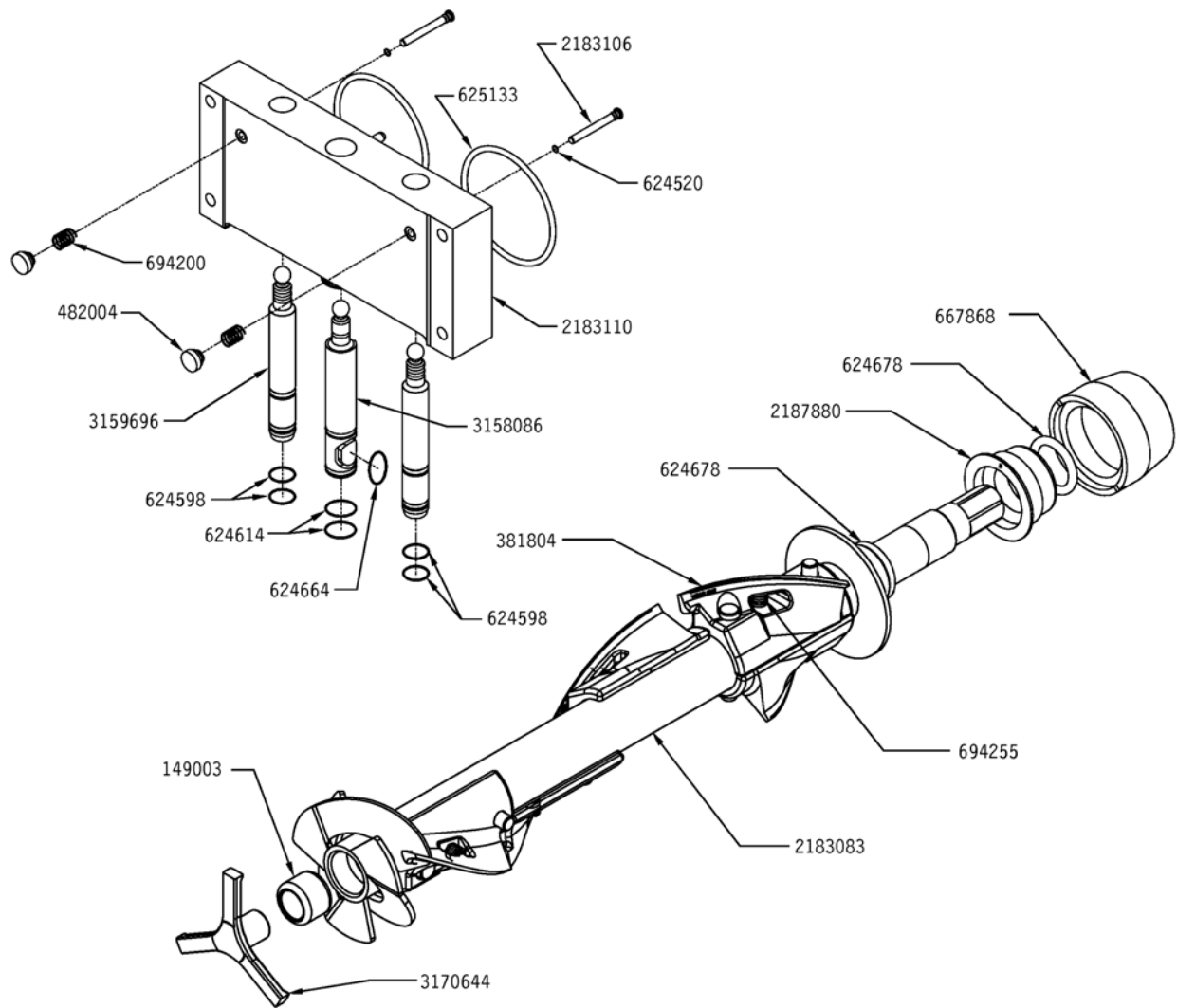

Part	Description	Quantity
149003	Bushing - Front Auger Support	2
381804	Auger Flight	10
482004	Knob - Air Bleed Valve	2
482019	Knob - Front Door	4
624520-5	O-Ring - Air Bleed Valve - Black (5 Pack)	2
624598-5	O-Ring - Outside Spigot - Black (5 Pack)	4
624614-5	O-Ring - Top & Bottom Center Spigot - Black (5 Pack)	2
624664-5	O-Ring - Middle Center Spigot - Black (5 Pack)	1
624678-5	O-Ring - Rear Seal & Rear Seal Adapter - Black (5 Pack)	4
625133	O-Ring - Front Door - Red	2
667868	Seal - Rear Auger (Orange)	2
694200	Spring - Air Bleed Valve	2
694255	Spring - Auger Flight	10
744273	Tray - Drip	1
744276	Tray - Drain	1
2183083	Auger Shaft	2
2183106	Valve - Air Bleed	2
2183110	Door w/Pins & Air Bleed Valve	1
2187880	Adapter - Rear Seal	2
3158086	Spigot Body - Center	1
3159696	Spigot Body - Outer	2
3170644	Support - Front Auger	1

6.4 CAB TUBING ASSEMBLY

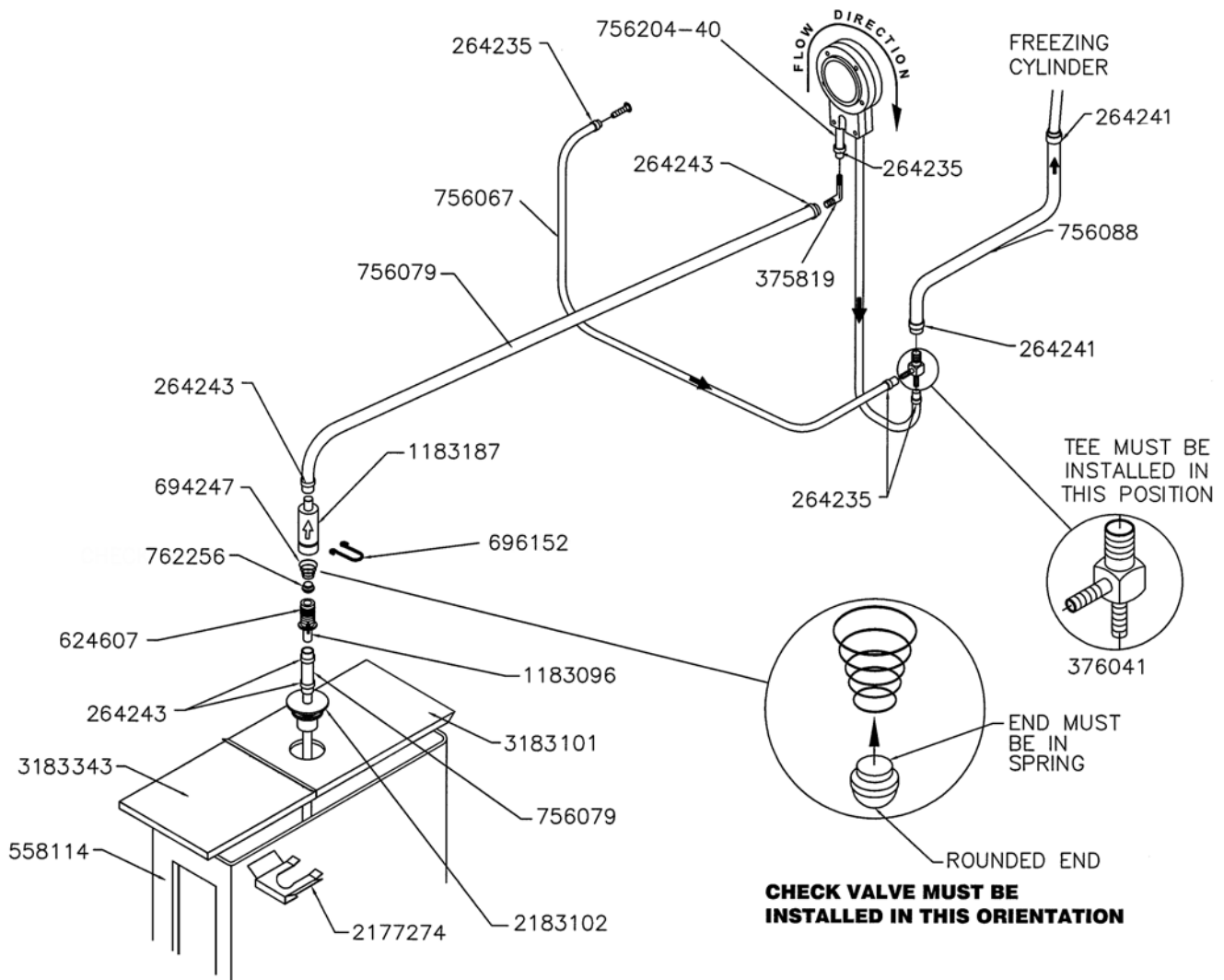

Part Number	Description	Quantity
264235	Clamp - Metal (1/4" ID Tubing)	8
264241	Clamp - Metal (1/2" ID Tubing)	4
264243	Clamp - Metal (3/8" ID Tubing)	8
375819	Elbow - Barbed (3/8" - 1/4")	2
376041	Tee Connector - 3-Way (Stainless)	2
558114	Mix Container Only	2
624607-5	O-Ring - Check Valve Body - Black (5 Pack)	4
694247	Spring - Check Valve	2
696152	Clip - Lock (Check Valve)	2
756067	Tubing - 1/4" ID - Clear - Air Line (25' Increments) (Per Inch)	13"(2)
756079	Tubing - 3/8" ID - Clear - Mix Line (25' Increments) (Per Inch)	24"(2) & 2"(2)
756088	Tubing - 1/2" ID - Clear - Mix Line (25' Increments) (Per Inch)	6"(2)
756204	Tubing - 1/4" ID - Pump (50' Box Only) (Per Inch)	-
756204-40	Tubing - 1/4" ID - Pump (Pre-Cut 40" Piece)	8
762256	Check Valve - Mix Outlet	2
1183096	Check Valve - Mix In Line (Inner)	2
1183187	Check Valve - Mix In Line (Outer)	2
2177274	Clip - Retaining (Mix Probe To Cover)	2
2183102	Pick-Up Tube - Mix	2
3183101	Cover - Rear (Mix Container)	2
3183343	Cover - Front (Mix Container)	2

1. Scope:

Stoelting, A Vollrath Company (“Stoelting”) warrants to the first user (the “Buyer”) that the Stoelting-branded freezer equipment (the “Equipment”) will be free from defects in materials and workmanship under normal use and proper maintenance for the period listed below in the Warranty Period section. All warranty periods begin on the date of original install or one (1) year from the shipping date, whichever occurs first. This warranty is subject to all conditions, exceptions, and limitations contained herein.

2. Disclaimer of Other Warranties:

THIS WARRANTY IS EXCLUSIVE; AND STOELTING HEREBY DISCLAIMS ANY IMPLIED WARRANTY OF MERCHANTABILITY OR FITNESS FOR PARTICULAR PURPOSE.

3. Remedies:

Stoelting’s sole obligations, and Buyer’s sole remedies, for any breach of this warranty shall be, at Stoelting’s option, one of the following: repair or replacement of the affected component at Stoelting’s plant in Kiel, Wisconsin, or refund of the purchase price of the affected Equipment. Stoelting, through an Authorized Stoelting Provider, will deinstall/reinstall the affected component from/into the equipment (“Labor”) for the period listed below in the Warranty Period section. These obligations/remedies are subject to the conditions that Buyer (a) signs and returns to Stoelting, upon installation, the Start-Up and Training Checklist for the affected equipment, (b) gives Stoelting prompt written notice of any claimed breach of warranty within the applicable warranty period, and (c) delivers the affected equipment to Stoelting or its designated service location, in its original packaging/crating, also within that period. Buyer shall bear the cost and risk of shipping to and from Stoelting’s plant or designated service location.

4. Warranty Period:

Equipment	Part	Part Warranty Period	Labor Warranty Period
Soft Serve & Shake	Freezing Cylinders	Five (5) Years	Twelve (12) Months
	Hoppers		
	Compressors		
	Drive Motors		
	Speed Reducers		
	Augers		
Frozen Uncarbonated Beverage	Evaporator	Five (5) Years	Twelve (12) Months
	Compressors		
	Drive Motors		
	Speed Reducers		
Custard & Batch	Freezing Cylinders	Two (2) Years	Twelve (12) Months
	Hoppers		
	Compressors		
	Drive Motors		
	Speed Reducers		
	Beaters Auger Shafts		
Dipping Cabinets & Display Cabinets	All components	Twelve (12) Months	Twelve (12) Months
Frozen Beverage / Granita Dispenser	Compressors	Five (5) Years	Twelve (12) Months
	Electronic Board	Three (3) Years	
	All other components	Two (2) Years	
AutoVend	All components	Twelve (12) Months	Twelve (12) Months
Crème Whippers	Compressors	Two (2) Years	Twelve (12) Months
	Motors		
	Condensers		
All equipment	All other components not specified above	Twelve (12) Months	Twelve (12) Months

5. **Conditions:**

- a) If the date of the original installation cannot be verified, these warranty periods begin one (1) year from the shipping date. It is the responsibility of the seller to disclose this information to the Buyer at the time of sale.
- b) Stoelting shall not be responsible to provide any remedy under this warranty with respect to any component that fails by reason of negligence, abnormal use, misuse or abuse, faulty repair made by others, use with parts or equipment not manufactured or supplied by Stoelting, any modification or alteration of any parts or equipment, or damage in transit.
- c) This warranty is valid only if the Equipment is installed and serviced by an Authorized Stoelting Provider and only if new, genuine Stoelting parts are used.
- d) The Equipment installation location must have suitable conditions as explained in the Stoelting operators manual, specification sheet, and/or technical manual including but not limited to, ambient temperature, water supply parameters, and space requirements.
- e) The Authorized Stoelting Provider must return defective parts, at Stoelting's discretion, for credit.
- f) Any refrigerant other than that specified on the Equipment model identification nameplate voids this warranty.

6. **Exceptions:**

This warranty does **NOT** cover any of the following

- a) Costs associated with installation labor, disposal of equipment being replaced, and shipping costs of replacement parts or Equipment.
- b) Cleaning, maintenance or lubrication of the Equipment as outlined in the Stoelting operators manual.
- c) This warranty does not extend to parts, sometimes called "wear parts", which are generally expected to deteriorate and to require replacement as equipment is used, including but limited to o-rings, auger flights, auger seals, auger support bushings, and drive belts. All such parts are sold **AS IS**.
- d) External components including but not limited to hoses, piping, or electrical equipment.
- e) Labor and travel charges due to return trips or waiting if the Authorized Stoelting Provider is prevented from promptly starting service work upon arrival. This exception includes labor charges incurred for limited access facilities including, but not limited to, government and military buildings, and airports.
- f) Failure, damage, or repairs due to faulty installation, misapplication, abuse, lack of service, or improper service, unauthorized alteration, improper operation as indicated in the Stoelting operators manual, including but not limited to failure to properly assemble and/or clean, improper tool usage, or use of unapproved lubrication, or cleaning and sanitizing supplies.
- g) Any costs associated with electricity, including utility increases, from any reason whatsoever.
- h) Damage resulting from the use of refrigerant other than that specified on the Equipment model identification nameplate.
- i) The use of this equipment as a rental asset negates all warranties associated with the equipment.
- j) Any special, indirect or consequential property or commercial damage of any nature whatsoever, if the jurisdiction allows this exclusion.
- k) Costs not covered by the Stoelting Travel Pay policy. Stoelting covers only the first trip travel which is a flat rate by mileage one-way from the service company's home location to the job site. The flat rate is calculated as follows:
 - o 0-50 Miles \$85
 - o 51-110 Miles \$127
 - o 111-160 Miles \$165
 - o Over 160 Miles The maximum reimbursed by Stoelting is \$165

Any travel costs not covered may be invoiced to the customer.

7. **Limitations:**

THE REMEDIES SET FORTH IN THIS WARRANTY SHALL BE THE SOLE LIABILITY STOELTING AND THE EXCLUSIVE REMEDY OF BUYER WITH RESPECT TO EQUIPMENT SUPPLIED BY STOELTING; AND IN NO EVENT SHALL STOELTING BE LIABLE FOR ANY INCIDENTAL OR CONSEQUENTIAL DAMAGES, INCLUDING AS EXAMPLES BUT NOT INTENDED TO BE LIMITED TO DOWNTIME, OVERHEAD, MATERIALS, PERFORMANCE PENALTIES, LOST SALES, LOST PROFITS, PRODUCT LOSS, OR PROPERTY DAMAGES, WHETHER FOR BREACH OF WARRANTY OR OTHER CONTRACT BREACH, NEGLIGENCE OR OTHER TORT, OR ON ANY STRICT LIABILITY THEORY.