



Model O231
SERVICE MANUAL

Manual No. [513646](#)

Sept. 2010

This manual provides basic information about the machine. Instructions and suggestions are given covering its operation and care.

The illustrations and specifications are not binding in detail. We reserve the right to make changes to the machine without notice, and without incurring any obligation to modify or provide new parts for machines built prior to date of change.

DO NOT ATTEMPT to operate the machine until instructions and safety precautions in this manual are read completely and are thoroughly understood. If problems develop or questions arise in connection with installation, operation, or servicing of the machine, contact Stoelting.



stoeltingfoodservice.com

Stoelting Foodservice Equipment
502 Highway 67
Kiel, WI 53042-1600
U.S.A.

Main Tel: 800.558.5807
Fax: 920.894.7029

Customer Service: 888.429.5920
Fax: 800.545.0662
Email: foodservice@stoelting.com

© 2014 PW Stoelting, LLC

A Few Words About Safety

Safety Information

Read and understand the entire manual before operating or maintaining Stoelting equipment.

This manual provides the operator with information for the safe operation and maintenance of Stoelting equipment. As with any machine, there are hazards associated with their operation. For this reason safety is emphasized throughout the manual. To highlight specific safety information, the following safety definitions are provided to assist the reader.

The purpose of safety symbols is to attract your attention to possible dangers. The safety symbols, and their explanations, deserve your careful attention and understanding. The safety warnings do not by themselves eliminate any danger. The instructions or warnings they give are not substitutes for proper accident prevention measures.

If you need to replace a part, use genuine Stoelting parts with the correct part number or an equivalent part. We strongly recommend that you do not use replacement parts of inferior quality.



Safety Alert Symbol:

This symbol Indicates danger, warning or caution. Attention is required in order to avoid serious personal injury. The message that follows the symbol contains important information about safety.

Signal Word:

Signal words are distinctive words used throughout this manual that alert the reader to the existence and relative degree of a hazard.



The signal word “WARNING” indicates a potentially hazardous situation, which, if not avoided, may result in death or serious injury and equipment/property damage.



The signal word “CAUTION” indicates a potentially hazardous situation, which, if not avoided, may result in minor or moderate injury and equipment/property damage.

CAUTION

The signal word “CAUTION” not preceded by the safety alert symbol indicates a potentially hazardous situation, which, if not avoided, may result in equipment/property damage.

NOTE (or NOTICE)

The signal word “NOTICE” indicates information or procedures that relate directly or indirectly to the safety of personnel or equipment/property.

TABLE OF CONTENTS

Section	Description	Page
1	Introduction	
1.1	Description	1
1.2	Specifications	1
2	Installation Instructions	
2.1	Safety Precautions	5
2.2	Shipment and Transit	5
2.3	Machine Installation	5
2.4	Installing Permanent Wiring	5
3	Initial Set-Up and Operation	
3.1	Operator's Safety Precautions	7
3.2	Operating Controls and Indicators	7
3.3	Important Information Regarding Cleaning and Sanitizing	8
3.4	Disassembly of Machine Parts	10
3.5	Cleaning Disassembled Parts	10
3.6	Sanitizing Machine Parts	11
3.7	Cleaning the Machine	11
3.8	Assembling Machine	11
3.9	Sanitizing	12
3.10	Freeze Down and Operation	12
3.11	Mix Information	13
4	Maintenance and Adjustments	
4.1	Accessing Control Readings and Settings	15
4.2	Navigation and Modifying Settings	15
4.3	User Interface Screens	15
4.4	Performance Screens	16
4.5	Settings Screens	16
4.6	Utilities Screens	18
4.7	Errors & Statistics Screens	20
4.8	Updating Firmware	22
4.9	Drive Belt Tension Adjustment	22
4.10	Condenser Cleaning	23
4.11	Preventative Maintenance	23
4.12	Extended Storage	23

Section	Description	Page
5	Refrigeration System	
5.1	Refrigeration System	25
5.2	Refrigerant Recovery and Evacuation	25
5.3	Refrigerant Charging	26
5.4	Compressor	27
5.5	Condenser	28
5.6	Valves	28
A.	Thermostatic Expansion Valve (TXV)	28
B.	Automatic Expansion Valve (AXV)	29
C.	Check Valve	30
D.	High Pressure Cutout	30
E.	Evaporator Pressure Regulator (EPR)	31
F.	Water Valve (Water Cooled Models Only)	32
5.7	Solenoid	32
5.8	Filter Drier	34
6	Electrical and Mechanical Control Systems	
6.1	Intellitec2 Control	35
6.2	Contactors	35
6.3	Drive Motor	36
6.4	Capacitors	37
6.5	Gearbox	37
6.6	Condenser Fan Motor (Air-Cooled Only)	38
6.7	Spigot Switch	38
6.8	Temperature Control Sensor	40
7	Troubleshooting	
7.1	Error Codes	41
7.2	Troubleshooting	41
7.3	Troubleshooting - Machine	44
8	Replacement Parts	
8.1	Decals and Lubrication	45
8.2	Auger Shaft and Faceplate Parts	46
8.3	Spigot Assembly	48
8.4	Panels and Screws	48
8.5	Electrical Panels	49
8.6	Internal Components	50
8.7	Wiring Diagrams	52

SECTION 1 INTRODUCTION

1.1 DESCRIPTION

The Stoelting O231 floor machine is gravity fed. The machine is equipped with the IntelliTec2 control which provides a uniform product. The O231 is designed to operate with almost any type of commercial soft serve or non-dairy mixes available, including: ice milk, ice cream, yogurt, and frozen dietary desserts.

This manual is designed to assist qualified service personnel and operators in the installation, operation and maintenance of the Stoelting O231 gravity machine.



Figure 1-1 Model O231

1.2 SPECIFICATIONS

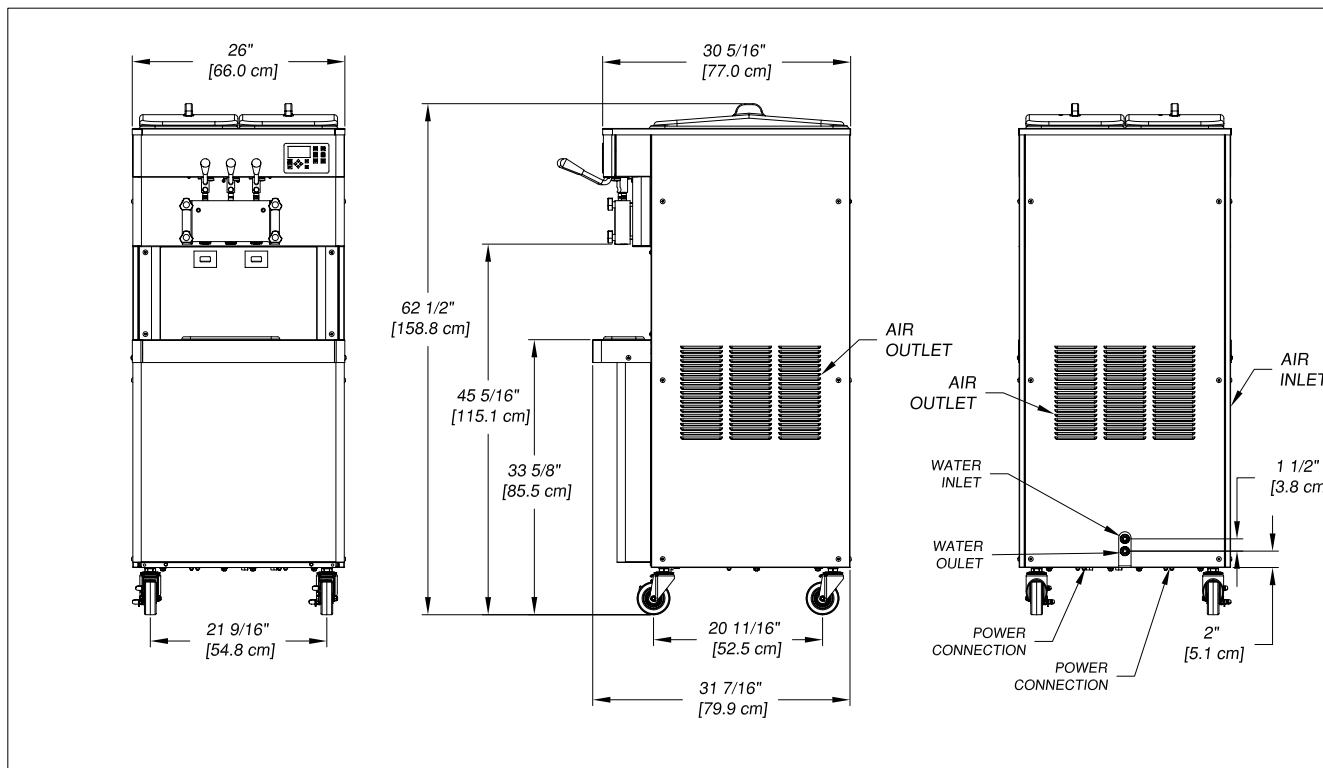

Figure 1-2 Specifications

1.2 SPECIFICATIONS

	O231 Water Cooled		O231 Air Cooled	
Dimensions width height depth	Machine	with crate	Machine	with crate
	26" (66,0 cm)	40-1/4" (102,2 cm)	26" (66,0 cm)	40-1/4" (102,2 cm)
	62-1/2" (158,8 cm)	64-1/2" (163,8 cm)	62-1/2" (158,8 cm)	64-1/2" (163,8 cm)
	31-1/2" (80,0 cm)	33-1/4" (84,5 cm)	31-1/2" (80,0 cm)	33-1/4" (84,5 cm)
Weight	640 lbs (290,2 kg)	730 lbs (331,1 kg)	640 lbs (290,2 kg)	730 lbs (331,1 kg)
Electrical circuit ampacity (per barrel) overcurrent protection device (per barrel)	1 PH	3 PH	1 PH	3 PH
	26A minimum 40A maximum	19A minimum 30A maximum	27A minimum 40A maximum	20A minimum 30A maximum
Compressor	Freezing Cylinders - Two 14,000 Btu/hr (R-404A) Storage - 1,300 Btu/hr Compressor (R-134a)			
Drive Motor	Two - 2 hp			
Cooling	Water cooled units require 3/8" N.P.T. water and drain fittings with 2 inlets and 2 outlets or 1/2" N.P.T. water and drain fittings with 1 inlet and 1 outlet. Maximum water pressure of 130 psi. Minimum water flow rate of 3 GPM. Ideal EWT of 50°-70°F		Air cooled units require 3" (7,6 cm) air space at back and sides.	
Hopper Volume	Two - 6.5 gallon (24,7 liters)			
Freezing Cylinder Volume	Two - 1 gallon (4 quart), 3,79 liters			

Menu	Display	O231
Basic	Consistency Cutout	*
	Cut In Temp	19.5 °F
	Cycles until sleep	20 count
	Stir On	15 seconds
	Stir Off	300 seconds
Advanced	StdbY On time	10 seconds
	StdbY Off time	360 seconds
	StdbY Time	120 minutes
	Sleep1 drv On	15 seconds
	Sleep1 drv Off	300 seconds
	Sleep2 Cutin Temp	38 °F
	Sleep2 Cutout Temp	30 °F
	Default Off Time	600 seconds
	Pressure Sensing	SWITCH
	Liquid Sensing	RESIS
Storage	Storage Cut In	37 °F
	Storage Cut Out	31 °F
	Storage Offset	2
	Storage Off	2 minutes
	Storage On	200 seconds
	Storage Max On	10 minutes
	Storage Recovery	1 minutes
	Storage Too Warm Temp	50 °F
Storage Too Warm Time	2hours	

	O231
Refrigerant	R-404A
Charge	(W/C) 26 oz (A/C) 35 oz
Suction Pressure	21 psig
Discharge Pressure	240 psig
EPR Valve	25-26 psig (R-134A Hopper Condenser)

* Consistency Cutout needs to be adjusted to product requirements.

IntelliTec2 Control Modes of Operation

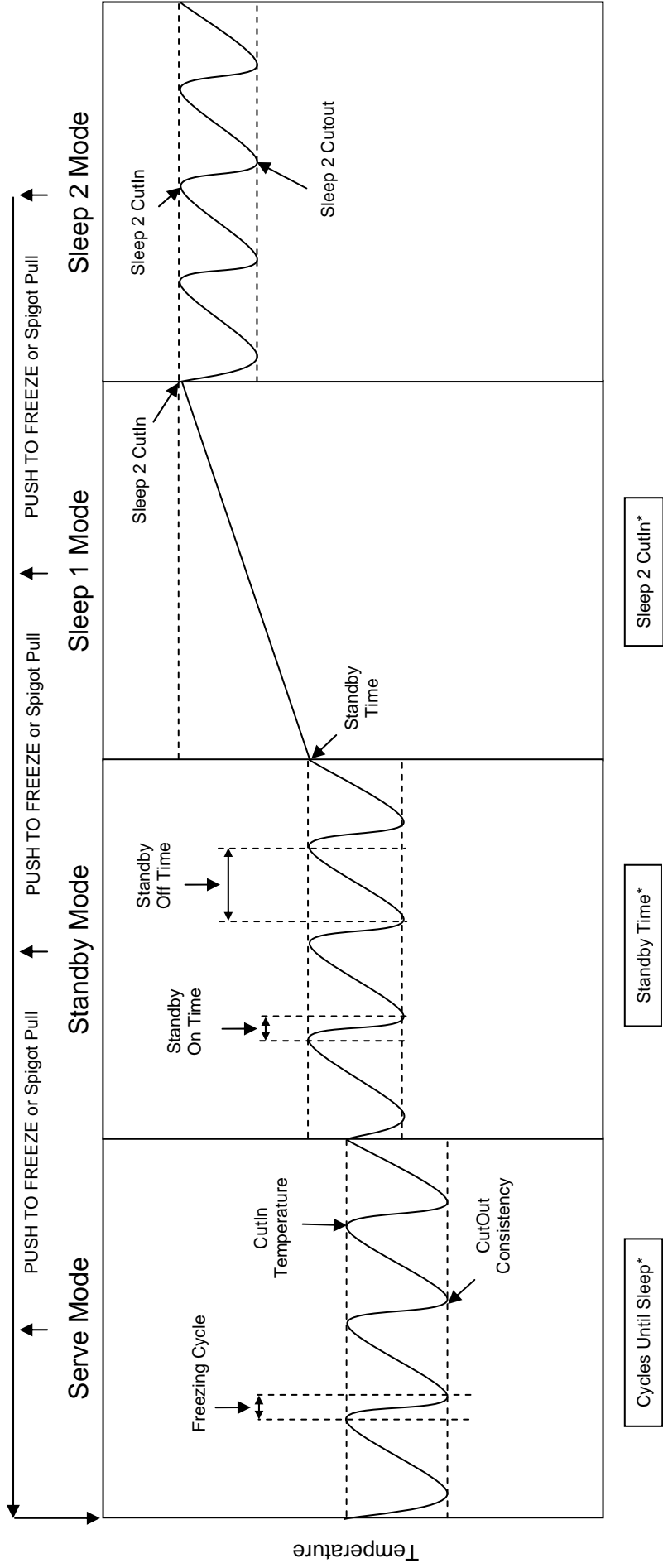

* Resets any time the PUSH TO FREEZE button is pressed or a spigot is pulled. In order for the mode to change, it has to go through its normal cycles without reset.

Note:

- 1) A stir cycle will start in each mode. The cycle is independent of the freezing cycle.
- 2) Normal start up mode is Sleep 1 when the number of cycles is set below 99. When cycles are set higher than 99, the freezer will start up in the Serve mode.
- 3) Sensor failure will keep the control in Serve and Standby modes only.
- 4) A freeze cycle will reset the stir cycle.

SECTION 2 INSTALLATION INSTRUCTIONS

2.1 SAFETY PRECAUTIONS

Do not attempt to operate the machine until the safety precautions and operating instructions in this manual are read completely and are thoroughly understood.

Take notice of all warning labels on the machine. The labels have been put there to help maintain a safe working environment. The labels have been designed to withstand washing and cleaning. All labels must remain legible for the life of the machine. Labels should be checked periodically to be sure they can be recognized as warning labels.

If danger, warning or caution labels are needed, indicate the part number, type of label, location of label, and quantity required along with your address and mail to:

STOELTING
ATTENTION: Customer Service
502 Hwy. 67
Kiel, Wisconsin 53042

2.2 SHIPMENT AND TRANSIT

The machine has been assembled, operated and inspected at the factory. Upon arrival at the final destination, the entire machine must be checked for any damage which may have occurred during transit.

With the method of packaging used, the machine should arrive in excellent condition. **THE CARRIER IS RESPONSIBLE FOR ALL DAMAGE IN TRANSIT, WHETHER VISIBLE OR CONCEALED.** Do not pay the freight bill until the machine has been checked for damage. Have the carrier note any visible damage on the freight bill. If concealed damage and/or shortage is found later, advise the carrier within 10 days and request inspection. The customer must place claim for damages and/or shortages in shipment with the carrier. Stoelting, Inc. cannot make any claims against the carrier.

2.3 MACHINE INSTALLATION



WARNING

Installation must be completed by a qualified electrician/refrigeration specialist.

Incorrect installation may cause personal injury, severe damage to the machine and will void factory warranty.

Installation of the machine involves moving the machine close to its permanent location, removing all crating, setting in place, assembling parts, and cleaning.

- A. Uncrate the machine.
- B. Install the four casters. Turn the threaded end into the machine until no threads are showing. To level, turn out casters no more than 1/4" maximum, then tighten all jam nuts.
- C. The machine must be placed in a solid level position.

NOTE

Accurate leveling is necessary for correct drainage of freezing cylinder and to insure correct overrun.

- D. Machines with air cooled condensers require a minimum of 3" (7,5cm) of space on all sides and 10" (25cm) at the top for proper circulation. (Fig. 2-1)



Figure 2-1 Space and Ventilation Requirements

- E. Machines that have a water cooled condenser require 1/2" NPT supply and drain fittings.

2.4 INSTALLING PERMANENT WIRING

To install wiring follow the steps below:

- A. Refer to the nameplate on the side panel of the machine for specific electrical requirements. Make sure the power source in the building matches the nameplate requirements.
- B. Remove the back panel and the junction box cover located at the bottom of the machine.
- C. Install permanent wiring according to local code.

SECTION 3 INITIAL SET-UP AND OPERATION

3.1 OPERATOR'S SAFETY PRECAUTIONS

SAFE OPERATION IS NO ACCIDENT; observe these rules:

- A. Know the machine. Read and understand the Operating Instructions.
- B. Notice all warning labels on the machine.
- C. Wear proper clothing. Avoid loose fitting garments, and remove watches, rings or jewelry that could cause a serious accident.
- D. Maintain a clean work area. Avoid accidents by cleaning up the area and keeping it clean.
- E. Stay alert at all times. Know which switch, push button or control you are about to use and what effect it is going to have.
- F. Disconnect power for maintenance. Never attempt to repair or perform maintenance on the machine until the main electrical power has been disconnected.
- G. Do not operate under unsafe operating conditions. Never operate the machine if unusual or excessive noise or vibration occurs.

3.2 OPERATING CONTROLS AND INDICATORS

Before operating the machine, it is required that the operator know the function of each operating control. Refer to Figure 3-1 for the location of the operating controls on the machine. For the information regarding error codes displayed on the control panel, refer to the troubleshooting section of this manual.

WARNING

High voltage will shock, burn or cause death. The OFF-ON switch must be placed in the OFF position prior to disassembling for cleaning or servicing. Do not operate machine with panels removed.

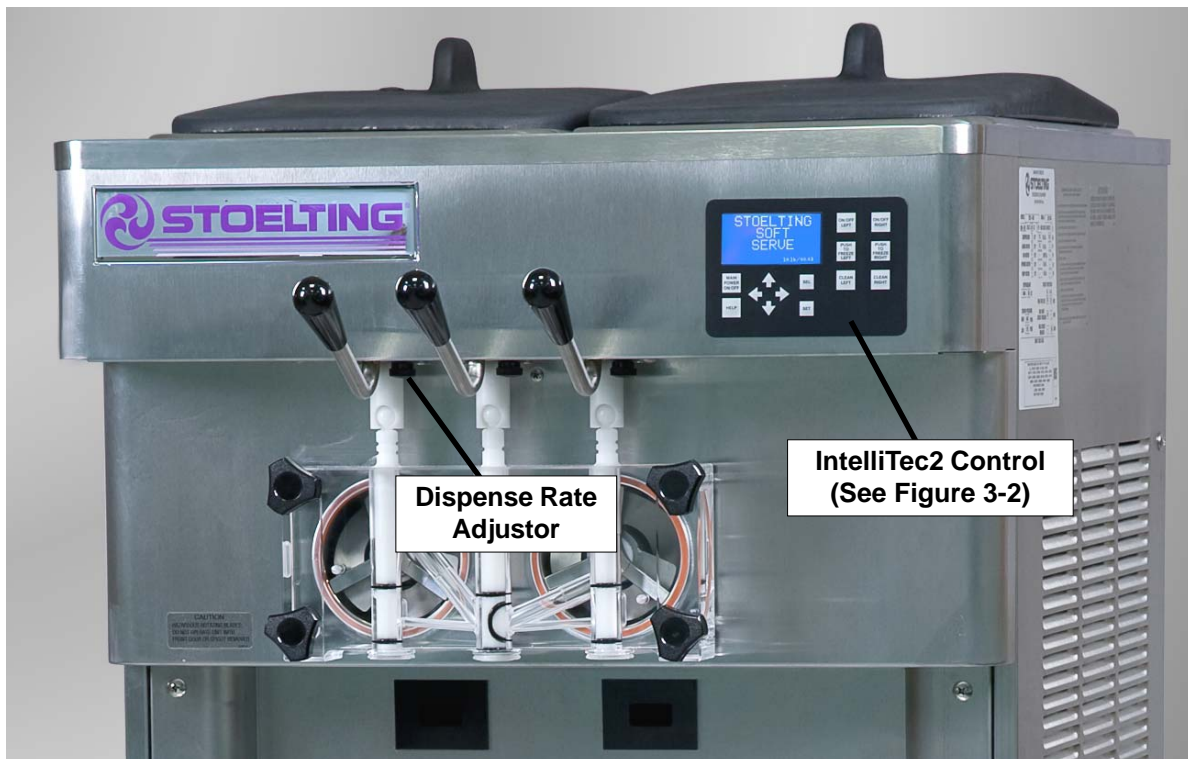

Figure 3-1 Machine Controls

A. INTELLITEC2 TOUCHPAD

Main Power On/Off

The Main Power button is used to supply power to the IntelliTec2 control, the freezing cylinder circuits and the storage refrigeration system. When the machine is first plugged in, the control defaults to the On status with power to the hopper only. If the Main Power On/Off button is pressed for 3 seconds when the machine is on, the machine will turn off and a status message will be displayed on the screen.

Help

Pressing the Help button will display help information dependant on the cursor's location. Pressing the Help button again will exit the help screen.

Selection Button (SEL)

The SEL button is used to select menu options. For details of the menu options, refer to Section 4.

Set Button (SET)

The SET button is used to save changes when modifying control settings. Refer to Section 4 for details.

On/Off Button

Power to the freezing cylinders can then be controlled with the On/Off Left and On/Off Right switches. The On/Off button must be pressed for 3 seconds to turn the power off. This prevents accidentally turning power off.

Push to Freeze Button

Pressing the PUSH TO FREEZE button initiates "Serve Mode".

Clean Button

The CLEAN button initiates "Clean Mode".

Arrow Buttons (←, ↑, →, ↓)

The arrow buttons are used to navigate through the control readings and settings. Section 2 contains details on all the readings and settings.

B. SPIGOT SWITCH

The spigot switch is mounted to the spigot cam assembly behind the header panel. When the spigot is opened to dispense product, the spigot switch opens and the "Serve Mode" begins.

C. DISPENSE RATE ADJUSTOR

The dispense rate adjustor is located under the header panel, to the immediate right of the spigot handles. Turning the knob counterclockwise will decrease the dispense rate.

3.3 IMPORTANT INFORMATION REGARDING CLEANING AND SANITIZING

Soft serve machines require special consideration when it comes to food safety and proper cleaning and sanitizing.

The following information specifically covers issues for cleaning and sanitizing frozen dessert machines. This information is meant to supplement a comprehensive food safety program.

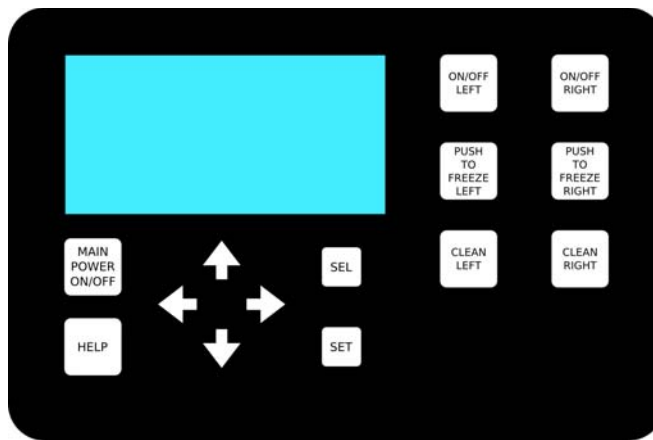

Figure 3-2 IntelliTec2 Control

SOIL MATERIALS ASSOCIATED WITH FROZEN DESSERT MACHINES

MILKFAT/BUTTERFAT – As components of ice-cream/frozen custard mix, these soils will accumulate on the interior surfaces of the machine and its parts. Fats are difficult to remove and help attribute to milkstone buildup.

MILKSTONE – Is a white/gray film that forms on equipment and utensils that are exposed to dairy products. These films will accumulate slowly on surfaces because of ineffective cleaning, use of hard water, or both. Milkstone is usually a porous deposit, which will harbor microbial contaminants and eventually defy sanitizing efforts.

Once milkstone has formed, it is very difficult to remove. Without using the correct product and procedure, it is nearly impossible to remove a thick layer of milkstone.

(NOTE: general-purpose cleaners DO NOT remove milkstone.) This can lead to high bacteria counts and a food safety dilemma.

IT IS BEST TO CONTROL MILKSTONE ON A DAILY BASIS BEFORE IT CAN BECOME A SIGNIFICANT FOOD SAFETY PROBLEM.

In addition to food safety, milkstone can cause premature wear to machine parts, which can add to costs for replacement parts or possibly more expensive repairs if worn machine parts are not replaced once they have become excessively worn.

IMPORTANT DIFFERENCES BETWEEN CLEANING AND SANITIZING

CLEANING vs. SANITIZING

It is important to distinguish between cleaning and sanitizing. Although these terms may sound synonymous, they are not. BOTH are required for adequate food safety and proper machine maintenance.

CLEANING

- Is the removal of soil materials from a surface.
- Is a prerequisite for effective sanitizing.

NOTE

An UNCLEAN surface will harbor bacteria that can defy sanitizing efforts.

Bacteria can develop and resist sanitizing efforts within a layer of soil material (milkstone). Thorough cleaning procedures that involve milkstone removal are critical for operators of frozen dessert machines.

SANITIZING

- Kills bacteria.
- Can be effective on clean surfaces only.

NOTE

Using a SANITIZER on an unclean surface will not guarantee a clean and safe frozen dessert machine.

PROPER DAILY MAINTENANCE:

The Only Way to Assure Food Safety and Product Quality

Proper daily maintenance can involve a wide variety of products and procedures. Overall, the products and procedures fall into three separate categories. (Please note that this is a brief overview intended for informational purposes only.)

1. **CLEANING** – This involves draining mix from the freezing cylinder and rinsing the machine with water. Next, a cleaner is run through the machine. Then, the machine is disassembled and removable parts are taken to the sink for cleaning.
2. **MILKSTONE REMOVAL** – Since most cleaners do not have the ability to remove milkstone, the use of a delimer becomes necessary. Although this procedure may not be needed on a daily basis, it will usually follow the cleaning procedure. It requires letting a delimer solution soak in the machine for an extended period. Individual parts are also soaked in a deliming solution for an extended period of time (more about delimers in Additional Information).
3. **SANITIZING** – After the machine has been cleaned and contains no milkstone, the machine is reassembled. Then a FDA-approved sanitizing solution is run through the machine to kill bacteria. The machine is then ready for food preparation.

As a recommended cleaner and sanitizer for your frozen dessert machine, STERA-SHEEN has proven to be one of the best daily maintenance products for:

- **CLEANING** – Thorough removal of all solids including butterfat and milk fat.
- **MILKSTONE REMOVAL** – Complete removal of milkstone.
- **SANITIZING** – FDA-approved no rinse sanitizer for food contact surfaces.

ADDITIONAL INFORMATION

THE USE OF DELIMERS

A delimer is a strong acid that has the ability to dissolve milkstone. This type of chemical may become necessary once high levels of milkstone have developed. While these products are very effective for removing HIGH levels of milkstone, they are not ideal for two reasons:

1. **PRODUCT SAFETY** – Strong acids are dangerous chemicals. Carefully follow safety instructions provided with delimer products.
2. **MACHINE DAMAGE** – Strong acids will attack metal and rubber causing premature wear of parts. The use of a delimer needs to be closely monitored to avoid damage to machine surfaces and parts.

With proper daily use of STERA-SHEEN or its equivalent, there is no need for the use of a DELIMER.

DO NOT USE BLEACH

- **BLEACH HAS ABSOLUTELY NO CLEANING PROPERTIES.**
- **BLEACH IS CORROSIVE.** It will damage components of the machine causing premature wear and metal corrosion.

GENERAL PURPOSE CLEANERS

General purpose cleaners do not have the ability to remove milkstone. Milkstone will become a problem if not remedied with additional products and procedures.

THE USE OF CHLORINE TEST STRIPS

“Test strips” are used to determine concentrations of active chlorine in sanitizing solutions. To use the strips, tear off a small portion and submerge it into the sanitizing solution. Then, compare the color change to the color key on the side of the test strip dispenser to determine the approximate chlorine concentration.

The ideal concentration of chlorine needs to be 100 ppm (as stated by the FDA).

NOTE

Follow the directions on the container for proper concentration.

Two main factors contribute to falling chlorine concentrations in a sanitizing solution.

1. **PRODUCT USE** – As the chlorine in the solution is being used, chlorine concentrations fall.
2. **TIME** – As time passes, small amounts of chlorine “evaporate” from the solution. (That is why you can smell it.)

Sanitizing solutions should not be allowed to fall below 100 ppm chlorine. New solutions should be mixed once old solutions become ineffective.

3.4 DISASSEMBLY OF MACHINE PARTS

Before using the machine for the first time, complete machine disassembly, cleaning and sanitizing procedures need to be followed. Routine cleaning intervals and procedures must comply with the local and state health codes. Inspection for worn or broken parts should be made at every disassembly of the machine. All worn or broken parts should be replaced to ensure safety to both the operator and the customer and to maintain good machine performance and a quality product. Check the wear line on the auger flights on a regular basis (Fig. 3-3) and replace as needed. Frequency of cleaning must comply with the local health regulations.



Figure 3-3 Auger Flight Wear

To disassemble the machine, refer to the following steps:

A. DISASSEMBLY OF FRONT DOOR

1. Turn the machine off by pressing the Main Freezer Power Off/On button on the IntelliTec2 control.
2. Remove the knobs on the front door.
3. Remove the front door by pulling it off the studs.
4. Remove the spigot through the bottom of the front door.
5. Remove all o-rings from parts by first wiping off the lubrication using a clean towel. Then squeeze the o-ring upward to form a loop (Fig. 3-4). Roll the o-ring out of the groove.



Figure 3-4 Removing O-Ring

B. DISASSEMBLY OF AUGER

1. Remove the front auger support and bushing.
2. Remove the auger assembly from the machine. Pull the auger out of the machine barrel slowly. As the auger is being pulled out, carefully remove each of the plastic flights with springs.
3. Keep the rear of the auger tipped up once it is clear of the freezing cylinder to prevent the rear seal assembly from dropping.
4. Wipe the spline lubricant off of the hex end of the auger with a paper towel. Remove the rear seal assembly (Fig. 3-5).
5. Unscrew the springs from the auger flights.



Figure 3-5 Rear Seal Assembly

3.5 CLEANING DISASSEMBLED PARTS

Disassembled machine parts require complete cleaning, sanitizing and air drying before assembling. Local and state health codes will dictate the procedure required. Some state health codes require a four sink process (pre-wash, wash, rinse, sanitize, air dry), while others require a three sink process (without the pre-wash step). The following procedures are a general guideline only. Consult your local and state health codes for the procedures required in your location.

- A. Prepare detergent water by mixing 2 oz. of Palmolive detergent or equivalent in 2 gallons of 90° to 110°F (32° to 43°C) water. Place all parts in the detergent solution and clean with provided brushes.
- B. Rinse all parts with clean 90° to 110°F (32° to 43°C) water.
- C. Wash the hopper and freezing cylinder with the 90° to 110°F (32° to 43°C) detergent water and brushes provided (Refer to Figure 3-6).
- D. Clean the rear seal surfaces from the inside of the freezing cylinder with the 90° to 110°F (32° to 43°C) detergent water.

3.6 SANITIZING MACHINE PARTS

- A. Use Stera-Sheen or equivalent sanitizing solution mixed according to manufacturer's instructions to provide a 100 parts per million strength solution. Mix sanitizer in quantities of no less than 2 gallons of 90° to 110°F (32°C to 43°C) water. Any sanitizer must be used only in accordance with the manufacturer's instructions.
- B. Place all parts in the sanitizing solution for 5 minutes, then remove and let air dry completely before assembling in machine.

3.7 CLEANING THE MACHINE

The exterior should be kept clean at all times to preserve the luster of the stainless steel. A high grade of stainless steel has been used on the machine to ease cleanup. To remove spilled or dried mix, wash the exterior with 90° to 110°F (32°C to 43°C) detergent water and wipe dry.

Do not use highly abrasive materials, as they will mar the finish. A mild alkaline cleaner is recommended. Use a soft cloth or sponge to apply the cleaner. For best results, wipe with the grain of the steel.

- A. Clean the rear seal surface from inside of the freezing cylinder.
- B. Using sanitizing solution and the large barrel brush provided, sanitize the freezing cylinder by dipping the brush in the sanitizing solution and brushing the inside of the freezing cylinder.
- C. Remove the drip tray by pulling from the front panel. Clean and replace the drip tray.

3.8 ASSEMBLING MACHINE

To assemble the machine parts, refer to the following steps:

NOTICE

Petrol-Gel sanitary lubricant or equivalent must be used when lubrication of machine parts is specified.

NOTICE

The United States Department of Agriculture and the Food and Drug Administration require that lubricants used on food processing equipment be certified for this use. Use lubricants only in accordance with the manufacturer's instructions.

- A. Assemble all o-rings onto parts dry, without lubrication. Then apply a thin film of sanitary lubricant to exposed surfaces of the o-rings.
- B. Lubricate the rear seal area on the auger shaft with a thin layer of sanitary lubricant. Install the rear seal o-ring. Lubricate the outside of the rear seal o-ring with sanitary lubricant.
- C. Lubricate the inside metal surface of the rear seal and install it onto the auger shaft. **DO NOT** lubricate the outside of the rear auger seal (Fig. 3-6).



Figure 3-6 Lubricate Rear Seal

- D. Lubricate the hex drive end of the auger with a small amount of spline lubricant. A small container of spline lubricant is shipped with the machine.
- E. Screw the springs onto the studs in the plastic flights. The springs must be screwed into the flights completely to provide proper compression.
- F. Install the two plastic flights onto the rear of the auger and insert it part way into the freezing cylinder.
- G. Install the remaining plastic flights, push the auger into the freezing cylinder and rotate slowly until the auger engages the drive shaft.
- H. Apply a thin layer of sanitary lubricant to the inside and outside of the auger support bushing. Install the bushing onto the auger support and install the auger support into the front of the auger. Rotate the auger support so that one leg of the support points straight up.
- I. Apply a thin layer of sanitary lubricant to the o-rings on the spigot body and install the spigot body through the bottom of the front door.
- K. Apply a thin film of sanitary lubricant to the door seal o-ring and fit it into the groove on the rear of the front door.
- M. Place the front door assembly on the mounting studs and the push front door against the machine carefully.
- N. Secure the front door to the machine by placing the knobs on the studs and tightening until finger tight. Do not overtighten. A proper o-ring seal can be observed through the transparent front door.

3.9 SANITIZING

Sanitizing must be done after the machine is clean and just before the machine is filled with mix. Sanitizing the night before is not effective. However, you should always clean the machine and parts after using it.

NOTE

The United States Department of Agriculture and the Food and Drug Administration require that all cleaning and sanitizing solutions used with food processing equipment be certified for this use.

When sanitizing the machine, refer to local sanitary regulations for applicable codes and recommended sanitizing products and procedures. The frequency of sanitizing must comply with local health regulations. Mix sanitizer according to manufacturer's instructions to provide a 100 parts per million strength solution. Mix sanitizer in quantities of no less than 2 gallons of 90°F to 110°F (32°C to 43°C) water. Allow sanitizer to contact the surfaces to be sanitized for 5 minutes. Any sanitizer must be used only in accordance with the manufacturer's instructions.

- A. Prepare 2 gallons of sanitizing solution following the manufacturer's instructions.
- B. Install the mix inlet regulator into the hopper.
- C. Pour the sanitizing solution into the hopper.
- D. Make sure the display shows the freezing cylinder is off. If it is not, press the On/Off Left or On/Off Right button to turn it off.

NOTE

If the freezing cylinder is not off, the control will not go into Clean mode. This is to protect from accidentally going into Clean mode.

- E. Press the CLEAN button.
- F. Check for leaks.
 - 1. Check for leaks at the front door seals.
 - 2. Check the drain tray located under the front door for leaks coming from the rear of the rear auger seal.
- G. Using a sanitized soft bristle brush (or equivalent) dipped in sanitizing solution, clean the hopper sides, mix inlet regulator and underside of the hopper cover.
- H. After five minutes, open the spigot to expel sanitizing solution. Drain all of the solution from the machine.
- I. When the solution has drained, press the CLEAN button to stop the auger. Allow the freezing cylinder to drain completely.

The machine is now sanitized and ready for adding mix.

3.10 FREEZE DOWN AND OPERATION

- A. Sanitize immediately before use.
- B. Make sure the display shows the freezing cylinder is off. If it is not, press the On/Off Left or On/Off Right button to turn it off.
- C. Fill the hopper with at least 2.5 gallons of mix.
- D. Place a container under the spigot and open the spigot to allow the mix to flush out about 8 ounces (0.23 liters) of sanitizing solution and liquid mix.
- E. Press the On/Off button for the cylinder.
- F. Press the PUSH TO FREEZE button.

NOTE

After the drive motor starts, there is a 3-second delay before the compressor starts.

- G. When the product is ready, the display will read "SERVE". Open the spigot to dispense product.

NOTE

If the product consistency needs to be adjusted, use the Technician passcode and go to the Basic Settings menu. Adjust the CutOut Consistency higher to increase the consistency or lower to decrease the consistency. Make adjustments in increments of 5 for best results.

- H. The machine dispenses product at a reasonable draw rate. If the machine is overdrawn, the result is a soft product or a product that will not dispense at all. If this occurs, allow the machine to run for approximately 30 seconds before dispensing more product. A dispense rate adjustor is located under the header panel, to the immediate right of the spigot handle. Turning the knob counterclockwise will decrease the dispense rate.
- I. Do not operate the machine when the MIX LOW message is displayed. Refill the mix container immediately.

NOTE

The machine has a standby and sleep mode. After a preset number of freezing cycles, it will enter the standby mode (followed by sleep mode) and remain there until someone draws product or presses the PUSH TO FREEZE button. In the sleep mode, the machine will keep the product below 41°F (5°C). Sleep modes do not take the place of cleaning and sanitizing. Federal, State, and local regulatory agencies determine frequency of cleaning and sanitizing.

3.11 MIX INFORMATION

Mix can vary considerably from one manufacturer to another. Differences in the amount of butterfat content and quantity and quality of other ingredients have a direct bearing on the finished frozen product. A change in machine performance that cannot be explained by a technical problem may be related to the mix.

Proper product serving temperature varies from one manufacturer's mix to another. Mixes should provide a satisfactory product in the 20°F to 24°F range. Diet and low-carb mixes typically freeze to proper consistency at higher temperatures.

When checking the temperature, stir the thermometer in the frozen product to get an accurate reading.

Old mix, or mix that has been stored at too high a temperature, can result in a finished product that is unsatisfactory. To retard bacteria growth in dairy based mixes, the best storage temperature range is between 33° to 38°F (0.5° to 3.3° C).

SECTION 4 MAINTENANCE AND ADJUSTMENTS

This section is intended to provide maintenance personnel with a general understanding of the machine adjustments. It is recommended that any adjustments in this section be made by a qualified person.

4.1 ACCESSING CONTROL READINGS AND SETTINGS

The readings and settings on the IntelliTec2 control are accessed by using a keypad sequence. Press the left arrow button from the Current Status screen to access the passcode input screen.

The specific readings and parameters available depend on the keypad sequence entered. The lowest level is Associate and has limited access. The Manager level has access to the Associate level options as well as performance, error and statistics screens. The Technician level has full access to the control including the Associate and Manager level options.

Following are the keypad sequences for the three levels available.

- Associate** Press the right arrow then the SEL button.
- Manager** Press the right arrow, up arrow then the SEL button
- Technician** Press the right arrow, SET, then the SEL button

4.2 NAVIGATION AND MODIFYING SETTINGS

Navigating through the IntelliTec2 screen is done with the arrow keys on the touchpad. After positioning the cursor on a desired menu, press the SEL button to select that option. If the option is a setting, press the SET button to change the value. Use the arrow keys to change the value. Press the SET button to save the changes.

The SEL button changes the cylinder selection on screens that show the cylinder.

Pressing the left arrow button from any menu will go back one screen. Pressing the left arrow button at the Main Menu screen goes to the Current Status screen.

4.3 USER INTERFACE SCREENS

A. Current Status

```
Current Status            01/01/01
                             12:34:56
Left                      Serve
Right                     Sleep 1
Storage Left              On
Storage Right             On
_ Service Contact Information
```

The Current Status screen gives an overview of the machine's operation. It shows the mode of the freezing cylinders and the storage refrigeration. If there is an error, the error text description replaces the status information.

The Service Contact Information screen is accessed from the Current Status screen. Move the cursor to the Service Contact Information option and press the SEL button.

B. Service Contact Information

```
Service Contact Information

Name
    Stoelting
Telephone Number
    920 - 894 - 2293

Version 00.00/00.00
```

The Service Contact Information screen provides the name and telephone number for service. The default is Stoelting Technical Customer Service. The Manager level can change the default by selecting the Modify Contact Information option.

C. Main Menu

```
Main Menu
- Technician Level Access
_ Fine Consistency Adjustment
_ Performance
_ Modify Settings
_ Utilities
_ Errors and Statistics
```

The Main Menu screen provides access to all the readings and settings on the IntelliTec2 control. To access the Main Menu, use one of the keypad sequences from Section 4.1. The example above shows the options available when entering the Technician keypad sequence. The Associate will only see the Fine Consistency Adjustment option. The Manager will see the Associate options as well as the Performance, Modify Settings and Errors and Statistics options.

D. Fine Consistency Adjustment

Fine Consistency Adjustment	
Cylinder	Right
Changing the fine consistency change the firmness of the product.	
New Consistency Limit	99
_ Fine Consistency	000

Product consistency can be adjusted by the Associate level by using the Fine Consistency Adjustment screen. Increasing the Fine Consistency number increases the product consistency (firmer product). The maximum adjustment is ± 10 .

The New Consistency Limit shows the Fine Consistency adjustment added to the Consistency number.

4.4 PERFORMANCE SCREENS

Performance (1 of 2)	
Cylinder	Right
Consistency	000.00
Cylinder Temp	-000.0°F
Motor Amps	00.000A
Input Voltage	000.0V

A. Performance (1 of 2)

The Performance screens display the current status of the machine. These screens are available to the Manager and Technician levels. Press the right arrow to go to the second screen.

Cylinder

The performance information displayed is for the selected cylinder. To change cylinders press the SEL button.

Consistency

This is the current consistency number of the selected cylinder. The consistency number represents how thick or thin the product in the freezing cylinder is. A higher number means the product is thicker. Go to the Modify Operating Settings menu to change the operating setting.

Cylinder Temperature

This is the current suction line temperature of the selected cylinder.

Motor Amps

This is the current motor amps of the selected cylinder.

Input Voltage

This is the current voltage of the selected cylinder and will only show the voltage when the motor is running.

B. Performance (2 of 2)

Performance (2 of 2)	
Cylinder	Right
Ambient Temp	-000.0°F
Storage Temp	-000.0°F
Number of Cycles	000
Error Status	No Error

The Performance screens display the current status of the machine. This screen shows the current ambient temperature, storage temperature and number of cycles since the Push to Freeze button was pressed or the spigot was pulled. Press the left arrow to go to the first screen.

4.5 SETTINGS SCREENS

A. Modify Operating Settings

Modify Operating Settings
_ Basic Settings
_ Advanced Settings
_ Storage Settings
_ User Preferences
_ Time and Date

This menu provides access to view and change the different operating settings on the machine. The Manager level has access to the User Preferences and Time and Date settings. The Technician level has access to the Manager level and to all other settings as shown.

B. Basic Settings

Basic Settings	
Cylinder	Right
_ CutOut Consistency	000
_ CutIn Temp	00.0°F
_ Cycles Until Sleep	000
_ Stir On	0000 sec
_ Stir Off	0000 sec

This menu contains settings for the CutIn and CutOut, cycles in serve mode and auger cycle times. This screen is available to the Technician level.

Cylinder can be changed by pressing the SEL button.

CutOut Consistency is a number that represents how thick or thin the product in the freezing cylinder is. Increasing the setting creates a thicker product. Decreasing the setting makes a thinner product.

CutIn Temperature is the suction line temperature in the cylinder when a freezing cycle will start.

Cycles Until Sleep or Cycles in Serve Mode is the number of freezing cycles before the freezing cylinder goes into Sleep Mode.

Stir On is the amount of time that the auger rotates during the stir cycle. Stir cycles occur in Serve Mode, Standby Mode and Sleep 2 Mode.

Stir Off is the amount of time between stir cycles. Stir cycles occur in Serve Mode, Standby Mode and Sleep 2 Mode.

C. Advanced Settings (1 of 2)

Advanced Settings (1 of 2)	
Cylinder	Right
_ Standby On Time	0000 sec
_ Standby Off Time	0000 sec
_ Standby Time	000 min
_ Sleep 1 Drive On	0000 sec
_ Sleep 1 Drive Off	0000 sec

The Advanced Settings menu contains standby and sleep mode adjustments and is available to the Technician level. Press the right arrow to go to the second screen.

Cylinder can be changed by pressing the SEL button.

The **Standby On Time** setting determines the length of the freezing cycle in Standby Mode.

The **Standby Off Time** setting determines the length between freezing cycles in Standby Mode.

The **Standby Time** setting determines the total amount of time in Standby Mode.

Sleep 1 Drive On is the amount of time that the auger rotates during the stir cycle in Sleep 1 Mode.

Sleep 1 Drive Off is the amount of time between stir cycles in Sleep 1 Mode.

D. Advanced Settings (2 of 2)

Advanced Settings (2 of 2)	
Cylinder	Right
_ Sleep 2 CutIn	-00.0°F
_ Sleep 2 CutOut	-00.0°F
_ Default Off Time	0000 sec

The Advanced Settings menu contains standby and sleep mode adjustments and is available to the Technician level. Press the left arrow to go to the first screen.

Sleep 2 CutIn is the temperature that a freezing cycle starts in Sleep 2 Mode.

Sleep 2 CutOut is the temperature that a freezing cycle stops in Sleep 2 Mode.

Default Off Time is the maximum time between freezing cycles during Serve Mode.

E. Storage Settings (1 of 2)

Storage Settings (1 of 2)	
_ Storage CutIn	-00.0°F
_ Storage CutOut	-00.0°F
_ Storage Offset	00°F
_ Storage Off	00 min
_ Storage On	0000 sec

This Storage Settings menu contains storage refrigeration parameters and is available to the Technician level. Press the right arrow to go to the second screen.

Storage CutIn is the temperature at which the storage refrigeration cycle starts. This is how warm it will get before starting a storage freezing cycle.

Storage CutOut is the temperature at which the storage refrigeration cycle stops. This is how low the temperature will get before ending the storage freezing cycle.

The **Storage Offset** value is added to the storage temperature reading to determine if storage refrigeration starts with a freezing cycle. This setting helps prevent short cycling and saves energy.

The **Storage Off** setting determines the time between storage refrigeration cycles during a sensor failure.

The **Storage On** setting determines the length of a storage refrigeration cycle during a sensor failure.

F. Storage Settings (2 of 2)

```
Storage Settings (2 of 2)
_ Storage Max On           00 min
_ Storage Recovery        0 min
_ Storage Too Warm       00.0°F
_ Storage Too Warm       000 min
_ Clean Alarm Period     0 day
```

This Storage Settings menu contains storage refrigeration parameters and is available to the Technician level. Press the left arrow to go to the first screen.

The **Storage Max On** setting is the maximum time that a storage refrigeration cycle will run.

The **Storage Recovery** setting is the minimum time between storage refrigeration cycles if the Storage Max On time ends the cycle.

The **Storage Too Warm** values are the temperature and amount of time. When the temperature is above the set temperature for the set period, the Storage too Warm message will be displayed.

The **Clean Alarm Period** is the amount of days the machine will operate before requiring a cleaning. If this setting is reached, the machine will a clean message. Press the Clean button to clear the message. The default setting is 10 days and can be set up to 20 days.

The alarm will reset if one of the following parameters are met.

- A. The cylinder is in clean mode for a minimum period.
- B. The suction line temperature has risen to a minimum temperature
- C. The door is removed from the cylinder.

G. User Preferences

```
User Preferences
_ Language           English
_ Temp Units        Fahrenheit(°F)
_ Service Contact Information
_ Touchpad Lockup
```

The User Preferences menu contains language options, temperature units, service contact information and touchpad lockup. The screen is available to the Manager and Technician levels.

The **Language** setting changes the language displayed. English is the only language currently available.

The **Temperature Units** setting changes the units displayed to Fahrenheit or Celsius.

The **Service Contact Information** option changes the service contact details.

The **Touchpad Lockup** option is used to lock and unlock the keypad for self serve locations.

H. Time and Date

```
Time and Date
Time           00:00:00 AM
Date          00/00/00
Daylight Savings Off
Clock Type    12 HR
_ Modify Time and Date
```

The Time and Date menu shows the time and date settings. The Manager and Technician levels can change the time and date by using the Modify Time and Date option.

4.6 UTILITIES SCREENS

```
Utilities
_ Testing and Manual Operation
_ Restore Factory Defaults
_ Adjust LCD Contrast
_ Clear Error Log
_ Clear Statistics
```

The Utilities menu gives access for testing and for manual operations, restoring factory defaults, adjusting the LCD contrast and clearing error logs or statistics.. The Utilities menu is only available to the Technician level.

A. Testing and Manual Operation

```
Testing and Manual Operation
Select below for testing
_ Left Output Control
_ Right Output Control
_ Left / Right Monitoring
```

The Testing and Manual Operation menu provides access for individual components to be energized to assist with troubleshooting. There are also test monitoring screens that provide details of the machine status during testing. Any energized component will deenergize after leaving the Testing and Manual Operations menu.

Selecting Left or Right Output Control goes to a screen that allows motors, solenoids or the compressor to be individually activated. Activate by moving the cursor to the desired component and press the SET button.

Testing and Manual Ops,	Left
_ Drive Motor	Off
_ Fan Motor	Off
_ Liquid Solenoid	Off
_ Compressor	Off
_ Refer Solenoid	Off
_ Aux Solenoid	Off
_ Pump Motor	Off

Selecting Left/Right Monitoring goes to screens that show current statistics of the selected cylinder.

Test Monitoring (1 of 3)	
Cylinder	Right
Motor Voltage	0.0 V
Motor Current	0.000
I/V Phase Angle	0.0°
Frequency	0.0 Hz
Consistency	0.0

Test Monitoring (2 of 3)	
Cylinder	Right
Ambient Temp	+00.0°F
Cylinder Temp	+00.0°F
Hopper Temp	+00.0°F
Pressure Sensor	
Pressure Sw	On

Test Monitoring (3 of 3)	
Cylinder	Right
Cabinet Door	Closed
Spigot	Closed
Door	Closed
Hi Pressure	No
Liquid Level	Low

The Test Monitoring screens can be used for immediate feedback when troubleshooting. For example the spigot switch can be tested by opening the spigot and observing if the status text changes from "Closed" to "Open".

B. Restore Factory Settings

Restore Factory Settings
This will reset all machine settings to the original factory configurations. Are you sure you want to do that?
_ Yes
_ No

The Restore Factory Settings screen will revert all settings to their original values.

C. Adjust LCD Contrast

Adjust LCD Contrast
0123456789
ABCDEFGHIJKLMNPOQRSTUVWXYZ
Press ▲ ▼ to change

The Adjust LCD Contrast screen adjusts the contrast between the background lighting and the text on the screen.

D. Clear Error Log

Clear Error Log
This will clear the error log. Are you sure you want to do that
_ No
_ Yes

The Clear Error Log screen will clear all the errors in memory.

E. Clear Statistics

Clear Statistics Log
This will clear the statistics log. Are you sure you want to do that
_ No
_ Yes

The Clear Statistics screen will clear all the statistics in memory.

F. Export

```
Export

Connect a USB flash drive to
the port on the control board
move the cursor to the export
data option and press SEL

_ Export Data
```

The Export screen allows you to export all the data and statistics stored in the control. Connect a USB flash drive to the display panel module and select the export option.

4.7 ERRORS & STATISTICS SCREENS

The Errors & Statistics menu gives the Technician access to machine statistics and error history.

A. Machine Statistics (1 of 10)

```
Machine Statistics (1 of 10)
Cylinder                               Right
Time in Serve Mode                     0000 hr
    Last 24hrs                          0000 min
    Last 7days                          0000 hr
Time in Off Mode                         0000 hr
    Last 24hrs                          0000 min
    Last 7days                          0000 hr
```

The Machine Statistics screen 1 of 10 shows the time in serve mode and time in sleep mode. The screen shows a running total, the total for the previous day and the total for the previous week for both statistics.

B. Machine Statistics (2 of 10)

```
Machine Statistics (2 of 10)
Cylinder                               Right

Total Low Mix Run Time                 0000 hr
    Last 24hrs                          0000 min
    Last 7days                          0000 hr
```

The Machine Statistics screen 2 of 10 shows the low mix running time. This is the total time, including serve mode and sleep mode, that the freezing cylinder was operating with a low mix error. The screen shows a running total, the total for the previous day and the total for the previous week.

C. Machine Statistics (3 of 10)

```
Machine Statistics (3 of 10)
Cylinder                               Right

Last Clean Cycle                       00/00/00
                                         00:00:00 AM

Last Clean Total Time                   0000 min
```

The Machine Statistics screen 3 of 10 provides the time and date that the freezing cylinder was last cleaned. This value is recorded when the Clean button is pressed on the touchpad. The screen also shows how long the most recent clean mode lasted.

D. Machine Statistics (4 of 10)

```
Machine Statistics (4 of 10)
Cylinder                               Right

Spigot Open Total                       0000 min
    Last 24hrs                           0000 min
    Last 7days                           0000 min
Spigot Total Cycles                      0000
Average Spigot Open                      0000 sec
```

The Machine Statistics screen 4 of 10 shows the total time that the spigot has been open during serve mode. The screen shows a running total, the total for the previous day and the total for the previous week. The screen also shows the total times that the spigot has been opened.

E. Machine Statistics (5 of 10)

```
Machine Statistics (5 of 10)
Cylinder                               Right

Estimated Serve Amount                  0000 gal
    Last 24hrs                            0000 gal
    Last 7days                            0000 gal
Last Serve Reset                         00/00/00
                                         00:00:00 AM

_ Reset Serve Amount
```

The Machine Statistics screen 5 of 10 gives the estimated serve amount of the freezing cylinder based on the time the spigot is open during serve mode. The estimation is also calculated for the previous day and the previous week. The screen gives an option to reset the serve amount and shows when the last reset was done.

F. Machine Statistics (6 of 10)

Machine Statistics (6 of 10)	
Cylinder	Right
Total Compressor Run Time	0000 hr
Total Compressor Cycles	0000
Last Compressor Reset	00/00/00
	00:00:00
_ Reset Compressor Time	

The Machine Statistics screen 6 of 10 shows the total run time for the compressor and counts the total cycles. There is an option to reset the timer and the screen shows when the last reset was done. The reset should be used if the compressor is changed.

G. Machine Statistics (7 of 10)

Machine Statistics (7 of 10)	
Cylinder	Right
Total Motor Run Time	0000 hr
Total Motor Cycles	0000
Last Motor Reset	00/00/00
	00:00:00 AM
_ Reset Motor Run Time	

The Machine Statistics screen 7 of 10 shows the total run time for the drive motor and counts the total cycles. There is an option to reset the timer and the screen shows when the last reset was done. The reset should be used if the drive motor is changed.

H. Machine Statistics (8 of 10)

Machine Statistics (8 of 10)	
Cylinder	Right
Total Pump Run Time	0000 hr
Total Pump Cycles	0000
Last Pump Reset	00/00/00
	00:00:00 AM
_ Reset Pump Run Time	

The Machine Statistics screen 8 of 10 shows the total run time for the pump and counts the total cycles. There is an option to reset the timer and the screen shows when the last reset was done. The reset should be used if the pump is changed.

I. Machine Statistics (9 of 10)

Machine Statistics (9 of 10)	
Cylinder	Right
Current Hose Usage	0000 hr
Last Hose Reposition	00/00/00
	00:00:00 AM
_ Reset Hose Service Time	

The Machine Statistics screen 9 of 10 shows the amount of time the pump hose has been in use and when the last reposition was completed. There is also an option to reset the hose timer.

J. Machine Statistics (10 of 10)

Machine Statistics (10 of 10)	
Last Unit Power Up	00/00/00
	00:00:00
Avg Power KWH/Day	0 Watts

The Machine Statistics screen 10 of 10 shows when the machine was last powered on. The screen also gives an average power consumption per day.

K. Error History

Error History 25 of 25	
Type	Cylinder Sensor
Date	00/00/00 00:00:00 AM
Cylinder	Right
_ Status At Time of Error	
_ Help	

The Error History screen shows the last error that occurred. The screen shows the type of error, the time and date and the cylinder that had the error. Up to 25 errors are stored. Press the up or down arrow to scroll through the errors. Select the Status at Time of Error option to view data for the time the error occurred. The Help option explains the error and provides quick troubleshooting tips.

L. Status at Time of Error

Status at Time of Error	
Operating Mode	Off
Mix Levels	Full Level
Consistency	000.00
Input Voltage	000.0V
Motor Amps	00.000A
Ambient Temp	-000.0°F
Cylinder Temp	-000.0°F

The Status at Time of Error screen gives data for the time the error occurred.

4.8 UPDATING FIRMWARE

Updating the firmware on the IntelliTec2 is simple. Any USB flash drive will work. Download the .rom file onto the top level of the USB drive (don't put the file in a folder) and follow the instructions below.

- Unplug the machine from electrical power.
- Remove the header panel and locate the USB connector on the display module.
- Connect the USB flash drive to the display module.
- Connect power to the machine.
- The firmware will automatically update and the display will say "Stoelting Soft Serve" along with the new version number.

NOTE

If the display does not show the new revision number, make sure the .rom file is in the top level of the USB flash drive. The .rom file cannot be in any folders within the flash drive.

4.9 DRIVE BELT TENSION ADJUSTMENT

To check belt tension, refer to Figure 4-1 and follow the steps below:

 WARNING
Hazardous voltage Make sure the machine is off when disassembling for servicing. The machine must be disconnected from electrical supply before removing any access panel. Failure to disconnect power before servicing could result in death or serious injury.

- Remove the back panel.
- Use a Burroughs Belt Tension Gauge to set the tension for the drive belt. Set the belt tension to 40 lbs.
- If an adjustment is necessary, loosen the four motor plate retaining nuts, adjust belt tension then retighten the four nuts.
- Using a straightedge, check that the drive motor pulley is aligned with the speed reducer pulley. Align the pulley if necessary.

NOTE

Belt life will be increased if new drive belts are tightened after two or three weeks of operation.

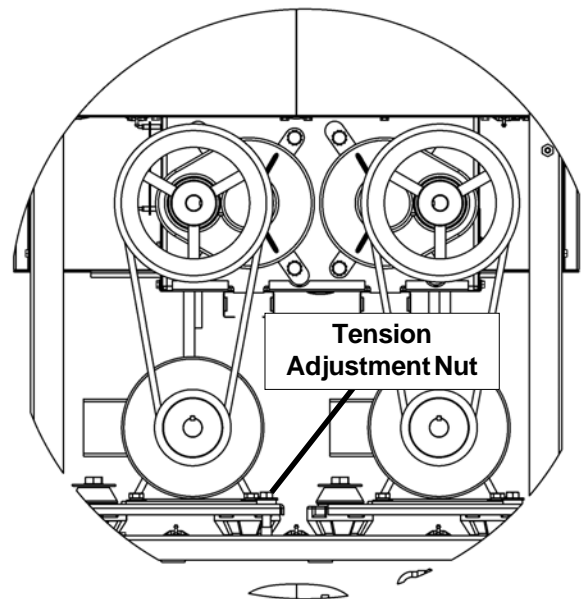

Figure 4-1 Belt Tension Adjustment

4.10 CONDENSER CLEANING

The O231 has two condensers. An air-cooled or water-cooled condenser and a condensing unit for the hopper.

The air-cooled condenser (and hopper condenser) is a copper tube and aluminum fin type. Condensing is totally dependent upon airflow. A plugged condenser, or restrictions in the louvered panel will restrict airflow. This will lower the capacity of the system and damage the compressor. The condenser must be kept clean of dirt and grease. The machine must have a minimum of 3" (7.6 cm) of ventilation at the back of the unit for free flow of air. Make sure the machine is not pulling over 100° F (37° C) air from other equipment in the area.

The water-cooled condenser is a tube and shell type. The condenser needs a cool, clean supply of water to properly cool the machine, inlet and discharge lines must be 3/8" I.D. minimum.

The air-cooled condenser and hopper condenser require periodic cleaning. To clean, refer to the following procedures.

- A. Visually inspect the condenser for dirt.
- B. If the condenser is dirty, place a wet towel over the condenser
- C. Using compressed air or CO₂ tank, blow out the dirt from the back of the condenser. Most of the dirt will cling to the wet towel.
- D. An alternative method is to clean with a condenser brush and vacuum.

NOTE

If the condenser is not kept clean, refrigeration efficiency will be lost.

4.11 PREVENTATIVE MAINTENANCE

It is recommended that a preventative maintenance schedule be followed to keep the machine clean and operating properly. The following steps are suggested as a preventative maintenance guide.

The United States department of agriculture and the food and drug administration require that lubricants used in food zones be certified for this use. Use lubricants only in accordance with the manufacturer's instructions.

- A. Daily checks
Check for any unusual noise or condition and repair immediately.
- B. Monthly checks
Check the condenser for dirt and clean if necessary.
- C. Quarterly Checks
Check drive belts for wear and tighten belts if necessary.

4.12 EXTENDED STORAGE

Refer to the following steps for storage of the machine over any long period of shutdown time:

- A. Clean all the parts that come in contact with mix thoroughly with a warm detergent water. Rinse in clear water and dry all parts. Do not sanitize.

NOTE

Do not let cleaning solution stand in the freezing cylinder or hopper during the shutdown period.

- B. Remove, disassemble, and clean the front door, and auger shaft. Leave disassembled during the shutdown period.
- C. Place the auger flights and auger support bushing in a plastic bag with a moist paper towel. This will prevent them from becoming brittle if exposed to dry air over an extended period of time (over 30 days).
- D. For water-cooled machines that are left in unheated buildings, or buildings subject to freezing, the water must be shut off and disconnected. Disconnect the water inlet fitting. The fitting is located at the rear of the machine. Run the compressor for 2 - 3 minutes to open water valve (the front door must be attached for the compressor to run). Blow out all water through water inlet. Drain the water supply line coming to the machine. Disconnect the water outlet fitting.
- E. Press the Main Power On/Off button to turn the machine off.
- F. Disconnect the machine from the source of electrical supply.

SECTION 5 REFRIGERATION SYSTEM

5.1 REFRIGERATION SYSTEM

The O231 has three separate refrigeration systems; one for each freezing cylinder and one for the hoppers.

The freezing cylinder systems are designed for use with R404A refrigerant and the hopper system is designed for use with R134A refrigerant. The proper charges are indicated on the information plate.

5.2 REFRIGERANT RECOVERY AND EVACUATION

Refer to the following procedures to properly recover and evacuate the refrigeration system. Do not purge refrigerant into the atmosphere.

NOTE

For qualified service personnel only. Anybody working with refrigerants must be certified as a Technician TYPE I as required by 40 CFR 82 Subpart F and hold all State and/or local refrigerant handling certifications. In addition, all handling, storage, and disposal of refrigerants must be in accordance with Environmental Protection Agency (EPA) guidelines and standards and all State and local guidelines and standards.

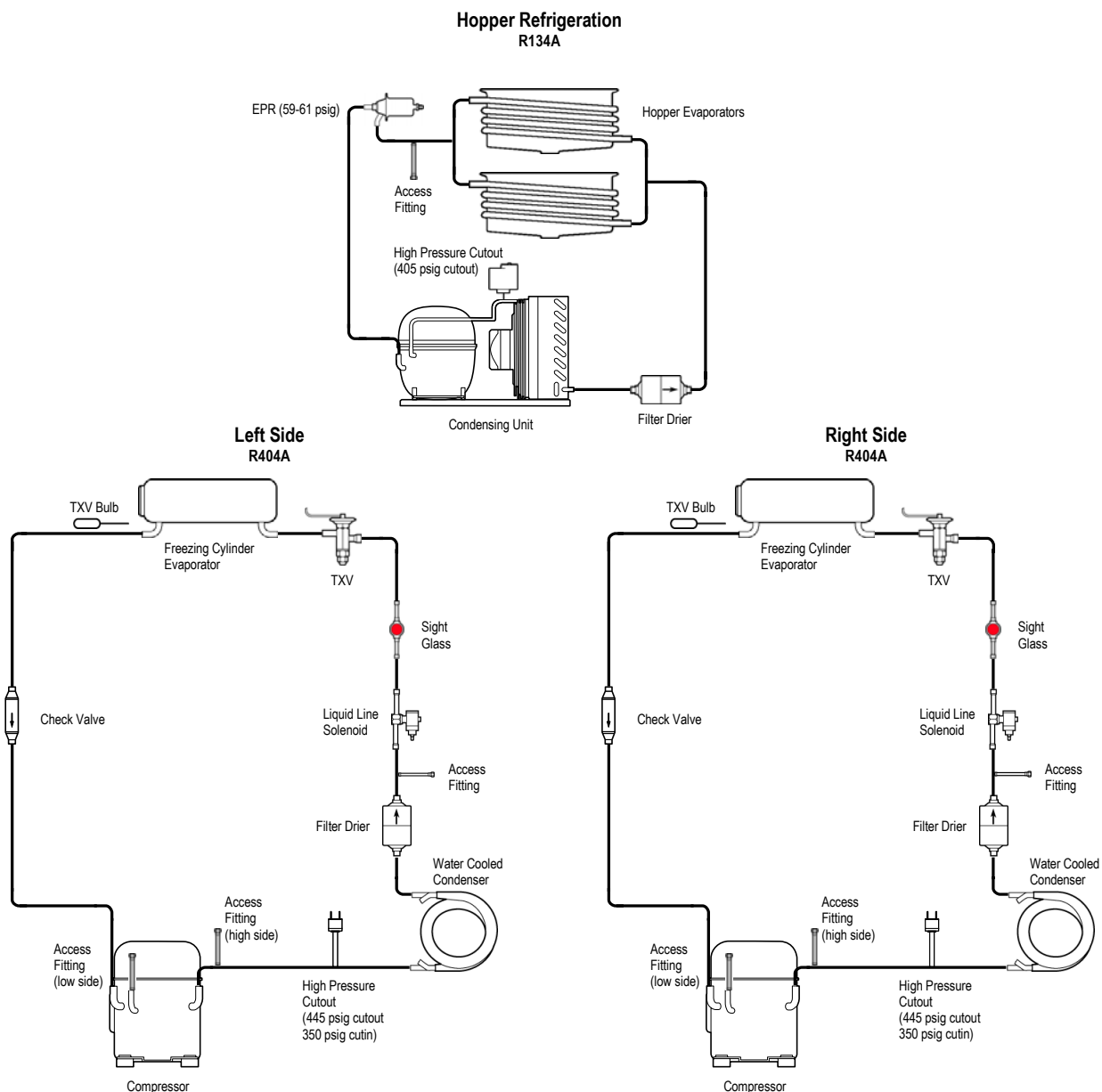

Figure 5-1 Water Cooled Refrigeration System



WARNING

Hazardous voltage

Make sure the machine is off when disassembling for servicing. The machine must be disconnected from electrical supply before removing any access panel. Failure to disconnect power before servicing could result in death or serious injury.

A. REFRIGERANT RECOVERY

1. Disconnect the machine from electrical supply before removing any panels for servicing.
2. Remove all panels.
3. Connect the recovery unit to the suction and discharge service valves of the compressor.
4. Connect power to the machine.
5. Turn the machine on by pressing the Main Power Off/On button.
6. Press the right arrow, SET, then the SEL button to access the technician level on the control.
7. Activate the Liquid Solenoid on the left side or the right side. Activating the solenoids is done through the Left Output Control or Right Output Control menus which are located under Utilities in the Testing and Manual Operation screen. Refer to Section 4 for details.

CAUTION

The solenoid valves must be energized to allow all refrigerant to be recovered and to prevent injury when brazing.

8. Operate the recovery unit per manufacturer's instructions
9. After recovery is complete, deactivate the solenoid by exiting the Testing and Manual Operation screens.

B. EVACUATING THE REFRIGERATION SYSTEM

1. Close any open ports in the refrigeration system.
2. Connect a vacuum gauge to one of the Schrader valves next to an evaporator.
3. Connect the evacuation unit to the suction and discharge service valves of the compressor.
4. Connect power to the machine.
5. Turn the machine on by pressing the Main Power Off/On button.
6. Press the right arrow, SET, then the SEL button to access the technician level on the control.

7. Activate the Liquid Solenoid on the left side or the right side. Activating the solenoids is done through the Left Output Control or Right Output Control menus which are located under Utilities in the Testing and Manual Operation screen. Refer to Section 4 for details.
8. Evacuate the system until the gauge reads 300 microns of mercury (300 μ Hg) for 5 continuous minutes.
10. If the system will not maintain a standing vacuum test with the vacuum pump off (gauge increases towards atmosphere), find the leak, fix it, and evacuate again.
11. After evacuating is complete, deactivate the solenoid by exiting the Testing and Manual Operation screens.

5.3 REFRIGERANT CHARGING

Refer to the following procedures to properly charge the refrigeration system. Stoelting recommends liquid refrigerant charging.

NOTE

For qualified service personnel only. Anybody working with refrigerants must be certified as a Technician TYPE I as required by 40 CFR 82 Subpart F and hold all State and/or local refrigerant handling certifications. In addition, all handling, storage, and disposal of refrigerants must be in accordance with Environmental Protection Agency (EPA) guidelines and standards and all State and local guidelines and standards.

- A. Ensure the electrical supply has been removed before continuing.
- B. If the system has been opened or if there was a leak, refer to Section 5.2 - Refrigerant Recovery and Evacuation to evacuate the system prior to charging.
- C. Refer to machine's information plate for total charge requirements.

NOTE

The refrigeration system of the O231 is critically charged. Be sure to charge the system to the weight listed on the machine's information plate.

- D. For liquid refrigerant charging, connect refrigerant cylinder to the discharge Schrader valve of the compressor.
- E. Energize the solenoid valve.
- F. Add the proper amount of refrigerant according to the machine's information plate.

5.4 COMPRESSOR

The O231 has three hermetic reciprocating compressors: two for the freezing cylinders and one for the hoppers. (Refer to Figure 5-2 and 5-3).

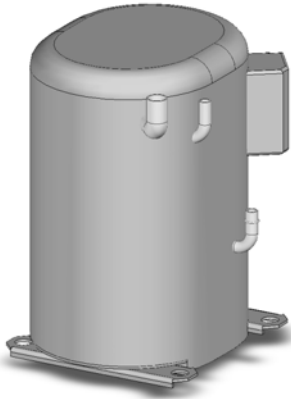

Figure 5-2 Freezing Cylinder Compressor

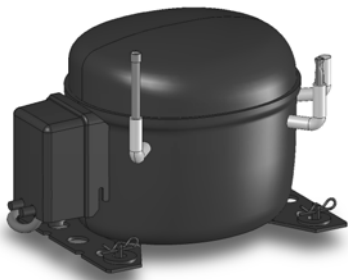

Figure 5-3 Hopper Compressor

A. WINDING TEST

To test the motor windings for possible problems, perform the following steps:

- A. Disconnect the machine from electrical supply before removing any panels for servicing.



WARNING

Hazardous voltage

Make sure the machine is off when disassembling for servicing. The machine must be disconnected from electrical supply before removing any access panel. Failure to disconnect power before servicing could result in death or serious injury.

- B. Remove the panels to gain access to the compressor terminals.
- C. Remove the protective cover from the compressor terminals. Disconnect the three terminals; C (common), R (run), and S (start).
- D. Connect an ohmmeter to the C and R terminals on the compressor. Resistance through the run winding should be as follows:
Freezing Cylinder Compressor: $0\Omega \pm 10\%$
Hopper Compressor: $10.2\Omega \pm 10\%$
- E. Connect an ohmmeter to the C and S terminals on the compressor. Resistance through the start winding should be as follows:
Freezing Cylinder Compressor: $1.609\Omega \pm 10\%$
Hopper Compressor: $16.4\Omega \pm 10\%$
- F. To check if windings are shorted to ground, connect one ohmmeter lead to a bare metal part on the compressor (such as any copper line leading to or from the compressor) and check terminals C, R, and S.

B. COMPRESSOR REMOVAL

- A. Disconnect the machine from electrical supply before removing any panels for servicing.
- B. Remove the back panel.
- C. Remove the protective cover from the compressor terminals and disconnect the wires.
- D. Recover refrigerant charge per the instructions in Section 5.2.
- E. Leave the suction and discharge ports open to prevent pressure buildup during compressor removal.
- F. Remove six inches of insulating tubing on the suction line going to the compressor and unsweat the suction and discharge line from the compressor.
- G. Remove the four nuts and washers from the base of the compressor.
- H. Remove the compressor through the front of the machine.
- I. Remove the four rubber compressor mounts from the compressor.
- J. Crimp and braze all open ports of the old compressor.

NOTE

A compressor returned to Stoelting with any open ports will void the warranty. ALWAYS crimp and braze ports on a compressor that has been removed.

C. COMPRESSOR INSTALLATION

- A. Make sure the machine is disconnected from the electrical supply before servicing.
- B. Install the four rubber mounts on the compressor.
- C. Install the compressor into the machine, fitting the base over the four bolt holes.
- D. Install the four washers and nuts onto the bolts and tighten securely.
- E. Remove all tubing plugs from the replacement compressor.

NOTE

The compressor plugs protect the compressor from moisture in the air. Do not remove the plugs until you are ready to install. The compressor must not be opened to the atmosphere for more than 10 minutes.

- F. Leave the suction and discharge ports open to prevent pressure buildup. Braze the suction and discharge line to the compressor.
- G. Connect the wires to the compressor terminals.
- H. Replace the drier per the instructions in Section 5.9.
- I. Evacuate the system per the instructions in Section 5.2
- J. Recharge the system per the instructions in Section 5.3.
- K. Replace the insulating tubing on the suction line.

5.5 CONDENSER

The O231 is available with either an air-cooled or a water-cooled condenser. The capacity of the machine is directly related to keeping the condenser clean and free of debris.

The air-cooled condenser is a copper tube and aluminum fin type. The machine must have a minimum of 3" of clearance on both sides and at the back for proper air flow.

The water-cooled condenser is a tube and shell type. This condenser requires cool, clean water to function properly. Inlet and discharge lines must be 3/8" ID minimum.

CONDENSER TESTING

The condenser can be checked for leaks using the bubble test or using a leak detector.

5.6 VALVES

A. THERMOSTATIC EXPANSION VALVE (TXV)

The Thermostatic Expansion Valve (TXV) is used to meter the refrigerant to the freezing cylinder evaporator. It does so by maintaining a constant pressure in the evaporator. The self-regulating TXV is preset by the manufacturer and adjustment is not recommended. Figure 5-4.

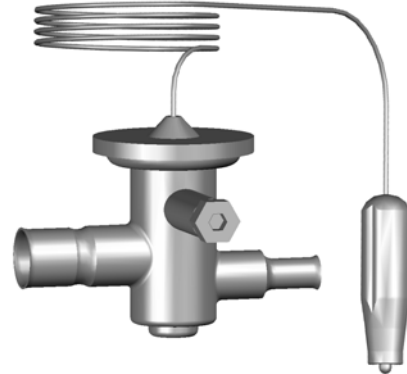

Figure 5-4 TXV

TXV TESTING & ADJUSTMENT

NOTE

The bulb has an indent which must be positioned against the tubing. Good contact between the bulb and the suction line is necessary for proper operation of the valve. The bulb must also be well insulated.

- A. Connect a gauge to the Schrader valve on the suction line.
- B. Connect a thermocouple to the suction line next to the evaporator.
- C. Immediately before the refrigeration cycle ends, the gauge should read between 20-22 psig. The superheat should be 7-10°F.
- D. If the pressure reading is higher than expected and the superheat is low, check to see if there is an overcharge of refrigerant.
- E. If the pressure reading is lower than expected and the superheat is high, check to see if there is a low refrigerant charge or if there is a restriction in the system.

NOTE

The TXV is the LAST component to adjust in the refrigeration system.

- F. The TXV can be adjusted after the steps above are completed. When adjusting, do not turn the valve over 1/4 turn (90°). Turn the valve stem clockwise to increase the superheat or counterclockwise to decrease the superheat.

TXV REMOVAL

- A. Remove the side panel.

 WARNING
Hazardous voltage Make sure the machine is off when disassembling for servicing. The machine must be disconnected from electrical supply before removing any access panel. Failure to disconnect power before servicing could result in death or serious injury.

- B. Remove bulb from suction line exiting from the evaporator.
- C. Recover refrigerant charge per instructions in Section 5.2.
- D. Leave the suction and discharge ports open to prevent pressure buildup during TXV removal.
- E. Remove any insulation from the TXV and immediate surrounding lines.
- F. Apply a heat sink (wet cloth) to the valve dome (Figure 5-5).



Figure 5-5 TXV Removal

- G. Unsweat the TXV and remove.

TXV REPLACEMENT

To replace the TXV, perform the following procedures:

- A. Position the TXV with a heat sink into the system.
- B. With the suction and discharge ports open, braze the TXV into the system using appropriate brazing material.
- C. Remove the heat sink from the TXV.

- D. Install bulb on suction line exiting the evaporator using existing clamp. The bulb has an indent which must be placed against the tubing.

NOTE

Good contact between the bulb and the suction line is necessary for proper operation of the valve. The bulb must also be well insulated.

- E. Tighten clamp to 20 in/lb using a torque wrench.
- F. Replace insulation to the TXV and surrounding lines.
- G. Replace the drier per the instructions in Section 5.9.
- H. Evacuate the system per the instructions in Section 5.2.
- I. Recharge the system per the instructions in Section 5.3.

B. AUTOMATIC EXPANSION VALVE (AXV) (YG2 MODELS ONLY)

The Automatic Expansion Valve (AXV) is used to meter the refrigerant to the freezing cylinder evaporator in YG2 model machines. It does so by maintaining a constant pressure in the evaporator. The self-regulating AXV is preset by the manufacturer and adjustment is not recommended. Figure 5-6.

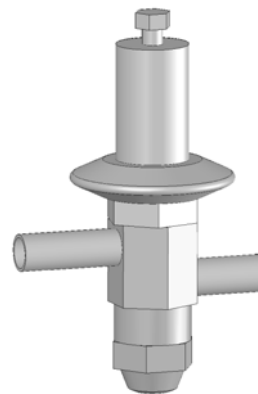

Figure 5-6 AXV

AXV TESTING & ADJUSTMENT

- A. Connect a gauge to the Schrader valve on the suction line next to the evaporator.
- B. Connect a thermocouple to the suction line next to the evaporator.
- C. Immediately before the refrigeration cycle ends, the gauge should read 20-22 psig. This reading is based on a full load in the freezing cylinder and an ambient temperature of 70°F.
- D. If the pressure reading is higher than expected, check to see if there is an overcharge of refrigerant.

- E. If the pressure reading is lower than expected, check to see if there is a low refrigerant charge or if there is a restriction in the system.

NOTE

The AXV is the LAST component to adjust in the refrigeration system.

- F. The AXV can be adjusted after the steps above are completed. When adjusting, do not turn the valve over 1/4 turn (90°). Turn the valve stem clockwise to decrease the evaporator pressure or counterclockwise to increase the evaporator pressure.



Figure 5-6 Check Valve

AXV REMOVAL

- A. Disconnect the machine from electrical supply before removing any panels for servicing. Remove the the front panel.
- B. Recover refrigerant charge per instructions in Section 5.2.
- C. Leave the suction and discharge ports open to prevent pressure buildup during AXV removal.
- D. Remove any insulation from the AXV and immediate surrounding lines.
- E. Apply a heat sink (wet cloth) to the valve dome.
- F. Unsweat the AXV and remove.

AXV REPLACEMENT

To replace the AXV, perform the following procedures:

- A. Position the AXV, with a heat sink, into the system.
- B. With the suction and discharge ports open, braze the AXV into the system.
- C. Remove the heat sink from the AXV.
- E. Replace insulation to the AXV and surrounding lines.
- F. Replace the drier per the instructions in Section 5.9.
- G. Evacuate the system per the instructions in Section 5.2.
- H. Recharge the system per the instructions in Section 5.3.

C. CHECK VALVE

The machine has 2 magnetic check valves (Refer to Figure 5-6). Each valve is positioned in the suction line and prevents backflow of refrigerant into the evaporator. If there is reversed flow, the product in the freezing cylinder softens and liquid refrigerant can flood into the compressor on startup.

If a check valve needs to be replaced, use a heat sink (wet cloth) when installing the new valve to prevent damage.

D. HIGH PRESSURE CUTOUT

There is a high pressure cutout for each freezing cylinder (Fig 5-7) and one for the hopper refrigeration (Fig 5-8). The high pressure cutout stops the compressor if the discharge pressure reaches the cutout, 445 psig for the freezing cylinders and 405 psig for the hopper.

The high pressure cutout for the freezing cylinders automatically reset. The cutout for the hopper refrigeration is a manual reset located behind the back panel.



Figure 5-7 High Pressure Cutout Freezing Cylinders

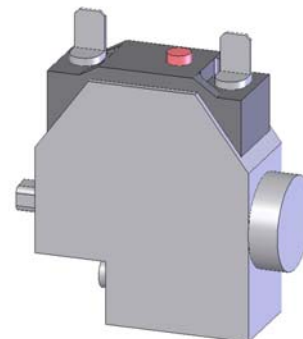

Figure 5-8 High Pressure Cutout Hopper Refrigeration

HIGH PRESSURE CUTOUT TEST

- A. Connect a gauge to the Schrader valve on the discharge line.



WARNING

Hazardous voltage

Make sure the machine is off when disassembling for servicing. The machine must be disconnected from electrical supply before removing any access panel. Failure to disconnect power before servicing could result in death or serious injury.

- B. Disconnect cooling:
 - In a water-cooled machine, shut off the water supply.
 - In an air-cooled machine, shut off the fan motor in the IntelliTec2 control. Refer to Section 4.6 for details.
 - For the hopper fan, disconnect the fan motor.
- C. High pressure cutout should trip when pressure reaches 445 psig \pm 9 in the freezing cylinder system and 405 psig in the hopper system.

HIGH PRESSURE CUTOUT REMOVAL

- A. Remove the side panel.
- B. Recover refrigerant charge per instructions in Section 5.2.
- C. Leave the suction and discharge ports open to prevent pressure buildup during removal.
- D. Unsweat capillary tube from suction line.
- E. Disconnect terminals from high pressure cutout.

HIGH PRESSURE CUTOUT REPLACEMENT

- A. With the suction and discharge ports open, braze the capillary tube to the discharge line.
- C. Replace the drier per the instructions in Section 5.9.
- D. Braze bulb into place on suction line.
- E. Evacuate the system per the instructions in Section 5.2.
- F. Recharge the system per the instructions in Section 5.3.
- G. Connect the terminals to the high pressure cutout.
- H. Attach the high pressure cutout using the two screws with star washers.

E. EVAPORATOR PRESSURE REGULATOR (EPR)

There is one EPR in the refrigeration system (Refer to Figure 5-9). It is located on the suction line of the hopper evaporators and regulates evaporator refrigerant pressure.

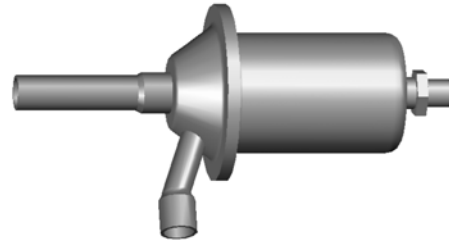

Figure 5-9 EPR Valve

EPR TEST AND ADJUSTMENT

Adjustment to the EPR must be made when the hopper refrigeration is running

- A. Disconnect the machine from electrical supply before removing any panels for servicing.
- B. Remove the left side panel.
- C. Connect a gauge to the Schrader valve on the suction line between the hopper evaporators and the EPR.
- D. Connect power to the machine.
- E. Turn the machine on by pressing the Main Power Off/On button. Listen for the hopper compressor to start.
- F. The gauge should read 25-26 psig. If it does not, then adjustment is needed.
- G. Remove the plastic cap and loosen the locknut on the EPR. Using a small screwdriver, turn the adjustment screw counterclockwise 1/2 turn, then adjust as necessary. Turn the valve stem clockwise for higher pressure or counterclockwise for lower pressure.
- H. Allow the system to stabilize for 5 minutes to ensure pressure remains stable.

EPR REMOVAL

- A. Remove the left side panel.
- B. Recover refrigerant charge per instructions in Section 5.2.
- C. Leave the suction and discharge ports open to prevent pressure buildup during EPR removal.
- D. Unsweat the EPR and remove.

EPR REPLACEMENT

To replace the EPR, perform the following procedures:

- A. Apply a heat sink (wet cloth) to the EPR.
- B. With an open port, braze the EPR into the system.
- C. Remove the heat sink from the hot gas bypass.
- D. Replace the filter drier. Refer to Section 5.8 for details.
- E. Evacuate and recharge system per instructions in Section 5.2.

F. WATER VALVE (WATER COOLED MODELS ONLY)

The water valve monitors refrigerant pressure and opens on an increase of pressure. The opening point pressure is the refrigerant pressure required to lift the valve disc off the valve seat. (Figure 5-10)

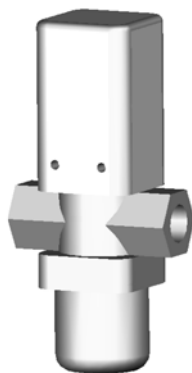

Figure 5-10 Water Valve

WATER VALVE ADJUSTMENT

- A. Remove the lower front panel and side panel.
- B. Connect a gauge to the compressor discharge Schrader valve.
- C. Connect the machine to the electrical supply, start the refrigeration cycle, and read the pressure.
- D. The proper gauge reading should be 235-245 psig. The exit water temperature should be 95-107°F.
- E. If the water temperature and high side pressure are too low, the opening point pressure should be increased to slow the water flow. Turn the adjustment screw counterclockwise.
- F. If the water temperature and high side pressure are too high, the opening point pressure should be decreased to increase the flow of water. Turn the adjustment screw clockwise.

WATER VALVE REMOVAL

The water valve is connected to the refrigeration system by capillary tube brazed to the discharge line.

- A. Turn off and disconnect the water supply. Blow out the water lines with compressed air or CO₂.
- B. Recover refrigerant charge per instructions in Section 5.2.

- C. Leave the suction and discharge ports open to prevent pressure buildup during water valve removal.
- D. Unsweat the capillary tube from the discharge line.
- E. Remove the clamps from the water lines at the valve.
- F. Remove the two screws holding the water valve to the frame and remove the valve.

WATER VALVE REPLACEMENT

To replace the water valve, perform the following procedures:

- A. Position the water valve and attach to the frame using the two screws.
- B. Install the water lines onto the valve with hose clamps.
- C. Leave the suction and discharge ports open to prevent pressure buildup during water valve installation.
- D. Braze the capillary tube into the system.
- E. Connect the water supply line and turn on the water supply.
- F. Check for leaks in the water lines. If there are no leaks, turn off the water supply.
- G. Replace the filter drier. Refer to Section 5.8 for details.
- H. Evacuate and recharge system per instructions in Section 5.2.
- I. Turn on the water and check for leaks in the water lines with the refrigeration system running.
- J. Adjust the valve as necessary.

5.7 SOLENOID

Solenoid valves are installed on the liquid lines of each freezing cylinder evaporator. A solenoid valve has a magnetic coil that, when energized, lifts a plunger and allows refrigerant to flow. The solenoids are activated by the IntelliTec2 control.

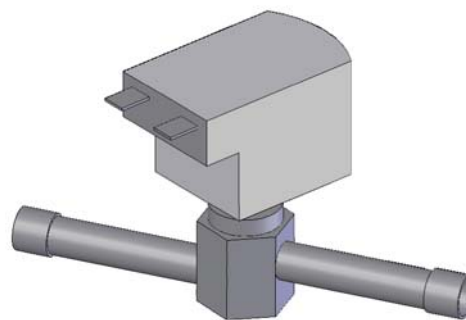

Figure 5-11 Solenoid Valve

ACTIVATING A SOLENOID

To activate a solenoid, follow these steps:

- A. Turn the machine on by pressing the Main Power Off/On button.
- B. Press the right arrow, SET, then the SEL button to access the technician level on the control.
- C. Navigate to the Left Output Control or Right Output Control menu which is located under Utilities in the Testing and Manual Operation screen. Refer to Section 4 for details.
- D. Activate the solenoid by moving the cursor to the Liquid Solenoid option and pressing the SET button.

NOTE

Any energized component will deenergize after leaving the Testing and Manual Operations menu.

SOLENOID TESTING

The following test will check if a liquid line solenoid has a leaking valve seat. The power to the solenoid is disconnected and refrigerant flow is monitored through the system. If the valve seat does not leak, the suction pressure during the test will be low.

- A. Attach a gauge to the Schrader valve on the suction line.
- B. Turn the machine on by pressing the Main Power Off/On button.
- C. Press the right arrow, SET, then the SEL button to access the technician level on the control.
- D. Navigate to the Left Output Control or Right Output Control menu which is located under Utilities in the Testing and Manual Operation screen. Refer to Section 4 for details.
- E. Activate the compressor by moving the cursor to the compressor option and pressing the SET button.
- F. The gauge should read well below 21 psig after 1 minute.
- G. A leaking valve seat may also show frost on the liquid line tubing just past the solenoid and before the evaporator.

SOLENOID MAGNETIC COIL REMOVAL

- A. Remove the side panel.
- B. Disconnect the electrical wires.
- C. Remove the retainer screw from the top of the solenoid and pull the magnetic coil off.

SOLENOID MAGNETIC COIL INSTALLATION

To replace the magnetic coil, perform the following procedures:

- A. Push the coil on to the solenoid valve stem.
- B. Connect the two electrical wires to the magnetic coil.
- C. Make sure there isn't any foam insulation between the valve coil and valve body. Trim any excess insulation.
- D. Install retainer screw onto top of coil.

SOLENOID VALVE REMOVAL

- A. Identify and disconnect the two wires from the solenoid coil.
- B. Remove the retainer holding the coil to the solenoid body and remove the coil.
- C. Recover refrigerant charge per instructions in Section 5.2.
- D. Remove insulation around valve and attached refrigeration lines.
- E. Apply heat sinks (wet cloth) to the insulated refrigerant lines near the valve.
- F. Leave a port open to prevent pressure buildup during solenoid removal
- G. Unsweat the solenoid and remove.

SOLENOID VALVE REPLACEMENT

To replace the solenoid, perform the following procedures:

- A. Position the new solenoid with the arrow pointing toward the direction of refrigerant flow.
- B. Apply a heat sink (wet cloth) to the solenoid valve.
- C. With the suction and discharge ports open, braze the solenoid into the system.
- D. Remove the heat sink from the valve.
- E. Replace insulation around valve.
- F. Replace the filter drier. Refer to Section 5.8 for details.
- G. Evacuate and recharge system per instructions in Section 5.2.

5.8 FILTER DRIER

The filter drier must be replaced every time the refrigeration system is opened for service. A new filter drier improves operation of the entire refrigeration system by stopping the circulation of moisture and by removing harmful contaminants (Refer to Figure 5-12).

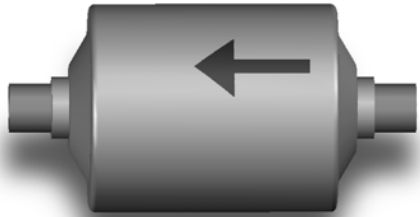

Figure 5-12 Filter Drier

FILTER DRIER REMOVAL

- A. Recover refrigerant charge per instructions in Section 5.2.
- B. Cut the refrigeration line as close to the filter drier as possible and remove drier.
- C. Cap the ends of the drier using the plugs from the new drier.

NOTE

The drier must be capped to prevent moisture from the environment

FILTER DRIER REPLACEMENT

- A. Position the filter drier so the arrow is pointing toward the direction of refrigerant flow (pointing away from the condenser).
- B. Apply a heat sink (wet cloth) to the filter drier.
- C. With the suction and discharge ports open, braze the filter drier into the system.
- D. Evacuate the system per instructions in Section 5.2.
- E. Recharge the system per instructions in Section 5.3.

SECTION 6 ELECTRICAL AND MECHANICAL CONTROL SYSTEMS

NOTE

The wiring diagram is available in Section 8.

6.1 INTELLITEC2 CONTROL

The IntelliTec2 control consists of three main components; a control board, a display board and a membrane switch (touchpad).

The control board is modular and consists of a program board and a relay board. The two boards make it easy to service and replace. The boards are connected by two screws.

6.2 CONTACTORS

The O231 has a total of six contactors. Each side of the machine has a contactor for the compressor, drive motor and IntelliTec2 control. The contactor for the IntelliTec2 provides power to the fan motor (in air-cooled machines) and the condensing unit for the hoppers.

All of the contactors are located in the electrical box behind the right side panel.

The IntelliTec2 control sends electronic signals to trigger the contactors. Separate signals are used to control each drive motor contactor and each compressor contactor. The signals to the contactors are staggered, so the drive motor will always start three seconds before the compressor. By staggering the starting and stopping of the drive motor, maximum starting torque is available and voltage spikes are reduced.



Figure 6-2 Display Board

A. CONTACTOR TESTS

The following tests will show if a contactor is working properly.

1. Listen for the contactor to close. When the spigot is opened or the Push To Freeze button is pressed, the drive motor contactor will close. After three seconds, the compressor contactor will close.

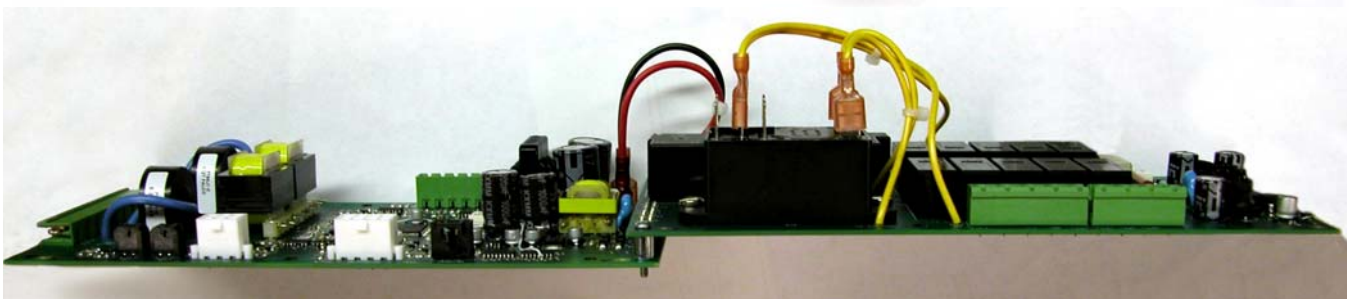

Figure 6-1 IntelliTec2 Control Board

2. Check to ensure contactor is receiving signal. Read voltage across the coils of the contactor during a freezing cycle. Voltage should be about 230V. If there is no voltage reading, refer to Section 7 Troubleshooting.

6.3 DRIVE MOTOR

The O231 has two drive motors. They are used to rotate the auger assemblies. An internal, normally closed, centrifugal switch starts the drive motor. The motors have an internal thermal overload.

A. DRIVE MOTOR TEST

1. Turn the machine off by pressing the Main Power Off/On button and disconnect the machine from the electrical supply.
2. Remove the back panel and a side panel.
3. Loosen the belt tension adjustment nut and remove the belt.
4. Connect power to the machine.
5. Turn the machine on by pressing the Main Power Off/On button.
6. Press the right arrow, SET, then the SEL button to access the technician level on the control.



WARNING

Hazardous voltage

Make sure the machine is off when disassembling for servicing. The machine must be disconnected from electrical supply before removing any access panel. Failure to disconnect power before servicing could result in death or serious injury.

7. Activate the drive motor through the Left Output Control or Right Output Control menus which are located under Utilities in the Testing and Manual Operation screen. Refer to Section 4 for details.
8. Go to the Test Monitoring screen under Utilities. The motor current should be as follows:
Single Phase Machines: 6.1-6.3 Amps
Three Phase Machines: 4.0-4.2 Amps

NOTE

The motor amps are based on 230VAC supply voltage.

9. After the test, stop the motor by exiting the Testing and Manual Operation section. Turn the machine off and disconnect from the electrical supply.
10. Install the belt and tighten the tension bolt.
11. Use a Burroughs Belt Tension Gauge to set the tension for the drive belt. Set the belt tension to 40 lbs.
12. Using a straightedge, align the drive motor pulley with the gearbox pulley. Tighten the two allen head screws.

B. DRIVE MOTOR REMOVAL

1. Disconnect machine from electrical supply before removing any panels for servicing.
2. Remove the back panel and the side panel.
3. Remove the electrical cover plate from the back of the motor.
4. Identify (mark) wires and remove them from the motor.
5. Loosen the belt tension adjustment bolt and remove the belt. (Refer to Figure 6-3)

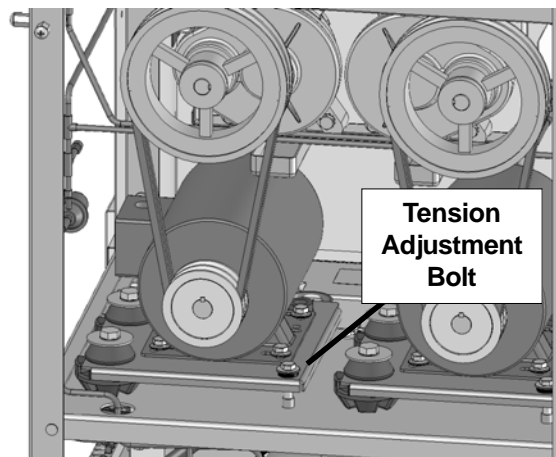

Figure 6-3 Motor Mounting

7. Remove the motor mounting bolts.
8. Loosen the two allen head screws from the pulley.
9. Remove the pulley and key from the motor shaft.

C. DRIVE MOTOR INSTALLATION

1. Place the drive motor in position and install the four mounting bolts.
2. Place the pulley and key on the motor shaft.

NOTE

Do not tighten the pulley screws until after the belt tension has been properly adjusted.

3. Install the belt and tighten the tension adjustment bolt.
4. Use a Burroughs Belt Tension Gauge to set the tension for the drive belt. Set the belt tension to 40 lbs.
5. Using a straightedge, align the drive motor pulley with the gearbox pulley. Tighten the two allen head screws.
6. Install wiring according to wiring diagram (located behind the left side panel). Install electrical cover plate on the motor.
7. Install back and side panels.

6.4 CAPACITORS

The compressor start and run capacitors are only on single phase machines. They are accessible by removing the right side panel.

The start and run capacitors for the drive motors are mounted directly onto each motor body.

A. CAPACITOR TEST

1. Disconnect machine from electrical supply before removing any panels for servicing.

 WARNING
<p>Hazardous voltage Make sure the machine is off when disassembling for servicing. The machine must be disconnected from electrical supply before removing any access panel. Failure to disconnect power before servicing could result in death or serious injury.</p>

2. Remove a lead from one of the capacitor terminals.
3. Using insulated pliers, discharge the capacitor by connecting a 20KΩ 5W resistor across the terminals.

NOTE

Discharge the capacitor even if there is a bleeder resistor across the terminals. There may be an open in the bleeder resistor preventing it from working properly.

4. Disconnect the bleeder resistor from the circuit.
5. Measure the capacitance across the terminals. The results should be as follows:

	Part	Rating	
		MFD	VAC
Drive Motor Start	230622	200 MFD	250 VAC
Drive Motor Run	231075	30 MFD	370 VAC
Compressor Start	231058	145-174 MFD	250 VAC
Compressor Run	231057	35 MFD	370 VAC

B. CAPACITOR REPLACEMENT

1. Disconnect machine from electrical supply before removing any panels for servicing.
2. Remove leads from the capacitor terminals.
3. Using insulated pliers, discharge the capacitor with a 20KΩ 5W resistor across the terminals.

NOTE

Discharge the capacitor even if there is a bleeder resistor across the terminals. There may be an open in the bleeder resistor preventing it from working properly.

4. Pull the capacitor out of its holder and replace.
5. Connect the leads to the terminals of the new capacitor.

6.5 GEARBOX

A. GEARBOX INSPECTION

Inspect the gearbox and listen for unusual noise. A grinding sound generally indicates a bad gear.

B. GEARBOX REMOVAL

1. Disconnect machine from electrical supply before removing any panels for servicing.
2. Remove the back panel and the side panel.
3. Remove the belts.
4. Remove the bolts holding the gearbox assembly and remove it.

C. GEARBOX INSTALLATION

1. Place the gearbox in position from the rear of the machine. Fasten the bolts through the gearbox to the rear of the barrel.
2. Mount the pulley on the gearbox shaft and align with the motor pulley, then tighten the allen head screws.
3. Install the belt.
4. Use a Burroughs Belt Tension Gauge to set the tension for the drive belt. Set the belt tension to 40 lbs.
5. Using a straightedge, align the drive motor pulley with the gearbox pulley. Tighten the two allen head screws.

6.6 CONDENSER FAN MOTOR (AIR-COOLED ONLY)

The fan motor is connected to a toggle switch located behind the left side panel. The switch is connected to a buck-boost transformer. The switch must be set to the correct position based on input voltage.

The buck-boost transformer is connected to an overload protector. This protects against the switch being in the wrong position, a faulty switch and/or wiring issues.

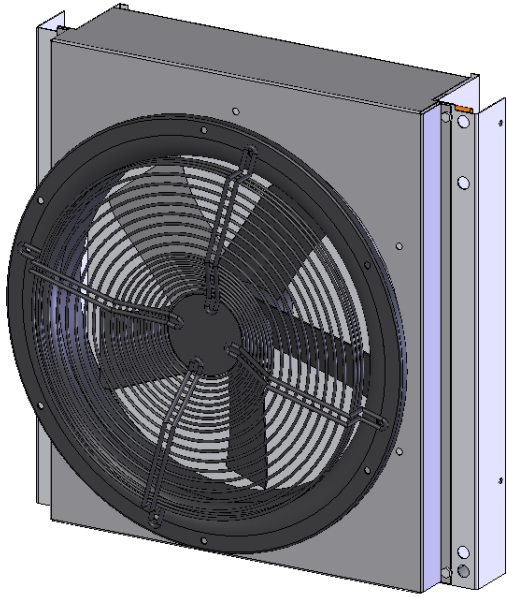

Figure 6-4 Condenser

A. CHECK VOLTAGE

1. With the machine connected to power and the main power on, press the right arrow, SET, then the SEL button to access the technician level on the control.



WARNING

Hazardous voltage

Make sure the machine is off when disassembling for servicing. The machine must be disconnected from electrical supply before removing any access panel. Failure to disconnect power before servicing could result in death or serious injury.

2. Go to the Performance screen. Refer to Section 4 for details.

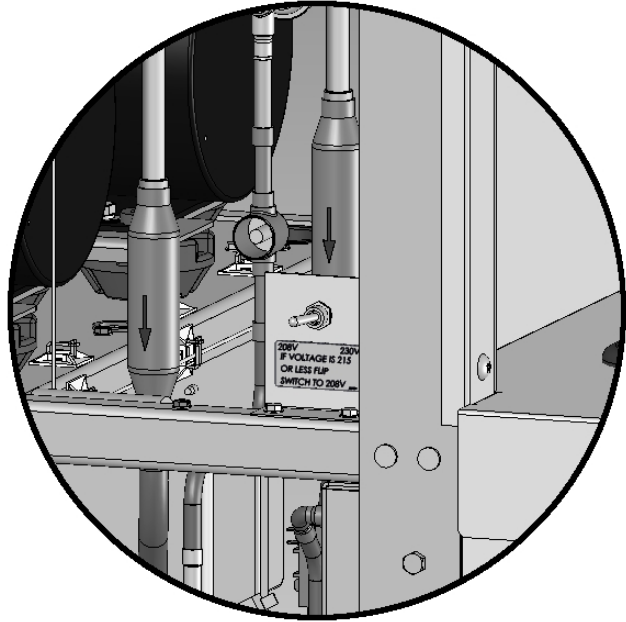

Figure 6-5 Buck-Boost Transformer Toggle Switch

3. If the Input Voltage listed on the Performance screen is 215VAC or less, set the toggle switch to 208. If the voltage is above 215VAC, set the toggle switch to the 230.

NOTE

The voltage reading must be taken to ensure the fan motor works properly.

B. FAN MOTOR REPLACEMENT

1. Disconnect machine from electrical supply before removing any panels for servicing.
2. Remove a side panel and the header panel.
3. Trace and disconnect the brown and blue wires on the fan motor.
4. Remove the fan guard and the fan motor assembly.
5. Remove the torx screws from the fan guard.
6. Remove the bolts holding the fan guard to the condenser shroud.

C. FAN MOTOR INSTALLATION

1. Rotate the fan motor so the mounting holes are lined up with the holes in the fan guard.
2. Install the fan to the fan guard using the torx screws.
3. Move the fan and fan guard into place.
4. Install the fan guard to the shroud with the four bolts.
5. Wire the fan motor according to the wiring diagram. The buck-boost transformer must be connected if necessary (see above regarding checking voltage).

6.7 SPIGOT SWITCH

The spigot switch is a normally closed, held open switch. When a spigot is pulled, the spigot switch sends a signal to the IntelliTec2 control to start the auger drive and refrigeration system. This signal moves the control to "Serve Mode", or if it already is in "Serve Mode", it resets the cycle count. After serving product, the IntelliTec continues a freezing cycle until the product reaches consistency.

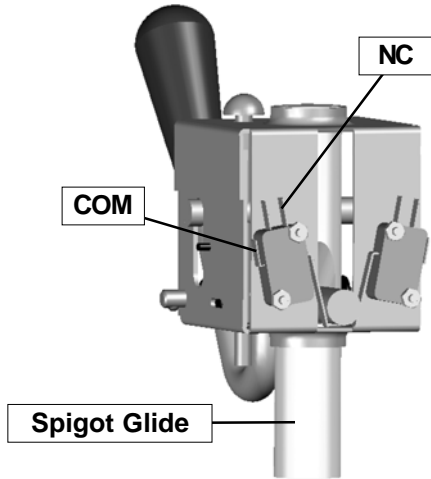

Figure 6-6 Spigot Cam Assembly (Center Spigot)

SPIGOT SWITCH TEST - ADJUSTMENT

NOTE

Adjustments to the spigot switch should be done after the product is at consistency in "Serve Mode" or when the machine is empty.

1. Open the spigot slowly and listen for a click when the spigot switch closes.
2. The clicking sound should be within the first 1/2" of the spigot glide movement (Refer to Figure 6-5). If the switch does not close, an adjustment may be necessary.

NOTE

The center spigot has two switches; one for each side. When testing the center spigot, there should be two audible clicks occurring almost simultaneously.

SPIGOT SWITCH TESTING - ELECTRICAL

1. Disconnect the switch from the circuit by unplugging the connectors.
2. Check resistance readings across the common (COM) and normally closed (NC) terminals. When the spigot is closed, the resistance should show an open. When the spigot is opened, the switch will close and the resistance should be 0 ohms.

SPIGOT SWITCH ADJUSTMENT

1. Turn the machine off by pressing the Main Power On/Off button.
2. Remove the header panel.
3. Loosen the bolts on the spigot switch.
4. Using a pencil, mark the spigot glide 1/4" from the spigot housing.
5. Adjust the switch to activate when the plastic glide reaches the mark.
6. Fully tighten the retaining bolts and remove mark from spigot glide.

SPIGOT SWITCH REPLACEMENT

1. Remove the header panel.



WARNING

Hazardous voltage

Make sure the machine is off when disassembling for servicing. The machine must be disconnected from electrical supply before removing any access panel. Failure to disconnect power before servicing could result in death or serious injury.

2. Remove the dispense rate adjuster knob located below the header panel. (Refer to Figure 6-6)
3. Remove the two Phillips head screws that attach the spigot cam assembly to the panel. Remove the assembly.
4. Disconnect the connector from the switch and remove the switch..
5. Install the replacement switch onto the handle assembly. Do not fully tighten the retaining screws at this time.

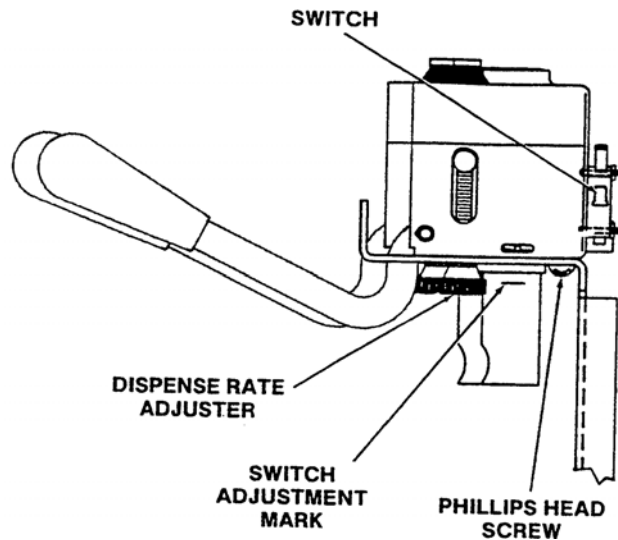

Figure 6-7 Spigot Switch Replacement

6. Using a pencil, mark the spigot glide 1/4" from the spigot housing. Adjust the switch to activate when the spigot handle moves the glide to the mark.
7. Fully tighten the retaining screws.
8. Attach the connector to the spigot switch.
9. Position the spigot handle assembly in the electrical box and fasten securely with the two Phillips head screws.
10. Replace the dispense rate adjuster knob and tighten.
11. Replace the header panel and secure with the two Phillips head screws.

when the temperature of the sensor equals the Cut In T value on the control, a freezing cycle will start.

When troubleshooting a sensor, refer to the wiring diagram and remove the wires from the control board. Measure the resistance of the sensor and compare it with the table below. If the resistance is not within this range, replace it.

6.8 TEMPERATURE CONTROL SENSOR

The temperature control sensor is a thermistor used to sense the temperature of the suction line. As the suction line temperature increases, the internal resistance of the thermistor will decrease. Refer to Figure 6-8 for the relationship between sensor resistance and temperature. The IntelliTec control board monitors this value. In "Serve Mode",

°F	Resistance	°F	Resistance
-22	176950	40	26100
-20	165200	42	24725
-18	154300	44	23400
-16	144200	46	22175
-14	134825	48	21000
-12	126125	50	19900
-10	118050	52	18875
-8	110550	54	17900
-6	103550	56	17000
-4	97075	58	16125
-2	91025	60	15325
0	85400	62	14550
2	80150	64	13825
4	75275	66	13150
6	70725	68	12500
8	66475	70	11875
10	62500	72	11300
12	58800	74	10750
14	55325	76	10250
16	52100	78	9750
18	49075	80	9300
20	46250	82	8850
22	43600	84	8450
24	41125	86	8050
26	38800	88	7675
28	36625	90	7325
30	34575	92	7000
32	32675	94	6675
34	30875	96	6375
36	29175	98	6100
38	27600	100	5825

Figure 6-8 Temperature Sensor Resistance (10K Ohms)

SECTION 7 TROUBLESHOOTING

7.1 ERROR CODES

When the machine experiences a problem, one of the following error codes will be displayed on the control panel. Each error code directs you to the system location of the malfunction.

ERROR CODE	MALFUNCTION
2	High Torque
3	Run Time
4	Clean
5	Freezing Cylinder Sensor
6	Hopper Sensor (single hopper machines)
7	Drive Motor
8	Cab Sensor
9	High Pressure Cutout
10	Ambient Sensor
11	Prime
12	Left Storage Sensor
13	Right Storage Sensor

To return the machine to normal operation, any error causing condition must be corrected and the freezing cylinder must be turned off and on again using the On/Off Left or On/Off Right button.

7.2 TROUBLESHOOTING

ERROR CODE 2 - HIGH TORQUE

If the control panel displays a High Torque Error (E2), the drive motor is running at a high load for 10 or more seconds. Very low and/or fluctuating supply voltages typically cause this error. The error can also be caused by faulty motor or starting components which could produce a high amp draw.

ERROR CODE 3 - RUN TIME

The Run Time Error (E3) occurs when the compressor runs continuously for an extended period. This error could happen if the cutout parameter is not attained. This error is generally caused by very low mix levels in the hopper or from product breakdown. Another common cause results from a restriction preventing mix from entering the freezing cylinder. Check the mix on the affected freezing cylinder. If the level mix is low, add mix. If there is a possibility that the mix is broken down, clean and sanitize the machine and replace the mix with fresh product.

Ice crystals in the hopper can clog the mix inlet regulator and prevent mix from entering the freezing cylinder. Thoroughly thaw mix per manufacturer's recommendations. To check for ice crystals, pour a small amount of product from the hopper through a clean and sanitized sieve or strainer. If ice crystals are in the mix, check the temperature of the walk-in cooler where the mix is stored or the temperature of the machine's hopper. If the hopper is below 34°F (1°C), adjust the temperature by raising the Storage Cutout value in the Storage Settings menu.

The Run Time Error may also occur if airflow within the machine has reduced or stopped. Check the sides and top of the machine for anything that would restrict airflow. Check the condenser filter and clean if necessary. Check the evaporator for frost that could restrict airflow.

The compressor will run continuously if a solenoid valve fails to open. This could be due to loose wiring, magnetic coil failure, a stuck valve or a faulty control board.

After the cause of the problem is found and remedied press the On/Off button for the cylinder to turn it off then back on.

ERROR CODE 4 - CLEAN

If the machine is left in the Clean Mode for more than 20 minutes, the control panel will display a Clean Error (04). This condition does not reflect a problem with the machine itself. The Clean Error has been programmed into the controller as a safeguard to protect the machine from potential damage caused by the machine being accidentally left in "Clean Mode". To clear the Clean Error, press the On/Off button for the cylinder to turn it off then back on.

ERROR CODE 5 - FREEZING CYLINDER SENSOR

The Freezing Cylinder Sensor Error (E5) indicates a failure of the barrel sensor or if the sensor is out of range. If the control panel displays an E5, press the On/Off button for the cylinder to turn it off then back on. If the control panel still displays the error code, refer to the machine's wiring diagram and the Temperature Sensor Chart (Figure 4-1). Check each lead of the sensor to ground for continuity. If continuity is found, replace the sensor. To check the resistance of the sensor, place a thermocouple on the suction line at the exit of the freezing cylinder. Compare temperature and sensor resistance with the table as reference. If measured value does not coincide with a value on the table (± 500 ohms), replace the sensor.

NOTE

When the machine encounters a Freezing Cylinder Sensor Error, the machine will continue to run using preset timers. This mode will allow the operator to continue serving product until the machine can be serviced.

°F	Resistance	°F	Resistance
-22	176950	40	26100
-20	165200	42	24725
-18	154300	44	23400
-16	144200	46	22175
-14	134825	48	21000
-12	126125	50	19900
-10	118050	52	18875
-8	110550	54	17900
-6	103550	56	17000
-4	97075	58	16125
-2	91025	60	15325
0	85400	62	14550
2	80150	64	13825
4	75275	66	13150
6	70725	68	12500
8	66475	70	11875
10	62500	72	11300
12	58800	74	10750
14	55325	76	10250
16	52100	78	9750
18	49075	80	9300
20	46250	82	8850
22	43600	84	8450
24	41125	86	8050
26	38800	88	7675
28	36625	90	7325
30	34575	92	7000
32	32675	94	6675
34	30875	96	6375
36	29175	98	6100
38	27600	100	5825

Figure 7-1 Temperature Sensor Resistance (10K Ohms)

ERROR CODE 6 - HOPPER SENSOR

The Hopper Sensor Error (E6) will not occur on the O231.

ERROR CODE 7 - DRIVE MOTOR

If the control panel displays a Drive Motor Error (E7), the control does not sense the drive motor. Press the On/Off button for the cylinder to turn it off then back on. If the error returns, use the machine's wiring diagram and check connections at the IntelliTec control and at the motor. An E7 may also be the result of a faulty drive motor contactor.

ERROR CODE 8 - CAB SENSOR

A Cab Sensor Error (E8) will not occur on the O231.

ERROR CODE 9 - HIGH PRESSURE CUTOUT

High Pressure Cutout Errors (E9) are usually caused by a dirty or inefficient condenser. If the control panel displays an E9, press the On/Off button for the cylinder to turn it off. Wait for 8-10 minutes for the machine pressures stabilize and an the internal timer to expire then press the On/Off button for the cylinder to turn it back on.

In air cooled condenser models, check the air filter to make sure it is clean. Replace or clean the filter as required. Check for proper air clearance around the machine. Refer to the machine's Owner's Manual for clearances. Check the condenser for blockage, and be sure condenser fan is functioning.

On water cooled condenser models, check for proper water flow through the condenser coil.

After the cause of the error is determined and corrected, press the On/Off button for the cylinder to turn it off then back on.

ERROR CODE 10 - AMBIENT SENSOR

The Ambient Temperature Sensor Error (E10) indicates a failure of the condenser air inlet temperature sensor or if the sensor is out of range. If the control panel displays an E10, press the On/Off button for the cylinder to turn it off then back on. If the control panel still displays the error condition code, refer to the machine's wiring diagram and the Temperature Sensor Chart (Figure 4-1). Check each lead of the sensor to ground for continuity. If continuity is found, replace the sensor. To check the resistance of the sensor, place a thermocouple on the suction line at the exit of the freezing cylinder. Compare temperature and sensor resistance with the table as reference. If measured value does not coincide with a value on the table (± 400 ohms), replace the sensor.

ERROR CODE 11 - PRIME

The Prime Error (E11) will not occur on the O231.

ERROR CODE 12 - LEFT HOPPER SENSOR

The Left Hopper Sensor Error (E12) indicates a failure of the hopper sensor or if the sensor is out of range. If the control panel displays an E12, press the On/Off button for the cylinder to turn it off then back on. If the control panel still displays the error condition code, refer to the machine's wiring diagram and the Temperature Sensor Chart (Figure 4-1). Check each lead of the sensor to ground for continuity. If continuity is found, replace the sensor. To check the resistance of the sensor, place a thermocouple on the suction line at the exit of the freezing cylinder. Compare temperature and sensor resistance with the table as reference. If measured value does not coincide with a value on the table (± 400 ohms), replace the sensor.

ERROR CODE 13 - RIGHT HOPPER SENSOR

The Right Hopper Sensor Error (E13) indicates a failure of the hopper sensor or if the sensor is out of range. If the control panel displays an E13, press the On/Off button for the cylinder to turn it off then back on. If the control panel still displays the error condition code, refer to the machine's wiring diagram and the Temperature Sensor Chart (Figure 4-1). Check each lead of the sensor to ground for continuity. If continuity is found, replace the sensor. To check the resistance of the sensor, place a thermocouple on the suction line at the exit of the freezing cylinder. Compare temperature and sensor resistance with the table as reference. If measured value does not coincide with a value on the table (± 400 ohms), replace the sensor.

7.3 TROUBLESHOOTING - MACHINE

PROBLEM	POSSIBLE CAUSE	REMEDY
Machine does not run.	<ol style="list-style-type: none"> 1 Power to machine is off. 2 Blown fuse or tripped circuit. 3 Freeze-up (auger will not turn). 4 High pressure cut-out tripped. 5 Front door not in place. 	<ol style="list-style-type: none"> 1 Supply power to machine. 2 Replace or reset. 3 Turn off machine for 15 minutes, then restart. 4 Wait until automatic reset for machine to start. 5 Assemble front door in place.
Machine will not shut off.	<ol style="list-style-type: none"> 1 Drive belt failure. 2 Consistency temperature setting is too firm. 3 Refrigeration problem. 	<ol style="list-style-type: none"> 1 Replace drive belt. 2 Turn Consistency Adjustment knob counter-clockwise. 3 Check system. (See Section 5)
Product is too firm.	<ol style="list-style-type: none"> 1 CutOut setting is too high. 	<ol style="list-style-type: none"> 1 Adjust the CutOut Consistency (See Section 3)
Product is too soft.	<ol style="list-style-type: none"> 1 No vent space for free flow of cooling air. 2 Air temperature entering condenser is above 100°F. 3 Condenser is dirty. 4 CutOut setting is too low. 5 Stabilizers in mix are broken down. 6 Auger is assembled incorrectly. 7 Product break down. 8 Refrigeration problem. 	<ol style="list-style-type: none"> 1 A minimum of 3" of vent space required. (See Section 2) 2 Change location or direct hot air away from machine. 3 Clean the condenser. (See Section 3) 4 Adjust the CutOut Consistency (See Section 3) 5 Remove mix, clean, sanitize and freeze down with fresh mix. 6 Remove mix, clean, reassemble, sanitize and freeze down. 7 Drain, clean and sanitize machine. Fill with fresh mix. 8 Check system. (See Section 5)
Product does not dispense.	<ol style="list-style-type: none"> 1 No mix in hopper. 2 Drive motor overload tripped. 3 Drive belt failure. 4 Freeze-up (Auger will not turn). 	<ol style="list-style-type: none"> 1 Fill hopper with mix. 2 Wait for automatic reset. 3 Replace drive belt. 4 Turn off cylinder, wait for 15 minutes, then restart.
Drive belt slipping or squealing.	<ol style="list-style-type: none"> 1 Worn drive belt. 2 Freeze-up (Auger will not turn). 3 Not tensioned properly 	<ol style="list-style-type: none"> 1 Replace drive belt. 2 Turn off cylinder, wait for 15 minutes, then restart. 3 Adjust belt tension
Rear auger seal leaks.	<ol style="list-style-type: none"> 1 Outside surface of rear auger seal is lubricated. 2 Rear seal missing or damaged. 3 Seal o-ring missing, damaged or installed incorrectly. 4 Worn or scratched auger shaft. 	<ol style="list-style-type: none"> 1 Clean lubricant from outside of rear seal, lubricate inside of seal and reinstall. 2 Check or replace. 3 Check or replace. 4 Replace auger shaft.
Front door leaks.	<ol style="list-style-type: none"> 1 Front door knobs are loose. 2 Spigot parts are not lubricated. 3 Chipped or worn spigot o-rings. 4 O-rings or spigot installed wrong. 5 Inner spigot hole in front door nicked or scratched. 	<ol style="list-style-type: none"> 1 Tighten knobs. 2 See Section 3. 3 Replace o-rings. 4 Remove spigot and check o-ring. 5 Replace front door.

SECTION 8 REPLACEMENT PARTS

8.1 DECALS AND LUBRICATION

Part	Description	Quantity
208135	Brush - 4" X 8" X 16" (Barrel)	1
208380	Brush - 1/4" X 3" X 14"	1
208401	Brush - 1" X 3" X 10"	1
208467	Brush - 3/8" X 1" X 5"	1
236059	Card - Cleaning Instruction	1
244138	Caster - Non-Locking (4") (Each)	2
244139	Caster - Locking (4") (Each)	2
324065	Decal - Water Inlet	2
324103	Decal - Caution Rotating Shaft	1
324105	Decal - Caution Electrical Shock	1
324106	Decal - Caution Electrical Wiring Materials	1
324107	Decal - Caution Hazardous Moving Parts	1
324125	Decal - Danger Electric Shock Hazard	1
324141	Decal - Caution Rotating Blades	1
324200	Decal - High Pressure Cut-Out	1
324208	Decal - Attention Refrigerant Leak Check	1
324509	Decal - Cleaning Instructions	1
324566	Decal - Wired According To	1
324584	Decal - Adequate Ventilation 3"	1
324594	Decal - Attention Heat Sensitive	4
324686	Decal - Danger Automatic Start	1
324728	Decal - Contactor Identification	1
324803	Decal - Domed Stoelting Logo (Large) (Header Panel)	1
324888	Decal - Fan Motor Reset	1
324896	Decal - Contactor Identification	1
324901	Decal - Transformer Switch	1
368448	Filter - Air (Condenser)	1
508048	Lubricant - Spline (2 oz Squeeze Tube)	1
508135	Petrol Gel - 4 oz Tube	1
513645	Manual - Owner's	1
1159501	O-Ring & Bushing Kit	-

8.2 AUGER SHAFT AND FACEPLATE PARTS

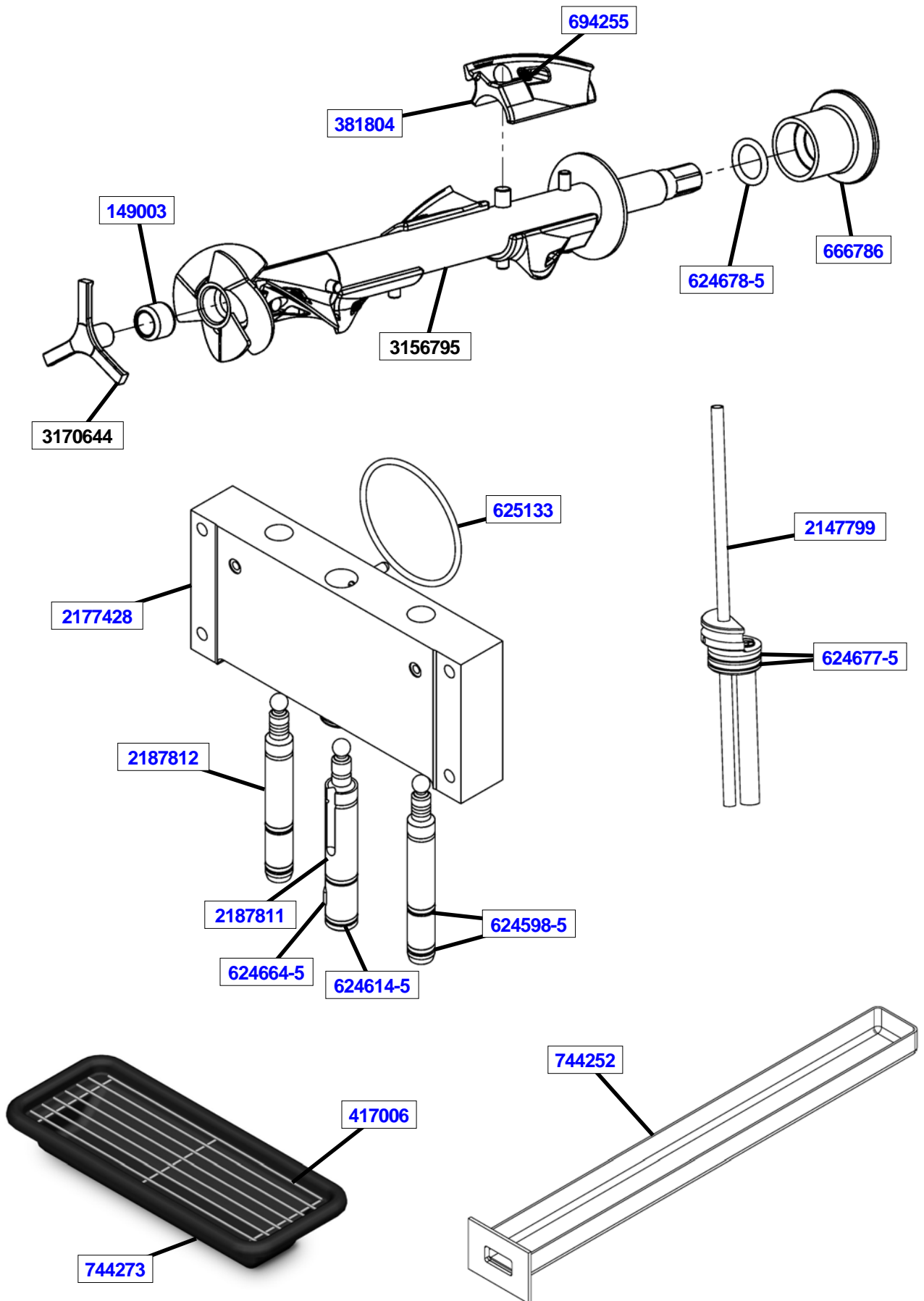

8.2 AUGER SHAFT AND FACEPLATE PARTS (CONTINUED)

Part	Description	Quantity
149003	Bushing - Front Auger Support	2
232734	Cap - Rosette - Teardrop	3
314477	Cover - Hopper	2
381804	Auger Flight	10
417006	Grid - Drip Tray (Metal)	1
482019	Knob - Front Door (Black)	4
624598-5	O-Ring - Outside Spigot - Black (5 Pack)	4
624614-5	O-Ring - Top & Bottom Center Spigot - Black (5 Pack)	2
624664-5	O-Ring - Middle Center Spigot - Black (5 Pack)	1
624677-5	O-Ring - Mix Inlet - Black (5 Pack)	4
624678-5	O-Ring - Rear Seal - Black (5 Pack)	2
625133	O-Ring - Front Door - Red	2
666786	Seal - Rear Auger - Black	2
694255	Spring - Auger Flight	5
744252	Tray - Drain (Black Plastic)	1
744273	Tray - Drip	1
2147799	Mix Inlet Assembly - 3/16" Hole - Extended Length (2LA)	2
2177428	Door w/Pins	1
2187811	Spigot Body - Center	1
2187812	Spigot Body - Outer	2
3156795	Auger Shaft	2
3170644	Support - Front Auger	2

8.3 SPIGOT ASSEMBLY

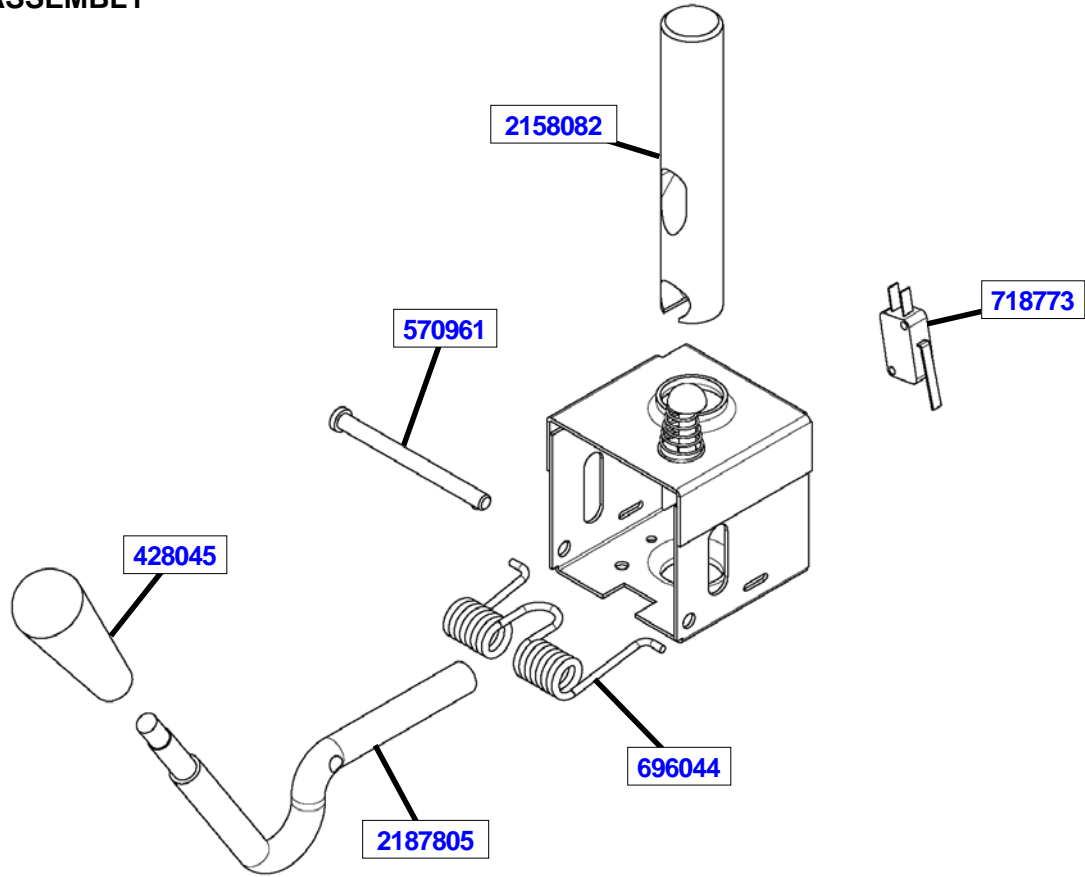

Part	Description	Quantity
428045	Knob - Spigot Handle (Black)	3
570961	Pin - Cotterless Clevis (Spigot Handle)	3
696044	Spring - Torsion (Spigot Handle)	3
718773	Switch - Limit (Spigot)	4
2158082	Glide - Spigot Socket	3
2187805	Handle - Spigot (Handle Only)	3

8.4 PANELS AND SCREWS

Part	Description	Quantity
647899	Screw - Panel (Side & Front)	-
647900	Screw - Panel (Rear)	-
2202040	Panel - Rear (Air Cooled)	1
2202041	Panel - Left Hand Side (Air Cooled)	1
2202042	Panel - Right Hand Side (Air Cooled)	1
2202043	Panel - Header	1
2202045	Panel - Upper Front	1
2202047	Panel - Drip Tray Support	1
2202089	Panel - Front Lower (Air Cooled)	1
2202255	Panel - Rear (Water Cooled)	1
2202256	Panel - Left Hand Side (Water Cooled)	1
2202257	Panel - Right Hand Side (Water Cooled)	1
2202259	Panel - Front Lower (Water Cooled)	1

8.5 ELECTRICAL PANELS

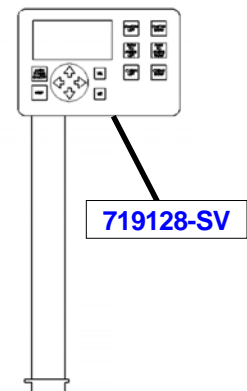
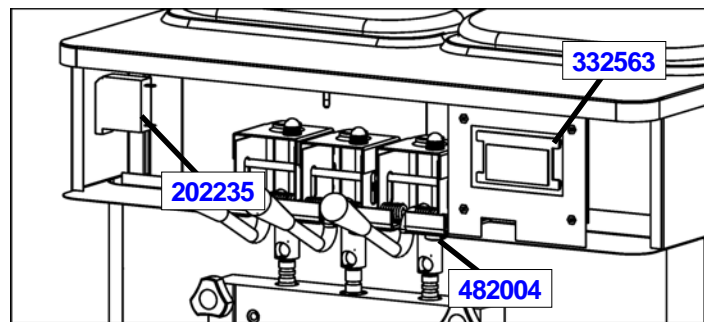
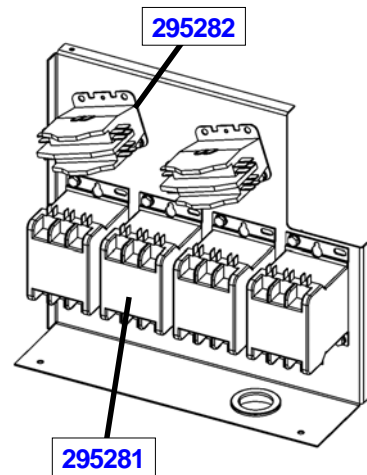
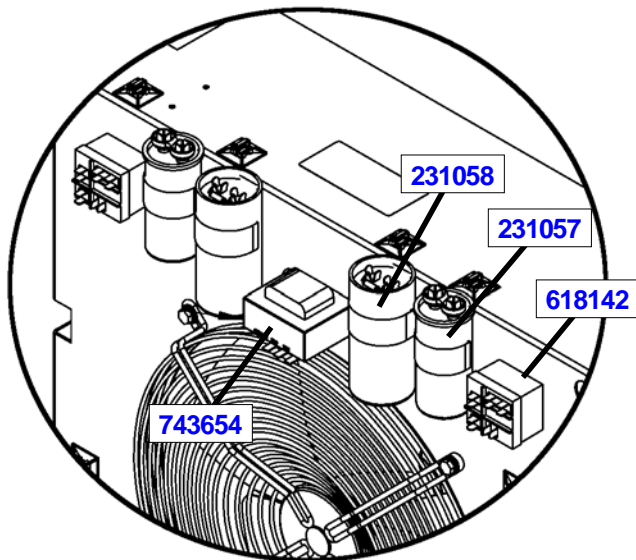

Part	Description	Quantity
202235	Circuit Breaker	1
229148	Cable - IntelliTec2	1
230654	Capacitor (Fan Motor)	1
231057	Capacitor - Run (#282018 Compressor)	2
231058	Capacitor - Start (#282018 Compressor)	2
295281	Contactor (Compressor / Drive)	4
295282	Contactor (IntelliTec2 Board)	2
332563	Board - Display Module	1
482004	Knob - Spigot Adjustment	3
618142	Relay (#282018 Compressor)	2
718776	Switch - Door Interlock	1
719128-SV	Switch - Membrane Strip (Touchpad & Ribbon)	1
743654	Transformer - Booster	1

8.6 INTERNAL COMPONENTS

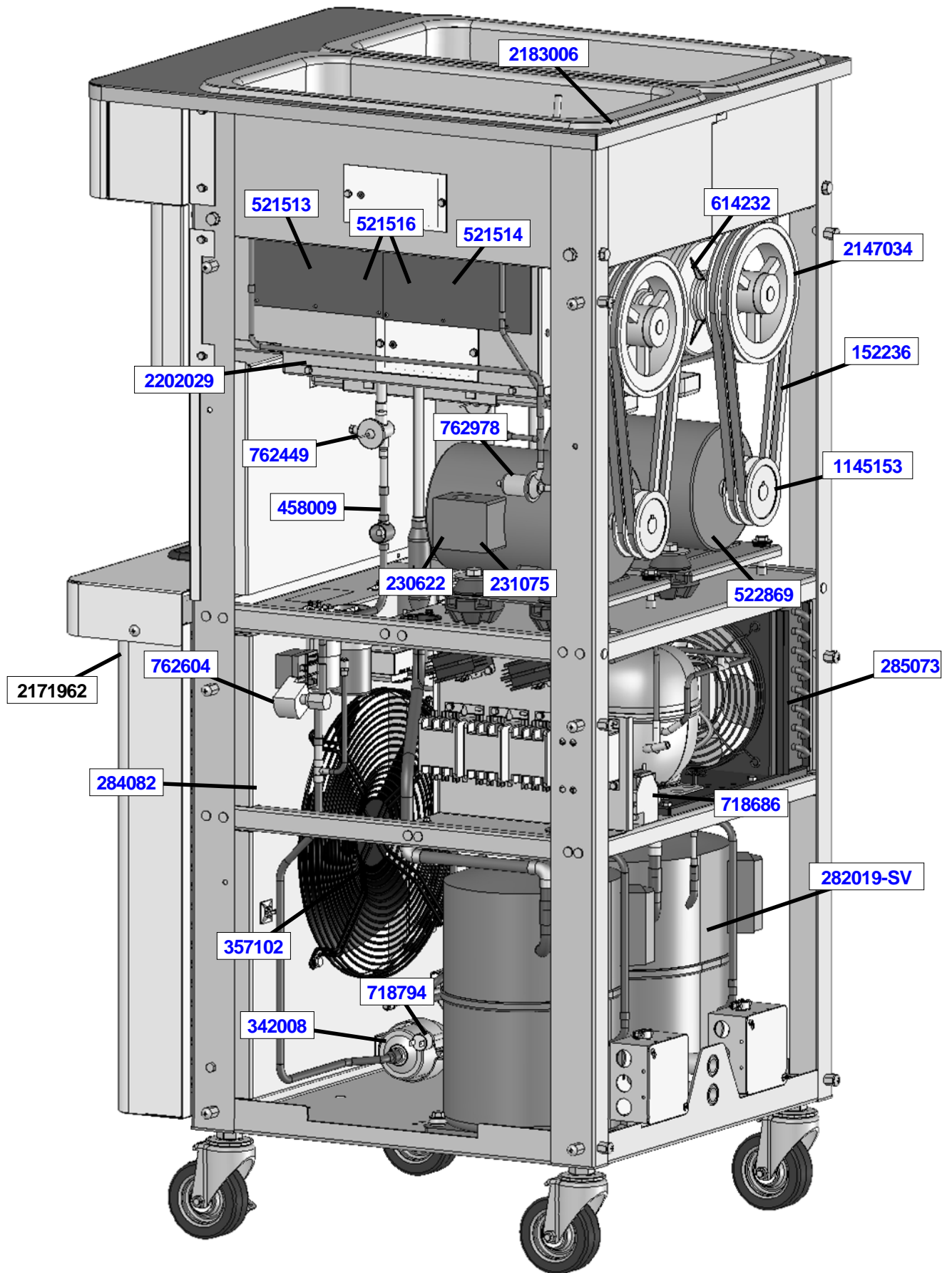

8.6 INTERNAL COMPONENTS (CONTINUED)

Part	Description	Quantity
DR-0010	Drier - Filter (1/4" OD) (Cap Tube)	1
152236	Belt - Gripnotch (AX36) (Each)	4
230622	Capacitor - Start (#522856 Motor)	2
231075	Capacitor - Run (#522856 Motor)	2
282018-SV	Compressor - Copeland 1 PH (No Capacitors)	1
282019-SV	Compressor - Copeland 3 PH	1
284082	Condenser (Air-Cooled)	1
284104	Condenser (Water-Cooled)	1
285073	Condensing Unit (Hoppers)	1
342008	Drier (Liquid Line)	2
357102	Motor - Fan (Air-Cooled Condenser) (Includes Blade & Guard)	1
458009	Sight Glass	2
521513	Board - Program (IntelliTec2)	1
521514	Board - Relay (IntelliTec2)	1
521516	Board - Program / Relay (IntelliTec2)	1
522856	Motor - Drive (1 PH)	2
522869	Motor - Drive (3 PH)	2
614232	Speed Reducer	2
718539	Switch - Toggle (208/230V)	1
718686	Switch - Pressure (High Pressure Cutout) (Hopper) (1)	1
718794	Switch - High Pressure (Barrels) (2)	2
762449	Valve - Expansion	2
762490	Valve - Expansion (YG2 Models)	2
762604	Valve - Solenoid (Liquid Line)	2
762978	Valve - EPR	1
763181	Valve - Water	2
1145153	Pulley - Drive Motor	2
2147034	Pulley - Speed Reducer	2
2171962	Sensor Probe Kit	1
2183006	Probe Assembly - Hopper Liquid Level	2
2202029	Evaporator / Hopper Assembly	1

STACMASTER
 100 W. WASHINGTON U.S.A. 5342
 ELECTRICAL WIRING DIAGRAM
 MODEL: 2231-3092
 DIAGRAM NO.: 2202653-WD

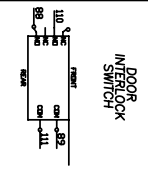
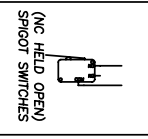
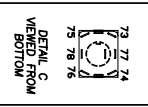
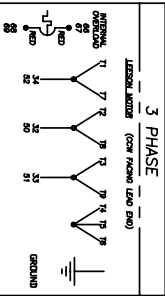
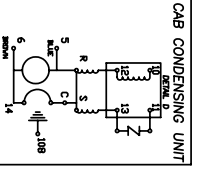

2202653-WD

CAUTION
 DISCONNECT POWER SUPPLY
 BEFORE SERVICING

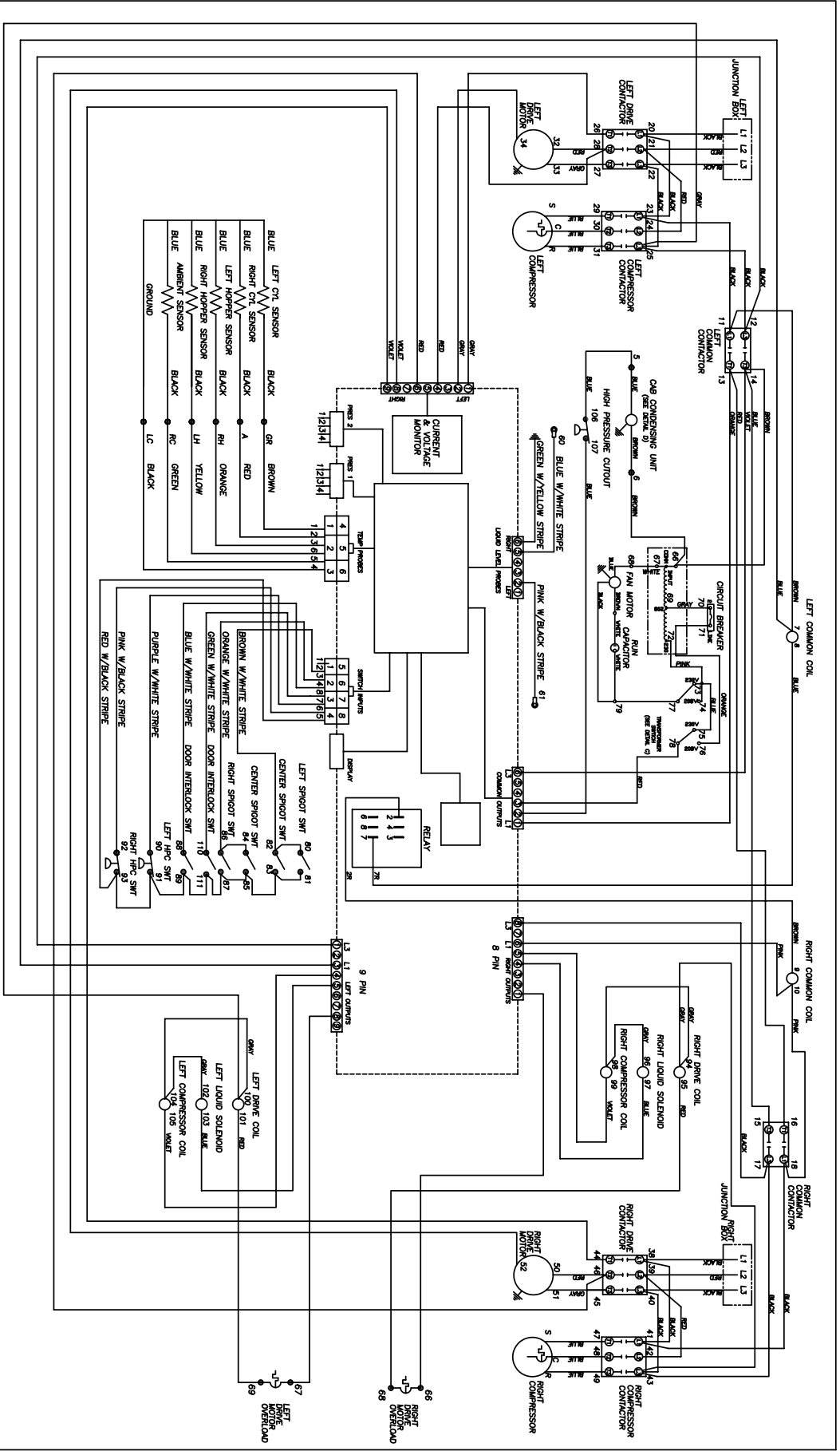

STANLEY
 100 W. WASHINGTON, U.S.A. 5342
 ELECTRICAL WIRING DIAGRAM
 MODEL: 2231-1092
 DIAGRAM NO.: 2202654-WD

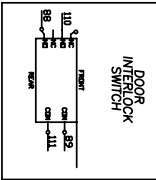
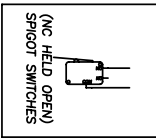
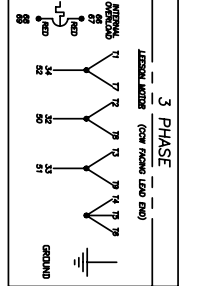
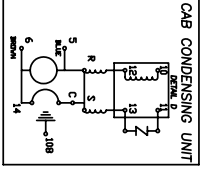
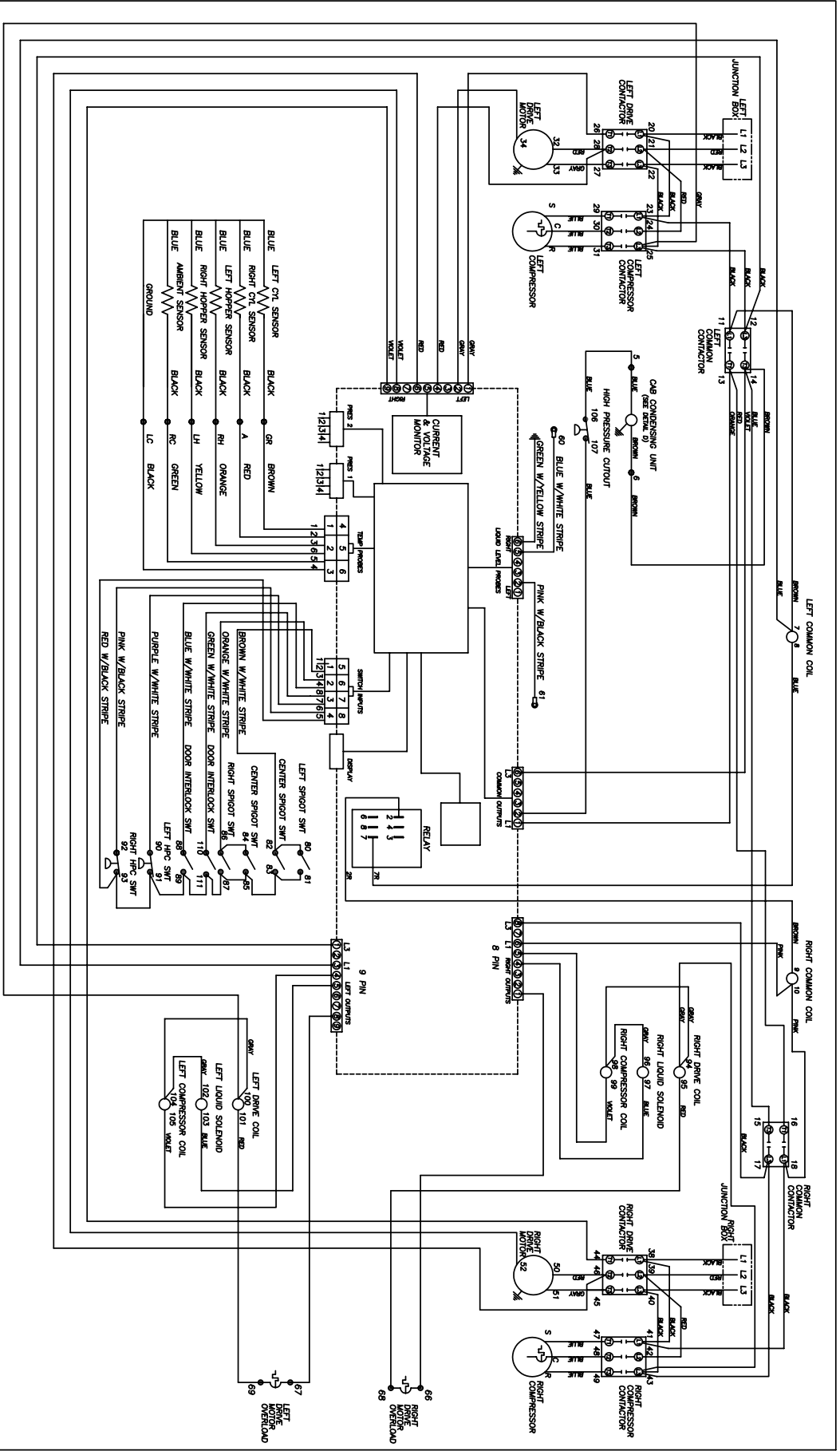

2202654-WD

CAUTION
 DISCONNECT POWER SUPPLY
 BEFORE SERVICING



**DOMESTIC WARRANTY
(Including Mexico)
SOFT SERVE / SHAKE EQUIPMENT**

1. **Scope:**
PW Stoelting, L.L.C. (“Stoelting”) warrants to the first user (the “Buyer”) that the freezing cylinders, hoppers, compressors, drive motors, speed reducers, and augers of Stoelting soft serve / shake equipment will be free from defects in materials and workmanship under normal use and proper maintenance appearing within five (5) years, and that all other components of such equipment manufactured by Stoelting will be free from defects in material and workmanship under normal use and proper maintenance appearing within twelve (12) months after the date that such equipment is originally installed.

2. **Disclaimer of Other Warranties:**

THIS WARRANTY IS EXCLUSIVE; AND STOELTING HEREBY DISCLAIMS ANY IMPLIED WARRANTY OF MERCHANTABILITY OR FITNESS FOR PARTICULAR PURPOSE.

3. **Remedies:**
Stoelting’s sole obligations, and Buyer’s sole remedies, for any breach of this warranty shall be the repair or (at Stoelting’s option) replacement of the affected component at Stoelting’s plant in Kiel, Wisconsin, or (again, at Stoelting’s option) refund of the purchase price of the affected equipment, and, during the first twelve (12) months of the warranty period, deinstallation/reinstallation of the affected component from/into the equipment. Those obligations/remedies are subject to the conditions that Buyer (a) signs and returns to Stoelting, upon installation, the Start-Up and Training Checklist for the affected equipment, (b) gives Stoelting prompt written notice of any claimed breach of warranty within the applicable warranty period, and (c) delivers the affected equipment to Stoelting or its designated service location, in its original packaging/crating, also within that period. Buyer shall bear the cost and risk of shipping to and from Stoelting’s plant or designated service location.

4. **Exclusions and Limitations:**
This warranty does not extend to parts, sometimes called “wear parts”, which are generally expected to deteriorate and to require replacement as equipment is used, including as examples but not intended to be limited to o-rings, auger flights, auger seals, auger support bushings, and drive belts. All such parts are sold

AS IS.

Further, Stoelting shall not be responsible to provide any remedy under this warranty with respect to any component that fails by reason of negligence, abnormal use, misuse or abuse, use with parts or equipment not manufactured or supplied by Stoelting, or damage in transit.

THE REMEDIES SET FORTH IN THIS WARRANTY SHALL BE THE SOLE LIABILITY STOELTING AND THE EXCLUSIVE REMEDY OF BUYER WITH RESPECT TO EQUIPMENT SUPPLIED BY STOELTING; AND IN NO EVENT SHALL STOELTING BE LIABLE FOR ANY INCIDENTAL OR CONSEQUENTIAL DAMAGES, WHETHER FOR BREACH OF WARRANTY OR OTHER CONTRACT BREACH, NEGLIGENCE OR OTHER TORT, OR ON ANY STRICT LIABILITY THEORY.