



CC Model Machines
OPERATORS MANUAL

Manual No. [513642](#)

Rev.6

This manual provides basic information about the machine. Instructions and suggestions are given covering its operation and care. This manual follows the guidance set forth in the following industry standards: ANSI Z535.6, ASTM F760-93, ASTM F1827-13, FDA Food Code.

The illustrations and specifications in this manual are not binding in detail. We reserve the right to make changes to the machine without notice, and without incurring any obligation to modify or provide new parts for machines built prior to date of change.

DO NOT ATTEMPT to operate the machine until instructions and safety precautions in this manual are read completely and are thoroughly understood. If problems develop or questions arise in connection with installation, operation, or servicing of the machine, contact Stoelting White Glove Service.

For warranty information, visit stoeltingfoodservice.com



stoeltingfoodservice.com

Stoelting Foodservice Equipment
502 Highway 67
Kiel, WI 53042-1600
U.S.A.

White Glove Service Network
Phone: 888.319.9549

© 2021 Stoelting

A Few Words About Safety

Safety Information

Read and understand the entire manual before operating or maintaining Stoelting equipment.

This manual provides the operator with information for the safe operation and maintenance of Stoelting equipment. As with any machine, there are hazards associated with their operation. For this reason safety is emphasized throughout the manual. To highlight specific safety information, the following safety definitions are provided to assist the reader.

The purpose of safety symbols is to attract your attention to possible dangers. The safety symbols, and their explanations, deserve your careful attention and understanding. The safety warnings do not by themselves eliminate any danger. The instructions or warnings they give are not substitutes for proper accident prevention measures.

If you need to replace a part, use genuine Stoelting parts with the correct part number or an equivalent part. We strongly recommend that you do not use replacement parts of inferior quality.



Safety Alert Symbol:

This symbol Indicates danger, warning or caution. Attention is required in order to avoid serious personal injury. The message that follows the symbol contains important information about safety.

Signal Word:

Signal words are distinctive words used throughout this manual that alert the reader to the existence and relative degree of a hazard.



The signal word “WARNING” indicates a potentially hazardous situation, which, if not avoided, may result in death or serious injury.



The signal word “CAUTION” indicates a potentially hazardous situation, which, if not avoided, may result in minor or moderate injury.

NOTICE

The signal word “*NOTICE*” indicates information relating to equipment/property damage. The information is not hazard-related.

NOTE

The signal word “NOTE” indicates additional information relating to the subject, usually a hint or tip, that is not hazard-related and does not involve equipment/property damage.

Table of Contents

Section	Description	Page
Section 1 - Description and Specifications		1
1.1	Description.....	1
1.2	Machine Specifications	2
1.3	Remote Condensing Units Specifications	3
1.4	International Specifications	5
Section 2 - Installation Instructions		7
2.1	Safety Precautions.....	7
2.2	Receiving the Custard Machine	7
2.3	Machine Installation.....	7
Section 3 - Initial Set-Up and Operation		13
3.1	Operator's Safety Precautions	13
3.2	Operating Controls And Indicators	13
3.3	Sanitizing.....	15
3.4	Freeze Down And Operation.....	15
3.5	Hold Cycle	16
3.6	Production From Hold	17
3.7	Italian Ice Freeze Down And Operation.....	17
3.8	Removing Mix From Machine	18
3.9	Cleaning The Machine.....	18
3.10	Disassembly Of Machine Parts.....	19
3.11	Cleaning The Machine Parts.....	19
3.12	Assembly Of Machine.....	20
3.13	Routine Cleaning.....	21
3.14	Preventative Maintenance.....	21
3.15	Extended Storage	21
Section 4 - Troubleshooting		23
4.1	Error codes	23
4.2	Troubleshooting Error Codes	23
4.3	Troubleshooting Tables.....	25
Section 5 - Replacement Parts		27
5.1	Decals And Lubrication	27
5.2	Auger Shaft And Faceplate Parts	28
5.3	Hopper Parts	29

Section 1 - Description and Specifications

1.1 DESCRIPTION

The CC series machines are continuous flow custard machines. They are equipped with fully automatic controls to provide a uniform product and feature Quick-Freeze technology. This manual is designed to assist qualified service personnel and operators in the installation, operation and maintenance of the CC series frozen custard machines.

NOTE

Product breakdown could happen quicker if product is stored in the freezing cylinders in standby mode. After a batch is made, close the flow control and empty the contents of the freezing cylinder.



Figure 1-1 Model CC303

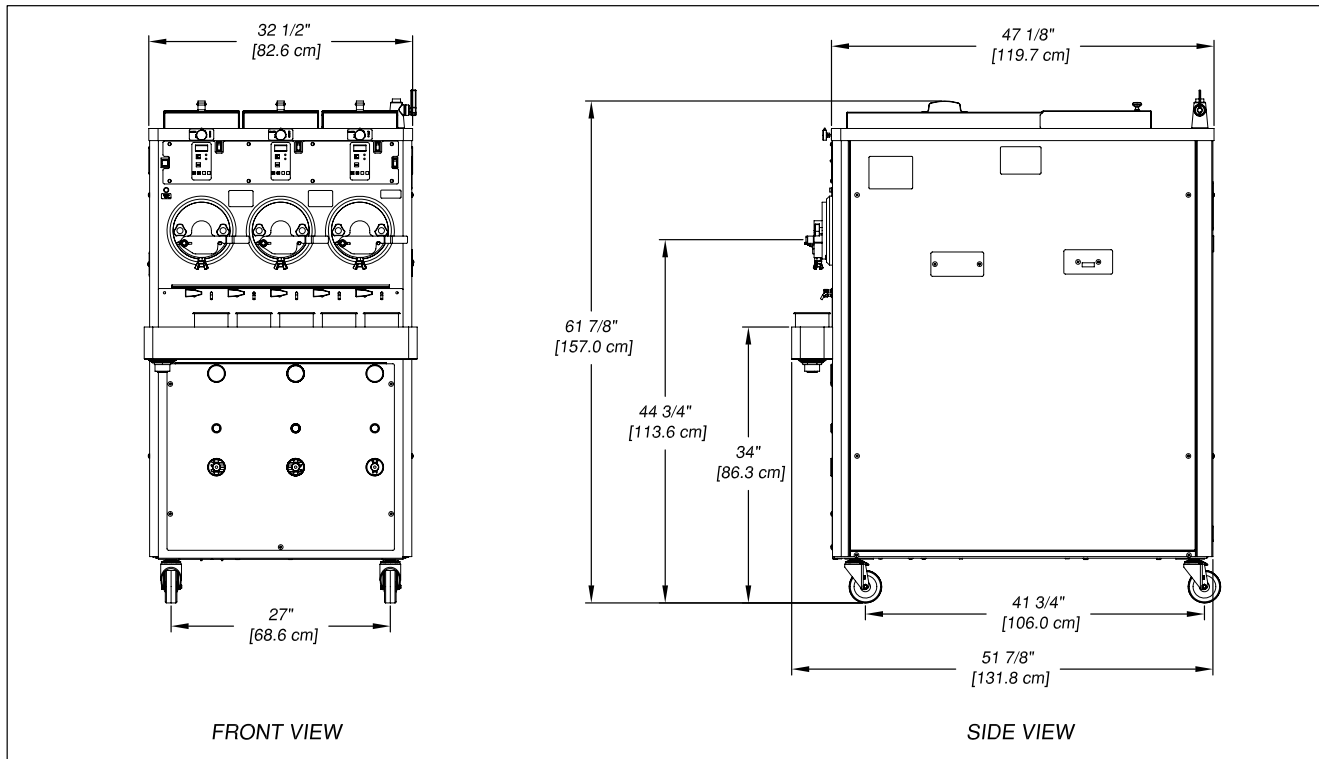

Figure 1-2 Model CC303 Dimensions

1.2 MACHINE SPECIFICATIONS

	CC202A Air Cooled Remote		CC202A Water Cooled	
Dimensions	Machine	with crate	Machine	with crate
width	25-1/2" (64,8 cm)	48" (121,9 cm)	25-1/2" (64,8 cm)	48" (121,9 cm)
height	61-7/8" (157,2 cm)	68" (172,7 cm)	61-7/8" (157,2 cm)	68" (172,7 cm)
depth	47-1/8" (119,7 cm)	60" (152,4 cm)	47-1/8" (119,7 cm)	60" (152,4 cm)
Weight	1030 lbs (467,2 kg)	1100 lbs (498,9 kg)	1030 lbs (467,2 kg)	1100 lbs (498,9 kg)
Electrical	1 Phase, 208-240 VAC, 60Hz	3 Phase, 208-240 VAC, 60Hz	1 Phase, 208-240 VAC, 60Hz	3 Phase, 208-240 VAC, 60Hz
circuit ampacity (per barrel)	12A minimum	9A minimum	28A minimum	21A minimum
overcurrent protection device (per barrel)	25A maximum	15A maximum	45A maximum	30A maximum
Hopper Condensing Unit	1 Phase, 115 VAC, 60Hz NEMA5-15P power cord provided			
Compressor	Freezing Cylinders - 9,800 Btu/hr Storage - 2,760 Btu/hr Compressor (R-134a)			
Drive Motor	Two - 3 hp			
Cooling	Air cooled units require one remote condensing unit (with compressor) per barrel. Condensing units for 60Hz machines ship from the factory with 20 lbs of refrigerant for up to a 50' line set. Add 1 lb of refrigerant for every 10' increase to the line set. Line set max 100'.		Water cooled units are self contained and require 1/2" N.P.T. water and drain fittings. Maximum water pressure of 130 psi. Minimum water flow rate of 3 GPM per barrel. Ideal EWT of 50°-70°F.	
Hopper Volume	Two - 8.8 gallon (33,32 liters)			

	CC303A Air Cooled Remote		CC303A Water Cooled	
Dimensions	Machine	with crate	Machine	with crate
width	32-1/2" (82,6 cm)	48" (121,9 cm)	32-1/2" (82,6 cm)	48" (121,9 cm)
height	61-7/8" (157,2 cm)	68" (172,7 cm)	61-7/8" (157,2 cm)	68" (172,7 cm)
depth	47-1/8" (119,7 cm)	60" (152,4 cm)	47-1/8" (119,7 cm)	60" (152,4 cm)
Weight	1095 lbs (496,6 kg)	1165 lbs (528,4 kg)	1095 lbs (496,6 kg)	1165 lbs (528,4 kg)
Electrical	1 Phase, 208-240 VAC, 60Hz	3 Phase, 208-240 VAC, 60Hz	1 Phase, 208-240 VAC, 60Hz	3 Phase, 208-240 VAC, 60Hz
circuit ampacity (per barrel)	12A minimum	9A minimum	28A minimum	21A minimum
overcurrent protection device (per barrel)	25A maximum	15A maximum	45A maximum	30A maximum
Hopper Condensing Unit	1 Phase, 115 VAC, 60Hz NEMA5-15P power cord provided			
Compressor	Freezing Cylinders - 9,800 Btu/hr Storage - 2,760 Btu/hr Compressor (R-134a)			
Drive Motor	Three - 3 hp			
Cooling	Air cooled units require one remote condensing unit (with compressor) per barrel. Condensing units for 60Hz machines ship from the factory with 20 lbs of refrigerant for up to a 50' line set. Add 1 lb of refrigerant for every 10' increase to the line set. Line set max 100'.		Water cooled units are self contained and require 1/2" N.P.T. water and drain fittings. Maximum water pressure of 130 psi. Minimum water flow rate of 3 GPM per barrel. Ideal EWT of 50°-70°F.	
Hopper Volume	Three - 8.8 gallon (33,32 liters)			

CC404A		
Dimensions	Machine	with crate
width	42-1/2" (108,0 cm)	50" (127,0 cm)
height	61-7/8" (157,2 cm)	67" (170,2 cm)
depth	47-1/8" (119,7 cm)	60" (152,4 cm)
Weight	1276 lbs (578,7 kg)	1346 lbs (610,5 kg)
Electrical	3 Phase, 208-240 VAC, 60Hz	
circuit ampacity (per barrel)	9A minimum	
overcurrent protection device (per barrel)	15A maximum	
Hopper Condensing Unit	1 Phase, 115 VAC, 60Hz NEMA5-15P power cord provided	
Compressor	Freezing Cylinders - 9,800 Btu/hr Storage - 2,760 Btu/hr Compressor (R-134a)	
Drive Motor	Four - 3 hp	
Cooling	Air cooled units require one remote condensing unit (with compressor) per barrel. Condensing units for 60Hz machines ship from the factory with 20 lbs of refrigerant for up to a 50' line set. Add 1 lb of refrigerant for every 10' increase to the line set. Line set max 100'.	
Hopper Volume	Four - 8.8 gallon (33,32 liters)	

1.3 REMOTE CONDENSING UNITS SPECIFICATIONS

Model numbers ending with "SPOR" or "SSIR" have piercing unions on the refrigeration lines. The line set and remote condensing unit need piercing unions to connect to the machine.

All other models are capped and require the refrigeration lines to be routed on site. The remote condensing units are also capped.

One remote condensing unit per barrel.

	Capped Refrigeration Lines 285112 (1 PH) & 285113 (3 PH)		Piercing Union Refrigeration Lines 285116 (1 PH) & 285117 (3 PH)	
Dimensions	Condenser		Condenser	
width	39-1/8" (99,4 cm)		39-1/8" (99,4 cm)	
height	19-3/4" (50,2 cm)		19-3/4" (50,2 cm)	
depth	28-1/4" (71,7 cm)		28-1/4" (71,7 cm)	
Weight	1 PH: 223 lbs (101,2 kg) / 3 PH: 228 lbs (103,4 kg)		1 PH: 223 lbs (101,2 kg) / 3 PH: 228 lbs (103,4 kg)	
Electrical	1 Phase, 208-230 VAC, 60Hz	3 Phase, 208-230 VAC, 60Hz	1 Phase, 208-230 VAC, 60Hz	3 Phase, 208-230 VAC, 60Hz
circuit ampacity	20A minimum	15A minimum	20A minimum	15A minimum
overcurrent protection device	25A maximum	20A maximum	25A maximum	20A maximum
Refrigerant	R-448A		R-448A	
Charge	20 lbs. (Charged at Factory)		20 lbs. (Charged at Factory)	
Refrigerated Line Sizes	Liquid Line - 3/8" Suction Line - 7/8"		Liquid Line - 3/8" Suction Line - 7/8"	

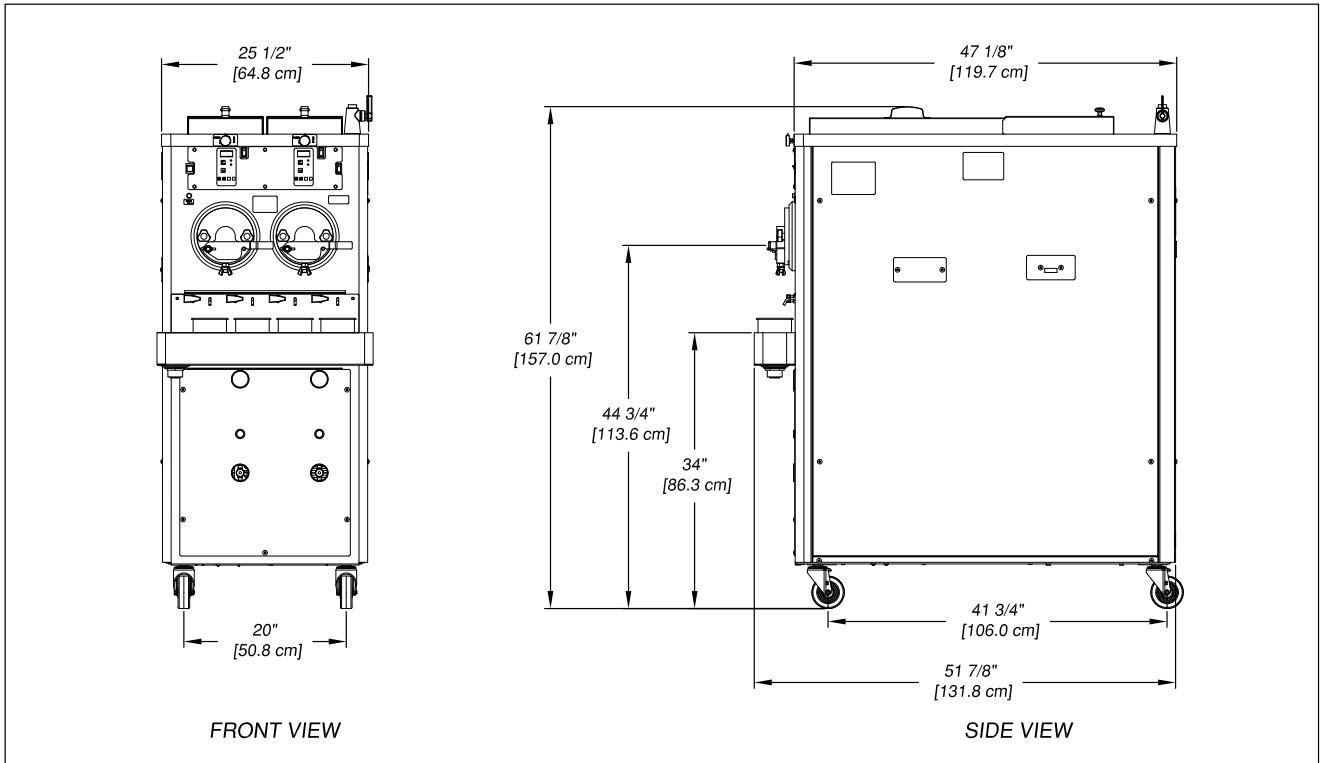

Figure 1-4 Model CC202 Dimensions

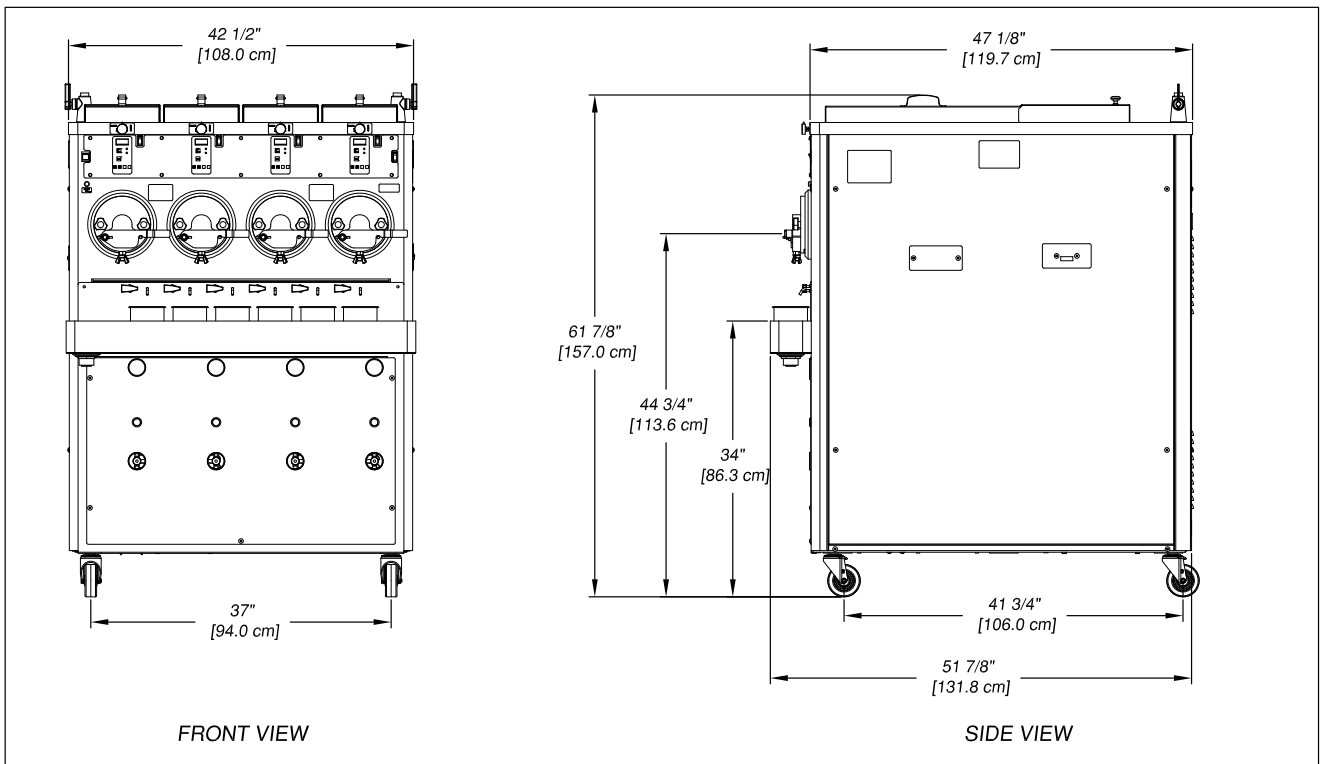

Figure 1-5 Model CC404 Dimensions

1.4 INTERNATIONAL SPECIFICATIONS

The table below shows the electrical requirements per barrel. Refer to the tables in Section 1.2 for the remainder of the specifications. There is a separate electrical circuit for each barrel.

	Air Cooled Remote		Water Cooled	
Electrical	1 Phase, 200-220 VAC, 50Hz	3 Phase, 380-415* VAC, 50Hz	1 Phase, 200-220 VAC, 50Hz	3 Phase, 380-415* VAC, 50Hz
circuit ampacity (per barrel)	12A minimum	6A minimum	32A minimum	12A minimum
overcurrent protection device (per barrel)	25A maximum	10A maximum	50A maximum	20A maximum
Hopper Condensing Unit	1 Phase, 200-240 VAC, 50Hz Requires a 15amp power cord			
Drive Motor	Three - 2 hp			

* The 380-415 VAC supply requires a neutral. The power supply must be 5 wire for proper operation.

	Remote Condensing Unit (1 per barrel)	
Electrical	1 Phase, 200-220 VAC, 50Hz	3 Phase, 380-415 VAC, 50Hz
circuit ampacity	20A minimum	15A minimum
overcurrent protection device	25A maximum	20A maximum
Refrigerant	R-448A	
Charge	20 lbs.	

* The remote condensing unit does not ship with refrigerant and requires a full charge of R-448A during installation.

Section 2 - Installation Instructions

2.1 SAFETY PRECAUTIONS

Do not attempt to operate the machine until the safety precautions and operating instructions in this manual are read completely and are thoroughly understood.

Take notice of all warning labels on the machine. The labels have been put there to help maintain a safe working environment. The labels have been designed to withstand washing and cleaning. All labels must remain legible for the life of the machine. Labels should be checked periodically to be sure they can be recognized as warning labels.

If danger, warning or caution labels are needed, indicate the part number, type of label, location of label, and quantity required along with your address and mail to:

STOELTING
ATTENTION: Customer Service
502 Hwy. 67
Kiel, Wisconsin 53042

2.2 RECEIVING THE CUSTARD MACHINE

1. Upon arrival, check the entire machine for any damage that may have occurred during transit. With the method of packaging used, the machine should arrive in excellent condition. The carrier is responsible for all damage in transit, whether visible or concealed. Do not pay the freight bill until the machine has been checked for damage. Have the carrier note any visible damage on the freight bill. If concealed damage or a shortage is found later, advise the carrier within 10 days and request inspection. The customer must place a claim for damages and/or shortages in shipment with the carrier. Stoelting cannot make any claims against the carrier.
2. Remove the top of the crate using a hammer or pry bar.
3. Remove the eight lag bolts from the machine using a 1/2" ratchet. Remove the front and rear crate walls.
4. Remove the four lag bolts located inside the left and right crate walls using 1/2" ratchet. Remove the left and right crate walls.
5. Remove the plastic wrapping on the machine. Remove the lower front and back panel on the machine.
6. Remove the four lag bolts located inside machine on the frame with a 9/16" ratchet. Remove the two lag bolts that hold the skid together with a 9/16" socket.
7. Put front and back panels on the machine.

2.3 MACHINE INSTALLATION

The following instructions are intended for a qualified electrician/refrigeration specialist. Do not attempt these procedures unless you are qualified.

A. RUNNING LINE SETS



Installation MUST be completed by a qualified electrician/refrigeration specialist

Incorrect installation may cause personal injury, severe damage to the machine and voids factory warranty.

NOTE

If the machine is water-cooled, proceed to "B. Running Electrical Connections".

Line sets are not supplied with the machine.

The lines sets can be installed prior to receiving the custard machine.

1. A remote air-cooled machine requires a remote condensing unit and line set for each freezing cylinder. The line sets must be 3/8" for the liquid line and 7/8" for the suction line. When running the line sets, each 10' of vertical rise, install a p-trap in the suction line. For every horizontal line set run, pitch the suction line towards the compressor to assist with oil returning back to the compressor.
2. After the line set is installed, perform a thorough leak test. Malfunctions of the equipment due to leaks in the line set are not covered by the Stoelting warranty.
3. Make sure the suction line is insulated with a minimum of 3/8" wall thickness or the wall thickness required by local code. In humid areas, use thicker insulation. In areas that are exposed to extreme temperatures, insulate the liquid line to prevent excessive sub cooling or heating of the liquid refrigerant. Fasten all lines securely along ceilings, walls and roofs. Avoid creating any type of kink in the lines. The Stoelting warranty does not cover malfunctions or capacity issues with equipment caused by kinks in the line sets.

4. Use good piping practices when installing line sets. When running line sets through a wall or roof, mark the lines to eliminate confusion as to which line set is running to which cylinder.

Example: Mark the liquid and suction lines with the respective cylinder number. Facing the front of the machine, cylinders are numbered left to right.
5. For line sets without piercing unions:
 - a. Seal the ends during installation to prevent exposure to the atmosphere and foreign objects
 - b. Blow the lines out with dry nitrogen to remove any debris that might be in the line sets.
 - c. When brazing the joints, purge dry nitrogen through the lines to minimize oxidation of copper inside of the lines. The Stoelting warranty does not cover problems with the refrigeration system that are caused by oxidized material in the lines.

B. RUNNING ELECTRICAL CONNECTIONS

1. The machine requires a separate electrical connection for each freezing cylinder. Refer to the nameplate on the machine for proper electrical supply. Each freezing cylinder has its own electrical system and condenser so if one cylinder fails, the other cylinder is still operational.

NOTE

An air-cooled machine needs two circuits for each freezing cylinder, one for the remote condensing unit and one for the freezing cylinder.

A water-cooled machine needs one circuit for each freezing cylinder.

2. The electrical boxes are located behind the lower front panel. Labels indicate which cylinder each electrical box powers. No pigtailed wires are supplied with the machine or condensing unit.
3. If the condensing unit is on the roof or ground, a quick disconnect box needs to be installed to provide power.
4. Do not turn on the power to the machine or the condensing unit until the refrigeration lines have been connected (the machine must have power for refrigerant charging). Label the circuit breakers with information regarding which cylinder and condensing unit the breaker is designated for to prevent confusion if power ever needs to be shut off.

5. When connecting power to the machine, run the line under the machine and through the bottom of the electrical box. Remove the electrical box cover by loosening the four screws. The screws do not have to be removed. Connect the power to the terminal strip. The terminal strip is labeled L1, L2, L3, and GND. After connections are made, place the cover on the electrical box, but do not tighten the cover (for single-phase machines the cover can be tightened). The electrical box may need to be accessed when checking for proper rotation of the motor.

C. PLUMBING CONNECTIONS

1. Water-cooled machines require 1/2" N.P.T. water and drain fittings. The connections are located at the back of the machine. Remove the rear panel to access the connections. Run the plumbing under the machine frame. Water-cooled machines use approximately 3 gallons of 75°F water per minute when the compressor is operating (per freezing cylinder). The machine does not use any water when not in use.
2. The machine is equipped with a dipping trough and faucet that require a cold water inlet line and a drain line. The water inlet has 1/2" NPT close nipple fitting. Install a shutoff valve in the water inlet line. The drain connection is 1-1/2". Run a drain line from the trough to a drain on the floor. Leave enough slack in the drain line so that the lower front panel can be easily removed for service.
3. If the machine is equipped with the hopper faucet option, run the hopper faucet tubing to the dipping trough inlet and install a T. This supplies water needed for the hopper faucet and the water valve for the dipping trough.

NOTE

The trough and faucet require a cold water line. Do not use a heated water source.

D. RECEIVING AND INSTALLING REMOTE CONDENSING UNITS

NOTE

The remote condensing units may be sent prior to delivery of the freezer.

The freezer requires one remote condensing unit per cylinder.

Remote condensers for 60Hz units are shipped from the factory charged with 20 lbs of refrigerant. Remote condensers for 50Hz units are shipped without refrigerant and require 20 lbs of refrigerant.

1. Upon arrival, check the entire remote condenser units for any damage that may have occurred during transit. With the method of packaging used, the remote condensers should arrive in excellent condition. The carrier is responsible for all damage in transit, whether visible or concealed. Do not pay the freight bill until the remote condenser units have been checked for damage. Have the carrier note any visible damage on the freight bill. If concealed damage or a shortage is found later, advise the carrier within 10 days and request inspection. The customer must place a claim for damages and/or shortages in shipment with the carrier. Stoelting cannot make any claims against the carrier.
2. Remove cardboard covering off the condensing units.
3. Place the condensing units in their predetermined location, either on the roof or on the ground. A crane or forklift is needed if the units are placed on a roof. The condensing units weigh approximately 200 lbs. each.
4. Using ratchet with a 1/2" socket, remove the two lag bolts that secure the condensing unit to the pallet.

5. Place the condensing units on 4" x 4" treated wood or similar material so that the units are not sitting directly on the ground or the roof. Secure the condensing units to the 4" x 4" using lag bolts. Adhere to all local, state, and federal codes governing this type of installation. Some areas have specific "hurricane-proof" requirements for roof installations. Allow at least 3 feet of clearance on the air intake and discharge sides of the condensers. Do not set the condensers so that one is blowing air directly into the other condensing unit. The ideal set up is to have all the condensing units set in a row (Fig. 2-1).
6. Connect the refrigeration lines to the condensing unit:

For condensing units without piercing unions

- a. Braze the suction line and liquid line from the line sets to the condensing unit. When brazing, wrap the shut off valve with a cold wet rag and make sure that the valve is fully open. If the valve is not wrapped, damage may result. When installing the suction line, angle it towards the condensing unit so that oil can flow back towards the compressor.
- b. Use good piping practices. Keep pipes as clean as possible. Do not let any debris or copper shavings get inside system otherwise the refrigeration valves may not work properly.

For condensing units with piercing unions

- a. Thread the line set fittings onto the condensing unit by hand.
- b. Tighten the fittings with a wrench until the coupling bodies "bottom out".
- c. Use a torque wrench to tighten the fittings to 46 ± 1 ft-lbs.

NOTE

The piercing unions are a one-time connection. Do not loosen the fittings after installing or refrigeration charge will be lost.

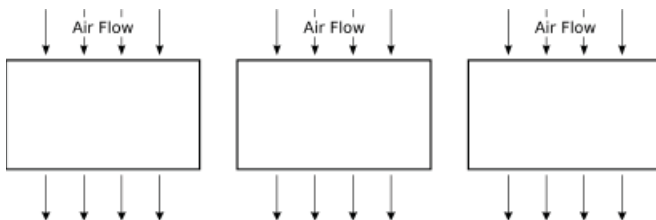

**Figure 2-1 Remote Condenser Installation
(Top View)**

E. SETTING IN PLACE AND MAKING MACHINE CONNECTIONS

1. Roll the machine into the desired location. Leave adequate space around the machine for the removal of service panels. Remove the left, right, back and lower front service panels.

NOTE

After the refrigeration lines are connected, air-cooled machines cannot be moved.

2. Use a pallet jack or floor jack to lift the front of the machine, remove the two shipping casters with a pair of channel locks, and install the stainless steel legs. Make sure the legs are adjusted all the way in, and screw two of the legs into the frame. Secure them tightly using channel locks. Repeat with the back of the machine.

NOTE

If the machine is water-cooled, casters are standard with machine.

3. Accurate leveling is necessary to ensure proper operation. Place a bubble level on top of the machine at each corner to check for level condition. If adjustment is necessary, level the machine by turning the bottom part of each leg or caster in or out.
4. To finish installing a water-cooled machine, proceed to "F. Running product and setting pressures for the custard machine".
5. Connect the refrigeration lines from the line sets to the machine.

For machines without piercing unions:

- a. Access the machine from the left or right service panel. The refrigeration system has a charge of dry nitrogen. Use caution when connecting the lines.
- b. Connect the suction line first then connect the liquid line. Run the refrigeration lines under the machine. There is approximately 6" of clearance between machine and the floor. The stainless steel legs are adjustable and can raise the machine up to 7" off the floor if necessary.
- c. Wrap the suction solenoid in a cold wet rag when soldering to prevent damage to the solenoid. Also, be aware of the electrical conduit inside custard machine while soldering the refrigeration lines.
- d. A liquid line dryer is supplied with the machine and should be the last connection made in the system. Use good piping techniques to keep the system clean. Do not leave the lines open and exposed for a long period.

For machines with piercing unions:

- a. Thread the line set fittings onto the machine by hand.
- b. Tighten the fittings with a wrench until the coupling bodies "bottom out".
- c. Use a torque wrench to tighten the fittings to 46±1 ft-lbs.

NOTE

The piercing unions are a one-time connection. Do not loosen the fittings after installing or refrigeration charge will be lost.

6. After finishing the refrigeration connections, connect power to the machine. Refer to "B. Running Electrical Lines" for the proper procedures. Check the rotation of the auger shaft. When looking at the machine from the front, the shaft needs to turn counterclockwise. If the shaft is turning the wrong direction, shut off power to the cylinder and switch the L1 and L3 wires. Check rotation again to verify the shaft is rotating counterclockwise. Once verified, tighten the screws on the electrical box cover.
7. If the machine is single phase and the auger shaft rotation is clockwise, then complete one of the following procedures. Check rotation after each procedure.
 - a. Change the T1 and T3 output leads going to the motor from the drive.
 - b. Change the leads inside the motor electrical box.
8. Condensing units for 60Hz machines ship from the factory with 20 lbs of refrigerant for up to a 50' line set. Add 1 lb of refrigerant for every 10' increase to the line set. Line set max 100'. Use good refrigeration practices to add additional charge to the system if needed. Make sure the suction solenoid is energized and that the shut off valves are open.

NOTE

Condensing units for 50Hz machines do not ship with refrigerant and require a full charge of R-448A during installation

F. RUNNING PRODUCT AND SETTING PRESSURES FOR THE CUSTARD MACHINE

NOTE

Complete the Custard Machine Start-Up and Training Checklist located with the spare parts kit or in the back of this manual and send it to Stoelting.

1. Remove all spare parts from the hopper before running product. Unwrap the parts and check for damage. Refer to the list in the back of this manual to make sure no parts are missing. The cylinders need to be under a load to set the pressures.
2. Install the flow valve and rotate it so the cutout is about 3/32" from the cutout in the hopper (see below). Fully close the flow control knob. Install the flow rod. If the flow rod cannot be installed without moving the flow valve, loosen the locknut on the rod and adjust it. Make sure both rod ends lay flat, then tighten the locknut.

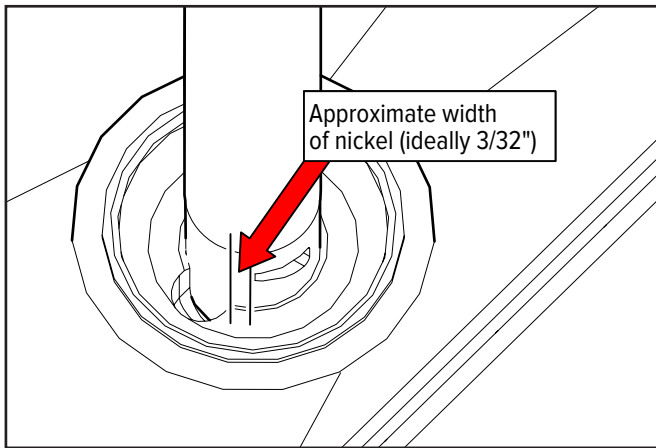

3. Disassemble, clean and sanitize each freezing cylinder. Refer to the Section 3 for proper instructions.
4. After assembling and sanitizing the machine, add custard mix to the hopper. Follow the instructions in the Section 3 to start freezing the custard (run one cylinder at a time to set the pressures). Connect gauges to the suction line and the discharge line. When product starts coming out of the faceplate, locate the low pressure gauge on the front of the machine and set the AXV to 30 psi. Remove the white plastic cap from the AXV and turn the valve counterclockwise to decrease the pressure or clockwise to increase the pressure. Turn the valve 1/4 turn at a time and wait at least 1 minute before making another adjustment. Connect a gauge to the suction line at the compressor and make sure the pressure is 25 psi. Adjust the crankcase pressure regulator (CPR) if the pressure is not correct. Remove threaded brass cap on the front of the CPR and adjust the valve with a 5/16" Allen wrench. Connect a gauge to the suction line at the hopper and adjust the hopper AXV to 55 psi.

5. Check the faceplate to see if the custard is at the desired texture and temperature. The standard normal serving temperature of frozen custard coming out of the machine is 18°-21°F.
6. Set the pressures for the remaining cylinders.

NOTE

If the machine is water-cooled, the discharge pressure was already set at the factory. Run custard mix through the machine to double-check and fine-tune the discharge pressure for the particular mix being used.

The remote condenser unit has a head pressure control set for 245 psi.

Custard mixes that use an extract flavoring run differently. Try different pressure settings by adjusting the AXV. Adjust the pressure setting between 28-32 psi (the machine does not operate correctly if the AXV is set lower than 28 psi).

7. If the machine is equipped with the lemon ice option, set the lemon ice AXV. The lemon ice option is designated for one cylinder (right cylinder). With the system still running product, turn the lemon ice switch on. The AXV is located behind the cylinder in front of the machine. Set the lemon ice AXV for 38-42 psi.
8. When testing is done, disassemble and clean the custard machine. Refer Section 3 for details.

Section 3 - Initial Set-Up and Operation

3.1 OPERATOR'S SAFETY PRECAUTIONS

SAFE OPERATION IS NO ACCIDENT; observe these rules:

- A. Know the machine. Read and understand the Operating Instructions.
- B. Notice all warning labels on the machine.
- C. Wear proper clothing. Avoid loose fitting garments, and remove watches, rings or jewelry that could cause a serious accident.
- D. Maintain a clean work area. Avoid accidents by cleaning up the area and keeping it clean.
- E. Stay alert at all times. Know which switch, push button or control you are about to use and what effect it is going to have.
- F. Disconnect electrical cord for maintenance. Never attempt to repair or perform maintenance on the machine until the main electrical power has been disconnected.
- G. Do not operate under unsafe operating conditions. Never operate the machine if unusual or excessive noise or vibration occurs.

3.2 OPERATING CONTROLS AND INDICATORS

Before operating the machine, it is required that the operator know the function of each operating control. Refer to Figure 3-1 for the location of the operating controls on the machine.



WARNING

Moving machinery can grab, mangle and dismember. Place the Freezing Cylinder Off/On switch in the OFF position before disassembling for cleaning or servicing.

A. Hopper Refrigeration OFF-ON Switch

The Hopper Refrigeration OFF-ON switch is a two-position rocker switch that supplies power to the hoppers. When the switch is in the OFF position, the hopper off light flashes. When the switch is in the ON position, the hopper refrigeration system operates.

B. Freezing Cylinder Off/On

The Freezing Cylinder OFF/ON switch is a two position rocker switch that supplies power to the freezing cylinder control circuit. When the switch is in the OFF position, the freezing cylinder's refrigeration system and auger do not operate. When the switch is in the ON position, the freezing cylinder is operational.

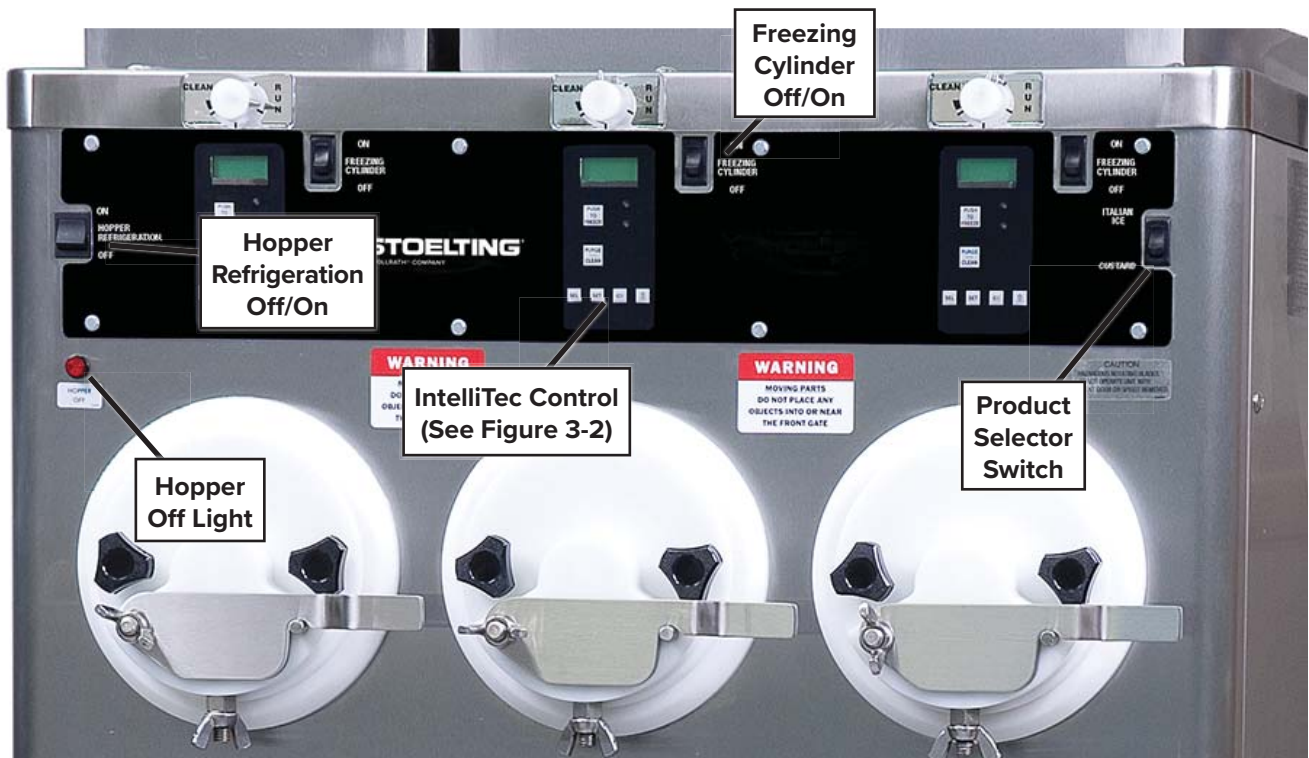

Figure 3-1 Machine Controls

C. Product Selector Switch

The product selector switch changes the refrigeration profile of the right freezing cylinder to allow two different products to be made. Before the machine is in ready mode, this switch can be moved to the desired profile.

D. Hopper Off Light

A flashing light indicates the Hopper Refrigeration Switch is in the OFF position; no refrigeration is being supplied to the hopper. Place the Hopper Refrigeration switch to the ON position for hopper refrigeration.

E. PUSH TO FREEZE Button

The PUSH TO FREEZE button initiates the run mode. To start the machine, place the Freezing Cylinder OFF-ON switch in the ON position then press the PUSH TO FREEZE button.

F. LEDs

The membrane switch features two lights; a green LED and an amber LED. The green LED flashes when the freezing cylinder is near ready mode and stays lit during ready mode. The amber LED is lit during standby, purge, and clean modes.

NOTE

If the machine enters an error condition, alternating green and amber lights flash. The LCD displays an error. Turn the Freezing Cylinder OFF-ON switch to the OFF position, correct the problem (Refer to Troubleshooting in Section 4) and turn the machine back on.

G. PURGE/CLEAN Button

PURGE Mode - When the PURGE/CLEAN button is pressed, the auger rotates. A PURGE message displays on the screen along with a 5-minute timer. Hopper refrigeration continues to run. When the timer gets to 0:00 and no other buttons are pressed, the machine enters standby mode.

CLEAN Mode - During PURGE mode, if the PURGE/CLEAN button is pressed, the CLEAN mode begins. The auger continues to rotate and hopper refrigeration stops.

H. Mix Low Light Indicator

The MIX LOW message appears on the LCD display to alert the operator of a low mix condition. The message displays when there is approximately one gallon of mix left in the hopper. When the MIX LOW message is displayed, refill hopper immediately.

NOTE

Failure to refill hopper immediately may result in operational problems.

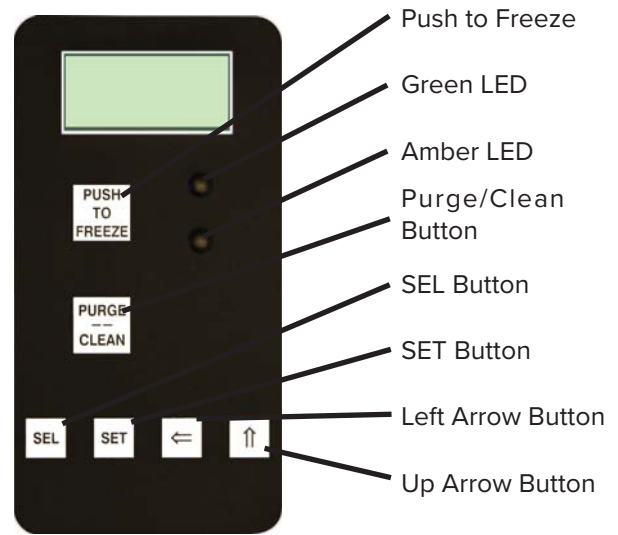

Figure 3-2 IntelliTec Control

I. Menu Navigation Buttons

The Menu Navigation Buttons are primarily used for machine calibration.

Selection Button (SEL) The SEL button is not functional in the normal operation mode. This button is only used by service technicians for machine calibration.

Set Button (SET) The SET button is not functional in the normal operation mode. This button is only used by service technicians for machine calibration.

Left Arrow Button (⇐) Pressing any button on the control panel automatically illuminates the display. The backlight turns off several seconds after use. To keep the display constantly lit, press and hold the left (⇐) button for five seconds. The backlight function can be reset to normal operation in the same manner.

Up Arrow Button (↑) The ↑ button is not functional in the normal operation mode. This button is only used by service technicians for machine calibration.

J. Front Door Safety Switch

The front door safety switch prevents the auger from turning when the front door is removed. The switch is open when the door is not in place and closed when the door is properly installed.

3.3 SANITIZING

Sanitizing must be done after the machine is cleaned and just before the hopper is filled with mix. Sanitizing the night before is not effective. However, you should always clean the machine and parts after each use.

NOTE

The United States Department of Agriculture and the Food and Drug Administration require that all cleaning and sanitizing solutions used with food processing equipment be certified for this use.

When sanitizing the machine, refer to local sanitary regulations for applicable codes and recommended sanitizing products and procedures. The frequency of sanitizing must comply with local health regulations.

Mix Stera Sheen sanitizer according to manufacturer's instructions to provide a 100 parts per million (ppm) strength solution. Mix sanitizer in quantities of no less than 2 gallons (7.5 liters) of 90° to 110°F (32° to 43°C) water. Allow sanitizer to contact the surfaces to be sanitized for 5 minutes. Any sanitizer must be used only in accordance with the manufacturer's instructions.

- A. Prepare Stera-Sheen Green Label Sanitizer or equivalent according to manufacturer's instructions to provide a 100ppm strength solution. Mix the sanitizer in quantities of no less than 2 gallons of 90° to 110°F (32° to 43°C) water. Any sanitizer must be used only in accordance with the manufacturer's instructions.
- B. Place the tapered end of the flow valve into the hopper drain hole with the arm pointing towards the left. Connect the flow control rod to the flow valve and the flow valve arm (Fig. 3-3).
- C. Make sure the flow control valve is shut by turning the control knob counterclockwise to the OFF position.



Figure 3-3 Flow Control Assembly

- D. Place a bucket under the slide.
- E. Pour the sanitizer into the hopper.

NOTE

A small amount of sanitizer may drain into the bucket with the flow control shut and may seep out of the rear seal.

- F. Clean sides of hopper, flow valve and underside of hopper cover using a sanitized soft bristle brush dipped in the sanitizing solution.
- G. Place the FREEZING CYLINDER OFF-ON switch in the ON position.
- H. Turn the flow control knob clockwise to the second band and wait 2 seconds.

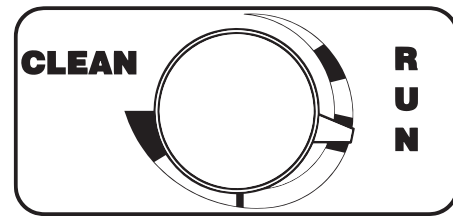

Figure 3-4 Flow Control Knob - Second Band

- I. Press the PURGE/CLEAN button twice. The display reads CLEAN and a 10-minute timer starts.
- J. Slightly open the front gate. Ensure sanitizer comes in contact with all surfaces (5 minutes).
- K. Turn the flow control knob fully open (clockwise) to drain the sanitizer from the freezing cylinder.
- L. When the sanitizer has drained from the hopper, place the FREEZING CYLINDER switch and flow control knob OFF.

3.4 FREEZE DOWN AND OPERATION

This section covers the recommended operating procedures to be followed for the safe operation of the machine. The flow control settings may be different depending on the mix. Adjust as necessary.

NOTE

The following instructions are for making custard. If making Italian ice, go to Section 3.7.

- A. Sanitize just prior to use.

NOTE

Make sure the flow control assembly is in place before adding mix and that the flow control knob is set to the OFF position.

- B. Turn the HOPPER REFRIGERATION switch ON.
- C. Fill the hopper with pre-chilled (40°F or 4°C) mix.
- D. Place the FREEZING CYLINDER switch in the ON position. The display reads STANDBY MODE.
- E. Press the PURGE/CLEAN button. The display reads PURGE.

- F. Turn the flow control knob to the second band for approximately 3 seconds then turn the knob to “OFF”.

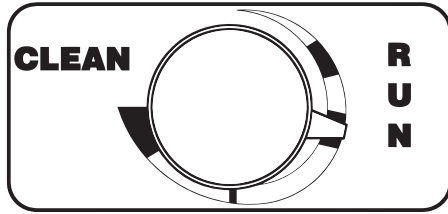

Figure 3-5 Flow Control Knob - Second Band

- G. Open the front gate to allow custard mix and sanitizer to exit the front gate and discard the product.
- H. Press the PURGE/CLEAN button twice to stop the auger and close the front gate.
- I. Press the PUSH TO FREEZE button. The display reads CUSTARD and a bar on the second line starts to fill.
- J. When the display reads CUSTARD READY, the freezing cylinder is at the correct temperature (Fig. 3-6).

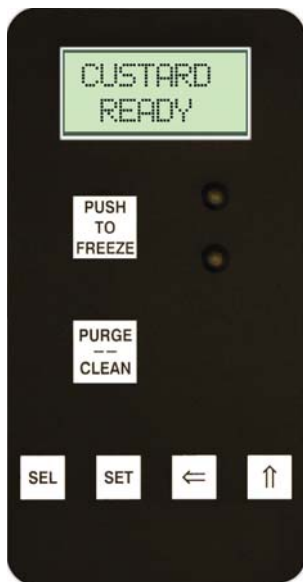

Figure 3-6 Custard Mode

- K. Open the front gate.
- L. Turn the flow control knob to the first band. After a few minutes, a ribbon of product starts to form.

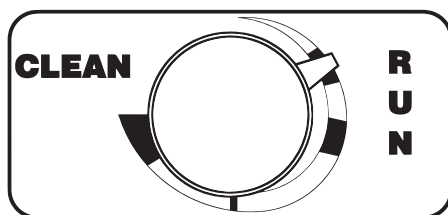

Figure 3-7 Flow Control Knob - First Band

- M. Adjust the flow control knob until the product flow fills the faceplate outlet and is at the desired texture (Fig. 3-8). The flow control knob setting is different for each type of product.

NOTE

Adjustments take up to 1 minute before a noticeable difference is seen in the product.

NOTE

A high-pitched noise from the freezing cylinder is an indication that there is not enough mix entering the barrel. Slowly turn the flow control knob clockwise to increase the flow. It can take up to 1 minute for the adjustment to stop the noise.

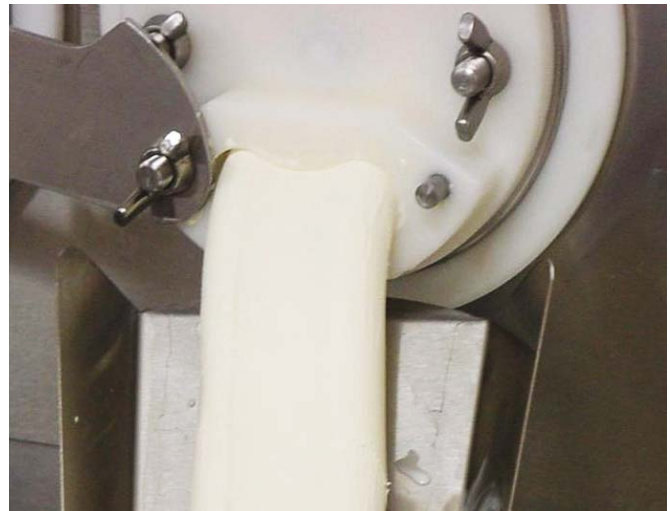

Figure 3-8 Proper Flow

3.5 HOLD CYCLE

- A. Turn flow control knob to the OFF position.
- B. Press the PURGE/CLEAN button. The display reads PURGE
- C. Use the pin cleaning tool to clear the product from the pins on the faceplate. Only use pin cleaning tool part [2206335](#) in machines with the front extended wing blade. Do not use part [2202377](#) with front extended wing blades as damage to the machine and tool can occur.

NOTE

Restricted custard over beats, which affects taste and texture.



WARNING

Hazardous Moving Parts

Never put hands, fingers or any object into the front gate during operation of the custard machine.

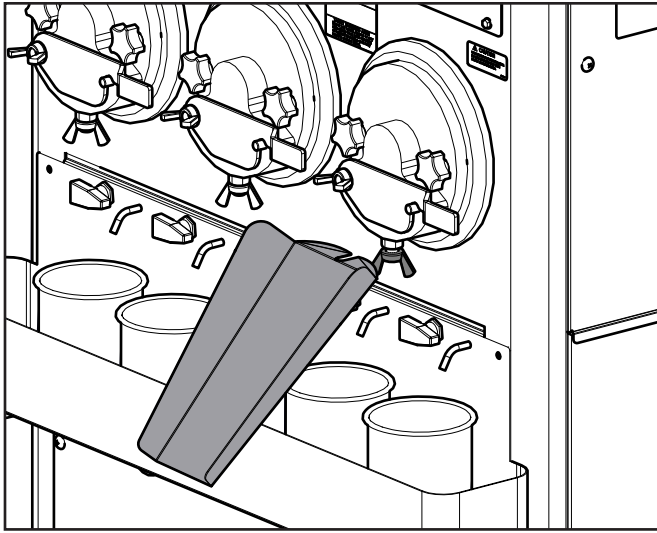

Figure 3-9 Remove Slide

- D. After the timer expires and all usable product is removed, close the gate.
- E. Remove the slides.
- F. Clean excess product from the faceplate.

3.6 PRODUCTION FROM HOLD

- A. Press the PUSH TO FREEZE button.
- B. Open the front gate. Collect any liquid mix that comes out of the freezing cylinder in a sanitized container and treat it as rerun.
- C. When the display reads CUSTARD READY, the freezing cylinder is at the correct temperature and the auger starts automatically.
- D. Turn the flow control knob clockwise to the second band. A small amount of mix will drain from the machine.

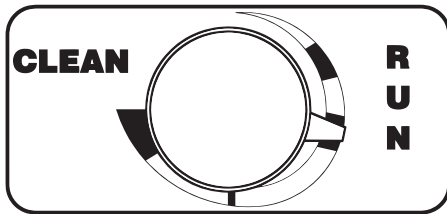

Figure 3-10 Flow Control Knob - Second Band

- E. Gradually adjust the flow control knob to gain the desired custard texture.
- F. Install the custard slide.

NOTE

A growling or chattering noise during production indicates that not enough mix is entering the barrel. Slightly increase the flow. There are several minutes of lag time between increasing flow and eliminating the growling or chattering.

3.7 ITALIAN ICE FREEZE DOWN AND OPERATION

- A. Sanitize just prior to use.

NOTE

Make sure the flow control assembly is in place before adding Italian ice and that the flow control knob is set to the OFF position.

- B. Turn the HOPPER REFRIGERATION switch ON.
- C. Fill the hopper with pre-chilled (40°F or 4°C) Italian ice.
- D. Place the FREEZING CYLINDER switch in the ON position. The display reads STANDBY MODE.
- E. Press the PURGE/CLEAN button. The display reads PURGE.
- F. Turn the flow control knob to the first band for approximately 3 seconds then turn the knob to

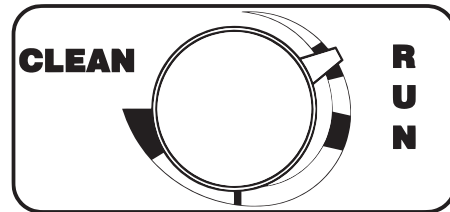

Figure 3-11 Flow Control Knob - First Band

“OFF”.

- G. Open the front gate to allow Italian Ice and sanitizer to exit the front gate and discard the product.
- H. Press the PURGE/CLEAN button twice to stop the auger and close the front gate.
- I. Press the PUSH TO FREEZE button. The display reads ITALIAN ICE and a bar on the second line starts to fill. If the display reads CUSTARD, move the product selector switch on the front of the machine to ITALIAN ICE.
- J. When the display reads ITALIAN ICE READY, the freezing cylinder is at the correct temperature.

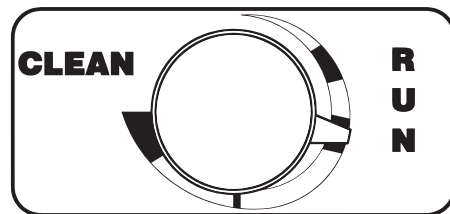

Figure 3-12 Flow Control Knob - Second Band

- K. Open the front gate.
- L. Turn the flow control knob to the second band.
- M. When product starts to collect at the front door, increase the flow control knob to the second band. Use the pin cleaning tool to remove product from the pins until the Italian Ice fills the entire width of the opening.

NOTE

Use the pin cleaning tool anytime the Italian Ice becomes restricted during production. Only use pin cleaning tool part 2206335 in machines with the front extended wing blade. Do not use part 2202377 with front extended wing blades as damage to the machine and tool can occur.

- N. Gradually adjust the flow control knob in small increments until Italian Ice flow is consistent.

HOLD CYCLE - ITALIAN ICE

- A. Turn flow control knob to the OFF position.
- B. Press the PURGE/CLEAN button. The display reads PURGE
- C. Use the pin cleaning tool to clear the product from the pins on the faceplate.

 WARNING
Hazardous Moving Parts
Never put hands, fingers or any object into the front gate during operation of the custard machine.

- D. After the timer expires and all usable product is removed, close the gate.
- E. Remove the slide.
- F. Clean excess product from the front plate.

PRODUCTION FROM HOLD - ITALIAN ICE

- A. Press the PUSH TO FREEZE button.
- B. Install the slide and open the front gate.
- C. When the display reads ITALIAN ICE READY, the freezing cylinder is at the correct temperature and the auger starts automatically.
- D. Turn the flow control knob to the first band and adjust it to the second band when product starts to collect at the pins. Use the pin cleaning tool to remove product from the pins until Italian Ice comes out the entire width of the opening.

3.8 REMOVING MIX FROM MACHINE

To remove the mix from the machine, refer to the following steps. Make sure the gate on the faceplate is open.

NOTE

The following instructions are for both custard and Italian ice.

- A. Press the PURGE/CLEAN button. The display reads PURGE.
- B. Press the PURGE/CLEAN button again. The display reads CLEAN and a 10-minute timer starts.
- C. Once the timer has expired, allow the barrel to rest for at least 5 minutes before removing the custard.
- D. If there is mix in the hopper, place a sanitized container at the opening of the front plate.
- E. Open the flow control valve fully by turning the flow control knob clockwise to the CLEAN position.
- F. After the hopper and freezing cylinder have drained, place the FREEZING CYLINDER and HOPPER REFRIGERATION switches in the OFF position.
- G. Close the front gate.
- H. Cover, label, date and place the sanitized container in the walk-in cooler.

3.9 CLEANING THE MACHINE

NOTE

The frequency of cleaning the machine and machine parts must comply with local health regulations.

After the mix has been removed from the machine, the machine must be cleaned. To clean the machine, refer to the following steps:

- A. Place a container under the slide of the faceplate. Fill the hopper with 2 to 4 gallons of tap water (Not to exceed 100°F).
- B. Replace the front gate with the splash guard and turn the flow control knob to the second band.
- C. Press the PURGE/CLEAN button twice. The display reads CLEAN.
- D. Allow the water to drain.
- F. When the water has drained, press the PURGE/CLEAN button again to stop the CLEAN cycle.
- G. Prepare Stera-Sheen Green Label Sanitizer or equivalent according to manufacturer's instructions to provide a 100ppm strength solution (follow the instructions on the package). Any sanitizer must be used only in accordance with the manufacturer's instructions
- H. Place a bucket under the slide.

- I. Pour 1 (to 1 1/4) gallons of the sanitizer into the hopper. Using a clean sanitized brush, ensure all the surfaces of the hopper have been sanitized.
- J. Press the PURGE/CLEAN button twice. The display reads CLEAN
- K. Turn the flow control knob clockwise to the second band.

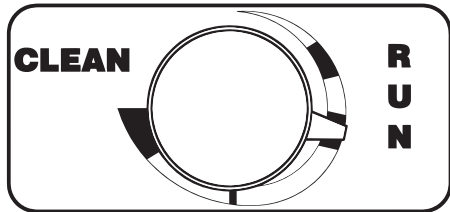

Figure 3-13 Flow Control Knob - Second Band

- L. Allow the sanitizer to drain (approximately 5 minutes).
- M. When the sanitizer has drained from the hopper, place the Freezing Cylinder switch and flow control knob OFF.

3.10 DISASSEMBLY OF MACHINE PARTS

Inspection for worn or broken parts should be made each time the machine is disassembled. All worn or broken parts should be replaced to ensure safety to both the operator and the customer and to maintain good machine performance and a quality product. Frequency of cleaning must comply with local health regulations.

To disassemble the machine, refer to the following steps:

	CAUTION
Hazardous Moving Parts	
<p>Revolving auger shaft can grab and cause injury. Place the Freezing Cylinder OFF-ON switch in the OFF position before disassembling for cleaning or servicing.</p>	

- A. Remove the flow control rod and flow control valve from the hopper by pulling straight up.
- C. Remove the slide from the faceplate and remove the faceplate.
- D. Remove the front wear bushing.

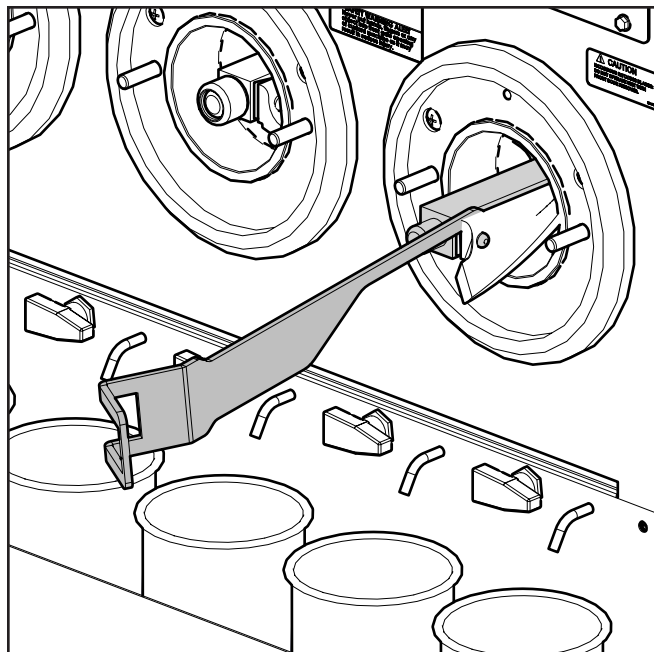

Figure 3-15 Removing Auger

- F. Remove the auger assembly from the machine. Pull the auger out of the freezing cylinder slowly using the shaft wrench. As the auger is being pulled out, carefully remove each of the blades and springs.
- G. Keep the rear of the auger shaft tipped up once it is clear of the machine to avoid dropping the rear seal.
- H. Remove the rear seal.
- I. Wipe the lubricant from the drive end (rear) of the auger with a cloth or paper towel.

3.11 CLEANING THE MACHINE PARTS

Disassembled machine parts require complete cleaning, sanitizing and air drying before assembling. Local and state health codes dictate the procedure required. Some state health codes require a four sink process (pre-wash, wash, rinse, sanitize, air dry), while others require a three sink process (without the pre-wash step). The following procedures are a general guideline only. Consult your local and state health codes for the procedures required in your location.

Place all loose parts in a pan or container and take to the wash sink for cleaning. To clean machine parts refer to the following steps:

- A. Prepare cleaning solution to manufacturers recommendation.
- B. Place all parts in cleaning solution and clean with provided brushes.

- C. Wash the hopper and freezing cylinder with sanitized water and the designated long handle brush. Clean the rear seal surfaces on the inside of the freezing cylinder.
- D. Clean the drip pan located at the back of the machine in the access panel. Wipe down the exterior of the entire machine, top to bottom, with sanitized water.
- E. Polish the machine exterior with a clean dry cloth.
- F. Rinse all parts with clean 90° to 110°F (32° to 43°C) water.
- G. Place all parts in a sanitizing solution for 5 minutes, then remove and let air dry completely before assembling the machine.

NOTE

If the machine is not going to be immediately operated, store the faceplate in a clean and sanitized container in a cooler.

3.12 ASSEMBLY OF MACHINE

To assemble the machine parts, refer to the following steps:

NOTE

Total Blend sanitary lubricant or equivalent must be used when lubrication of parts is specified.

Total Blend can be used to lubricate parts and as a spline lubricant. Do not use more than one packet of Total Blend per freezing cylinder.

NOTE

The United States Department of Agriculture and the Food and Drug Administration require that lubricants used on food processing equipment be certified for this use. Use lubricants only in accordance with the manufacturer's instructions.

- A. Install the rear gasket onto the auger shaft. Do not lubricate the rear gasket.
- B. Lubricate the hex end of the auger shaft with a small amount of Total Blend lubricant.
- C. Install the springs and blades onto the first two positions at the rear of the auger shaft.

NOTE

Use the standard blades for each position on the auger shaft except the front most pins, which take the extended wing blades.

- D. Rest the auger shaft inside the barrel with the first blade facing down. Push the auger inwards and rotate it until second blade is facing down.

NOTE

Do not drop the auger shaft inside the barrel. This causes serious damage to the barrel surface

- E. Rotate the auger shaft clockwise and place the next spring and blade on the pins. Continue until all 12 springs and blades are installed. Make sure to install the extended wing blade on the front pins of the auger.

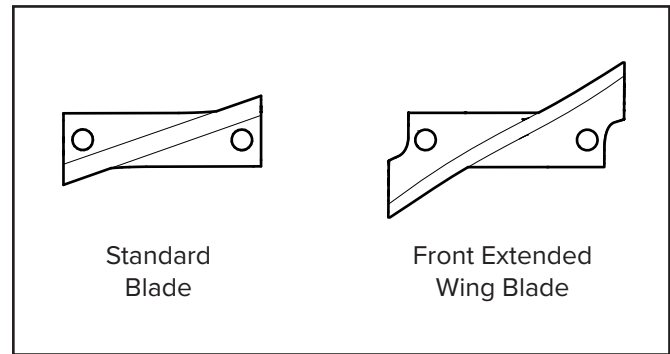

Figure 3-16 Auger Blades

- F. Using the auger shaft wrench, push and turn the auger shaft until it engages with the drive coupling in the back of the machine.

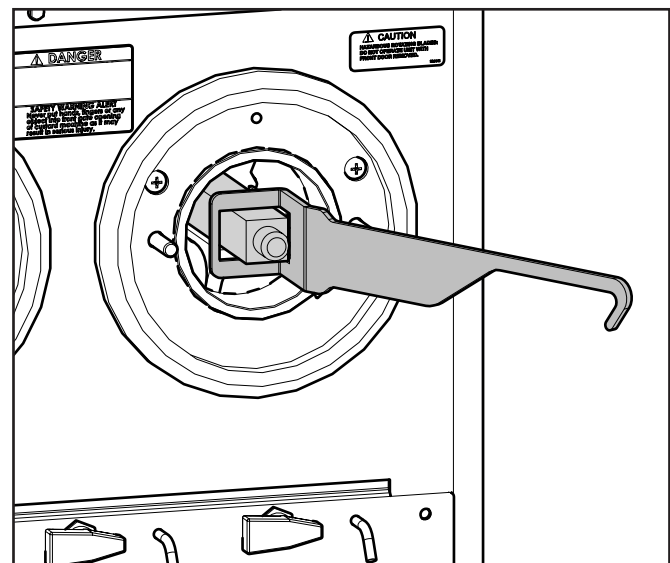

Figure 3-17 Rotate Auger Shaft to Engage

- G. Lubricate the front end of the auger shaft and the inside of the front plate, where the bushing sits, with Total Blend lubricant.
- H. Lubricate the inside and outside of the front bushing with Total Blend lubricant. Place the bushing on the end of the auger shaft.
- I. Place the large o-ring onto the front plate with a small amount of Total Blend lubricant.
- J. Install the front plate onto the machine and secure the front gate.
- K. The machine is now ready for sanitizing.

3.13 ROUTINE CLEANING

To remove spilled or dried mix from the machine exterior, wash in the direction of the finish grain with warm soapy water and wipe dry. Do not use highly abrasive materials, as they mar the finish.

3.14 PREVENTATIVE MAINTENANCE

Use the following maintenance schedule to keep the machine clean and operating properly.

A. DAILY

Disassemble and Clean

The frequency of cleaning the freezer and freezer parts must comply with local health regulations. Refer to the previous sections for proper disassembly and cleaning instructions.

Lubricate Front Bushing

Total Blend lubricant or equivalent must be used when lubrication of parts is specified. Apply a thin film of lubricant to the inside and outside of the front bushing.

Inspect Parts

Inspect parts for wear or breakage each time the freezer is disassembled. Replace all worn or broken parts to ensure safety to both the operator and the customer and to maintain good freezer performance and a quality product.

Lubricate Hex End of the Auger

Lubricate the hex end of the auger with a small amount of Total Blend lubricant.

B. WEEKLY

Service Technician Only - Clean Inside Of Machine

Remove all side panels and clean the inside of the machine. Wipe any custard that may have dripped onto the inner panels with a damp soapy towel. Wash the drain tray.

C. MONTHLY

Service Technician only - Clean Condenser Coils (And Filters If Applicable)

The coils on the hopper, dipping cabinet and remote condenser need to be cleaned to ensure proper airflow. Use compressed air to clean the condensers. Blow the air in the opposite direction of the normal airflow.

C. SEMI-ANNUALLY

Replace Barrel Parts According To Schedule

Follow the Parts Replacement Schedule to keep the freezer operating properly.

D. ANNUALLY

 WARNING
<p>High voltage will shock, burn or cause death. Turn off and lock out main power disconnect before servicing. Do not operate machine with panels removed.</p>

Replace Barrel Parts

Follow the Parts Replacement Schedule below to keep the freezer operating properly.

Service Technician Only - Drive Belt Wear and Tension

Inspect the drive belts for wear. Check for wear marks from the belts rubbing on the pulley. Use a Burroughs Belt Tension Gauge to set the tension for the drive belt. Set the belt tension to 40-50 lbs. If an adjustment is necessary, loosen the four motor plate retaining nuts, adjust the belt tension then retighten the four nuts.

3.15 EXTENDED STORAGE

Refer to the following steps for winterizing the machine or for storing the machine over any long period.

- A. Clean all of the parts that come in contact with mix thoroughly with warm detergent. Rinse in clear water and dry all parts. Do not sanitize.

NOTE

Do not let cleaning solution stand in machine barrel during the shutdown period.

- B. Remove, disassemble, and clean the front door and auger shaft. Leave disassembled during the shutdown period.
- C. Place the plastic auger flights in a plastic bag with a moist paper towel. This will prevent the flights from becoming brittle if exposed to dry air over an extended period (over 30 days).

Part	Description	Semi-Annually	Annually	Qty per Barrel
C-2000-50	Spring		X	12
C-2000-51	Blade - Standard		X	11
2206165	Blade - Front Extended Wing		X	1
SL-0010	Seal - Auger Shaft	X		1
149014	Bushing - Front Auger Support	X		1
625174	O-Ring - Front Door	X		1

Figure 3-18 Parts Replacement Schedule

- D. For water-cooled machines that are left in unheated buildings, or buildings subject to freezing, the water must be shut off and disconnected. Disconnect the water inlet fitting. The fitting is located at the rear of the machine. Run the compressor for 2 - 3 minutes to open the water valve (the front door must be attached for the compressor to run). Blow out all the water through the water inlet. Drain the water supply line coming to the machine. Disconnect the water outlet fitting.
- E. Disconnect the machine from the source of the electrical supply in the building.

Section 4 - Troubleshooting

4.1 ERROR CODES

When the machine experiences a problem, one of the following error codes is displayed on the control panel. Each error code directs you to the system location of the malfunction.

ERROR CODE	MALFUNCTION
1	Soft
2	High Torque
3	Extended Run Time
4	Clean
5	Barrel Sensor
6	Hopper Sensor
7	Drive Motor
8	Cab Sensor
9	High Pressure Cutout
10	Auxiliary Sensor
12	Hopper Sensor
13	Hopper Sensor

To return the machine to normal operation, any error causing condition must be corrected and the Freezing Cylinder Off/On switch must be placed in the OFF position and back in the ON position before the machine returns to normal operation.

4.2 TROUBLESHOOTING ERROR CODES

Error Code 1 - Soft Error

The Soft Error (E1) is an internal control board error that is logged for future analysis. The refrigeration is never stopped and the machine continues to operate normally.

Error Code 2 - High Torque

If the control panel displays a High Torque Error (E2), the drive motor is running at a high load for 10 or more seconds. Place the Freezing Cylinder Off/On switch in the OFF position, wait until the product in the barrel thaws to a reasonably soft consistency and return the switch to the ON position. If the error persists, contact White Glove Service for further assistance.

Error Code 3 - Run Time

The Run Time Error (E3) occurs when the compressor runs continuously for an extended period. This error could happen if the cutout value is not attained during “Standby Mode” or if the “Ready” signal does not come on in “Custard Mode” or “Italian Ice Mode”.

This error is generally caused by very low mix levels in the hopper or from product breakdown. Check the mix in the hopper. If the level mix is low, add mix. If there is a possibility that the mix has broken down, clean and sanitize the machine and replace the mix with fresh product.

Ice crystals in the hopper can clog the mix inlet system and prevent mix from entering the freezing cylinder. Thoroughly thaw mix per manufacturer’s recommendations. To check for ice crystals, pour a small amount of product from the mix container through a clean and sanitized sieve or strainer. If ice crystals are in the mix, check temperature of the walk-in cooler where the mix is stored.

If the error persists after attempting to clear it, contact White Glove Service for further assistance.

Error Code 4 - Clean

If the machine is left in the Clean Mode for more than 10 minutes, the control panel displays a Clean Error (E4). This condition does not reflect a problem with the machine itself. The Clean Error has been programmed into the controller as a safeguard to protect the machine from potential damage caused by the machine being accidentally left in “Clean Mode”. The control attempts to restart itself after 5 minutes. The display then flashes and reads Restart. To immediately clear the Clean Error, place the Freezing Cylinder Off/On switch in the OFF position and back in the ON position. After the Clean Error has been cleared, the machine starts a refrigeration cycle to protect the product in case the clean button was pressed by mistake.

Error Code 5 - Freezing Cylinder Sensor

The Freezing Cylinder Sensor Error (E5) indicates a failure of the barrel sensor or if the sensor is out of range. If the error occurs, contact White Glove Service for further assistance.

NOTE

When the machine encounters a Freezing Cylinder Sensor Error, it continues to run using preset timers. This mode allows the freezing cylinder to continue making product until it can be serviced.

Error Code 6 - Hopper Sensor

The Hopper Sensor Error (E6) does not occur on a CC model machine.

Error Code 7 - Drive Motor

If the control panel displays a Drive Motor Error (E7), the control does not sense the drive motor. If the error occurs, contact White Glove Service for further assistance.

Error Code 8 - Cab Sensor

A Cab Sensor Error (E8) does not occur on a CC model machine.

Error Code 9 - High Pressure Cutout

High Pressure Cutout Errors (E9) are usually caused by a dirty or inefficient condenser. If the control panel displays an E9 on an air cooled machine, check for proper air clearance around the condenser. In a water cooled machine, check that the water is not shut off. If the error persists, contact White Glove Service for further assistance.

Error Code 10 - Auxiliary Sensor

An Auxiliary Temperature Sensor Error (E10) occurs if the temperature sensor on the control board fails. If the error occurs, contact White Glove Service for further assistance.

Error Code 12 - Right Hopper Sensor

The Right Hopper Sensor Error (E12) indicates a hopper temperature sensor failure. This error also appears if the sensor is out of range. If the error occurs, contact White Glove Service for further assistance.

Error Code 13 - Left Hopper Sensor

The Left Hopper Sensor Error (E13) indicates a hopper temperature sensor failure. This error also appears if the sensor is out of range. If the error occurs, contact White Glove Service for further assistance.

ALTERNATING FLASHING CONTROL PANEL LIGHTS

The display panel lights flash in an alternating sequence under any error code. Clear the error and place the Freezing Cylinder Off/On switch in the OFF position and back in the ON position.

4.3 TROUBLESHOOTING TABLES

PROBLEM	POSSIBLE CAUSE	REMEDY
Custard is running too cold or auger blades chatter during running.	<ol style="list-style-type: none"> 1 Flow is not high enough. 2 Hopper is low or out of mix. 3 Flow valve is plugged. 4 The refrigeration system is set too cold for the mix. 	<ol style="list-style-type: none"> 1 Increase the flow. Machine needs to run for at least a minute before seeing a change in the product. 2 Add Mix 3 Check flow valve. 4 Call Stoelting White Glove Service.
Custard has gritty texture	<ol style="list-style-type: none"> 1 Blades or springs are worn 2 The refrigeration system is set too cold for the mix. 	<ol style="list-style-type: none"> 1 Inspect and replace worn parts 2 Call Stoelting White Glove Service.
Custard is running too soft.	<ol style="list-style-type: none"> 1 Flow is too high. 2 The refrigeration system for that barrel set too warm for the mix. 3 Condenser on remote unit is blocked. 4 Water cooled machine has water shut off. 5 Refrigeration system not functioning correctly. 	<ol style="list-style-type: none"> 1 Decrease the flow. Machine needs to run for at least a minute before you see a change in the product. 2 Call Stoelting White Glove Service. 3 Check for blockage and clean if necessary. 4 Check that water is connected and turned on. 5 Call Stoelting White Glove Service.
Beater motor freezes up in the run mode.	<ol style="list-style-type: none"> 1 Hopper is low or out of mix. 2 Flow valve is plugged. 3 Belt is loose and slipping. 	<ol style="list-style-type: none"> 1 Add Mix 2 Check flow valve. 3 Check the belt and tighten if necessary.
Restriction of custard or lemon ice in the faceplate	<ol style="list-style-type: none"> 1 Restriction in the faceplate. 2 Solid obstruction in faceplate. 	<ol style="list-style-type: none"> 1 Use the rake to free the restriction and increase the flow rate setting by about 0.5. After a minute, repeat these steps if no results are seen. 2 Inspect the flow valve for solid custard or lemon pulp obstruction in the hopper.
Excess liquid mix in the barrel after purge mode.	<ol style="list-style-type: none"> 1 Flow valve not fully closing 	<ol style="list-style-type: none"> 1 Check the flow rod length and adjust if necessary (see Section 2. Part F)

Section 5 - Replacement Parts

5.1 DECALS AND LUBRICATION

Part	Description	Quantity
BR-0020	Brush - Tubing (1/2")	1
BR-0030	Brush - Head (Barrel)	1
BR-0035	Brush - Handle (Barrel)	1
C-1000-25F	Decal - Caution 100 Degree	2
C-1000-25I	Decal - L.H. Barrel	1
C-1000-25J	Decal - Center Barrel	1
C-1000-25K	Decal - R.H. Barrel	1
C-1000-26C	Decal - Made In USA	1
C-2000-57	Wrench - Beater Shaft	1
C74	O-Ring Pick	1
236058	Card - Cleaning Instruction	1
244138	Caster - Non-Locking (4") (Each)	2
244139	Caster - Locking (4") (Each)	2
324007	Decal - Flow Valve #754140	1 per barrel
324065	Decal - Water Inlet	-
324105	Decal - Caution Electrical Shock	-
324106	Decal - Caution Electrical Wiring Materials	-
324141	Decal - Caution Rotating Blades	-
324208	Decal - Attention Refrigerant Leak Check	-
324346	Decal - Caution Hazardous Moving Parts	-
324509	Decal - Cleaning Instructions	-
324566	Decal - Wired According To	-
324594	Decal - Attention Heat Sensitive	2
324686	Decal - Danger Automatic Start	2
324890	Decal - Hopper Off	1
324894	Decal - Flow Control #754017	1 per barrel
324900	Decal - Safety Warning Alert	1
324907	Decal - Holding Product	-
325032	Decal - White Glove Service	1
490760	Leg	4
508053	Lubricant - Total Blend (50 Packets)	1
2206335*	Pin Cleaning Tool - Front Door	1

* Only use pin cleaning tool part [2206335](#) in machines with the front extended wing blade. Do not use part [2202377](#) with front extended wing blades as damage to the machine and tool can occur.

5.2 AUGER SHAFT AND FACEPLATE PARTS

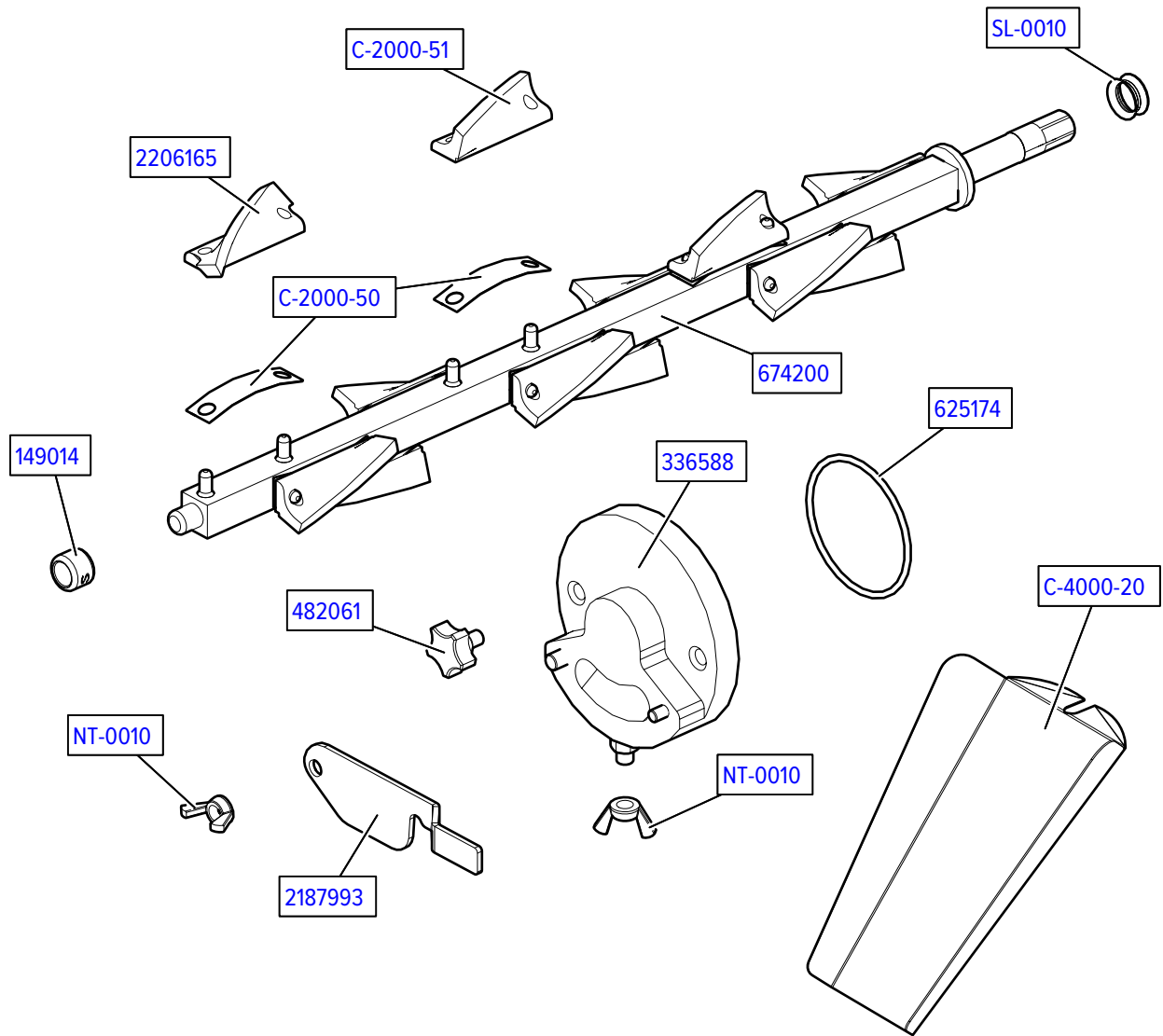

Part	Description	Quantity
C-2000-50	Spring	12 per barrel
C-2000-51	Blade - Standard	11 per barrel
C-4000-14	Guard Splash	1
C-4000-19	Slide - Long (Chute)	1
C-4000-20	Slide - Short (Chute)	1
NT-0010	Wing Nut - Stainless Steel	2 per barrel
SL-0010	Seal - Beater Shaft	1 per barrel
149014	Bushing - Front Auger Support	1 per barrel
336588	Face Plate	1 per barrel
482061	Knob - Front Door (Stainless)	2 per barrel
625174	O-Ring - Front Door - Red	1 per barrel
674200	Auger Shaft	1 per barrel
2187993	Gate - Front	1 per barrel
2206165	Blade - Front Extended Wing	1 per barrel

5.3 HOPPER PARTS

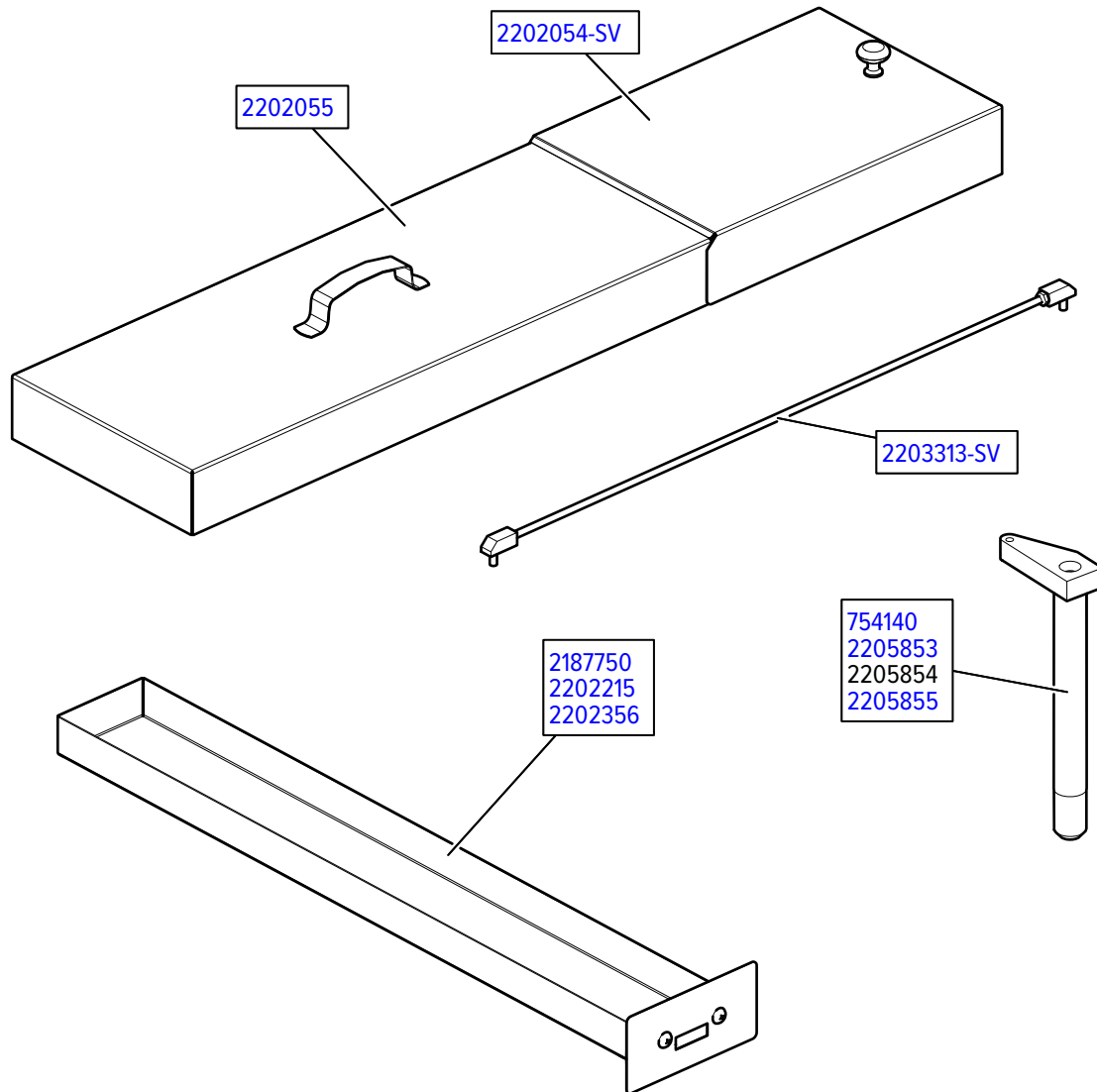

Part	Description	Quantity
754140	Flow Valve Only	1 per barrel
2187750	Tray - Drain (CC303)	1
2202054-SV	Cover - Rear Hopper w/Handle	1 per barrel
2202055	Cover - Front Hopper w/Handle	1 per barrel
2202215	Tray - Drain (CC202)	1
2202356	Tray - Drain (CC404)	1
2203313-SV	Flow Control Rod Assembly	1 per barrel
2205853	Flow Valve Kit (CC202) (Includes (2) Each #754140 & #324007)	1
2205854	Flow Valve Kit (CC303) (Includes (3) Each #754140 & #324007)	1
2205855	Flow Valve Kit (CC404) (Includes (4) Each #754140 & #324007)	1

