



Model E131G & F131G
SERVICE MANUAL

Manual No. [513537-3](#)

Mar. 2004

This manual provides basic information about the machine. Instructions and suggestions are given covering its operation and care.

The illustrations and specifications are not binding in detail. We reserve the right to make changes to the machine without notice, and without incurring any obligation to modify or provide new parts for machines built prior to date of change.

DO NOT ATTEMPT to operate the machine until instructions and safety precautions in this manual are read completely and are thoroughly understood. If problems develop or questions arise in connection with installation, operation, or servicing of the machine, contact Stoelting.



stoeltingfoodservice.com

Stoelting Foodservice Equipment
502 Highway 67
Kiel, WI 53042-1600
U.S.A.

Main Tel: 800.558.5807
Fax: 920.894.7029

Customer Service: 888.429.5920
Fax: 800.545.0662
Email: foodservice@stoelting.com

© 2014 PW Stoelting, LLC

A Few Words About Safety

Safety Information

Read and understand the entire manual before operating or maintaining Stoelting equipment.

This manual provides the operator with information for the safe operation and maintenance of Stoelting equipment. As with any machine, there are hazards associated with their operation. For this reason safety is emphasized throughout the manual. To highlight specific safety information, the following safety definitions are provided to assist the reader.

The purpose of safety symbols is to attract your attention to possible dangers. The safety symbols, and their explanations, deserve your careful attention and understanding. The safety warnings do not by themselves eliminate any danger. The instructions or warnings they give are not substitutes for proper accident prevention measures.

If you need to replace a part, use genuine Stoelting parts with the correct part number or an equivalent part. We strongly recommend that you do not use replacement parts of inferior quality.



Safety Alert Symbol:

This symbol Indicates danger, warning or caution. Attention is required in order to avoid serious personal injury. The message that follows the symbol contains important information about safety.

Signal Word:

Signal words are distinctive words used throughout this manual that alert the reader to the existence and relative degree of a hazard.



The signal word “WARNING” indicates a potentially hazardous situation, which, if not avoided, may result in death or serious injury and equipment/property damage.



The signal word “CAUTION” indicates a potentially hazardous situation, which, if not avoided, may result in minor or moderate injury and equipment/property damage.

CAUTION

The signal word “CAUTION” not preceded by the safety alert symbol indicates a potentially hazardous situation, which, if not avoided, may result in equipment/property damage.

NOTE (or NOTICE)

The signal word “NOTICE” indicates information or procedures that relate directly or indirectly to the safety of personnel or equipment/property.

TABLE OF CONTENTS

SECTION	DESCRIPTION	PAGE
SECTION 1	INTRODUCTION	
1.1	Description	1
1.2	Specifications	1
SECTION 2	INSTALLATION INSTRUCTIONS	
2.1	Safety Precautions	3
2.2	Shipment and Transit	4
2.3	Freezer Installation	4
2.4	Floor Stand Installation	5
2.5	Installing Permanent Wiring	5
SECTION 3	INITIAL SET-UP AND OPERATION	
3.1	Operator's Safety Precautions	7
3.2	Operating Controls and Indicators	7
3.3	Sanitizing	8
3.4	Freeze Down and Operation	9
3.5	Mix Information	10
3.6	Removing Mix Inlet Regulator	11
3.7	Cleaning the Freezer	11
3.8	Disassembly of Freezer Parts	11
3.9	Cleaning the Freezer Parts	13
3.10	Sanitize Freezer & Freezer Parts	13
3.11	Assembly of Freezer	13
3.12	Routine Cleaning	14
3.13	Preventive Maintenance	14
3.14	Extended Storage	16
SECTION 4	REFRIGERATION SYSTEM	
4.1	Refrigeration System	17
4.2	Evaporators	18
4.3	Compressor Winding Test	18
4.4	Condensers	19
4.5	T.X.V.	20
4.6	T.X.V. Adjustment	20
4.7	T.X.V. Removal	20
4.8	T.X.V. Installation	21
4.9	Hopper	22
4.10	E.P.R. Valve Adjustment	22
4.11	E.P.R. Removal	23
4.12	E.P.R. Valve Installation	23
4.13	Capillary Tubes	24
4.14	Capillary Tube Removal	24
4.15	Capillary Tube Installation	24
4.16	Solenoid Valve	25
4.17	Solenoid Magnetic Coil Removal	26
4.18	Solenoid Magnetic Coil Installation	26

4.19	Liquid and Suction Line Solenoid Valve Removal	26
4.20	Liquid and Suction Line Solenoid Valve Installation	27
4.21	Water Valve	27
4.22	Water Valve Adjustment	27
4.23	Water Valve Removal	27
4.24	Water Valve Installation	28
4.25	Refrigerant Charge (All Models)	28

SECTION 5

CONTROLS

5.1	Control System	29
5.2	Power Board	29
5.3	Program Module	29
5.4	Plug-in Relays	36
5.5	Contactors	36
5.6	Spigot Switches	37
5.7	Spigot Switch Removal	37
5.8	Spigot Switch Installation	37
5.9	Front Door Interlock Switch	37
5.10	Front Door Interlock Removal	37
5.11	Front Door Interlock Switch Assembly	38
5.12	Touch Pad Switch Module	38
5.13	Touch Pad Switch Module Removal	38
5.14	Touch Pad Switch Module Assembly	39
5.15	Sensor	39
5.16	Sensor Removal	39
5.17	Sensor Installation	40
5.18	Preparation for Major Component Removal	40
5.19	Condenser Fan Motor and Lubrication	40
5.20	Condenser Fan Motor Removal	40
5.21	Condenser Fan Motor Installation	41
5.22	Drive Motor	41
5.23	Drive Motor Removal	41
5.24	Drive Motor Installation	42
5.25	Speed Reducer	43
5.26	Speed Reducer Removal	43
5.27	Speed Reducer Installation	43
5.28	Compressor	44
5.29	Compressor Removal	44
5.30	Compressor Installation	44
5.31	Final Assembly of Freezer	45

SECTION 6

TROUBLESHOOTING

6.1	Dispensing, Servability, and Overrun	48
6.2	Barrel and Hopper Mix Temperature Maintenance	49
6.3	Electro-Mechanical	50
6.4	Control Displayed Error Conditions	56

SECTION 7

REPLACEMENT PARTS

7.1	How To Order Parts	59
-----	--------------------------	----

LIST OF ILLUSTRATIONS

FIGURE	TITLE	PAGE
1	Model Endura/Futura 131 Freezer	1
2	Specifications	1
3	Warning Label Locations	3
4	Space and Ventilation Requirements	4
5	Installing Tray and Cover	4
6	Power Cord	4
7	Floor Stand	5
8	Power Cord Connection	5
9	Controls	7
10	Mix Inlet Regulator	9
11	Sanitizing Procedure	9
12	Clean Control	9
13	Sanitizing Hopper	9
14	Spigot Opened and Solution Draining	9
15	Dispensing Product	10
16	Removing Mix Inlet Regulator	11
17	Draining Mix	11
18	Auger Flight Wear and Front Auger Support Bushing Wear	11
19	Removing Front Door	12
20	Front Door Disassembly	12
21	Removing Auger Support	12
22	Auger Shafts	12
23	Removing "O" Ring	13
24	Exploded View of Auger	13
25	Exploded View of Front Door	14
26	Mix Inlet Regulator Installation	14
27	Refrigeration System	17
28	Compressor Terminal Cover	18
29	Compressor Connections	18
30	Ohmmeter and Connections	18
31	Electrical Box Cover Removal	19
32	Condenser and Filter	19
33	Condenser Inspection	20
34	T.X.V. (Thermostatic Expansion Valve)	20
35	Bulb Removal	21

36	T.X.V. Removal	21
37	Bulb Installation	22
38	Filter Drier	22
39	E.P.R. Schrader Access Fitting	22
40	E.P.R. Valve Adjustment	23
41	E.P.R. Valve and Lines	24
42	Filter Drier	24
43	Capillary Tube and Drive Assembly	25
44	Filter Drier	25
45	Power Cord	25
46	Pressure Gauges	26
47	Solenoid Replacement	26
48	Solenoid Coil Removal	26
49	Gauge Connection	27
50	Water Valve Adjustment	27
51	Power Board	30
52	Program Module	31
53	Membrane Switch Panel Display Board	32
54	Plug-in Relays	36
55	Spigot Switch Replacement	37
56	Interlock Switch Removal	38
57	Interlock Switch Assembly	38
58	Switch Module Removal	38
59	Electrical Box Removal	39
60	Cover Plate Removal	39
61	Foam Insulation Removal	39
62	Ty-raps Removal	40
63	Fan Motor Connections	41
64	Fan Bracket Removal	41
65	Drive Belt Removal	42
66	Drive Motor Wire Removal	42
67	Motor Pulley Adjustment	42
68	Belt Tension Adjustment	42
69	Speed Reducer Removal	43
70	Speed Reducer Adjustment	43
71	Belt Tension Adjustment	43
72	Compressor Cover Removal	44
73	Compressor Connections	44
74	Compressor Oil Test Kit	44
75	Filter Drier	45
76	O-Ring Identification Sheet	59

SECTION 1 INTRODUCTION

1.1 DESCRIPTION

The Stoelting Endura/Futura 131 counter freezer is gravity fed. The freezer is equipped with fully automatic controls to provide a uniform product. The freezer is designed to operate with almost any type of commercial soft serve or non-dairy mixes available, including ice milk, ice cream, yogurt, and frozen dietary desserts.

The freezer is designed to be used with both barrels in operation. If you desire to use one barrel only, the freezer must be cleaned, sanitized and filled with fresh mix daily. For more information call your authorized Stoelting Serviceperson.

This manual is designed to assist qualified service personnel and operators in the installation, operation and maintenance of the Stoelting Model Endura/Futura 131 gravity freezer.

Information Packet Location
Model Endura/Futura 131 - behind
Left Side Panel or behind the Front
Decorative Panel.



Figure 1. Model Endura/Futura 131 Freezer
(This freezer is mounted on the
optional Floor Stand.)

1.2 SPECIFICATIONS

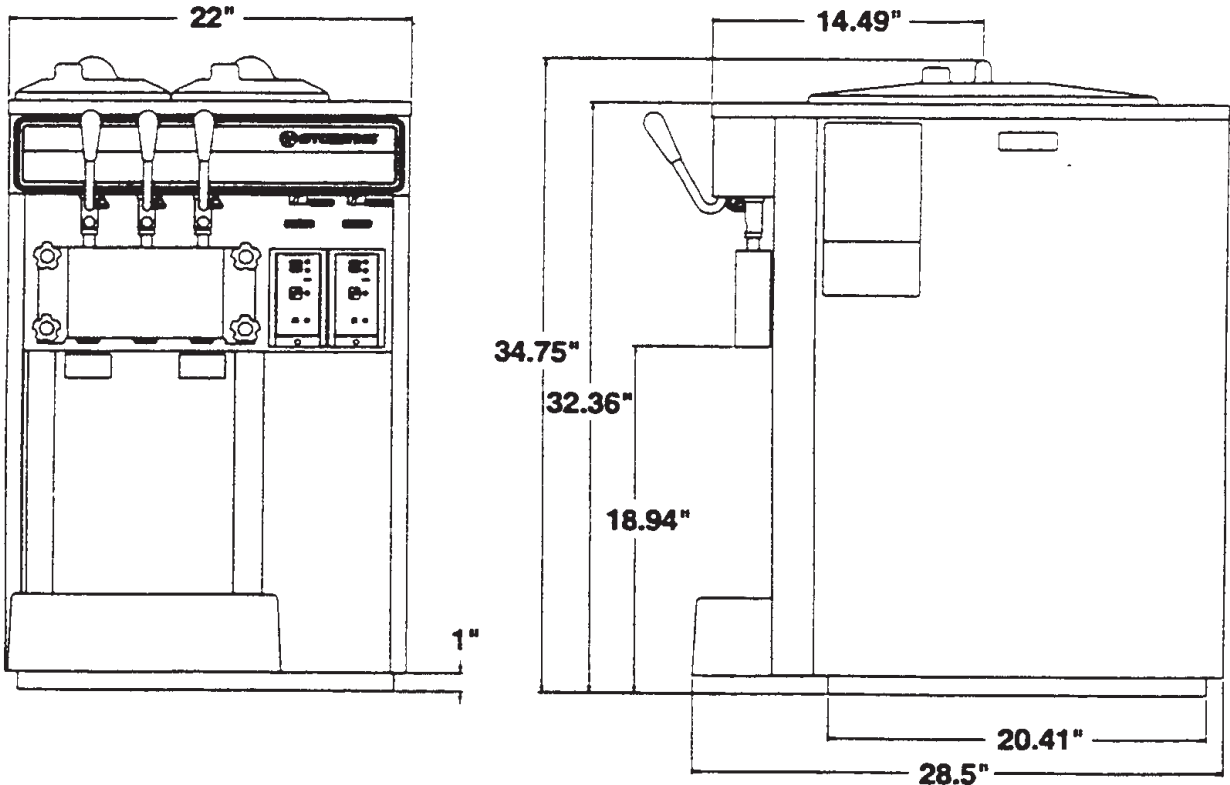

**MODEL ENDURA/FUTURA 131
COUNTER MODEL
GRAVITY FREEZER**

Dimensions:

Freezer: 22" (56 cm) wide x 28" (72 cm) deep x 34.75" (88 cm) high
 Crated: 28" (71 cm) wide x 35" (89 cm) deep x 38" (96 cm) high

Weight:

Freezer: 370 lbs. (168 kg) Crated: 450 lbs. (204 kg)

Electrical:

DESCRIPTION	ENDURA	FUTURA
Voltage AC	1ph 208-230V	1ph 208-230V
Total Running Amps	11.0	12.0
Drive Motors	3/4 HP each	3/4 HP each
Compressor	8,600 BTUh	12,000 BTUH

Use 20 amp HACR circuit breaker.

Automatic safeguard circuit built into electronic control - protects major freezer components under normal operating conditions.

Cooling

Air cooled requires minimum 3" air clearance on right and left hand side. No clearance needed in the rear.
 Water cooled required 3/8" I.D. water supply line and 3/8" I.D. drain line minimum.

Hopper

3 Gallons (11.35 liters) each refrigerated and insulated.

Refrigeration

Model	E131G	F131G
Refrigerant	R404A	R404A
Charge	A/C 32 oz. W/C 26 oz.	A/C 42 oz. W/C 26 oz.
Superheat out of the Evaporator	20 - 26 °F	7 - 16 °F
Suction Pressure	24 - 28 psig*	26 - 28 psig*
Head Pressure	225 - 235 psig	235 - 245 psig
Hopper Pressure	69 - 71 psig	69 - 71 psig

SECTION 2 INSTALLATION INSTRUCTIONS

2.1 SAFETY PRECAUTIONS

Do not attempt to operate the freezer until the safety precautions and operating instructions in this manual are read completely and are thoroughly understood.

Take notice of all warning labels on the freezer (Fig. 3). The labels have been put there to help maintain a safe working environment. The labels have been designed to withstand washing and cleaning. All labels must remain legible for the life of the freezer.

Labels should be checked periodically to be sure they can be recognized as warning labels.

If danger, warning or caution labels are needed, indicate the part number, type of label, location of label, and quantity required along with your address and mail to:

STOELTING, INC.
ATTENTION: Customer Service
502 Highway 67
Kiel, Wisconsin 53042-1600

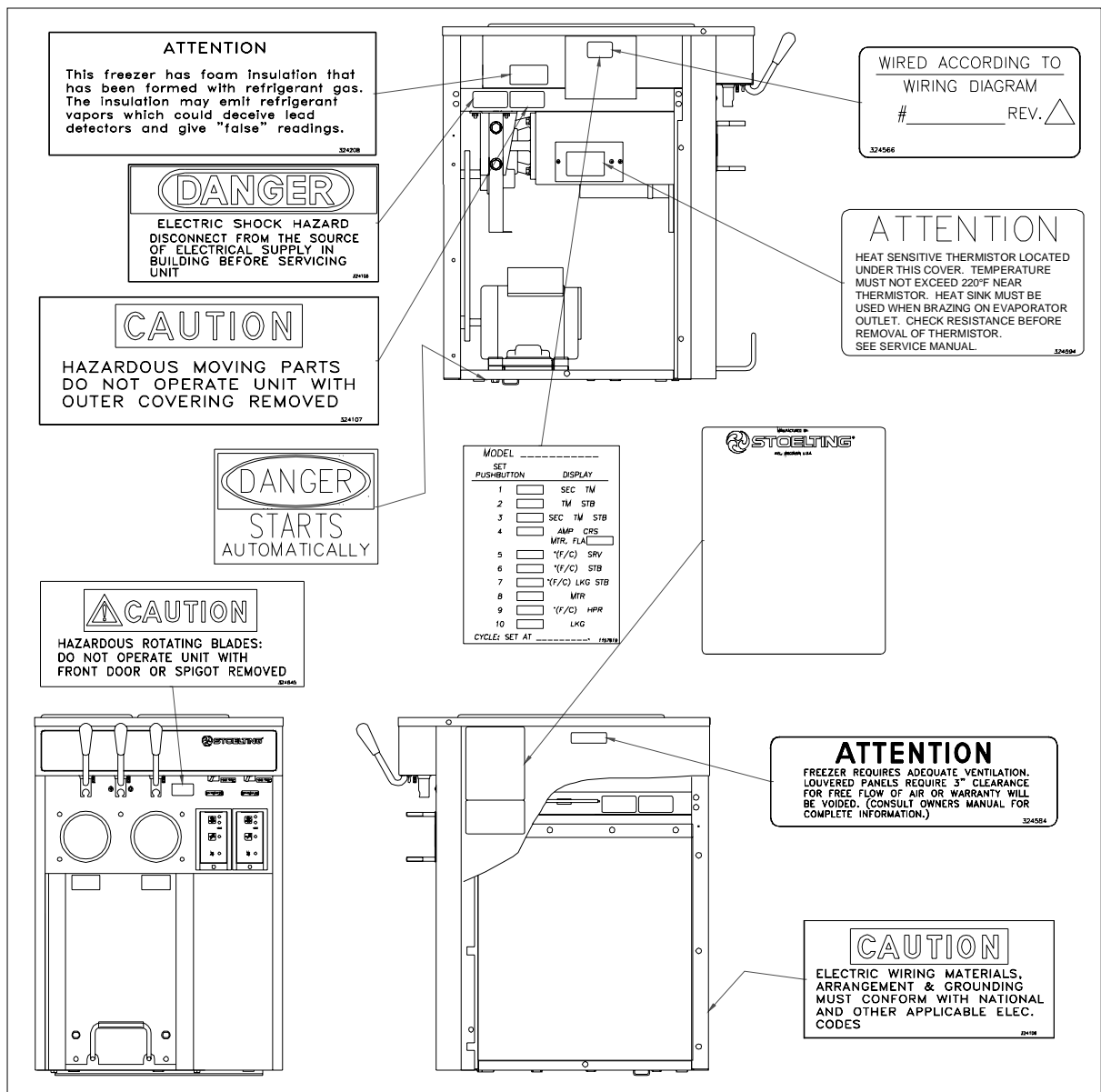

Fig. 3. Warning Label Locations

2.2 SHIPMENT AND TRANSIT

The freezer has been assembled, operated and inspected at the factory. Upon arrival at the final destination, the complete freezer must be checked for any damage which may have occurred during transit.

With the method of packaging used, the freezer should arrive in excellent condition. THE CARRIER IS RESPONSIBLE FOR ALL DAMAGE IN TRANSIT, WHETHER VISIBLE OR CONCEALED. Do not pay the freight bill until the freezer has been checked for damage. Have the carrier note any visible damage on the freight bill.

If concealed damaged and/or shortage is found later, advise the carrier within 10 days and request inspection. The customer must place claim for damages and/or shortages in shipment with the carrier. **Stoelting, Inc. cannot make any claims against the carrier.**

2.3 FREEZER INSTALLATION

Installation of the freezer involves moving the freezer close to its permanent location, removing all crating, setting in place, assembling parts, and cleaning.

A. Uncrate the freezer.

B. Accurate leveling is necessary for correct drainage of freezer barrel and to insure correct overrun. Place a spirit level on top of the freezer at each corner to check for level condition. If adjustment is necessary, level the freezer by turning the bottom part of each leg in or out. Then separate freezer base gasket and install with the seam to the back and the flat to the bottom. (Fig.4).

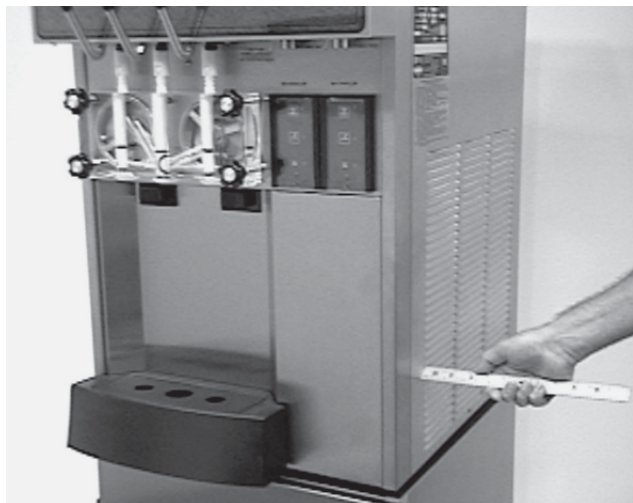

Fig. 4. Space and Ventilation Requirements

C. Air cooled freezers require correct ventilation. The right side of the freezer is the air intake and **must** have a 3" (7.5cm) clearance. Air discharges out of the left side of the unit and must have 3" (7.5cm) clearance. **Do not** obstruct the intake or discharge (Fig.4).



CAUTION

FAILURE TO PROVIDE ADEQUATE VENTILATION WILL VOID WARRANTY!

D. Place the OFF-ON switch in the OFF position.

E. Install the drip tray, drain trays, covers and other miscellaneous parts on the freezer. (Fig. 5)



Figure 5. Installing Tray and Insert

F. Connect the power cord. The plug is designed for 208 or 230 volt/20 amp duty. Check the nameplate on your freezer for proper supply. The unit must be connected to a properly grounded receptacle. The electrical cord furnished as part of the freezer has a three prong grounding type plug (Fig. 6). The use of an extension cord is not recommended. If one must be used, use one with a wire size 12 gauge or heavier with a ground wire. Do not use an adaptor to get around grounding requirement.



CAUTION

DO NOT ALTER OR DEFORM PLUG IN ANY WAY!



Figure 6. Power Cord

2.4 FLOOR STAND INSTALLATION

To install the E/F 131 on to the floor stand, follow the steps outlined below:

1. Uncrate the floor stand and place in an upright position.

NOTE

Detailed instructions are included with each floor stand.

2. Place a spirit level across the top of the stand to check for level condition, side to side and front to back. If adjustment is necessary, level the stand by turning the bottom part of each caster in or out, then tighten the lock nut, and lock caster.
3. Remove the four legs from the freezer and replace with the four leg adapters provided. Adapters must be fully tightened to the freezer.
4. Place the E/F131 freezer on the floor stand with the front of the freezer to the door end of the stand. Secure the freezer to the stand with the nuts and lock washers provided. Then separate freezer base gasket and install the seam to the back and the flat to the bottom (Fig. 7).



Fig. 7. Floor Stand

2.5 INSTALLING PERMANENT WIRING



ELECTRICAL TECHNICIANS MUST BE CONTINUOUSLY ALERT TO THE PRACTICE OF ALL NECESSARY SAFETY RULES AND PRECAUTIONS WHEN SERVICING THIS EQUIPMENT AS VOLTAGES ARE PRESENT WHICH CAN CAUSE SERIOUS OR FATAL INJURY.

ELECTRICAL WIRING MATERIALS, ARRANGEMENT AND GROUNDING MUST CONFORM WITH NATIONAL AND OTHER APPLICABLE ELECTRICAL CODES.

If permanent wiring is required by local codes, the following procedure must be performed:

- A. Remove the back panel.
- B. Disconnect the wires from the terminal block. Disconnect the green ground wire from the grounding stud.
- C. Remove the power cord.
- D. Install permanent wiring according to local code.
- E. Replace the back panel.

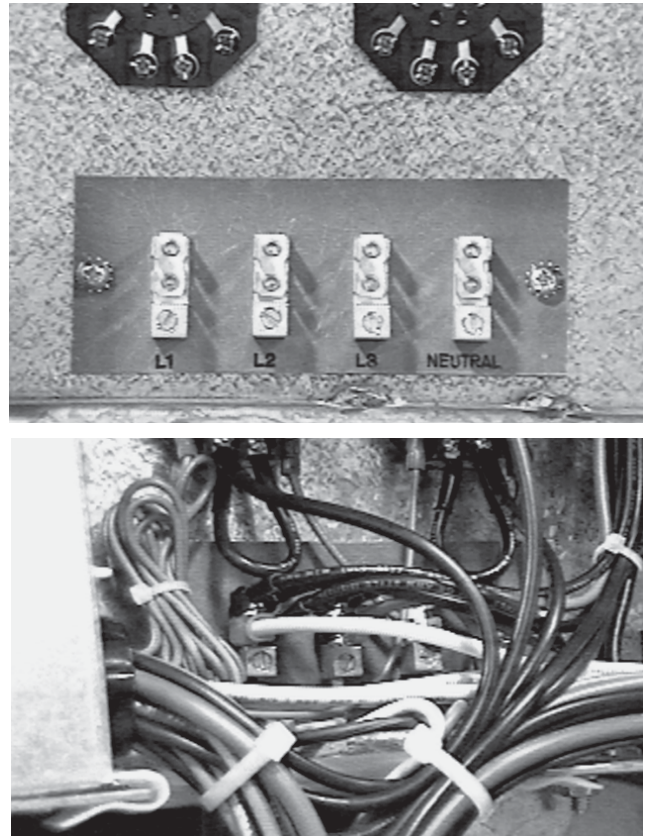

Figure 8. Power Cord Connection

SECTION 3 INITIAL SET-UP AND OPERATION

3.1 OPERATOR'S SAFETY PRECAUTIONS

SAFE OPERATION IS NOT AN ACCIDENT; Observe these rules:

- A. **Know the freezer.** Read and understand the Operating Instructions.
- B. **Notice all warning labels on the freezer.**
- C. **Wear proper clothing.** Avoid loose fitting garments, and remove watches, rings or jewelry which could cause a serious accident.
- D. **Maintain a clean work area.** Avoid accidents by cleaning up the area and keeping it clean.
- E. **Stay alert at all times.** Know which switch, push button or control you are about to use and what effect it is going to have.
- F. **Disconnect electrical cord for maintenance.** Never attempt to repair or perform maintenance on the freezer until the main electrical power has been disconnected.
- G. **Do not operate under unsafe operating conditions. Never operate the freezer if unusual or excessive noise or vibration occurs.**

3.2 OPERATION CONTROLS AND INDICATORS

Before operating the freezer, it is required that the operator know the function of each operating control. Refer to Figure 9 for the location of the operating controls on the freezer.

WARNING

THE CLEAN-OFF-ON SWITCH MUST BE PLACED IN THE OFF POSITION WHEN DISASSEMBLING FOR CLEANING OR SERVICING. THE FREEZER MUST BE DISCONNECTED FROM ELECTRICAL SUPPLY BEFORE REMOVING ANY ACCESS PANEL.

A. SPIGOT SWITCH

The SPIGOT switch will automatically actuate the auger drive and refrigeration systems when the spigot is opened to dispense product. When the spigot is closed, the drive motor and compressor will remain "on" until the product in the barrel reaches the proper consistency.

B. OFF-ON SWITCH

The OFF-ON switch is a two position toggle switch used to supply power to the control circuit. When the switch is in the OFF position, nothing will turn. When the switch is in the ON position, the freezer can be run in the freezing mode or cleaning mode. the freezer will be in the idle mode until a switch is activated.

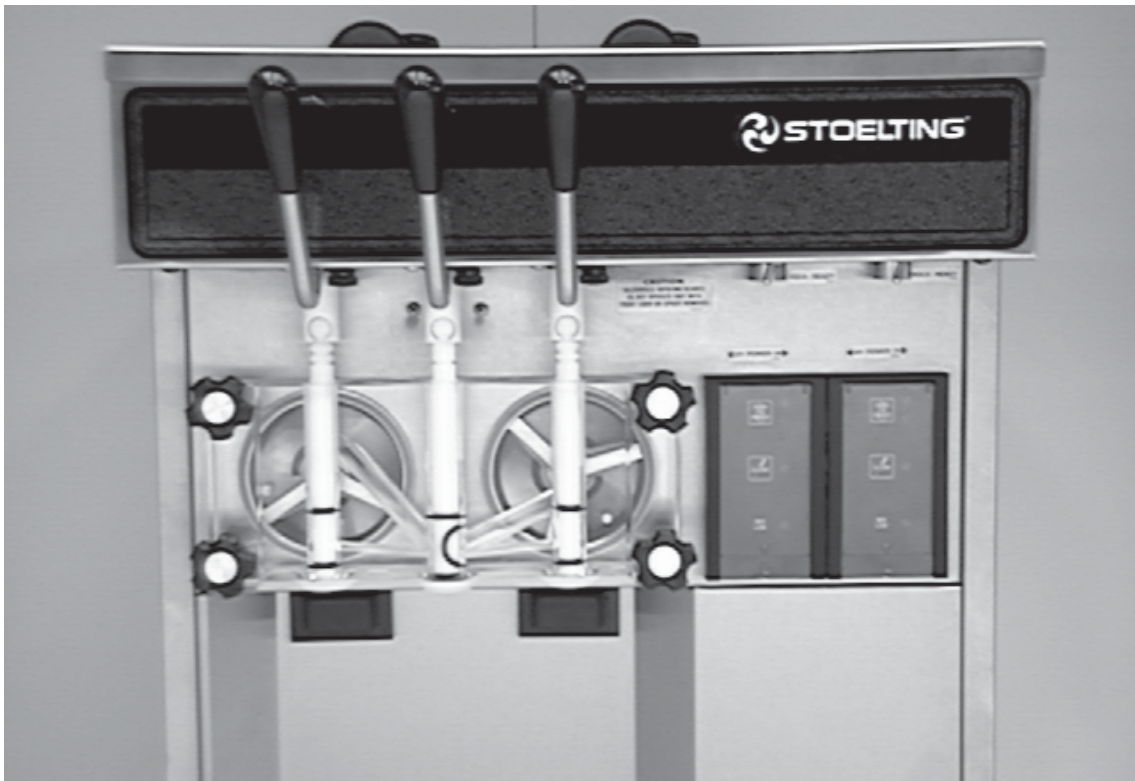

Figure 9. Controls

C. PUSH TO FREEZE SWITCH

The PUSH TO FREEZE switch is a "snap" switch used to start the freezing cycle. During initial freeze down, the OFF-ON switch is placed in the ON position. Then the PUSH TO FREEZE switch is pressed until the drive motor and compressor come "ON".

NOTE

After the gearmotor starts, there is a 3 second delay before the compressor starts.

During the normal operation, the red PUSH TO FREEZE switch light will illuminate after the freezer has been idle for the preset cycles. Before drawing product, press the red PUSH TO FREEZE switch if it is illuminated. Wait until the green light is illuminated before dispensing.

NOTE

If the freezer shuts off and the PUSH TO FREEZE light flashes, you have an error condition. Turn the OFF-ON switch to the OFF position, correct the problem and turn the freezer back on. (See Troubleshooting.)

D. GREEN LIGHT

The green light is used to indicate that the product has reached the proper consistency and is ready to be dispensed. The light begins to flash at 98% of consistency.

NOTE

If the PUSH TO FREEZE red light is illuminated, push the PUSH TO FREEZE switch and wait until the green light illuminates before dispensing.

E. CLEAN SWITCH

The CLEAN switch is a "snap" switch. When the switch is pushed the refrigeration system will be OFF and the auger will rotate for cleaning. When the switch is pushed again, the auger will stop and the CLEAN light will flash indicating the freezer is in the CLEAN mode. To exit the CLEAN mode turn the OFF-ON switch to the OFF position. If the freezer is left in CLEAN for more than 30 minutes or is pushed three times in ten seconds, it will go in error.

F. DRIVE MOTOR OVERLOAD

The internal drive motor overload will trip if the drive motor is overloaded. It will reset after approximately 10-12 minutes. If the drive motor continues to trip, refer to Section 4-Troubleshooting.

G. RED MIX LOW LENS

The red MIX LOW light is designed to alert the operator to a low mix condition. The lens will illuminate with approximately one gallon of mix in the hopper. When the MIX LOW lens is lit, refill hopper immediately.

NOTE

Failure to immediately refill hopper may result in operational problems.

H. HOLD READY SWITCH

The HOLD READY switch is a push button switch. When pushed in and held for 5 seconds, the hold ready mode will be activated. The product will remain ready to serve and the freezer will not go to idle. To return to normal operation push and hold for 5 seconds.

I. HIGH PRESSURE CUTOUT

The HIGH PRESSURE CUTOUT switch is a safety switch designed to protect the compressor from damage due to excessive head pressure. When tripped, the lever will be out, push in to reset.

J. DISPENSE RATE ADJUSTER

The DISPENSE RATE ADJUSTER limits the opening of the spigot.

To adjust product dispense rate, turn the adjusting knob clockwise for slower flow and counterclockwise for faster flow.

K. DOOR INTERLOCK SWITCH

When the door is securely fastened, the freezer will operate normally. When the door is removed, the drive and compressor will not run.

3.3 SANITIZING

Sanitizing must be done after the freezer is clean and just before the hopper is filled with mix. **Sanitizing the night before is not effective.** However, you should always clean the freezer and parts after using it.

WARNING

THE UNITED STATES DEPARTMENT OF AGRICULTURE AND THE FOOD AND DRUG ADMINISTRATION REQUIRE THAT ALL CLEANING AND SANITIZING SOLUTIONS USED WITH FOOD PROCESSING EQUIPMENT BE CERTIFIED FOR THIS USE.

When sanitizing the freezer, refer to local sanitary regulations for applicable codes and recommended sanitizing products and procedures. **The frequency of sanitizing must comply with local health regulations.** Mix sanitizer according to manufacturer's instructions to provide a 100 parts per million strength solution. Mix sanitizer in quantities of no less than 2 gallons (7.5 liters) of 120°F of water. Allow sanitizer to contact the surfaces to be sanitized for 5 minutes. Any sanitizer must be used only in accordance with the manufacturer's instructions.

CAUTION

PROLONGED CONTACT OF SANITIZER WITH FREEZER MAY CAUSE CORROSION OF STAINLESS STEEL PARTS.

In general, sanitizing may be conducted as follows:

- A. Push the mix inlet regulator into hopper with air inlet (long) tube toward the front of the freezer. (Fig. 10).



Figure 10. Mix Inlet Regulator

- B. Prepare 2 gallons (7.5 liters) of sanitizing solution following manufacturer's instructions. Pour into hopper with mix inlet regulator in place (Fig. 11).



Figure 11. Sanitizing Procedure

- C. Place the OFF-ON toggle switch in the ON position while pressing the CLEAN switch. Check for leaks.



Figure 12. Clean Control

- D. Clean sides of hopper, mix inlet regulator and underside of hopper cover using a sanitized soft bristle brush dipped in the sanitizing solution (Fig. 13).



Figure 13. Sanitizing Hopper

- E. After five minutes, place a bucket under the spigot and open spigot to drain sanitizing solution. When solution has drained, press the CLEAN snap switch to stop the auger. Allow the freezer barrel to drain completely (Fig. 14).



Figure 14. Spigot Opened and Solution Draining

3.4 FREEZE DOWN AND OPERATION

This section covers the recommended operating procedures to be followed for the safe operation of the freezer.

- A. Sanitize just prior to use.
- B. Place the OFF-ON switch in the OFF position.
- C. With spigots open, pour approximately 1 gallon (3.8 liters) of mix into the hopper. Allow the mix to flush out about 8 ounces (0.23 liters) of sanitizing solution and liquid mix. Close the spigot.

- D. Fill hopper with approximately 3 gallons (11.4 liters) of prechilled (40°F or 4°C) mix.

CAUTION

DO NOT OVERFILL THE HOPPER. MIX LEVEL MUST NOT BE HIGHER THAN 2 INCHES (5 CM) FROM THE TOP OF THE AIR INLET TUBE ON THE MIX INLET REGULATOR.

- E. The freezer barrel will automatically fill until it is about 1/2 full. If freezer barrel does not fill, check for obstruction in the mix inlet regulator. If freezer barrel fills over 1/2 full, indicated by low overrun, check for leaks at the mix inlet regulator "O" Ring or check if the mix inlet regulator was installed correctly or that the freezer is level.
- F. Place the OFF-ON switch in the ON position, then press the PUSH TO FREEZE switch until the freezer starts.

NOTE

After the gearmotor starts, there is a 3 second delay before the compressor starts.

- G. After about 6 to 10 minutes the freezer will shut off and the green lens will illuminate. The product will be ready to serve. Freeze down time may be longer for some frozen diet dessert mixes. High ambient temperatures may extend freeze down time.
- H. For normal dispensing, move the spigot handle fully open (Fig. 15).



Figure 15. Dispensing Product

CAUTION

REFRIGERATION IS AUTOMATICALLY ACTIVATED WHEN THE SPIGOT IS OPENED. CLOSE THE SPIGOT COMPLETELY AFTER DISPENSING.

- I. The freezer is designed to dispense the product at a reasonable draw rate. If the freezer is overdrawn, the result is a soft product or a product that will not dispense at all. If this should occur, allow the freezer to run for approximately 30 seconds before dispensing additional product. After a while the operator will sense or feel when the freezer is beginning to fall behind, and will slow down on the rate of draw so as not to exceed the capacity.
- J. **Do not** operate the freezer when the MIX LOW light is on or with less than 1-3/4" (4.4 cm) of mix in the hopper. Refill the hopper immediately.

NOTE

The freezer has a standby mode sometimes referred to as a sleep or energy conservation mode. When the freezer is not used, after a preset time, it will enter the standby mode and remain there until someone draws a product or pushes the push-to-freeze switch. In the standby mode, the freezer will keep the product below 45°F. Standby modes are not to be used in place of cleaning and sanitizing. Frequency of cleaning and sanitizing is determined by Federal, State, and local regulatory agencies.

3.5 MIX INFORMATION

Mix can vary considerably from one manufacturer to another. Differences in the amount of butterfat content and quantity and quality of other ingredients have a direct bearing on the finished frozen product. A change in freezer performance that cannot be explained by a technical problem may be related to the mix.

When changing from one type of mix to another such as yogurt to Vitari, you may have to change the mix inlet regulator and/or control settings. Please call your distributor for further information.

Proper product serving temperature varies from one manufacturer's mix to another. Mixes should provide a satisfactory product in the 18° to 20°F (-7° to -6°C) range.

When checking the temperature, stir the thermometer in the frozen product to read the true temperature.

Mix **does not** improve with age. Old mix, or mix that has been stored at too high a temperature, can result in a finished product that is less than satisfactory in taste and appearance. To retard bacteria growth in dairy based mixes, the best storage temperature range is between 36° to 40°F (2.2° to 4.4°C).

Some products tend to foam more than others. If excess foam should occur, skim the foam off with a sanitized utensil and discard. Periodically, stir the mix in the hopper with a sanitized utensil.

3.6 REMOVING MIX FROM THE FREEZER

To remove the mix from the freezer, refer to the following steps:

- A. Remove the mix inlet regulator from the hopper by pulling straight up (Fig.16).
- B. Place the OFF-ON rocker switch in the ON position and push the CLEAN switch to rotate the auger. Allow the mix to agitate in the freezer barrel until the mix has become a liquid, about 5 minutes.



Figure 16. Removing Mix Inlet Regulator

- C. Drain the liquid mix by opening the spigot. A bucket or container should be placed under the spigot to catch the liquid mix (Fig. 17).



Figure 17. Draining Mix

- D. Place the OFF-ON switch in the OFF position.

3.7 CLEANING THE FREEZER

NOTE

The frequency of cleaning the freezer and freezer parts must comply with local health regulations.

After the mix has been removed from the freezer, the freezer must be cleaned. To clean the freezer, refer to the following steps:

- A. Close the spigot and fill the hopper with 2 gallons (7.5 liters) of cold tap water.
- B. Place the OFF-ON switch in the ON position while pushing the CLEAN switch to rotate the auger.
- C. Allow the water to agitate for approximately five minutes.

NOTE

If freezer is left in CLEAN for more than 30 minutes, it will go to error.

- D. Open the spigot to drain the water. Remember to place a bucket or container under the spigot to catch the water. When the water has drained, turn the OFF-ON switch to the OFF position. Allow the freezer barrel to drain completely.
- E. Repeat steps A through D using a mild detergent solution.

3.8 DISASSEMBLY OF FREEZER PARTS

CAUTION

PLACE THE OFF-ON TOGGLE SWITCH IN THE OFF POSITION BEFORE DISASSEMBLING FOR CLEANING OR SERVICING.

Inspection for worn or broken parts should be made at every disassembly of the freezer for cleaning or other purposes. All worn or broken parts should be replaced to ensure safety to both the operator and the customer and to maintain good freezer performance and a quality product. Two normal wear areas are the auger flights and front auger support bushing (Fig. 18). Frequency of cleaning must comply with the local health regulations.

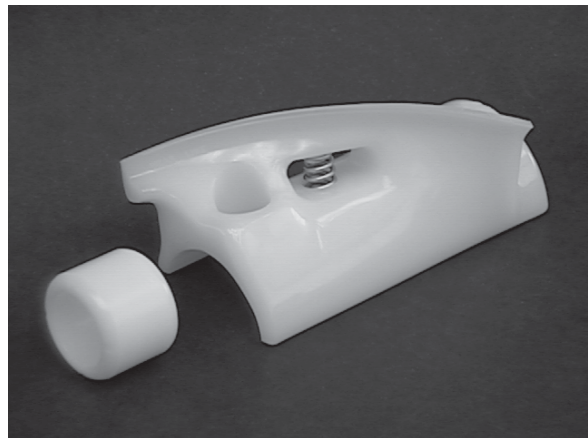

Figure 18. Auger Flight Wear and Front Auger Support Bushing Wear

To disassemble the freezer, refer to the following steps:

- A. Remove the mix inlet regulator from the hopper by pulling straight up.
- B. Remove the front door by turning off the circular knobs and then pulling the front door off the studs (Fig.19).



Figure 19. Removing Front Door

- C. Remove the rosette caps from the front door. Push the spigot body through the bottom of the front door and remove. (Fig. 20).

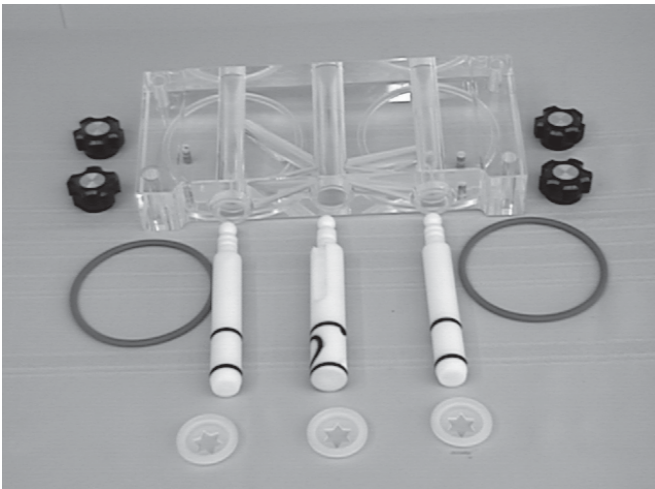

Figure 20. Front Door Disassembly

- D. Remove the front auger supports and bushings (Fig. 21).

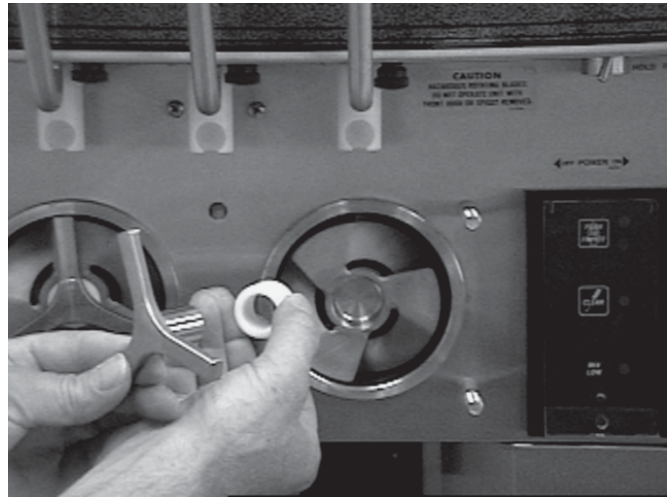

Figure 21. Removing Auger Supports

- E. Remove the auger assemblies from the freezer. Pull the augers out of the freezer barrel slowly. As the augers are being pulled out, carefully remove each of the plastic flights with springs.
- F. Keep the rear of the auger shafts tipped up once they are clear of the freezer barrels to avoid dropping rear seals (Fig. 22.)

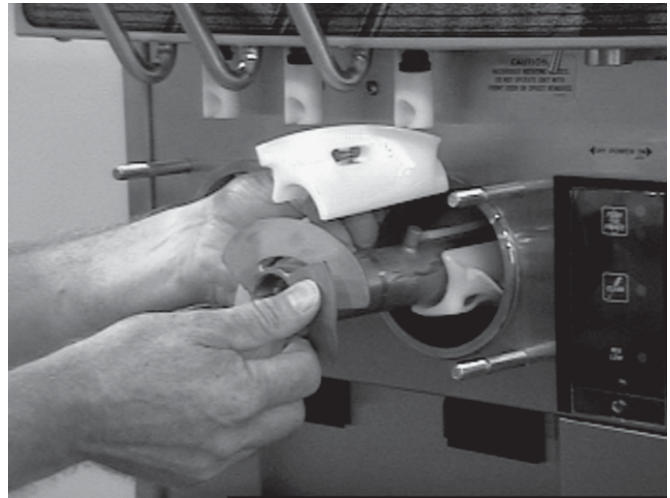

Figure 22. Auger Shafts

- G. Wipe socket lubricant from the drive end (rear) of the auger with a cloth or paper towel.
- H. Remove the rear seals.
- I. Remove all "O" Rings from parts by first wiping off the lubricant using a clean paper towel. Then squeeze the "O" Ring upward with a dry cloth (Fig. 23). When a loop is formed, roll out of the "O" Ring groove.



Figure 23. Removing "O" Ring

WARNING

DO NOT USE ANY TYPE OF SHARP OBJECT TO REMOVE THE O-RINGS.

3.9 CLEANING THE FREEZER PARTS

Place all loose parts in a pan or container and take to the wash sink for cleaning. To clean freezer parts refer to the following steps:

- A. Place all parts in warm mild detergent water and clean with brushes provided. Rinse all parts with clean hot water.

CAUTION

DO NOT DAMAGE PARTS BY DROPPING OR ROUGH HANDLING.

- B. Wash the hopper and freezer barrel with warm detergent water and brushes provided.
- C. Clean the rear seal surfaces from the inside of the freezer barrel with warm detergent water.

NOTE

Clean the auger drive socket located inside the barrel at the rear seal area. Use clean cloth or paper towel for this purpose.

- D. Clean the drip tray and insert with a soap solution. Rinse with clean hot water.

3.10 SANITIZE FREEZER AND FREEZER PARTS

- A. Use a sanitizer mixed according to manufacturer's instructions to provide a 100 parts per million strength solution. Mix sanitizer in quantities of no less than 2 gallons (7.5 liters) of 120°F water. Allow the sanitizer to contact the surfaces to be sanitized for 5 minutes. Any sanitizer must be used only in accordance with the manufacturer's instructions.

- B. Place all parts in the sanitizing solution, then remove and let air dry.
- C. Using this sanitizing solution and the large barrel brush provided, sanitize the rear of the barrel and drive area by dipping the brush in the sanitizing solution and brushing the rear of the barrel.

3.11 ASSEMBLY OF FREEZER

To assemble the freezer parts, refer to the following steps:

NOTE

Petrol-Gel sanitary lubricant or equivalent must be used when lubrication of parts is specified.

NOTE

The United States Department of Agriculture and Food and Drug Administration require that lubricants used on food processing equipment be certified for this use. Use lubricants only in accordance with the manufacturer's instructions.

- A. Assemble all o-rings onto parts dry, **without lubrication**. Then apply a thin film of sanitary lubrication to exposed surfaces of the "O" Rings. Apply a thin film of sanitary lubricant to metal part of rear seal. Also apply a thin film of sanitary lubricant inside the hole of the front of the auger.
- B. Assemble the rear seals onto the augers with the large end to the rear. Be sure the "O" Ring is in place before installing the rear seal.
- C. Lubricate the inside of the auger drive sockets (rear) with a small amount of white socket lubricant. A small container of socket lubricant is shipped with the freezer.
- D. Screw the springs onto the studs in plastic flights. **Springs must be screwed into the flights completely** to provide compression (Fig. 24).

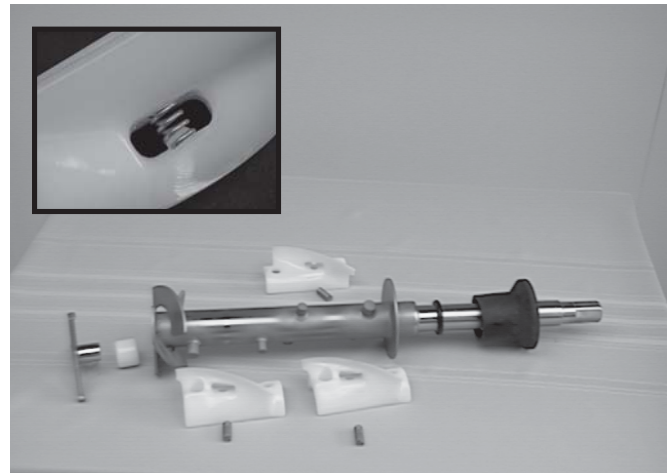

Figure 24. Exploded View of Auger

CAUTION

DO NOT PLACE THE MIX INLET REGULATOR INTO THE HOPPER BEFORE INSTALLING THE AUGER.

- E. Install the two plastic flights onto rear of the auger and insert part way into freezer barrel.
- F. Install the third plastic flight, push the auger into the freezer barrel and rotate slowly until the auger engages the drive socket.
- G. Install the auger support and bearing into the front of the augers with one leg of the support at 9 o'clock.

NOTE

Apply a small amount of Petro-Gel to the surface of the cam on the spigot handle prior to assembly of handle to the spigot body.

- H. Install the spigot bodies with "O" Rings into the front door from the bottom (Fig.25). Push straight up until the spigots are in place. Install rosette caps.

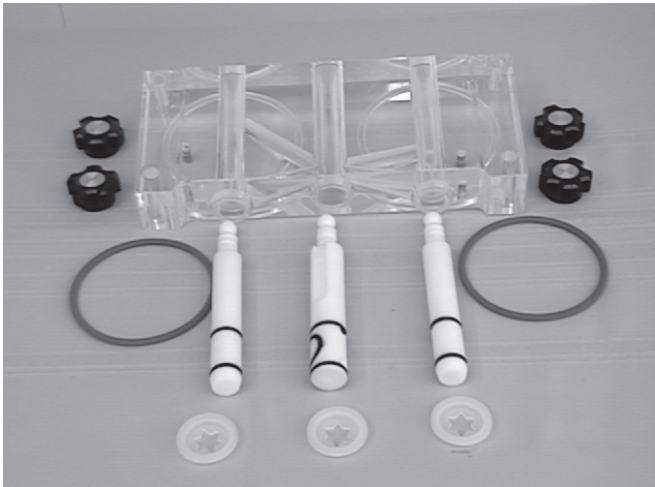

Figure 25. Exploded View of Front Door

- I. Install the front door on the freezer.
- J. Install the circular knobs on the freezer studs.

CAUTION

FINGER TIGHTEN THE CIRCULAR KNOBS EVENLY. DO NOT OVERTIGHTEN KNOBS.

Look for the proper seal between the freezer barrel, "O" Ring, and front door.

- K. Install the mix air regulator into the freezer with the air tube to the front of the freezer. (Fig. 26).

NOTE

Refer to page 3-2, section 3.3, for sanitizing the assembled freezer before filling with mix.



Figure 26. Install Mix Inlet Regulators

3.12 ROUTINE CLEANING

To remove spilled or dried mix from the freezer exterior, simply wash in the direction of the finish with warm soapy water and wipe dry. **Do not** use highly abrasive materials as they will mar the finish.

3.13 PREVENTIVE MAINTENANCE

It is recommended that a maintenance schedule be followed to keep the freezer clean and operating properly.

A. Cleaning and Sanitizing Information

Soft serve freezers require special consideration when it comes to food safety and proper cleaning and sanitizing.

The following information has been compiled by Purdy Products Company, makers of Stera-Sheen Green Label Cleaner/Sanitizer and specifically covers issues for cleaning and sanitizing frozen dessert machines. This information is meant to *supplement* a comprehensive food safety program.

Soil Materials Associated with Frozen Dessert Machines

MILKFAT/BUTTERFAT – As components of ice-cream/frozen custard mix, these soils will accumulate on the interior surfaces of the machine and its parts. Fats are difficult to remove and help attribute to milkstone build-up.

MILKSTONE – Is a white/gray film that forms on equipment and utensils that come in contact with dairy products. These films will accumulate slowly on surfaces because of ineffective cleaning, use of hard water, or both. Milkstone is usually a porous deposit, which will harbor microbial contaminants and eventually defy sanitizing efforts.

Once milkstone has formed, it is very difficult to remove. Without using the correct product and procedure, it is nearly impossible to remove a thick layer of milkstone.

(NOTE: general-purpose cleaners DO NOT remove milkstone.) ***This can lead to high bacteria counts and a food safety dilemma.***

IT IS BEST TO CONTROL MILKSTONE ON A DAILY BASIS BEFORE IT CAN BECOME A SIGNIFICANT FOOD SAFETY PROBLEM.

In addition to food safety, milkstone can cause premature wear to machine parts which can add to costs for replacement parts or possibly more expensive repairs if worn machine parts are not replaced once they have become excessively worn.

Important Differences Between Cleaning and Sanitizing

CLEANING vs. SANITIZING

It is important to distinguish between cleaning and sanitizing. Although these terms may sound synonymous, they are not. BOTH are required for adequate food safety and proper machine maintenance.

CLEANING

- Is the removal of soil materials from a surface.
- Is a prerequisite for effective sanitizing.

NOTE

An UNCLEAN surface will harbor bacteria that can defy sanitizing efforts.

Bacteria can develop and resist sanitizing efforts within a layer of soil material (milkstone). ***Thorough cleaning procedures that involve milkstone removal are critical for operators of frozen dessert machines.***

SANITIZING

- Kills bacteria.
- Can be effective on clean surfaces only.
- **DOES NOT** clean or remove milkstone.

NOTE

Using a SANTITIZER on an unclean surface will not guarantee a clean and safe frozen dessert machine.

Proper Daily Maintenance: The Only Way to Assure Food Safety and Product Quality

Proper daily maintenance can involve a wide variety of products and procedures. Overall, the products and procedures fall into three separate categories. *(Please note that this is a brief overview intended for informational purposes only.)*

1. **CLEANING** – This involves draining mix from the freezer barrel and rinsing the machine with water. Next, a cleaner is run through the machine. Then, the machine is disassembled and removable parts are taken to the sink for cleaning.
2. **MILKSTONE REMOVAL** – Since almost all cleaners do not have the ability to remove milkstone, the use of a delimer becomes necessary. Although this procedure may not be needed on a daily basis, it will usually follow the cleaning procedure. It requires letting a delimer solution soak in the machine for an extended period of time. Individual parts are also soaked in a deliming solution for an extended period of time (more about delimers in *Additional Information*).
3. **SANITIZING** – After the machine has been cleaned and contains no milkstone, the machine is reassembled. Then a FDA-approved sanitizing solution is run through the machine to kill bacteria. The machine is then ready for food preparation.

As a recommended cleaner and sanitizer for your frozen dessert machine, STERA-SHEEN has proven to be one of the best daily maintenance products for:

- **CLEANING** – Thorough removal of all solids including butterfat and milk fat.
- **MILKSTONE REMOVAL** – Complete removal of milkstone.
- **SANITIZING** – FDA-approved no rinse sanitizer for food contact surfaces.

Additional Information

THE USE OF DELIMERS

A delimer is a strong acid that has the ability to dissolve milkstone. This type of chemical may become necessary once high levels of milkstone have developed. While these products are very effective for removing HIGH levels of milkstone, they are not ideal for two reasons:

1. **PRODUCT SAFETY** – Strong acids are dangerous chemicals and handling them requires safety.
2. **MACHINE DAMAGE** – Strong acids will attack metal and rubber causing premature wear of parts. The use of a delimer needs to be closely monitored to avoid damage to machine surfaces and parts.

With proper daily use of STERA-SHEEN or it's equivalent, there is *no need* for the use of a *DELIMER*.

DO NOT USE BLEACH

- BLEACH HAS ABSOLUTELY **NO** CLEANING PROPERTIES.
- BLEACH IS CORROSIVE. It can and will damage components of the machine causing premature wear and metal corrosion.

GENERAL PURPOSE CLEANERS

General purpose cleaners do not have the ability to remove milkstone. Milkstone will become a problem *if not remedied* with additional products and procedures.

THE USE OF CHLORINE TEST STRIPS

“Test strips” are used to determine concentrations of active chlorine in sanitizing solutions. To use the strips, tear off a small portion and submerge it into the sanitizing solution. Then, compare the color change to the color key on the side of the test strip dispenser to determine the approximate chlorine concentration.

The ideal concentration of chlorine needs to be 100 ppm (as stated by the FDA).

NOTE

Follow the directions on the container for proper concentration.

There are two main factors that contribute to falling chlorine concentrations in a sanitizing solution.

1. **PRODUCT USE** – As the chlorine in the solution is being used, chlorine concentrations fall.
2. **TIME** – As time passes, small amounts of chlorine “evaporate” from the solution. (That is why you can smell it.)

Sanitizing solutions *should not* be allowed to fall below 100 ppm chlorine. New solutions should be mixed once old solutions become ineffective.

WARNING

NEVER ATTEMPT TO REPAIR OR PERFORM MAINTENANCE ON FREEZER UNTIL THE MAIN ELECTRICAL POWER HAS BEEN DISCONNECTED.

B. DAILY

1. The exterior should be kept clean at all times to preserve the lustre of the stainless steel. A mild alkaline cleaner is recommended. Use a soft cloth or sponge to apply the cleaner.

CAUTION

DO NOT USE ACID CLEANERS, STRONG CAUSTIC COMPOUNDS OR ABRASIVE MATERIALS TO CLEAN ANY PART OF THE FREEZER EXTERIOR OR PLASTIC PARTS.

C. WEEKLY

1. Check "O" Rings and rear seal for excessive wear and replace if necessary.
2. Remove the drip tray by gently lifting up to disengage from the support and pulling out. Clean behind the drip tray and front of the freezer with a soap solution.

SECTION 4 REFRIGERATION SYSTEM



WARNING

BOTH SUCTION SIDE SOLENOIDS MUST BE ACTIVATED FOR PROPER PURGING OF SYSTEM. USE POWER CORD PART NUMBER 430119 OR EQUIVALENT FOR DIRECT CONNECTION.

4.1 REFRIGERATION SYSTEM

The refrigeration system (Fig.27) is a dual-purpose system.

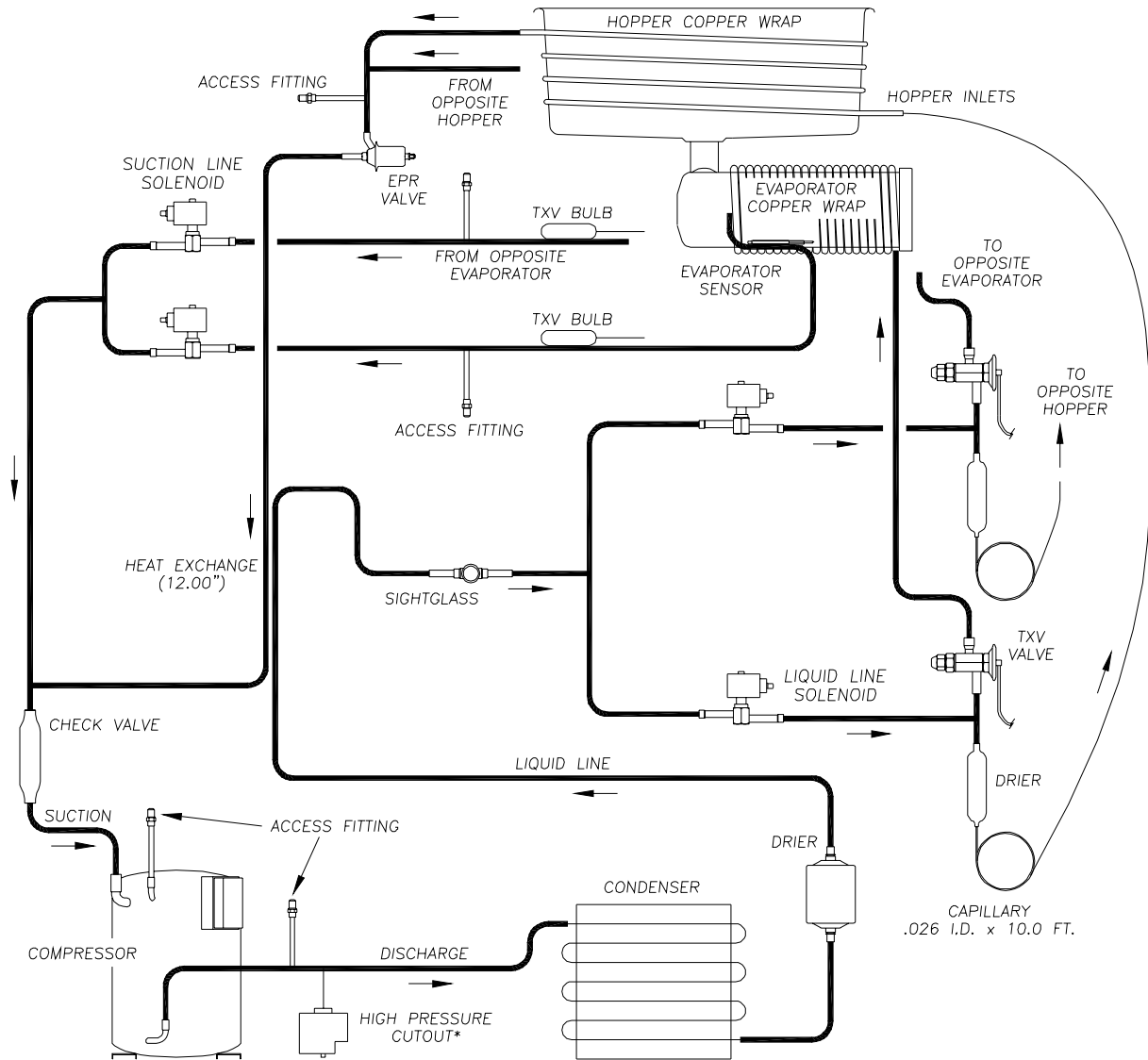

Figure 27. Refrigeration System

The system is designed to operate both the hopper and evaporator simultaneously at different temperatures. The system is designed for efficient use with R404A as the refrigerant. The proper charge is indicated on the nameplate and on the compressor.

The compressor has an internal high-pressure bypass. This bypass eliminates the need for a high-pressure cutout switch on air-cooled models. Water-cooled models must have a high-pressure cutout switch.

4.2 EVAPORATORS

The hopper and barrel evaporators are wrapped with copper tubing and thermomastic, then insulated with foam insulation. The compressor is designed specifically for use with R404A.

4.3 COMPRESSOR WINDING TEST

To test the compressor motor windings for possible problems, perform the following steps:



Warning

DISCONNECT FREEZER FROM ELECTRICAL SUPPLY SOURCE BEFORE SERVICING.

1. Remove the Phillips head screw from the bottom of the left side panel and slide the side panel down and out.
2. Remove the compressor terminal cover by inserting a standard screwdriver between the terminal cover and compressor cover frame: then, gently pry off from the right side, then the left (Figure 28).

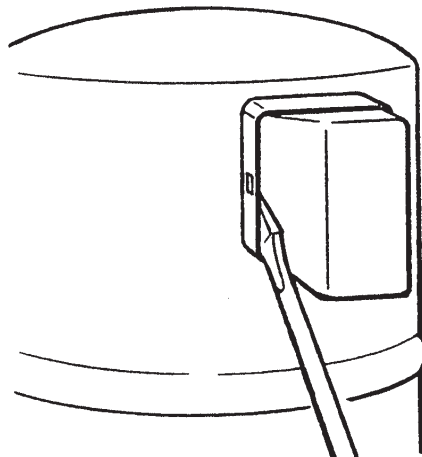

Figure 28. Compressor Terminal Cover

3. Remove wires C, R, and S at compressor. Refer to Figure 29 for compressor connections.



Figure 29. Compressor Connections

NOTE

The following values are average for most Copeland compressors. For exact values or other brands, consult the manufacturer's service data manual.

4. Connect an ohmmeter to terminals C and R. Resistance through the run winding should be 3.12 to 3.60 ohms with the ohmmeter set at ohms x 1 (Figure 30).

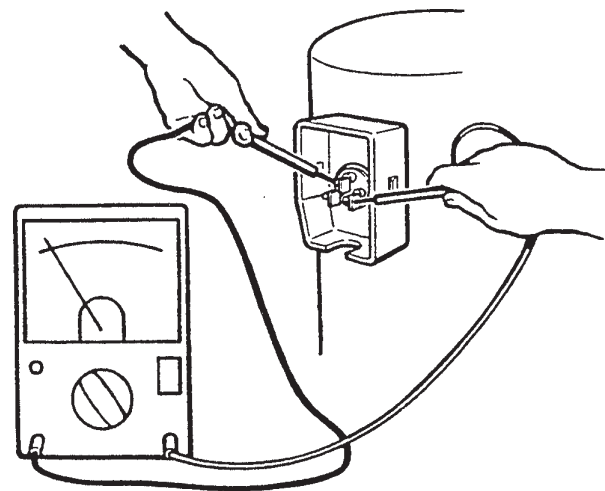

Figure 30. Ohmmeter and Connections

5. Connect the ohmmeter to terminals C and S. Resistance through the start winding should be 7.77 to 8.93 ohms with the ohmmeter set at ohms x 1.
6. To check if windings are shorted to ground, connect one ohmmeter lead to a bare metal part on the compressor, such as any copper line leading to or from the compressor and checking terminals C, R, and S.

NOTE

The compressor is equipped with an internal overload protector. If the compressor is warm and ohmmeter reads indicate an open winding, and allow up to one hour for the overload to reset.

To access the compressor starting components, remove the Phillips head screw from the bottom of the right side panel and remove the panel by pulling down and out. Then, remove the cover from the lower electrical box located just above the condenser on the right side of the freezer (Figure 31).

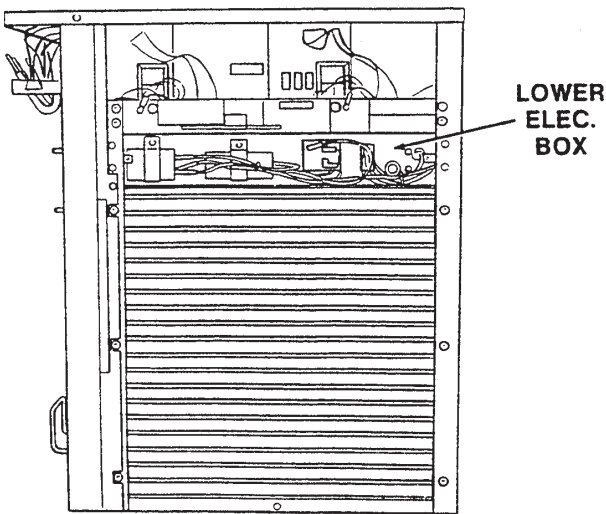

Figure 31. Electrical Box Cover Removal

4.4 CONDENSERS

The air-cooled condenser is a copper tube and aluminum fin type. Condensing is totally dependent upon airflow. A plugged condenser filter, condenser, or restrictions in the louvered panel will restrict airflow. This will lower the capacity of the system and damage the compressor.

The condenser must be kept clean of dirt and grease. The freezer must have a minimum of 3" (7.5 cm) of

ventilation on the right and left sides of the unit for free flow of air (Figure 32). Make sure the freezer is not pulling over 100° F (37° C) air from other equipment in the area.

The water-cooled condenser is a tube and shell type. The condenser needs a cool, clean supply of water to properly cool the freezer, Inlet and discharge lines must be 3/8" I.D. minimum.

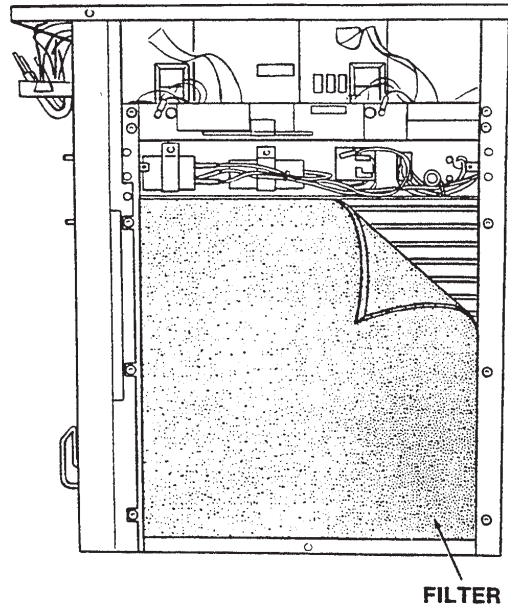

Figure 32. Condenser and Filter

The condenser and condenser filter require periodic cleaning. To clean, refer to the following procedures.



DISCONNECT FREEZER FROM ELECTRICAL SUPPLY SOURCE BEFORE SERVICING.

1. Remove the Phillips head screw from the bottom of the right side panel, and then slide the panels down and out.
2. To remove the condenser filter, grasp the top and pull off. Visually inspect for dirt. If the filter is dirty, shake or brush excess dirt off the filter and wash in warm, soapy water. Once the filter is clean rinse thoroughly in warm, clear water and shake dry, taking care not to damage the filter in any way.
3. Visually inspect the condenser for dirt by shining a light through the coil from the back (inside) of the condenser (Figure 33).

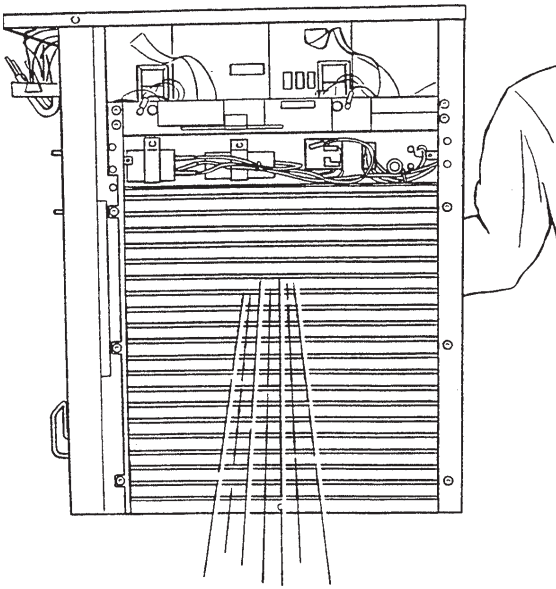

Figure 33. Condenser Inspection

4. If the condenser is dirty, place a wet towel over the front (outside) of the condenser.
5. Using compressed air or a CO₂ tank, blow out the dirt from the back (inside) of the condenser. Most of the dirt will cling to the wet towel.

NOTE

This procedure will result in a very loud noise.

6. An alternative method of cleaning the condenser is to use a condenser brush and vacuum.

NOTE

If the condenser is not kept clean, loss of refrigeration efficiency will result; causing extended run time or soft product consistency.

Water-cooled condensers need an unrestricted supply of cold, clean water.

4.5 T.X.V.

A T.X.V. (Thermostatic Expansion Valve) (Figure 34) is used to meter the refrigerant to the evaporator. The self-regulating T.X.V. is preset at the factory.

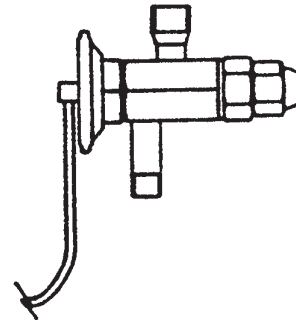

Figure 34. T.X.V. (Thermostatic Expansion Valve)

4.6 T.X.V. ADJUSTMENT

T.X.V. adjustment is not recommended. Any attempt to adjust the T.X.V. will cause the freezer to be totally out of calibration.

4.7 T.X.V. REMOVAL



CAUTION

IF A T.X.V. REPLACEMENT IS NEEDED, A HEATSINK (WET CLOTH) MUST BE USED TO PREVENT DAMAGE TO THE VALVE.



WARNING

DISCONNECT FREEZER FROM ELECTRICAL SUPPLY SOURCE BEFORE SERVICING.

1. Remove the two Phillips head screws from the bottom of the front and side panels then slide the panels down and out (Figure 35).
2. Remove the bulb from the suction line exiting from the evaporator (Figure 35).

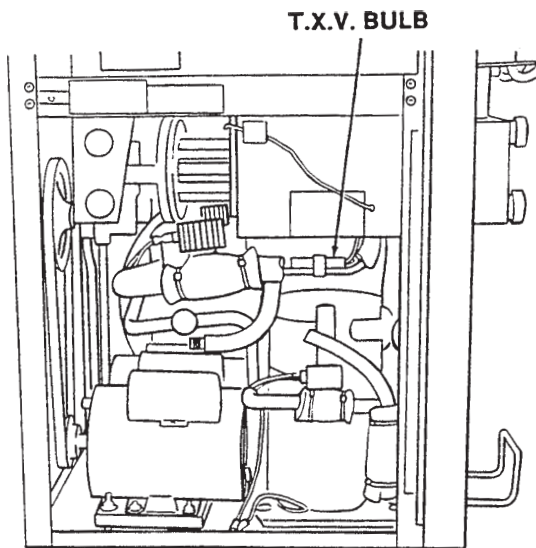

Figure 35. Bulb Removal

3. Recover the refrigerant charge, and then leave a port open to prevent pressure buildup when applying heat.



WARNING

BOTH SUCTION SIDE SOLENOIDS MUST BE ACTIVATED FOR PROPER PURGING OF SYSTEM. USE POWER CORD PART NO. 430119 OR EQUIVALENT FOR DIRECT CONNECTION.

4. Remove any insulation from the T.X.V. and immediate surrounding lines.
5. Remove or push back any foam insulation from surrounding lines.
6. Apply a heatsink (wet cloth) to the valve dome (Figure 36).

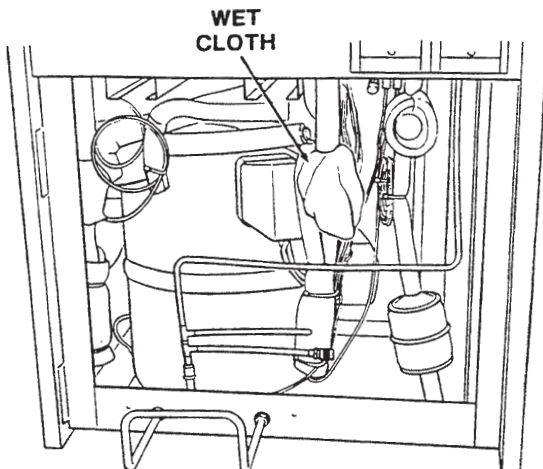

Figure 36. T.X.V. Removal

7. Unsweat the suction line and liquid line from the T.X.V. and remove.

4.8 T.X.V. INSTALLATION

To replace the T.X.V., perform the following procedures:



CAUTION

WHEN PLACING THE T.X.V., A HEATSINK (WET CLOTH) MUST BE USED TO PREVENT DAMAGE TO THE VALVE.

1. Position the T.X.V. with heatsink so the liquid line and suction line correspond with the proper valve ports.
2. Braze the liquid line and suction line to the T.X.V. by using the appropriate brazing material.
3. Remove the heatsink from the T.X.V.
4. Replace any foam insulation to the surrounding lines.
5. Replace any insulation to the T.X.V. and surrounding areas.

NOTE

The liquid line from the condenser is bonded to the suction line to provide a heat exchange to help protect the compressor from liquid slugging. This also assures that sub-cooled liquid is being supplied to the expansion devices.

6. Install the bulb on the suction line exiting the evaporator (Figure 37). The T.X.V. bulb should always be mounted on the top of the horizontal line. Good contact between the bulb and suction line is necessary for proper operation of the valve. The bulb must also be well insulated.

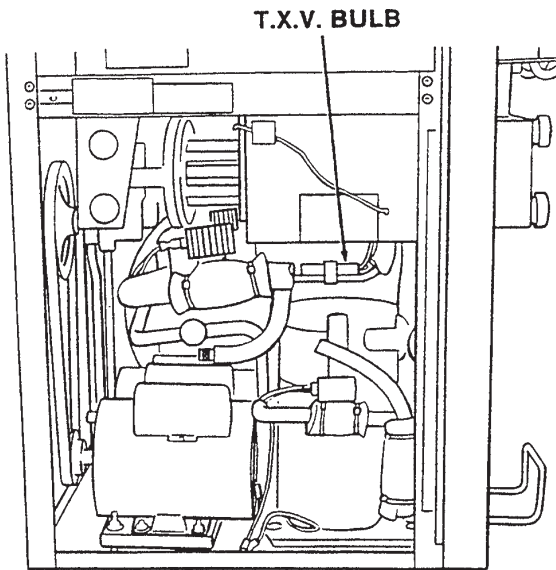

Figure 37. Bulb Installation

7. Replace filter drier using the appropriate brazing material (Figure 38).

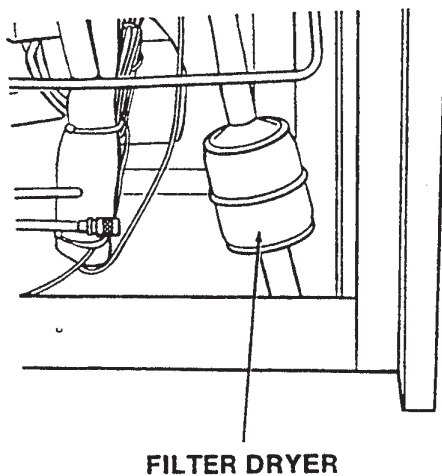

Figure 38. Filter Dryer

8. Once the T.X.V. and filter drier are installed, the refrigeration system must be leaked checked, purged and evacuated to 500 microns of mercury or less at either barrel outlet access fitting proceeding suction line solenoid valves.

4.9 HOPPER

A parallel refrigeration circuit feeds the hoppers. A capillary tube is used to meter the refrigerant to each hopper. An E.P.R. (Evaporator Pressure Regulating) valve is used to control the refrigerant flow at the outlets. The E.P.R. valve controls the hopper pressure so during heavy dispensing periods, hopper temperatures will not drop and freeze the mix in the hopper. The adjustable E.P.R. valve is preset at the factory. If the hopper temperature is too cold or too warm, an E.P.R. valve adjustment may be necessary.

4.10 E.P.R. VALVE ADJUSTMENT

To adjust the E.P.R. valve, refer to the following procedures:

1. Remove the Phillips head screws from the bottom of the front panel and remove the panel by sliding down and out.
2. Remove the cap from the E.P.R. Schrader access fitting (Figure 39).

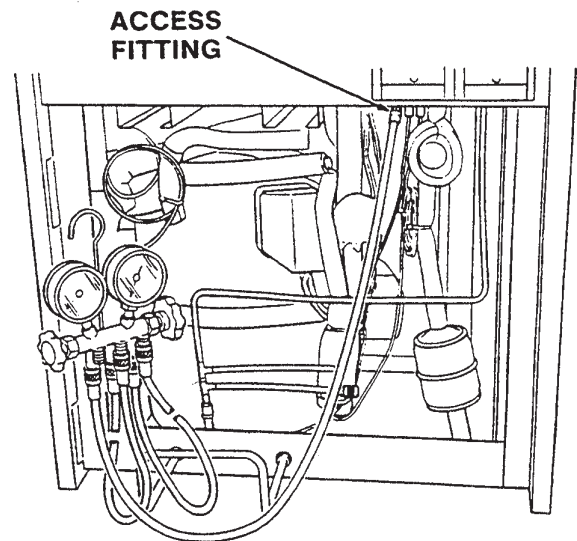

Figure 39. E.P.R. Schrader Access Fitting

3. Install a 0-100 P.S.I.G. gauge onto the E.P.R. Schrader access fitting.
4. Start the refrigeration cycle and read the pressure.

NOTE

The ideal E.P.R. valve setting (69-71 P.S.I.G.) will not allow mix to freeze to the walls of the hopper.

5. If the pressure gauge reading does not fall between the 69-71 P.S.I.G. parameters, proceed with the following steps.
6. Remove the plastic cap and loosen the locknut on the E.P.R. valve. Then, using a small screwdriver, turn the valve stem one-fourth (90°) turn counterclockwise for more cooling or clockwise for less cooling (Figure 40).

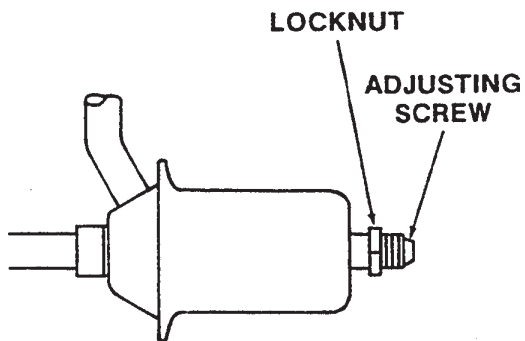

Figure 40. E.P.R. Valve Adjustment

7. Allow the system to level out for 3-5 minutes before taking another pressure reading.
8. Should the readings not fall between 69-71 P.S.I.G., repeat steps 6 and 7 until the correct reading is obtained.
9. Once the 69-71 P.S.I.G. reading is obtained, tighten the locknut snugly, remove the pressure gauge, and replace the E.P.R. Schrader access fitting cap.
10. Replace all panels.

NOTE

The compressor ON and OFF times can also affect the temperature of the hopper. Procedures for adjusting compressor ON and OFF times will be discussed in Section 5.

4.11 E.P.R. REMOVAL

CAUTION

A HEATSINK (WET CLOTH) MUST BE USED TO PREVENT DAMAGE TO THE VALVE.

1. Assuming the necessary panels are removed for adjusting the E.P.R. valve, perform the following procedures for removing the E.P.R. valve.

WARNING

DISCONNECT FREEZER FROM ELECTRICAL SUPPLY SOURCE BEFORE SERVICING.

2. Recover the refrigerant charge, then leave a port open to prevent pressure buildup when applying heat.

WARNING

BOTH SUCTION SIDE SOLENOIDS MUST BE ACTIVATED FOR PROPER PURGING OF SYSTEM. USE POWER CORD PART NO. 430119 OR EQUIVALENT FOR DIRECT CONNECTION.

3. Remove the foam insulation from the surrounding lines.
4. Apply a heatsink (wet cloth) to the E.P.R. valve.
5. Unsweat the two refrigeration lines.
6. Remove the E.P.R. valve with the heatsink.

4.12 E.P.R. VALVE INSTALLATION

To replace the E.P.R. valve, perform the following procedures:

CAUTION

WHEN REPLACING THE E.P.R. VALVE, A HEATSINK (WET CLOTH) MUST BE USED TO PREVENT DAMAGE TO THE VALVE.

1. Position the E.P.R. valve, with heatsink, so hopper evaporator outlet line and the line leading to the low side of the system correspond with the proper valve ports (Figure 41).

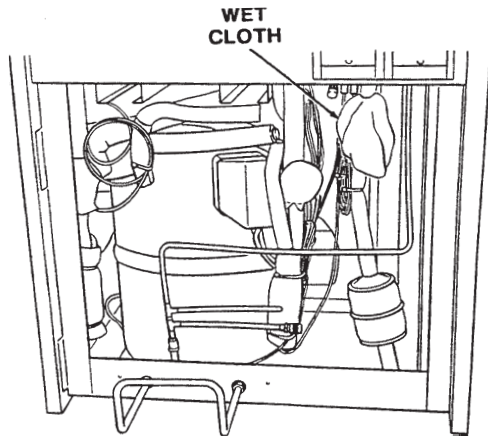

Figure 41. E.P.R. Valve and Lines

2. Braze the lines to the E.P.R. valve using the appropriate brazing material.
3. Remove the heatsink from the E.P.R. valve.
4. Replace any foam insulation to the surrounding lines.
5. Replace the filter drier using the appropriate brazing material (Figure 42).

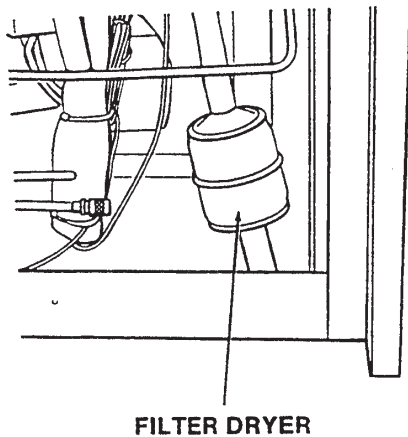

Figure 42. Filter Drier

6. Once the E.P.R. valve and filter drier are installed, the refrigeration system must be leaked checked, purged and evacuated to 500 microns of mercury or less at either barrel outlet access fitting preceding the suction line solenoid valves.

4.13 CAPILLARY TUBES

Capillary tube replacement may be necessary if the correct hopper cooling cannot be obtained. A plugged or restricted capillary tube or drier will result in a warm capillary tube at the end going to the hopper when the freezer is running. Also, the pressure reading at the E.P.R. valve will equal suction pressure at the compressor if the tube is totally blocked.

4.14 CAPILLARY TUBE REMOVAL



WARNING

DISCONNECT FREEZER FROM ELECTRICAL SUPPLY SOURCE BEFORE SERVICING.

1. Remove the Phillips head screws from the left side and front panels and pull the panels down and out.
2. Recover the refrigerant charge, then leave a port open to prevent pressure buildup when applying heat.



WARNING

BOTH SUCTION SIDE SOLENOIDS MUST BE ACTIVATED FOR PROPER PURGING OF SYSTEM. USE POWER CORD PART NO. 430119 OR EQUIVALENT FOR DIRECT CONNECTION.

3. Unsweat capillary tube drier assembly at the drier inlet and at the hopper inlets.

NOTE

Before unsweating capillary tubes at the hopper inlets, it will be necessary to remove the foam insulation from the capillary at that connection.

4. Remove the capillary tube drier assembly.

4.15 CAPILLARY TUBE INSTALLATION

1. Position the capillary tube drier assembly so the drier inlet tube is in position to be brazed. Braze using the appropriate material.

- Position the capillary tube and braze the tube to the hopper using the appropriate material. (Figure 43)

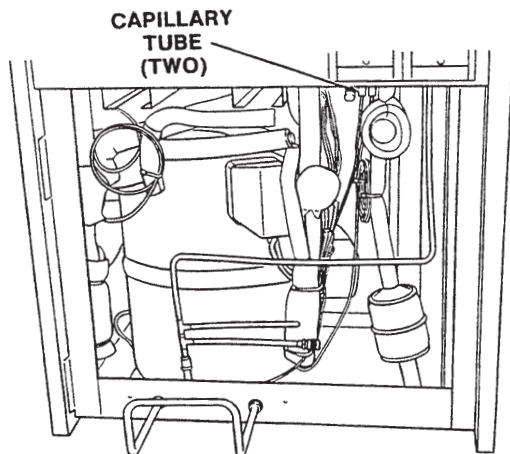

Figure 43. Capillary Tube and Drier Assembly

- Replace the foam insulation to the hopper inlet connections.
- Replace filter drier using the appropriate brazing material (Figure 44).

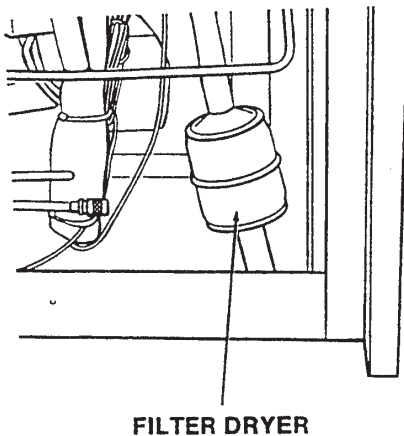

Figure 44. Filter Drier

- Once the capillary tube drier assembly and filter drier are installed, the refrigeration system must be leaked checked, purged and evacuated to 500 microns of mercury or less at either barrel outlet access fitting preceding the suction line solenoid valves.

4.16 SOLENOID VALVE

Some models have suction line and liquid line solenoid valves. To check for leaking valve seats, follow the procedure outlined below.

NOTE

Freezer barrels must not contain frozen product for this test.

- To check the suction line solenoid valve seats, we must keep the liquid line solenoid open. Use power cord, Part No. 430119, or equivalent, for direct connection (Figure 45). Then attach a low side pressure gauge to the access fitting after the expansion valve. Force the opposite side to run. If the pressure drops more than 3 PSI in 30 seconds on the side not calling for refrigeration, the suction line solenoid valve seat leaks and should be replaced. Repeat the procedure for the other side.

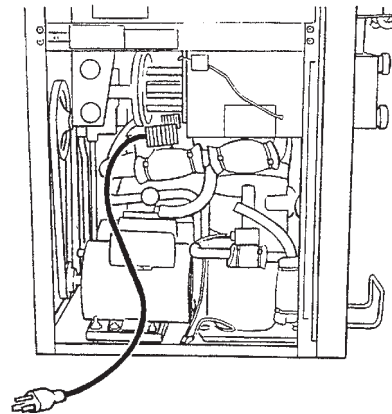

Figure 45. Power Cord

- To check the liquid line solenoid valve seats, we must disconnect one of the electrical lines from each of the liquid line solenoids. Protect the terminal end of the disconnected electrical line with a piece of electrical tape. Then, connect the low side pressure gauges to the access fittings after the expansion valves. Force the left and right sides to run by turning the OFF/ON switch to the ON position and opening the spigots. The gauges should show approximately 9" of vacuum after 1 minute. If the gauge does not reach 1" of vacuum in 1 minute and hold, you may have a leaking solenoid valve seat or leaking valves in the compressor. You can determine which solenoid valve is leaking by watching the pressure rise in each of the barrels. The barrel with the greatest pressure rise should have the leaking solenoid valve seat (Figure 46).

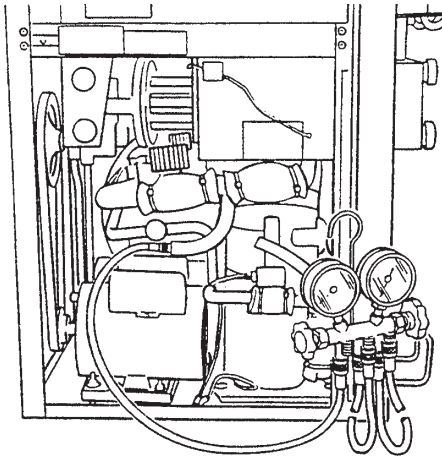

Figure 46. Pressure Gauges

4.17 SOLENOID MAGNETIC COIL REMOVAL

1. Remove the Phillips head screw from the bottom of the left side panel and remove the side panel by sliding down and out. Locate the faulty valve, then remove the Phillips head screws from the back or front panel, if necessary, by sliding down and out.
2. Identify (mark) and disconnect the electrical wires (Figure 47).

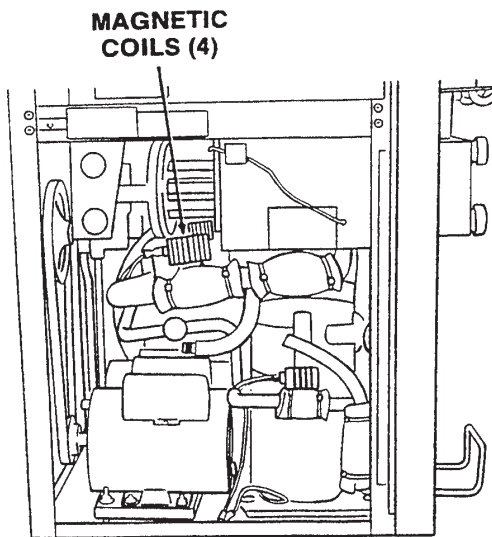

Figure 47. Solenoid Replacement

3. Remove the retainer from the top of the solenoid and pull the magnetic coil off.

NOTE

The retainer may be a screw, nut, or clip.

4.18 SOLENOID MAGNETIC COIL INSTALLATION

To replace the magnetic coil, perform the following procedures:

1. Push the magnetic coil on the solenoid body and replace the retainer.
2. Connect the two electrical wires.

4.19 LIQUID AND SUCTION LINE SOLENOID VALVE REMOVAL



DISCONNECT FREEZER FROM ELECTRICAL SUPPLY SOURCE BEFORE SERVICING.

1. Remove the screw from the bottom of the left side panel and pull the panel down and out.
2. Locate the faulty valve, then remove the front or back panel if necessary.
3. Recover the refrigerant charge, then leave a port open to prevent pressure buildup when applying heat.
4. Identify and disconnect the two wires from the solenoid coil.
5. Remove the retainer holding the coil to the solenoid body and remove the coil (Figure 48).

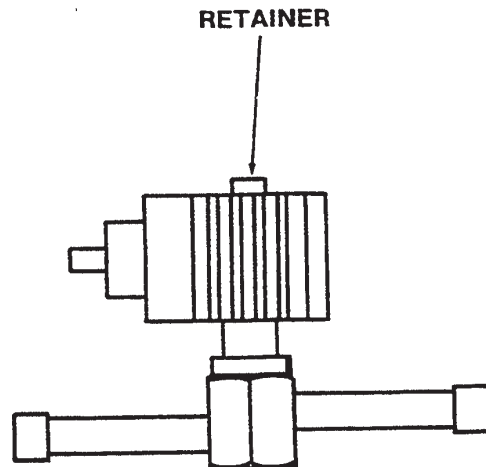

Figure 48. Solenoid Coil Removal

6. Apply a heatsink (wet cloth) to the valve body and unsweat the two joints. Remove the valve body.

4.20 LIQUID AND SUCTION LINE SOLENOID VALVE INSTALLATION

1. Position the new valve with the arrow pointing toward the direction of flow or expansion valve.
2. Apply a heatsink (wet cloth) to the valve body.
3. Braze the two joints using the appropriate brazing material.
4. Replace the filter drier using the appropriate brazing material.
5. Once the valve and filter drier are installed, the refrigeration system must be leaked checked, purged and evacuated to 500 microns of mercury or less at either barrel outlet access fitting preceding the suction line solenoid valves.
6. Replace all panels.

4.21 WATER VALVE

The water valve meters the proper amount of water to cool the refrigerant to a temperature that will result in the proper head pressure.

Before making any adjustments, check for adequate water supply.

4.22 WATER VALVE ADJUSTMENT

To determine whether or not the water valve is in need of adjustment, perform the following procedures:



WARNING

DISCONNECT FREEZER FROM ELECTRICAL SUPPLY SOURCE BEFORE SERVICING.

1. Remove the Phillips head screws from the back panel and slide the panel down and out.
2. Remove the Phillips head screws from the front panel and slide the panel down and out.

3. Remove the cap from the high side Schrader access fitting and install a 0-500 P.S.I.G. gauge.
4. Connect the freezer to the electrical supply, start the refrigeration cycle, and read the pressure.
5. The proper gauge reading should be approximately 225-235 P.S.I.G.(E131G) P.S.I.G. AND 235-245 (F131G) (Figure 49).

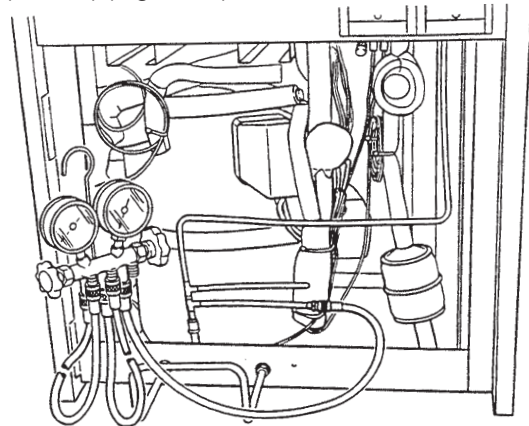
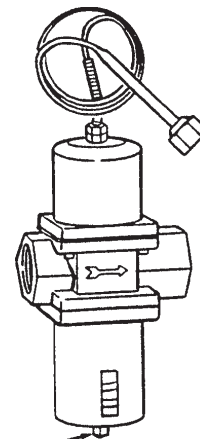

Figure 49. Gauge Connection

To adjust the water valve, turn the adjustment screw counterclockwise to increase head pressure and clockwise to decrease head pressure (Figure 50).



ADJUST

Figure 50. Water Valve Adjustment

4.23 WATER VALVE REMOVAL



WARNING

DISCONNECT FREEZER FROM ELECTRICAL SUPPLY SOURCE BEFORE SERVICING.

Assuming the back, side, and front panels are removed, perform the following procedures for removing the water valve.

1. Turn off and disconnect the water supply and drain. Blow out the water lines with compressed air or CO₂.
2. Recover the refrigerant charge, then leave a port to open to prevent pressure buildup when applying heat.
3. Disconnect the capillary tube from the high side line.
4. Remove the water line from the valve.
5. Remove the two screws holding the water valve to the frame and remove the valve.

4.24 WATER VALVE INSTALLATION

To replace the water valve, perform the following procedures:

1. Position the water valve and attach to the frame using the two screws.
2. Connect the water line to the valve.
3. Connect the capillary tube.
4. Evacuate the system and recharge to the nameplate specifications.
5. Connect the water supply line and turn on the water.
6. Check for leaks.
7. Start the freezer and adjust the water valve.

8. Replace all panels.

4.25 REFRIGERANT CHARGE (ALL MODELS)

The following symptoms will occur if there is a slow leak in the system:

- A. At first, the freezer will have a tendency to run longer than usual.
- B. As more refrigerant leaks out, the freezer will run continuously and eventually the product will not freeze down.
- C. The hopper will not cool the product properly.

If a refrigerant leak is detected in the system, refer to the following steps:

- A. Determine the exact location of the leak.
- B. Reclaim the entire charge.
- C. Repair the leak.
- D. Replace the drier.
- E. Evacuate the system.
- F. Charge by adding R404A to the system by weight. Refer to the label on the freezer for total charge requirements.
- G. Check for leaks.

SECTION 5 CONTROLS

5.1 CONTROL SYSTEM TYPE 4

The control system is the brain of the freezer. To understand how to service the freezer, it is essential to understand how the control system operates. The Type 4 control is a consistency control and a temperature control. To change functions, it is necessary to cut one diode.

The control system when placed in the consistency mode monitors the consistency (firmness) of the product (mix) in the freezer evaporator. As the product freezes, the drive motor develops a higher torque (resistance) because of the freezing of the product in the evaporator. The energy used to operate the drive motor is in direct proportion to the torque. As the drive motor torque increase, so does the energy required to operate the motor. The program module senses the energy usage and shuts off the drive motor when the preprogrammed energy value is reached. The freezer will remain OFF until the temperature rises to the preset looking temperature (barrel temperature), then start.

The control system, when placed in the temperature mode, monitors the product temperature in the freezer evaporator. When the product temperature increases, the temperature sensor probe sends an electronic signal to the temperature control, which signals the compressor and drive motor to switch ON. When the temperature control is satisfied, the compressor will stop, and approximately 10 seconds later, the gearmotor will stop. The control also contains a hopper temperature control (separate hopper refrigeration system only) and liquid level indicator to monitor the mix temperature and level in the hopper. When servicing a freezer in the consistency mode, keep in mind the control system monitors product consistency. To minimize the beating of product in the evaporator, the program module will switch to the idle mode after the preset number of consistency cycles are complete. In the idle mode, the control is programmed to maintain a preset hopper and barrel temperature. In this idle mode, a servable consistency will not be held.

5.2 POWER BOARD

The power board is where the actual sensing of the drive motor energy usage occurs. The power board also supplies energy to the program module and sends electronic signals associated with the drive motor sensing. The 115 or 230/12 volt transformer and associated circuitry are used to supply D.C. voltages to operate the program module. There are two relays to transfer power to the compressor and drive motor

contactors. The power board has a third relay; it is used to transfer power to control the liquid line solenoid valve. The relay will close after 2 hours of red light idle causing the solenoid to open. There are four L.E.D.'s to monitor the board's operation. One L.E.D. indicates power to the board. Two, three, and four indicate when the relays are active.

5.3 PROGRAM MODULE

The program module is a multifunction control. It can control product consistency or product temperature in the barrel, mix temperature in the hopper, and indicate mix level in the hopper. The board can be programmed to control the functions of various freezers producing many different products. To properly program the board, it is necessary to understand the purpose of each indicator light, switch, potentiometer, jumper, and the liquid crystal display.

A. Indicator Lights

1. The Power On indicator light, when illuminated indicates the program module is receiving D.C. power from the power board.
2. The HPR light, when illuminated, indicates power is available at J7 to control a separate refrigeration system.

B. Liquid Crystal Display

1. In the calibration mode, abbreviated word indicators will be displayed indicating the control function and set points being calibrated.
 - a. TM-On Time
 - b. STB-Stand-By Product Temperature
 - c. CRS-Auger Drive Motor Current (amps)
 - d. MTR-Motor Slope Adjustment
 - e. SRV-Product Temperature
 - f. HPR-Hopper Temperature
 - g. LKG-Temp. set point in RDY mode.
2. In the operating mode, an abbreviated work indicator will be displayed indicating the operating function.
 - a. DRV-Drive Motor
 - b. CMP-Compressor
 - c. LKG-Consistency
 - d. CLN-Clean

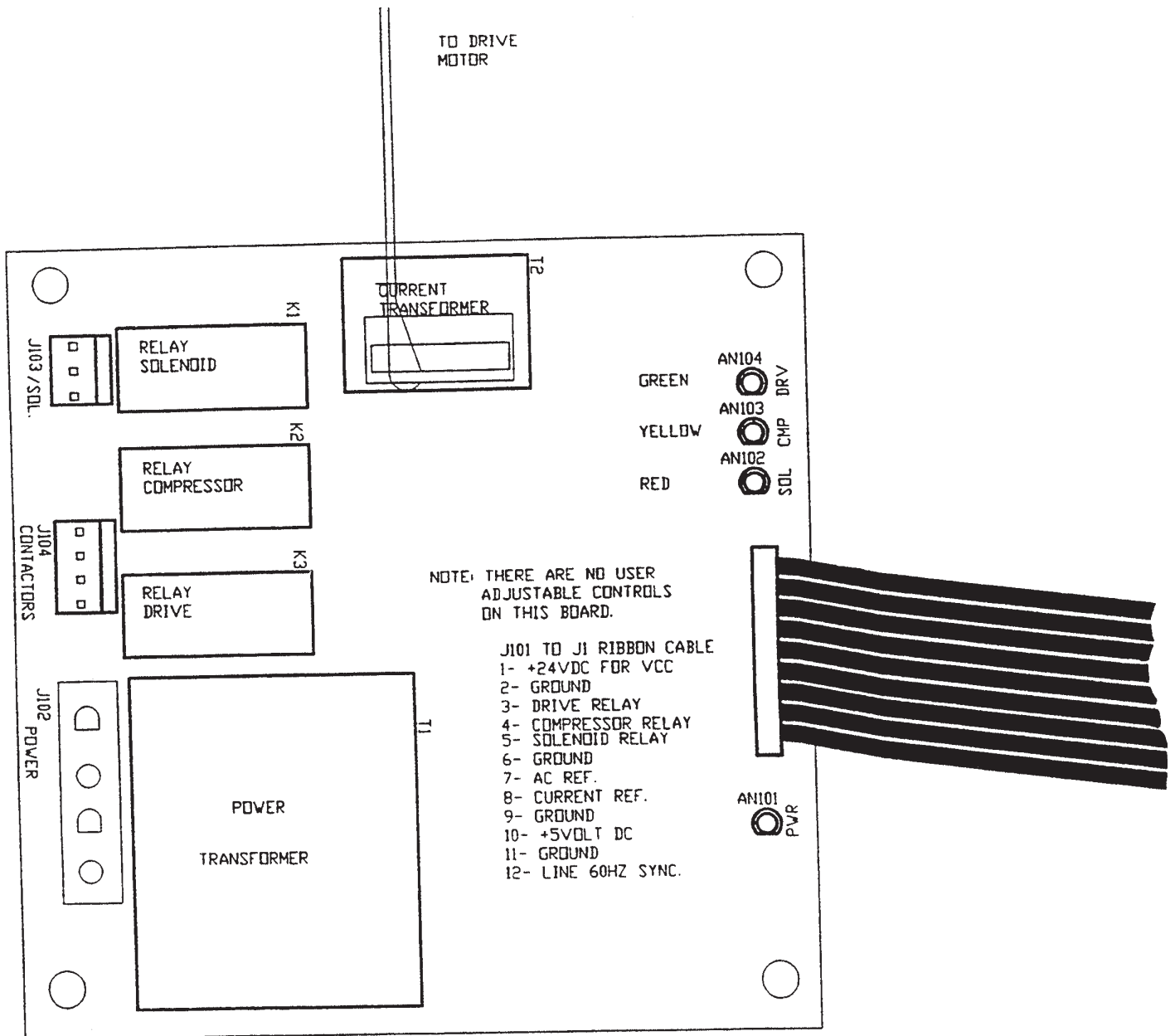

J103
 1-N.O.
 2-N.C.
 3-COMMON

J104
 1-COMPRESSOR
 2-DRIVE
 3-COMMON
 4-NO CONNECTION

J102
 1-2-LINE 1
 3-4-LINE 2
 POWER IN

Figure 51. Power Board

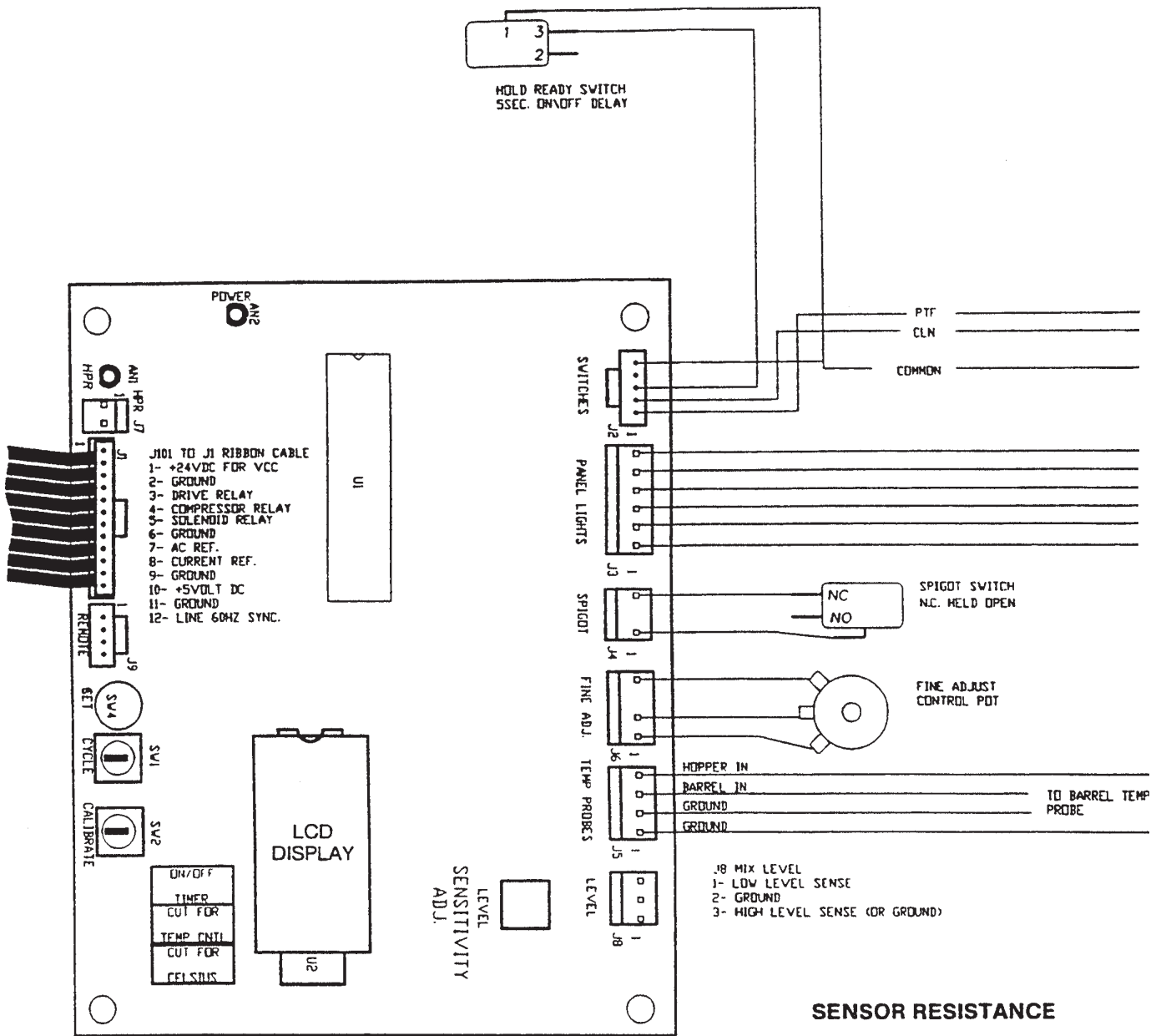

NOTE
Remove connector from board before checking. Insert V.O.M. probes from wire side of connector.

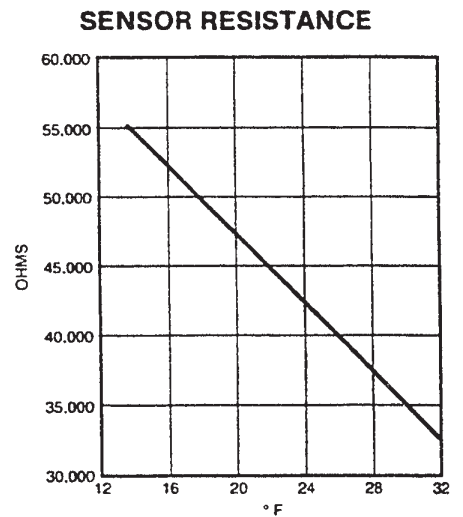

NOTE: SENSOR IS 10,000 OHMS AT 77°

Figure 52. Program Module

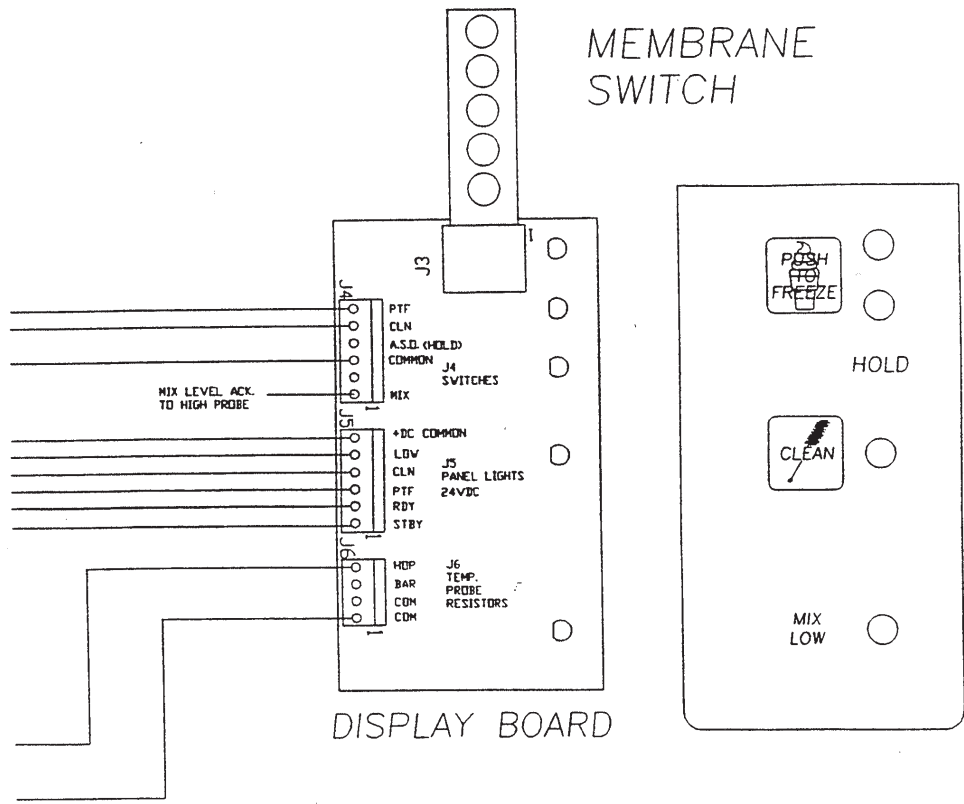

Figure 53. Membrane Switch Panel Display Board

3. When the cycle switch SW1 is placed in the) position, the control will go through a self-test sequence and the results will be displayed
 - a. OK-Passed all Checks
 - b. ERR-Error Condition
4. Error condition code display. The error condition code directs you to the location of the malfunction.
 - a. 01 Program Board
 - b. 02 Power Board
 - c. 03 Low Torque Error
 - d. 04 Clean Error
 - e. 05 Barrel Sensor
 - f. 06 Hopper Sensor
 - g. 07 Drive Motor

start at the end of the set off time. The freezer will remain on until brought to consistency. After the selected number of operating cycles, the control will operate in idle mode strictly by On/Off timing. If the diode is not removed from the circuit, the On/Off timers function only during the transition from normal operating set point to idle (STB) temperature set point.

2. Celsius Display Select. Selection for display is Fahrenheit and when removed from the circuit is Celsius.
3. Consistency/Temperature Mode Select. A removable diode is provided to change the control from basic function of a consistency control or a temperature control.

C. Board Mounted Selectors

There are three diodes which when removed from the circuit cause changes in the control logic.

1. On/Off timers. This diode is removed from the circuit for those soft serve freezers without sensors for barrel or hopper temperature. In the operating consistency mode, the freezer will

D. Calibration Function

The Cycle Mode Switch (SW1) programs the number of cycles before the freezer enters the idle mode (1-9). The calibration function is activated by placing the Cycle Mode Switch in the "0" position. Place the On/Off switch in the On position. The On Board pushbutton switch (SW4 SET) is used to advance through the steps. The following chart indicates the steps in calibrating the control.

E. Control Calibration

NOTE

Values below are default values only. Values for your freezer can be found inside the decorative header panel or in the information packet behind the left side panel

PUSH BUTTON ACTION	DIGIT	DISPLAY FUNCTION	WORD	NOTES
<p>NOTE Push-button actuation enters "read out" and steps ahead to the next adjustment.</p>		OK		Self-Test
<p>First push-button actuation Force Freeze Seconds of compressor ON time after the spigot is closed.</p>		10 ^{SEC}	TM	Rotate "calibrate" to adjust force freeze ON time 3-30 seconds. NOTE Calibrate is SW2
<p>Second push-button actuation STB (Idle) ON time. ON time of freezer during RDY to Standby (idle/standby mode only).</p>		10	TM & STB	Rotate calibrate to adjust STB (Idle) ON time 10-90 seconds. Range = 18-199 sec.
<p>Third push button actuation Idle Off Time. 1/10th of the OFF time RDY to Standby (idle/standby mode only).</p>		20 ^{SEC}	TM & STB & SEC	Rotate calibrate to adjust STB (Idle) OFF time 18-199 seconds. NOTE This is one-tenth actual OFF time.
<p>Fourth push-button actuation AMPS. Preliminary coarse amp setting for consistency range.</p>		3.6	AMP CRS	Rotate calibrate to set 2.0 to 17.0 drive motor amps at consistency. Fine pot must be at mid-range. Display is total amps setting (fine plus coarse).
<p>Fifth push-button actuation Serve Temp. (Temperature control mode only.)</p>		10 ^{°F}	SRV	Rotate calibrate to adjust serve temperature 5-35°F (=15±2°C) NOTE Display includes fine temp.setting. NOTE Fine pot must be at midrange during the adjustment.
<p>Sixth push-button actuation STB (Idle) Temp. Standby barrel temperature.</p>		24 ^{°F}	STB	Rotate calibrate to adjust STB (Idle) temperature 24-59°F (-4.5 to 15°C)
<p>Seventh push-button actuation STB (Idle) Temperature differential (rise).</p>	LKG	1 ^{°F}	STB	Rotate calibrate to adjust control limits 1-5°F.
<p>Eighth push-button actuation Motor Slope. Motor slope: The rate of amperage change at cut-out with respect to the rate of line voltage change.</p>		.8	MTR	Rotate calibrate to adjust motor slope .5 - 3.5.

PUSH BUTTON ACTION	DIGIT DISPLAY FUNCTION WORD	NOTES
<p>Ninth push-button actuation Hopper Temp. Used for separate hopper refrigeration system only.</p> <p>Tenth push-button actuation Barrel Temp. Rise in barrel temperature above the serve temperature. (not product temperature)</p> <p>Eleventh push-button actuation. Enters last change.</p>	<div style="text-align: center; border: 1px solid black; padding: 5px; margin-bottom: 10px;"> 25 °F HPR </div> <div style="text-align: center; border: 1px solid black; padding: 5px;"> 19 °F LKG </div>	<p>Rotate calibrate to adjust hopper temperature set point 25 - 45°F (-4±7°C).</p> <p>Rotate calibrate to adjust temperature rise set point 1 - 45°F (-17±17°C)</p> <p>Enter---- returns to Step #1 for review.</p>

NOTE

If the word "Error" appears, refer to Error Condition for more information.

- * Not used if set up for temperature (shake) control.
- ** Not used if set for consistency (S.S.) control.
- *** Separate Hopper Refrigeration System only.
- **** If set for temperature control this is a rise in barrel temperature above the serve temperature.
- ï Forced Freeze On Time: Minimum run time activated by opening and closing the spigot, or pushing the Push To Freeze switch.
- ii Motor Slope: The rate of amperage change at cutout with respect to the rate of line voltage change.

F. Error Conditions

When the rotary switch SW1 is rotated to the Self-Test position (calibrate "0"), the control will be in the test mode. All outputs are off. The control will go through a self-test sequence and then "OK" will come on indicating the control functions tested are correct. These indicators will remain on until the rotary switch is turned. Failure of any function will cause "OK" to remain off and "ERR" to be displayed. The Push-To-Freeze light will flash the same number of times as the error code numeral, then pause and repeat. Any error causing condition must be corrected, then the power turned off, and back to ON for reset. Test to include the following:

	<u>Malfunction</u>	<u>Indicator</u>
a. Program Board	01	ERR
b. Power Board	02	ERR
c. Low Torque Error	03	ERR
d. Clean Error	04	ERR
e. Barrel Sensor	05	ERR
f. Hopper Sensor	06	ERR
g. Drive Motor	07	ERR

NOTE

Error codes can be overridden by holding the clean switch on while power is applied, except for the clean error. Errors must be corrected to resume normal operation.

NOTE

Last error code can be read out on display log pushing SW4 while in run mode.

NOTE

If the Clean switch is operated three times within 10 seconds, this will cause the Push-To-Freeze light to flash and the clean function will be disabled for 10 minutes. The power switch must remain on or the 10 minute timer will not time out. A flashing clean light is not an error. See the Troubleshooting Section for more error information.

G. Switches/Lights

NOTE

All models do not have the Hold Ready Switch/Light or the Mix Low Switch/Light.

1. Spigot Switch. The Spigot Switch is a normally closed held open switch. When the spigot is opened, the switch will close starting the freezer.
2. Push-To-Freeze Switch and Light. The Push-To-Freeze switch is a normally opened snap switch. When the switch is depressed, the switch will close starting the freezer. The red Push-To-Freeze light will be illuminated whenever the product is not at consistency. The red light, when flashing, indicates an error condition. The green Push-To-Freeze light will illuminate when the product is ready to serve and flashes just prior to reaching consistency.
3. Hold Ready Switch and Light. The Hold Ready Switch is a normally open momentary switch. When the switch is depressed, and held for 5 seconds the switch will close placing the freezer in a continuous ready condition, and the Hold Ready light will illuminate. To allow the automatic idle mode, push the Hold Ready Switch again, and hold for 5 seconds. Then after the preset number of consistency cycles, the freezer will go into the idle mode.
4. Clean Switch and Light. The Clean Switch is a normally open snap switch. When the Clean Switch is depressed, only the auger will run and the red Clean light will illuminate. To stop the auger, push the Clean Switch again.
5. Mix Low Light. The Mix Low Light will illuminate when the mix level is below the probe. To cancel the light, fill the hopper to above the probe.
6. Fine Control Adjuster. When the control is in the consistency mode, the adjusted has a range of 1.5 amps from the coarse control setting. When the control is in the temperature mode, the adjuster has a range of 4°F from the coarse control setting.

NOTE

If the Clean Switch is operated three times within 10 seconds, the Push-To-Freeze Light on the panel will flash and this function will be disabled for 10 minutes.

H. Freezer Operation

1. Consistency Mode. When the Off/On Switch is placed in the On position, the red Push-To-Freeze light will illuminate and the freezer will run in the idle mode. When the Push-To-Freeze Switch is depressed, the freezer will run until it reaches consistency, then after the preset On Time, the green Ready Light will illuminate and the freezer will stop. When the spigot is opened, the drive will start immediately and the compressor 3-4 seconds later. When the spigot is closed, the freezer will run until it reaches consistency, then after the preset On Time, stop.

The barrel temperature is monitored. Whenever the temperature increases above the LKG temperature, the freezer will start and the product brought back to consistency. If no product is dispensed and the Push-To-Freeze switch is not depressed, the freezer will enter the idle mode after the preset number of consistency cycles. When in the idle mode, the freezer will cycle on the preset On and Off timers until the stand-by LKG temperature is reached. Whenever a product is dispensed or the Push-To-Freeze switch is depressed, the control will return to the freeze down cycle.

NOTE

The drive will run for 10 seconds every 5 minutes to circulate product. A normal on cycle will reset the Five-Minute Timer.

If the Hold Ready Switch is depressed and held for 5 seconds, the green light will illuminate and the freezer will not be allowed to enter the idle mode. It will then remain in the consistency mode. If the switch is depressed again and held for 5 seconds, the green Hold light will go off and the freezer will be allowed to enter the idle mode after the programmed number of consistency cycles.

2. Temperature Mode. To start the freezer, place the Off/On switch in the ON position. Push the P.T.F. switch to start the freezer. When the drive starts, release the Push-To-Freeze switch. The freezer will run until the preset barrel temperature is reached, then after the preset On time stop and the green ready light will illuminate. When the barrel temperature rises to the LKG temperature, the freezer will start

and run until the preset barrel temperature is reached, then after the preset On time, stop. When the spigot is opened, the drive will start immediately and the compressor 3-4 seconds later. When the spigot is closed, the freezer will run until it reaches temperature, then after the preset On time, stop.

5.4 PLUG-IN RELAYS

The relays are mounted in the electrical box located at the back of the freezer. Remove the back panel to access.

The 8-pin plug-in relays, when activated, will send power to the refrigeration solenoids and the compressor contactor. The left relay is for the left solenoid valve and the right relay is for the right solenoid valve. The function of the relay is to isolate control of the on compressor contactor (Figure 54).

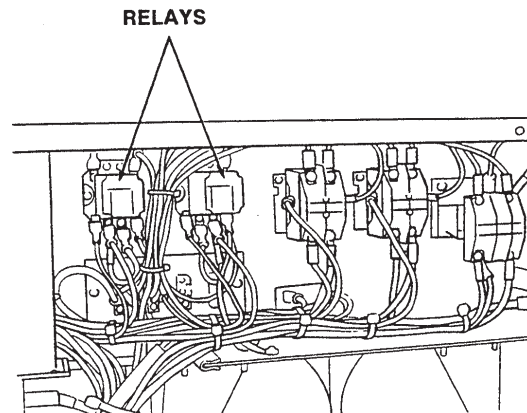

Figure 54. Plug-in Relays

5.5 CONTACTORS

The contactors are mounted in the electrical box located at the back of the freezer. Remove the back panel to access. There are three contactors, two to start the drive motor and one to start the compressor and condenser fan.

The control modules send electronic signal to trigger the contactors. The electronic signal tells the relays when to operate the contactor for the compressor and condenser fan. A separate signal is used to control the drive motor contactor. The signal to the contactors are staggered so the drive motor will always start and stop 2-3 seconds before the compressor and condenser fan. By staggering the stopping and starting of the drive motor, maximum starting torque is available and voltage spikes are reduced. The contactors are electronically isolated from the program module. This feature is very important in case of an electrical short or component failure.

5.6 SPIGOT SWITCHES

The spigot switch will automatically actuate the auger drive and refrigeration system when the spigot is opened to dispense product. When the spigot is closed, the drive motor and compressor will remain on until the product in the barrel reaches the proper consistency.

5.7 SPIGOT SWITCH REMOVAL

To remove a spigot switch, perform the following procedures:



WARNING

DISCONNECT FREEZER FROM ELECTRICAL SUPPLY SOURCE BEFORE SERVICING.

1. Remove the two Phillips head screws from the bottom of the decorative panel and slide the panel down and out.
2. Remove the dispense rate adjuster knob located below the header panel. Then remove the two Phillips head screws that retain the handle assembly. Then remove from the electrical box to access the switch (Figure 55).

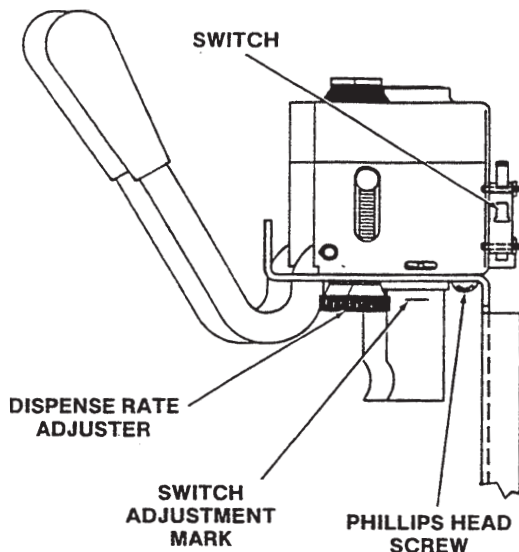

Figure 55. Spigot Switch Replacement

3. Disconnect the electrical wires and remove the switch by removing the two retaining screws, nuts, and washers.

5.8 SPIGOT SWITCH INSTALLATION

1. Install the replacement switch onto the handle assembly. Do not fully tighten the retaining screws at this time.
2. Using a pencil, mark the white plastic actuator ¼" below the stainless steel housing. Adjust the switch to activate when the spigot handle moves the plastic piece to the mark. Then, fully tighten the retaining screws (Figure 55).
3. Attach the electrical wires to the common (COM) and normally open (N.O.) terminals on the spigot switch.
4. Position the spigot handle assembly in the electrical box and fasten securely with the two Phillips head screws.
5. Replace the dispense rate adjuster knob and tighten.
6. Replace the decorative header panel and secure with the two Phillips head screws.

5.9 FRONT DOOR INTERLOCK SWITCH

When the door is securely fastened, the freezer will operate normally. When the door is removed, the drive and compressor will not run.

5.10 FRONT DOOR INTERLOCK SWITCH REMOVAL

1. Remove the front door assembly.
2. Remove the two Phillips head screws from the bottom of the decorative header panel and slide the panel down and out.
3. Remove the dispense rate adjuster knob from the right and center spigot handle assemblies.
4. Remove the two Phillips head screws from the spigot handle assemblies located below the header panel, then remove the handle assemblies.

- Remove the two electrical wires from the interlock switch (Figure 56).

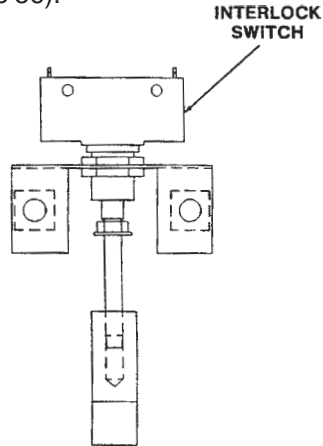

Figure 56. Interlock Switch Removal

- Remove the two Phillips pan head screws that hold the switch bracket located below the header panel.
- Measure and note the position of the switch relative to the bracket. Remove the switch from the bracket.

5.11 FRONT DOOR INTERLOCK SWITCH ASSEMBLY

- Assemble the replacement switch to the bracket and secure in the same position as the old one.
- Position the switch and bracket assembly in the electrical box and secure with the two Phillips pan head screws.
- Use a V.O.M. (Volt Ohmmeter) to check the operation of the switch when the front door is installed (Figure 57).

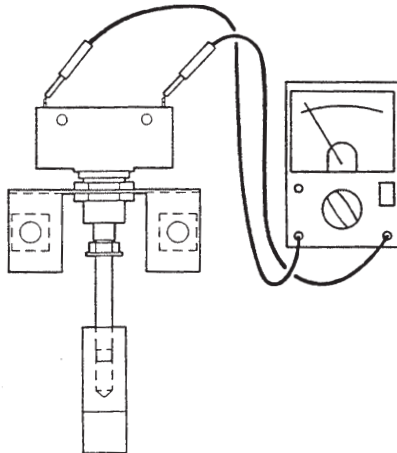

Figure 57. Interlock Switch Assembly

- Attach the two electrical wires to the common and normally open terminals.
- Position the spigot handle assemblies in the electrical box and secure with the Phillips head screws.
- Replace the spigot adjuster knob and tighten.
- Install the decorative headed panel and secure with the two Phillips head screws.

5.12 TOUCH PAD SWITCH MODULE

The touch pad switch module contains a series of “snap” switches to control freezer functions.

5.13 TOUCH PAD SWITCH MODULE REMOVAL

- Use a 5/64” Allen wrench to remove the retaining screw located at the bottom of the module.
- Remove the module from the housing by gently prying the bottom out with a small packet screwdriver.
- To open the connector labeled J3 insert a small pocket screwdriver and carefully twist counterclockwise, then pull out the ribbon (Figure 58).

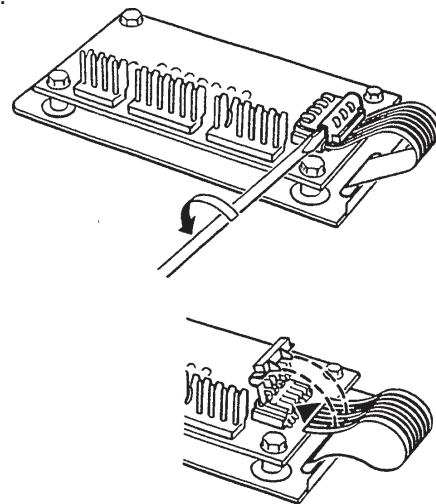

Figure 58. Switch Module Removal

- Remove the four screws holding the circuit board to the module and separate.

5.14 TOUCH PAD SWITCH MODULE ASSEMBLY

1. Position the circuit board on the new module and secure with the four screws.
2. Insert the ribbon into the connector and close the hinged portion of the connector.



CAUTION

THE CUTOUTS IN THE RIBBON MUST LINE UP WITH THE PRONGS ON THE HINGED PORTION OF THE CONNECTOR BEFORE CLOSING.

3. Place the switch module into the housing top first, then the bottom.
4. Replace the retaining screw using a 5/64" Allen wrench.

5.15 SENSOR

The sensor monitors refrigerant gas temperature exiting the evaporator. Refer to page 28 for values.

5.16 SENSOR REMOVAL

1. Loosen the two (2) Phillips head screws and remove the decorative header panel.

NOTE

To access the sensor, remove the side panel on the failed side.

2. Remove the Phillips head screw from the side panel and pull down and out. If the failure is on the right side, the back panel and side electrical box must be removed. To remove the back panel, remove the two (2) Phillips head screws, then pull down and out. To remove the electrical box, remove the two (2) Phillips head screws from the cover and remove the cover. Remove the two (2) fan wires from the terminal block. Disconnect the two (2) red molex connectors from the back of the electrical box (Figure 59). Remove the four (4) Phillips head screws that hold the electrical box to the frame and remove through the rear of the freezer.

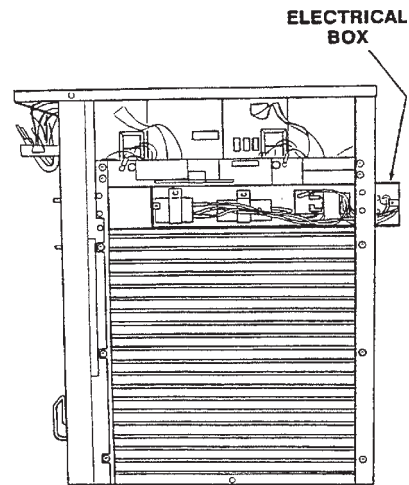

Figure 59. Electrical Box Removal

3. Remove the two (2) screws from the cover plate and pry off (Figure 60).

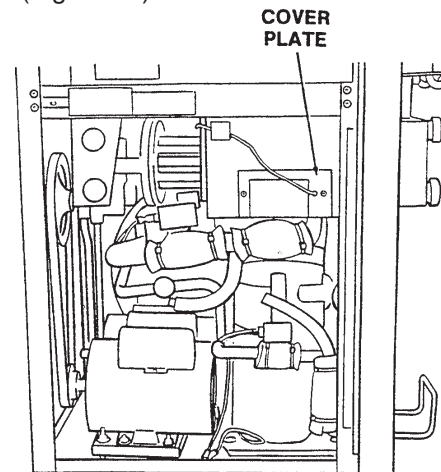

Figure 60. Cover Plate Removal

4. Use a one (1) inch putty knife to cut the foam installation by gently pushing straight in (Figure 61).

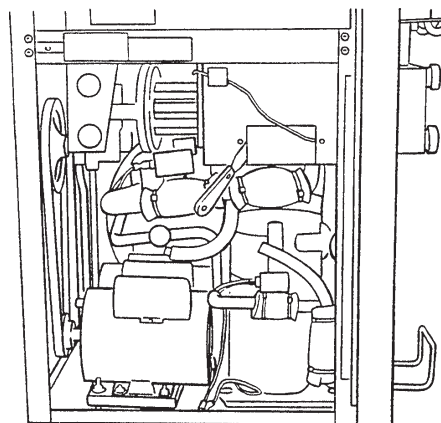

Figure 61. Foam Insulation Removal

- Carefully remove the foam and thermal mastic until the sensor is visible, then cut the small ty-raps that hold the sensor, and remove (Figure 62).

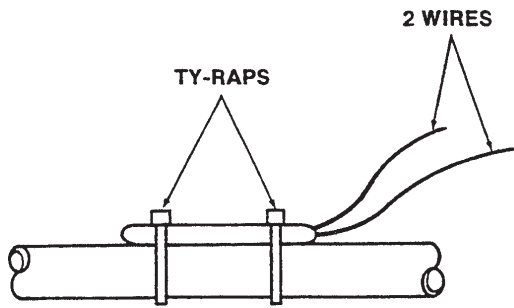

Figure 62. Ty-raps Removal

- Disconnect the two wires in the electrical box at the connectors.

5.17 SENSOR INSTALLATION

- Thoroughly clean the area where the sensor is to be replaced.
- Apply a small amount of thermal mastic to the area where the sensor will be mounted.
- Carefully install the sensor and fasten securely with two (2) small ty-raps. Then completely cover with thermal mastic.

NOTE

The sensor must be installed without air gaps and must not contact the evaporator raps. If there are any air gaps or if the sensor contacts the rap, the freezer will not function properly.

- Replace the foam installation using an aerosol can of foam, available at most hardware stores.
- After the foam has cured, remove the excess and replace the cover plate.
- Connect the two electrical wires.
- If the repair was to the right side, replace the electrical box from the back of the freezer and secure with the four (4) Phillips head screws. Connect the two (2) red molex connectors. Connect the two (2) fan wires to the terminal block. Install the cover and secure with the two (2) Phillips head screws.

- Replace all panels.

5.18 PREPARATION FOR MAJOR COMPONENT REMOVAL

The procedure set forth in this section must be followed completely and in the order in which they appear.

To remove any or all of the major components of the freezer, the following steps must be performed first.



WARNING

DISCONNECT FREEZER FROM ELECTRICAL SUPPLY SOURCE BEFORE SERVICING.

- Remove the Phillips head screw from the bottom of each side panel and remove the side panels by pulling down and out.
- Remove the two Phillips head screws from the back panel and remove the back panel by pulling down and out.
- Remove the two Phillips head screws from the lower front panel and remove the panel by pulling down and out.

5.19 CONDENSER FAN MOTOR AND LUBRICATION

The condenser fan motor is specifically designed for application in this freezer. The motor requires lubrication every six months with an SAE #20 oil. Three to six drops are required. **DO NOT OVER LUBRICATE.**

5.20 CONDENSER FAN MOTOR REMOVAL

- Remove the cover from the lower electrical box located just above the condenser on the right side of the freezer.
- Locate the terminal block and identify the two terminals the fan motor wires are connected to. Then, remove the two wires (Figure 63).

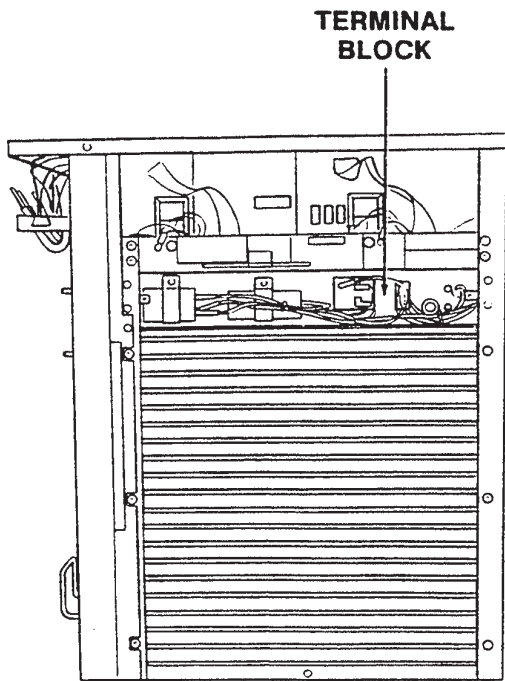

Figure 63. Fan Motor Connections

3. Cut only the ty-raps necessary to remove the fan motor wires from the main bundle of electrical wires.
4. Loosen the socket head screw holding the fan blade to the motor shaft.
5. Remove the four hex head nuts and washers securing the fan motor bracket to the shroud (Figure 64).

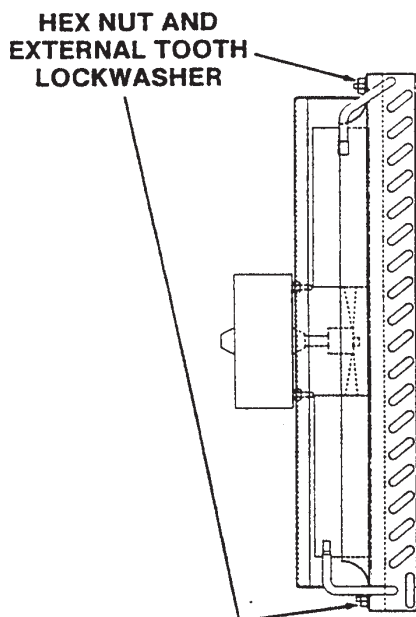

Figure 64. Fan Bracket Removal

6. Slide the fan blade off the motor shaft and remove the fan motor and bracket from the freezer.
7. Remove the fan motor from the bracket.

5.21 CONDENSER FAN MOTOR INSTALLATION

1. Install the replacement fan motor onto the bracket and secure with the three hex nuts and washers.
2. Install the motor and bracket assembly on the shroud while sliding the fan blade onto the motor shaft. Then, secure with the four hex head nuts and washers.
3. Adjust the position of the fan blade so that adequate clearance is provided both to the mounting bracket and the condenser. Then, fully tighten the fan blade setscrew.

4. Route the electrical wires to the terminal block and attach.
5. Secure the electrical wires by replacing all ty-raps that have been previously removed. Check for clearance between wires and moving objects.
6. Replace all panels.

5.22 DRIVE MOTOR

The drive motors are designed specifically for their application. The drive motors are used to rotate the auger assembly. The start and run capacitors are located on the motors. An internal normally closed centrifugal switch starts the drive motor. The drive motor is equipped with a thermal overload protector. A tripped overload will cause an error condition. If the overload trips, allow the drive motor approximately 15 minutes to one hour to reset.

5.23 DRIVE MOTOR REMOVAL

After the electrical supply has been disconnected and the necessary panels have been removed, the drive motors can be removed by performing the following procedures:

1. Loosen the belt tension adjusting nut and remove the drive belt (Figure 65).

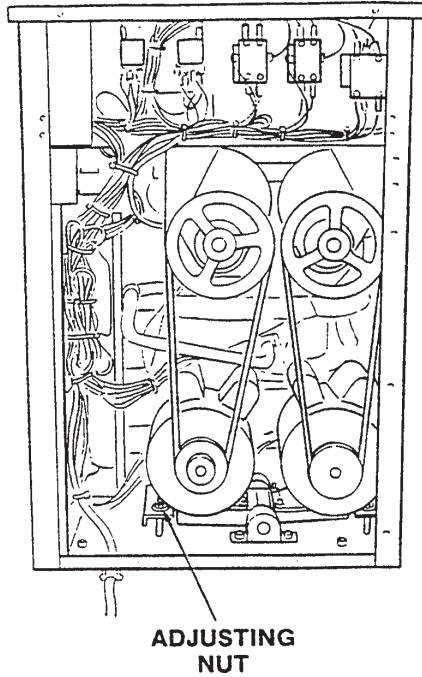

Figure 65. Drive Belt Removal

2. Remove the four bolts holding the drive motor to the mounting plate.
3. Turn the motor and remove the electrical cover plate. Identify and disconnect the four electrical wires (Figure 66).

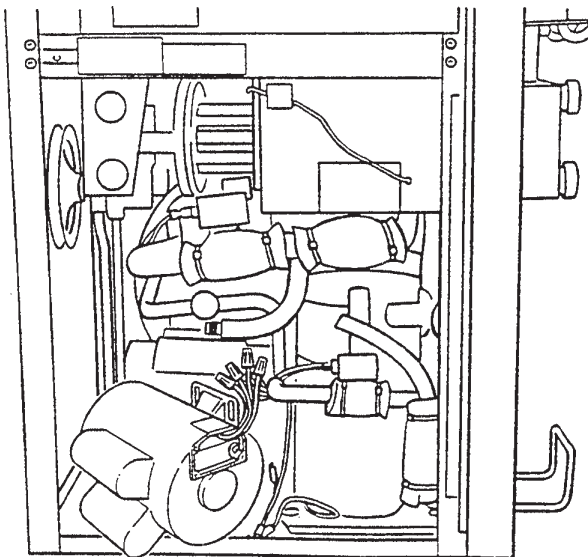

Figure 66. Drive Motor Wire Removal

4. Use an Allen wrench to loosen the pulley setscrew. Remove the pulley and key.

5.24 DRIVE MOTOR INSTALLATION

1. Fit the key and pulley to the replacement motor.
2. Remove the cover plate and connect the four electrical wires, then replace the cover plate.
3. Install the motor on the mounting plate and secure with the four bolts. Align the motor on the mounting plate and tighten the four bolts.
4. Align the motor pulley to the top pulley and tighten the setscrew (Figure 67).

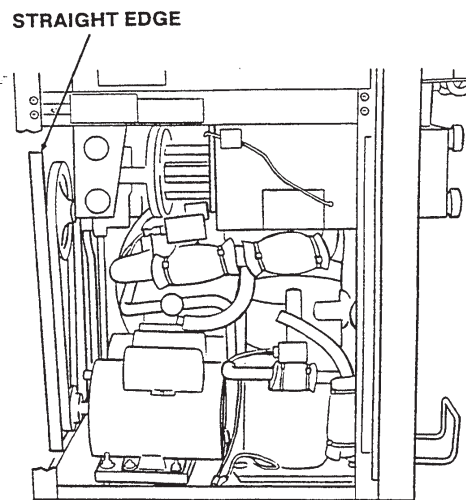

Figure 67. Motor Pulley Adjustment

NOTE

You must have proper alignment or short belt life will result.

5. Install and adjust belt to the proper tension (Figure 68).

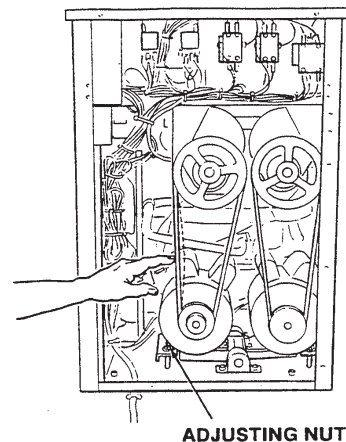

Figure 68. Belt Tension Adjustment

5.25 SPEED REDUCER

The speed reducer is a heavy duty sealed unit that does not require any maintenance.

5.26 SPEED REDUCER REMOVAL

1. Remove the front door assembly, auger support and bushing, auger shaft and flights, and rear seal assembly.
2. Loosen the belt tension adjusting nut and remove the belt.

NOTE

The spacer between the speed reducer and the barrel is used on the "E" model only.

3. Use a 9/16" box end wrench to remove the three bolts holding the speed reducer to the spacer (Figure 69).

MOUNTING BOLTS (3)

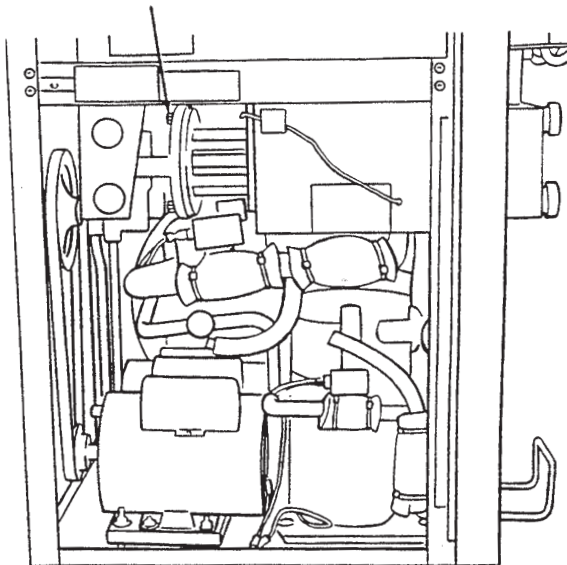

Figure 69. Speed Reducer Removal

4. Use a 3/4" wrench to remove the two bolts holding the speed reducer to the mounting bracket.
5. Remove the speed reducer from the freezer. Then, using an Allen wrench, loosen the setscrew and remove the pulley and key.

5.27 SPEED REDUCER INSTALLATION

1. Assemble the pulley and key onto the replacement speed reducer. Do not fully tighten setscrew.
2. Position the speed reducer to match the holes in the support bracket and spacer. Then secure using the appropriate bolts.
3. Align the speed reducer pulley with the motor pulley and fully tighten the setscrew (Figure 70).

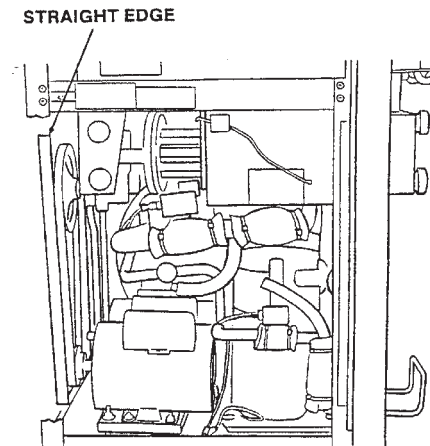

Figure 70. Speed Reducer Adjustment

NOTE

You must have proper alignment or short belt life will result.

4. Check for any wires and/or copper tubing that may have been pushed out of place.
5. Install and adjust belt to the proper tension (Figure 71).

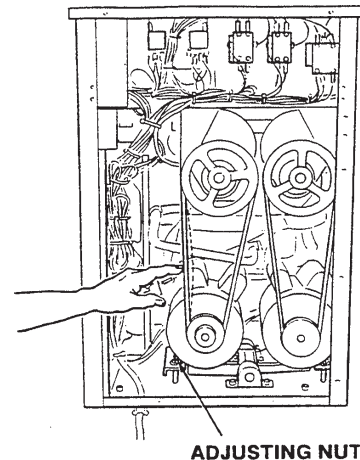

Figure 71. Belt Tension Adjustment

5.28 COMPRESSOR

The compressor is designed specifically for use with R404A. It has an internal high-pressure bypass. This eliminates the need for a high-pressure cutout switch on air-cooled models; water-cooled models will have a high-pressure cutout switch.

5.29 COMPRESSOR REMOVAL

1. Remove the compressor terminal cover by inserting a standard screwdriver between the terminal cover and the compressor cover frame, then gently pry off from the right side, then the left (Figure 72).

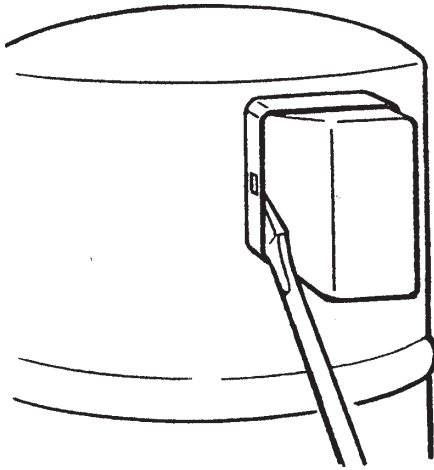

Figure 72. Compressor Cover Removal

2. Identify and remove the three wires from the inside of the compressor electrical box (Figure 73).



Figure 73. Compressor Connections

3. Reclaim the refrigerant charge, then leave a port open to prevent pressure buildup during compressor removal.

4. Remove 6" of insulating tubing on the suction line going to the compressor and unsweat the suction and discharge line from the compressor.
5. Remove the four nuts and washers from the base of the compressor.
6. Remove the compressor through the front of the freezer.
7. Remove any access fittings and the four rubber compressor mounts from the old compressor.

NOTE

Rubber mounts are not always furnished with replacement compressors.

8. Check the compressor for a burnout condition using an acid test kit. If acid is found, clean out the system per the compressor manufacturer's instructions (Figure 74).



Figure 74. Compressor Oil Test Kit

9. Plug all open ports of the old compressor.

NOTE

A compressor returned to the company with any open ports will void the warranty. Always plug any open ports on a compressor that has been removed.

5.30 COMPRESSOR INSTALLATION

1. Before the replacement compressor can be installed, the entire refrigeration system must be thoroughly purged.

CAUTION

IF ACID HAS BEEN FOUND IN THE COMPRESSOR SYSTEM. CLEAN OUT PER THE COMPRESSOR MANUFACTURER'S INSTRUCTIONS.

2. Remove all plugs from the replacement compressor.
3. Install any access fittings and the four rubber compressor mounts on the replacement compressor.
4. Install the replacement compressor into the freezer fitting the base over the four studs.
5. Install the four washers and nuts onto the studs and tighten securely.
6. Leaving the port open to prevent pressure buildup, braze the suction and discharge line to the compressor.
7. Connect the wires in the compressor electrical box and install the electrical box cover.
8. Purge and evacuate the refrigeration system to 50 microns of mercury for approximately 30 minutes.
9. Break the vacuum to (0 P.S.I.G.) through the low side Schrader valve with dry nitrogen.
10. Remove the old filter drier and install a new filter drier using the appropriate brazing material (Figure 75).

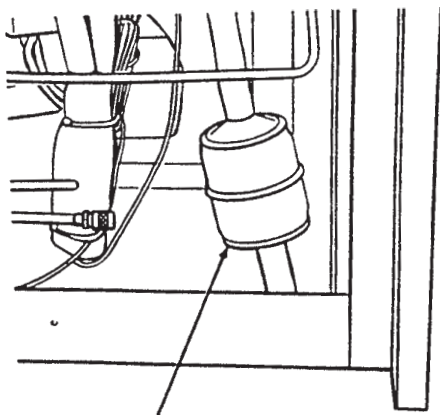

**FILTER
DRIER**

Figure 75. Filter Drier

11. Purge and evacuate the refrigeration system to 50 microns of mercury for approximately 30 minutes.
12. Accurately charge the system with R22 per the amount indicated on the specification tag located on the top front of the right side panel.
13. Leak check all fittings and connections.
14. Replace the 6" of insulating tubing to the suction line.

5.31 FINAL ASSEMBLY OF FREEZER

Upon completion of the removal and installation of any or all of the major components of the freezer, the panels must be replaced by performing the following procedures:

1. Position the back panel into place and install the two Phillips head screws through the back panel and tighten securely.
2. Position the right side panel (with nameplate) into place and install the Phillips head screw through the bottom of the side panel and tighten securely.
3. Position the left side panel into place and install the Phillips head screw through the bottom of the side panel and tighten securely.
4. Position the front panel into place and install the two Phillips head screws through the bottom of the front panel and tighten securely.
5. The freezer electrical supply can now be connected.

SECTION 6 TROUBLESHOOTING

Troubleshooting can be difficult. The TROUBLESHOOTING INDEX below gives a list of possible problems. To make a repair to a problem, make reference to the cause and correction on the page indicated. ALL REPAIRS MUST BE MADE BY A QUALIFIED SERVICE TECHNICIAN.

This list of problems, causes and corrections will only give an indication of where a possible problem can be and what repairs are needed. Normally, more or other repair work is needed beyond the recommendations in the list.

Remember that a problem is not normally caused by only one part, but by the relation of one part with other parts. This list is only a guide and cannot give all possible problems and corrections. The technician must find the problem and its source, then make the necessary repairs.

Any problem correction proceeded with an asterisk (*) may require refrigeration system repair. Refrigerant recovery, refrigeration system repair and handling/disposal of defective refrigeration components shall be in compliance with Environmental Protection Agency requirements per the provisions of the U.S. Clean Air Act.

In the event the Troubleshooting Guide does not help to correct the service problem, the factory Service Department should be contacted. Contact:

STOELTING, INC.

502 Hwy. 67

Kiel, WI 53042

Phone: 920-894-2293

Fax: 920-894-7029

<u>Subsection & Title</u>	<u>Problem</u>		<u>Page</u>
	<u>No.</u>	<u>Problem Description</u>	
6.1 Dispensing, Servability and Overrun	6.1.1	Product dispenses slowly or not at all	6-2
	6.1.2	Product is too soft	6-2
	6.1.3	Low overrun	6-3
	6.1.4	Mix spray when spigot is opened	6-3
6.2 Barrel and Hopper Mix Temperature Maintenance	6.2.1	Hopper temperature is too warm	6-3
	6.2.2	Frozen product on hopper walls	6-4
	6.2.3	Overnight barrel meltdown did not occur	6-4
	6.2.4	Overnight barrel temperature is too warm	6-4
6.3 Electro-Mechanical	6.3.1	Freezer starts immediately after power is turned on	6-4
	6.3.2	Freezer will not start after power is turned on	6-5
	6.3.3	Red CLEAN light is flashing	6-5
	6.3.4	HOLD READY switch will not work	6-5
	6.3.5	Compressor will not start	6-5
	6.3.6	Compressor will not start: hums but trips on overload protector	6-5
	6.3.7	Compressor starts, but remains on start winding	6-5
	6.3.8	Compressor starts and runs, but short cycles on overload protector	6-6
	6.3.9	Compressor start capacitor open, shorted or blown	6-6
	6.3.10	Compressor run capacitor open, shorted or blown	6-6
	6.3.11	Compressor start relay defective or burned out	6-6
	6.3.12	Compressor will not run but drive motor runs	6-6
	6.3.13	Freezer refreezes too often in green light mode	6-6
	6.3.14	Freezer operates too long or continuously	6-7
	6.3.15	Freezer is noisy	6-7

	6.3.16	Freezer will not leave present mode	6-7
	6.3.17	Touch Pad lights do not work; freezer operates normally	6-7
	6.3.18	Compressor discharge pressure too high	6-8
	6.3.19	Compressor running too hot; trips on overload protector	6-8
	6.3.20	Compressor suction pressure too high	6-8
	6.3.21	Compressor suction pressure too low	6-9
	6.3.22	Freezer refrigerant charge is low	6-9
6.4	Control Displayed Error Conditions	6.4.1 Error 01: Program Module	6-9
		6.4.2 Error 02: Power Board	6-10
		6.4.3 Error 03: Low Torque Error	6-10
		6.4.4 Error 04: CLEAN error	6-10
		6.4.5 Error 05: Barrel Sensor	6-10
		6.4.6 Error 06: Hopper Sensor	6-10
		6.4.7 Error 07: Drive Motor	6-10

6.1 DISPENSING, SERVABILITY AND OVERRUN

6.1.1 PRODUCT DISPENSES SLOWLY OR NOT AT ALL

CAUSE	CORRECTION
No mix or very low mix in hopper.	Add prechilled mix into hopper.
Mix inlet regulator orifice is too small.	Use larger orifice, especially for thicker mixes.
Mix inlet regulator is plugged.	Unplug using small sanitized brush or disassemble, and sanitize all mix regulator parts.
Freezer is being overdrawn.	Slow down rate of draw.
Consistency setting is too soft or too firm.	Adjust fine consistency potentiometer accordingly. If more adjustment is required, increase/decrease coarse amperage 'AMP CRS' setting 0.5 amps with fine potentiometer at midrange consistency procedure in subsection.
Hopper mix partially frozen, improperly thawed.	Thaw mix according to manufacturer's instructions.
Door handle movement is too restricted.	Turn dispense rate adjuster counterclockwise.
Door port is blocked or frozen.	Turn off power, remove door and frozen product/blockage. Prepare mix according to manufacture's instructions.
Auger flights and/or springs are worn or missing.	Replace flights and/or springs.
Control 'LKG' temperature is too high/low.	Control 'LKG' temperature should approximately equal or slightly exceed desired product serving temperature; change accordingly (refer to control setup procedure in subsection 3.2).
Freezer refrigerant charge is low.	*Refer to Troubleshooting subsection 6.3.22.
Suction line solenoid valve has excessive seat leakage; barrel is frozen.	*Replace the suction line solenoid valve.
Auger shaft not turning.	Check and replace belt, speed reducer or auger shaft.

6.1.2 PRODUCT IS TOO SOFT (SEE MIX CHARACTERISTICS SECTION)

CAUSE	CORRECTION
Dispensed product with red P.T.F. light.	Dispense servable product with green P.T.F. illuminated.
Ambient temperature is high.	Move or direct hot air away from freezer.
Mix inlet regulator air tube is plugged.	Unplug by using small sanitizes brush.
Freezer is being overdrawn.	Slow down rate of draw.
Consistency setting is too soft or too firm.	Adjust fine consistency potentiometer firmer. If more adjustment is required, increase coarse amperage 'AMP CRS' setting 0.5 amps accordingly with fine potentiometer at mid-range (refer to control setup procedure in subsection 3.2). If unable to establish desired consistency, follow the coarse amperage consistency procedure in subsection 3.2.

Control 'LKG' temperature is too high/low.	Control 'LKG' temperature should approximately equal or slightly exceed the desired product serving temperature; change accordingly (refer to control setup procedure in subsection 3.2).
Mix inlet regulator leaking air and/or mix.	Check and/or replace missing, worn, or damaged o-rings and floating check balls. Lubricate o-rings accordingly.

NOTE

Avoid lubrication of check balls. Check balls must float freely.

Warm mix in hopper.	Use prechilled mix in hopper.
Condenser and/or condenser filter is dirty.	Clean condenser and/or filter.
Freezer operating in HOLD READY mode with low usage (product breakdown).	If time permits, turn power OFF, then ON to place freezer into standby mode. Barrel meltdown will immediately begin and should be complete in approximately 3 hours.
.....	-OR-
.....	Clean and refill with fresh product.
Product breakdown.	Same as above.
Fan or fan motor is defective.	Check, repair or replace.

6.1.3 LOW OVERRUN

CAUSE

CORRECTION

Mix inlet regulator air tube is plugged.	Unplug by using small sanitized brush.
Mix inlet regulator leaking air and/or mix.	Check and/or replace missing, worn or damaged o-rings and floating check balls. Lubricate o-rings accordingly.

NOTE

Avoid lubrication of check balls. Check balls must float freely.

Legs are loose or freezer is not level.	Check legs, level top of freezer.
Mix inlet regulator is being removed during Freezing.	Do not remove mix inlet regulator during freezing.
Auger flights and/or springs are worn or missing.	Replace flights and/or springs.
Incorrect use of overrun scale.	Refer to Mix Characteristics section.
Product breakdown.	Clean freezer, use new mix.

6.1.4 MIX SPRAY WHEN SPIGOT IS OPENED

CAUSE

CORRECTION

Slightly elevated pressure in the barrel after meltdown is maintained by the mix inlet regulator check balls.	Open spigot slowly to relieve the elevated pressure in the barrel before dispensing product.
--	--

6.2 BARREL AND HOPPER MIX TEMPERATURE MAINTENANCE

6.2.1 HOPPER TEMPERATURE IS TOO WARM

CAUSE

CORRECTION

Warm mix in hopper.	Use prechilled mix in hopper.
Not using insulated cover.	Use insulated cover.
E.P.R. valve needs adjusting.	Make appropriate adjustment. Refer to Refrigeration Section 4, Subsection 4.10
Ambient temperature is very warm.	Move or direct hot air away from freezer.
Control 'STB' temperature is too high.	Lower the 'STB' temperature 2° to 4°F accordingly. (Refer to setup procedure.)
Cap tube is partially or completely blocked.	*Check if E.P.R. valve setting can be achieved during freezing. If not, replace the cap tube.
Freezer refrigerant charge is low.	*Refer to Troubleshooting Subsection 6.3.22

6.2.2 FROZEN PRODUCT ON HOPPER WALLS

CAUSE	CORRECTION
Heavy freezer usage	There is no correction required if the E.P.R. valve setting is correct. Some product freezing to the walls during heavy freezer operation is normal.
E.P.R. valve needs adjusting.	Make appropriate adjustment. Refer to Refrigeration Section 4, Subsection 4.10.

6.2.3 OVERNIGHT BARREL MELTDOWN DID NOT OCCUR

CAUSE	CORRECTION
Unit left in HOLD READY mode	If time permits, turn power OFF, then ON to place freezer into standby mode. Barrel meltdown will immediately begin and should be complete in approximately 3 hours.
.....	-OR-
.....	Clean and refill with fresh product.
Freezer nonusage timespan is too short for complete meltdown	Freezer nonusage period is approximately eight (8) hours to assure a complete barrel meltdown.
Control idle (standby) 'STB' temperature is too low	Raise the idle temperature 3.2°F (refer to control setup procedure in subsection 3.2).
Liquid line solenoid valve failed to open	*Replace liquid line solenoid valve coil or entire valve.
Cap tube is partially or completely blocked	*Check if E.P.R. valve setting can be achieved during freezing. If not, replace the cap tube.

6.2.4 OVERNIGHT BARREL TEMPERATURE IS TOO WARM

CAUSE	CORRECTION
Control idle (standby) 'STB' temperature is too high	Lower the idle temperature 2° to 4°F (refer to control setup procedure in subsection 3.2).

6.3 ELECTRO-MECHANICAL

6.3.1 FREEZER STARTS IMMEDIATELY AFTER POWER IS TURNED ON

CAUSE	CORRECTION
The barrel sensed temperature exceeds the idle (standby) 'STB' temperature plus the 'LKG STB' value.	None required. This is proper freezer operation. Freezing will continue until the barrel sensed temperature equals the idle temperature less the 'LKG STB' value. The freezer is in standby mode at this time.

6.3.2 FREEZER WILL NOT START AFTER POWER IS TURNED ON

CAUSE	CORRECTION
Freezer is unplugged	Plug in freezer.
Blown fuse or tripped circuit breaker in building	Check for blown fuse or tripped circuit breaker in building and replace.
Side panel is removed	Install side panel or pull out side panel interlock switch plunger.
Door is removed	Install door.
Door pin is missing or broken	Replace the door pin.
Door interlock switch requires adjustment	Adjust switch so door pin activates the switch.
Unit is in an ERROR condition	Refer to Troubleshooting Subsection 6.4.
OFF/ON switch has a loose wire or is defective	Check, repair or replace switch.

6.3.3 RED CLEAN LIGHT IS FLASHING

CAUSE	CORRECTION
CLEAN was deactivated by depressing the CLEAN switch; control is awaiting your next command	Turn power OFF then ON to leave CLEAN mode or depress CLEAN again to continue CLEAN mode operation.

6.3.4 HOLD READY SWITCH WILL NOT WORK

CAUSE	CORRECTION
The HOLD READY switch has not been held depressed for 5 seconds to activate or deactivate HOLD READY mode	Depress and keep the HOLD READY switch depressed for 5 seconds to activate or deactivate HOLD READY mode.
Switch has a loose wire or is defective	Check, repair or replace the switch.

6.3.5 COMPRESSOR WILL NOT START

CAUSE	CORRECTION
Low voltage to unit	Determine reason and correct.
Wiring improper or loose	Check against diagram.
Line disconnect, switch open	Close start or disconnect switch.
8-Pin relay defective	Replace 8-pin relay. (E131 & F131 only)
Compressor contactor defective	Replace contactor.
Start relay failing to close	Determine reason and correct; replace is defective.
Start capacitor defective	Determine reason and replace.
Overload protector tripped	Will reset after cooling.
Overload protector defective	Replace overload protector. (E111 & F111 only)
Excessively high discharge pressure	*Refer to Troubleshooting Subsection 6.3.18.
Internal mechanical trouble in compressor	*Replace compressor.

6.3.6 COMPRESSOR WILL NOT START; HUMS BUT TRIPS ON OVERLOAD PROTECTOR

CAUSE	CORRECTION
Low voltage to unit	Determine reason and correct.
Improperly wired	Check wiring against diagram.
Start relay failing to close	Determine reason and correct. Replace relay if defective.
Capacitor defective	Check start/run capacitor. Replace if defective.
Excessively high discharge pressure	*Refer to Troubleshooting Subsection 6.3.18.
Overload protector defective	Replace overload protector.
Compressor motor has a winding open or shorted	*Replace compressor.
Internal mechanical trouble in compressor	*Replace compressor.

6.3.7 COMPRESSOR STARTS, BUT REMAINS ON START WINDING

CAUSE	CORRECTION
Low voltage to unit	Determine reason and correct.
Improperly wired	Check wiring against diagram.
Start relay failing to close	Determine reason and correct. Replace relay if necessary.
Run capacitor defective	Determine reason and replace.
Excessively high discharge pressure	*Refer to Troubleshooting Subsection 6.3.18.
Compressor motor has a winding open or shorted	*Replace compressor.
Internal mechanical trouble in compressor	*Replace compressor.

6.3.8 COMPRESSOR STARTS AND RUNS, BUT SHORT CYCLES ON OVERLOAD PROTECTOR

CAUSE	CORRECTION
Low voltage to unit	Determine reason and correct.
Improperly wired	Check wiring against diagram.
Overload protector defective	Replace overload protector.
Capacitor defective	Check start/run capacitor. Replace if defective.
Excessively high discharge pressure	*Refer to Troubleshooting Subsection 6.3.18.
Compressor too hot	*Refer to Troubleshooting Subsection 6.3.19.
Excessively low suction pressure	*Refer to Troubleshooting Subsection 6.3.21.
Excessively high suction pressure	*Refer to Troubleshooting Subsection 6.3.20.
Compressor motor has shorted	*Replace compressor.

6.3.9 COMPRESSOR START CAPACITOR OPEN, SHORTED OR BLOWN

CAUSE	CORRECTION
Loose wires.	Locate and correct.
Start relay failure.	Replace start relay.
Excessively short cycling.	Determine reason and correct.
Improper capacitor.	Determine correct size and replace.
Prolonged operation on start cycle due to low voltage to unit.	Refer to Troubleshooting Subsection 6.3.7.

6.3.10 COMPRESSOR RUN CAPACITOR OPEN, SHORTED OR BLOWN

CAUSE	CORRECTION
Excessively high line voltage (110% of rated max.).	Contact your local power company.
Improper capacitor.	Determine correct size and replace.
Compressor relay incorrectly mounted.	Remount relay in correct position.

6.3.11 COMPRESSOR START RELAY DEFECTIVE OR BURNED OUT

CAUSE	CORRECTION
Incorrect start relay.	Check and replace.
Incorrect mounting angle.	Remount relay in correct position.
Line voltage too high or too low ($\pm 10\%$).	Contact your local power company.
Excessively short cycling.	Determine reason and correct.
Relay being influenced by loose vibrating mounting.	Remount rigidly.
Incorrect run capacitor.	Replace with proper capacitor.

6.3.12 COMPRESSOR WILL NOT RUN, BUT DRIVE MOTOR RUNS

CAUSE	CORRECTION
Normal barrel stir cycle.	No correction required.
Power module defective.	Replace power module.
8-Pin relay defective.	Replace 8-pin relay. (E131 & F131 only)
Compressor contactor defective.	Replace contactor.
Program module defective.	Replace program module.
Compressor problem.	Refer to Troubleshooting Subsection 6.3.5 through 6.3.11.

6.3.13 FREEZER REFREEZES TOO OFTEN IN GREEN LIGHT MODE

CAUSE	CORRECTION
Ambient temperature is high	Move or direct hot air away from freezer.
Control 'LKG' temperature is too high/low	Control 'LKG' temperature should approximately equal or slightly exceed the desired product serving temperature; change accordingly (refer to control setup procedure in subsection 3.2).
Liquid line solenoid valve has excessive seat leakage	*Replace the liquid line solenoid valve.

6.3.14 FREEZER OPERATES TOO LONG OR CONTINUOUSLY

CAUSE	CORRECTION
Improper freezer air clearance	Remove airflow restrictions. Maintain adequate clearances.
Ambient temperature is high	Move or direct hot air away from freezer.
No mix or very low mix in hopper	Add prechilled mix into hopper.
Mix inlet regulator orifice is too small	Use larger orifice, especially for thicker mixes.
Mix inlet regulator is plugged	Unplug using small sanitized brush or disassemble, clean and sanitize all mix regulator parts.

NOTE

Avoid lubrication of check balls. Check balls must float freely.

Consistency setting is too firm	Adjust fine consistency potentiometer firmer. If more adjustment is required, increase coarse amperage 'AMP CRS' setting 0.5 amps accordingly with fine potentiometer at mid-range (refer to control setup procedure in subsection 3.2). If unable to establish desired consistency, follow the coarse amperage consistency procedure in subsection 3.2.
Spigot switch out of adjustment or defective	Adjust or replace spigot switch.
Condenser and/or filter is dirty	Clean condenser and/or filter.
Auger flights and/or springs are worn or missing	Replace flights and/or springs.
Hopper mix partially frozen and improperly thawed	Thaw mix properly per manufacturer's instructions.
Unit left in HOLD READY mode with low usage (product breakdown)	If time permits, turn power OFF, then ON to place freezer into standby mode. Barrel meltdown will immediately begin and should be complete in approximately 3 hours.
.....	-OR-
.....	Clean and refill with fresh product.
Product breakdown	Same as above.
Defective liquid line solenoid valve	*Replace coil and/or liquid line solenoid valve.
Freezer refrigerant charge is low	*Refer to Troubleshooting Subsection 6.3.22.
Condenser fan and/or motor is defective	Replace fan and/or motor.
Expansion valve is defective or grossly out of adjustment	Replace the expansion valve. Do not adjust the expansion valve.
Refrigeration system problem	*Refer to Troubleshooting Subsection 6.3.18 through 6.3.22.

6.3.15 FREEZER IS NOISY

CAUSE	CORRECTION
Legs are loose or freezer is not level.	Check legs, level top of freezer.
Loose parts or mounting.	Find and tighten
Defective drive belt.	Replace drive belt.
Tubing rattle.	Reform to be free of contact.
Bent fan causing vibration.	Replace fan.
Fan motor bearings worn.	Replace motor.
Internal compressor spring broken.	Replace compressor.
Speed reducer bearings or gears faulty.	Replace speed reducer.

6.3.16 FREEZER WILL NOT LEAVE PRESENT MODE

CAUSE	CORRECTION
Loose or defective touch pad connection.	Repair the touch pad connection.

6.3.17 TOUCH PAD LIGHTS DO NOT WORK: FREEZER OPERATES NORMALLY

CAUSE	CORRECTION
Touch pad defective	Replace touch pad.
Loose or improper connections to the touch pad	Check and repair the touch pad connections.
Control logic board is defective	Replace control logic board.

6.3.18 COMPRESSOR DISCHARGE PRESSURE TOO HIGH

CAUSE	CORRECTION
Improper freezer air clearance	Remove airflow restrictions. Maintain adequate clearances.
Freezer located near heat source	Move or direct hot air away from freezer.
Ambient temperature is high	Same as above.
Freezer discharge air recirculating into condenser intake	Eliminate recirculating using Stoelting top rear air discharge plenum.
Dirty condenser and/or filter	*Clear condenser.
Entering water temperature to water-cooled condenser is excessively high	Determine cause and correct.
Condenser fan and/or fan motor is defective	Replace fan and/or fan motor.
Discharge line, condenser tube, or condenser U-bend restriction (especially in top half of condenser)	*Repair restriction.
Water valve out of adjustment	Make appropriate adjustment. Refer to Refrigeration Section 4 Subsection 4.22.
Dirt or restriction on waterside of water-cooled condenser or connecting water lines	Flush condenser and lines thoroughly.
Refrigerant overcharge	*Recover charge. Evacuate and recharge per nameplate by weight-ounces.
Air or noncondensable gases in refrigeration system	*Same as above.

6.3.19 COMPRESSOR RUNNING TOO HOT: TRIPS ON OVERLOAD PROTECTOR

CAUSE	CORRECTION
Excessively high discharge pressure	Refer to Troubleshooting Subsection 6.3.18.
Suction line insulation loose or missing	Re-insulate suction lines.
Expansion valve setting grossly out of adjustment	*Replace expansion valve.

NOTE

*Expansion valve setting is preset for optimum balance of flow to barrel and hopper-
DO NOT ATTEMPT TO ADJUST THE VALVE SETTING.*

Internal mechanical trouble in compressor	*Replace compressor.
---	----------------------

6.3.20 COMPRESSOR SUCTION PRESSURE TOO HIGH

CAUSE	CORRECTION
Expansion valve setting grossly out of adjustment	*Replace expansion valve.

NOTE

*Expansion valve setting is preset for optimum balance of flow to barrel and hopper-
DO NOT ATTEMPT TO ADJUST THE VALVE SETTING.*

Refrigerant overcharge	*Recover charge. Evacuate and recharge per nameplate by weight-ounces.
Internal mechanical trouble in compressor	*Replace compressor.

6.3.21 COMPRESSOR SUCTION PRESSURE TOO LOW

CAUSE	CORRECTION
Consistency setting is too firm.	Adjust fine consistency potentiometer firmer. If more adjustment is required, increase coarse amperage 'AMP CRS' setting 0.5 amps accordingly with fine potentiometer at mid-range (refer to control setup procedure in subsection 3.2). If unable to establish desired consistency, follow the coarse amperage consistency procedure in subsection 3.2.
Expansion valve setting grossly out of adjustment	*Replace expansion valve.

NOTE

*Expansion valve setting is preset for optimum balance of flow to barrel and hopper-
DO NOT ATTEMPT TO ADJUST THE VALVE SETTING.*

Expansion valve orifice is plugged or valve is defective.	Same as above.
Defective liquid line solenoid valve	*Replace coil and/or liquid line solenoid valve.
Freezer refrigerant charge is low	*Refer to Troubleshooting Subsection 6.3.22.

6.3.22 FREEZER REFRIGERANT CHARGE IS LOW

CAUTION

A FALSE DIAGNOSIS OF A SHORTAGE OF REFRIGERANT CHARGE IS POSSIBLE IN MODEL E131 AND F131 FREEZERS. IF ONLY ONE SIDE IS OPERATIONAL, THE INOPERATIVE SIDE MAY CONTAIN A SIGNIFICANT PERCENTAGE OF THE TOTAL SYSTEM CHARGE. THIS CAN ALSO OCCUR IF BOTH SIDES ARE OPERATIONAL BUT ONE SIDE IS IN IDLE MODE AND THE OTHER IN GREEN LIGHT MODE. THE SYSTEM SIGHTGLASS DURING OPERATION OF THE GREEN LIGHT/OPERATIVE SIDE MAY SHOW BUBBLES OR A PARTIALLY EMPTY CONDITION EVEN THOUGH THE TOTAL SYSTEM IS PROPERLY CHARGED. THE GREEN LIGHT/OPERATIVE SIDE WILL OPERATE BOTH SIDES OF THE FREEZER AND IN THE SAME MODE AS MUCH AS POSSIBLE. FURTHERMORE, TEST STEPS 1 AND 2 BELOW MUST BE CONDUCTED WITH SIMULTANEOUS OPERATION OF BOTH SIDES.

CAUSE	CORRECTION
Leak(s), prolonged use of gauges or frequent usage of gauges.	DO NOT ADJUST THE EXPANSION VALVE!
.....	STEP 1: Observe sightglass for bubbles during refreeze. If sightglass is bubbling or partially empty, freezer refrigerant charge is low. (SEE CORRECTION BELOW). If sightglass is clear, proceed to Step 2.

..... **STEP 2:** Empty barrel and hopper of all product. Rinse hopper
 and barrel with cool water using a sanitized bucket. Refill freezer
 with 35° to 45° mix until hopper is full with mix inlet regulator in
 place. Upon freeze-down, the sightglass should clear within the
 first 60 seconds of operation. If sightglass is bubbling or partially
 empty after 60 seconds, the freezer refrigerant charge is low.
 **CORRECTION:** *Recover refrigerant. Check and repair leaks.
 Evacuate and recharge per nameplate by weight-ounces.

6.4 CONTROL DISPLAYED ERROR CONDITIONS

6.4.1 ERROR 01: PROGRAM MODULE

(P.T.F. LIGHT FLASHES IN SEQUENCE OF ONE)

CAUSE	CORRECTION
Program module is defective.	Replace the program module.

6.4.2 ERROR 02: POWER BOARD

(P.T.F. LIGHT FLASHES IN SEQUENCE OF TWO)

CAUSE	CORRECTION
Low AC input voltage.	Check line voltage. Contact your local power company if necessary.
Low DC output voltage.	Replace power board.

6.4.3 ERROR 03: LOW TORQUE ERROR

(P.T.F. LIGHT FLASHES IN SEQUENCE OF THREE)

NOTE

Freezer ran 20 consecutive minutes without reaching consistency shutoff. Refer to Troubleshooting Subsection 6.3.14 for possible causes.

6.4.4 ERROR 04: CLEAN ERROR

(P.T.F. LIGHT FLASHES IN SEQUENCE OF FOUR)

CAUSE	CORRECTION
Freezer ran in CLEAN mode for 30 consecutive minutes.	Allow freezer to remain on with the power switch in the ON position for ten (10) minutes minimum. Next, place the power switch in the OFF position for five (5) seconds minimum, then place the power switch in the ON position to restart the freezer.
.....	CLEAN switch was activated three (3) times in
Ten (10) seconds.	Same as above.

6.4.5 ERROR 05: BARREL SENSOR

(P.T.F. LIGHT FLASHES IN SEQUENCES OF FIVE)

CAUSE	CORRECTION
Sensed temperature limits exceeded.	Restore normal temperatures.
Open or shorted leads to the sensor.	Repair leads.
Open or shorted sensor.	Replace sensor.

6.4.6 ERROR 06: HOPPER SENSOR

(P.T.F. LIGHT FLASHES IN SEQUENCE OF SIX)

CAUSE	CORRECTION
Open sensor leads to program module.	Repair leads.
Open or shorted leads to the sensor.	Repair leads.
Open or shorted sensor.	Replace sensor.

6.4.7 ERROR 07: DRIVE MOTOR

(P.T.F. LIGHT FLASHES IN SEQUENCE OF SEVEN)

CAUSE	CORRECTION
Drive motor overload is open.	Determine cause for overload. Wait 15 to 20 minutes for auto-
.....	matic reset of overload. Turn power OFF then ON to clear error
.....	condition. If not cleared, repeat this procedure until the error
.....	condition is cleared.
No voltage to drive motor.	Restore voltage to drive motor.
Faulty drive motor.	Replace drive motor.
No current is sensed by power board.	Restore drive motor lead through power board toroid.

SECTION 7 REPLACEMENT PARTS

7.1 HOW TO ORDER PARTS

To assure receipt of the proper replacement parts, supply your dealer or distributor with the following information:

A. Model number of equipment.

B. Serial number of model, stamped on nameplate.

C. Part number, part name and quantity needed. Common part names and numbers are listed in this manual.

Part Number	Description
208135	Brush, Nylon: 16" x 4", Wooden Handle
208380	Brush, Nylon: 14" x 1/4", Wire Handle
208401	Brush, Nylon: 10" x 1", Wire Handle
208467	Brush, Nylon: 5-1/4" x 3/8", Wire Handle
3157992	Model ID Plate
324594	Heat Sensitive
324107	Caution, Hazardous Moving Parts
324105	Danger, Electric Shock Hazard
324106	Caution, Electric Wiring Materials
324141	Caution, Hazardous Rotating Blades
324584	Adequate Ventilation
324371	Decal, Time Delay Fuse

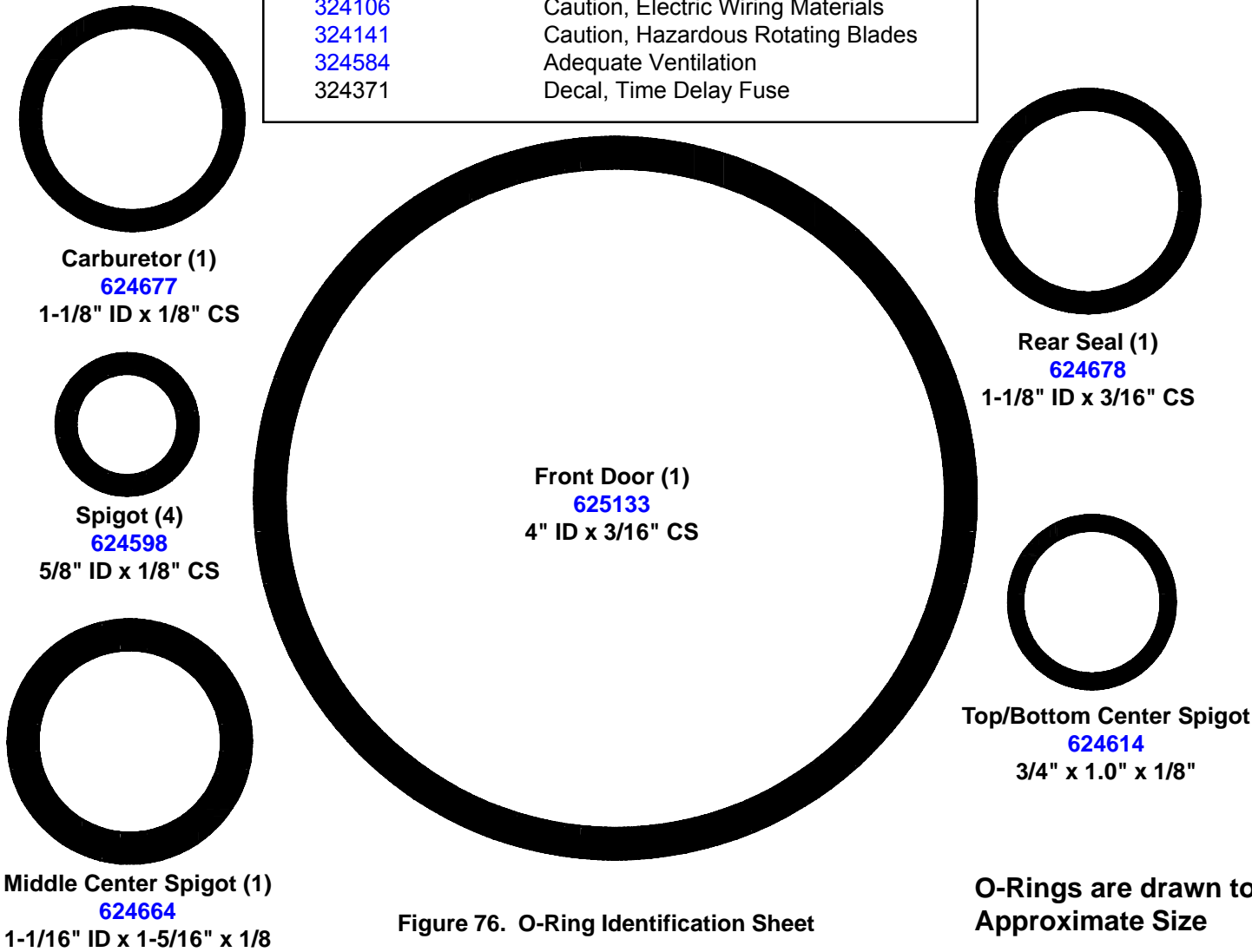
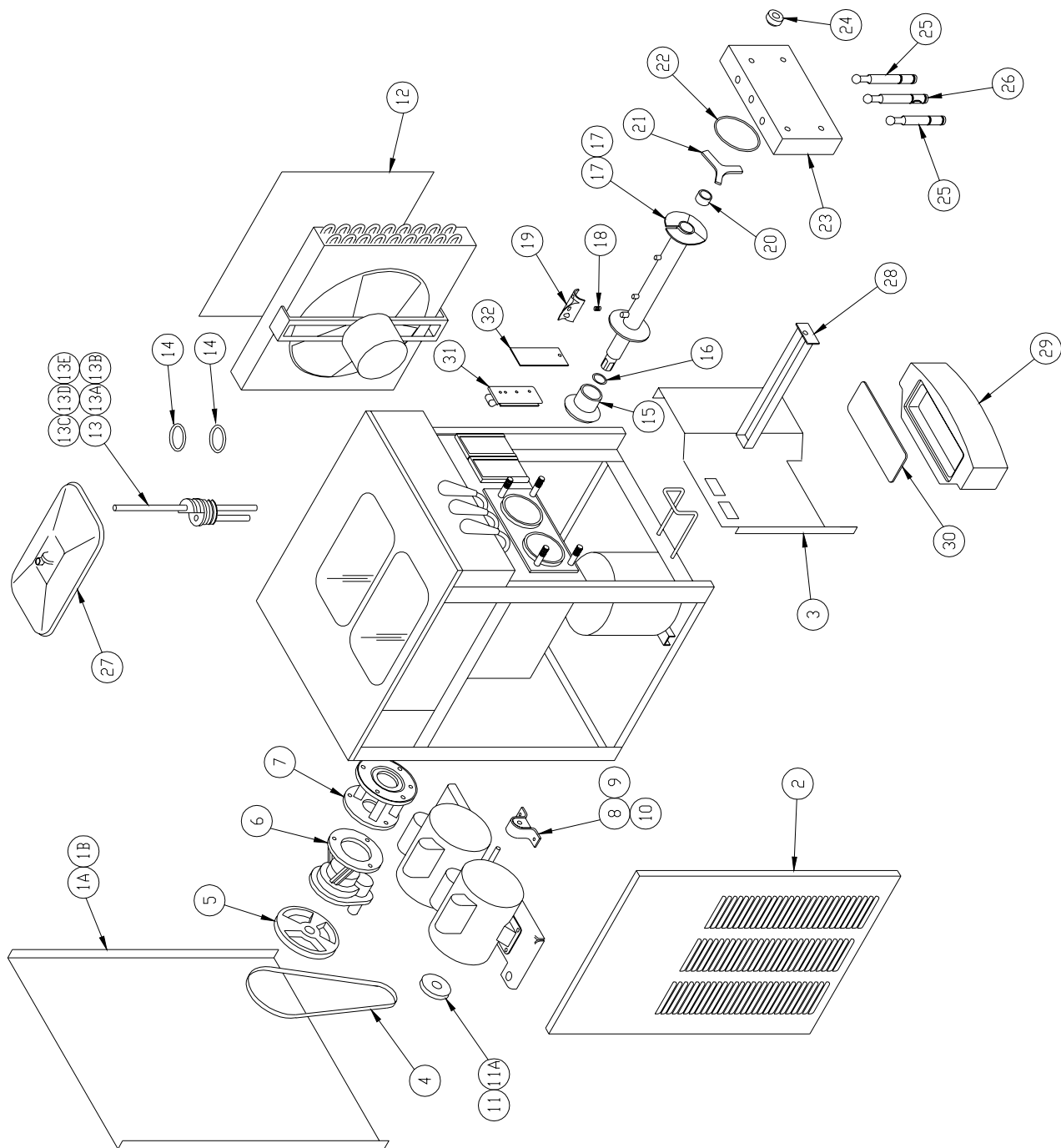
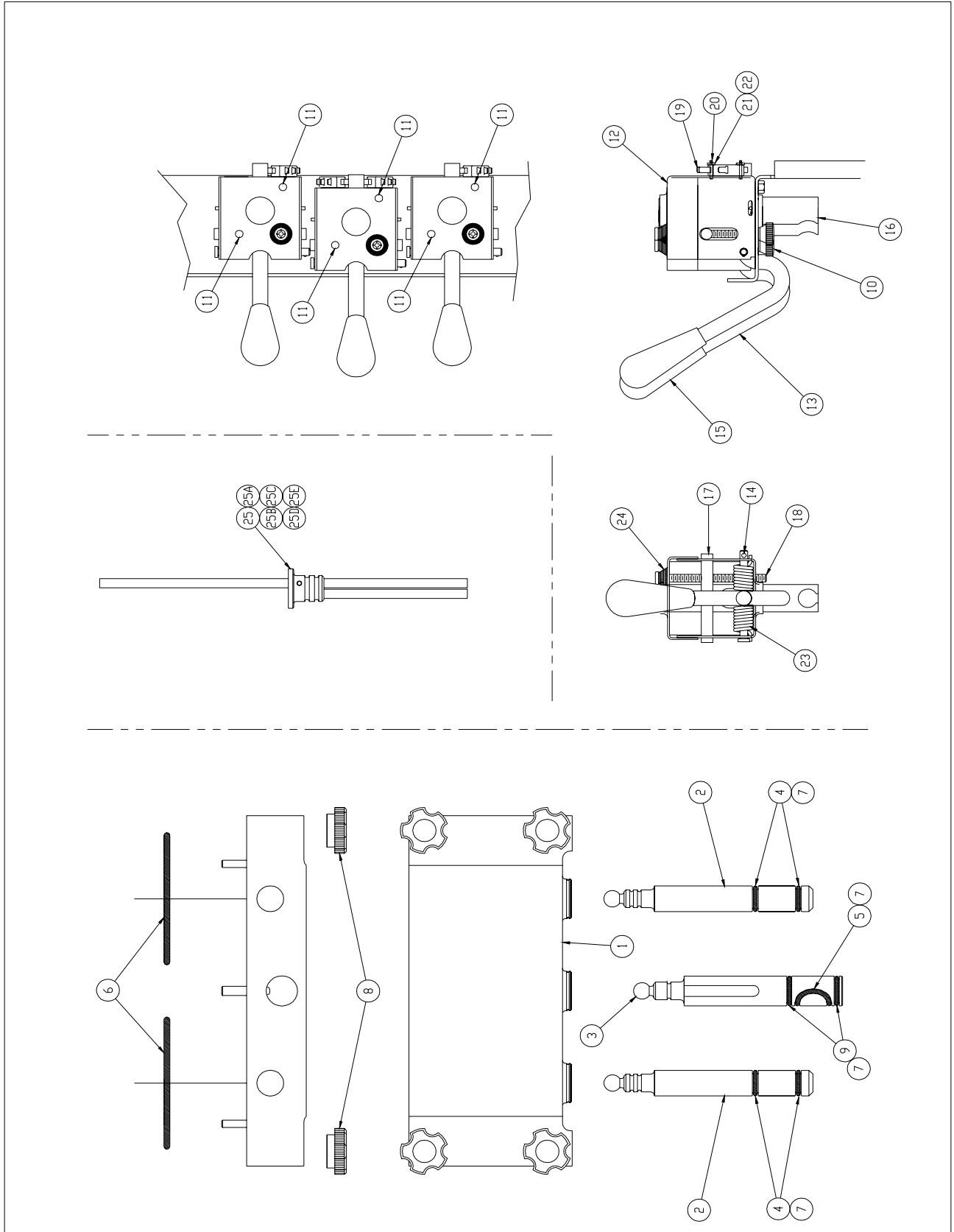

Figure 76. O-Ring Identification Sheet



ITEM	STOELTING PN	QTY	DESCRIPTION
1A	3158201-SV	1	BACK PANEL (A/C ONLY)
1B	3159551-SV	1	BACK PANEL (W/C ONLY)
2	3157964-SV	2	SIDE PANEL
3	4158304-SV	1	LOWER FRONT PANEL
4	152322	2	V-BELT
5	598245	2	PULLEY
6	614233	2	GEAR REDUCER
7	246048	2	SPACER (E131 ONLY)
8	2100737	4	MOTOR MOUNTING CLAMP
9	524028	4	MOUNT MTR HINGE PIN
10	221610	4	NYLON BUSHING
11	598100	2	PULLEY (50 HZ ONLY)
11A	598072	2	PULLEY (60 HZ ONLY)
12	368140	1	CONDENSER FILTER (A/C ONLY)
13	2149243-01	2	MIX INLET REG. (3/16" HOLE, STD LENGTH)
13A	2149242	2	MIX INLET REG. (1/4" HOLE, STD LENGTH)
13B	2149241	2	MIX INLET REG. (5/16" HOLE, STD LENGTH)
13C	2147799	2	MIX INLET REG. (3/16" HOLE, EXT LENGTH)
13D	2147879	2	MIX INLET REG. (1/4" HOLE, EXT LENGTH)
13E	2147880	2	MIX INLET REG. (5/16" HOLE, EXT LENGTH)

ITEM	STOELTING PN	QTY	DESCRIPTION
14	624677	4	RING Ø 1-1/8X1-3/8X1/8 70 DURO
15	666786	1	REAR SEAL INSTRUCTIONS
16	624678	2	O-RING
17	4157952	2	AUGER (E131 ONLY)
17A	4157968	2	AUGER (F131 ONLY)
18	694255	.	SPRING
19	381804	.	AUGER FLIGHT
20	149003	2	FRONT AUGER BEARING
21	3170644	2	FRONT AUGER SUPPORT
22	625133	2	RING Ø 4.0X4.38X.19 SILICONE
23	2177428	1	FRONT DOOR W/PINS (GRAVITY)
24	482019	4	KNOB BLACK
25	3159696	2	SPIGOT, OUTSIDE
26	3158086	1	SPIGOT, CENTER
27	314453	2	HOPPER COVER
28	744262	2	DRAIN TRAY
29	744260-SV	1	DRIP TRAY
30	744271	1	DRIP TRAY INSERT
31	718866-SV	2	SWITCH, MEMBRANE STRIP
32	521216	2	COVER MEMBRANE SWITCH HOUSING



ITEM	STOELTING PN	QTY	DESCRIPTION
1	2177428	1	FRONT DOOR W/PINS <GRAVITY>
2	3159696	2	SPIGOT, OUTSIDE
3	3158086	1	SPIGOT, CENTER
4	624598	4	RING □ 5/8X7/8X1/8 MINN RBRR
5	624664	1	O-RING 1-1/6X1-5/16X1/8 CS
6	625133	2	RING □ 4.0X4.38X.19 SILICONE
7	508135	ASREQ	LUBRICANT, PETRO-GEL 40Z.TUBES
8	482019	4	KNOB BLACK
9	624614	2	O-RING 3/4 IDX 1.0 ODX 1/8 CS
10	482004	3	KNOB
11	644094	6	SCREW CAP 1/4-20 X 1/2 SDC HD
12	4158215	3	GLIDE BRACKET WELDMENT
13	2158260	3	HANDLE - Metal Only
14	570961	3	PIN, COTTERLESS CLEVIS
15	428045	3	HANDLE, TAPERED BLACK
16	2158082	3	GLIDE
17	1158080	3	ADJUSTING BAR
18	647995	3	SCREW MACH 1/4-20 X 3-1/2 RD
19	718773	4	SWITCH, LIMIT
20	647055	8	SCREW MACH 4-40 X 5/8 RD HD ZP
21	538235	8	NUT HEX 4-40 STL ZINC PLATE
22	766917	8	WASHER, SHAKEPROOF-EXT-ZP-#4
23	696048	3	SPRING, TORSION
24	694247	3	SPRING COMP 13/16X3/8X3/4
25	2149243-01	2	MIX INLET REG. <3/16" HOLE, STD LENGTH>
25A	2149242	2	MIX INLET REG. <1/4" HOLE, STD LENGTH>
25B	2149241	2	MIX INLET REG. <5/16" HOLE STD LENGTH>
25C	2147799	2	MIX INLET REG. <3/16" HOLE EXT LENGTH>
25D	2147879	2	MIX INLET REG. <1/4" HOLE, EXT LENGTH>
25E	2147880	2	MIX INLET REG. <5/16" HOLE, EXT LENGTH>

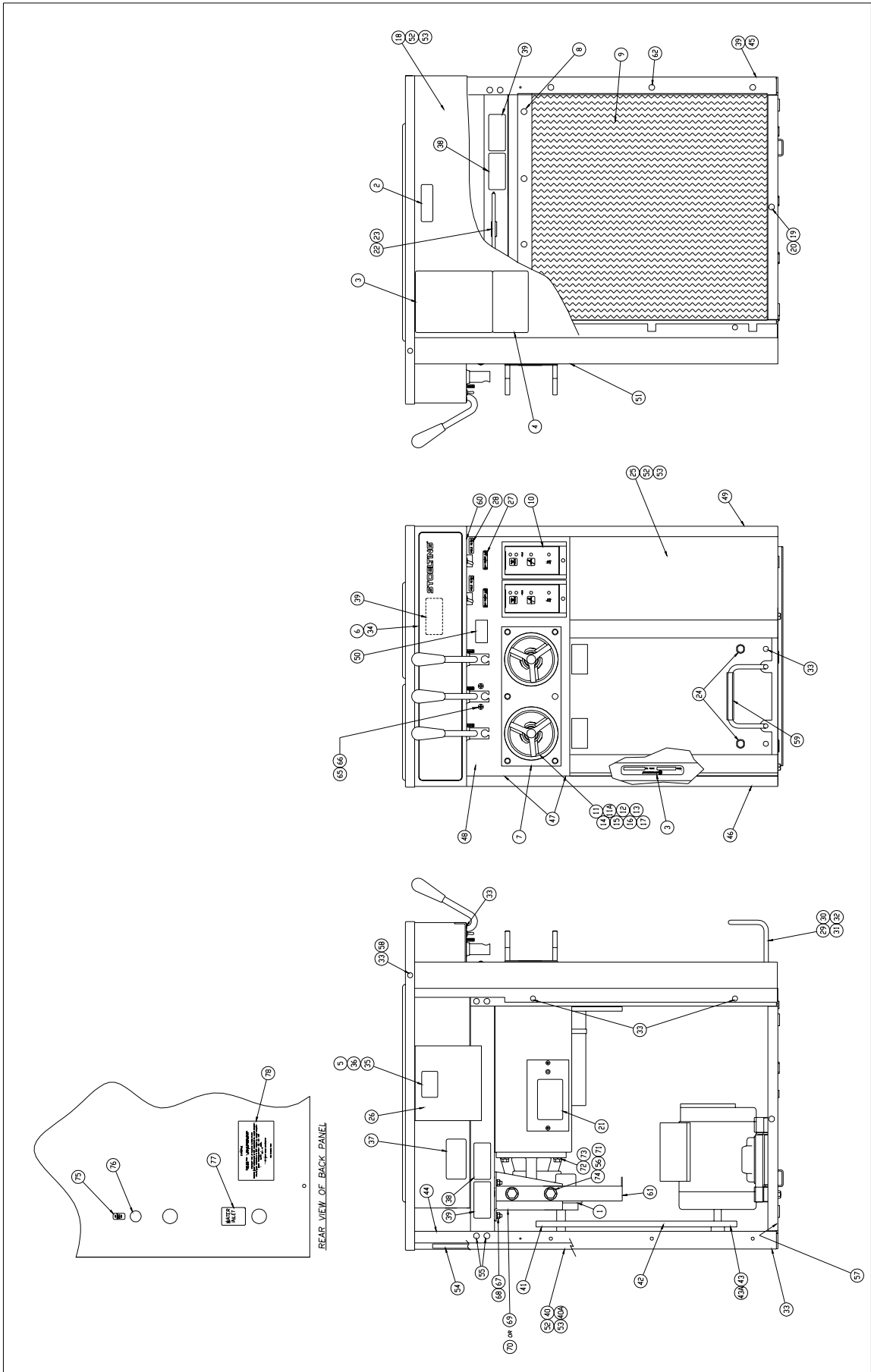

ITEM	STDELTING PN	QTY	DESCRIPTION
1	614233	2	REDUCER
2	324584	2	DECAL, ADEQUATE VENT.
3	SEE ELEC. ASSY	1	NAMEPLATE, MODEL I.D.
4	324509	1	DECAL, CLEANING INSTRUCTION
5	1157919	1	DECAL, FACTORY SETTINGS
6	324604	1	DECAL, HEADER
7	3170804	1	GASKET
8	114068	4	DOT, HOOK
9	368140	1	FILTER
10	324612	2	DECAL, CONTROL
11	4157952	2	AUGER (E131 ONLY)
11A	4157958	2	AUGER (F131 ONLY)
12	624678	2	O RING
13	666786	2	50 DURDMETER REAR SEAL
14	694255	8	SPRING
15	381804	8	FLIGHT
16	149003	2	BUSHING
17	3170544	2	FRONT AUGER SUPPORT (SPL)
18	3157964-SV	2	SIDE PANEL
19	701002	2	STANDOFF
20	649000-39	2	SCREW, SELF TAPPING #10
21	324594	2	DECAL, CAUTION USE HEAT SINK
22	266018	1	CLIP ADHESIVE BACKED *J*
23	741505	1	TOOL ALIGNMENT SCREWDRIVER
24	266076	2	CLIP, REFRIG.
25	4158304-SV	1	LOWER FRONT PANEL
26	SEE ELEC. ASSY	1	WIRING DIAGRAM
27	324593	2	DECAL - POWER
28	324592	2	DECAL - HOLD READY
29	538363	4	NUT, JAM 3/8-16
30	766464	4	WASHER, FLAT 3/8 ZP
31	766081	2	WASHER, LOCK 3/8 ZP
32	3158185	1	HANDLE
33	647653	12	SCREW, MACH 10-24 X 3/8 TRS HD
34	3158303	1	HEADER PANEL
35	130000	1	PLASTIC ENVELOPE
36	324566	1	DECAL, WIRED ACCORDING TO
37	324208	2	DECAL, ATTENTION REFRIG. LEAK CHECK
38	324107	2	DECAL, CAUTION HAZARDOUS MOVING PARTS
39	324105	4	DECAL, DANGER ELECTRIC SHOCK HAZARD
40	3158201-SV	1	BACK PANEL (AIR-COOLED ONLY)

ITEM	STDELTING PN	QTY	DESCRIPTION
40A	3159551	1	BACK PANEL (WATER-COOLED ONLY)
41	598245	2	PULLEY
42	152322	2	BELT
43	598072	2	PULLEY (60 HZ ONLY)
43A	598100	2	PULLEY (50 HZ ONLY)
44	4158034	1	FRAME WELDMENT
45	324106	1	DECAL, CAUTION ELECTRIC WIRING MAT'S
46	3158266	1	LEFT CORNER MEMBER
47	628007	4	RIVET 1/8"
48	3158302	1	UPPER FRONT PANEL
49	3158268	1	RIGHT CORNER MEMBER
50	324141	1	DECAL, CAUTION HAZARDOUS BLADES
51	M820309	AS REQ'D	ALUMINUM RTV
52	464098	5	INSULATION (SIDE & FRONT PANEL)
53	M830435	AS REQ'D	ADHESIVE
54	714003	200*	CORK TAPE
55	628046	8	RIVET 1/4
56	644985	4	SCREW, 1/2-13 X 7/8" ZP
57	324686	1	DECAL, DANGER, AUTOMATIC START
58	463004	2	#10-24 THREADED INSERT
59	756079	4.0*	PLASTIC TUBING 3/8 I.D. NALGENE #380
60	324242	2	DECAL, TEMP. ADJUSTMENT
61	2170729	1	BRACKET, SUCTION LINE SUPPORT
62	628064	6	DRIVE RIVET, 1/4
63	723529	1	TAG, CAUTION GROUNDED RECEPTACLE
64	739040	1	TIE WRAP
65	1158090-SV	1	DOOR INTERLOCK ASSEMBLY
66	647651	2	SCREW, #10-24 X 1/2" TRS HD SSSL
67	766065	6	LOCKWASHER, 1/4 ZC
68	538331	6	NUT 1/4-20 ZC
69	3158043	1	REDUCER SUPPORT BRACKET (RH)
70	3158044	1	REDUCER SUPPORT BRACKET (LH)
71	767226	4	FLAT WASHER, 1/2 ZP
72	644541	6	CAPSCREW, 3/8-16 X 1 LG ZP
73	766081	6	LOCKWASHER, 3/8 ZP
74	766997	4	LOCKWASHER, 1/2 SHAKEPROOF ZP
75	324200	1	DECAL,HIGH PRESSURE CUTOUT (W/C ONLY)
76	422074	1	GRUMMET, RUBBER (W/C ONLY)
77	324065	1	DECAL WATER INLET (W/C ONLY)
78	723517	1	TAG, ATTN: WATER COOLED INSTUCTIONS

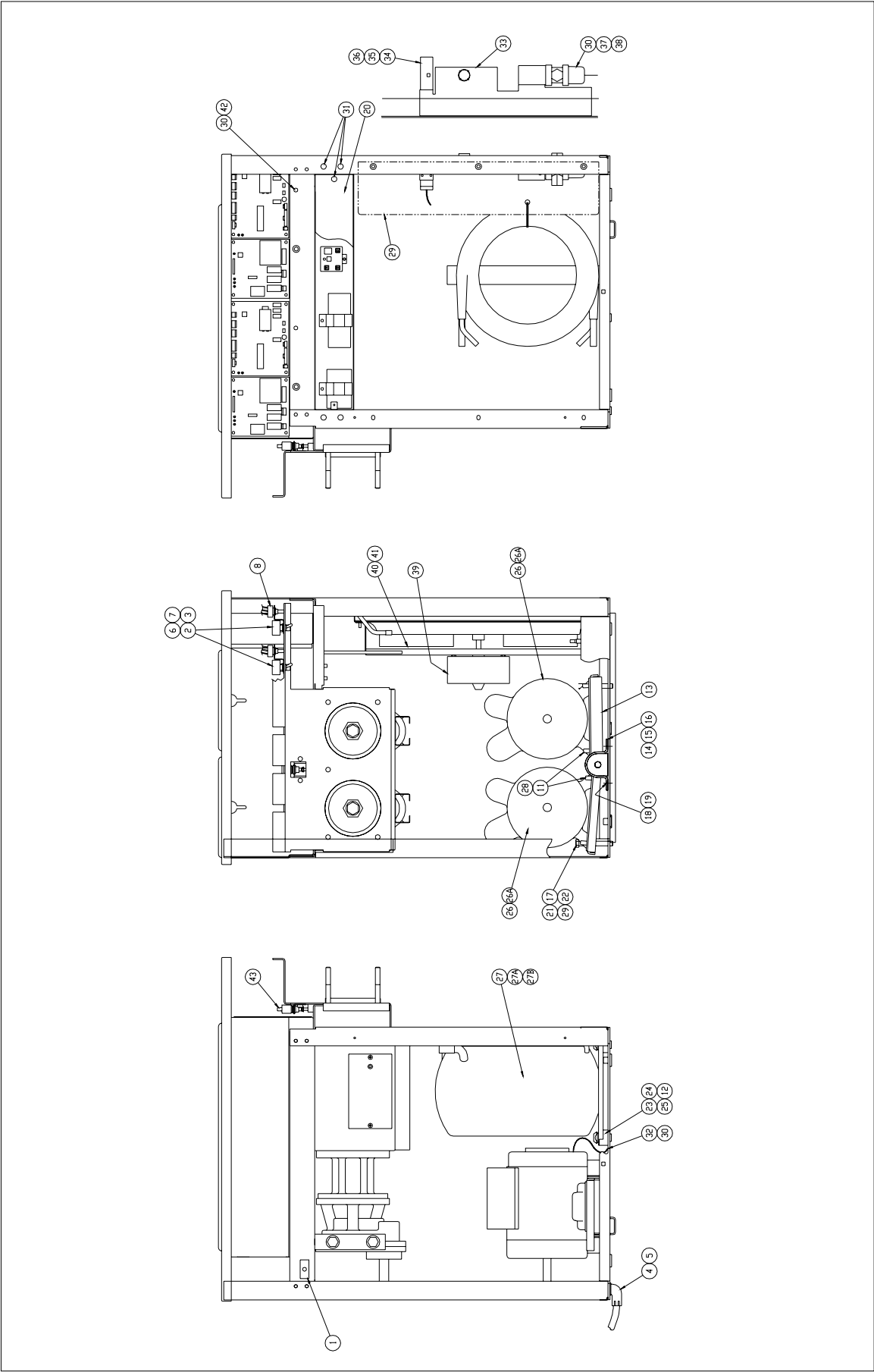

ITEM	STOELTING PN	QTY	DESCRIPTION
1	718382	1	SWITCH, PLUNGER TYPE
2	718565	2	SWITCH, TOGGLE DPST 20 AMP, 250 VAC
3	718868	2	SWITCH, LIMIT, SINGLE POLE NORMALLY
4	221545	1	BUSHING, INSUL ANTI-SHORT
5	292601	1	CONNECTOR CONDUIT 3/8 x 90°
6	227968	2	BUTTON, PUSH
7	156201	2	BEZEL
8	591009	2	POTENTIOMETER 3000 OHM
9	524091	4	MOUNT, ADHESIVE BACKED
10	739040	9	WIRE TIE, 8' LONG x 1/8" WIDE
11	644307	8	SCREW CAP 5/16-18 X 3/4 HX HD
12	766073	4	WASHER, 5/16 LOCK
13	3177426	1	MOTOR MOUNTING BASE
14	2100737	2	MOTOR MOUNTING CLAMP
15	524028	2	MOUNT, MOTOR HINGE PIN
16	221610	2	BUSHING, 3/4 x 1/2 x 1-1/4 NYLON
17	221627	2	BUSHING, MOLDED
18	766065	4	WASHER, LOCK 1/4
19	644091	4	SCREW CAP 1/4-20 X 1/2 HX HD
20	2158318	1	COVER, SIDE ELECTRICAL BOX
21	767216	2	WASHER, 3/8" FLAT
22	644610	2	SCREW CAP 3/8-16 X 2-1/4 HX ZP
23	422156	1	GROMMET KIT

ITEM	STOELTING PN	QTY	DESCRIPTION
24	644371	4	SCREW CAP 5/16-18 X 1-3/4 HX HD
25	767211	4	WASHER, FLAT, 5/16
26	522858-SV	2	MOTOR (E/F131-18, -38) 60HZ
26A	523330	2	MOTOR (E/F131-302) 50HZ
27	282045	1	COMPRESSOR (E131-18, -38) 60HZ
27B	282032	1	COMPRESSOR (F131-18, -38, -302) 50/60HZ
28	538351	8	NUT, 5/16-18 SPINLOCK ZP
29	2159531	1	WIRE GUARD (WATER-COOLED ONLY)
30	766940	2	WASHER, SHAKEPROOF #8
31	647653	6	SCREW #10-24 x 3/8 TRS HD
32	649104	3	SCREW TAP 10-24 X 3/8 RD HD PH
33	3159550	1	WATER VALVE BRACKET
34	718702	1	SWITCH, PRESSURE (W/C ONLY)
35	766933	2	WASHER, SHAKEPROOF #6
36	647393	2	SCREW, #6-32 x 3/8 ZC
37	763181	1	WATER VALVE 3/8 NPT
38	644024	2	SCREW, #8-32 x 1/4 HX HD
39	522291	1	MOTOR, FAN
40	3156518	1	FAN BRACKET
41	162077	1	BLADE FAN 16 IN
42	649103	1	SCREW T/C 10-24 X 3/8 HWH SL
43	1158090-SV	1	DOOR INTERLOCK SWITCH

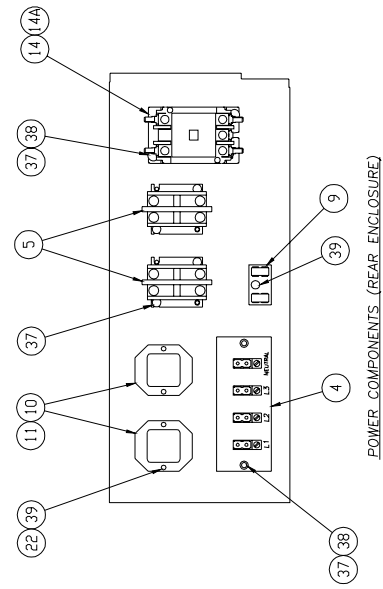

POWER COMPONENTS (REAR ENCLOSURE)

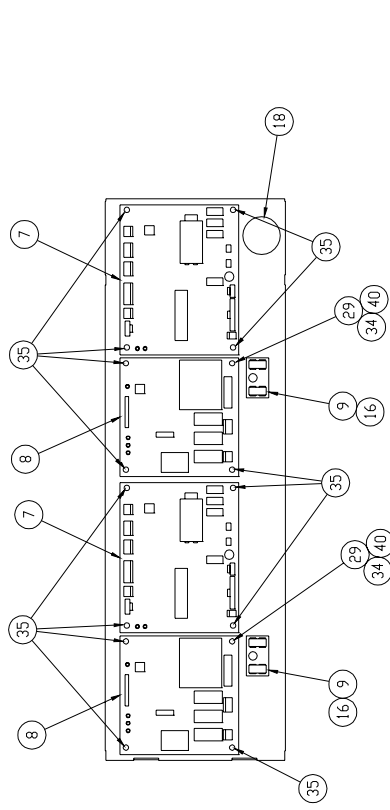

CONTROL COMPONENTS (SIDE ENCLOSURE)

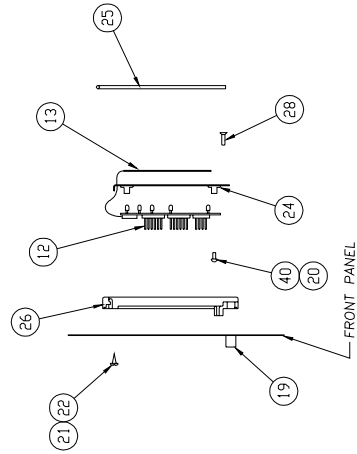

MEMBRANE SWITCH & HOUSING

CAPACITOR BOX COMPONENTS

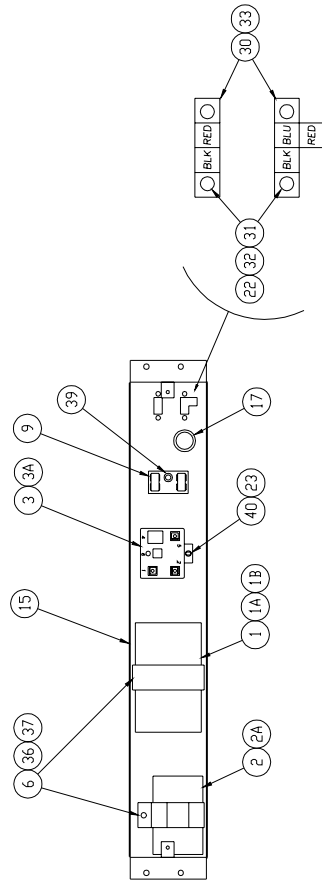

ITEM	STOELTING PN	QTY	DESCRIPTION
1	230632	1	CAPACITOR START (E131-18, -38) 60HZ
2	230633	1	CAPACITOR RUN (E131-18, -38, -302)
3	618142	1	RELAY START (E/F131-18,-302, E131-38)
3A	618156	1	RELAY START (F131-38)
4	732016	1	TERMINAL BOARD
5	295017	2	CONTACTOR MAGNET 20A 2POLE
6	2156689	2	CAPACITOR BRACKET (2.0 DIA)
7	521660	2	MODULE, CONTROL PROGRAM BOARD
8	521546	2	MODULE, POWER SUPPLY, 230V
9	732010	4	TERMINAL BLOCK
10	618160	2	RELAY DPDT 8 PIN 240VAC COIL
11	688058	2	SOCKET RELAY 8 PIN DCTAL
12	521547	2	MODULE, MEMBRANE SWITCH
13	718866-SV	2	SWITCH, MEMBRANE STRIP
14	295005	1	CONTACTOR (42AF15AG)
14A	295005-SV	1	CONTACTOR (41NB20AGP)
15	3158039	1	CAPACITOR BOX
16	649080	2	SCREW TAP 8-32 X 1/2 LG PAN HD
17	223058	1	BUSHING SNAP 11/16 ID HOLE 7/8
18	223016	1	BUSHING SNAP 1.50 MTG HOLE

ITEM	STOELTING PN	QTY	DESCRIPTION
19	463012	2	INSERT RECEPTACLE 1/4 TURN
20	647393	8	SCREW MACH 6-32 X 3/8 RD HD PI
21	649076	8	SCREW TAP 8-32 X 3/8 PAN HD PI
22	766940	16	WASHER SHAKEPROOF 8 ZINC PLATE
23	647376	1	SCREW MACH 6-32 X 1/4 RD HD PI
24	2158189	2	SWITCH MOUNTING PLATE
25	521216	2	COVER MEMBRANE SWITCH HOUSING
26	521215	2	HOUSING, MEMBRANE SWITCH BLACK
27	714003	9.0'	STRIP 3/8 WIDE CORK/RUBBER
28	647412	2	SCREW MACH 6-32 X 3/8' LG
29	692206	4	SPACER, ALUMINUM
30	732118	4	TERMINAL PANEL MOUNT (RED)
31	647560	4	SCREW MACH 8-32 X 1 RD HD PH
32	538280	4	NUT HEX 8-32X11/32X1/8 STL
33	M820077	AS REQ	ADHESIVE LOCTITE-495
34	649063	2	SCREW TAP #6 X 1' PH PAN HD
35	524087	14	MOUNT DUAL LOCK CIRCUIT SPACER
36	538297	2	NUT HEX FULL 10-24 ZP
37	766948	10	WASHER SHAKEPROOF 10 ZINC
38	647668	8	SCREW MACH 10-24 X 1/2 RD HD
39	647529	6	SCREW MACH 8-32 X 1/2 RD HD PI
40	766933	11	WASHER SHAKEPROOF 6X5/16

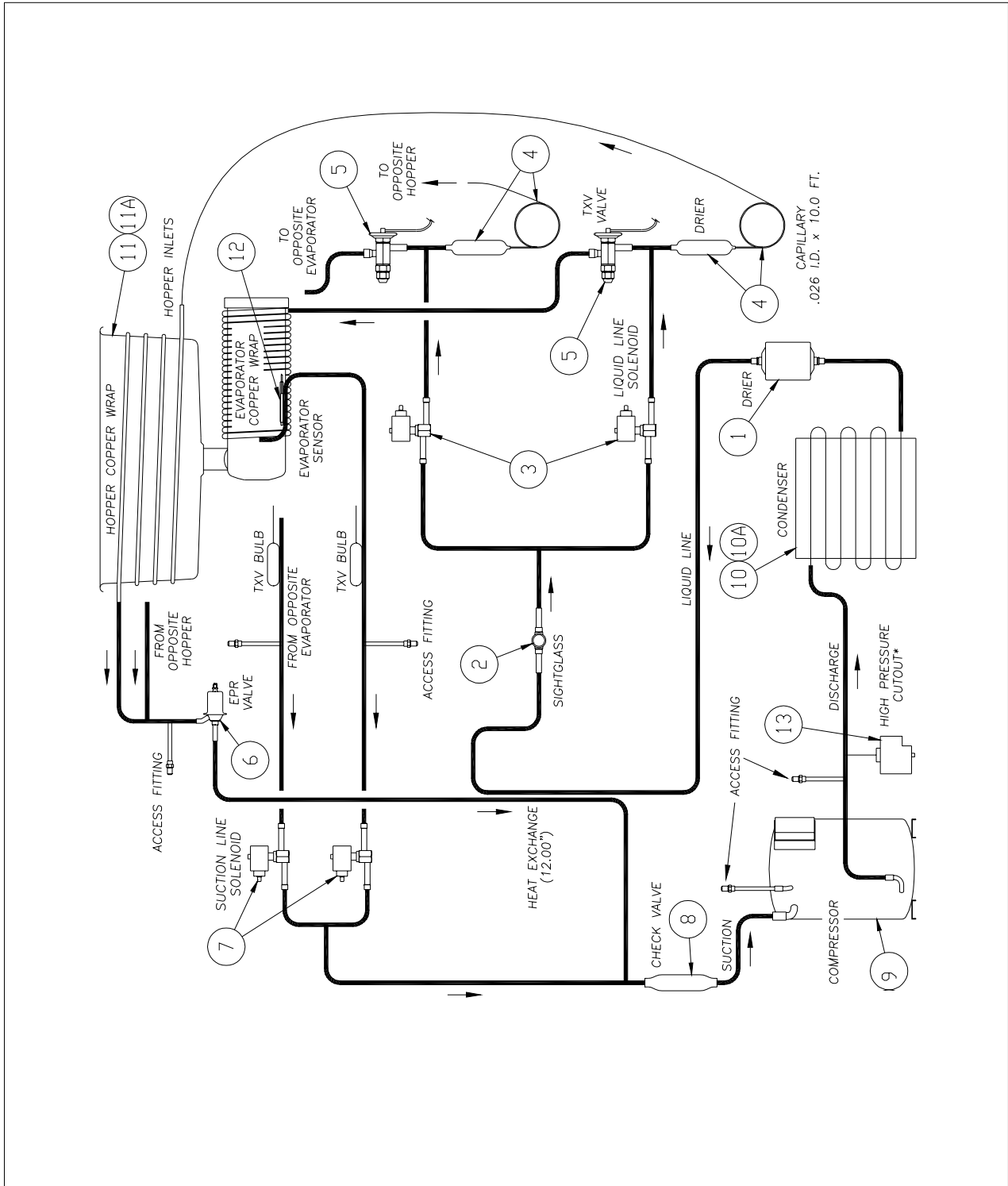

ITEM	PART NUMBER	QTY	DESCRIPTION
1	342004	1	DRIER, FILTER
2	458003	1	INDICATOR, SIGHT GLASS 1/4
3	763422	1	VALVE, SOLENOID 1/4 X 1/4
4	231105-SV	1	CAP TUBE AND DRIER KIT
5	762454	1	VALVE, EXPANSION 1/4 TON
6	762978	1	VALVE, EPR
7	763423	1	VALVE, SOLENOID 1/2 X 1/2
8	762275	1	VALVE, CHECK (MAGNI-CHECK)
9	282045	1	COMPRESSOR (E131-18G/E131-38G) 60HZ
9A	282032	1	COMPRESSOR (F131-18G/F131-38G) 60HZ
10	284104	1	CONDENSER (WATER-COOLED)
10A	284071	1	CONDENSER (AIR-COOLED)
11	4177924-SV	1	HOPPER/EVAPORATOR ASSY (E131G ONLY)
11A	4177944-SV	1	HOPPER/EVAPORATOR ASSY (F131G ONLY)
12	2171962	1	SENSOR KIT
13	718702	1	SWITCH, HI PRESSURE MANUAL RESET

