



**Model E112-LJ / F112-LJ**  
**SERVICE MANUAL**

Manual No. [513656](#)

Mar. 2010



This manual provides basic information about the machine. Instructions and suggestions are given covering its operation and care.

The illustrations and specifications are not binding in detail. We reserve the right to make changes to the machine without notice, and without incurring any obligation to modify or provide new parts for machines built prior to date of change.

**DO NOT ATTEMPT** to operate the machine until instructions and safety precautions in this manual are read completely and are thoroughly understood. If problems develop or questions arise in connection with installation, operation, or servicing of the machine, contact Stoelting.



[stoeltingfoodservice.com](http://stoeltingfoodservice.com)

Stoelting Foodservice Equipment  
502 Highway 67  
Kiel, WI 53042-1600  
U.S.A.

Main Tel: 800.558.5807  
Fax: 920.894.7029

Customer Service: 888.429.5920  
Fax: 800.545.0662  
Email: [foodservice@stoelting.com](mailto:foodservice@stoelting.com)

© 2014 PW Stoelting, LLC

---

## ***A Few Words About Safety***

### **Safety Information**

**Read and understand the entire manual before operating or maintaining Stoelting equipment.**

This manual provides the operator with information for the safe operation and maintenance of Stoelting equipment. As with any machine, there are hazards associated with their operation. For this reason safety is emphasized throughout the manual. To highlight specific safety information, the following safety definitions are provided to assist the reader.

The purpose of safety symbols is to attract your attention to possible dangers. The safety symbols, and their explanations, deserve your careful attention and understanding. The safety warnings do not by themselves eliminate any danger. The instructions or warnings they give are not substitutes for proper accident prevention measures.

If you need to replace a part, use genuine Stoelting parts with the correct part number or an equivalent part. We strongly recommend that you do not use replacement parts of inferior quality.



### **Safety Alert Symbol:**

**This symbol** Indicates danger, warning or caution. Attention is required in order to avoid serious personal injury. The message that follows the symbol contains important information about safety.

### **Signal Word:**

Signal words are distinctive words used throughout this manual that alert the reader to the existence and relative degree of a hazard.



The signal word “WARNING” indicates a potentially hazardous situation, which, if not avoided, may result in death or serious injury and equipment/property damage.



The signal word “CAUTION” indicates a potentially hazardous situation, which, if not avoided, may result in minor or moderate injury and equipment/property damage.

### **CAUTION**

The signal word “CAUTION” not preceded by the safety alert symbol indicates a potentially hazardous situation, which, if not avoided, may result in equipment/property damage.

### **NOTE (or NOTICE)**

The signal word “NOTICE” indicates information or procedures that relate directly or indirectly to the safety of personnel or equipment/property.

# TABLE OF CONTENTS

<b>Section</b>	<b>Description</b>	<b>Page</b>
<b>1</b>	<b>Description and Specifications</b>	
1.1	Description .....	1
1.2	Specifications .....	2
1.3	Modes of Normal Operation .....	4
1.4	Operation During an Error Mode .....	5
<b>2</b>	<b>Installation Instructions</b>	
2.1	Safety Precautions .....	7
2.2	Shipment and Transit .....	7
2.3	Machine Installation .....	7
2.4	Auto Fill Pump Installation .....	8
<b>3</b>	<b>Initial Set-Up and Operation</b>	
3.1	Operator's Safety Precautions .....	9
3.2	Operating Controls and Indicators .....	9
3.3	Removing Mix From Machine .....	10
3.4	Disassembly of Machine Parts .....	10
3.5	Cleaning and Sanitizing the Machine Parts .....	11
3.6	Assembly of Machine .....	12
3.7	Sanitizing .....	13
3.8	Freeze Down and Operation .....	13
3.9	Mix Information .....	14
3.10	Routine Cleaning .....	14
3.11	Preventative Maintenance .....	14
3.12	Extended Storage .....	16
<b>4</b>	<b>Maintenance and Adjustments</b>	
4.1	Machine Adjustment .....	17
4.2	Product Consistency Adjustment .....	17
4.3	Drive Belt Tension Adjustment .....	17
4.4	Auto Fill Pump Maintenance .....	17

<b>Section</b>	<b>Description</b>	<b>Page</b>
<b>5</b>	<b>Refrigeration System</b>	
5.1	Refrigeration System.....	19
5.2	Refrigerant Recovery and Evacuation.....	19
5.3	Refrigerant Charging.....	20
5.4	Compressor.....	20
5.5	Condenser.....	22
5.6	Valves.....	22
A.	Thermostatic Expansion Valve (TXV).....	22
B.	High Pressure Cutout.....	23
C.	Evaporator Pressure Regulaotr (EPR).....	24
D.	Water Valve (Water Cooled Models Only).....	24
5.7	Capillary Tube.....	25
5.8	Filter Drier.....	26
<b>6</b>	<b>Electrical and Mechanical Control Systems</b>	
6.1	Control Board.....	27
6.2	Contactactor.....	27
6.3	Drive Motor.....	28
6.4	Capacitors.....	29
6.5	Gearbox.....	30
6.6	Condenser Fan Motor (AirCooled Models Only).....	30
6.7	Switches.....	31
A.	Spigot Switch.....	31
B.	Torque Switch.....	31
<b>7</b>	<b>Troubleshooting</b>	
7.1	Light Indicators.....	33
7.2	Troubleshooting - Machine.....	33
7.3	Troubleshooting - AutoFill System.....	34
<b>8</b>	<b>Replacement Parts</b>	
8.1	Decals, Lubrication, Panels & Legs.....	35
8.2	Auger Shaft and Faceplate Parts.....	36
8.3	Hopper Parts.....	38
8.4	Machine Front & Spigot Switch Assembly.....	39
8.5	E112-LJ Parts.....	40
8.6	F112-LJ Parts.....	42
8.7	Auto Fill Parts.....	44
8.8	Refrigeration Diagram.....	45
8.9	E112-LJ Wiring Diagram.....	46
8.10	F112-LJ Wiring Diagram.....	47

# SECTION 1 DESCRIPTION AND SPECIFICATIONS

## 1.1 DESCRIPTION

The Stoelting E112-LJ /F112-LJ counter machines are gravity fed. The machines are equipped with fully automatic controls to provide a uniform product. This manual is designed to help qualified service personnel and operators with the installation, operation and maintenance of the Stoelting E112-LJ /F112-LJ gravity machines.



Figure 1-1 Model E112-LJ



Figure 1-1 Model F112-LJ



1.2 SPECIFICATIONS - CONTINUED

	Model E112		Model F112	
<b>Dimensions</b>	<b>Machine</b>	<b>with crate</b>	<b>Machine</b>	<b>with crate</b>
width	15-1/4" (38,7 cm)	17-1/2" (44,5 cm)	17-1/4" (43,8 cm)	29" (73,7 cm)
height	30-1/2" (77,5 cm)	35" (88,9 cm)	33" (83,8 cm)	44" (111,8 cm)
depth	32" (81,3 cm)	36-1/2" (92,7 cm)	30-1/4" (76,8 cm)	39" (99,1 cm)
<b>Weight</b>	205 lbs (92,9 kg)	215 lbs (97,5 kg)	288 lbs (130,6 kg)	315 lbs (142,8 kg)
<b>Electrical</b>	<b>1 Phase, 115 VAC, 60Hz</b>		<b>1 Phase, 208-240 VAC, 60Hz</b>	
running amps	approximately 16A		approximately 10A	
connection type	NEMA5-20P power cord provided		NEMA6-15P power cord provided	
International Option	1 Phase, 220-240 VAC, 50Hz		1 Phase, 220-240 VAC, 50Hz	
<b>Compressor</b>	6,000 Btu/hr		8,600 Btu/hr	
<b>Drive Motor</b>	1/3 hp		3/4 hp	
<b>Air Flow</b>	Air cooled units require 3" (7,6 cm) air space on both sides or 4" (10,2 cm) air space in back for side-by-side installation		Air cooled units require 6" (15,24 cm) air space on both sides	
<b>Plumbing Fittings</b>	N/A		Water cooled units require 3/8" N.P.T. water and drain fittings.	
<b>Hopper Volume</b>	3.625 gallon (13,73 liters)		5.375 gallon (20,35 liters)	
<b>Freezing Cylinder Volume</b>	1.25 gallon (5 quart), 4,73 liters		2.125 gallon (8.5 quart), 8,04 liters	
<b>Production Capacity</b>	18 GPH (68,15 liters)		24 GPH (90,87 liters)	

	E112-LJ
<b>Refrigerant</b>	R-404A
<b>Charge</b>	20 oz
<b>Suction Pressure (at 72°F)</b>	30-32 psig
<b>Discharge Pressure</b>	200-205 psig
<b>EPR Valve</b>	59-61 psig

	F112-LJ
<b>Refrigerant</b>	R-404A
<b>Charge</b>	(W/C) 20 oz (A/C) 28 oz
<b>Suction Pressure (at 85°F)</b>	40 psig
<b>Discharge Pressure</b>	280 psig
<b>EPR Valve</b>	59-61 psig

### 1.3 MODES OF NORMAL OPERATION

Following is an explanation of the normal operation modes on the E112-LJ and F112-LJ (Refer to Figure 1-3).

#### NOTE

*Slush mode has two options: normal and continuous drive. With the continuous drive option selected, the drive motor will run at all times, including standby. To change the control between the two options, refer to Section 4.3.*

#### A. PRE STIR

When the CLEAN-OFF-ON is moved into the ON position or when the spigot is opened, the drive motor will start a 4-second pre stir. A consistency check will determine if a freezing cycle will begin.

#### B. FREEZING CYCLE

After the pre stir, a freezing cycle begins. The freezing cycle continues until the torque rod closes the torque switch and keeps the switch closed for 3 seconds. If product consistency is not met within 22 minutes, the machine will operate in the compressor time out mode (See Section 1.4).

#### NOTE

*If the spigot is pulled during a freezing cycle, the 22-minute timer will restart.*

#### C. POST STIR

After the freezing cycle ends, the drive motor will continue to run for an 18 second post stir. The post stir ensures the product does not freeze to the cylinder. If the spigot is opened during the post stir, the machine will check consistency. If the product is at consistency, the machine will move into standby. If the product is not at consistency, the machine will start a freezing cycle.

#### D. STANDBY

After the post stir, the machine will be in standby. It will remain in standby for 7 minutes or until the spigot is opened.

#### E. DEFROST MODE

If the spigot is not opened for 3 hours, defrost mode will begin. The drive motor will run for 90 seconds every 7 minutes and the diagnostic light will remain lit.

After 8 hours or if the spigot is opened, normal operation mode will begin.

#### F. CLEAN MODE

When the CLEAN-OFF-ON switch is in the CLEAN position, the drive motor starts and will run for 20 minutes. After the 20 minutes expire, the drive motor will stop and the diagnostic light will flash three times every 4 seconds. It will continue to flash until the CLEAN-OFF-ON switch is moved out of the CLEAN position.

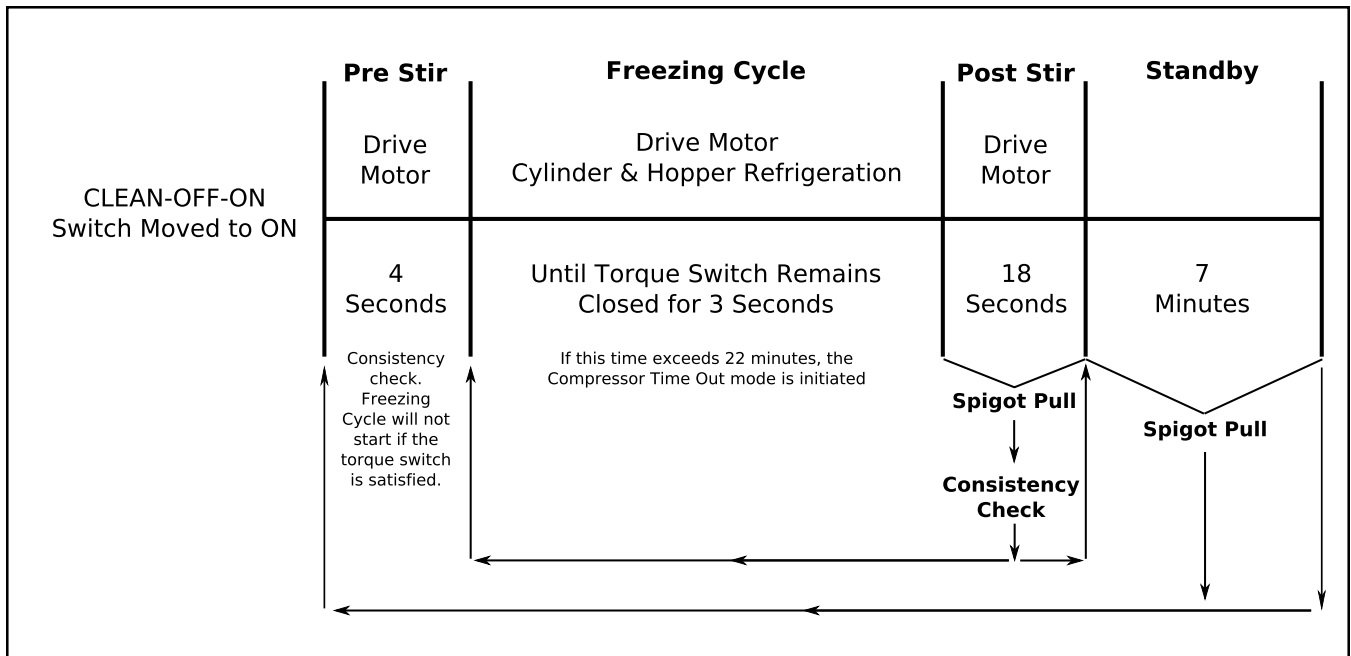


Figure 1-3 Modes of Normal Operation

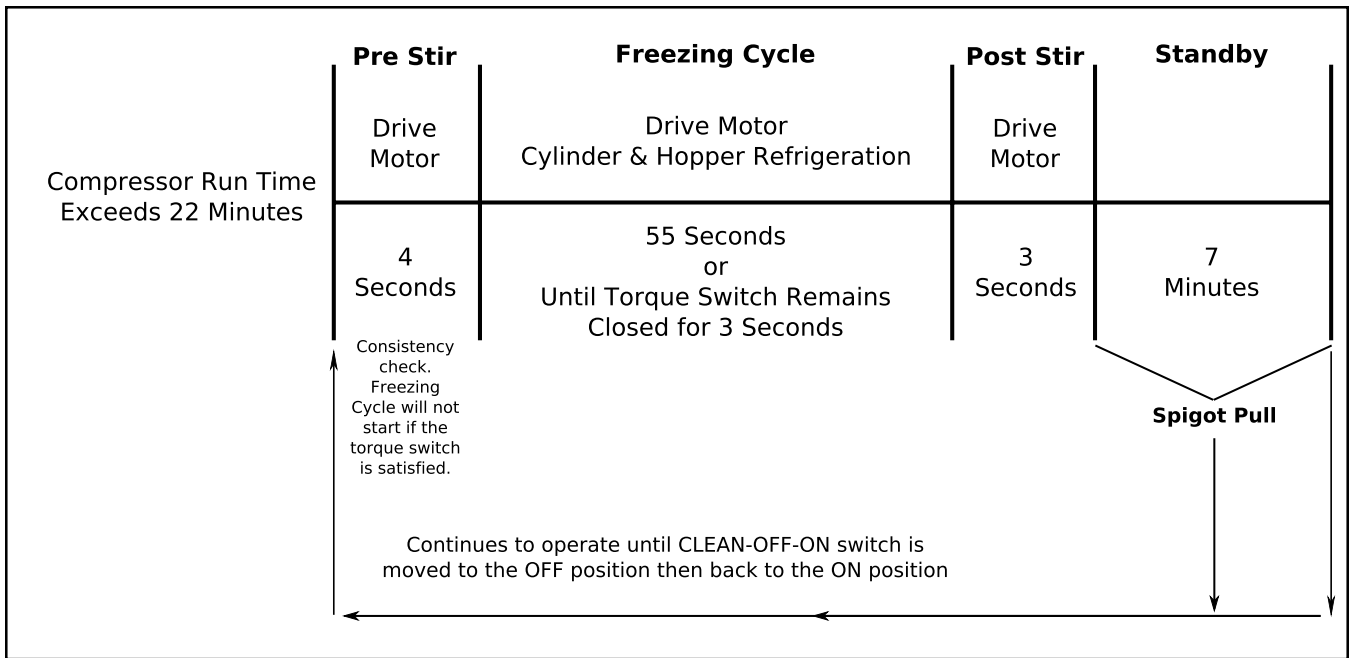


Figure 1-4 Compressor Time Out Mode

**1.4 OPERATION DURING AN ERROR MODE**

**A. COMPRESSOR TIME OUT MODE**

If the freezing cycle exceeds 22 minutes, the machine will operate on timers. The diagnostic light will flash once every 4 seconds (Refer to Figure 1-4).

pump off and the ADD MIX light will continuously flash. The machine will continue to operate on timers until the empty BIB is replaced and the mix in the hopper is above the sensor probe (Refer to Figure 1-5).

**B. LOW MIX MODE**

If the mix level falls below the sensor probe, the auto fill system will attempt to fill the hopper. The ADD MIX light will flash for a couple of seconds while the solenoid opens and fills the hopper. If the bag in box (BIB) is empty, the vacuum shutoff on the auto fill pump will automatically shut the

**NOTE**

After the BIB is replaced the vacuum shutoff on the auto fill pump will automatically reset. The solenoid may have a max runtime error. Turn the Clean/Off/On switch Off and back On.

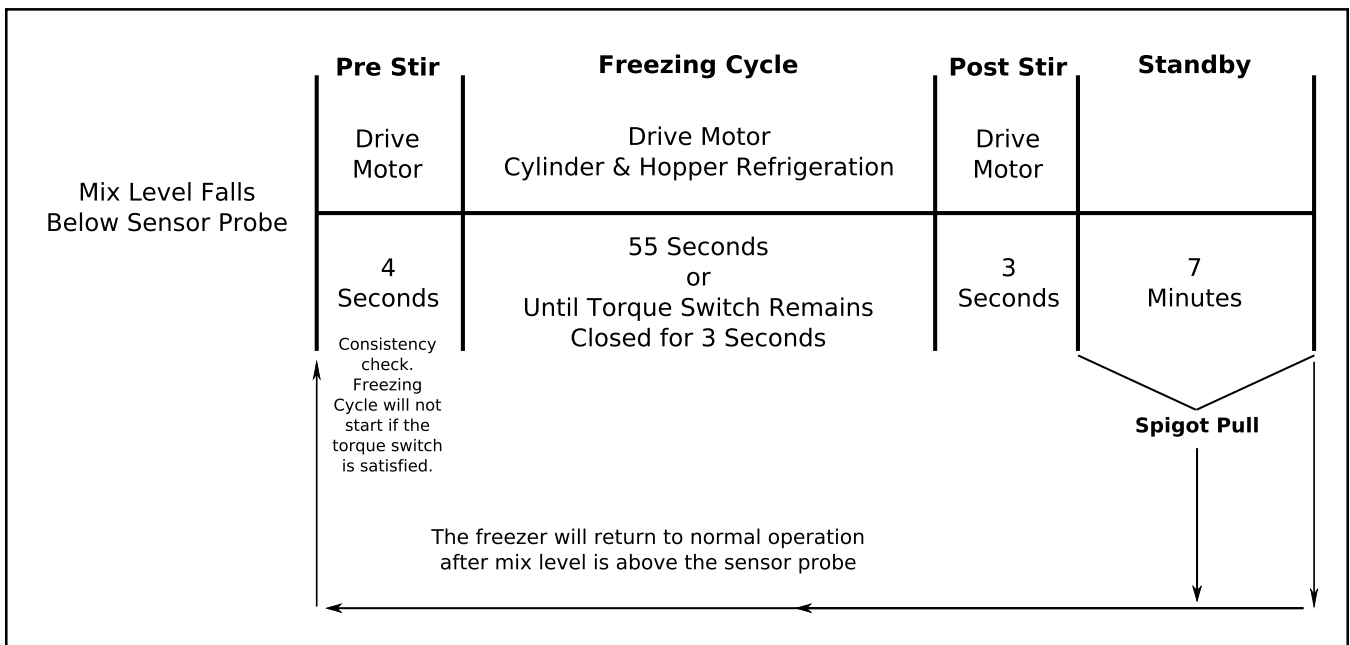
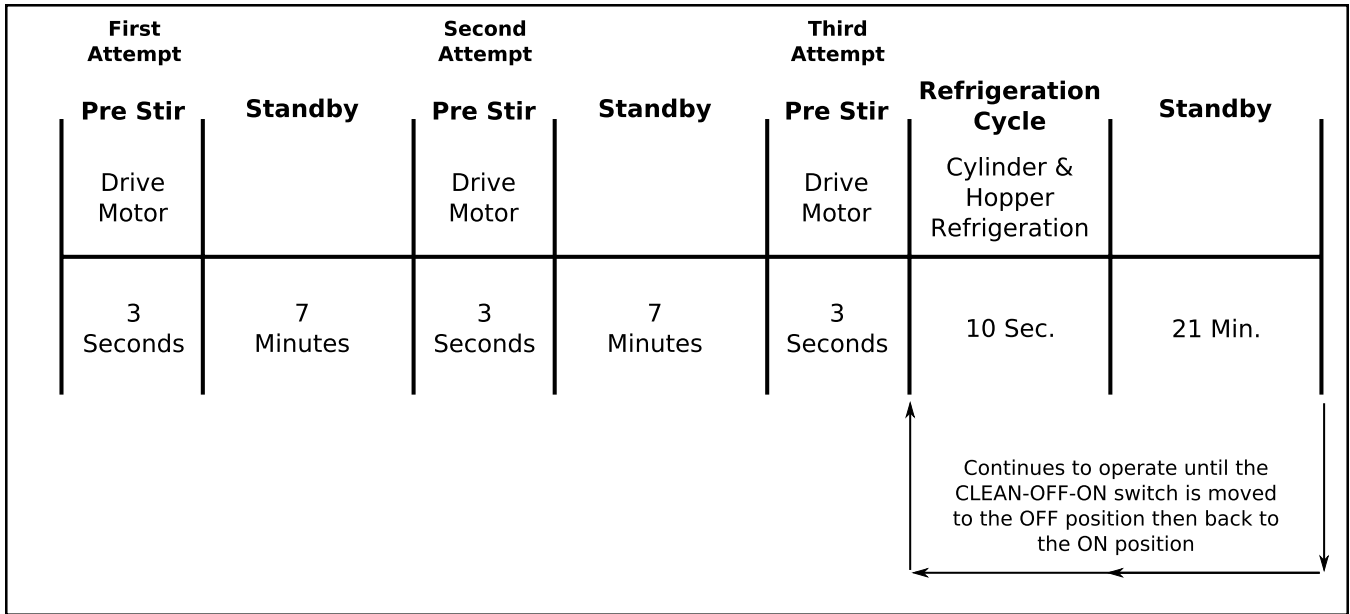


Figure 1-5 Low Mix Mode



**Figure 1-6 Drive Motor Error Mode**

**C. DRIVE MOTOR ERROR MODE**

If the control does not sense current from the drive motor during a pre stir, the machine will go into standby mode for 7 minutes. After standby, the control will repeat the pre stir and attempt to sense drive motor current. After the third pre stir without sensing drive motor current, the machine will operate on timers and the diagnostic light will flash twice every four seconds (Refer to Figure 1-6). The attempts to sense the drive motor current can be substituted by pulling the spigot.

## SECTION 2 INSTALLATION INSTRUCTIONS

### 2.1 SAFETY PRECAUTIONS

Do not attempt to operate the machine until the safety precautions and operating instructions in this manual are read completely and are thoroughly understood.

Take notice of all warning labels on the machine. The labels have been put there to help maintain a safe working environment. The labels have been designed to withstand washing and cleaning. All labels must remain legible for the life of the machine. Labels should be checked periodically to be sure they can be recognized as warning labels.

If danger, warning or caution labels are needed, indicate E. the part number, type of label, location of label, and quantity required along with your address and mail to:

**STOELTING**  
**ATTENTION: Customer Service**  
**502 Hwy. 67**  
**Kiel, Wisconsin 53042**

### 2.2 SHIPMENT AND TRANSIT

The machine has been assembled, operated and inspected at the factory. Upon arrival at the final destination, the entire machine must be checked for any damage which may have occurred during transit.

With the method of packaging used, the machine should arrive in excellent condition. **THE CARRIER IS RESPONSIBLE FOR ALL DAMAGE IN TRANSIT, WHETHER VISIBLE OR CONCEALED.** Do not pay the freight bill until the machine has been checked for damage. Have the carrier note any visible damage on the freight bill. If concealed damage and/or shortage is found later, advise the carrier within 10 days and request inspection. The customer must place claim for damages and/or shortages in shipment with the carrier. Stoelting cannot make any claims against the carrier.

### 2.3 MACHINE INSTALLATION

Installation of the machine involves moving the machine close to its permanent location, removing all crating, setting in place, assembling parts, and cleaning.

- A. Uncrate the machine.
- B. Determine the location of the machine. The location must be able to hold 350 lbs.
- C. Accurate leveling is necessary for correct drainage of machine barrel and to insure correct overrun. Place a bubble level on top of the machine at each corner to check for level condition. If adjustment is necessary, level the machine by turning the bottom part of each leg in or out.
- D. The F112-LJ has a base gasket that must be installed. Separate the gasket and install it with the seam to the back. Make sure the angled side of the gasket is facing up.



**Figure 2-2 Space and Ventilation Requirements**

Correct ventilation is required. The E112-LJ requires 3" clearance on both sides. If the machine is placed side-by-side next to other equipment, there needs to be at least 4" clearance at the back of the machine. The air-cooled F112-LJ requires 6" clearance on both sides for proper air flow.

#### CAUTION

Failure to provide adequate ventilation will void warranty.

- F. Connect the drip tray bracket by loosening the two screws at the front of the machine. Install the bracket so that it rests on the nylon washer between the two metal washers. Tighten the screws.



**Figure 2-3 Drip Tray Bracket**

- G. Place the CLEAN-ON-OFF switch in the OFF position.



**WARNING**

Do not alter or deform electrical plug in any way .  
Altering the plug to fit into an outlet of different configuration may cause fire, risk of electrical shock, product damage and will void warranty

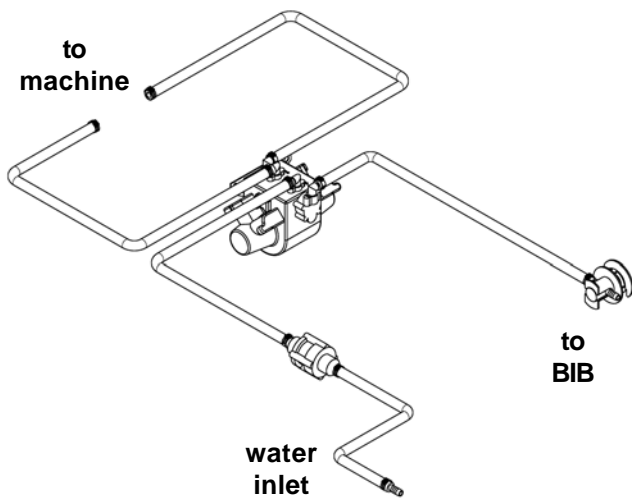
- H. Connect the power cord to the proper power supply. The plug on the E112 is designed for 115VAC / 20 amp duty and the plug on the F112 is designed for 208-240VAC / 15 amp duty. Check the nameplate on your machine for proper supply. The unit must be connected to a properly grounded receptacle. The electrical cord furnished as part of the machine has a three prong grounding type plug. The use of an extension cord is not recommended, if necessary use one with a size 12 gauge or heavier with ground wire. Do not use an adapter to get around grounding requirement.

**2.4 AUTO FILL PUMP INSTALLATION**

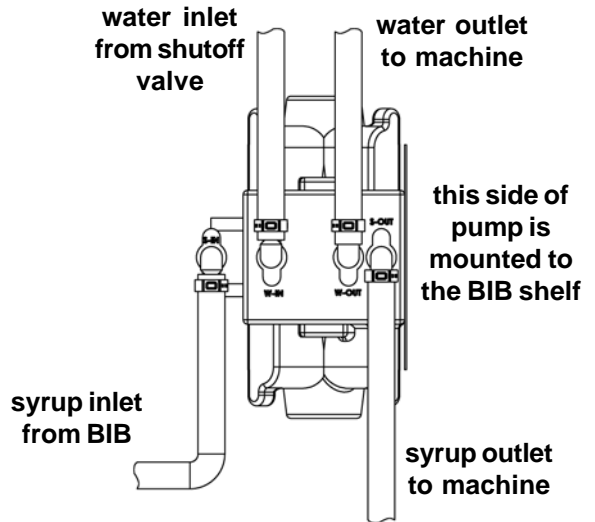
The auto fill pump is powered by water and has a fixed orifice that delivers water and syrup to the machine at an exact ratio. The auto fill kit is designed for use with Bag In Box (BIB) concentrated syrup.

Follow these instructions to properly install the brix pump

- A. Route the clear tubing with the BIB connector to the BIB. If there is excess tubing, trim it and reconnect it to the BIB connector.
- B. Route the water line tubing to the shutoff valve of the water supply. Trim excess tubing and connect it to the shutoff valve.
- C. Route the water line and syrup line tubing (3/8" braided tubing) from the pump to the machine.

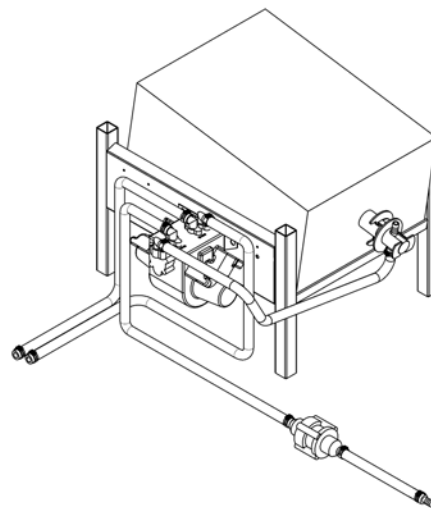


**Figure 2-4 Auto Fill Pump Tubing Layout**



**Figure 2-5 Top View of Pump**

- D. Route the water line tubing to the tube exiting the rear panel. Trim excess tubing and connect.
- E. Route the syrup line to the tubing connected to the adapter on the hopper cover. Trim excess tubing and connect.
- F. Check that the clear tubing coming out of the rear panel is connected to the plug in the hopper cover. If not, connect it using a clamp in the kit.
- G. Check that all tubing connections are properly clamped, fittings are tightened and the tubing is not kinked.



**Figure 2-6 Auto Fill Pump Kit**

## SECTION 3 INITIAL SET-UP AND OPERATION

### 3.1 OPERATOR'S SAFETY PRECAUTIONS

SAFE OPERATION IS NO ACCIDENT; observe these rules:

- A. Know the machine. Read and understand the Operating Instructions.
- B. Notice all warning labels on the machine.
- C. Wear proper clothing. Avoid loose fitting garments, and remove watches, rings or jewelry that could cause a serious accident.
- D. Maintain a clean work area. Avoid accidents by cleaning up the area and keeping it clean.
- E. Stay alert at all times. Know which switch, push button or control you are about to use and what effect it is going to have.
- F. Disconnect electrical cord for maintenance. Never attempt to repair or perform maintenance on the machine until the main electrical power has been disconnected.
- G. Do not operate under unsafe operating conditions. Never operate the machine if unusual or excessive noise or vibration occurs.

### 3.2 OPERATING CONTROLS AND INDICATORS

Before operating the machine, it is required that the operator know the function of each operating control. Refer



#### WARNING

High voltage will shock, burn or cause death. The OFF-ON switch must be placed in the OFF position prior to disassembling for cleaning or servicing. Do not operate machine with cabinet panels removed.

to Figure 3-1 for the location of the operating controls on the machine.

#### A. Spigot Switch

The spigot switch will automatically start the auger drive and refrigeration systems when the spigot is opened to dispense product. When the spigot is closed, the drive motor and compressor will remain on until the product in the freezing cylinder reaches the proper consistency..



Figure 3-1 Controls

**B. CLEAN-OFF-ON Switch**

The CLEAN-OFF-ON switch is used to supply power to the control circuit. When the switch is in the OFF (middle) position, power will not be supplied to the control board or refrigeration system. When the switch is in the ON position, the machine will operate in the freezing mode. When the switch is in the CLEAN position, all refrigeration will stop and the auger will start rotating.

**C. ADD MIX Light**

The ADD MIX light will flash to alert the operator to a low mix condition. It does so by monitoring the mix level in the hopper. If the ADD MIX light is flashing, check the auto fill system to determine the issue. Refer to the troubleshooting section for details

**D. Diagnostic Light**

The Diagnostic Light will remain lit for defrost mode. It will flash if an error occurs. The light will flash once if there is a compressor error. There will be two quick flashes if there is an auger error. And there will be three quick flashes if the machine is left in clean mode for more than 20 minutes. Refer to the troubleshooting section for details.

**E. Consistency Adjustment Screw**

The Consistency Adjustment Screw increases or decreases product consistency. A tension spring is connected to the screw and changes the amount of torque needed to complete a refrigeration cycle. Turn the knob clockwise to increase consistency or counterclockwise to decrease consistency.

**F. Front Door Safety Switch**

The front door safety switch prevents the auger from turning when the front door is removed. The switch is open when the door is not in place and closed when the door is properly installed.

**G. Hopper Probes**

The mix level in the hopper is controlled by two probes. When mix in the hopper gets below the long probe, the solenoid opens and the hopper fills. When the mix level reaches the short probe, the solenoid closes.

**3.3 REMOVING MIX FROM MACHINE**

To remove the mix from the machine, refer to the following steps:

- A. Wash, rinse, dry and sanitize hands before starting.
- B. Turn the water line lever to the Off position.
- C. Place the Clean/Off/On switch to Clean and drain the mix from the freezer into a utility bucket and turn off the machine. Discard mix into the second compartment of a 3-compartment sink.
- D. Fill the hopper with 2 gallons of clean, cold water using the clean white utility bucket.
- E. Place the Clean/Off/On switch to Clean. Run the machine in Clean mode for approximately 5 minutes. Continue to the next step while the machine is cleaning.
- F. Prepare Stera-Sheen Green Label Sanitizer according to manufacturer's instructions to provide a 100ppm strength solution. In the blue cleaner/sanitizer bucket, mix 1 packet of sanitizer and 2 gallons of cold water. Check the chlorine content with a test strip to ensure 100ppm strength. After 5 minutes, drain the water from the machine into the red utility bucket and discard the water.

**NOTE**


*If the water does not drain clear, repeat the steps.*

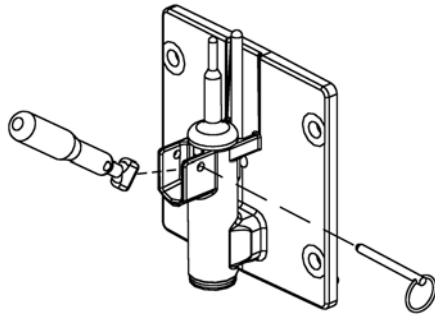
- H. Place the Clean/Off/On switch Off.
- I. Fill the hopper with the 2 gallons of sanitizer solution from the blue bucket.
- J. Place the Clean/Off/On switch to Clean. Run the machine in Clean mode for approximately 5 minutes.
- K. After 5 minutes, drain the sanitizer solution from the machine into the red utility bucket and discard the solution.

**3.4 DISASSEMBLY OF MACHINE PARTS**

Inspect for worn or broken parts each time the machine is disassembled. Replace any worn or broken parts to ensure safety to both the operator and the customer and to maintain good machine performance and a quality product. Frequency of cleaning must comply with the local health regulations.

To disassemble the machine, refer to the following steps:

 <b>CAUTION</b>
<b>Hazardous Moving Parts.</b> Revolving auger shaft can grab and cause injury . Place the switch in the OFF (middle) position before disassembling for cleaning or servicing.



**Figure 3-2 Remove Spigot Pin**

- A. Pull out the spigot pin by its ring. Remove the spigot handle.

**NOTE**

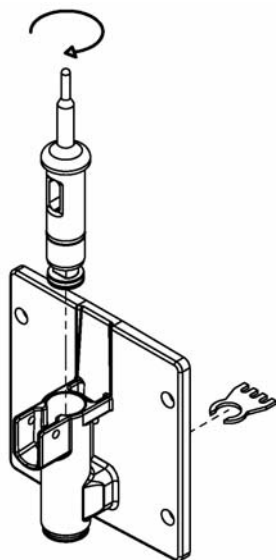
*Place all parts into the lemonade parts basket immediately after removing from the machine. Place small parts onto the small parts rod in the basket.*

- B. Remove front door by turning the circular knobs and then pulling door off the studs.

**NOTE**

*When removing front door, entire door and stator assembly will come out as well.*

- C. Remove the torque rod from the stator assembly.
- D. Remove the quad ring from the groove in front door.
- E. Remove the stator bar. Remove the small white bushing.



**Figure 3-3 Spigot and Ice Breaker Bar Removal**



**Figure 3-4 Removing O-Ring**

- F. Remove the o-rings at the front and back of the stator bar by first wiping off the lubricant using a clean paper towel. Then squeeze the o-ring upward with a dry cloth. When a loop is formed, roll the o-ring out of the groove.
- G. Remove the auger support bushing.
- H. Turn the spigot body until the ice breaker bar can be removed. Remove breaker bar.
- I. Remove the spigot body from the front door.
- J. Remove the o-rings (2) from the spigot.
- K. Remove the auger assembly from the freezing cylinder and remove the auger blade. Remove the rear seal and o-ring from the auger.
- L. Remove the drain tray, drip tray and drip tray grid.
- M. Remove the hopper cover and disconnect the auto fill adapter from the cover by pulling out the retaining clip.

**3.5 CLEANING AND SANITIZING THE MACHINE PARTS**

Place all loose parts in a pan or container and take to the wash sink for cleaning. Local and state health codes dictate the procedure required. Some health codes require a four-sink process (pre-wash, wash, rinse, sanitize, and air-dry), while other codes require a three-sink process (without the pre-wash step). The following procedures are a general guideline only. Consult your local and state health codes for procedures required in your location.

- A. Set up a 3-compartment sink with wash, rinse and sanitize compartments. Use only Stera Sheen Green Label or Kay-5 Green. Prepare sanitizer according to manufacturer's instructions to provide a 100ppm strength solution. Set aside a small amount of sanitizer
- B. Clean all parts using brushes provided.
- C. After cleaning, remove the parts and let air dry.



**Figure 3-5 Cleaning Freezing Cylinder**

- D. Sanitize the hopper and freezing cylinder with sanitizer. Be sure to clean the rear seal surfaces inside the freezing cylinder.
- E. Wipe down the outside of the machine and table with a yellow sanitized towel.

### 3.6 ASSEMBLY OF MACHINE

**CAUTION**

Do not allow sanitizer to remain in contact with stainless steel parts for prolonged periods. Prolonged contact of sanitizer with machine may cause corrosion of stainless steel parts.

To assemble the machine parts, refer to the following steps:

**NOTE**

*Petrol Gel sanitary lubricant or equivalent must be used when lubrication of parts is specified.*

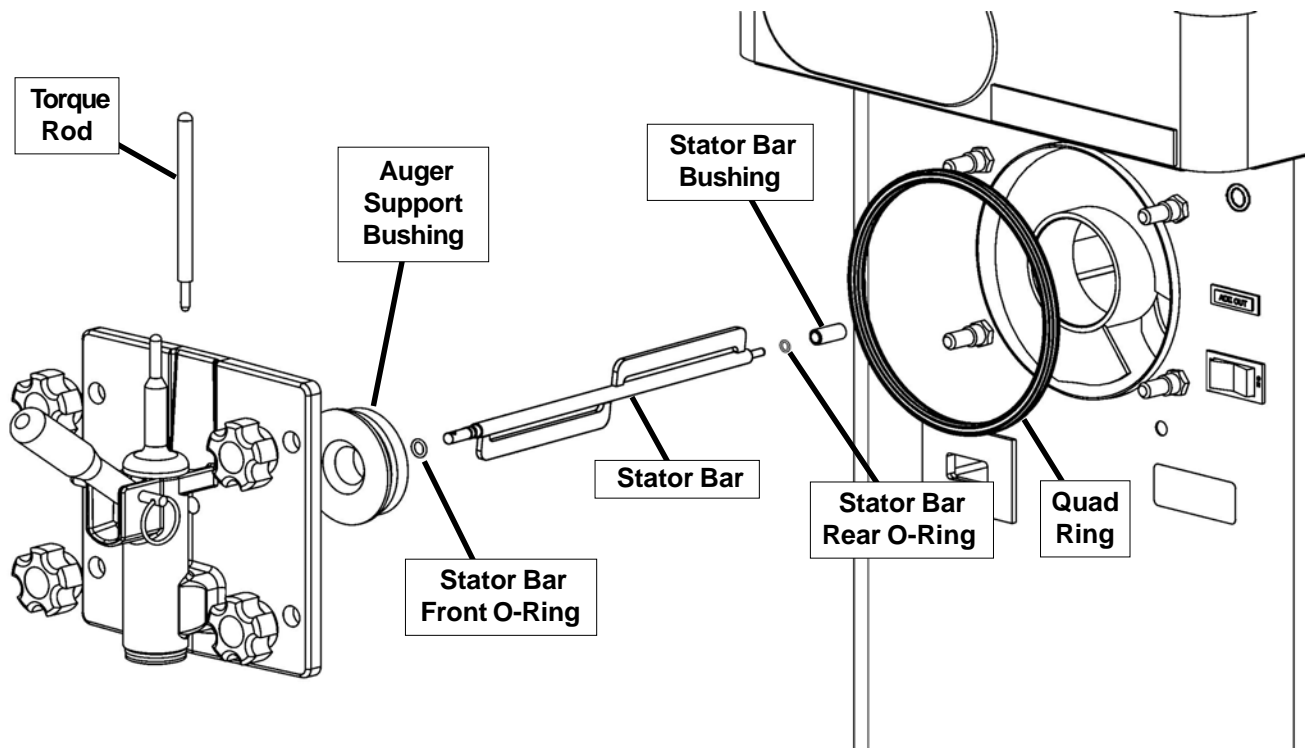
**NOTE**

*The United States Department of Agriculture and the Food and Drug Administration require that lubricants used on food processing equipment be certified for this use. Use lubricants only in accordance with the manufacturer's instructions.*

- A. Wash, rinse, dry and sanitize hands before starting.
- B. Place the rear seal o-ring onto the auger and apply a thin film of Petrol-Gel to the o-ring.
- C. Assemble the rear seal onto the auger with the large end of the seal to the rear. Lubricate the hex end of the auger with a small amount of spline lubricant.
- D. Install the plastic auger blade onto the auger. Push the auger into the freezing cylinder and rotate it slowly until the auger engages the drive shaft.
- E. Assemble the o-rings onto the spigot body and apply a thin film of Petrol-Gel onto the o-rings.
- F. Insert the spigot body into the front door.

**NOTE**

*When inserting the spigot body, press the o-rings against the spigot to prevent damage.*



**figure 3-6 Door and Stator Assembly**

- G. Turn the spigot body until the ice breaker bar can be inserted. Insert the ice breaker bar and rotate spigot body 90°.
- H. Apply Petrol-Gel to the inside and outside of the front auger support bushing. Install the bushing onto the front door so the beveled edge of the bushing is against the door.
- I. Install the large quad ring into the groove in the front door.
- J. Install the o-rings at the front and back of the stator bar. Apply a thin film of Petrol-Gel onto the o-rings. Install the small white bushing to the stator bar.
- K. Insert the stator bar into the front door and insert the torque rod through the hole in the stator bar.
- L. Install the front door onto the freezer. Install the knobs onto the studs.

**NOTE**

*When installing the front door, the torque rod must be placed in the center notch of the torque actuator arm.*

- M. Insert the spigot handle so the hole lines up and insert the spigot pin.
- N. Install the drain tray, drip tray and drip tray grid.

**3.7 SANITIZING**

Sanitizing must be done after the machine is cleaned and just before the hopper is filled with mix. Sanitizing the night before is not effective. However, you should always clean the machine and parts after each use.

The United States Department of Agriculture and the Food and Drug Administration require that all cleaning and sanitizing solutions used with food processing equipment be certified for this use.

When sanitizing the machine, refer to local sanitary regulations for applicable codes and recommended sanitizing products and procedures. The frequency of sanitizing must comply with local health regulations.

Mix sanitizer according to manufacturer's instructions to provide a 100 parts per million (ppm) strength solution and check the solution with chlorine test strips. Mix sanitizer in quantities of no less than 2 gallons (7.5 liters) of 90° to 110°F (32° to 43°C) water. Allow sanitizer to contact the surfaces to be sanitized for 5 minutes. Any sanitizer must be used only in accordance with the manufacturer's instructions.

In general, sanitizing may be conducted as follows:

- A. Prepare Stera-Sheen Green Label Sanitizer according to manufacturer's instructions to provide a 100ppm strength solution. In the blue cleaner/sanitizer bucket, mix 1 packet of sanitizer and 2 gallons of cold water. Check the chlorine content with a test strip to ensure 100ppm strength.
- B. Pour the sanitizing solution into the hopper.
- C. Place the Clean/Off/On switch to Clean.
- D. Use a sanitized barrel brush to sanitize the hopper sides and hopper cover with the sanitizer solution in the hopper.
- E. After 5 minutes, drain the sanitizer solution from the machine into the red utility bucket and discard the solution. Leave a small amount of sanitizer solution in the freezing cylinder.
- F. Place the Clean/Off/On switch Off.
- G. Collect the remaining sanitizer in a clean cup and check the chlorine content with a test strip. If the chlorine content is less than 100ppm, repeat the sanitizing procedure. If the test strip does not read 100ppm after the second test, repeat the disassembly, cleaning and sanitizing procedures.
- H. Connect the auto fill adapter to the hopper cover with the retaining clip and place the hopper cover onto the hopper.
- I. Turn the water line lever to the On position.
- J. Turn the Clean/Off/On switch On. Open the spigot to drain out any remaining sanitizer into the red utility bucket. Close the spigot when mix begins coming out.

**3.8 FREEZE DOWN AND OPERATION**

This section covers the recommended operating procedures for the safe operation of the machine.

- A. After the freezing cylinder is filled, product will be ready to serve in 8 to 12 minutes.
- B. To dispense, pull the spigot handle down to open the spigot.

<b>CAUTION</b>
Do not allow sanitizer to remain in contact with stainless steel parts for prolonged periods. Prolonged contact of sanitizer with machine may cause corrosion of stainless steel parts.

- C. The machine is designed to dispense the product at a reasonable draw rate. If the machine is overdrawn, the result is a wet product or a product that will not dispense at all. If this should occur, allow the machine to run for approximately 30 seconds before dispensing additional product.
- D. Do not operate the machine when the ADD MIX light is on. Immediately check if the auto fill system is operating properly.

**NOTE**

*After 3 hours if the spigot is not opened, the machine will go into defrost mode. During this time, the diagnostic light will be lit and the auger will run for 90 seconds every 7 minutes. Defrost mode maintains consistency in the product and prevents large ice crystals from forming. To end defrost mode, turn the Clean/Off/On switch Off then back On. Defrost mode will also end if the spigot is opened.*

**3.9 MIX INFORMATION**

Mix can vary considerably from one manufacturer to another. Differences in the quantity and quality of ingredients have a direct bearing on the finished frozen product. A change in machine performance that cannot be explained by a technical problem may be related to the mix.

Proper product serving temperature varies from one manufacturer's mix to another. Stackable slush mixes provide satisfactory product from 24° to 28°F (-4° to -2°C).

When checking the temperature, stir the thermometer in the frozen product to obtain an accurate reading.

**3.10 ROUTINE CLEANING**

To remove spilled or dried mix from the machine exterior, wash in the direction of the finish with warm soapy water and wipe dry. Do not use highly abrasive materials as they will mar the finish.

**3.11 PREVENTIVE MAINTENANCE**

Stoelting recommends that a maintenance schedule be followed to keep the machine clean and operating properly.

**B. DAILY**

- 1. The exterior should be kept clean at all times to preserve the luster of the stainless steel. A mild alkaline cleaner is recommended. Use a soft cloth or sponge to apply the cleaner.

**C. WEEKLY**

- 1. Check o-rings and rear seal for excessive wear and replace if necessary.
- 2. Remove the drip tray by gently lifting up to disengage from the support and pulling out. Clean behind the drip tray and front of the machine with a soap solution.

**D. QUARTERLY**

**Air Cooled**

The air-cooled condenser is a copper tube and aluminum fin type. Condensing is totally dependent upon airflow. A plugged condenser filter, condenser, or restrictions in the louvered panel will restrict airflow. This will lower the capacity of the system and damage the compressor.

The condenser must be kept clean of dirt and grease. The F112 must have a minimum of 6" (15.2 cm) of ventilation on the right and left sides of the unit for free flow of air. The E112 must have 3" (7.6 cm) of ventilation. Make sure the machine is not pulling over 100° F (37° C) air from other equipment in the area.

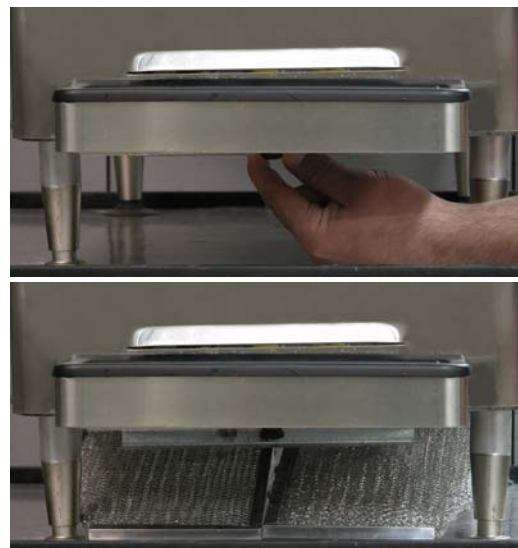
The condenser and condenser filter require periodic cleaning. To clean, refer to the following procedures.

**E112 Air Cooled Condenser Cleaning**

- A. Unscrew the knob located on the underside of the machine towards the front (Fig. 3-7).
- B. Remove the filter bracket and remove the filter.
- C. Visually inspect the condenser filter for dirt.
- D. If the filter is dirty, vacuum or brush clean, rinse with clean water and allow to dry before replacing on the machine.

**NOTE**

*If the condenser is not kept clean, refrigeration efficiency will be lost.*



**Figure 3-7 E112 Condenser Filter Removal**



**Figure 3-8 F112 Condenser Filter Removal**

### F112 Air Cooled Condenser Cleaning

- A. Remove the Phillips head screws from the bottom of the left side panel, and then slide the panel down and out.
- B. To remove the condenser filter, grasp the top and pull off. Visually inspect for dirt. If the filter is dirty, shake or brush excess dirt off the filter and wash in warm, soapy water. Once the filter is clean rinse thoroughly in warm, clear water and shake dry, taking care not to damage the filter in any way (Fig. 3-8).
- C. Visually inspect the condenser for dirt by shining a light through the coil from the back (inside) of the condenser.
- D. If the condenser is dirty, place a wet towel over the front (outside) of the condenser.
- E. Using a vacuum, carefully clean the condenser coil from the inside and outside of the machine. A stiff bristled brush may help in releasing debris from between the condenser coils.

### Water Cooled (F112 only)

The water-cooled condenser is a tube and shell type. The condenser needs a cool, clean supply of water to properly cool the machine, inlet and discharge lines must be 3/8" I.D. minimum. Make sure the machine is receiving an unrestricted supply of cold, clean water.

### E. SEMI-ANNUALLY

1. Disconnect the machine from the power source.
2. Check drive belt for proper tension. Push belt in with one finger, belt should deflect about 3/8".
3. Lubricate condenser fan motor with S.A.E. 20 weight oil. Three to six drops are required.

4. Sanitize the autofill system following the steps below:

### AUTO FILL SANITIZING

- A. If necessary, disassemble, clean and sanitize the machine.

### NOTE

*If the machine does not require cleaning and sanitizing, turn it off and dispense enough product so that the mix level in the hopper is below the long probe. If the mix level is above the long probe, the solenoid will not activate and the pump will not operate.*

- B. Prepare Stera-Sheen Green Label Sanitizer according to manufacturer's instructions to provide a 100ppm strength solution. In the blue cleaner/sanitizer bucket, mix 1 packet of sanitizer and 2 gallons of cold water. Check the chlorine content with a test strip to ensure 100ppm strength.
- C. Cut an adapter from an empty bag of syrup. Connect the adapter to the BIB connector of the syrup line. Put the BIB connector into the bucket of sanitizer.

### NOTE

*If you do not have an empty bag of syrup, remove the plug from the top of the BIB connector. Do not lose the plug; it is needed for proper operation of the BIB.*

Hold the hopper cover over a bucket and set the machine to clean. The solenoid will activate and the brix pump will pump sanitizer into the bucket.

### NOTE

*The solenoid will only activate when there is not any liquid touching the longer mix probe in the hopper.*

- E. After all the sanitizer has run through the pump, turn the machine off.
- F. Disconnect the bag adapter from the BIB connector (or reinsert the plug into the connector). Connect the BIB connector to the syrup BIB.
- G. Set the machine to clean and hold the hopper cover over a bucket. This will flush the sanitizer out of the pump and tubing. When pure syrup comes out of the tubing, turn the machine off.

The machine is now ready to operate. Place the hopper cover on the hopper and turn the machine on.

### 3.12 EXTENDED STORAGE

Refer to the following steps for storage of the machine over any long period of shutdown time:

- A. Follow the cleaning and sanitizing procedures for the machine and follow the semi-annual instructions to sanitize the auto fill system.
- B. Place the CLEAN-OFF-ON switch in the OFF (middle) position.
- C. Disconnect (unplug) from the electrical supply source.
- D. Clean thoroughly with a warm water detergent all parts that come in contact with the mix. Rinse in clean water and dry parts. Do not sanitize.

#### **NOTE**

*Do not let the cleaning solution stand in the hopper or in the freezing cylinder during the shutdown period.*

- E. Remove, disassemble and clean the front door, mix inlet regulator and auger parts.
- F. In a water cooled machine, disconnect water lines and drain water. With a flathead screwdriver, hold the water valve open and use compressed air to clear the lines of any remaining water.

## SECTION 4 MAINTENANCE AND ADJUSTMENTS

### 4.1 MACHINE ADJUSTMENT

This section is intended to provide maintenance personnel with a general understanding of the machine adjustments. It is recommended that any adjustments in this section be made by a qualified person.

### 4.2 PRODUCT CONSISTENCY ADJUSTMENT

The Consistency Adjustment Knob increases or decreases product consistency by changing the amount of torque needed to complete a refrigeration cycle. Turn the knob clockwise to increase consistency and counterclockwise to decrease consistency.

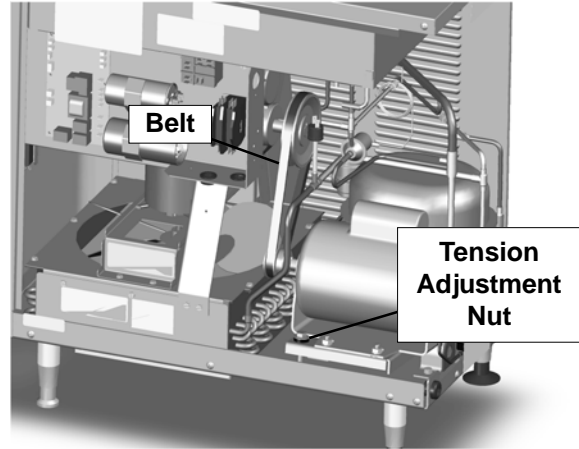


Figure 4-1 Belt Tension

### 4.3 DRIVE BELT TENSION ADJUSTMENT

To check belt tension, refer to Figure 4-2 and follow the steps below:

- A. Remove the right side panel.
- B. Use a Burroughs Belt Tension Gauge to set the tension for the drive belt. Set the E112 belt tension to 5-15 lbs. Set the F112 belt tension to 30-40 lbs.
- D. If an adjustment is necessary, loosen the four motor plate retaining nuts, adjust belt tension then retighten the four nuts.

**NOTE**

*Belt life will be increased if new drive belts are checked after two or three weeks of operation.*

- A. Turn off the water supply and relieve pressure in the line by opening the spigot.
- B. Loosen the screw. Turn the cartridge and pull it out of the housing.

**NOTE**

*Disassemble the cartridges separately to ensure the inlet and outlet parts remain with the correct cartridge.*

- C. Inspect the duckbill valve for a tight seal in the closed position.
- D. The valve should have a quick action when pressed open and the material should not be hard or stiff.
- E. Replace the valve and o-ring if necessary.
- F. Reassemble the cartridge and install it into the housing on the pump.

### 4.4 AUTO FILL PUMP MAINTENANCE

After prolonged periods without sanitizing, the pump valves could become stiff or clogged. If this is suspected, the valve cartridges can be removed for inspection. There are four cartridges in the pump, two inlet and two outlet.

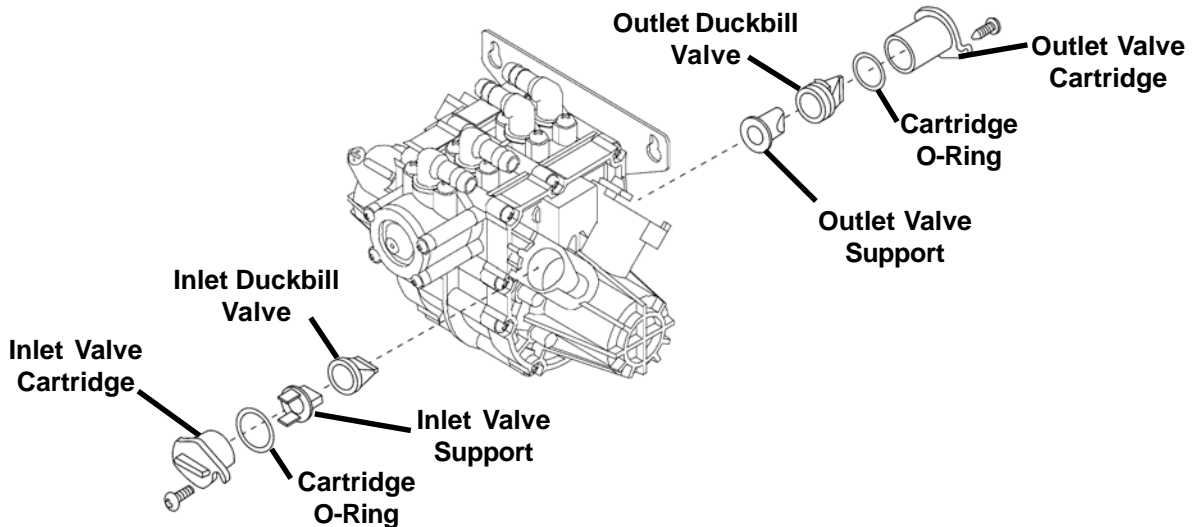


Figure 4-2 Auto Fill Pump Valves



# SECTION 5 REFRIGERATION SYSTEM

## 5.1 REFRIGERATION SYSTEM

The E112-LJ and F112-LJ refrigeration systems have two functions:

Medium-Temperature - Maintaining product temperature in the hopper.

Low-Temperature - Producing and maintaining high quality product in the freezing cylinder.

The system is designed for efficient use with R404A refrigerant. The proper charge is indicated on the information plate.

## NOTE

*For qualified service personnel only. Anybody working with refrigerants must be certified as a Technician TYPE I as required by 40 CFR 82 Subpart F and hold all State and/or local refrigerant handling certifications. In addition, all handling, storage, and disposal of refrigerants must be in accordance with Environmental Protection Agency (EPA) guidelines and standards and all State and local guidelines and standards.*

## 5.2 REFRIGERANT RECOVERY AND EVACUATION

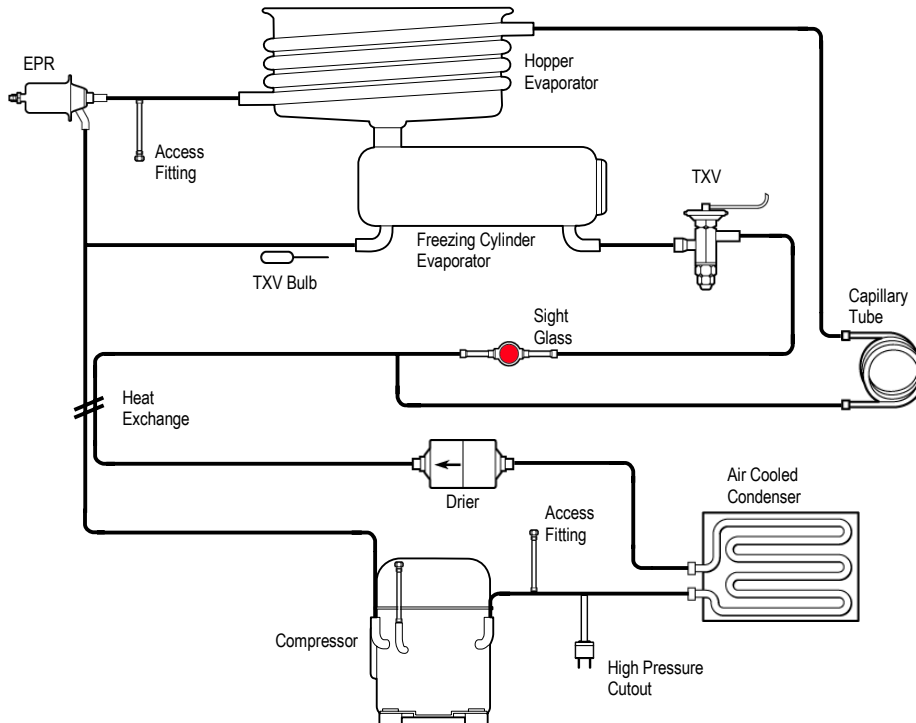
Refer to the following procedures to properly recover and evacuate the refrigeration system. Do not purge refrigerant into the atmosphere.



## WARNING

### Hazardous voltage

The CLEAN-OFF-ON switch must be placed in the OFF position when disassembling for servicing. The machine must be disconnected from electrical supply before removing any access panel. Failure to disconnect power before servicing could result in death or serious injury.



**Figure 5-1 F112-LJ Refrigeration Diagram**

- A. Disconnect the machine from electrical supply before removing any panels for servicing.
- B. Remove the right side panel.
- C. If evacuating the system, connect a vacuum gauge to the Schrader valve next to the evaporator.
- D. Connect the recovery or evacuation unit to the suction and discharge service valves of the compressor.
- E. Perform the recovery or evacuation:
  - For recovery
    - Operate the recovery unit per manufacturer's instructions.
  - For evacuation
    - Evacuate the system until the gauge reads 300 microns of mercury (300 $\mu$  Hg). Turn off evacuation unit and wait 5 minutes.
    - If the gauge stays below 500 $\mu$  Hg, the system is properly evacuated.
    - If the gauge slowly rises to 1500-2000 $\mu$  Hg, there is still moisture in the system and further evacuation is required.
    - If the gauge rises to atmosphere, the system has a leak which must be resolved before continuing.
- F. Remove evacuation or recovery unit and gauge.

- B. If the system has been opened or if there was a leak, refer to Section 5.2 - Refrigerant Recovery and Evacuation to evacuate the system prior to charging.
- C. Refer to machine's information plate for total charge requirements.

**NOTE**

*The refrigeration systems of the E112-LJ and F112-LJ are critically charged. Be sure to charge the system to the weight listed on the machine's information plate.*

- D. For liquid refrigerant charging, connect refrigerant cylinder to the discharge Schrader valve of the compressor.
- E. Add the proper amount of refrigerant according to the machine's information plate.

**5.4 COMPRESSOR**

The E112-LJ and F112-LJ have hermetic reciprocating compressors (Refer to Figures 5-2 and 5-3).

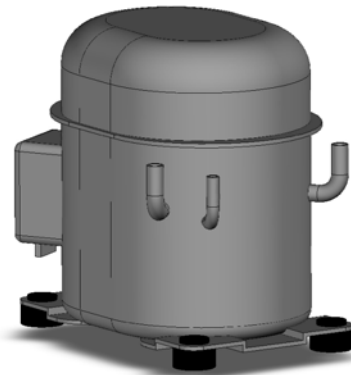
**5.3 REFRIGERANT CHARGING**

Refer to the following procedures to properly charge the refrigeration system. Stoelting recommends liquid refrigerant charging.

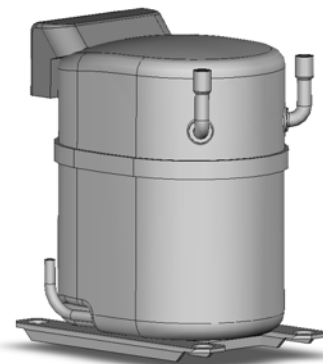
**NOTE**

*For qualified service personnel only. Anybody working with refrigerants must be certified as a Technician TYPE I as required by 40 CFR 82 Subpart F and hold all State and/or local refrigerant handling certifications. In addition, all handling, storage, and disposal of refrigerants must be in accordance with Environmental Protection Agency (EPA) guidelines and standards and all State and local guidelines and standards.*

- A. Ensure the electrical supply has been removed before continuing.



**Figure 5-2 E112-LJ Compressor**



**Figure 5-3 F112-LJ Compressor**



**WARNING**

**Hazardous voltage**

The CLEAN-OFF-ON switch must be placed in the OFF position when disassembling for servicing. The machine must be disconnected from electrical supply before removing any access panel. Failure to disconnect power before servicing could result in death or serious injury.

## A. WINDING TEST

To test the compressor motor windings for possible problems, perform the following steps:

- A. Disconnect the machine from electrical supply before removing any panels for servicing.
- B. Remove the right side panel.
- C. Remove the protective cover from the compressor terminals. Disconnect the three terminals; C (common), R (run), and S (start).
- D. Connect an ohmmeter to the C and R terminals on the compressor. Resistance through the run winding should be as follows:  
E112-LJ -  $0.6\Omega \pm 10\%$   
F112-LJ -  $1.4\Omega \pm 10\%$
- E. Connect an ohmmeter to the C and S terminals on the compressor. Resistance through the start winding should be as follows:  
E112-LJ -  $4.0\Omega \pm 10\%$   
F112-LJ -  $2.6\Omega \pm 10\%$
- F. To check if windings are shorted to ground, connect one ohmmeter lead to a bare metal part on the compressor (such as any copper line leading to or from the compressor) and check terminals C, R, and S.

### NOTE

*The compressor is equipped with an internal overload protector. If the compressor is warm and ohmmeter readings indicate an open winding, allow up to one hour for overload to reset.*

## B. COMPRESSOR REMOVAL

### E112-LJ COMPRESSOR REMOVAL

- A. Disconnect the machine from electrical supply before removing any panels for servicing.
- B. Remove the protective cover from the compressor terminals and disconnect the wires.
- C. Recover refrigerant charge per the instructions in Section 5.2.
- D. Leave a port open to prevent pressure buildup during compressor removal.
- E. Remove six inches of insulating tubing on the suction line going to the compressor and unsweat the suction and discharge line from the compressor.
- F. Remove the four nuts and washers from the base of the compressor.
- G. Remove the compressor through the side of the machine.
- H. Remove the four rubber compressor mounts from the compressor.
- I. Plug all open ports of the old compressor.

## NOTE

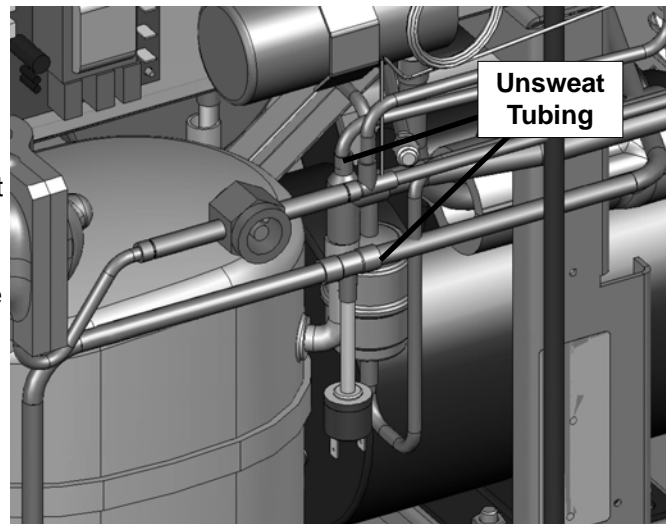
*A compressor returned to Stoelting with any open ports will void the warranty. ALWAYS plug ports on a compressor that has been removed.*

### F112-LJ COMPRESSOR REMOVAL

- A. Disconnect the machine from electrical supply before removing any panels for servicing.
- B. Remove the protective cover from the compressor terminals and disconnect the wires.
- C. Recover refrigerant charge per the instructions in Section 5.2.
- D. Leave a port open to prevent pressure buildup during compressor removal.
- E. Remove the insulation around the tubing on the suction line going to the compressor and unsweat the suction line from the compressor. (Fig. 5-4)
- F. Apply a heat sink (wet cloth) to the high pressure cutout and unsweat the tubing at the tee.
- G. Remove the four nuts and washers from the base of the compressor.
- H. Remove the compressor through the right side of the machine by tilting the compressor base outward.
- I. Remove the four rubber compressor mounts from the compressor.
- J. Apply a heat sink to the high pressure cutout and unsweat the discharge line from the compressor.
- K. Unsweat the suction line access fitting from the compressor.
- I. Plug all open ports of the old compressor.

## NOTE

*A compressor returned to Stoelting with any open ports will void the warranty. ALWAYS plug ports on a compressor that has been removed.*



**Figure 5-4 Compressor Removal - F112-LJ**

## C. COMPRESSOR INSTALLATION

### E112-LJ COMPRESSOR INSTALLATION

- A. Make sure the machine is disconnected from the electrical supply before servicing.
- B. Install the four rubber mounts on the compressor.
- C. Install the compressor into the machine, fitting the base over the four bolt holes.
- D. Install the four washers and nuts onto the bolts and tighten securely.
- E. Remove all tubing plugs from the replacement compressor.

#### NOTE

*The compressor plugs protect the compressor from moisture in the air. Do not remove the plugs until you are ready to install. The compressor must not be opened to the atmosphere for more than 10 minutes.*

- F. Leave a port open to prevent pressure buildup. Braze the suction and discharge line to the compressor.
- G. Connect the wires to the compressor terminals.
- H. Replace the drier per the instructions in Section 5.8.
- I. Evacuate the system per the instructions in Section 5.2
- J. Recharge the system per the instructions in Section 5.3.
- K. Replace the insulating tubing on the suction line.

### F112-LJ COMPRESSOR INSTALLATION

- A. Make sure the machine is disconnected from the electrical supply before servicing.
- B. Remove all tubing plugs from the replacement compressor.

#### NOTE

*The compressor plugs protect the compressor from moisture in the air. Do not remove the plugs until you are ready to install. The compressor must not be opened to the atmosphere for more than 10 minutes.*

- C. Apply a heat sink (wet cloth) to the high pressure cutout and braze the tubing to the compressor.
- D. With the port open, braze the access fitting to the compressor.
- E. Install the four rubber mounts on the compressor.
- F. Install the compressor into the machine, fitting the base over the four bolt holes.
- G. Install the four washers and nuts onto the bolts and tighten securely.

- H. Leave a port open to prevent pressure buildup. Braze the suction line to the compressor.
- I. Apply a heat sink (wet cloth) to the high pressure cutout and braze the tee to the refrigeration line.
- J. Connect the wires to the compressor terminals.
- K. Replace the drier per the instructions in Section 5.8.
- L. Evacuate the system per the instructions in Section 5.2
- M. Recharge the system per the instructions in Section 5.3.
- N. Replace the insulating tubing on the suction line.

## 5.5 CONDENSER

The E112-LJ has an air-cooled condenser. The F112-LJ has either an air-cooled or water-cooled condenser. The capacity of the machine is directly related to keeping the condenser clean and free of debris, regardless of cooling type.

The air-cooled condenser is a copper tube and aluminum fin type. The E112-LJ must have a minimum of 3" of clearance on the sides and the underside must be kept clear for proper air flow. The F112-LJ must have a minimum of 6" of clearance on the sides.

The water-cooled condenser on an F112-LJ is a tube and shell type. This condenser requires cool, clean water to function properly. Inlet and discharge lines must be 3/8" ID minimum.

### CONDENSER TESTING

The condenser can be checked for leaks using the bubble test or using a leak detector.

## 5.6 VALVES

### A. THERMOSTATIC EXPANSION VALVE (TXV)

The Thermostatic Expansion Valve (TXV) is used to meter the refrigerant to the evaporator. It does so by maintaining a low, constant superheat in the evaporator. The self-regulating TXV is preset by the manufacturer and adjustment is not recommended. (Fig. 5-5)

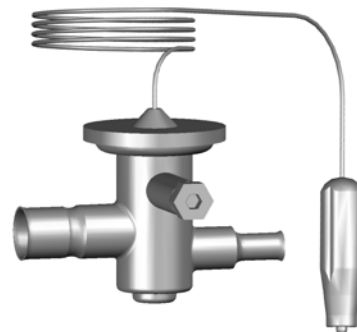


Figure 5-5 TXV

## TXV TESTING & ADJUSTMENT

### NOTE

*The TXV bulb has an indent which must be positioned against the tubing. Good contact between the bulb and the suction line is necessary for proper operation of the valve. The bulb must also be well insulated.*

- A. Connect a gauge to the Schrader valve on the suction line.
- B. Connect a thermocouple to the suction line next to the evaporator. Make sure the thermocouple is making direct contact with the suction line and insulate the thermocouple to obtain a correct reading.
- C. Immediately before the refrigeration cycle ends, the superheat should be 7-10°F. This temperature is based on a full load in the freezing cylinder and an ambient temperature of 70°F. The gauge should read the following:  
E112-LJ: 20-22 psig  
F112-LJ: 30-32 psig
- D. If the readings are higher than expected, check to see if there is an overcharge of refrigerant. Also make sure the TXV bulb is making good contact with the suction line and it is well insulated.
- E. If the readings are lower than expected, check to see if there is a low refrigerant charge or if there is a restriction in the system.

### NOTE

*The TXV is the LAST component to adjust in the refrigeration system.*

- F. The TXV can be adjusted after the steps above are completed. When adjusting, do not turn the valve over 1/4 turn (90°). Turn the valve stem clockwise to increase the superheat or counterclockwise to decrease the superheat.

## TXV REMOVAL

- A. Remove the side panel.
- B. Remove bulb from suction line exiting from the evaporator.
- C. Recover refrigerant charge per instructions in Section 5.2.
- D. Leave a port open to prevent pressure buildup during TXV removal.
- E. Remove any insulation from the TXV and immediate surrounding lines.
- F. Apply a heat sink (wet cloth) to the valve dome.
- G. Unsweat the TXV and remove.

## TXV REPLACEMENT

To replace the TXV, perform the following procedures:

- A. Position the TXV with a heat sink into the system.
- B. With an open port, braze the TXV into the system using appropriate brazing material.
- C. Remove the heat sink from the TXV.
- D. Install bulb on suction line exiting the evaporator using existing clamp. The bulb has an indent which must be placed against the tubing.

### NOTE

*The TXV bulb should ALWAYS be mounted on the horizontal line, with the capillary end facing the flow of refrigerant. Good contact between the bulb and the suction line is necessary for proper operation of the valve. The bulb must also be well insulated.*

- E. Tighten clamp to 20 in/lb using a torque wrench.
- F. Replace insulation to the TXV and surrounding lines.
- G. Replace the drier per the instructions in Section 5.9.
- H. Evacuate the system per the instructions in Section 5.2.
- I. Recharge the system per the instructions in Section 5.3.

## B. HIGH PRESSURE CUTOUT

The high pressure cutout stops the compressor if the discharge pressure reaches 445 psig (Refer to Figure 5-6).



Figure 5-6 High Pressure Cutout

## HIGH PRESSURE CUTOUT TEST

- A. Connect a gauge to the Schrader valve on the discharge line.

- B. Disconnect cooling:  
Air-Cooled - Disconnect evaporator fan  
Water-Cooled - Shut off water supply
- C. High pressure cutout should trip when pressure reaches 445 psig  $\pm$ 9.

**HIGH PRESSURE CUTOUT REMOVAL**

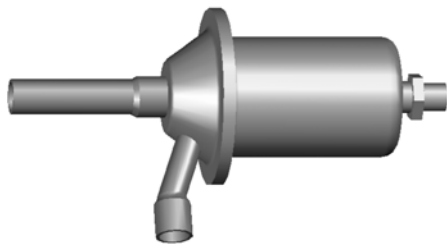
- A. Remove the right side panel.
- B. Disconnect terminals from high pressure cutout.
- C. Recover refrigerant charge per instructions in Section 5.2.
- D. Leave a port open to prevent pressure buildup during removal.
- E. Apply a heat sink (wet cloth) to the cutout.
- F. Unsweat cutout from discharge line.

**HIGH PRESSURE CUTOUT REPLACEMENT**

- A. Apply a heat sink (wet cloth) to the new cutout.
- B. With an open port, braze the cutout to the discharge line.
- C. Replace the drier per the instructions in Section 5.9.
- D. Evacuate the system per the instructions in Section 5.2.
- E. Recharge the system per the instructions in Section 5.3.
- F. Connect the high pressure cutout.

**C. EVAPORATOR PRESSURE REGULATOR (EPR)**

There is one EPR in the refrigeration system (Refer to Figure 5-7). It is located on the suction line of the hopper evaporator and regulates refrigerant pressure.



**Figure 5-7 EPR Valve**

**EPR TEST AND ADJUSTMENT**

- A. Place the CLEAN/OFF/ON switch in the OFF position.
- B. Connect a gauge to the Schrader valve on the suction line.
- C. Place the CLEAN/OFF/ON switch to the ON position.
- D. If the gauge does not read 60 psig  $\pm$ 2 then adjustment is needed.

- E. Remove the plastic cap and loosen the locknut on the EPR. Using a small screwdriver, turn the adjustment screw counterclockwise 1/2 turn, then adjust as necessary. Turn the valve stem clockwise for less cooling or counterclockwise for more cooling.
- F. Allow the system to stabilize for 5 minutes to ensure pressure remains stable.

**EPR REMOVAL**

- A. Remove the side panel.
- B. Recover refrigerant charge per instructions in Section 5.2.
- C. Leave a port open to prevent pressure buildup during EPR removal.
- D. Unsweat the EPR and remove.

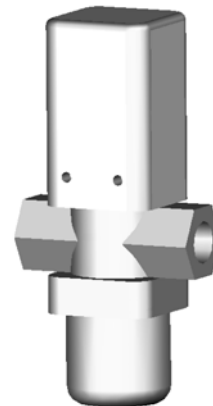
**EPR REPLACEMENT**

To replace the EPR, perform the following procedures:

- A. Apply a heat sink (wet cloth) to the EPR.
- B. With an open port, braze the EPR into the system using appropriate brazing material.
- C. Remove the heat sink from the hot gas bypass.
- D. Replace the filter drier. Refer to Section 5.8 for details.
- E. Evacuate and recharge system per instructions in Section 5.2.
- F. Adjust the suction pressure to 60 psig  $\pm$ 2.

**D. WATER VALVE (WATER COOLED MODELS ONLY)**

The water valve monitors refrigerant pressure and opens on an increase of pressure. The opening point pressure is the refrigerant pressure required to lift the valve disc off the valve seat. (Figure 5-7)



**Figure 5-8 Water Valve**

**WATER VALVE ADJUSTMENT**

- A. Remove the back panel.
- B. Connect a gauge to the compressor discharge Schrader valve.

- C. Take the temperature of the inlet water.
- D. Connect the machine to the electrical supply, start the refrigeration cycle, and read the pressure.
- D. Refer to the chart below for correct pressures and water outlet temperatures:
- F. Replace the filter drier. Refer to Section 5.8 for details.
- G. Evacuate and recharge system per instructions in Section 5.2.
- H. Turn on the water and check for leaks in the water lines with the refrigeration system running.
- I. Adjust the valve as necessary.

Inlet Water Temperature	Discharge Pressure	Outlet Water Temperature
60°F	225-235 psig	81° - 93°F
70°F	227-237 psig	83° - 95°F
80°F	229-239 psig	84° - 96°F
90°F	248-258 psig	90° - 102°F
100°F	282-292 psig	100° - 112°F
110°F	317-327 psig	109° - 121°F

**Table 5-1 Water Cooled Pressure/Temperature Table**

- E. If the water temperature is too low, the opening point pressure should be increased to slow the water flow. Turn the adjustment screw counterclockwise.
- F. If the water temperature is too high, the opening point pressure should be decreased to increase the flow of water. Turn the adjustment screw clockwise.

**WATER VALVE REMOVAL**

The water valve is connected to the refrigeration system by capillary tube brazed to the discharge line.

- A. Turn off and disconnect the water supply. Blow out the water lines with compressed air or CO<sub>2</sub>.
- B. Recover refrigerant charge per instructions in Section 5.2.
- C. Unsweat the capillary tube from the discharge line.
- E. Remove the clamps from the water lines at the valve.
- F. Remove the two screws holding the water valve to the frame and remove the valve.

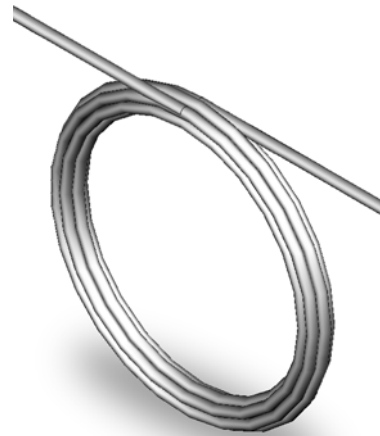
**WATER VALVE REPLACEMENT**

To replace the water valve, perform the following procedures:

- A. Position the water valve and attach to the frame using the two screws.
- B. Install the water lines onto the valve with hose clamps.
- C. Braze the capillary tube into the system using BCuP-3 or BCuP-5 brazing material.
- D. Connect the water supply line and turn on the water supply.
- E. Check for leaks in the water lines. If there are no leaks, turn off the water supply.

**5.7 CAPILLARY TUBE**

The capillary tube meters refrigerant flow in the hopper evaporator (Refer to Figure 5-9). The amount of flow is dependent on the length and ID of the capillary tube as well as the refrigerant charge.



**Figure 5-9 Capillary Tube**

**CAPILLARY TUBE REMOVAL**

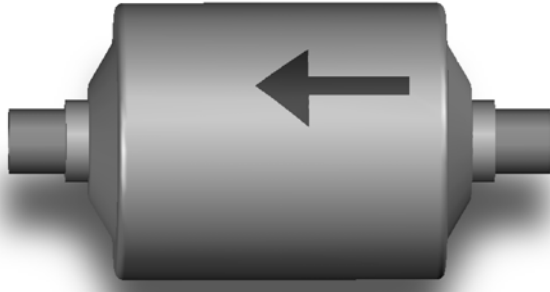
- A. Recover refrigerant charge per instructions in Section 5.2.
- B. Leave a port open to prevent pressure buildup during capillary tube removal.
- C. Remove foam insulation from the capillary tube at the evaporator inlet.
- C. Unsweat the capillary tube and remove.

**CAPILLARY TUBE REPLACEMENT**

- A. Position the capillary tube in place.
- B. Apply a heat sink (wet cloth) to the capillary tube and drier assembly.
- C. With an open port, braze the capillary tube into the system using appropriate brazing material.
- D. Replace foam insulation to the capillary tube at the evaporator inlet.
- E. Evacuate the system per instructions in Section 5.2.
- F. Recharge the system per instructions in Section 5.3.

## 5.8 FILTER DRIER

The filter drier must be replaced every time the refrigeration system is opened for service. A new filter drier improves operation of the entire refrigeration system by stopping the circulation of moisture and by removing harmful contaminants (Refer to Figure 5-10).



**Figure 5-10 Filter Drier**

### FILTER DRIER REMOVAL

- A. Recover refrigerant charge per instructions in Section 5.2.
- B. Cut the refrigeration line as close to the filter drier as possible and remove drier.
- C. Cap the ends of the drier using the plugs from the new drier.

#### **NOTE**

*The drier must be capped to prevent moisture from the environment*

### FILTER DRIER REPLACEMENT

- A. Position the filter drier so the arrow is pointing towards the evaporators (pointing away from the condenser).
- B. Apply a heat sink (wet cloth) to the filter drier.
- C. With an open port, braze the filter drier into the system using appropriate brazing material.
- D. Evacuate the system per instructions in Section 5.2.
- E. Recharge the system per instructions in Section 5.3.

## SECTION 6 ELECTRICAL AND MECHANICAL CONTROL SYSTEMS

### NOTE

The wiring diagrams are located in Section 8.

### 6.1 CONTROL BOARD

The control board uses a microprocessor to control all timing and mode operations. It processes information from the motor and spigot and sends signals to the compressor and motor.

### NOTE

The control board is designed for use at 115VAC or 208-240VAC. A connector and resistor determine the voltage setting of the control board. Refer to Figure 6-1 for the location of the connector and resistor.

### CONTROL BOARD TEST

The following test will show if the control board has proper voltage.

1. Open the right side panel.
2. When the CLEAN-OFF-ON switch is in the ON position, read voltage on the control board across the L1 terminal and one of the neutral terminals (P2, P3, P4 or P5). Voltage should be near line voltage (115VAC on E112-LJ and 220VAC on F112-LJ).

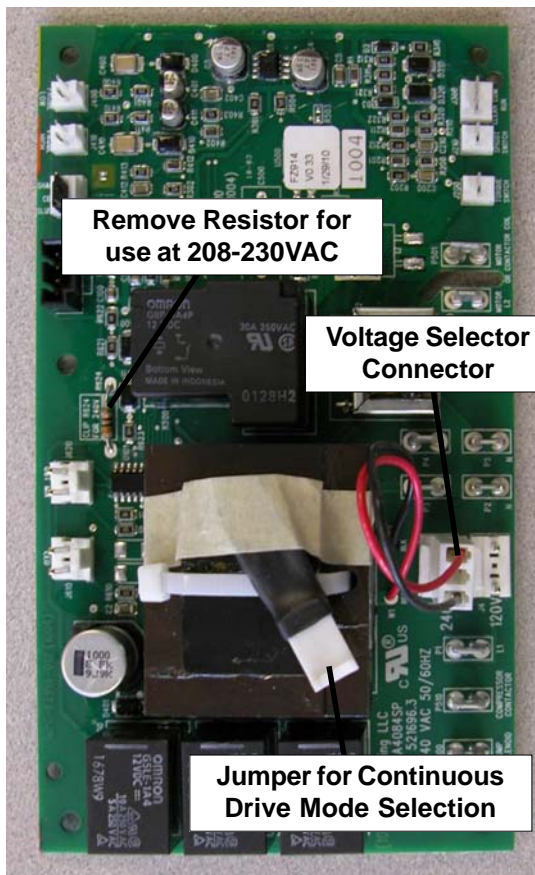


Figure 6-1 Control Board



### WARNING

Service to the machine must be completed by a qualified electrician/refrigeration specialist. Any tests or work done on the machine must be done by a qualified technician. Service to the machine done by an unqualified person, could result in serious personal injury.

### 6.2 CONTACTORS

The compressor and drive motor contactors are mounted behind the right panel.

#### A. CONTACTOR TESTS

The following test will show if the control board is sending a voltage signal to the contactor.

1. Open the right side panel.
2. When the CLEAN-OFF-ON switch is in the ON position, read voltage on the control board across the L1 terminal and one of the neutral terminals (P2, P3, P4 or P5). Voltage should be near line voltage (115VAC on E112 and 220VAC on F112).
3. Read voltage on the control board across the L1 terminal and the COMPRESSOR CONTACTOR or MOTOR CONTACTOR terminal during a freezing cycle. Voltage should be 0V.

The following test will show if a contactor is receiving a voltage signal from the control board.

1. Open the right side panel.
2. Read voltage across the coils of the contactor during a freezing cycle. Voltage should be near line voltage (115VAC on E112 and 220VAC on F112). If there is no voltage reading, refer to Section 7 Troubleshooting.

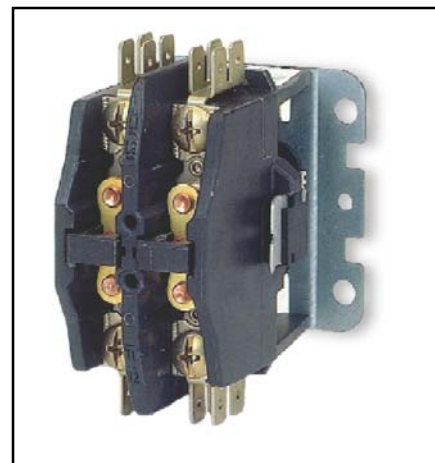


Figure 6-2 Contactor

## 6.3 DRIVE MOTOR

The drive motor is used to rotate the auger assembly. An internal, normally closed, centrifugal switch starts the drive motor. The motor has an internal thermal overload.

### A. DRIVE MOTOR VOLTAGE TEST

The following test will show if the relay on the control board is working properly and sending a voltage signal to the drive motor.

1. Open the right side panel.
2. When the CLEAN-OFF-ON switch is in the ON position, read voltage on the control board across the L1 terminal and one of the neutral terminals (P2, P3, P4 or P5). Voltage should be near line voltage (115VAC on E112-LJ and 220VAC on F112-LJ).
3. Read voltage across the L1 terminal and the AUGER terminal. Voltage should be 0V.

### B. DRIVE MOTOR REPLACEMENT

#### E112 MOTOR REMOVAL

1. Disconnect machine from electrical supply before removing any panels for servicing.
2. Remove the back panel and the right side panel.
3. Remove the ground wire from the machine frame.
4. Loosen the motor cradle clamps at the front and back of the motor.
5. Rotate the motor so that the electrical cover plate can be removed. Remove the cover plate from the back of the motor.
6. Identify (mark) wires and remove them from the motor.
7. Remove the belt tension adjustment nut and remove the belt.
8. Remove the two bolts from the bushing clamp at the rear of the machine and pull the motor out through the back of the machine.

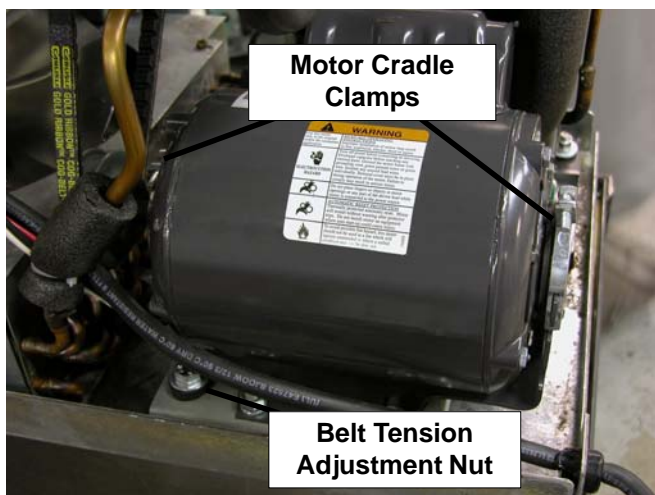


Figure 6-3 Drive Motor

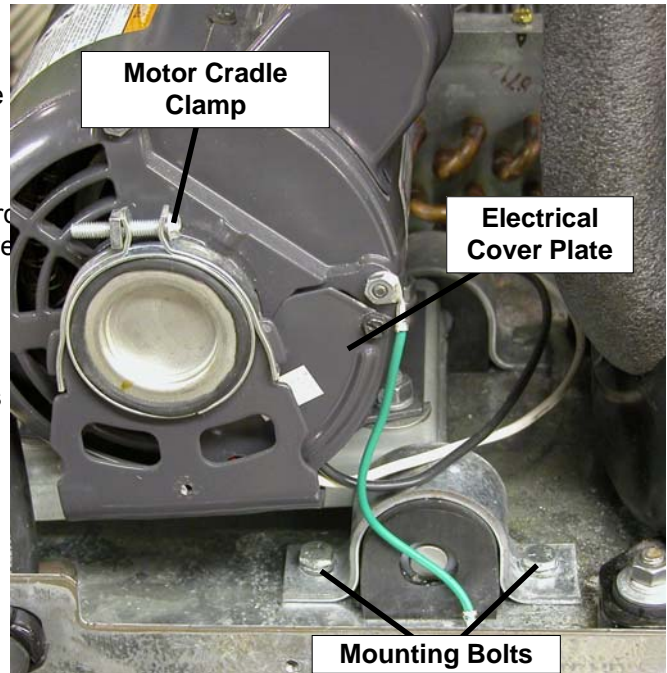


Figure 6-4 Drive Motor

9. Remove the bolts that connect the motor to the mounting plate.
10. Loosen the two allen head screws from the pulley.
11. Remove the pulley and key from the motor shaft.

#### E112 MOTOR INSTALLATION

1. Place the drive motor on the mounting plate and install the four mounting bolts.
2. Place the pulley and key on the motor shaft.

#### NOTE

*Do not tighten the pulley screws until after the belt tension has been properly adjusted.*

3. Install the motor and mounting plate in the machine to the bushing clamp using the mounting bolts.
4. Install the belt and the tension bolt. Tighten the tension bolt.
5. Test for proper belt tension by pressing firmly on the belt. When the tension is properly adjusted, the belt should depress approximately 3/8" (roughly the width of the belt).
6. Using a straightedge, align the drive motor pulley with the gearbox pulley. Tighten the two allen head screws on the drive motor pulley.
7. Loosen the motor cradle clamps at the front and back of the motor.
8. Rotate the motor so that the electrical cover plate can be removed. Remove the cover plate from the back of the motor
9. Install wiring according to the wiring diagram. Install the electrical cover plate.
10. Tighten the motor cradle clamps.
11. Install back and side panels.

## F112 MOTOR REMOVAL

1. Disconnect machine from electrical supply before removing any panels for servicing.
2. Remove the back panel and the right side panel.
3. Remove the electrical cover plate from the back of the motor.
4. Identify (mark) wires and remove them from the motor.
5. Loosen the belt tension adjustment nut and remove the belt.
6. Remove the motor mounting bolts.
7. Remove the motor through the back of the machine.
8. Loosen the two allen head screws from the pulley.
9. Remove the pulley and key from the motor shaft.

## F112 MOTOR INSTALLATION

1. Place the pulley and key on the motor shaft.

### NOTE

*Do not tighten the pulley screws until after the belt tension has been properly adjusted.*

2. Place the drive motor in position and install the four mounting bolts.
3. Install the belt and tighten the tension bolt.
4. Test for proper belt tension by pressing firmly on the belt. When the tension is properly adjusted, the belt should depress approximately 3/8" (roughly the width of the belt).
5. Using a straightedge, align the drive motor pulley with the gearbox pulley. Tighten the two allen head screws.
6. Install wiring according to wiring diagram. Install electrical cover plate.
7. Install back and side panels.

## 6.4 CAPACITORS

The compressor start and run capacitors are mounted behind the right side panel. The capacitors for the drive motor are mounted directly onto the motor body. The E112-LJ has one drive motor capacitor. The F112-LJ has two drive motor capacitors: a run capacitor and a start capacitor.

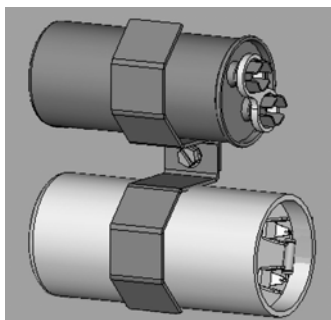


Figure 6-5 Compressor Capacitors

## A. CAPACITOR TEST

1. Place the CLEAN-OFF-ON switch in the OFF position.
2. Remove a lead from one of the capacitor terminals.
3. Using insulated pliers, discharge the capacitor by connecting a 20K  $\Omega$  5W resistor across the terminals.

### NOTE

*Discharge the capacitor even if there is a bleeder resistor across the terminals. There may be an open in the bleeder resistor preventing it from working properly.*

4. Disconnect the bleeder resistor from the circuit.
5. Measure capacitance across the terminals. The results should be as follows:

E112-LJ	Part	Rating	
		MFD	VAC
Drive Motor	230440	378-454 MFD	110 VAC
Compressor Start	231058	145-174 MFD	250 VAC
Compressor Run	230648	25 MFD	440 VAC

F112-LJ	Part	Rating	
		MFD	VAC
Drive Motor Start	231095	500 MFD	125 VAC
Drive Motor Run	231078	50 MFD	370 VAC
Compressor Start	230632	72-86 MFD	330 VAC
Compressor Run	230633	30 MFD	370 VAC

6. Check the resistance across the capacitor terminals. The reading should be close to 0 and will rise slowly (as the meter charges the capacitor).
6. If the resistance stops increasing, there may be an internal short in the capacitor.
7. Discharge the capacitor if the test needs to be repeated.

## B. CAPACITOR REPLACEMENT

1. Place the CLEAN-OFF-ON switch in the OFF position.
2. Remove leads from the capacitor terminals.
3. Using insulated pliers, discharge the capacitor by connecting a 20K  $\Omega$  5W resistor across the terminals.

### NOTE

*Discharge the capacitor even if there is a bleeder resistor across the terminals. There may be an open in the bleeder resistor preventing it from working properly.*

4. Pull the capacitor out of its holder and replace.
5. Connect the leads to the terminals.

## 6.5 GEARBOX

### A. GEARBOX INSPECTION

Inspect the gearbox and listen for unusual noise. A grinding sound generally indicates a bad gear.

### B. GEARBOX REMOVAL

1. Disconnect machine from electrical supply before removing any panels for servicing.
2. Remove the back panel and the side panel.
3. Remove protective shield from side of machine.
4. Remove the belts.
5. Remove the pulley by loosening the set screws.
6. Remove the three bolts holding the gearbox to the barrel.
4. Remove the two bolts holding the gearbox to the mounting bracket and remove the gear box through 3. the rear of the machine.

### C. GEARBOX INSTALLATION

1. Place the gear box in position from the rear of the machine. Fasten the three bolts through the gear box to the rear of the barrel.
2. Fasten the gearbox to the mounting bracket using 5. the two bolts.
3. Mount the pulley on the gear box shaft and align with the motor pulley, then tighten the allen head screws.
4. Install the belt.
5. Press firmly on the belt.
6. When the tension is properly adjusted, the belt will depress the approximate width of the belt with the pressure of a finger.
7. If an adjustment is necessary, loosen the four motor plate retaining nuts, adjust belt tension then retighten the four nuts.

## 6.6 CONDENSER FAN MOTOR (AIR-COOLED ONLY)

### A. FAN MOTOR REPLACEMENT

1. Disconnect machine from electrical supply before removing any panels for servicing.
2. Remove the panels and the header panel as noted below.  
E112-LJ: Remove both side panels  
F112-LJ: Remove the left side panel and rear panel

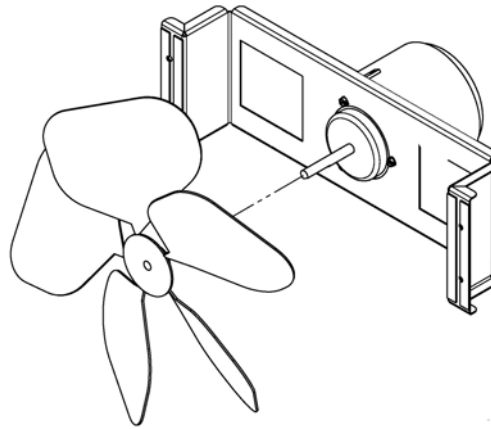


Figure 6.6 Fan Motor Replacement

Trace and disconnect the wires on the T1 and T2 terminals on the compressor contactor. The F112 has a black and white wire connected to the contactor. The E112 has two black wires.

Remove the four screws on the fan motor bracket and remove the bracket. Be careful to not damage the fins on the condenser when removing the fan.

Loosen set screw on fan blade.

Remove the three bolts from the fan motor mounting plate and remove the motor.

### B. FAN MOTOR INSTALLATION

5. Route the wires to the compressor contactor.
6. Connect the wires to the contactor as follows:  
F112-LJ: Connect black wire to the T1 terminal. Connect white wire to the T2 terminal.  
E112-LJ: Connect a black wire to the T1 terminal and connect the other black wire to the T2 terminal. It does not matter which wire is connected to which terminal.
3. For F112-LJ only: Ensure the purple wire is terminated. and the ensure red wire is terminated with blue wire.
1. Attach motor to the mounting plate with the three bolts.
2. Place fan blade on motor shaft. Make sure the motor shaft does not extend past the hub of the fan blade.
7. Install the fan motor bracket to the condenser.
8. Position the fan on the motor shaft so that the blades are 3/8" from the fins on the condenser. Tighten the set screw.

## 6.7 SWITCHES

### A. SPIGOT SWITCH

The spigot switch is a normally closed, held open switch. When a spigot is pulled, the spigot switch sends a signal to the control board to start the drive motor.

#### SPIGOT SWITCH TESTING - ELECTRICAL

1. Disconnect the switch from the circuit by unplugging the connector.
2. Check resistance readings across the common (COM) and normally closed (NC) terminals. When the spigot is closed (not dispensing), the resistance should show an open. When the spigot is opened (during dispensing), the switch will close and the resistance should be 0 ohms.

#### SPIGOT SWITCH REPLACEMENT

1. Remove the header panel.
2. Disconnect the connector from the switch and remove the switch.
3. Install the replacement switch onto the spigot assembly.
4. Attach the connector to the spigot switch.
5. Replace the header panel and secure with the two Phillips head screws.

### B. TORQUE SWITCH

The torque switch is a normally open switch. During the freezing cycle, the product in the freezing cylinder increases consistency. As product consistency increases, the stator bar rotates and moves the torque rod. When the torque rod activates the torque switch, the product in the freezing cylinder is at consistency.

#### TORQUE SWITCH TEST

1. Disconnect the switch from the circuit by unplugging the connector.
2. Check resistance readings across the common (COM) and normally open (NO) terminals. When the switch is open, the resistance should show an open. When the switch is closed, the resistance should be 0 ohms.

#### TORQUE SWITCH REPLACEMENT

1. Remove the header panel.
2. Disconnect the connector from the switch and remove the switch.
3. Install the replacement switch onto the torque assembly.
4. Attach the connector to the torque switch.
5. Replace the header panel and secure with the two Phillips head screws.

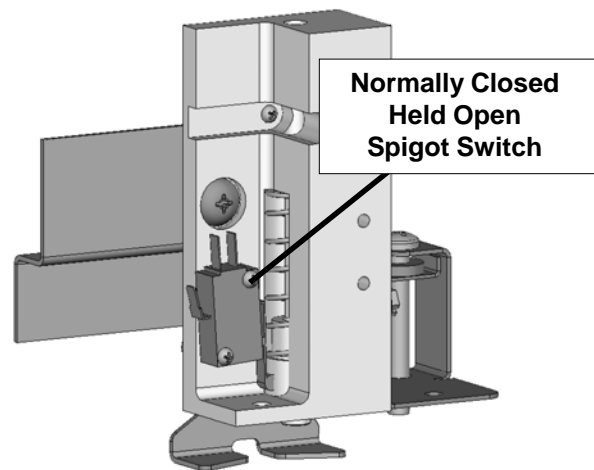


Figure 6-7 Spigot Switch

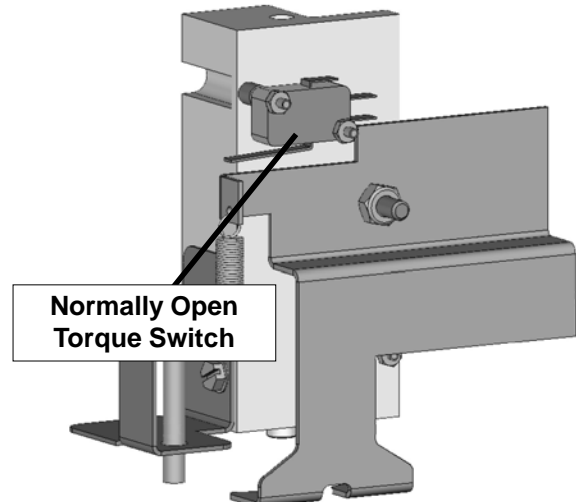


Figure 6-8 Torque Switch



## SECTION 7 TROUBLESHOOTING

### 7.1 LIGHT INDICATORS

The machine has two lights that will alert the user if a problem occurs: an ADD MIX light and a Diagnostic Light. The ADD MIX light will flash to alert the operator to a low mix condition. It does so by monitoring the mix level in the hopper. When the ADD MIX light is flashing, refill hopper immediately. The Diagnostic Light will flash if an error occurs. Refer to the chart below for details.

Indication	On	One Blink	Two Blinks	Three Blinks
<b>Conditions</b>	Defrost Mode	Torque is not met after 22 minutes	Drive current is not sensed	Machine left in clean mode for over 20 minutes
<b>Self Correction</b>	N/A	N/A	The machine attempts to sense drive current with a 3 second pre-stir. If current is sensed, the machine will return to normal operation. If current is not sensed, the machine will wait 7 minutes and try to sense current with another 3 second pre-stir. After the third attempt, the compressor will run on timers.	N/A
<b>Operation</b>	Every 7 minutes the auger will run for 90 seconds.	Timers or until torque switch remains closed for 3 seconds.	Timers	Off
<b>Corrective Action</b>	End Defrost Mode by turning Clean/Off/On switch OFF then turning it back ON. Opening the spigot will also end Defrost Mode.	Check for product in the hopper, check if the condenser is dirty, check the refrigeration system.	Check that there is power going to the contactor, check for power leaving the contactor, check for power at the motor.	Turn Clean/Off/On switch OFF then turn it back ON.

### 7.2 TROUBLESHOOTING - MACHINE

PROBLEM	POSSIBLE CAUSE	REMEDY
<b>Machine does not run.</b>	<ol style="list-style-type: none"> <li>1 Power to machine is off.</li> <li>2 Blown fuse or tripped circuit.</li> <li>3 Freeze-up (auger will not turn).</li> <li>4 Front door not in place.</li> </ol>	<ol style="list-style-type: none"> <li>1 Supply power to machine.</li> <li>2 Replace or reset.</li> <li>3 Turn Clean/Off/On switch Off for 15 minutes, then restart.</li> <li>4 Assemble front door in place.</li> </ol>
<b>Machine will not shut off before 22 minute Compressor Time Out Mode.</b>	<ol style="list-style-type: none"> <li>1 Drive belt failure.</li> <li>2 Consistency temperature setting is too firm.</li> <li>3 Refrigeration problem.</li> </ol>	<ol style="list-style-type: none"> <li>1 Replace drive belt.</li> <li>2 Turn Consistency Adjustment knob counter-clockwise.</li> <li>3 Check system. (Call distributor for service)</li> </ol>
<b>Product is too firm.</b>	<ol style="list-style-type: none"> <li>1 Consistency temperature setting is too firm.</li> </ol>	<ol style="list-style-type: none"> <li>1 Turn Consistency Adjustment knob counter-clockwise.</li> </ol>

## 7.2 TROUBLESHOOTING - MACHINE - CONTINUED

PROBLEM	POSSIBLE CAUSE	REMEDY
<b>Product is too thin.</b>	<ol style="list-style-type: none"> <li>1 No vent space for free flow of cooling air.</li> <li>2 Condenser is dirty.</li> <li>3 Consistency setting too soft.</li> <li>4 Auger is assembled incorrectly.</li> <li>5 Auto Fill Pump not operating.</li> <li>6 Refrigeration problem.</li> </ol>	<ol style="list-style-type: none"> <li>1 A minimum of 6" of air space on both sides (the E112 requires 3"). (See Section 2)</li> <li>2 Clean. (See Section 3)</li> <li>3 Turn Consistency Adjustment knob clockwise.</li> <li>4 Remove mix, clean, reassemble, sanitize and freeze down.</li> <li>5 See Auto Fill Troubleshooting section.</li> <li>6 Check system. (Call distributor for service)</li> </ol>
<b>Product does not dispense.</b>	<ol style="list-style-type: none"> <li>1 No mix in hopper.</li> <li>2 Drive motor overload tripped.</li> <li>3 Drive belt failure.</li> <li>4 Freeze-up (Auger will not turn).</li> </ol>	<ol style="list-style-type: none"> <li>1 See Auto Fill Troubleshooting section.</li> <li>2 Wait for automatic reset. (If condition continues, call distributor for service.)</li> <li>3 Replace drive belt.</li> <li>4 Turn Clean/Off/On switch Off for 15 minutes, then restart.</li> </ol>
<b>Drive belt slipping or squealing.</b>	<ol style="list-style-type: none"> <li>1 Worn drive belt.</li> <li>2 Freeze-up (Auger will not turn).</li> <li>3 Not tensioned properly.</li> </ol>	<ol style="list-style-type: none"> <li>1 Replace drive belt.</li> <li>2 Turn Clean/Off/On switch Off for 15 minutes, then restart.</li> <li>3 Adjust belt tension</li> </ol>
<b>Rear auger seal leaks.</b>	<ol style="list-style-type: none"> <li>1 Outside surface of rear auger seal is lubricated.</li> <li>2 Rear seal missing or damaged.</li> <li>3 Seal o-ring missing, damaged or installed incorrectly.</li> <li>4 Worn or scratched auger shaft.</li> </ol>	<ol style="list-style-type: none"> <li>1 Clean lubricant from outside of rear seal, lubricate inside of seal and reinstall.</li> <li>2 Check or replace.</li> <li>3 Check. or replace.</li> <li>4 Replace auger shaft.</li> </ol>
<b>Front door leaks.</b>	<ol style="list-style-type: none"> <li>1 Front door knobs are loose.</li> <li>2 Spigot parts are not lubricated.</li> <li>3 Chipped or worn spigot o-rings.</li> <li>4 O-rings or spigot installed wrong.</li> <li>5 Inner spigot hole in front door nicked or scratched.</li> </ol>	<ol style="list-style-type: none"> <li>1 Tighten knobs.</li> <li>2 See Section 3.</li> <li>3 Replace o-rings.</li> <li>4 Remove spigot and check o-ring.</li> <li>5 Replace front door.</li> </ol>

## 7.3 TROUBLESHOOTING - AUTO FILL SYSTEM

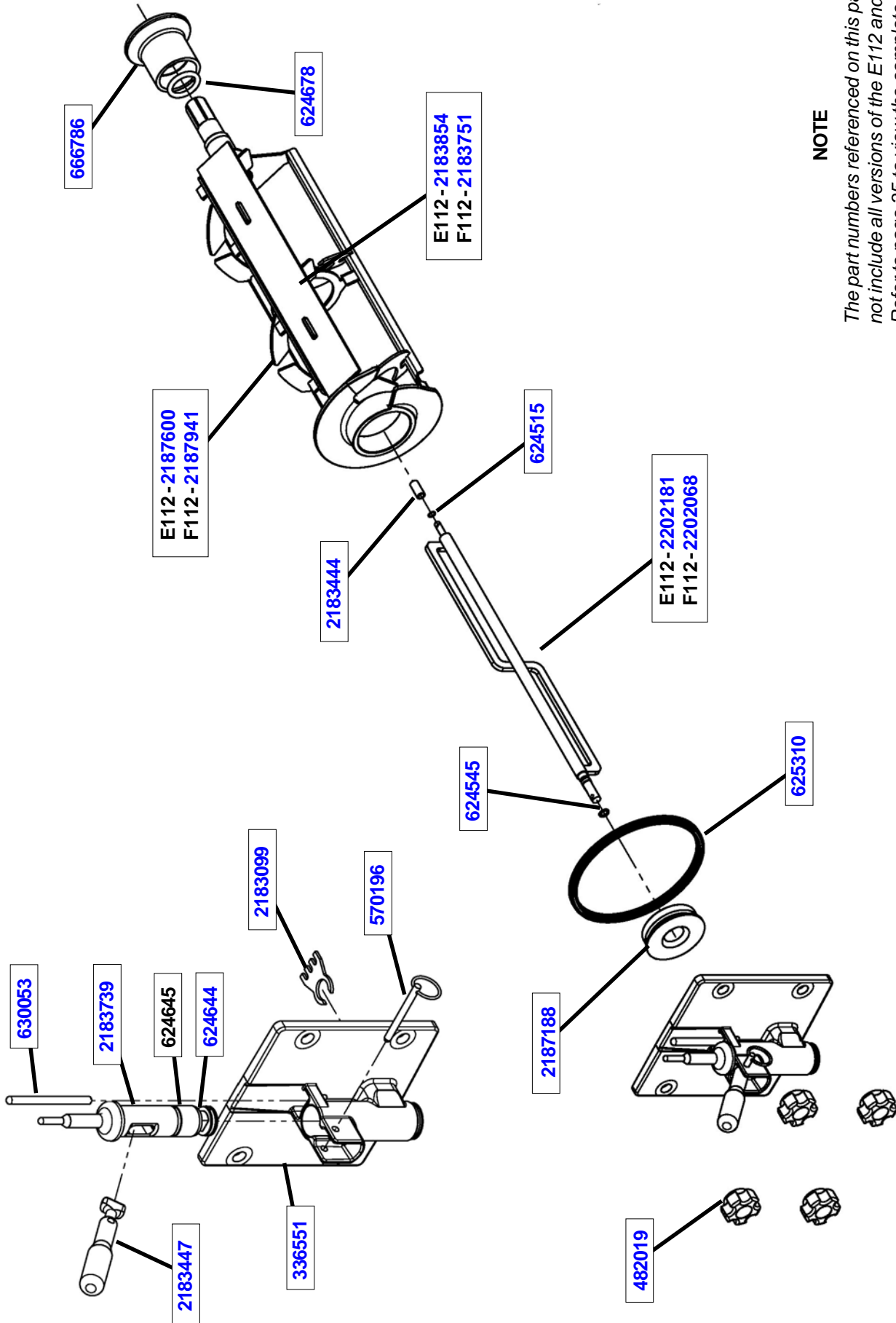
PROBLEM	POSSIBLE CAUSE	REMEDY
<b>Pump does not operate.</b>	<ol style="list-style-type: none"> <li>1 Low water pressure.</li> <li>2 Restriction or plugged auto fill system.</li> <li>3 Empty BIB</li> </ol>	<ol style="list-style-type: none"> <li>1 Verify that there is adequate water pressure at the inlet fitting (30-50 psi).</li> <li>2 Flush and sanitize the pump and tubing.</li> <li>3 Replace BIB</li> </ol>
<b>Syrup concentration incorrect</b>	<ol style="list-style-type: none"> <li>1 BIB connector is not connected to the BIB properly.</li> <li>2 Leak at the connections or in the tubing.</li> <li>3 Air in the BIB syrup container.</li> <li>4 Pump is clogged with debris or particulates.</li> </ol>	<ol style="list-style-type: none"> <li>1 Check connection and reconnect if necessary.</li> <li>2 Look for leaks at the connections and bubbles in the tubing. Tighten clamps and replace tubing if necessary.</li> <li>3 Remove the air from the BIB syrup container.</li> <li>4 Remove syrup valves and inspect for debris or improper closing that would interfere with operation.</li> </ol>

## SECTION 8 REPLACEMENT PARTS

### 8.1 DECALS, LUBRICATION, PANELS & LEGS

Part	Description	Quantity	
		E112-LJ	F112-LJ
208135	Brush - 4" X 8" X 16" (Barrel)	1	1
208380	Brush - 1/4" X 3" X 14"	1	1
208401	Brush - 1" X 3" X 10"	1	1
232091	Cap - Protective (Gray) - #490716 Leg		1
236054	Card - Cleaning Auto Fill Pump Kit	1	1
236060	Card - Cleaning Instruction	1	1
324105	Decal - Caution Electrical Shock	1	1
324106	Decal - Caution Electrical Wiring Materials	1	1
324107	Decal - Caution Hazardous Moving Parts	1	1
324141	Decal - Caution Rotating Blades	1	1
324208	Decal - Attention Refrigerant Leak Check	1	1
324393	Decal - Stoelting Swirl Logo	1	1
324509	Decal - Cleaning Instructions	1	1
324548	Decal - Adequate Ventilation 6"		1
324566	Decal - Wired According To	1	1
324584	Decal - Adequate Ventilation 3"	1	
324686	Decal - Danger Automatic Start	1	1
324804	Decal - Domed Stoelting Swirl (Header Panel)	1	1
324852	Decal - Clean Condenser Filter	1	
324865	Decal - Standby Light	1	1
396244	Gasket - Freezer Base		1
430165	Cord - Power	1	
430172	Cord - Power		1
490716	Leg		4
490749	Leg - Front	2	
490750	Leg - Rear (w/Suction Cup)	2	
508048	Lubricant - Spline (2 oz Squeeze Tube)	1	1
508135	Petrol Gel - 4 oz Tube	1	1
513643	Manual - Owner's	1	1
649105	Screw - Self-Tapping (E112 - Side Panels) (F112 - All Panels)	-	-
1183955	O-Ring Kit	-	-
2183639	Panel - L.H. Side	1	
2183640	Panel - R.H. Side	1	
2183704	Panel - Header		1
2183710	Panel - Bottom		1
2183782	Panel - Header	1	
2183783	Panel - Front	1	
2183808	Panel - Rear	1	
2187029	Panel - R.H. Side		1
2187030	Panel - L.H. Side		1
2187036	Panel - Front		1
2187197	Panel - Rear		1
2202232	Panel - Rear Cover-Up		1

## 8.2 AUGER SHAFT AND FACEPLATE PARTS



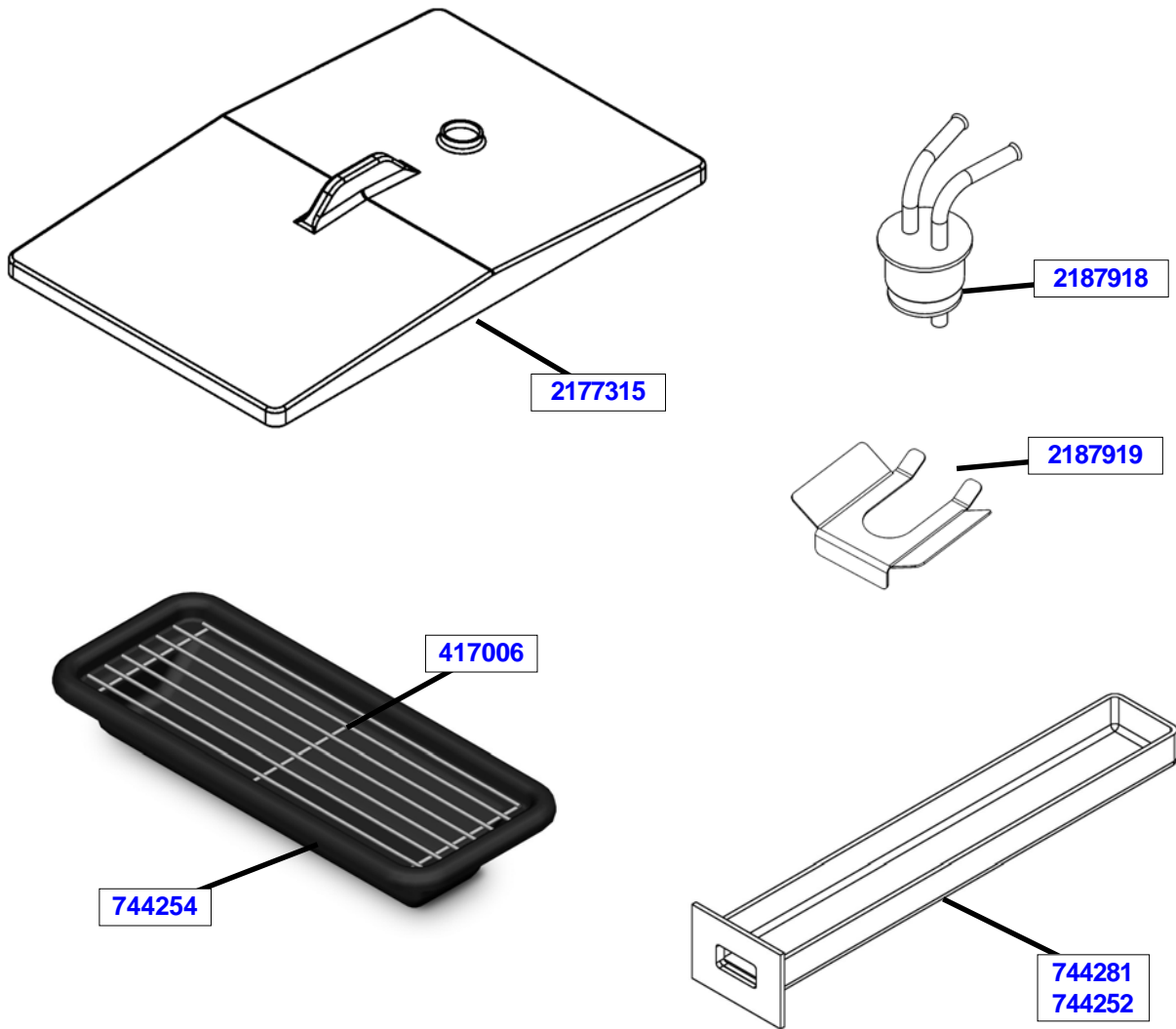
### NOTE

The part numbers referenced on this page do not include all versions of the E112 and F112. Refer to page 35 to view the complete listing.

## 8.2 AUGER SHAFT AND FACEPLATE PARTS - CONTINUED

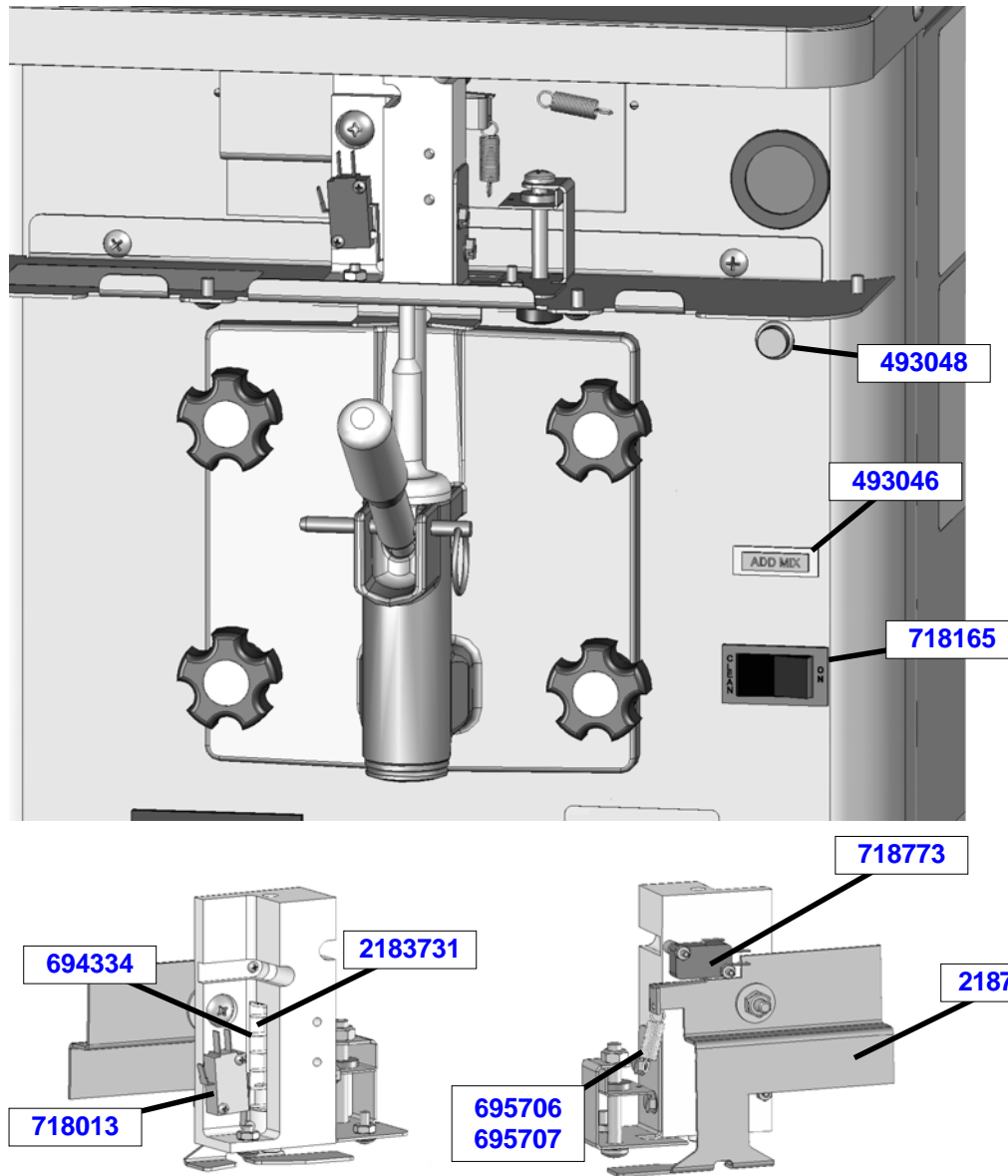
Part	Description	Quantity	
		E112-LJ	F112-LJ
336551	Door - Front	1	1
482019	Knob - Front Door (Black)	4	4
570196	Pin - Cotterless Clevis (Front Door)	1	1
624515-5	O-Ring - Stator Bar Rear (5 Pack)	1	1
624545-5	O-Ring - Stator Bar Front (5 Pack)	1	1
624644-5	O-Ring - Spigot Body (Bottom) (5 Pack)	1	1
624645-5	O-Ring - Spigot Body (Top) (5 Pack)	1	1
624678-5	O-Ring - Rear Seal - Black (5 Pack)	1	1
625310	Quad-Ring - Front Door - Black	1	1
630053	Rod - Torque Actuator	1	1
666786	Seal - Rear Auger - Black	1	1
2183099	Breaker Bar - Spigot Body	1	1
2183444	Bushing - Stator Support (Rear)	1	1
2183447	Handle Only - Spigot	1	1
2183739	Spigot Body	1	1
2183751	Blade - Scraper		1
2183854	Blade - Scraper	1	
2187188	Bushing - Front Auger Support	1	1
2187600	Auger Shaft	1	
2187941	Auger Shaft		1
2202068	Stator Bar		1
2202181	Stator Bar	1	

### 8.3 HOPPER PARTS



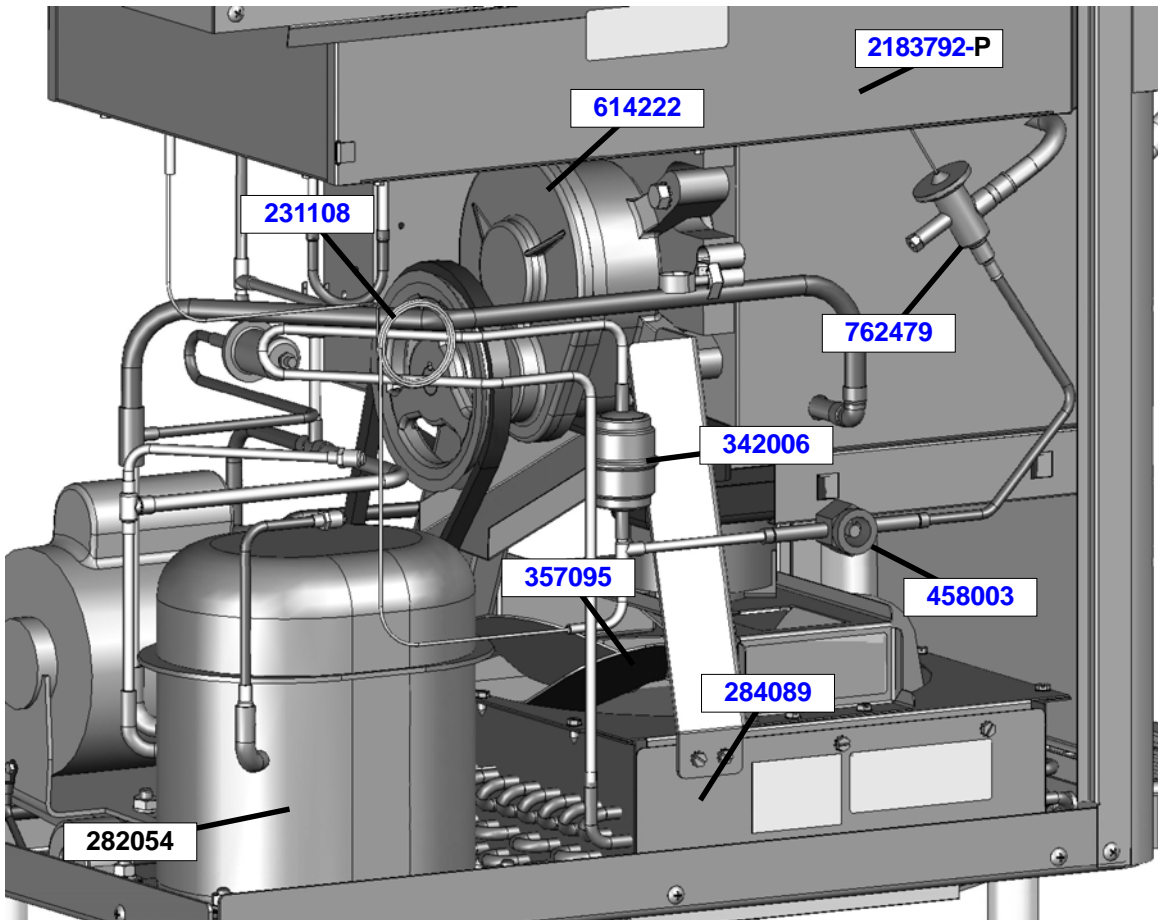
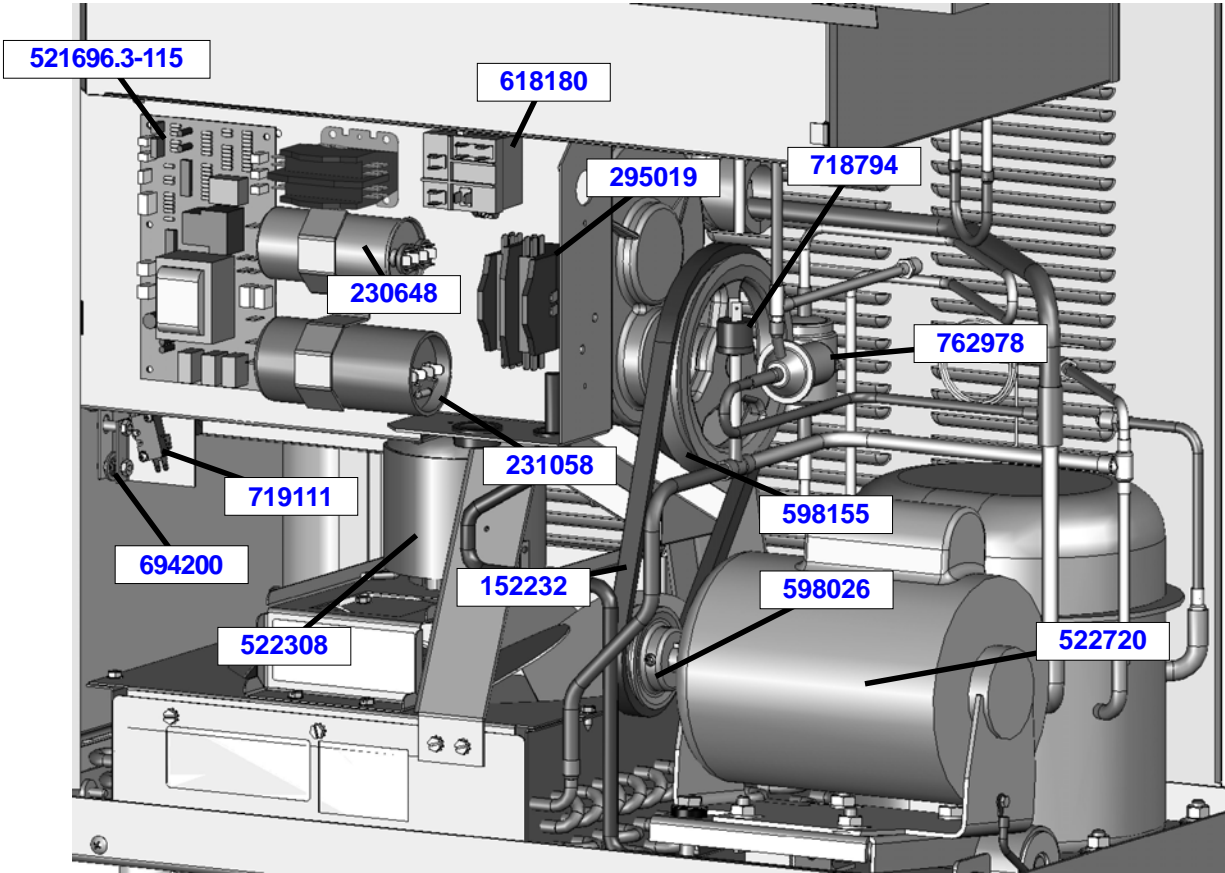
Part	Description	Quantity	
		E112-LJ	F112-LJ
376086	Hose Adapter (1/4" x 3/8")	2	2
417006	Grid - Drip Tray (Metal)	1	1
744252	Tray - Drain (Front) (18 3/8" Long)	-	-
744254	Tray - Drip	1	1
744281	Tray - Drain (Front) (12 3/4" Long)	1	1
2177315	Cover - Hopper	1	1
2187918	Mix Inlet Assembly	1	1
2187919	Clip - Retaining (Mix Inlet)	1	1

## 8.4 MACHINE FRONT & SPIGOT SWITCH ASSEMBLY



Part	Description	Quantity	
		E112-LJ	F112-LJ
493046	Light - Mix Low	1	1
493048	Light - Diagnostic (Round)	1	1
694334	Spring - Compression (Spigot Switch)	1	1
695706	Spring - Consistency Adjustment (Green)	1	
695707	Spring - Consistency Adjustment (Yellow)		1
718013	Switch - Roller (Spigot)	1	1
718165	Switch - Rocker (Clean-Off-On)	1	1
718773	Switch - Limit (Torque Consistency)	1	1
2183731	Actuator - Spigot Switch	1	1
2183851	Bracket - Drip Tray	1	1
2187792	Bracket - Torque Switch	1	1

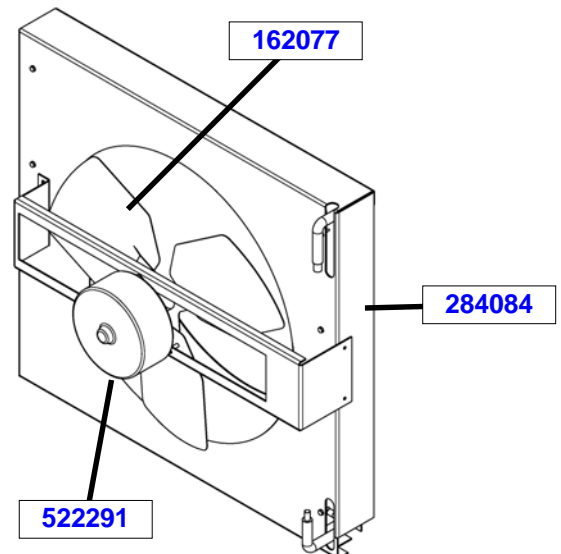
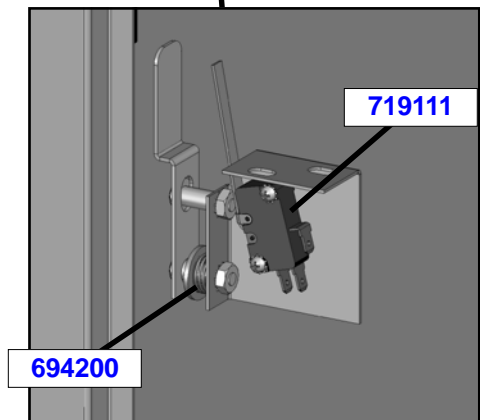
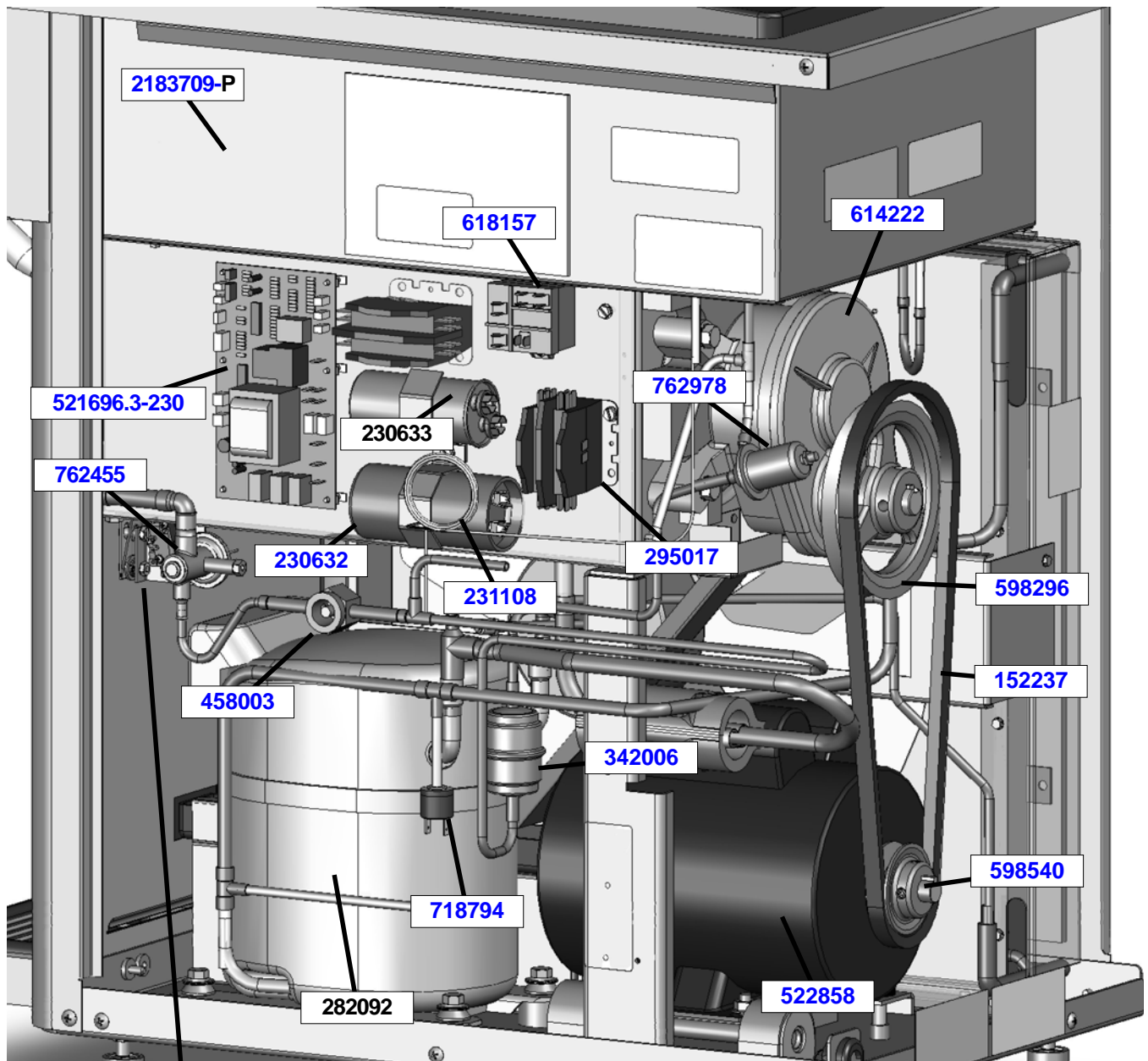
# 8.5 E112-LJ PARTS



## 8.5 E112-LJ PARTS - CONTINUED

Part	Description	E112-LJ Quantity
152232	Belt - Grip-Notch (AX26)	1
230648	Capacitor - Run (Compressor)	1
231058	Capacitor - Start (Compressor)	1
231108	Cap Tube Only	1
266196	Pin - Parts Safety	1
282054	Compressor (No Capacitors)	1
284089	Condenser - Air-Cooled	1
295019	Contactora (45CG20AF)	1
342006	Drier	1
357095	Blade - Fan (Air-Cooled Condenser)	1
368397	Filter (2 Required)	2
458003	Indicator - Liquid Line	1
521696.3-115	Program Control Board	1
522308	Fan Motor - Condenser	1
522720	Motor - Drive - 1/3 HP	1
598026	Pulley - Drive Motor	1
598155	Pulley - Speed Reducer	1
614222	Speed Reducer	1
618180	Relay (Compressor)	1
694200	Spring - Door Interlock	1
718794	Switch - High Pressure Reset	1
719111	Switch - Limit (Door Interlock)	1
756067	Tubing - 1/4" ID (Per Inch) (Auto Fill Kit)	-
762479	Valve - Expansion	1
762978	Valve - EPR	1
763664	Valve - Solenoid (Auto Fill Kit)	-
2183792-P	Evaporator Assembly	1

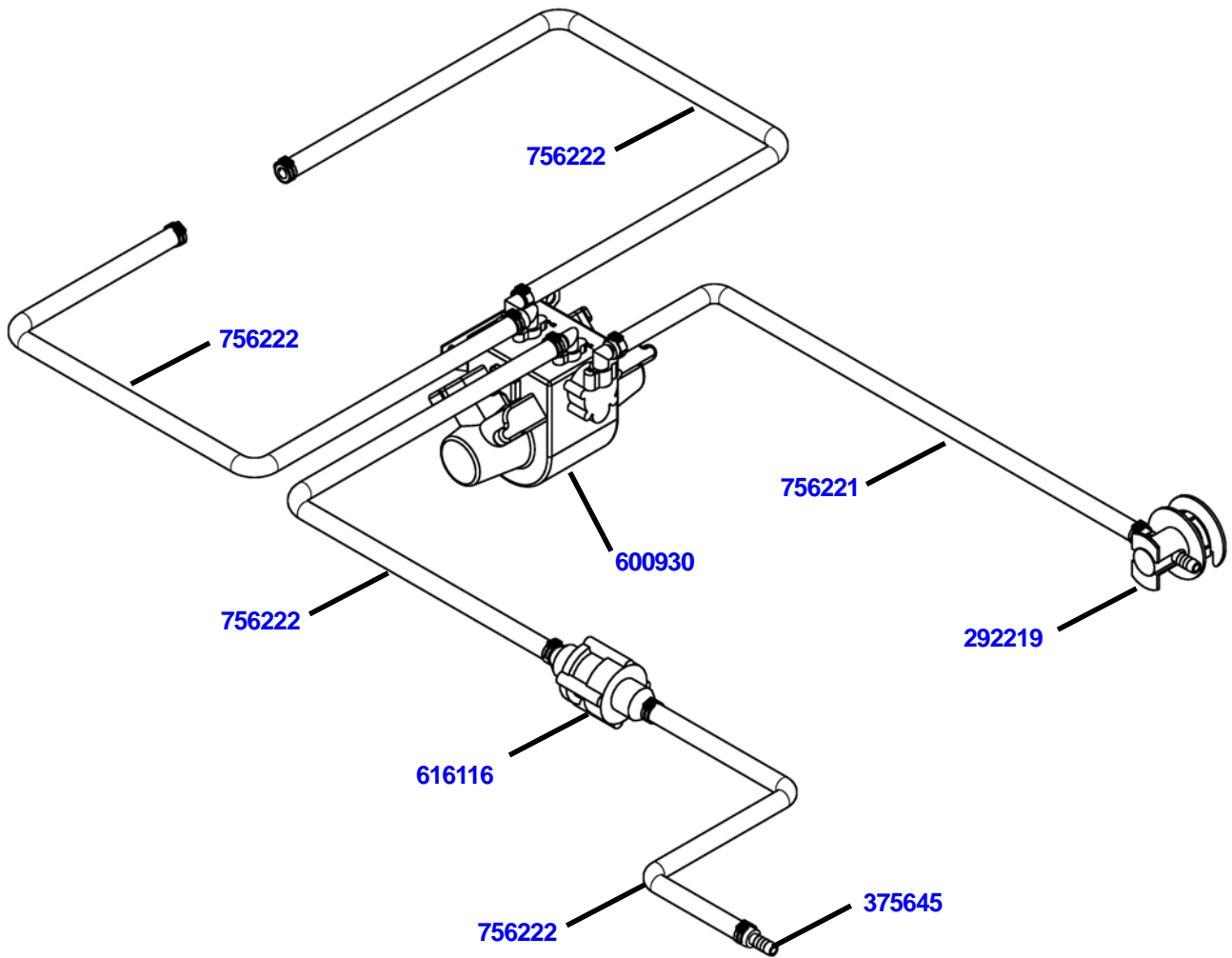
8.6 F112-LJ PARTS



## 8.6 F112-LJ PARTS - CONTINUED

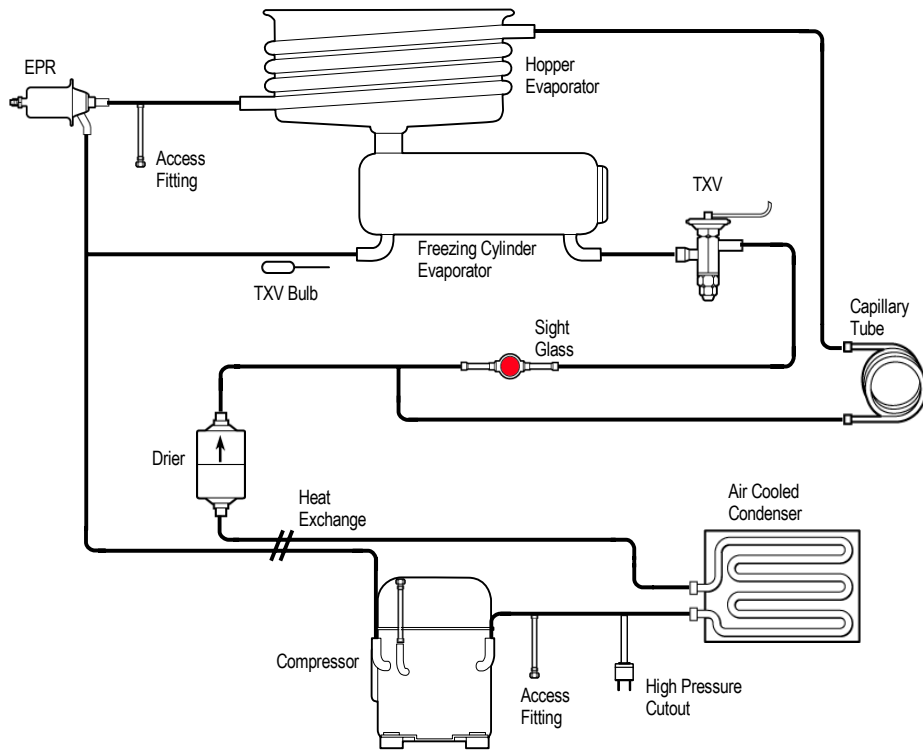
Part	Description	F112-LJ Quantity
152237	Belt - Grip-Notch (AX35)	1
162077	Blade - Fan (Air-Cooled Condenser)	1
230632	Capacitor - Start (#282045 or #282092 Compressors)	1
230633	Capacitor - Run (#282045 or #282092 Compressors)	1
231078	Capacitor - Run (# 522858 Motor)	1
231095	Capacitor - Start (#522858 Motor)	1
231108	Cap Tube Only	1
264235	Clamp - Metal (1/4" I.D. Tubing) (Auto Fill Kit)	-
282092	Compressor - 60 Hz - R404A (No Capacitors)	1
284084	Condenser (Air-Cooled)	1
295017	Contactora (45CG20AG)	1
342006	Drier	1
368140	Filter - Air (Condenser)	1
458003	Indicator - Liquid Line	1
521696.3-230	Program Control Board	1
522291	Motor - Fan	1
522858	Motor - Drive	1
598296	Pulley - Speed Reducer	1
598540	Pulley - Drive Motor	1
614222	Speed Reducer	1
618157	Relay - Start (#282045 or #282092 Compressors)	1
694200	Spring - Door Interlock	1
718794	Switch - High Pressure Reset	1
719111	Switch - Limit (Door Interlock)	1
744142	Transformer (Auto Fill Kit)	-
756067	Tubing - 1/4" ID (Auto Fill Kit)	-
762455	Valve - Expansion	1
762978	Valve - EPR	1
763458	Valve - Solenoid (Auto Fill Kit)	-
2183709-P	Evaporator Assembly	1

## 8.7 AUTO FILL PARTS

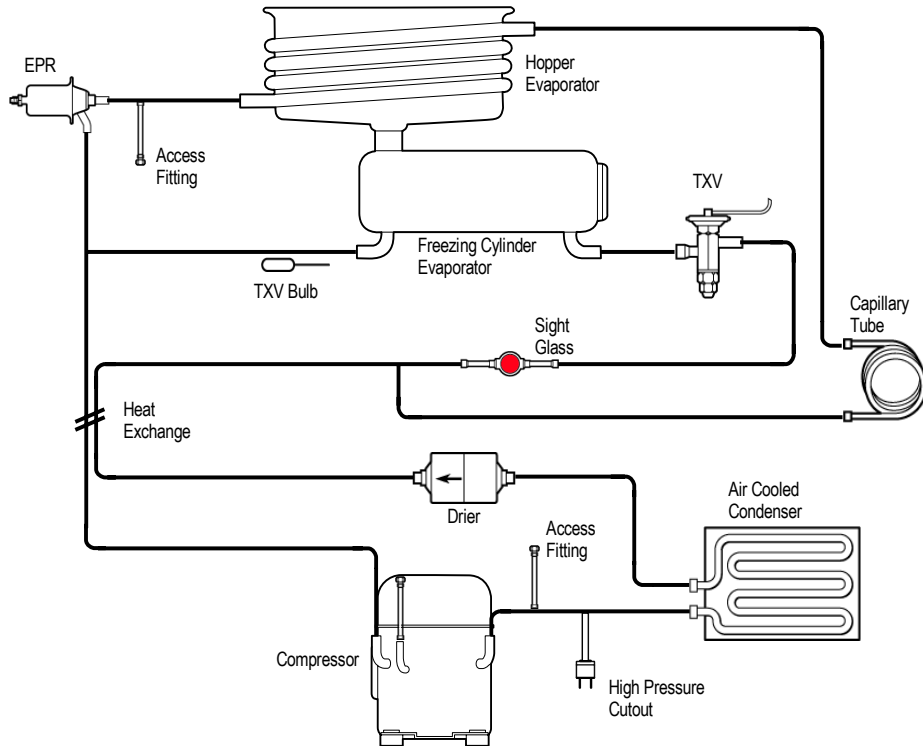


Part	Description	Quantity
264100	Clamp - Oetiker Stepless #17	2
264101	Clamp - Oetiker Stepless #15.7	23
292219	Connector - Bag In Box	1
375645	Fitting - 3/8" x 3/8"	1
538463	Nut	2
600930	Pump - Brix	1
616116	Water Regulator	1
644359	Screw - 10-32 x 1/2"	2
739126	Tie Wrap - 15"	10
739127	Tie Wrap - 7"	2
756221	Tubing - 3/8" Clear	3'
756222	Tubing - 3/8" Braided	40'

## 8.8 REFRIGERATION DIAGRAM

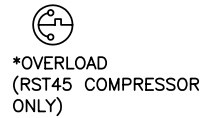
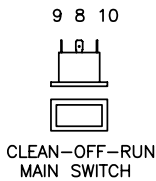
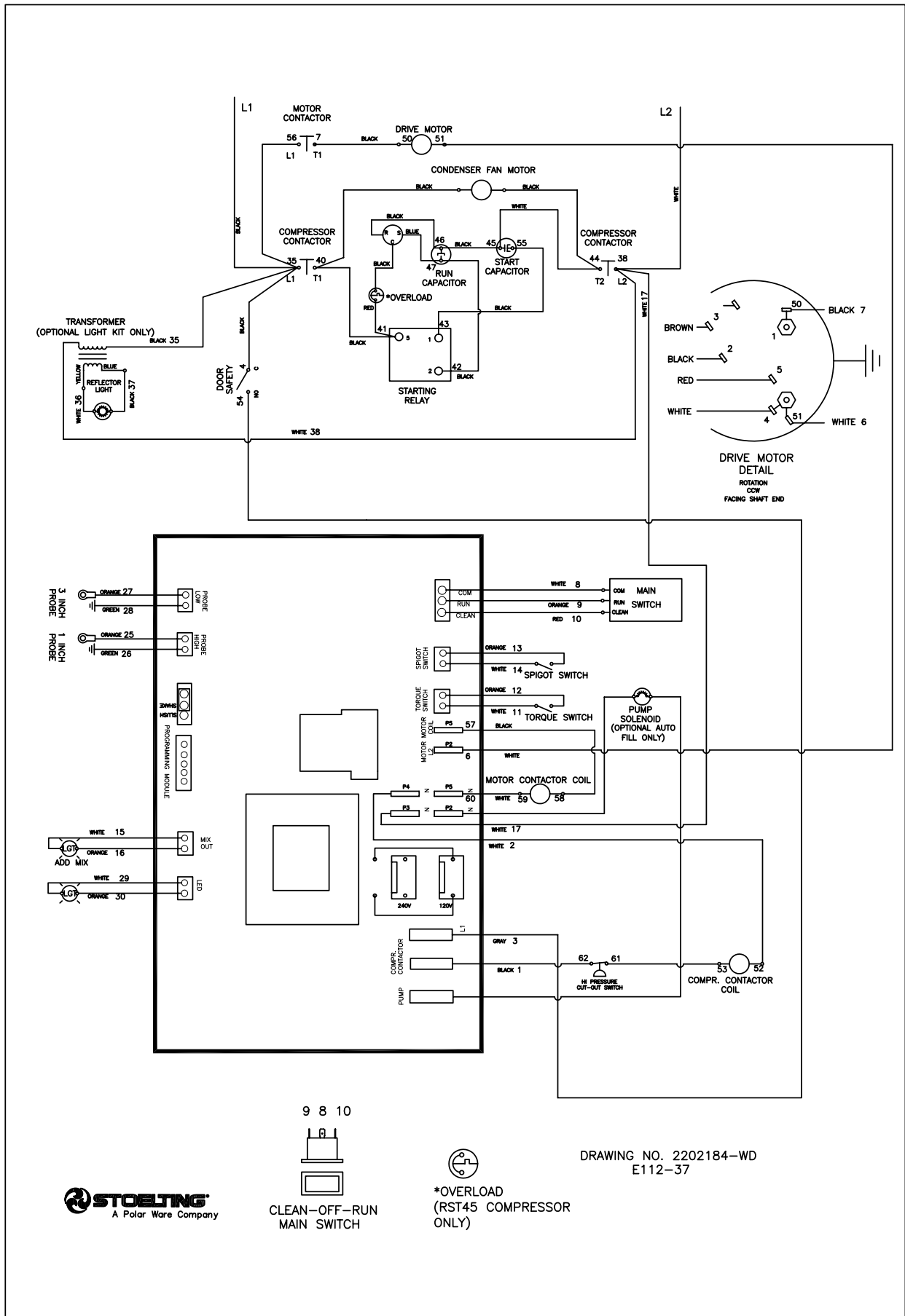


**E112-LJ Refrigeration Diagram**



**F112-LJ Refrigeration Diagram**

# 8.9 E112-LJ WIRING DIAGRAM



DRAWING NO. 2202184-WD  
E112-37

# 8.10 F112-LJ WIRING DIAGRAM

