

INSTALLATION AND SERVICE MANUAL

INDOOR GAS-FIRED DUCT FURNACE (POWER VENTED)

ATTENTION: READ THIS MANUAL AND ALL LABELS ATTACHED TO THE UNIT CAREFULLY BEFORE ATTEMPTING TO INSTALL, OPERATE OR SERVICE THESE UNITS! CHECK UNIT DATA PLATE FOR TYPE OF GAS AND ELECTRICAL SPECIFICATIONS AND MAKE CERTAIN THAT THESE AGREE WITH THOSE AT THE POINT OF INSTALLATION. RECORD THE UNIT MODEL AND SERIAL No.(s) IN THE SPACE PROVIDED. RETAIN FOR FUTURE REFERENCE.

Model No. _____ Serial No. _____

FOR YOUR SAFETY

The use and storage of gasoline or other flammable vapors and liquids in open containers in the vicinity of this appliance is hazardous.

FOR YOUR SAFETY

If you smell gas:

1. Open windows.
2. Don't touch electrical switches.
3. Extinguish any open flame.
4. Immediately contact your gas supplier.



▲ WARNING Improper installation, adjustment, alteration, service, or maintenance can cause property damage, injury, or death. Read the installation, operating, and maintenance instruction thoroughly before installing or servicing this equipment.

APPROVED FOR USE IN CALIFORNIA WHEN EQUIPPED WITH INTERMITTENT PILOT IGNITION

▲ WARNING Install, operate, and maintain unit in accordance with the manufacturer's instructions to avoid exposure to fuel substances, or substances from incomplete combustion, which can cause death or serious illness. The state of California has determined that these substances may cause cancer, birth defects, or other reproductive harm.

INSTALLER'S RESPONSIBILITY

Installer Please Note: This equipment has been test fired and inspected. It has been shipped free from defects from our factory. However, shipment and installation problems such as loose wires, leaks, or loose fasteners may occur. **It is the installer's responsibility to inspect and correct any problem that may be found.**

RECEIVING INSTRUCTIONS

Inspect shipment immediately when received to determine if any damage has occurred to the unit during shipment. After the unit has been uncrated, check for any visible damage to the unit. If any damage is found, the consignee should sign the bill of lading indicating such damage and immediately file claim for damage with the transportation company.

Look in direction of air flow to determine if your unit is right or left hand accessible.



MESTEK, INC.

260 NORTH ELM ST., WESTFIELD, MA 01085

TEL: (413) 564-5540 FAX: (413) 562-5311

www.mestek.com



MODEL TYPE DESIGNATION

Figure 1 = Power Vented Duct Furnace (Bottom Access, Rear Vent Position, Intermittent Pilot Ignition)

Figure 2 = Side Service Power Vented Duct Furnace (Side Access, Rear Vent Position, Intermittent Pilot Ignition)

TABLE OF CONTENTS

GENERAL SAFETY INFORMATION	2, 3
DUCT FURNACES (POWER VENTED)	
SPECIFICATIONS.....	4
PERFORMANCE DATA.....	5
INSTALLATION	
Location, Clearances.....	6
Ductwork, Air Flow, Ventilation, Bypass.....	7
Suspension.....	8
Electrical Connections.....	9
Venting.....	10 - 15
Gas Piping.....	16
Pipe Installation.....	17
OPERATION	
Power Vented Units with Intermittent Pilot.....	18 - 20
Orifice Sizing.....	20
Adjustments.....	20, 21
MAINTENANCE	21
COMPONENT PARTS	22, 23, 24
TROUBLESHOOTING CHART	25 - 28
REPLACEMENT PARTS	29
WARRANTY	29
UNIT NUMBER DESCRIPTION	30
START-UP/INSPECTION SHEET	32

GENERAL SAFETY INFORMATION

The duct furnace design is certified by ETL for use with natural and LP (propane) gases. ANSI and NFPA Standards as well as Canadian installation codes referred to in this manual are the ones that were applicable at the time the design was certified.

If the unit is to be installed at an altitude exceeding 2,000 feet (610m) above sea level, derate the input by 4% for each 1,000 foot (305m) rise above sea level. Special orifices are required for installations above 2,000 feet (610m).

When units are installed in Canada, any reference to derations at altitudes in excess of 2000 feet (610m) are to be ignored. At altitudes of 2000 to 4500 feet (610 to 1372m), the units must be orificed to 90% of the normal altitude rating, and be so marked in accordance with ETL certification.

The following terms are used throughout this manual, in addition to ETL requirements, to bring attention to the presence of potential hazards or to important information concerning the product:

▲ DANGER Indicates an imminently hazardous situation which, if not avoided, will result in death, serious injury or substantial property damage.

▲ WARNING Indicates an imminently hazardous situation which, if not avoided, could result in death, serious injury or substantial property damage.

▲ CAUTION Indicates an imminently hazardous situation which, if not avoided, may result in minor injury or property damage.

NOTICE: Used to notify of special instructions on installation, operation or maintenance which are important to equipment but not related to personal injury hazards.

GENERAL SAFETY INFORMATION

▲ WARNING Failure to comply with the general safety information may result in extensive property damage, severe personal injury or death.

▲ WARNING This product must be installed by a licensed plumber or gas fitter when installed within the Commonwealth of Massachusetts.

Installation must be made in accordance with local codes, or in absence of local codes, with the latest edition of ANSI Standard Z223.1 (N.F.P.A. No. 54) National Fuel Gas Code. All of the ANSI and NFPA Standards referred to in these installation instructions are those that were applicable at the time the design of this appliance was certified. The ANSI Standards are available from the CSA Information Services, 1-800-463-6727. The NFPA Standards are available from the National Fire Protection Association, Batterymarch Park, Quincy, MA 02269. These duct furnaces are designed for use in airplane hangars when installed in accordance with current ANSI/NFPA No. 409 and in public garages when installed in accordance with current NFPA No. 88A and NFPA No. 88B.

If installed in Canada, the installation must conform with local building codes, or in absence of local building codes, with CSA-B149.1 "Installation Codes for Natural Gas Burning Appliances and Equipment" or CSA-B149.8 "Installation Codes for Propane Gas Burning Appliances and Equipment". These indoor duct furnaces have been designed and certified to comply with CSA 2.6. Also see sections on installation in AIRCRAFT HANGARS and PUBLIC GARAGES.

▲ WARNING Do not alter the duct furnace in any way or damage to the unit and/or severe personal injury or death may occur!

▲ WARNING Disconnect all power and gas supplies before installing or servicing the heater. If the power disconnect is out of sight, lock it in the open position and tag it to prevent unexpected application of power. Failure to do so could result in fatal electric shock, or severe personal injury.

▲ CAUTION Insure that all power sources conform to the requirements of the unit heater or damage to the unit will result!

Follow installation instructions CAREFULLY to avoid creating unsafe conditions. All wiring should be done and checked by a qualified electrician, using copper wire only. All external wiring must conform to applicable local codes, and to the latest edition of the National Electric Code ANSI/NFPA No. 70. All gas connections should be made and leak-tested by a suitably qualified individual, per instructions in this manual.

Also follow procedures listed on the "Gas Equipment Start-up" sheet located in this manual.

Use only the fuel for which the heater is designed (see rating plate). Using LP gas in a heater that requires natural gas, or vice versa, will create the risk of gas leaks, carbon monoxide poisoning and explosion.

▲ WARNING Do not attempt to convert the heater for use with a fuel other than the one intended. Such conversion is dangerous, and could create unsafe conditions that result in death, serious personal injury or property damage.

Make certain that the power source conforms to the electrical requirements of the heater.

▲ WARNING Do not depend upon a thermostat or other switch as sole means of disconnecting power when installing or servicing heater. Always disconnect power at main circuit breaker as described above. Failure to do so could result in fatal electric shock.

Special attention must be given to any grounding information pertaining to this heater. To prevent the risk of electrocution, the heater must be securely and adequately grounded. This should be accomplished by connecting a grounded conductor between the service panel and the heater. To ensure a proper ground, the grounding means must be tested by a qualified electrician.

Do not insert fingers or foreign objects into the heater or its air moving device. Do not block or tamper with the heater in any manner while in operation or just after it has been turned off, as some parts may be hot enough to cause injury.

This heater is intended for general heating applications ONLY. It must NOT be used in potentially dangerous locations such as flammable, explosive, chemical-laden or wet atmospheres.

In cases in which property damage may result from malfunction of the heater, a backup system or a temperature sensitive alarm should be used.

▲ CAUTION The open end of piping systems being purged shall not discharge into areas where there are sources of ignition or into confined spaces UNLESS precautions are taken as follows: (1) By ventilation of the space, (2) control of purging rate, (3) elimination of all hazardous conditions. All precautions must be taken to perform this operation in a safe manner!

Unless otherwise specified, the following conversions may be used for calculating SI unit measurements:	
1 foot = 0.305 m	1000 Btu per hour = 0.293 kW
1 inch = 25.4 mm	1 inch water column = 0.249 kPa
1 gallon = 3.785 L	1000 Btu/Cu. Ft. = 37.5 MJ/m ³
1 pound = 0.453 kg	liter/second = CFM x 0.472
1 psig = 6.894 kPa	meter/second = FPM ÷ 196.8
1 cubic foot = 0.028 m ³	

SPECIFICATIONS

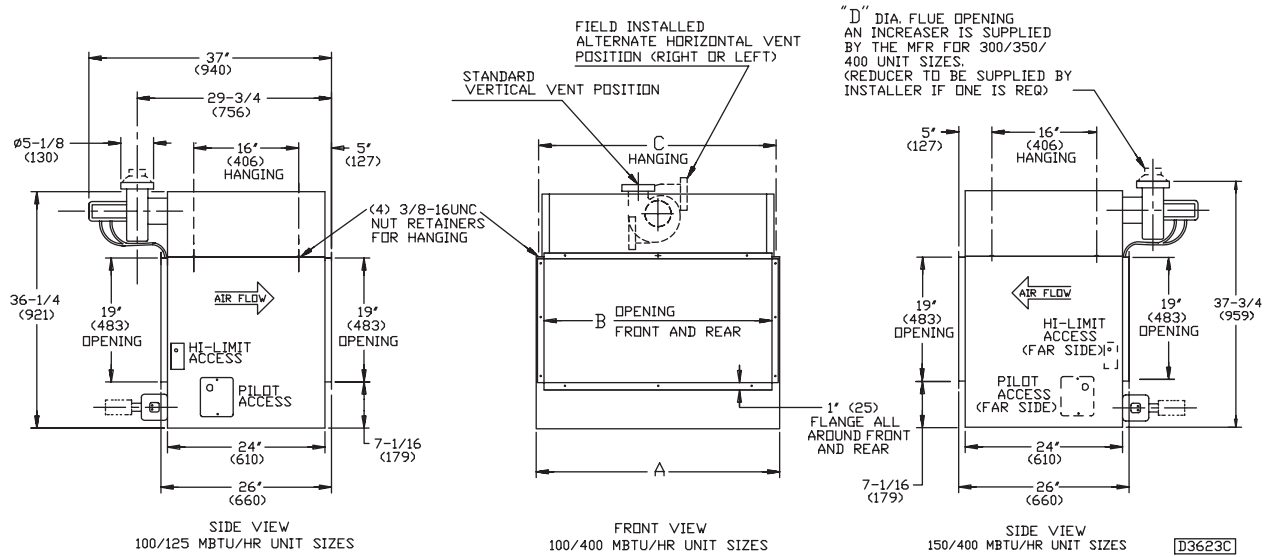

Table 1 - Power Vented Duct Furnace

UNIT SIZE	A inches (mm)	B inches (mm)	C inches (mm)	D (Dia) inches (mm)	F inches (mm)	GAS INLET inches		WEIGHT lb. (kg)
						NAT.	LP	
100	17-7/8 (454)	15-1/2 (394)	17-1/8 (435)	4 (102)	23-7/8 (606)	1/2	1/2	173 (78)
125	20-5/8 (524)	18-1/4 (464)	19-7/8 (505)	4 (102)	25-5/8 (651)	1/2	1/2	186 (84)
150	20-5/8 (524)	18-1/4 (464)	19-7/8 (505)	4 (102)	26-5/8 (676)	1/2	1/2	197 (89)
175	23-3/8 (594)	21 (533)	22-5/8 (575)	4 (102)	29-3/8 (746)	1/2	1/2	216 (98)
200	26-1/8 (664)	23-3/4 (603)	25-3/8 (645)	5 (127)	32-1/8 (816)	1/2	1/2	232 (105)
225	28-7/8 (733)	26-1/2 (673)	28-1/8 (714)	5 (127)	34-7/8 (886)	3/4	1/2 OR 3/4	254 (115)
250	31-5/8 (803)	29-1/4 (743)	30-7/8 (784)	5 (127)	37-5/8 (956)	3/4	1/2 OR 3/4	263 (119)
300	37-1/8 (943)	34-3/4 (883)	36-3/8 (924)	6 (152)	43-1/8 (1095)	3/4	1/2 OR 3/4	312 (142)
350	42-5/8 (1083)	40-1/4 (1022)	41-7/8 (1064)	6 (152)	48-5/8 (1235)	3/4	1/2 OR 3/4	389 (176)
400	48-1/8 (1222)	45-3/4 (1162)	47-3/8 (1203)	6 (152)	54-1/8 (1375)	3/4	1/2 OR 3/4	403 (183)

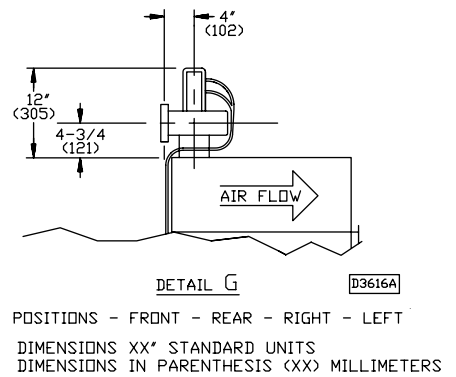

Figure 2 - Power Vented Duct Furnace — Side Service Access

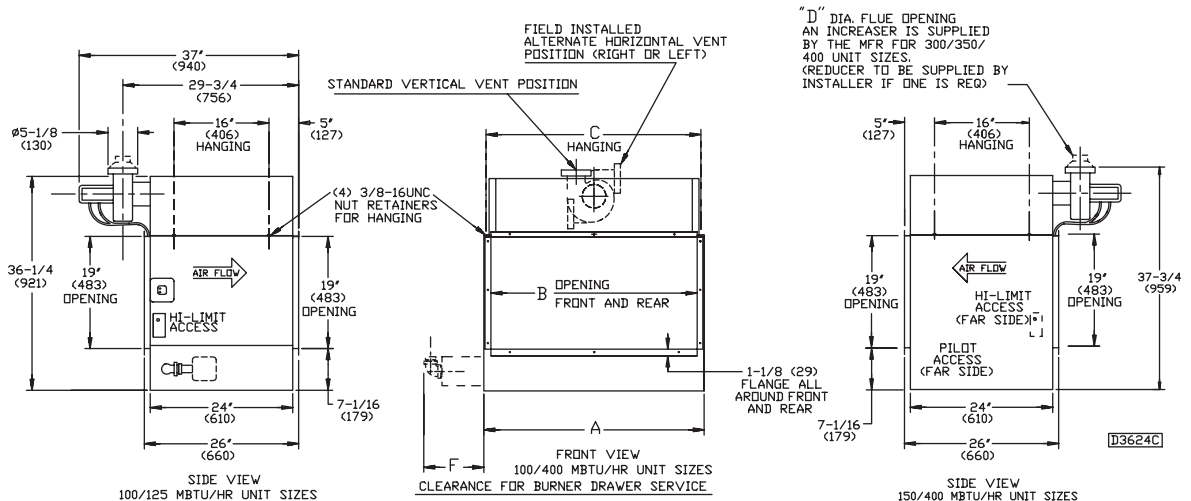

Table 2

PERFORMANCE DATA

UNIT SIZE	INPUT		OUTPUT MBH (kW)	FULL LOAD		Temperature			Temperature		
	(MAX) MBH (kW)	(MIN) MBH (kW)		LOAD AMPS	MCA	MINIMUM CFM (cu. m/s)	Rise °F (°C)	PD inches of Water (kPa)	MAXIMUM CFM (cu. m/s)	Rise °F (°C)	PD inches of Water (kPa)
100	100	50	80	1.9	2.3	929	80	0.12	2469	30	0.90
	(29.3)	(14.6)		(23.4)	1.9						
125	125	62.5	100	1.9	2.3	1157	80	0.13	3086	30	0.80
	(36.6)	(18.3)		(29.3)	1.9						
150	150	75	120	1.9	2.3	1389	80	0.15	3704	30	0.75
	(43.9)	(22.0)		(35.1)	1.9						
175	175	87.5	140	1.9	2.3	1620	80	0.14	4321	30	0.75
	(51.2)	(25.6)		(41.0)	1.9						
200	200	100	160	1.9	2.3	1852	80	0.14	4938	30	0.75
	(58.6)	(29.3)		(46.9)	1.9						
225	225	112.5	180	1.9	2.3	2083	80	0.14	5556	30	0.75
	(65.9)	(32.9)		(52.7)	1.9						
250	250	125	200	1.9	2.3	2315	80	0.14	6173	30	0.80
	(73.2)	(36.6)		(58.6)	1.9						
300	300	150	240	1.9	2.3	2778	80	0.13	7407	30	0.90
	(87.8)	(43.9)		(70.3)	1.9						
350	350	175	280	1.9	2.3	3241	80	0.13	8642	30	0.90
	(102.5)	(51.2)		(82.0)	1.9						
400	400	200	320	1.9	2.3	3704	80	0.14	9877	30	0.90
	(117.1)	(58.6)		(93.7)	1.9						

Ratings are shown for unit installations at elevations between 0 and 2,000 feet (610m). For unit installations in U.S.A. above 2,000 feet (610m), the unit input must be derated 4% for each 1,000 feet (305m) above sea level; refer to local codes, or in absence of local codes, refer to the latest edition of the National Fuel Gas Code, ANSI Standard Z223.1 (NFPA No. 54). For installations in Canada, any references to deration at altitudes in excess of 2,000 feet (610m) are to be ignored. At altitudes of 2,000 to 4,500 feet (610 to 1372m), the unit must be derated 90% of the normal altitude rating, and be so marked in accordance with the ETL certification.

TEMPERATURE RISE AND PRESSURE DROP GRAPH

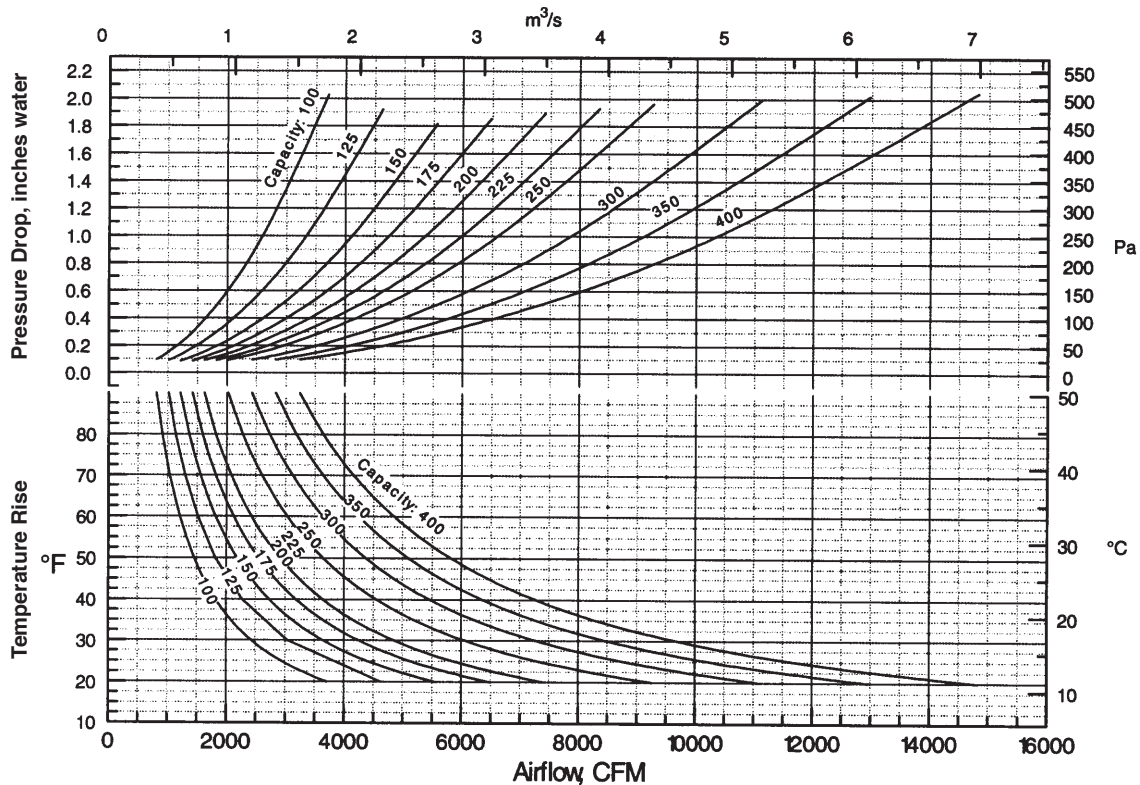

INSTALLATION

▲ CAUTION Do not install duct furnaces in corrosive or flammable atmospheres! Premature failure of, or severe damage to the unit will result!

▲ CAUTION Avoid locations where extreme drafts can affect burner operation. Duct furnaces must not be installed in locations where air for combustion would contain chlorinated, halogenated or acidic vapors. If located in such an environment, premature failure of the unit will occur!

NOTICE: Location of duct furnaces is related directly to the selection of sizes. Basic rules are as follows:

ACCESSIBILITY: If unit is a bottom service access type allow a minimum of 21 inches (533mm) at the bottom of the unit to facilitate servicing the burners and pilot, or six inches (152mm) if the unit has a side access burner drawer. Provision should also be made to assure accessibility for recurrent maintenance purposes. See Table 1, dimension "F" for required service clearance for burner drawer on side service models.

AIRCRAFT HANGARS: Duct furnaces must be installed in aircraft hangars and public garages as follows: In aircraft hangars, duct furnaces must be at least 10 feet (3.05m) above the upper surface of wings or engine enclosures of the highest aircraft to be stored in the hangar and 8 feet (2.4m) above the floor in shops, offices and other sections of the hangar where aircraft are not stored or housed. Refer to current ANSI/NFPA No. 409, Aircraft Hangars. In Canada, installation is suitable in aircraft hangars when acceptable to the enforcing authorities.

PUBLIC GARAGES: In repair garages, duct furnaces must be installed in a detached building or room separated from repair areas as specified in the latest edition of NFPA 88B, Repair Garages.

In parking structures, duct furnaces must be installed so that the burner flames are located a minimum of 18 inches (457mm) above the floor or protected by a partition not less than 18 inches (457mm) high. Refer to the latest edition of NFPA 88A, Parking Structures.

In Canada, installation must be in accordance with the latest edition of CSA B149 "Installation Codes for Gas Burning Appliances and Equipment."

When the unit is equipped with an automatic gas ignition system, the duct furnace must be installed such that the gas ignition control system is not directly exposed to water spray, rain or dripping water.

Duct furnaces should not be installed to maintain low temperatures and/or freeze protection of buildings. A minimum of 50°F (10°C) thermostat setting must be maintained. If duct furnaces are operated to maintain lower than 50°F (10°C), hot flue gases are cooled inside the heat exchanger to the point where water vapor (a flue gas by product) condenses onto the heat exchanger walls. The result is a mildly corrosive acid that prematurely corrodes the aluminized heat exchanger and can actually drip water down from the duct furnace onto floor surface. Additional duct furnaces should be installed if a minimum 50°F (10°C) thermostat setting cannot be maintained.

CLEARANCES

▲ WARNING Under no circumstances should combustible material be located within the clearances specified in Table 3. Failure to provide proper clearance could result in personal injury or equipment damage from fire.

Maintain adequate clearances around air openings into combustion chamber:

Table 3 - Minimum Clearances†

Sides	6 inches (152 mm)
Top	6 inches (152 mm)
Bottom*	6 inches (152 mm)
Flue	6 inches (152 mm)

†*21 inches (533 mm) is required for accessibility on furnaces with bottom access burner compartments.

†When the clearances required for accessibility are greater than the minimum safety clearances, the accessibility clearances take precedence.

DRAFTS: Avoid installing the duct furnace in an extremely drafty location. Strong drafts may cause pilot outage. Units with intermittent pilot ignition may be preferable in areas where drafts cannot be avoided.

Atmospheres containing commercial solvents or chlorinated hydrocarbons will produce corrosive acids when coming in contact with the flames. This will greatly reduce the life of the gas duct furnace and may void the warranty. Avoid such areas.

NOTICE: If the gas duct furnace is to be used in a building classified as having a hazardous atmosphere, the installation must comply with the standards set by the National Board of Fire Underwriters. Consult the authorities having jurisdiction before starting the job.

The duct furnace must be installed on the positive pressure side of the air circulation blower.

INSTALLATION

DUCTWORK

Properly designed and installed ductwork, providing a uniformly distributed flow of air across the surfaces of the heat exchanger, is essential to satisfactory unit performance and life of the equipment.

All duct connection flanges/seams must be sealed to prevent air leaks. Sealant/tape must be suitable for temperatures 250°F (121°C) minimum.

▲ WARNING Any attempt to straighten the 90° duct connection flanges on the duct furnaces will affect the operation of the furnace and will void the warranty.

If uniform air distribution is not obtained, install additional baffles and/or turning vanes in the ductwork.

Figures 3 and 4 illustrate recommended ductwork designs for both the straight-through and elbowed air inlet arrangements.

Access panels large enough to observe smoke and reflected light, and to detect the presence of leaks in the heating equipment, are required both upstream and downstream from gas duct furnaces. These panels must be sealed to prevent air leaks. If allowed by local regulations, install canvas connectors between the ductwork and fan discharge opening to eliminate the transmission of mechanical vibration.

AIR FLOW

The installation is to be adjusted to obtain an air throughput within the range specified on the appliance rating plate.

COMBUSTION INLET AIR VENTILATION

Inlet Air From Another Room — If the duct furnace is installed in a tightly constructed room or compartment, provide two inlet air openings. The size of each vent opening should be no less than one square inch (6.452 square centimeters) of free area for each 1000 Btu/hr. (293 W) input. Each opening must not be less than 100 square inches (645 square centimeters).

Figure 3 - Recommended Design for Field Installation of Ductwork for Straight-Through Arrangement

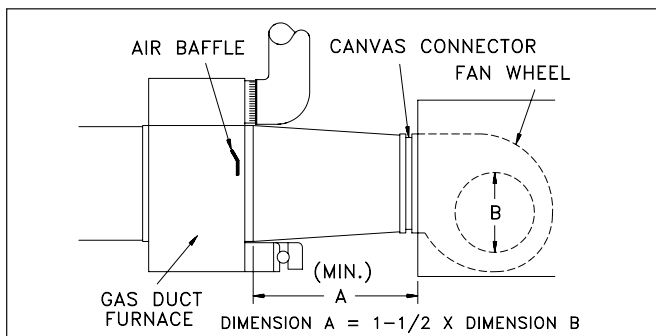

Inlet Air From Outdoors — If the enclosed space is to have inlet combustion air from the outside, the vent opening must not be smaller than one square inch (6.452 square centimeters) of free area for each 2500-3000 Btu/hr. (733-879 W) input. Each opening must not be less than 100 square inches (645 square centimeters).

CONDENSATE: The duct furnace may be installed on the downstream side of a cooling coil, without need of a bypass duct. In some space conditions, condensate can form in the heat exchanger of the duct furnace when installed downstream from a cooling coil. Under these conditions, a field provided drain flange (also referred to as a waste nut) may be installed on the furnace bottom.

To install the drain flange, a hole should be drilled in the bottom of the burner section. The drain flange should then be bolted to the exterior of the unit, directly over the hole in the bottom of the drain pan. Any holes in the bottom of the pan not covered by the drain flange, should be sealed with RTV sealant. Condensate piping should terminate outside of the building. Periodic cleaning of the condensate piping is required to ensure proper condensate flow.

BYPASS

When a gas duct furnace is installed to operate in conjunction with a summer air conditioning system, the CFM air delivery of the system blower should be adjusted to meet the design air volume requirements for cooling. If this CFM delivery is greater than that required for heating, resulting in a low air temperature rise, install a damper bypass around the gas duct furnace to bypass a portion of the air.

▲ WARNING Insure that all hardware used in the suspension or each unit heater is more than adequate for the job. Failure to do so may result in extensive property damage, personal injury or death.

Figure 4 - Recommended Ductwork Design for Elbowed Arrangement

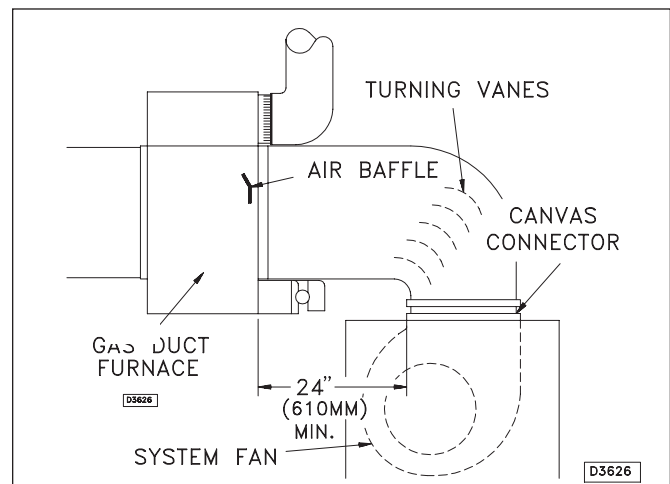

SUSPENSION

▲ CAUTION The duct furnace must be hung level from side to side and front to back, from four suspension points provided at the top of the unit. Failure to do so will result in poor performance and/or premature failure of the unit. Refer to Figure 5 for typical suspension arrangements. **DO NOT** mount duct furnaces in series (one in front of another).

NOTICE: When mounting duct furnaces side by side, units must have opposite side gas connections (determined by Digit #6 - Furnace Type in the unit number). Minimum safety clearances must also be maintained; see Table 3. When service/accessibility clearances are greater than minimum safety clearances, service/accessibility clearances take precedence. See "Accessibility" section under "Installation".

Figure 5

TYPICAL "SIDE BY SIDE" (8) POINT DUCT SUSPENDING ARRANGEMENT

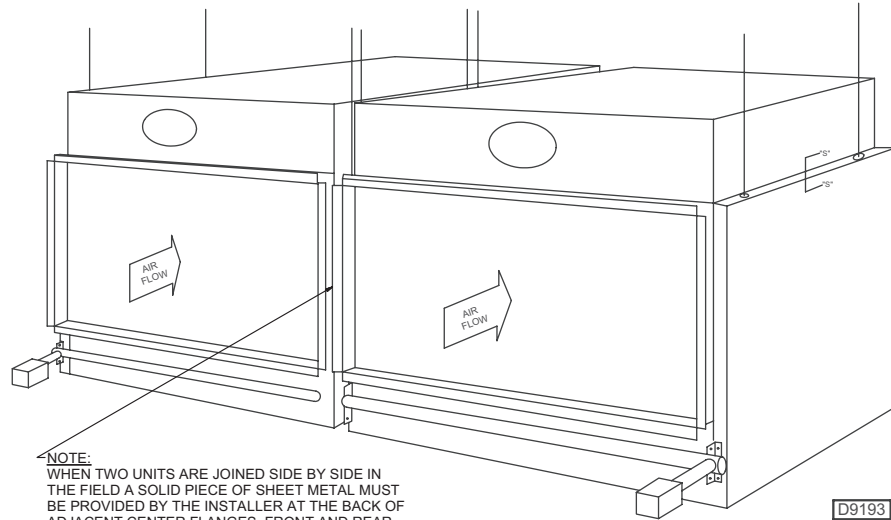

NOTE: WHEN TWO UNITS ARE JOINED SIDE BY SIDE IN THE FIELD A SOLID PIECE OF SHEET METAL MUST BE PROVIDED BY THE INSTALLER AT THE BACK OF ADJACENT CENTER FLANGES, FRONT AND REAR.

▲ WARNING MAKE CERTAIN THAT THE LIFTING METHODS USED TO LIFT THE UNIT HEATER ARE CAPABLE OF SUPPORTING THE WEIGHT OF THE HEATER DURING INSTALLATION. FAILURE TO HEED THIS WARNING MAY RESULT IN PROPERTY DAMAGE OR PERSONAL INJURY.

TYPICAL (4) POINT DUCT SUSPENDING ARRANGEMENT

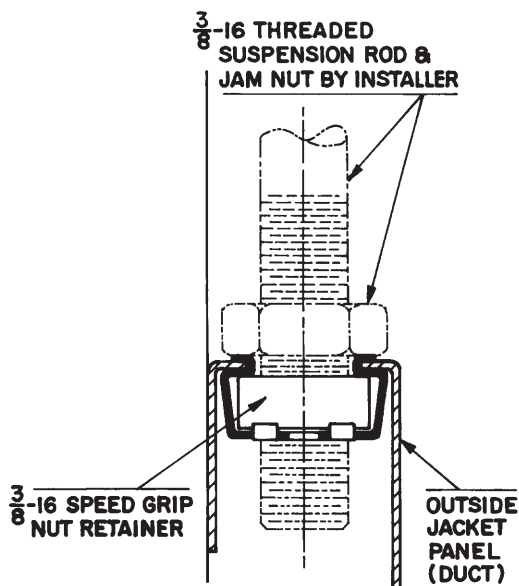
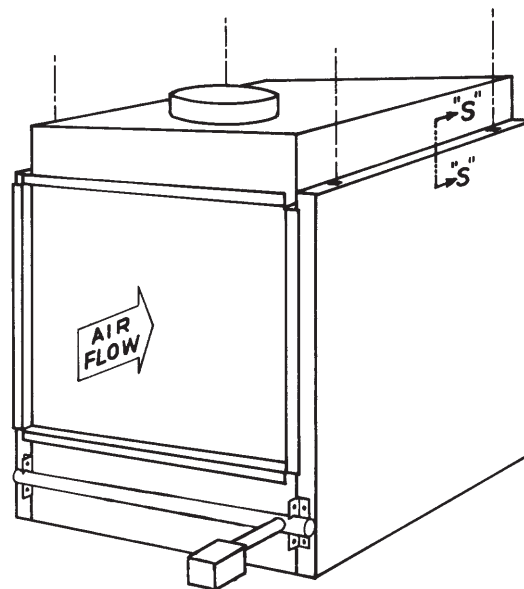

SECTION "S"- "S"
DETAIL SHOWING RECOMMENDED METHOD OF SUSPENDING (TYPICAL)

▲ WARNING MAKE CERTAIN THAT THE STRUCTURE TO WHICH THE FURNACE IS TO BE MOUNTED IS CAPABLE OF SAFELY SUPPORTING ITS WEIGHT. UNDER NO CIRCUMSTANCES MUST THE GAS LINES, VENTING SYSTEM OR THE ELECTRICAL CONDUIT BE USED TO SUPPORT THE HEATER OR ANY OTHER OBJECTS (I.E. LADDER, PERSON) LEAN AGAINST THE HEATER GAS LINES, VENTING SYSTEM OR ELECTRICAL CONDUIT FOR SUPPORT. FAILURE TO HEED THESE WARNINGS MAY RESULT IN PROPERTY DAMAGE, PERSONAL INJURY OR DEATH.

ELECTRICAL CONNECTIONS



Standard units are shipped for use on 115 volt, 60 hertz single phase electric power. The motor name-plate and electrical rating on the transformer should be checked before energizing the duct furnace electrical system. All external wiring must conform to the latest edition of ANSI/NFPA No. 70, National Electrical Code and applicable local codes; in Canada, to the Canadian Electrical Code, Part 1 CSA Standard C22.1.

▲ CAUTION Do not use any tools (i.e. screwdriver, pliers, etc.) across the terminals to check for power. Use a voltmeter.

▲ CAUTION USE COPPER CONDUCTORS ONLY! UNIT TERMINALS ARE NOT DESIGNED TO ACCEPT OTHER TYPES OF CONDUCTORS. Failure to do so may cause damage to the equipment.

It is recommended that the electrical power supply to each duct furnace be provided by a separate, fused and permanently live electrical circuit. A disconnect switch of suitable electrical rating for each duct furnace should be located as close to the gas valve and controls as possible. Each duct furnace must be electrically grounded in accordance with the latest edition of the National Electric Code, ANSI/NFPA No. 70 or CSA Standard C22.1.

THERMOSTAT WIRING AND LOCATION

NOTICE: The thermostat must be mounted on a vertical vibration-free surface free from air currents and in accordance with the furnished instructions.

Mount the thermostat approximately 5 feet (1.5 m) above the floor in an area where it will be exposed to a free circulation of average temperature air. Always refer to the thermostat instructions as well as our unit wiring diagram and wire accordingly. Avoid mounting the thermostat in the following locations:

1. Cold areas - Outside walls or areas where drafts may affect the operation of the control.
2. Hot areas - Areas where the sun's rays, radiation, or warm air currents may affect control operation.
3. Dead areas - Areas where air cannot circulate freely, such as behind doors or in corners.

* Thermostat wires tagged "W" and "G" must be connected together except when using a general purpose "SPDT" 24VAC relay and a standard thermostat with subbase, or when using Honeywell T834H or T834N thermostats. Also refer to wiring diagram (factory provided with each unit) for other wiring connections.

Figure 6 - C1267G

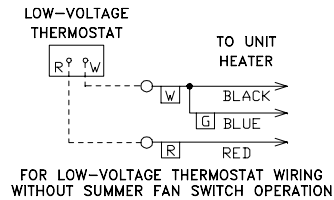

THERMOSTAT HEAT ANTICIPATOR ADJUSTMENTS:

The initial heat anticipator setpoint should equal the heater control circuit's current (amperage) draw when the unit is firing. This current should be measured for the best results. Use the recommended ranges as a guide. If further information is needed, consult your thermostat manufacturer's instructions.

Recommended Heat Anticipator Setting Ranges:

Gas Ignition Type	25 feet (7.6m)	50 feet (15.2m)
	Thermostat Wiring	Thermostat Wiring
For Power Vented Units: Intermittent (Spark)	0.85 to 0.90 A	0.90 to 1.1 A Maximum Setting on Thermostat

FAN TIME DELAY CONTROL

Leads from time delay controls are factory wired to the junction box (when ordered as an optional component). The fan control is a time delay relay (approximately 45 seconds ON, 65 seconds OFF). The fan control is rated at 17 amps.

NOTICE: The start-up fan delay must not exceed 90 seconds from a cold start.

NOTICE: For all wiring connections, refer to the wiring diagram that your unit is equipped with (either affixed to the side jacket or enclosed in your unit's installation instruction envelope). Should any original wire supplied with the heater have to be replaced, it must be replaced with wiring material having a temperature rating of at least 105°C.

Should any high limit switch wires have to be replaced, they must be replaced with wiring material having a temperature rating of 200°C minimum.

VENTING

ANSI now organizes vented appliances into four categories.

Venting Categories

	Non Condensing	Condensing
Negative Vent Pressure	I	II
Positive Vent Pressure	III	IV

Category I

Includes non-condensing appliances with negative vent pressure, like the traditional atmospheric unit heater.

Category II

Groups condensing appliances with negative vent pressure.

Category III

Appliances are non-condensing and operate with a positive vent pressure.

Category IV

Covers condensing appliances with positive vent pressure.

NOTICE: Category II and IV do not apply to equipment specified within this manual.

VENTING FOR POWER VENTED (CATEGORY III) DUCT FURNACES (Figures 1 and 2)

ALL DUCT FURNACES MUST BE VENTED! All venting installations shall be in accordance with the latest edition of Part 7, venting of Equipment of the National Fuel Gas Code, ANSI Z223.1, or applicable provisions of local building codes for natural or power vented units. Also see page 13 for additional Canadian installations.

Horizontal vent systems must be in compliance with UL 1738 for installations in the United States, and ULS636 for installations in Canada.

Power vented units are designed to be used with single wall vent pipe utilizing horizontal or vertical venting arrangements. These arrangements must **terminate external** to the building using either a single wall or double wall vent. See Figure 7 thru 13 for special installation requirements regarding these venting conditions.

▲ WARNING Do not use a type B (double wall) vent internally within the building on power vented units!

If double wall venting is used, components which are UL Listed and approved for Category III positive pressure venting systems **MUST** be used.

A Briedart Type L, Field Starkap or an equivalent vent cap must be supplied by the customer for each power vented unit. The vent pipe diameter **MUST** be as specified in Table 1 ("D" Dia. Flue Opening). A reducer must be field installed for 100 through 175 MBH Unit Sizes. All 300 through 400 MBH Unit sizes are factory equipped with the required flue increaser. Refer to Figures 11 thru 13 for additional requirements.

Refer to Table 4 for vent termination clearance requirements.

Through the wall vents for these appliances shall **NOT** terminate over public walkways, or over an area where condensate or vapor could create a nuisance or hazard or could be detrimental to the operation of regulators, relief valves, or other equipment.

The vent pipe equivalent length must be 5 feet (1.5m) minimum and must not exceed 50 feet (15.2m). Equivalent length is the total length of straight sections **PLUS** 15 feet (4.6m) for each 90 degree elbow, 8 feet (2.4m) for each 45 degree elbow, and 10 feet (3.0m) for the vent cap.

Maintain 6 inches (152mm) between vent pipe and combustible materials. A minimum of 12 inches (305mm) of straight pipe is required from the venter outlet before installing an elbow in the vent system. **An elbow should never be attached directly to the venter!**

Use single wall pipe constructed of 26 gauge galvanized steel or material of equivalent durability and corrosion resistance for the vent system. For installation in Canada, use pipe constructed from 0.025 inch thick aluminum or 0.018 inch thick stainless steel.

▲ WARNING Never use a pipe of a diameter other than that specified in Table 1! Never use PVC or other nonmetallic pipe for venting! To do so may result in serious damage to the unit or severe personal injury or death!

Any run of single wall vent pipe passing through an unheated space must be insulated with an insulation suitable to 550°F.

Seal ALL vent pipe joints and seams to prevent leakage. Use General Electric RTV-108 or Dow-Corning RTV-732 silicone sealant or 3M #425 aluminum foil tape or equivalent.

The vent system must be installed to prevent collection of condensate. Vertical vent pipes should be equipped with condensate drains. Pitch horizontal pipes downward 1/4 in. per foot (21mm/m) toward outlet for condensate drainage.

Horizontal portions of the venting system shall be supported at maximum intervals of 4 feet (1.2m) to prevent sagging (in Canada, support at 3 feet (1m) maximum intervals).

Insulate single wall vent pipe exposed to cold air or running through unheated areas.

Each unit must have an individual vent pipe and vent terminal per furnace section! Each unit **MUST NOT** be connected to other vent systems or to a chimney.

Units are shipped from the factory set up for vertical venting. To convert the power venter for horizontal venting, remove the shipping support bracket, and follow this procedure:

1. Hold power venter motor in position.
2. Remove the three Phillips-head screws from the motor adaptor plate.
3. Remove the three screws which connect the power venter stack to the power venter housing.
4. Rotate the power venter housing to the horizontal position.
5. Replace screws accordingly.

NOTICE: The motor, pressure switch, and junction box bracket MUST remain located as shipped from the factory. Rotate only the blower housing! If the power venter housing is to be moved to the right horizontal position, the junction box must be rotated 90 degrees CCW to clear the connection. To do this, remove all wires, conduit and conduit connector from the junction box, noting location of wires. Move box, using holes provided. Move 7/8 inch plug from bottom of box to side. Reconnect all wires according to the unit's wiring diagram.

**Figure 7
(Optional)
Top Vent
Position**
Rear, Front,
Right & Left
Flue Positions

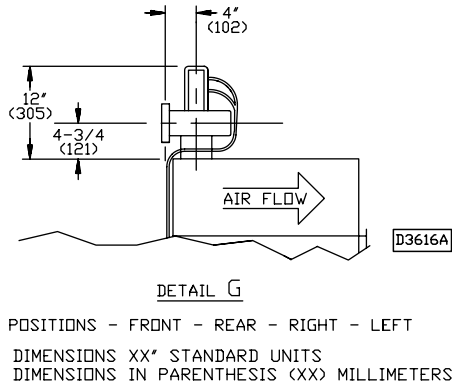
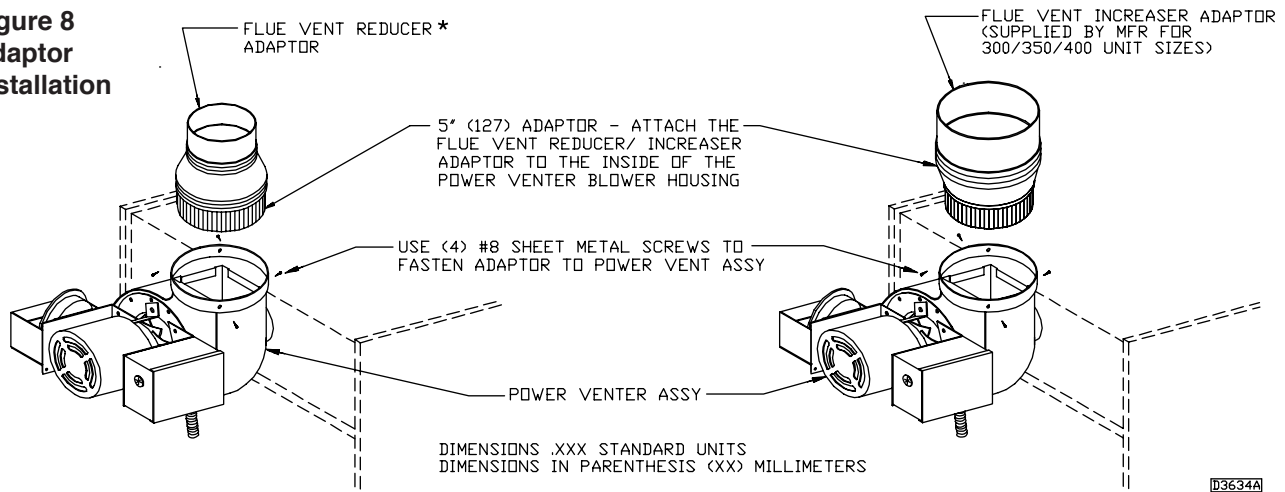

Table 4

Vent Systems Termination Clearance Requirements		
Structure/Object	Minimum Clearance for Termination Locations	
	USA	CANADA
Door, window, or gravity vent inlet; combustion air inlet for other appliances	9 in. for 10,000 to 50,000 BTU/Hr input; 12 in. for input exceeding 50,000 BTU/Hr.	9 in. (230mm) for 10,000 to 50,000 BTU/Hr input; 12 in. (305mm) for input exceeding 50,000 BTU/Hr.
Forced air inlet within 10 ft.	3 ft. above	6 ft. (1.8m)
Adjoining building or parapet	10 ft.	10 ft. (3.04m)
Adjacent public walkways	7 ft. above grade	7 ft. (2.1m) above grade
Electric, gas meters & regulators	4 ft. horizontal	3 ft. (0.9m) horizontally from meter/regulator assembly. 6 ft. (1.8m), any direction, from a gas service regulator vent outlet
Above grade level*	1 ft.	1 ft. (0.3m)

*Minimum above maximum snow depth, or per local code, whichever is greater.

**Figure 8
Adaptor
Installation**



REFER TO SPECIFICATION TABLE AND INSTALLATION MANUAL FOR PROPER USAGE

The following instructions apply to Canadian installations in addition to installation and operating instructions:

1. Installation must conform with local building codes, or in absence of local codes, with current CSA B149.1 installation codes for natural gas burning appliances and equipment, or CSA B149.2, installation codes for propane gas burning appliances and equipment.
2. Any references to U.S. standards or codes in these instructions are to be ignored and the applicable Canadian standards or codes applied.

3. If using a metal vent system under positive gauge pressure in Canada, a slip fit vent connection must be secured by at least two corrosion-resistant screws, or other mechanical locking means.
4. See Table 4 for Canadian Vent Termination clearance requirements.

* USA units - the reducer must be field supplied for 100, 125, 150 and 175 MBH unit sizes.

Figure 9A

HORIZONTAL ARRANGEMENT

SINGLE WALL VENT SYSTEM TO SINGLE WALL TERMINATION

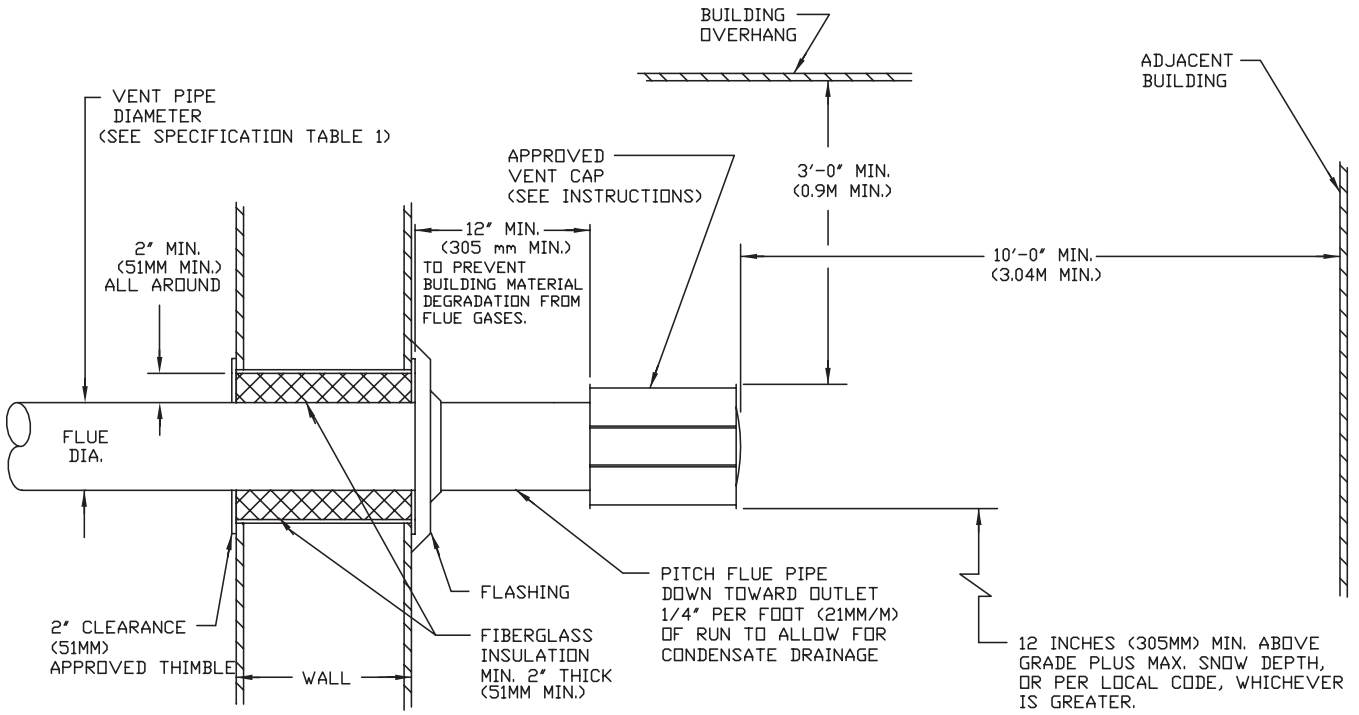

D3620F

Figure 9B

VERTICAL ARRANGEMENT

SINGLE WALL VENT SYSTEM TO SINGLE WALL TERMINATION

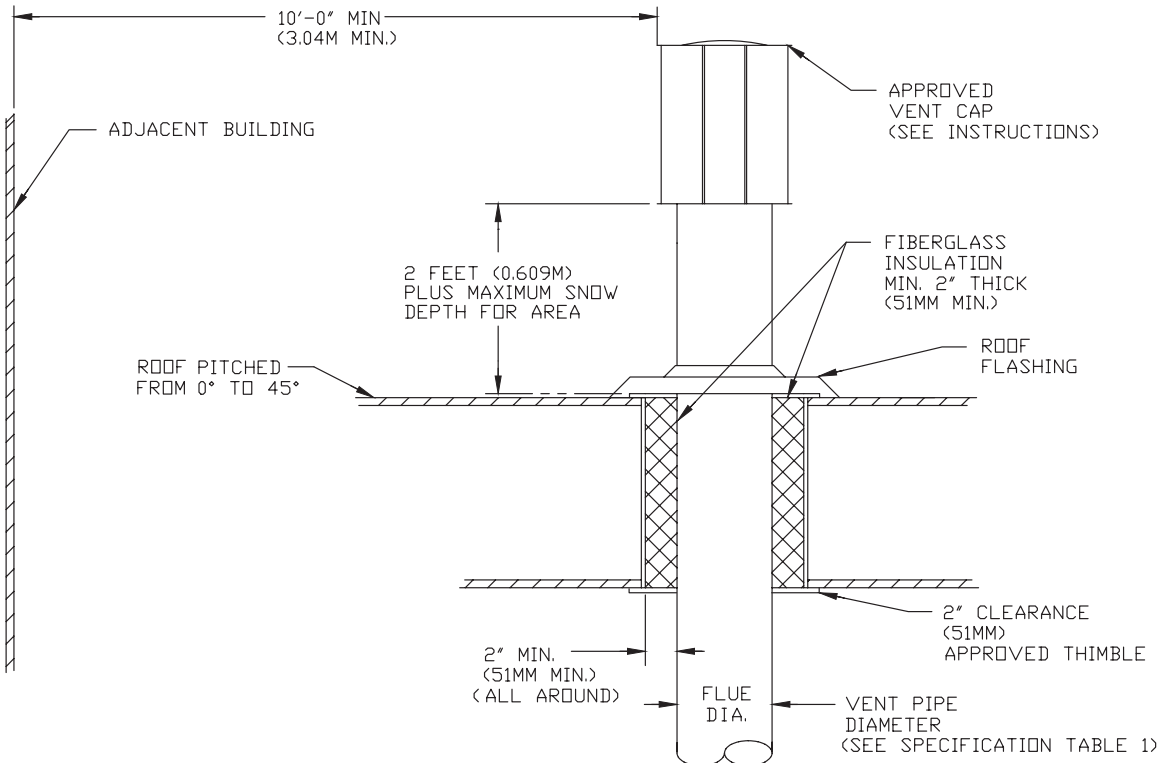

D3619D

Figure 10A

HORIZONTAL ARRANGEMENT

SINGLE WALL VENT SYSTEM TO DOUBLE WALL TERMINATION

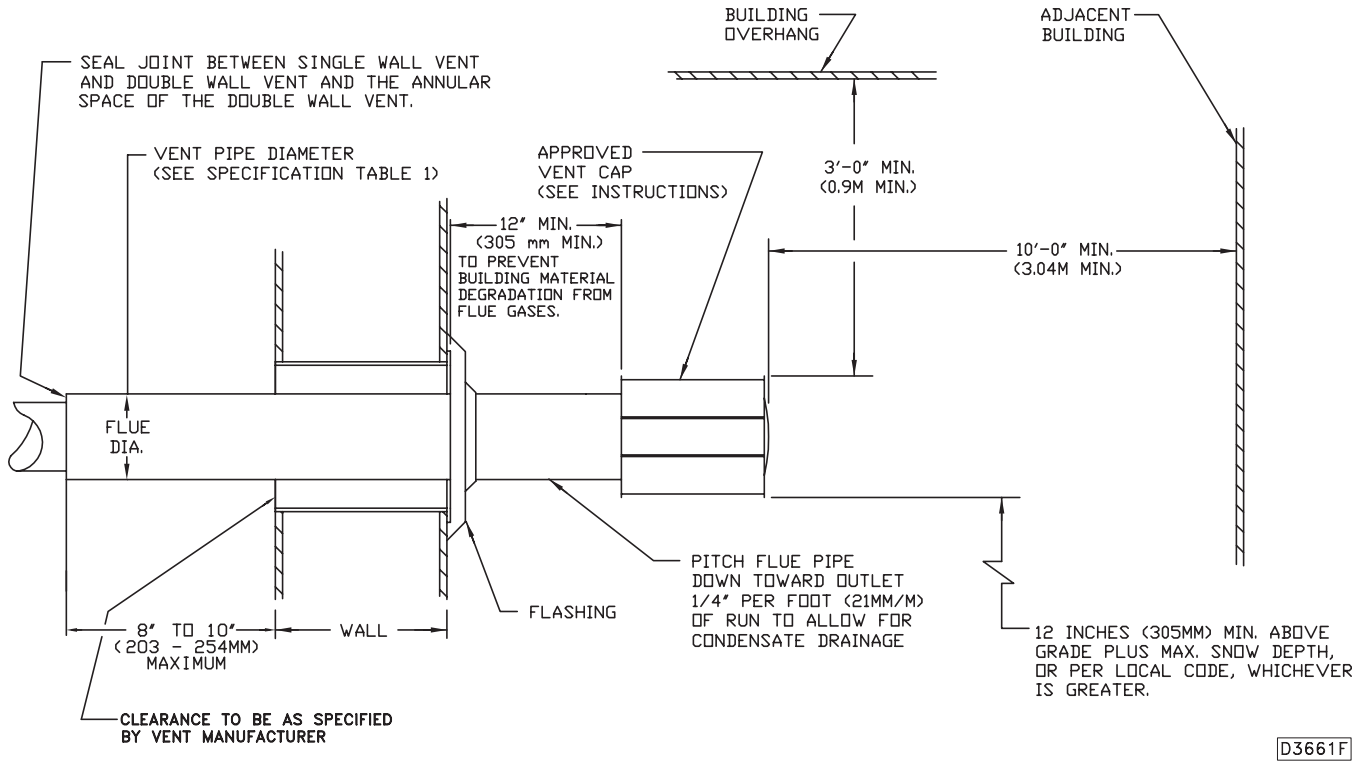
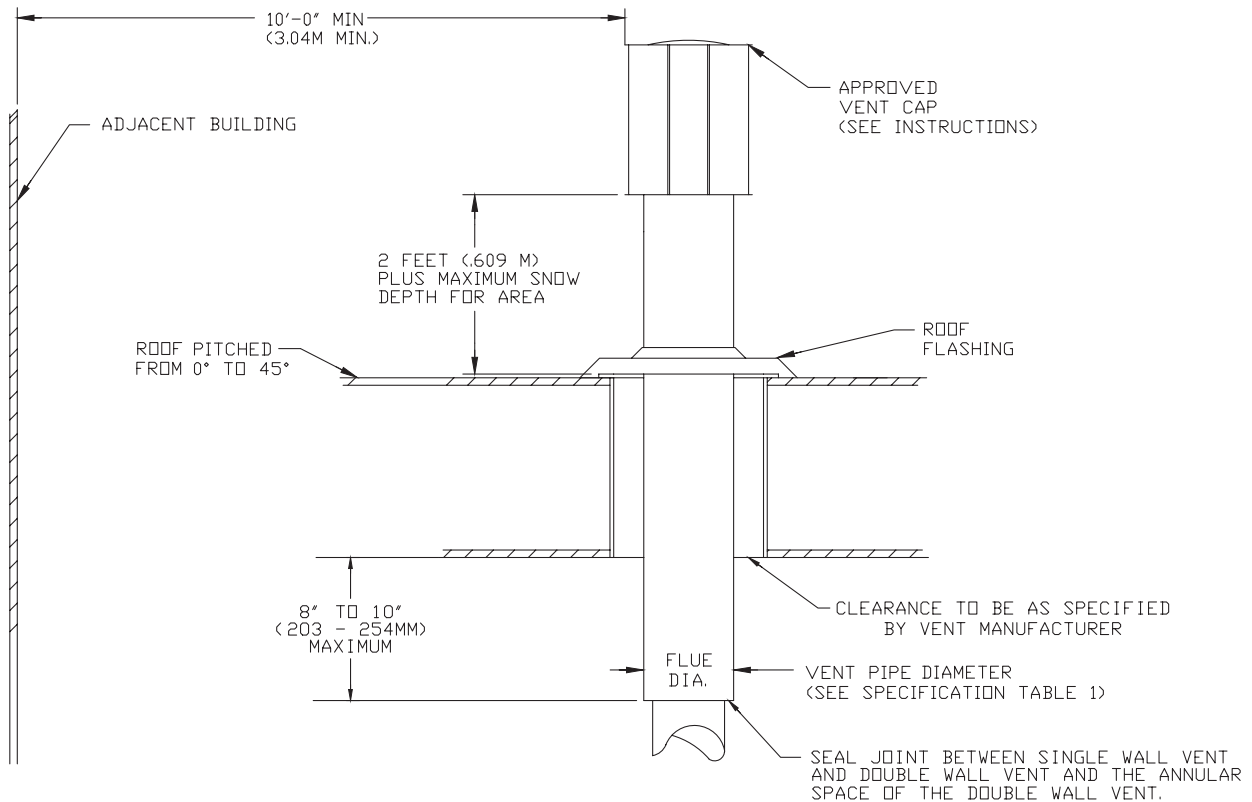

Figure 10B

VERTICAL ARRANGEMENT

SINGLE WALL VENT SYSTEM TO DOUBLE WALL TERMINATION



D3662E

Figure 11

Horizontal Left Vent Position
(Rear View of Heater)

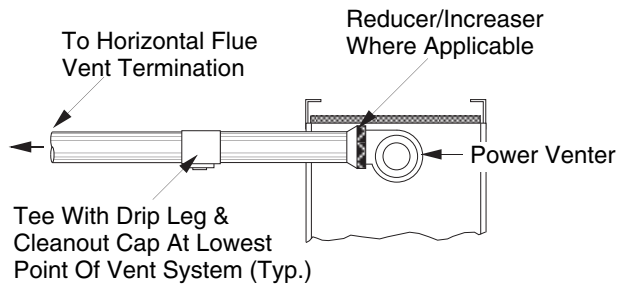

Figure 12

Horizontal Right Vent Position
(Rear View of Unit Heater)

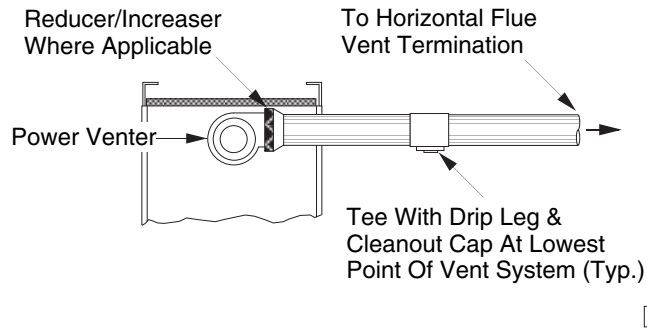
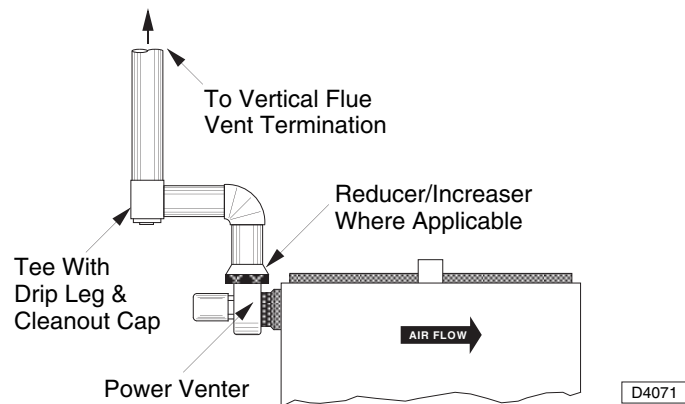

Figure 13

Vertical Vent Position
(Side View of Unit Heater)



GAS PIPING

▲ WARNING To avoid equipment damage or possible personal injury, do not connect gas piping to this unit until a supply line pressure/leak test has been completed. Connecting the unit before completing the pressure/leak test may damage the unit gas valve and result in a fire hazard.

Do not rely on a shut off valve to isolate the unit while conducting gas pressure/leak tests. These valves may not be completely shut off, exposing the unit gas valve to excessive pressure and damage.

PIPE SIZING

To provide adequate gas pressure at the gas duct furnace, size the gas piping as follows:

- Find the cu ft/hr by using the following formula:

$$\text{Cu ft/hr} = \frac{\text{Input}}{\text{Btu}}$$

- Refer to Table 5. Match "Legth of Pipe" with appropriate "Gas Input - Cu Ft/Hr" figure. This figure can then be matched to the pipe size at the end of the column.

Example: It is determined that a 67 foot (20.4m) run of gas pipe is required to connect a 200 MBTU gas duct furnace to a 1,000 Btu/cu. ft (0.29 kW) natural gas supply.

$$\frac{200,000 \text{ Btu/hr}}{1,000 \text{ Btu/cu ft}} = 200 \text{ Cu ft/hr}$$

Using Table 5, a 1 inch nominal diameter pipe is needed.

NOTICE: See General Safety Information section for english/SI (metric) unit conversion factors.

NOTICE: If more than one gas duct furnace is to be served by the same piping arrangement, the total cu ft/hr input and length of pipe must be considered.

NOTICE: If the gas duct furnace is to be fired with LP gas, see below and consult the local LP gas dealer for pipe size information.

NOTICE: HEATER INSTALLATION FOR USE WITH PROPANE (BOTTLED) GAS MUST BE MADE BY A QUALIFIED L.P. GAS DEALER OR INSTALLER. HE WILL INSURE THAT PROPER JOINT COMPOUNDS ARE USED FOR MAKING PIPE CONNECTIONS; THAT AIR IS PURGED FROM LINES; THAT A THOROUGH TEST IS MADE FOR LEAKS BEFORE OPERATING HEATER; AND THAT IT IS PROPERLY CONNECTED TO PROPANE GAS SUPPLY SYSTEM.

Before any connection is made to an existing line supplying other gas appliances, contact the local gas company to make certain that the existing line is of adequate size to handle the combined load.

Table 5

GAS PIPE SIZE

Maximum Capacity of Pipe in Cubic Feet of Gas per Hour for Gas Pressures of 0.5 psi (3.5 kPa) or Less, and a Pressure Drop of 0.5 Inch Water Column (124.4 Pa)
(Based on a 0.60 Specific Gravity Gas)

Nominal Iron Pipe Size inches	Internal Diameter inches (mm)	Length of Pipe, feet (Meters)													
		10 (3.0)	20 (6.1)	30 (9.1)	40 (12.2)	50 (15.2)	60 (18.3)	70 (21.3)	80 (24.4)	90 (27.4)	100 (30.5)	125 (38.1)	150 (45.7)	175 (53.3)	200 (61.0)
1/2	0.622	175	120	97	82	73	66	61	57	53	50	44	40	37	35
	(16)	(4.96)	(3.40)	(2.75)	(2.32)	(2.07)	(1.87)	(1.73)	(1.61)	(1.50)	(1.42)	(1.25)	(1.13)	(1.05)	(0.99)
3/4	0.824	360	250	200	170	151	138	125	118	110	103	93	84	77	72
	(21)	(10.2)	(7.08)	(5.66)	(4.81)	(4.28)	(3.91)	(3.54)	(3.34)	(3.11)	(2.92)	(2.63)	(2.38)	(2.18)	(2.04)
1	1.049	680	465	375	320	285	260	240	220	205	195	175	160	145	135
	(27)	(19.3)	(13.2)	(10.6)	(9.06)	(8.07)	(7.36)	(6.80)	(6.23)	(5.80)	(5.52)	(4.96)	(4.53)	(4.11)	(3.82)
1 1/4	1.380	1400	950	770	660	580	530	490	460	430	400	360	325	300	280
	(35)	(39.6)	(26.9)	(21.8)	(18.7)	(16.4)	(15.0)	(13.9)	(13.0)	(12.2)	(11.3)	(10.2)	(9.20)	(8.50)	(7.93)
1 1/2	1.610	2100	1460	1180	990	900	810	750	690	650	620	550	500	460	430
	(41)	(59.5)	(41.3)	(33.4)	(28.0)	(25.5)	(22.9)	(21.2)	(19.5)	(18.4)	(17.6)	(15.6)	(14.2)	(13.0)	(12.2)
2	2.067	3950	2750	2200	1900	1680	1520	1400	1300	1220	1150	1020	950	850	800
	(53)	(112)	(77.9)	(62.3)	(53.8)	(47.6)	(43.0)	(39.6)	(36.8)	(34.5)	(32.6)	(28.9)	(26.9)	(24.1)	(22.7)
2 1/2	2.469	6300	4350	3520	3000	2650	2400	2250	2050	1950	1850	1650	1500	1370	1280
	(63)	(178)	(123)	(99.7)	(85.0)	(75.0)	(68.0)	(63.7)	(58.0)	(55.2)	(52.4)	(46.7)	(42.5)	(38.8)	(36.2)
3	3.068	11000	7700	6250	5300	4750	4300	3900	3700	3450	3250	2950	2650	2450	2280
	(78)	(311)	(218)	(177)	(150)	(135)	(122)	(110)	(105)	(97.7)	(92.0)	(83.5)	(75.0)	(69.4)	(64.6)
4	4.026	23000	15800	12800	10900	9700	8800	8100	7500	7200	6700	6000	5500	5000	4600
	(102)	(651)	(447)	(362)	(309)	(275)	(249)	(229)	(212)	(204)	(190)	(170)	(156)	(142)	(130)

- Determine the required Cu. Ft. / Hr. by dividing the rated heater input by 1000.
- FOR NATURAL GAS: Select the pipe size directly from the table.
- FOR PROPANE GAS: Multiply the Cu. Ft. / Hr. value by 0.633; then use the table.
- Refer to the metric conversion factors listed in General Safety section for SI unit measurements/conversions.

PIPE INSTALLATION

1. Install the gas piping in accordance with applicable local codes.
2. Check gas supply pressure. Each duct furnace must be connected to a manifold pressure and a gas supply capable of supplying its full rated capacity as specified in Table 6. A field LP tank regulator must be used to limit the supply pressure to maximum of 14 inch WC (3.5 kPa). All piping should be sized in accordance with the latest edition of ANSI Standard Z223.1 National Fuel Gas Code; in Canada, according to CSA B149. See Tables 1 and 5 for correct gas supply piping size. If gas pressure is excessive on natural gas applications, install a pressure regulating valve in the line upstream from the main shutoff valve.
3. Adequately support the piping to prevent strain on the gas manifold and controls.
4. To prevent the mixing of moisture with gas, run the take-off piping from the top, or side, of the main.
5. Standard gas duct furnaces and optional two-stage units are supplied with a combination valve which includes:
 - a. Manual "A" valve
 - b. Manual "B" valve
 - c. Solenoid valve
 - d. Pilot safety
 - e. Pressure regulator
 Pipe directly in to combination valve (see Figure 14).
6. A 1/8 inch NPT plugged tapping, accessible for test gauge connection, must be installed immediately upstream of the gas supply connection to the appliance.
7. Provide a drip leg in the gas piping near the gas duct furnace. A ground joint union and a manual gas shutoff valve should be installed ahead of the unit heater controls to permit servicing. The manual main shutoff valve must be located external to the jacket. See Figure 14.
8. Make certain that all connections have been adequately doped and tightened.

▲ CAUTION Do not over-tighten the inlet gas piping into the valve. This may cause stresses that would crack the valve!

NOTICE: Use pipe joint sealant resistant to the action of liquefied petroleum gases regardless of gas conducted.

▲ WARNING Check all pipe joints for leakage using a soap solution or other approved method. Never use an open flame or severe personal injury or death may occur.

Figure 14 - Pipe Installation, Standard controls

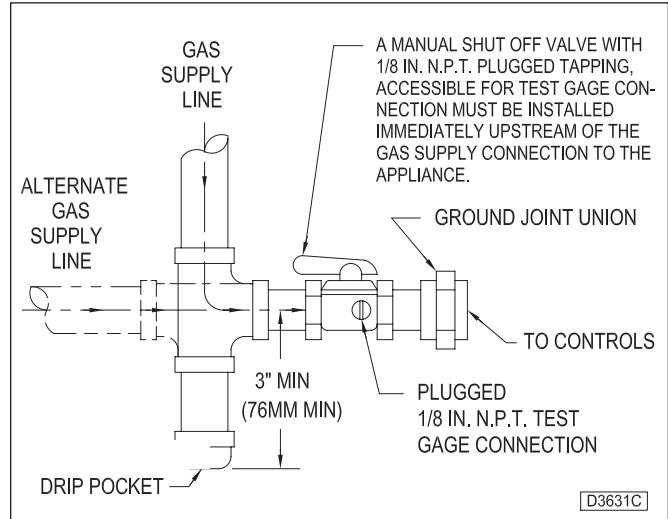

▲ WARNING Never use an open flame to detect gas leaks. Explosive conditions may exist which would result in personal injury or death.

The appliance and its individual shutoff valve must be disconnected from the gas supply piping system during any pressure testing of that system at test pressures in excess of 1/2 psi (3.5 kPa).

The appliance must be isolated from the gas supply piping system by closing its individual manual shutoff valve during any pressure testing of the gas supply piping system at test pressures equal to or less than 1/2 psi (3.5 kPa).

Table 6 - Gas Piping Requirements

SINGLE STAGE GAS PIPING REQUIREMENTS*		
GasType	Natural Gas	Propane (LP) Gas
Manifold Pressure	3.5 inch WC (0.9 kPa)	10.0 inch WC (2.5 kPa)
Supply Inlet Pressure	14.0 inch WC Maximum (3.5 kPa)	14.0 inch WC Maximum (3.5 kPa)
	5.0 inch WC Minimum (1.2 kPa)	11.0 inch WC Minimum (2.7 kPa)

*For single stage application only at normal altitudes.

TWO STAGE GAS PIPING REQUIREMENTS**		
Gas Type	Natural Gas	Propane (LP) Gas
Supply Inlet Pressure	6.5 inch WC Minimum (1.6 kPa)	11.5 inch WC Minimum (2.9 kPa)

**For two stage applications only at normal altitudes.

OPERATION

POWER VENTED DUCT FURNACES WITH INTERMITTENT (SPARK) PILOT IGNITION

▲ WARNING It is the installer's responsibility to check all safety controls! Check and test the operational functions of all safety devices supplied with this unit, and ensure that all are operating effectively. Failure to do so could result in unsafe conditions and may result in death, serious injury or property damage.

EXPLANATION OF CONTROLS:

1. The duct furnace is equipped with a dual automatic gas valve and electric ignition device (separate from the gas valve on most models) which provide the following functions:
 - a. The duct furnace is equipped with a power vent system consisting of a power venter motor and blower, pressure switch, and sealed flue collector in place of the conventional draft diverter.

▲ CAUTION Never operate the unit beyond the specified limits, severe damage to, and/or premature failure of the unit will result!

- b. The power venter motor is energized by the room thermostat on a call for heat. The pressure switch measures the flow through the vent system and energizes the indirect spark ignition system when the flow is correct.

▲ WARNING The pressure switch **MUST NOT** be bypassed. The unit **MUST NOT** be fired unless the power venter is operating. An unsafe condition could result.

▲ CAUTION The addition of external draft hoods or power venters is not permitted. Addition of such devices may cause serious unit malfunction or failure or possible personal injury.

- c. The intermittent pilot ignition system consists of an ignition control module, a dual combination gas valve, and a spark-ignited pilot burner. When the pressure switch closes, the pilot valve opens and a spark is generated to light the pilot burner. When the flame sensing circuit senses that pilot flame is established, the main gas valve is opened to supply gas to the main burners. When the thermostat is satisfied, the vent system is de-energized and both valves are closed to stop all flow of gas to the unit.
 - d. Pilot solenoid valve also functions as a main gas valve to provide redundancy.
 - e. Pressure regulator provides proper and steady gas pressure to the main burners.
 - f. Manual shutoff valve for service and long term shut-down. (Separate from the automatic valve on some models.)

2. The high limit switch interrupts the flow of electric current to the main gas valve in case the heater becomes overheated.
3. The fan switch delays the operation of the fan until the heater is warmed, then keeps the fan running after the gas has been turned off until the useful heat has been removed. **The start-up fan delay must not exceed 90 seconds from a cold start.**
4. The wall thermostat (supplied optionally) is a temperature sensitive switch which operates the vent system and ignition system; it turns the main gas valve ON or OFF to control the temperature of the space being heated. It must be mounted on a vibration free, vertical surface away from air currents, in accordance with the instructions furnished with the thermostat (also refer to Electrical Section).

START-UP

1. Open the manual valve supplying gas to the unit heater, and with the union connection loose, purge air from the gas line. Tighten the union and check for gas leaks, using a soapy water solution only.

▲ WARNING Never use an open flame to detect gas leaks. Explosive conditions may exist which would result in personal injury or death.

▲ WARNING Before attempting to light or relight pilot, wait 5 minutes to allow gas which may have accumulated in the burner compartment to escape. Failure to do so could cause the accumulated gas to ignite rapidly, leading to personal injury or death.

2. Open the manual valve on the unit heater.
3. Turn ON electrical power.
4. The unit should be under the control of the thermostat. Turn the thermostat to the highest point and determine that the power venter motor starts and the pilot and main burners ignite. Turn the thermostat to the lowest point and determine that the power venter motor shuts off and pilot and main burners are extinguished.
5. If pilot adjustment is required, remove the pilot adjustment seal cap and adjust the pilot screw to obtain proper flame. Clockwise rotation decreases pilot flame size. Replace the cap.
6. Turn the thermostat to the desired position.
7. Refer to "Adjustments" section for more specifications.

SHUT DOWN

1. Turn the valve selector knob to the "OFF" position.
2. Turn off the electricity.
3. To relight, follow the "start-up" instructions.

See Figure 15 for burner component parts/identification.

Figure 15 - Burner Components — Intermittent Pilot Ignition
Also refer to Figures 1 and 2 and 17 thru 19 for component locations.

Burner Drawer Common Parts:

1. Main Burners
2. Burner Manifold
3. Air Shutters
4. Burner Springs
5. Main Burner Orifice
6. Transformer
7. Pilot Tubing

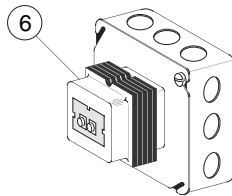
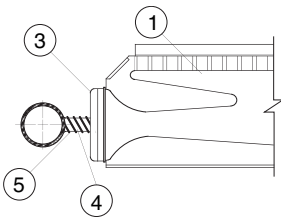
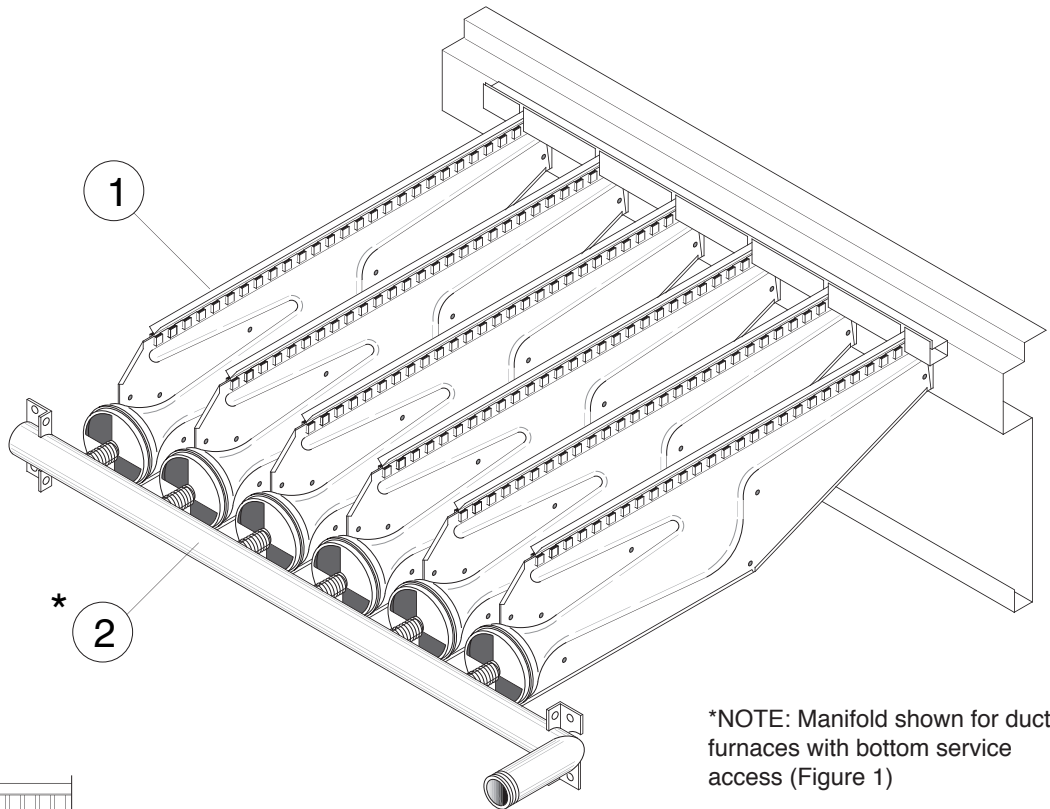

Controls:

- 8A. Main Gas Valve (Honeywell)
- 8B. Main Gas Valve (White Rodgers)
9. Honeywell Ignitor
10. Honeywell Pilot Burner
11. Honeywell Pilot Orifice
13. High Limit
 (Located on the Rear Header Plate of the Heat Exchanger - Air Inlet Side)

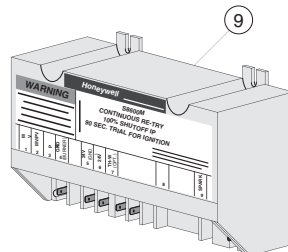
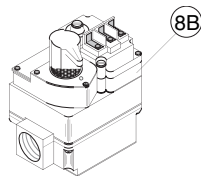
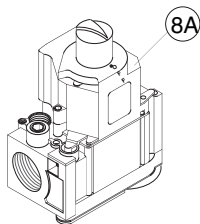
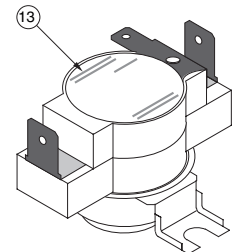
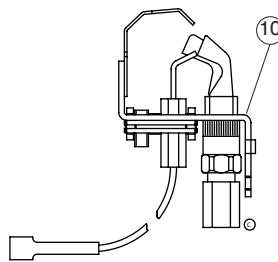
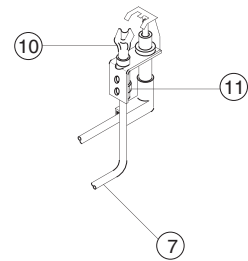

GAS INPUT RATE

▲ CAUTION Never overfire the duct furnace, as this may cause unsatisfactory operation or shorten the life of the heater.

Check the gas input rate as follows (Refer to general safety section for metric conversions/SI units):

1. Turn off all gas appliances that use gas through the same meter as the heater.
2. Turn gas on to the heater.
3. Clock the time in seconds required to burn one cubic foot of gas by checking the gas meter.
4. Insert the time required to burn one cubic foot of gas into the following formula and compute the input rate.

$$\frac{3600 \text{ (Sec. Per Hr.)} \times \text{Btu/Cu. Feet}}{\text{Time (Sec.)}} = \text{Input Rate}$$

For example, assume the Btu content of one cubic foot of gas equalled 1000 and that it takes 18 seconds to burn one cubic foot of gas.

$$\frac{3600 \times 1000}{18} = 200,000$$

NOTICE: If the computation exceeds or is less than 95 percent of the gas Btu/hr. input rating (see “Specifications”), adjust the gas pressure.

Adjust the gas pressure as follows:

1. **NATURAL GAS:** Best results are obtained when the heater is operating at its full input rating with the manifold pressure of 3.5 inches WC (0.9 kPa). Adjustment of the pressure regulator is not normally necessary since it is preset at the factory.

However, field adjustment may be made as follows:

- a. Attach manometer at pressure tap plug adjacent to control outlet.
 - b. Remove regulator adjustment screw cap, located on combination gas valve.
 - c. With a small screwdriver, rotate the adjustment screw counterclockwise to decrease or clockwise to increase pressure. Do not force beyond stop limits.
 - d. Replace regulator adjustment screw cap.
2. **PROPANE GAS:** An exact manifold pressure of 10.0 inches WC (2.5 kPa) must be maintained for proper operation of the heater. If the unit is equipped with a pressure regulator on the combination gas valve, follow steps “a” through “d” above. If the unit is not so equipped, the propane gas supply system pressure must be regulated to attain this manifold operating pressure.

TABLE 7 - Main Burner Orifice Schedule*

* INPUT IN 1000 BTU	TYPE OF GAS	NATURAL	PROPANE	NO. OF BURNER ORIFICES
	HEATING VALUE	1075 BTU/Ft ³ (40.1 MJ/m ³)	2500 BTU/Ft ³ (93.1 MJ/m ³)	
	MANIFOLD PRESSURE	3.5" W.C. (0.9 kPa)	10.0" W.C. (2.5 kPa)	
100	FT ³ /HR ORIFICE DRILL	96 42	40 54	4
125	FT ³ /HR ORIFICE DRILL	120 42	50 54	5
150	FT ³ /HR ORIFICE DRILL	140 42	60 54	6
175	FT ³ /HR ORIFICE DRILL	163 42	70 54	7
200	FT ³ /HR ORIFICE DRILL	186 42	80 54	8
225	FT ³ /HR ORIFICE DRILL	210 42	90 54	9
250	FT ³ /HR ORIFICE DRILL	233 42	100 54	10
300	FT ³ /HR ORIFICE DRILL	280 42	120 54	12
350	FT ³ /HR ORIFICE DRILL	326 42	140 54	14
400	FT ³ /HR ORIFICE DRILL	372 42	160 54	16

* This schedule is for units operating at normal altitudes of 2000 feet (610m) or less. SPECIAL ORIFICES ARE REQUIRED FOR INSTALLATIONS ABOVE 2000 feet (610M).

When installed in Canada, any references to deration at altitudes in excess of 2000 feet (610m) are to be ignored. At altitudes of 2000 to 4500 feet (610 to 1372m), the unit heaters must be orificed to 90% of the normal altitude rating, and be so marked in accordance with the ETL certification.

PRIMARY AIR SHUTTER ADJUSTMENT

After the unit has been operating for at least 15 minutes, adjust the primary air flow to the burners. Turn the friction-locked, manually-rotated air shutters clockwise to close, or counterclockwise to open.

For correct air adjustment, close the air shutter until yellow tips in the flame appear. Then open the air shutter to the point just beyond the position where yellow tipping disappears. Refer to Figure 16.

NOTICE: There may be momentary and spasmodic orange flashes in the flame. This is caused by the burning of airborne dust particles, and not to be confused with the yellow tipping, which is a stable or permanent situation when there is insufficient primary air.

Figure 16 - Main Burner Flames

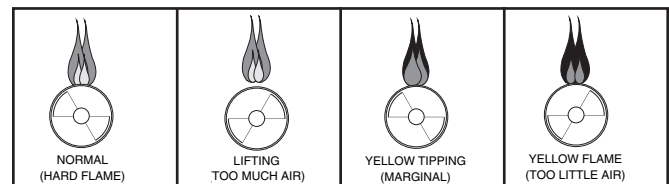

PILOT ADJUSTMENT

1. Remove the pilot adjustment cap.
2. Adjust the pilot screw to provide a properly sized flame.
3. A proper pilot flame is a soft steady flame that envelops 3/8 to 1/2-inch (9.5 to 12.7 mm) of the flame sensor tip.
4. Replace the pilot adjustment cap.

MANIFOLD PRESSURE ADJUSTMENT

If the manifold pressure requires minor adjustment, remove the cap from the pressure regulator and turn the adjustment screw clockwise to increase the pressure, or counterclockwise to decrease the pressure. The adjusted manifold pressure should not vary more than 10 percent from the pressures specified in Table 7.

MAINTENANCE

PERIODIC SERVICE

▲ WARNING Open all disconnect switches and secure in that position before servicing unit. Failure to do so may result in personal injury or death from electrical shock.

▲ WARNING Gas tightness of the safety shut-off valves must be checked on at least an annual basis.

To check gas tightness of the safety shut-off valves, turn off the manual valve upstream of the appliance combination control. Remove the 1/8 inch pipe plug on the inlet side of the combination control and connect a manometer to that tapping. Turn the manual valve on to apply pressure to the combination control. Note the pressure reading on the manometer, then turn the valve off. A loss of pressure indicates a leak. If a leak is detected, use a soap solution to check all threaded connections. If no leak is found, combination control is faulty and must be replaced before putting appliance back in service.

NOTICE: The heater and vent system should be checked once a year by a qualified technician.

▲ WARNING It is the service technician's responsibility to check all safety controls! Check and test the operational functions of all safety devices supplied with this unit, and ensure that all are operating effectively. Failure to do so could result in unsafe conditions and may result in death, serious injury or property damage.

All Maintenance/Service info should be recorded accordingly on the Inspection Sheet provided on back cover of this manual. Should maintenance be required, perform the following inspection and service routine:

1. Inspect the area near the unit to be sure that there is no combustible material located within the minimum clearance requirements listed in the "Installation" section and in Table 3.

▲ WARNING Under no circumstances should combustible material be located within the clearances specified in this manual. Failure to provide proper clearance could result in personal injury or equipment damage from fire.

2. Turn off the manual gas valve and electrical power to the gas duct furnace.
3. To clean or replace the main burners, remove the bottom panel or slide out the pullout drawer, and compress the spring by moving the burner toward the manifold. Slide the opposite end of the burner downward from the locating slot while retaining spring is still compressed. Pull the burners away from the manifold.
4. With the burners removed, wire brush the inside surfaces of the heat exchanger.
5. Remove any dirt, dust, or other foreign matter from the burners using a wire brush and/or compressed air. Ensure that all parts are unobstructed. Inspect and clean pilot burner if necessary.
6. Reassemble the gas duct furnace by replacing all parts in reverse order.
7. Complete the appropriate unit start-up procedure as given in the "Operation" section of this manual (see lighting instruction plate on the access side of the unit).
8. Check the burner adjustment. See the "Primary Air Shutter Adjustment" section of this manual.
9. Check all gas control valves and pipe connections for leaks.
10. Check the operation of the automatic gas valve by lowering the setting of the thermostat, stopping the operation of the gas duct furnace. The gas valve should close tightly, completely extinguishing the flame on the main burners.
11. Check the operation of the pilot safety device by closing the pilot line valve, extinguishing the pilot flame. Within one minute the automatic gas valve should close, extinguishing the flame on the main burners.
12. Inspect and service the blower section of the system.
13. Check and test the operational functions of all safety devices supplied with your unit.

DUCT FURNACE COMPONENTS (Power Vented)

Figure 17 - Duct Furnace Components

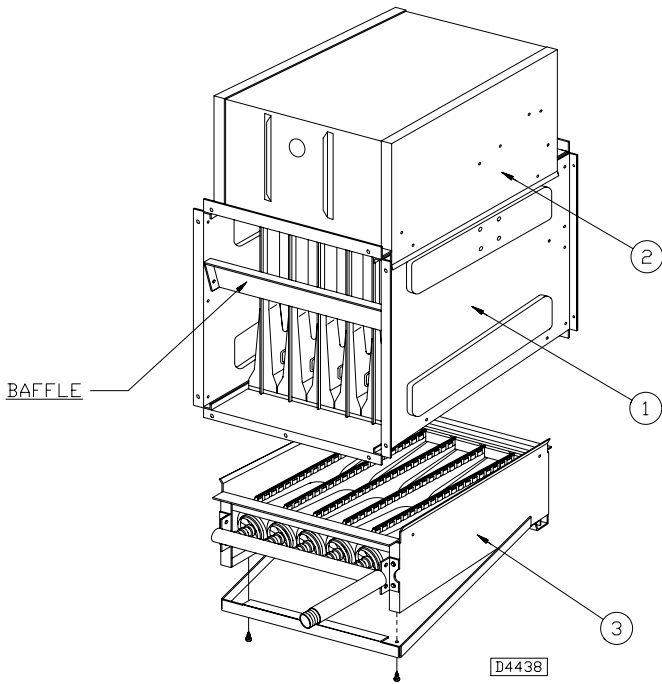

Figure 18 - Burners/Controls (Bottom View)

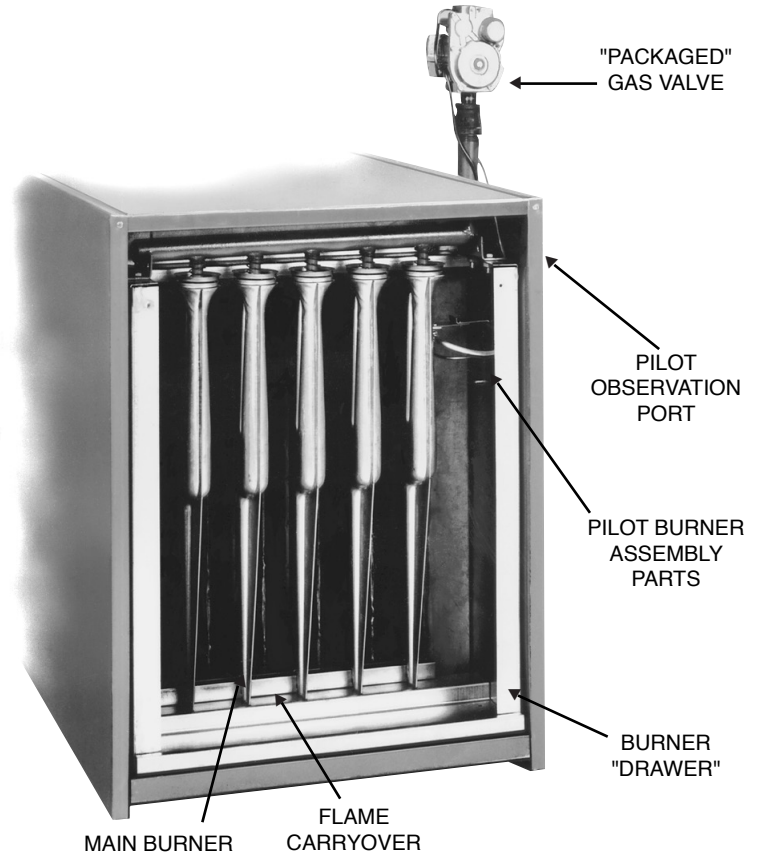
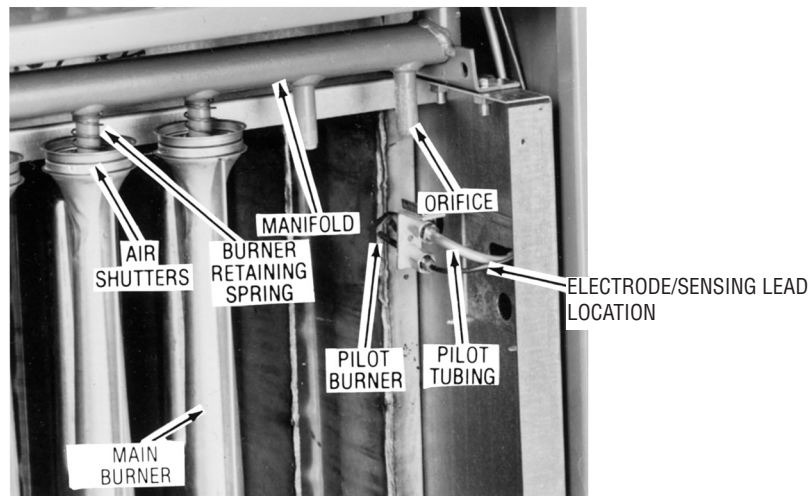
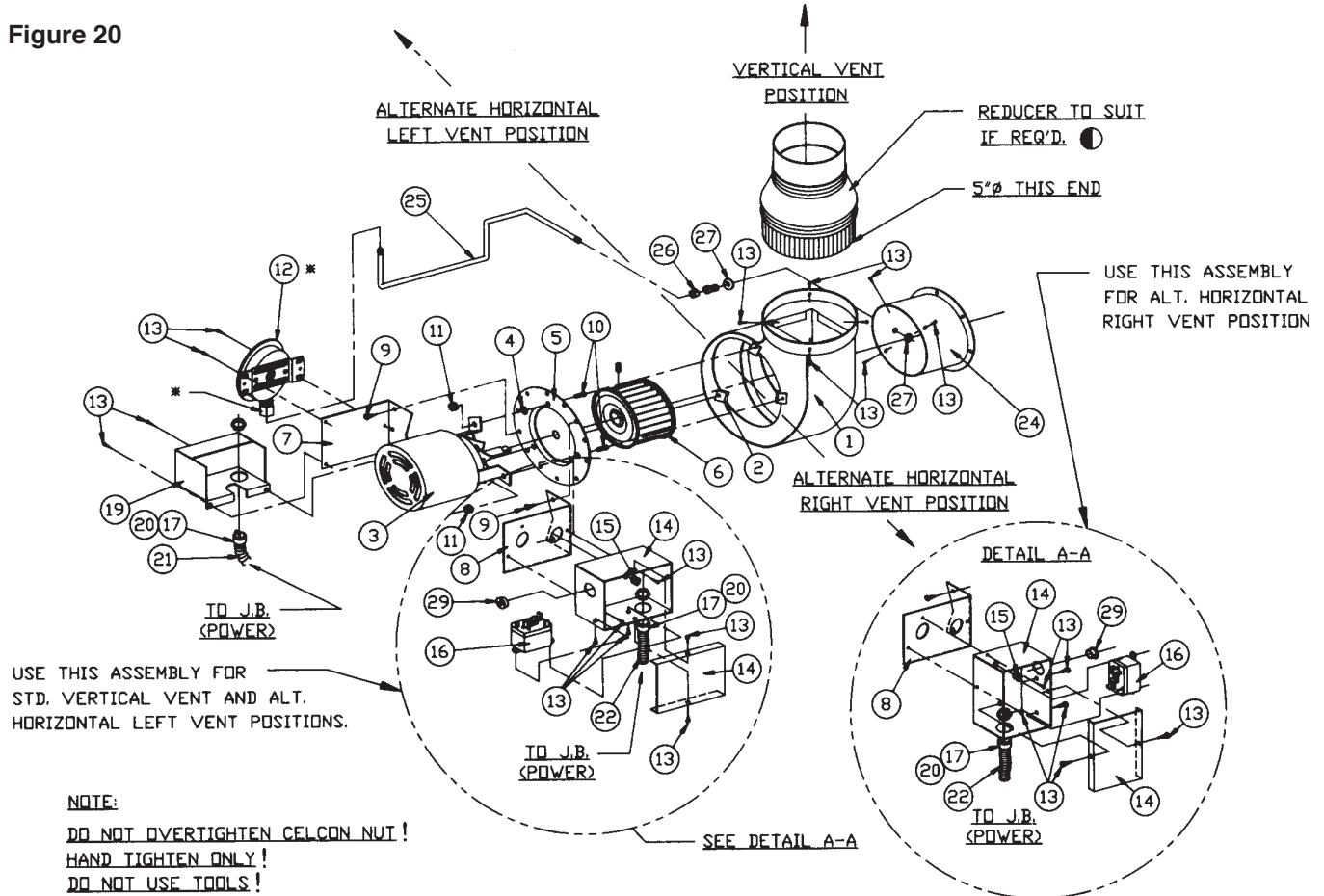

Figure 19 - Burner Assembly Parts (Bottom View)



POWER VENTER ASSEMBLY (Power Vented Duct Furnaces Only)

Figure 20



REF. NO.	DESCRIPTION
1	BLOWER HOUSING ASSEMBLY
2	SPEED NUT
3	MOTOR
4	WASHER, PLAIN
5	PLATE ADAPTOR
6	BLOWER WHEEL
7	MOUNTING BRACKET (PRESSURE SWITCH)
8	MOUNTING BRACKET (JUNCTION BOX)
9	SCREW, S.T.
10	SCREW, MACHINE (L = 3/4 INCH)
11	NUT, KEPS (EXT. LOCKWASHER)
12	AIR PRESSURE SWITCH
13	DRILL SCREW
14	JUNCTION BOX ASSEMBLY

REF. NO.	DESCRIPTION
15	SNAP BUSHING
16	RELAY
17	STRAIGHT CONNECTOR
19	SHIELD (PRESSURE SWITCH)
20	ANTI-SHORT
21	FLEX CONDUIT (23 INCH LONG)
22	FLEX CONDUIT (24 INCH LONG)
23	SLOTTED HEAD MACHINE SCREW, (L = 7/8 INCH)
24	DRAFTOR STACK ASSEMBLY
25	1/4 INCH ALUMINUM TUBING
26	MALE CONNECTOR
27	LOCKNUT
28	NUT, KEPS (EXT. LOCKWASHER)
29	7/8 INCH PLUG

SEE FIGURES 1, 2, 8, 11, 12, 13 AND TABLE 1 FOR USAGE.

INSTALLATION INSTRUCTIONS FOR FIELD REPLACEMENT OF POWER VENTER MOTOR

▲ WARNING Never service any compartment without first disconnecting all electrical and gas supplies. Refer to unit's wiring diagram. This replacement must be performed only by a qualified technician.

NOTICE: All hardware (screws, nuts, washers) that will be removed from the unit will be reused for this motor replacement. **DO NOT LOSE ANY OF THESE PARTS.**

Figure 21 - Identification of Parts

REF. NO.	DESCRIPTION
1	Relay Junction Box/Mounting Bracket Assembly
2	#8 Drill Screws (2 required)
3	Pressure/Mounting Bracket Assembly
4	Mounting Plate Adapter
5	Keeps Nut w/External Tooth Lockwasher (4 required)
6	Motor Support Shipping Bracket
7	Phillips Head Screws (3 required)
8	Power Venter Blower Housing
9	Blower Wheel
10	Motor
11	Space Washers (3 required)
12	Machine Screw (3 required)
13	Sensing Tube
14	Set Screw

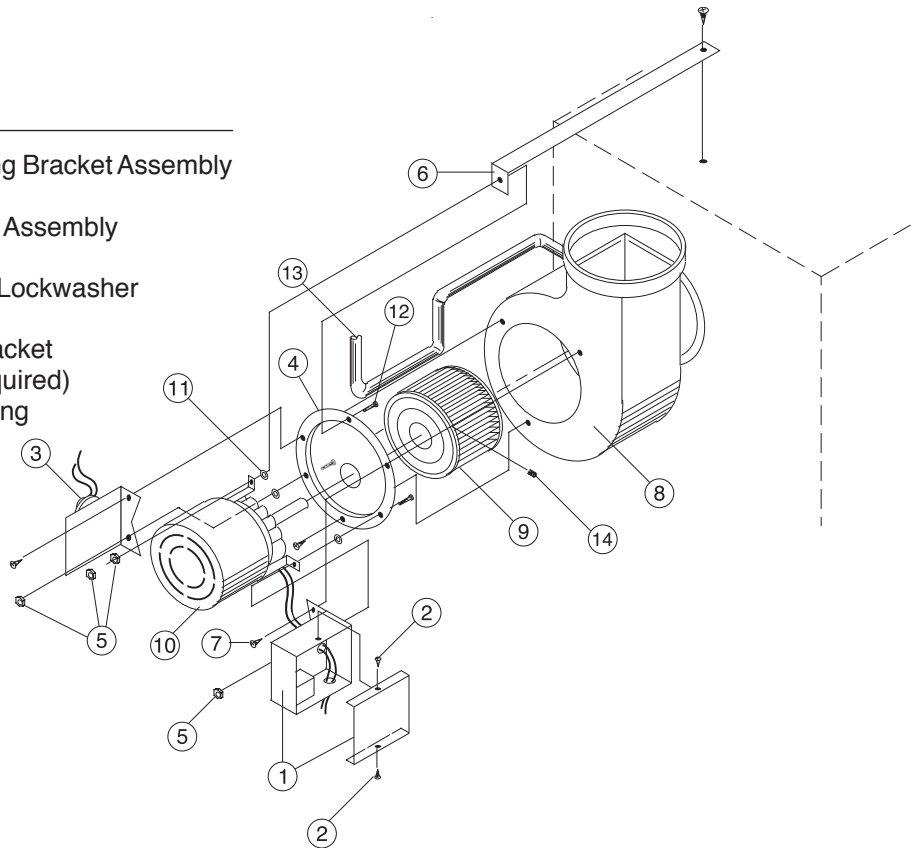

TOOLS AND PARTS NEEDED:

Wire Stripper and Crimper; Slotted Head and #2 Phillips Head Screwdriver; 3/8 inch Wrench; 1/8 inch Allen Wrench (long handle); marker; (1) 1/4 inch push on terminal for Wire.

NOTES:

- 1) Remove the cover from the Relay Junction Box (Item 1) by removing two screws (Item 2) top and bottom. Disconnect both wires from the motor lead ends. One is connected to terminal #4 on the venter relay, and the other is connected with a wire nut to a black wire.
- 2) Remove the sensing tube (Item 3) from the Pressure Switch/Mounting Bracket (Item 3) at motor end only. Separated Combustion Units: Remove both tubes at motor end only - note location.
- 3) Mark locations of the Relay Junction Box and Pressure Switching Mounting Brackets along with the Motor (Item 10) mounts on the Mounting Adaptor Plate (Item 4) - using a marker.

- 4) Remove nut (Item 5) that secures the Motor Support Shipping Bracket (Item 6) to the Mounting Adaptor Plate. Pull this bracket away from the Motor Mounting Adaptor Plate.
- 5) Remove three phillips head screws (Item 7) on the Motor mounting Adaptor Plate. Remove the Motor/ Blower Wheel/Adaptor Plate assembly from the Power Venter Blower Housing (Item 8).
- 6) Remove the Blower Wheel (Item 9) from the motor shaft - by removing the set screw (Item 14) using a 1/8" Allen Wrench.
- 7) Remove the three Motor Mounting Nuts (Item 5), Space Washers (Item 11), and Screws (Item 12). Do not lose these parts! Using caution - the motor will disengage from the Mounting Adaptor Plate, along with the Relay Junction Box and Pressure Switch Mounting Brackets will also disengage
- 8) Reverse order to install the new Power Venter Motor.
- 9) **TEST FIRE THE UNIT FOR A FEW CYCLES, MAKING SURE THAT THE UNIT IS OPERATING SATISFACTORY.**

Troubleshooting Guide

Table 8

SYMPTOMS	POSSIBLE CAUSE(S)	CORRECTIVE ACTION
A. Flame lifting from burner ports.	<ol style="list-style-type: none"> 1. Pressure regulator set too high. 2. Defective Regulator. 3. Burner orifice too large. 	<ol style="list-style-type: none"> 1. Reset manifold pressure. Refer to "Operation". 2. Replace regulator section of combination gas valve or complete valve. 3. Check with local gas supplier for proper orifice size and replace. Refer to "Operation".
B. Flame pops back.	<ol style="list-style-type: none"> 1. Excessive primary air. 2. Burner orifice too small. 	<ol style="list-style-type: none"> 1. Close air shutter. Refer to "Operation". 2. Check with local gas supplier for proper orifice size and replace. Refer to "Operation".
C. Noisy flame.	<ol style="list-style-type: none"> 1. Too much primary air. 2. Noisy pilot 3. Irregular orifice causing whistle or resonance. 4. Excessive gas input. 	<ol style="list-style-type: none"> 1. Close air shutter. 2. Reduce pilot gas. Refer to "Operation". 3. Replace orifice. 4. Reset manifold pressure. Refer to "Operation"; Replace regulator section of combination gas valve or complete valve; or Check with local gas supplier for proper orifice size and replace. Refer to "Operation".
D. Yellow tip flame (some yellow tipping on propane gas is permissible).	<ol style="list-style-type: none"> 1. Insufficient primary air. 2. Clogged main burner ports. 3. Misaligned orifices. 4. Clogged draft hood. 5. Air shutter linted. 6. Insufficient combustion air. 	<ol style="list-style-type: none"> 1. Open air shutters. Refer to "Operation". 2. Clean main burner ports. 3. Replace manifold assembly. 4. Clean draft hood. 5. Check for dust or lint at air mixer opening and around the air shutter. 6. Clean combustion air inlet openings in bottom panel, see "Installation".
E. Floating flame.	<ol style="list-style-type: none"> 1. Blocked venting. 2. Insufficient combustion air. 3. Blocked heat exchanger. 4. Air leak into combustion chamber or draft hood. 	<ol style="list-style-type: none"> 1. Clean flue. Refer to "Installation". 2. Clean combustion air inlet openings in bottom panel, see "Installation". 3. Clean heat exchanger. 4. Determine cause and repair accordingly.
F. Gas Odor.	<ol style="list-style-type: none"> 1. Shut off gas supply immediately! 2. Blocked heat exchanger/venting. 3. Drafts around heater. 4. Negative Pressure in building. 5. Blocked draft hood. 	<ol style="list-style-type: none"> 1. Inspect all gas piping and repair. 2. Clean heat exchanger/flue. 3. Eliminate drafts. Refer to "Installation". 4. See "Installation". 5. Clean draft hood.
G. Delayed ignition.	<ol style="list-style-type: none"> 1. Excessive primary air. 2. Main burner ports clogged near pilot. 3. Pressure regulator set too low. 4. Pilot decreases in size when main burners come on. 5. Pilot flame too small. 6. Drafts around heater. 7. Improper venting. 	<ol style="list-style-type: none"> 1. Close air shutter. Refer to "Operation". 2. Clean main burner ports. 3. Reset manifold pressure. Refer to "Operation". 4. Supply piping is inadequately sized. Refer to "Installation". 5. Clean pilot orifice. Refer to "Operation". 6. Eliminate drafts. Refer to "Installation". 7. Refer to "Installation".
H. Failure to ignite.	<ol style="list-style-type: none"> 1. Main gas off. 2. Lack of power at unit. 3. Thermostat not calling for heat. 4. Defective limit switch. 5. Improper thermostat or transformer wiring at gas valve. 	<ol style="list-style-type: none"> 1. Open all manual gas valves. 2. Replace fuse or turn on power supply. 3. Turn up thermostat 4. Check limit switch with continuity tester. If open, replace limit switch. 5. Check wiring per diagrams.

Troubleshooting Guide

SYMPTOMS	POSSIBLE CAUSE(S)	CORRECTIVE ACTION
H. Failure to ignite. <i>continued</i>	<ul style="list-style-type: none"> 6. Defective gas valve. 7. Defective thermostat 8. Defective transformer. 9. Loose wiring. 10. Defective ignition control. 	<ul style="list-style-type: none"> 6. Replace gas valve. 7. Check thermostat and replace if defective. 8. Be sure 115 volts is supplied to the transformer primary, then check for 24 volts at secondary terminal before replacing. 9. Check and tighten all wiring connections per diagrams. 10. Replace, if necessary. Also see W, X & Y symptoms.
J. Condensation of water vapor.	<ul style="list-style-type: none"> 1. Improper venting. 	<ul style="list-style-type: none"> 1. Refer to "Installation, Venting".
K. Burner won't turn off.	<ul style="list-style-type: none"> 1. Poor thermostat location. 2. Defective thermostat 3. Improper thermostat or transformer wiring at gas valve. 4. Short circuit. 5. Defective or sticking gas valve. 6. Excessive gas supply pressure. 	<ul style="list-style-type: none"> 1. Relocate thermostat away from drafts. 2. Replace thermostat. 3. Check wiring per diagrams. 4. Check operation at valve. Look for short (such as staples piercing thermostat wiring), and correct. 5. Replace gas valve. 6. Refer to "Operation".
L. Rapid burner cycling.	<ul style="list-style-type: none"> 1. Loose electrical connections at gas valve or thermostat. 2. Excessive thermostat heat anticipator. 3. Unit cycling on high limit. 4. Poor thermostat location. 5. Draft on Pilot. 6. Defective ignitor control (if applicable). 7. Unit cycling on high limit. 8. Defective high limit switch. 	<ul style="list-style-type: none"> 1. Tighten all electrical connections. 2. Adjust thermostat heat anticipator for longer cycles. Refer to "Operation". 3. Check for proper air supply across heat exchanger. 4. Relocate thermostat. (Do not mount thermostat on unit). 5. Eliminate drafts. Refer to Installation. 6. Replace ignitor. 7. Check for proper air supply across heat exchanger. 8. Jumper limit switch terminals 1 and 2. If burner operates normally, replace switch.
M. Noisy power venter.	<ul style="list-style-type: none"> 1. Power venter wheel loose. 2. Power venter wheel dirty. 3. Power venter wheel rubbing housing. 4. Bearings are dry. 	<ul style="list-style-type: none"> 1. Replace or tighten. 2. Clean power venter wheel. 3. Realign power venter wheel. 4. Oil bearings on power venter motor. (Refer to label on motor).
N. Pilot will not light or will not stay lit.	<ul style="list-style-type: none"> 1. Main gas off. 2. Pilot adjustment screw turned too low on combination/automatic main gas valve. 3. Air in gas line. 4. Incorrect lighting procedure. 5. Dirt in pilot orifice. 6. Extremely high or low gas pressure. 	<ul style="list-style-type: none"> 1. Open all manual gas valves. 2. Increase size of pilot flame. Refer to "Operation". 3. Purge air from gas supply. 4. Follow lighting instruction label adjacent to gas valve. 5. Remove pilot orifice. Clean with compressed air or solvent. (Do not ream). 6. Refer to "Operation".

Troubleshooting Guide

SYMPTOMS	POSSIBLE CAUSE(S)	CORRECTIVE ACTION
N. Pilot will not light or will not stay lit. <i>continued</i>	<ol style="list-style-type: none"> 7. Defective thermocouple (Standing pilot units only). 8. Drafts around unit. 9. Pilot valve not opening (faulty wiring). 10. No spark (if applicable) (faulty wiring). 11. Defective gas valve. 	<ol style="list-style-type: none"> 7. Check thermocouple connection, and replace if defective. 8. Eliminate drafts. Refer to "Installation". 9. Inspect and correct all wiring. 10. Inspect and correct ignition system wiring. See symptoms W, X, & Y. 11. Replace.
O. Power venter will not run.	<ol style="list-style-type: none"> 1. Loose wiring. 2. Defective motor overload protector or defective motor. 3. Defective power venter relay. 	<ol style="list-style-type: none"> 1. Check and tighten all wiring connections per diagrams. Thermostat wires tagged "W" and "G" must be connected together (unless special thermostats are used; if so, see thermostat wiring diagram). See electrical connections. 2. Replace motor. 3. Check for 24V across 1 and 3 terminals on fan relay. If 24V is present, jumper terminals numbered 2 and 4. If motor runs, the relay is defective and must be replaced. If 24V is not present, check wiring per diagrams.
P. Power venter motor turns on and off while burner is operating.	<ol style="list-style-type: none"> 1. Fan relay heater element improperly wired. 2. Defective venter relay switch. 3. Motor overload protector cycling on and off. 4. Motor not properly oiled. 	<ol style="list-style-type: none"> 1. Be sure venter relay heater terminals are connected per diagrams. 2. Replace venter relay. 3. Check motor amps against motor name plate rating, check voltage, replace power venter motor if defective. 4. Refer to label on motor.
Q. Power Venter motor will not stop.	<ol style="list-style-type: none"> 1. Improperly wired venter relay. 2. Main burners not lighting while thermostat calls for heat. 3. Defective venter relay. 	<ol style="list-style-type: none"> 1. Check all wiring. 2. Refer to H & N symptoms. 3. Replace venter relay.
R. Not enough heat.	<ol style="list-style-type: none"> 1. Incorrect gas input. 2. Heater undersized. 3. Thermostat malfunction. 4. Heater cycling on limit control. 5. Check outside dampers if used. 	<ol style="list-style-type: none"> 1. Refer to "Operation". 2. This is especially true when the heated space is enlarged. Have the heat loss calculated and compare to the heater output (80% of input). Your gas supplier or installer can furnish this information. If heater is undersized, add additional heaters. 3. Replace thermostat. 4. Check air movement through heat exchanger. Check voltage to fan motor. Clean power venter blade and heat exchanger and oil power venter motor. 5. Adjust dampers accordingly.

Troubleshooting Guide

SYMPTOMS	POSSIBLE CAUSE(S)	CORRECTIVE ACTION
T. Too much heat.	<ol style="list-style-type: none"> 1. Thermostat malfunction. 2. Heater runs continuously. 	<ol style="list-style-type: none"> 1. Replace thermostat. 2. Check wiring per diagrams; Check operation at valve. Look for short (such as staples piercing thermostat wiring), and correct; Replace gas valve; Refer to "Operation".
U. Cold air is delivered on start up.	<ol style="list-style-type: none"> 1. Fan relay heater element improperly wired. 	<ol style="list-style-type: none"> 1. Be sure fan relay heater terminals are connected per diagrams.
V. Cold air is delivered during heater operation.	<ol style="list-style-type: none"> 1. Incorrect manifold pressure or input. 2. Voltage to unit too high. 3. Air through put too high. 	<ol style="list-style-type: none"> 1. Refer to "Operation". 2. Check motor voltage with fan running. Should be 115 volts AC. 3. Refer to "Operation".
W. NO Spark	<ol style="list-style-type: none"> 1. Thermostat not calling for heat. 2. No low voltage. 3. Spark gap closed or too wide. 4. Broken or cracked ceramic on spark electrode. 	<ol style="list-style-type: none"> 1. Close thermostat contacts. 2. Check for 24V across 24V terminals of S8600. 3. Set gap to 0.1". 4. Replace pilot assembly.
X. Spark present but pilot does not light.	<ol style="list-style-type: none"> 1. Loose S8600 connections. 2. Improper gas pressure. 3. Is spark in pilot gas stream? 4. No pilot gas — do not use match to test - presence of gas is easily detected by the odor. 	<ol style="list-style-type: none"> 1. Check all connections, terminal PV feeds 24V to pilot valve. 2. Check pressure — pressure that is either too high or too low may cause a problem. 3. Spark should arc from electrode. 4. Check pilot line for kinks. Ensure there are no drafts.
Y. Pilot lights — Main valve does not energize.	<ol style="list-style-type: none"> 1. Loose S8600 connections. 2. Cracked or broken sensor ceramic. 3. Check sensor/spark lead for continuity. 4. Measure 24 volts from terminal MV to terminal MV/PV. 	<ol style="list-style-type: none"> 1. Check connections-term. MV feeds main valve. 2. Replace pilot assembly. 3. Replace if needed. 4. If present, replace main valve; if not, replace S8600 Igniter.
Z. Hi-Limit switch tripping.	<ol style="list-style-type: none"> 1. Vertical run of flue is too short. (Standard unit only — as Catagory I) 2. Unit is overfiring. 3. Air flow too low 4. Defective switch. 	<ol style="list-style-type: none"> 1. Lengthen vertical run of flue pipe (see venting). 2. Manifold pressure is too high; adjust. Burner orifices may be too large: verify/replace if req'd. 3. Increase air flow; check fan size. Check for proper voltage. 4. Replace.

HOW TO ORDER REPLACEMENT PARTS

Please send the following information to your local representative. If further assistance is needed, contact the manufacturer's customer service department.

- Model number
- Serial Number (if any)
- Part description and Number as shown in the Replacement Parts Catalog.

LIMITED WARRANTY Gas-Fired Duct Furnaces

The "Manufacturer" warrants to the original owner at original installation site that the above models of the Duct Furnaces (the "Product") will be free from defects in material or workmanship for a period not to exceed one (1) year from startup or eighteen (18) months from the date of shipment from the factory, whichever occurs first. If upon examination by the Manufacturer the Product is shown to have a defect in material or workmanship during the warranty period, the Manufacturer will repair or replace, at its option, that part of the Product which is shown to be defective.

This limited warranty does not apply:

- (a) if the Product has been subjected to misuse or neglect, has been accidentally or intentionally damaged, has not been installed, maintained or operated in accordance with the furnished written instructions, or has been altered or modified in any way.
- (b) to any expenses, including labor or material, incurred during removal or reinstallation of the defective Product or parts thereof.
- (c) to any damage due to corrosion by chemicals (including halogenated hydrocarbons) precipitated in the air.
- (d) to any workmanship of the installer of the Product.

This limited warranty is conditional upon:

- (a) advising the installing contractor, who will in turn notify the distributor or manufacturer.
- (b) shipment to the Manufacturer of that part of the Product thought to be defective. Goods can only be returned with prior written approval of the Manufacturer. All returns must be freight prepaid.
- (c) determination in the reasonable opinion of the Manufacturer that there exists a defect in material or workmanship.

Repair or replacement of any part under this Limited Warranty shall not extend the duration of the warranty with respect to such repaired or replaced part beyond the stated warranty period.

THIS LIMITED WARRANTY IS IN LIEU OF ALL OTHER WARRANTIES, EITHER EXPRESS OR IMPLIED, AND ALL SUCH OTHER WARRANTIES, INCLUDING WITHOUT LIMITATION IMPLIED WARRANTIES OF MERCHANTABILITY OR FITNESS FOR A PARTICULAR PURPOSE, ARE HEREBY DISCLAIMED AND EXCLUDED FROM THIS LIMITED WARRANTY. IN NO EVENT SHALL THE MANUFACTURER BE LIABLE IN ANY WAY FOR ANY CONSEQUENTIAL, SPECIAL, OR INCIDENTAL DAMAGES OF ANY NATURE WHATSOEVER, OR FOR ANY AMOUNTS IN EXCESS OF THE SELLING PRICE OF THE PRODUCT OR ANY PARTS THEREOF FOUND TO BE DEFECTIVE. THIS LIMITED WARRANTY GIVES THE ORIGINAL OWNER OF THE PRODUCT SPECIFIC LEGAL RIGHTS. YOU MAY ALSO HAVE OTHER RIGHTS WHICH MAY VARY BY EACH JURISDICTION.

In the interest of product improvement, we reserve the right to make changes without notice.

POWER VENTED INDOOR DUCT FURNACE UNIT NUMBER DESCRIPTION

Digit	X	X	X	X	—	1	2	3	4	5	6	7	8	9	10	11	12	13	14	15	+
Item	Prefix					UT	CA			FT	FM	GT	IC	AL	GC	SV	MT	MS	AS		

(Internal use Only)

Digit #1, 2 - Unit Type [UT]

D2 - Power Vented Duct Furnace
D6 - Side Service Power Vented Duct Furnace

Digit #3, 4, 5 - Capacity [CA]

100 - 100,000 BTU/HR
125 - 125,000 BTU/HR
150 - 150,000 BTU/HR
175 - 175,000 BTU/HR
200 - 200,000 BTU/HR
225 - 225,000 BTU/HR
250 - 250,000 BTU/HR
300 - 300,000 BTU/HR
350 - 350,000 BTU/HR
400 - 400,000 BTU/HR

Digit #6 - Furnace Type [FT]

A - Right Side Access (Standard)
B - Left Side Access

Digit #7 - Heat Exchanger Construction Material [FM]

1 - Aluminized Steel
2 - 409 Stainless Steel
3 - 321 Stainless Steel

Digit #8 - Gas Type [GT]

N - Natural Gas
P - Propane Gas (LP)
K - Natural Gas w/100% Shutoff

Digit #9 - Ignition Control [IC]

2 - Spark Ignition

Digit #10 - Altitude [AL]

A - 0–1,999 ft.	J - 8,000–8,999 ft.
B - 2,000–2,999 ft.	K - 9,000–9,999 ft.
C - 3,000–3,999 ft.	L - 10,000–10,999 ft.
D - 4,000–4,999 ft.	M - 11,000–11,999 ft.
F - 5,000–5,999 ft.	N - Local Gas Supplier Derate
G - 6,000–6,999 ft.	P - Canadian High Altitude 2,000–4,500 ft.
H - 7,000–7,999 ft.	

Digit #11 - Gas Control [GC]

A - Single Stage
B - Two Stage
H - Electronic Modulation w/Room Sensing
J - Electronic Modulation w/Duct Sensing
K - Electronic Modulation w/Duct Sensing & Room Ovrd. Stat
L - Electronic Modulation w/External 4-20 mA Input
N - Electronic Modulation w/External 0-10 VDC Input

Digit #12 - Supply Voltage [SV]

1 - 115/1/60	5 - 230/3/60
2 - 208/1/60	6 - 460/3/60
3 - 230/1/60	7 - 575/3/60
4 - 208/3/60	Z - Special

Note: Supply Voltages [SV] 2-7 include field mounted step down transformer.

Digit #13 - Motor Type [MT]

0 - None/Not Applicable

Digit #14 - Motor Sizes [MS]

0 - None/Not Applicable

Digit #15 - Accessories [AS]

FACTORY INSTALLED

A8 - Input Derate	P4 - Terminal Block Wiring
K4 - Fan Time Delay	P6 - Summer/Winter Switch
K5 - Air Flow Prove Switch	S1 - 409 Stainless Steel Burners
	S3 - 409 Stainless Steel Flue Collector

† FIELD INSTALLED (AS-____)

† Field Installed Accessories are not included in the Unit Number. All Field Installed Accessories are entered as a separate line item using the catalog number which utilizes "AS" as a prefix. i.e: F1 becomes AS-F1.

A7 - High Pressure Regulator	H5 - Low Ambient Control
A7-1/2-1 - Regulator for 0.5-10 PSI	M2-1 - Vent Caps (4 inch) (Unit Capacity 100-175)
A7-3/8-1 - Regulator for 10-20 PSI	M2-2 - Vent Caps (5 inch) (Unit Capacity 200-250)
A7-5/16-1 - Regulator for 20-35 PSI	M2-3 - Vent Caps (6 inch) (Unit Capacity 300-400)
F1 - Single-Stage T675A Ductstat	M3-1 - Adaptors (5-4 inch) (Unit Capacity 100-175)
F2 - Two-Stage T678A Ductstat	P2 - Adjustable High Limit Switch
G1 - Single-Stage T87K Mercury Free Thermostat w/Subbase Kit	P3 - Adjustable Fan Switch
G2 - Single-Stage T87K Mercury Free Thermostat w/TG511A Guard Kit	P5 - 24V SPST Relay-Specify Purpose
G3 - Single-Stage T834N Mercury Free Thermostat w/Fan Switch	Q7 - Horizontal/Vertical Louvers
G6 - Locking Thermostat Cover	S4 - 409 Stainless Steel Drip Pan
G9 - Single-Stage T822K Mercury Free Thermostat	

NOTES

GAS EQUIPMENT START-UP

Customer _____ Job Name & Number _____

PRE-INSPECTION INFORMATION With power and gas off.

Type of Equip: Indoor Duct Furnace

Serial Number _____ Model Number _____

Name Plate Voltage: _____ Name Plate Amperage: _____

Type of Gas: Natural LP Tank Capacity _____ lbs. Rating: _____ BTU @ _____ °F
_____ kg _____ kw @ _____ °C

- Are all panels, doors, vent caps in place?
- Has the unit suffered any external damage? Damage _____
- Does the gas piping and electric wiring appear to be installed in a professional manner?
- Has the gas and electric been inspected by the local authority having jurisdiction?
- Is the gas supply properly sized for the equipment?
- Were the installation instructions followed when the equipment was installed?
- Have all field installed controls been installed?
- Do you understand all the controls on this equipment? **If not, contact your wholesaler or rep.**
(DO NOT START this equipment unless you fully understand the controls.)

GENERAL

With power and gas off.

- Make certain all packing has been removed.
- Tighten all electrical terminals and connections.
- Check all controls for proper settings.

GAS HEATING

With power and gas on.

- Inlet gas pressure. _____ inch WC or _____ kPa
- Pilot & main burner ignition.
- Manifold gas pressure. _____ inch WC or _____ kPa
- Check electronic modulation. Set at: _____
- Cycle and check all other controls not listed.
- Check operation of remote panel.
- Entering air temp. _____ °F or _____ °C
- Discharge air temp. (high fire) _____ °F. or _____ °C
- External static pressure _____ inch WC
- Cycle by thermostat or operating control.
- Combustion reading
Carbon Monoxide _____ PPM
Carbon Dioxide _____ %

Remarks: _____
