



SELF-SERVICE REFRIGERATED DISPLAY CASES (SELF-CONTAINED & REMOTE)

PN 54382

PLEASE NOTE THE FOLLOWING:

1. YOUR SPECIFIC MODEL NUMBER IS ON THE SERIAL LABEL ON CASE REAR (NEAR MAIN POWER SWITCH).
2. ILLUSTRATIONS SHOWN BELOW LIST "(L)" TO REFLECT VARYING CASE LENGTH DIMENSIONS.
3. CASES SHOWN REFLECT FULL & OPEN END PANELS / STRAIGHT OR ANGLED BASES. YOURS MAY DIFFER.
4. SEE "MODELS (AND THEIR RESPECTIVE CASE DIMENSIONS) LISTED IN THIS MANUAL" SECTION FOR ADDITIONAL INFORMATION REGARDING SPECIFIC CASE DIMENSIONS OF STANDARD MODELS AND CDRs.

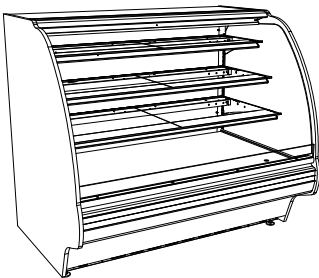

HV(L)56RSS
Angled Base - Full Ends

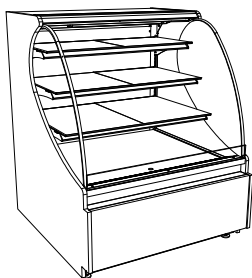

HV(L)RSS
Straight Base
Cutaway Ends

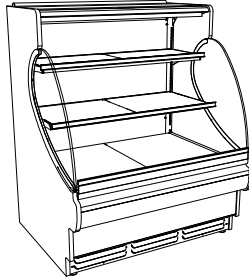

HV48RSS.3635A
Modified Base
Cutaway Ends

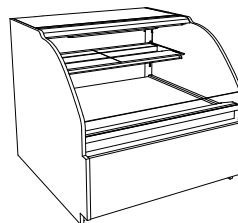

HV(L)48RSS
Straight Base
With Full Ends

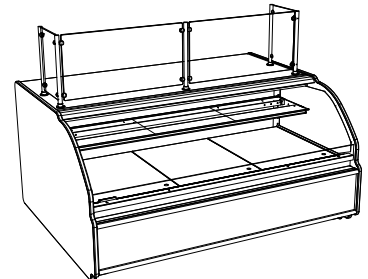

HV3674RSS.5954 With
White Medex® Storage
Unit At Rear

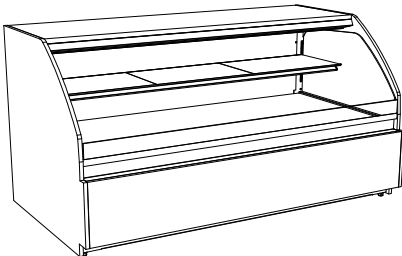

HV(L)39RSS (including Q3713)
Straight Base - Full Ends
HV7439RSS.3713A
Angled Base - Full Ends

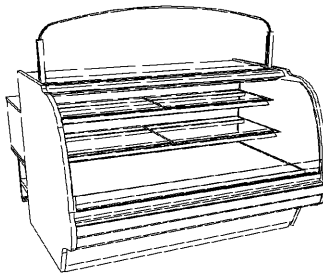

HV42(L)RSS
Angled Base - Full Ends

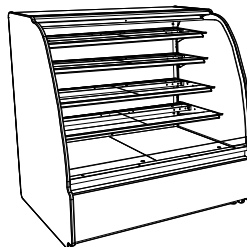

HV(L)56RSS
Straight Base
Full Ends

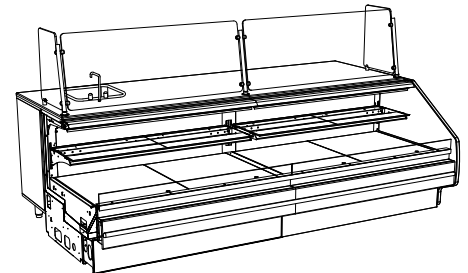

HV36112RSS.4863A
Metal End Panel With Sink

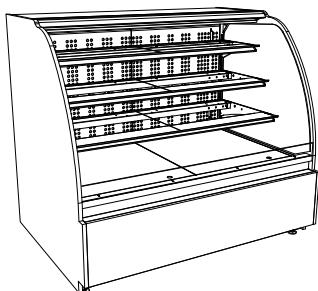

HV(L)RSSRD
Straight Base - Full Ends
Rear Sliding Doors - Plexi Plenum

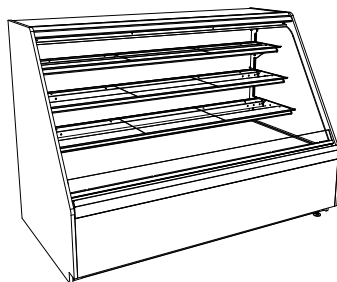

HVK(L)RSS
"K" Series
Straight Base - Full Ends

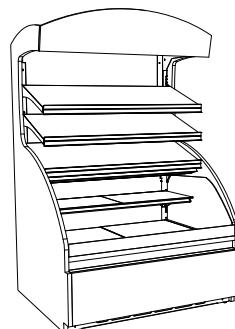

RG2Z5080

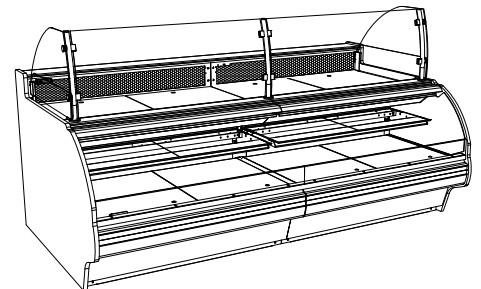

HV36112RSS.4922B
With Patisserie in Top Section
(See Patisserie Section in Manual)

TABLE OF CONTENTS

TABLE OF CONTENTS	2
MODELS LISTED IN MANUAL (AND DETERMINING THEIR RESPECTIVE CASE DIMENSIONS)	3
OVERVIEW / TYPE / COMPLIANCE / WARNINGS / PRECAUTIONS / WIRING	4-5
INSTALLATION: REMOVAL FROM SKID (LEVELERS AND RAILS vs. CASTERS)	6
INSTALLATION: REMOVING LOWER FRONT PANELS (ANGLED vs. VERTICAL / SCREW vs. SLOT)	7
INSTALLATION: ADJUSTING FRONT PANELS / ADJOINING UNITS / GLASS SHELVING	8
INSTALLATION: ELEC. CONNECTIONS / LOCKING CASTERS / ADJUSTING LEVELERS	9
INSTALLATION: REFRIG. LINES / STUB-UPS / DRAINS / WIRING DIAGRAMS / VENTILATION	10
INSTALLATION: DISPLAY CASE START-UP	11
DRAIN, HOSE AND BRACKET PLACEMENT	12
NIGHT AIR CURTAIN OPERATING INSTRUCTIONS (OPTIONAL)	13-14
SECURITY GRID INFORMATION	15-16
MAINTENANCE FUNDAMENTALS - STANDARD LIGHT FIXTURES	17
MAINTENANCE FUNDAMENTALS - LED LIGHTS/BRACKETS/SHELVES/DRAIN/TXV VALVE	18
MAINTENANCE FUNDAMENTALS - REFRIGERATION PACKAGE, TEMPERATURE CONTROLLER, CONDENSATE PAN	19
MAINTENANCE FUNDAMENTALS - HOT GAS LOOP CONDENS. UNITS (HV48RSS.5536, Etc.)	20
MAINTENANCE FUNDAMENTALS - HOT GAS LOOP CONDENS. UNITS (HV3674RSS.5954, Etc.) .	21
MAINTENANCE FUNDAMENTALS - REAR DOORS / REAR PLENUM / MAGNETIC AIR FILTER	22
MAINTENANCE FUNDAMENTALS - MEDEX® STORAGE UNIT/SUPPLY ORGANIZER DRAWERS (MODEL HV3674RSS.5954 ONLY)	23
MAINTENANCE FUNDAMENTALS - PATISSERIE AREA (MODEL HV36112RSS.4922B ONLY).....	24-25
GENERAL CLEANING (TO BE PERFORMED BY STORE PERSONNEL)	26
TROUBLESHOOTING (TO BE PERFORMED BY STORE PERSONNEL)	27
GENERAL CLEANING (TO BE PERFORMED BY TRAINED SERVICE PROVIDERS ONLY)	28
TROUBLESHOOTING (TO BE PERFORMED BY TRAINED SERVICE PROVIDERS ONLY)	29-31
TROUBLESHOOTING (TO BE PERFORMED BY TRAINED SERVICE PROVIDERS ONLY) - CONDENSING SYSTEM	32
TROUBLESHOOTING (TO BE PERFORMED BY TRAINED SERVICE PROVIDERS ONLY) - EVAPORATOR SYSTEM	33
PREVENTIVE MAINTENANCE (TO BE PERFORMED BY TRAINED SERVICE PROVIDER)	34
MAINTENANCE FUNDAMENTALS - HONEYCOMB AIR DIFFUSERS (TO BE PERFORMED BY SERVICE TECHNICIANS ONLY)	35
SERIAL LABEL INFORMATION & LOCATION	36
TEMPERATURE CONTROLLER - CAREL®	37-39
TECHNICAL SERVICE CONTACT INFORMATION & WARRANTY INFORMATION	40

MODELS LISTED IN THIS MANUAL (AND DETERMINING THEIR RESPECTIVE CASE DIMENSIONS)

DETERMINING YOUR MODEL AND ITS CASE DIMENSIONS:

Note 1. Your model number can be found on serial label at rear of case (near main power switch).
Note 2. Dimensions of most models can be found at www.structuralconcepts.com. Simply enter the case model number into the Product Number Search box. Click the **product specification** link for complete dimensions.

Note 3. If your specific model is not found, contact technical service (phone number is listed at Technical Service section in this manual) for dimensions.

Note 4. CDRs (Customer Design Requests) are listed with a 4-digit number. All CDR dimensions are very similar (and some identical) to standard model dimensions.

THIS OPERATING MANUAL ENCOMPASSES THE FOLLOWING MODELS (AND/OR THEIR RESPECTIVE CDRs):

**2287 2595 2613 2613A 2613B 2852C 3153 3916 HVK3696RSS.5159A
HVK36144RSS.5159B HVK48RSS HVK56RSS HVK74RSS
HVK74RSS.5142A HVK96RSS HVK96RSS.5142 HVK4296RSS
HV28RSS HV28RSS.3635B HV38RSS HV38RSSRD HV48RSS
HV48RSS.2917 HV48RSS.3620 HV48RSS.3635A HV48RSS.3735A
HV48RSS.5536 HV56RSS HV56RSS.3928A HV56RSS.3935A
HV56RSS.4203 HV56RSS.5381 HV74RSS HV74RSS.2846B
HV74RSS.2852 HV74RSS.3905B HV74RSS.3941 HV74RSS.3941A
HV74RSS.4104 HV74RSS.4447A HV74RSS.5028 HV74RSS.5543
HV96RSS HV96RSS.3905 HV96RSS.4105 HV96RSS.4645
HV96RSS.5161 HV112RSS HV112RSS.2852D HV114RSS HV144RSS
HV34144RSS HV34144RSS.4993 HV34144RSS.4993A HV3638RSS
HV3648RSS HV3656RSS HV3674RSS HV3674RSS.4922
HV3674RSS.5954 HV3696RSS HV36112RSS HV36112RSS.4922B
HV36112RSS.4992B HV36112RSS.4863A HV4256RSS HV4274RSS
HV4296RSS HV5656RSS HV5656RSS.5382 HV7439RSS
HV38RSSRD HV48RSSRD HV56RSSRD HV74RSSRD HV96RSSRD
HV112RSSRD HVLD48RSS.4125 RG2Z5080
(DOC OPTION #80-02791)**

OVERVIEW

- These Structural Concepts Encore® self-service cases are designed to merchandise packaged products at 41 °F (5 °C) or less product temperatures (unless custom cases with wire rack shelving).
- Cases should be installed and operated according to this operating manual's instructions to insure proper performance. Improper use will void warranty.

TYPE

This unit is designed for the display of products in ambient store conditions where temperatures and humidity are maintained within a specific range.

- For Type 1 Conditions (most cases): ambient conditions are to be at 55% maximum humidity and maximum temperatures of 75 °F (24 °C).
- For Type 2 Conditions: ambient conditions are to be at 60% maximum humidity and maximum temperatures of 80 °F (27 °C).

- If unsure if your unit is Type 1 or Type 2, see tag next to serial label. See **SERIAL LABEL LOCATION & INFORMATION LISTED / TECH INFO & SERVICE** section in this manual for sample serial labels).

COMPLIANCE

- Performance issues when in violation of applicable NEC, federal, state and local electrical and plumbing codes are not covered by warranty.
- See below compliance guideline.

WARNINGS

- Following are important warnings to prevent injury or death.
- Please read carefully!
- See next page for **PRECAUTIONS**.



**ATTENTION
INSTALLER**

COMPLIANCE

This equipment **MUST** be installed in compliance with all applicable NEC, federal, state and local electrical and plumbing codes.

WARNING

**ELECTRICAL
HAZARD**



WARNING

Risk of electric shock. Disconnect power before servicing unit.
CAUTION! More than one source of electrical supply is employed with units that have separate circuits.
Disconnect ALL ELECTRICAL SOURCES before servicing.

WARNING

**KEEP
HANDS
CLEAR**



WARNING

Hazardous moving parts. Do not operate unit with covers removed.
Fan blades may be exposed when deck panel is removed.
Disconnect power before removing deck panel.

WARNING

**HOT
SURFACE**



WARNING

Condenser Pan is Hot!
Disconnect and allow to cool before cleaning or removing from case.

PRECAUTIONS

- Following are important precautions to prevent damage to unit or merchandise.
- Please read carefully!
- See previous page for specifics on **OVERVIEW, NSF TYPE, COMPLIANCE** and **WARNINGS**.

WIRING DIAGRAM

- Each case has its own wiring diagram folded and in its own packet.
- Wiring diagram placement may vary; it may be placed near ballast box, field wiring box, raceway cover, or other related location.

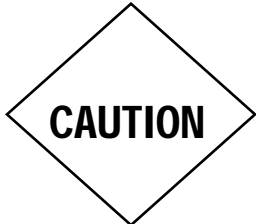

CAUTION! LAMP REPLACEMENT GUIDELINES
 LED lamps reflect specific size, shape and overall design. Any replacements must meet factory specifications.
 Fluorescent lamps have been treated to resist breakage and must be replaced with similarly treated lamps.

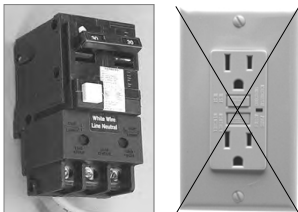

CAUTION! GFCI BREAKER USE REQUIREMENT
 If N.E.C. (National Electric Code) or your local code requires GFCI (Ground Fault Circuit Interrupter) protection, you **MUST** use a GFCI breaker in lieu of a GFCI receptacle.



CAUTION! POWER CORD AND PLUG MAINTENANCE
 Risk of electric shock. If cord or plug becomes damaged, replace only with cord and plug of same type.

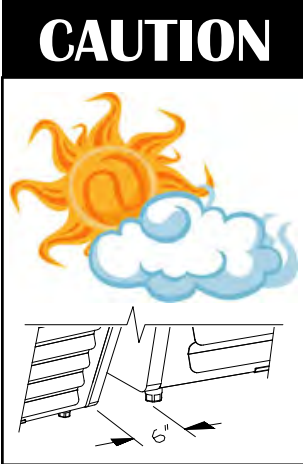

CAUTION! ADVERSE CONDITIONS / SPACING ISSUES

- Performance issues caused by adverse conditions are **NOT** warranted.
- End panels must be tightly joined or kept at least **6-inches** away from any structure to prevent condensation.
- Unit must be kept at least **15-feet** from exterior doors, overhead HVAC vents or any air curtain disruption to maintain proper temperatures.
- Unit must not be exposed to direct sunlight or any heat source (ovens, fryers, etc.).
- Tile floors, low ceilings or small rooms increase noise level. Whisper Cool compressor blankets or remote units resolve noise level issues.
- Keep at least **8-inch** clearance above unit for air discharge (self-contained units only).

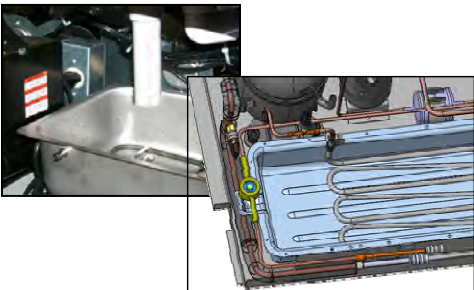

CAUTION! CHECK CONDENSATE PAN POSITION AND PLUG
 Water on flooring can cause extensive damage!
 Before powering up unit, check the following:

- Condensate pan **MUST BE** positioned directly under condensate drain.
- Condensate pan plug **MUST BE** securely plugged into receptacle.

INSTALLATION: REMOVAL FROM SKID (LEVELERS AND RAILS vs. CASTERS)

1. Remove Case From Skid (Levelers and Rails)

- Remove shipping brace that may be securing case to skid.
- Support case to prevent tipping.
- *Caution! Levelers can be damaged if case hits floor with heavy force!*
- Carefully slide unit to rear of skid and tip backward off skid.
- Illustration may not reflect every feature or option of your particular case.

Note: Case can be repositioned with pallet truck when front lower panel is removed. Blocking may be necessary to obtain adequate height.

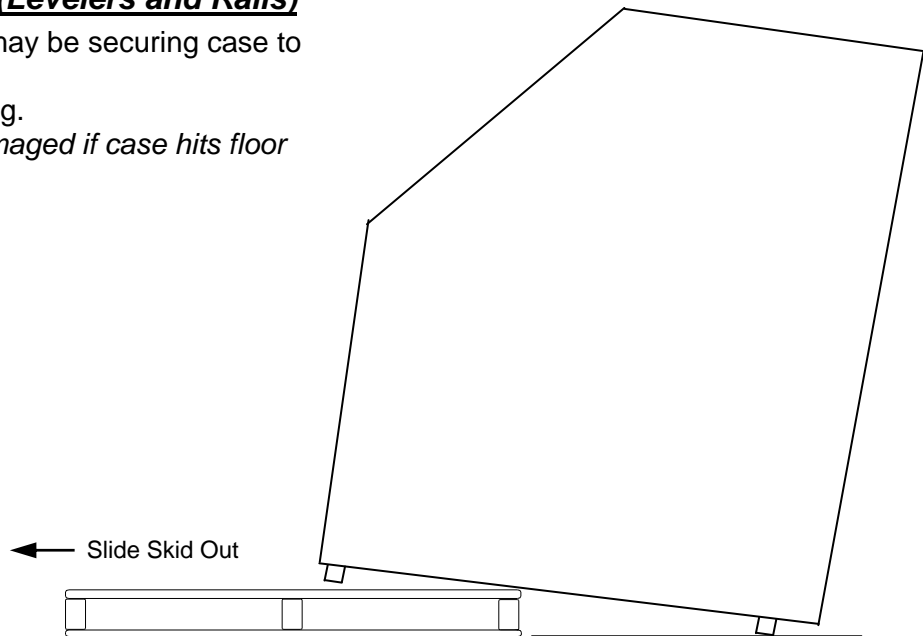

Note: Illustrations shown reflect a general outline of sample cases and do not reflect features or options of your particular model.

2. Remove Case From Skid (Casters)

Remove shipping brackets that may be securing casters to skid

- Place ramp up against skid (to allow case to smoothly slide off from skid).
- Maintain support of case at all times or center of gravity may cause case to fall.
- Unlock Casters. Roll unit to rear of skid. Roll down ramp and off from skid.

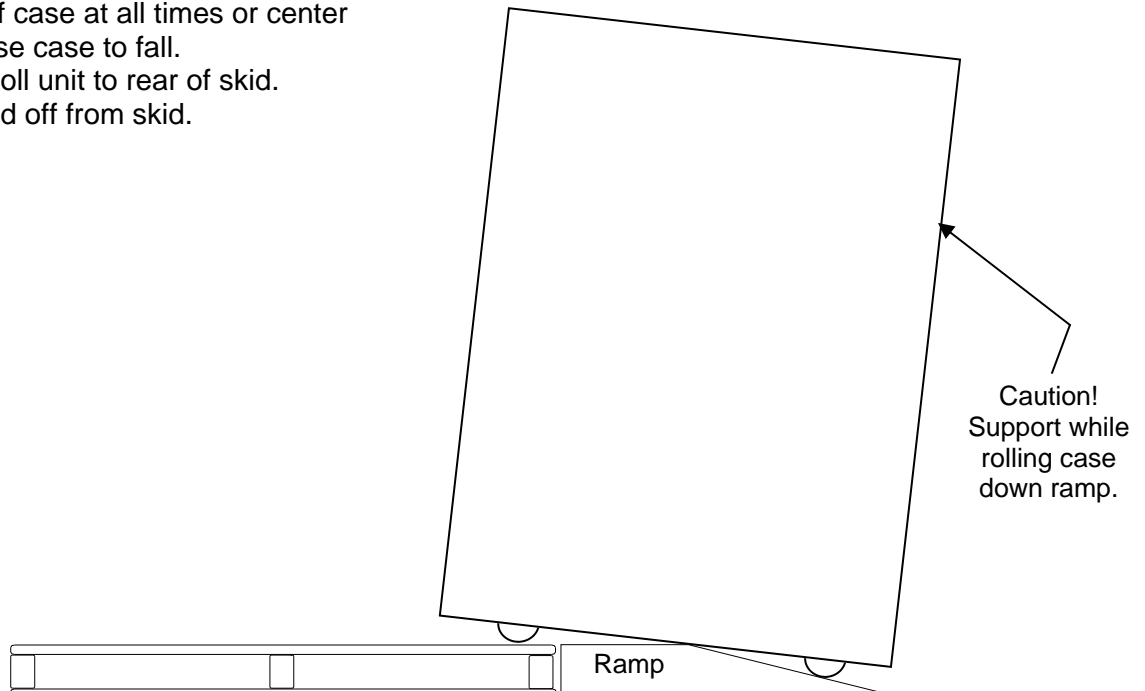

INSTALLATION: REMOVING LOWER FRONT PANELS (ANGLED vs. VERTICAL / SCREW vs. SLOT)

3A. Angled Lower Front Panels (Screws)

Upper Panel Support:

>> Remove screws located behind upper front panel. Lower

Panel Support:

>> For most applications, screws secure the lower panel support (located below front panel) to the unit.

>> See illustration at top-right.

3B. Vertical Lower Front Panels (Screws)

> Front Panel Upper Support (With Screws): Remove caps & screws holding deck support in place.

> Front Panel Lower Support (With Screws): For most cases, screws secure the front panel lower support to base.

>> Remove screws holding front panel lower support to display case base.

>> Vertical lower front panel can now be removed.

>> See illustration at mid-right).

3C. Front Panel Removal / Replacement

>> No screw removal is required for removing front panel.

>> Raise front panel up (lifting slots off hooks) inside front panel support bracket and pivot outward to free slots from front panel hooks. Lower front panel downward and out, away from case.

>> Place panel in secure location while performing cleaning or service.

>> Return front panel in reverse order it was removed.

3D. Lower Toe-Kick Removal / Replacement

>> No screw removal is required to removed lower toe-kick.

>> Simply lift lower front panel slots up and off case hooks.

>> Place panel in secure location while performing cleaning or service. Replace in reverse order it was removed.

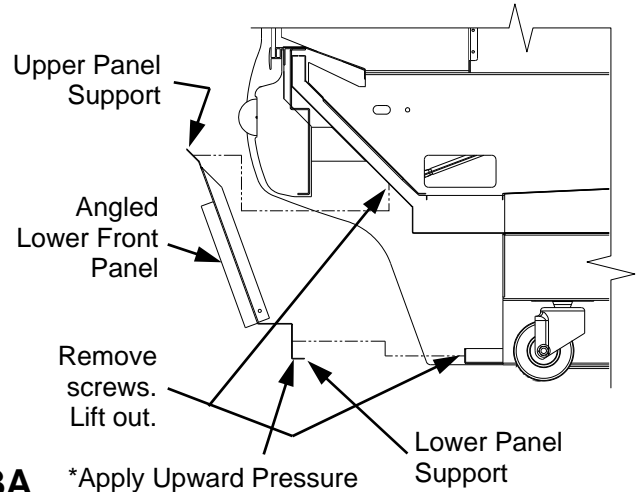

3A *Apply Upward Pressure

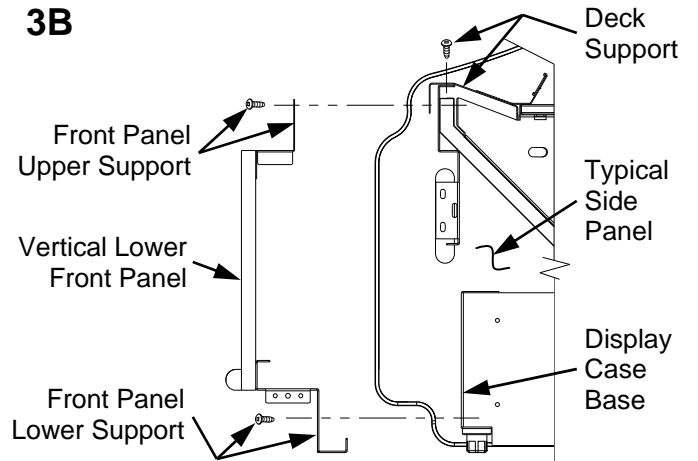

3B

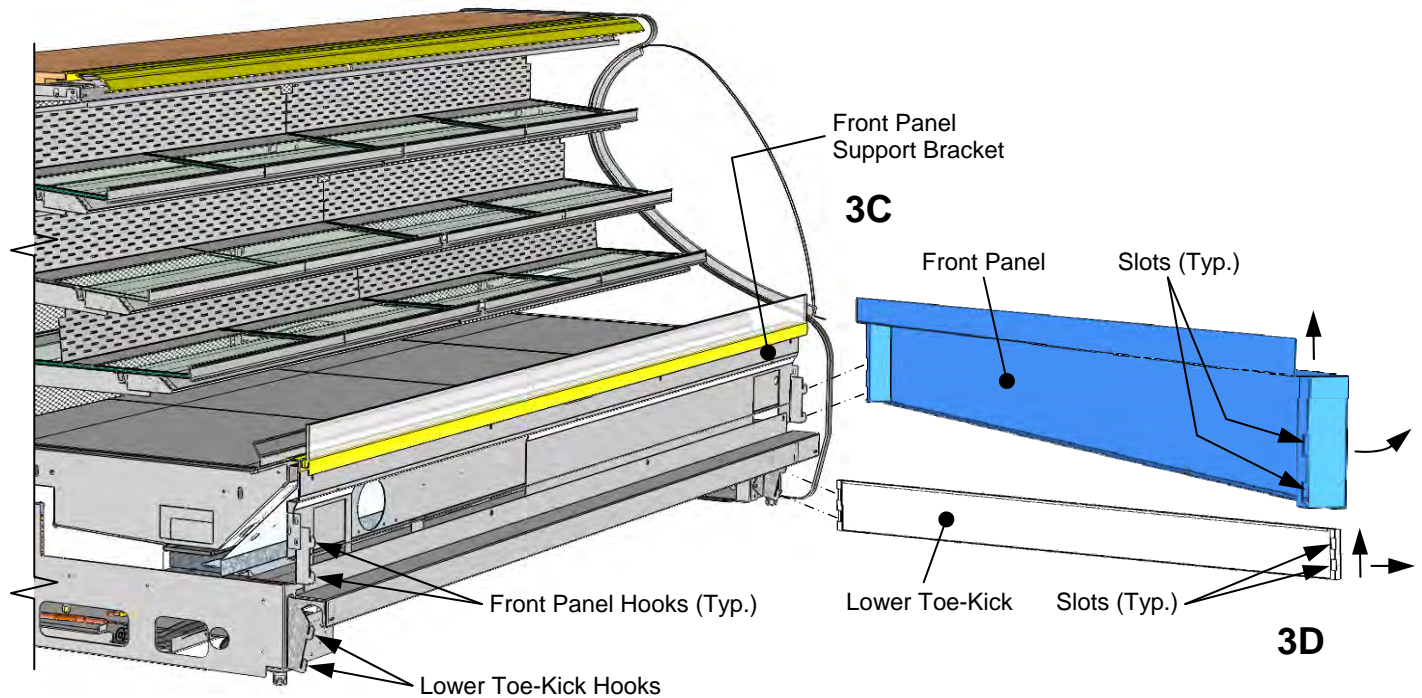

3C

3D

INSTALLATION: ADJUSTING FRONT PANELS / ADJOINING UNITS / GLASS SHELVING

4. Adjusting Upper Front Panels

- Remove screw cover and loosen adjustment screws.
- Adjust alignment and tighten screws.
- See illustration at mid-right.

5. Bolting and Caulking Units Together

Follow these steps to assure a secure, level lineup.

- Begin lineup leveling from highest point of floor.
- After the 'first' case is level, apply industrial grade butyl caulk on non-visible areas (at case end). Use industrial grade silicone sealant on visible areas (at case end).
- Form Two (2) Caulk/Sealant Lines: (Sanitation and Refrigeration). See illustration at mid-right for outline of caulk/sealant lines.
- Line up 'second' case bolt-hole to bolt-hole to 'first' case.
- Using SCC-supplied bolts (found in installation packet), insert bolts in bolt hole locations (shown at right). You may need to remove decking to access lower bolt holes.
- Caution! Front of cases MUST be flush with each other! After leveling, cases are to be same height.
- Using SCC-supplied nuts & bolts, **lightly tighten** each of the 5 to 8 bolts in a cross-wise pattern. Work your way around the pattern, tightening more firmly at each pass. **Do not** firmly tighten one bolt and then start on the next!
- After the cases are bolted together, level the 'second' case. Repeat this process for each case to be adjoined.
- After all lined-up cases are level, seal all seams with industrial grade silicone sealant.

6. Glass Shelving (or Sneeze Guard)

Glass shelving and (on certain cases sneeze guards) will be packed separately.

- Caution! Two installers may be required to properly lift and install of large pieces.
- Grasp firmly and carefully install.
- *Caution! Check that plastic edging is intact before placing glass shelving onto brackets!*
- Plastic edging must not be removed from glass shelves. Contact Structural Concepts for replacement edging (see **TECHNICAL SERVICE CONTACT INFORMATION** section).
- Check that glass shelving is in proper position before placing product in case.

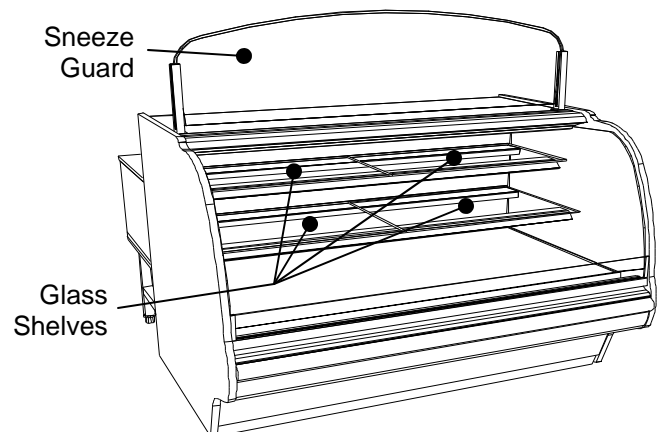
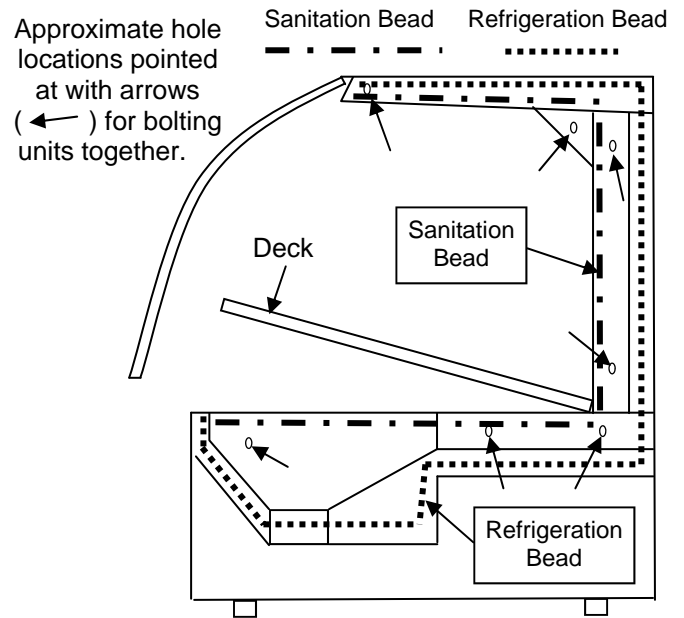
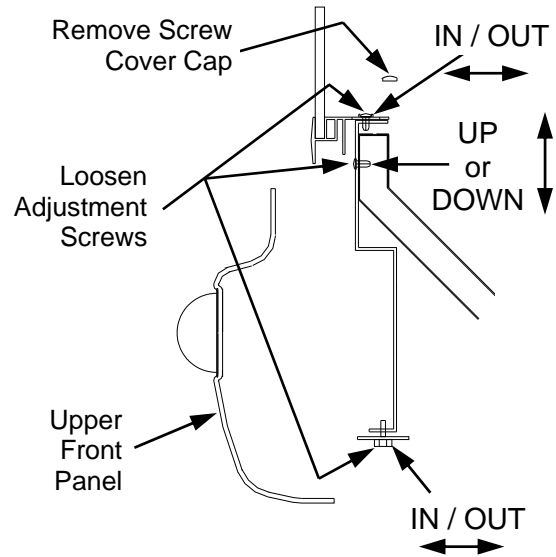

7. Electrical Connections

A. Rear Wire-Ways

- Remove screws from rear wire-way cover to access electrical leads.
- Wiring runs case to case through base cut-outs.
- Knockout is provided in bottom of wire-way for stub-up connection.
- See illustration at top-right.

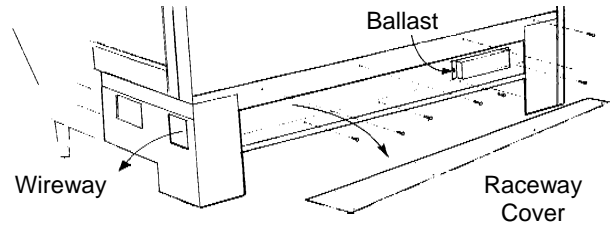

Note: Wiring process must be performed by certified electricians only.

- Voltage rating is on serial label at case rear.

B. Rear Ballast Box

- Remove 4 screws from ballast box face.
- Remove screws from rear panel (if any).
- Remove 3 screws from inner support.
- Knockouts are located on side and rear of box for making electrical connections.

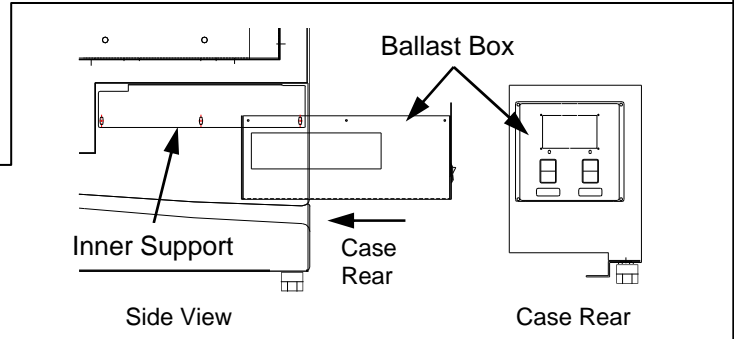

Note: Wiring process must be performed by certified electricians only.

- Serial label (at case rear) lists voltage rating.

C. Front Ballast Box

- Remove front panel.
- Stub-up connections are in ballast box.
- Remove ballast box covers.
- Knockouts are on sides and front of ballast assembly for making electrical connections.

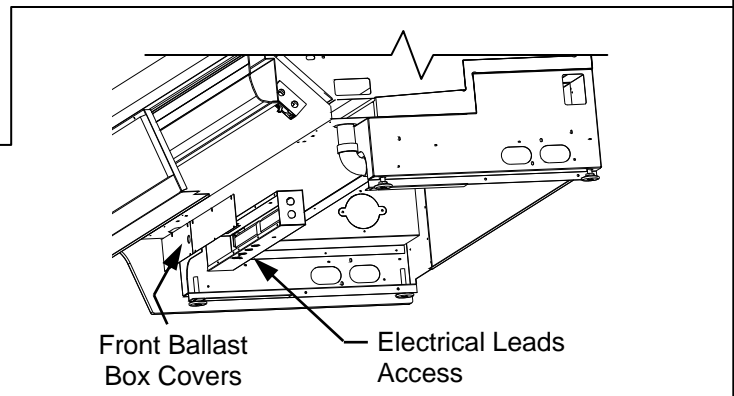

Note: Wiring process must be performed by certified electrician only.

- Voltage rating is on serial label at case rear.

8. Cases With Casters: Lock and Unlock

- To lock casters, press down on lever.
- To unlock casters, pull lever up.
- See illustration at right.

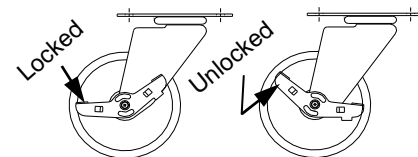

9. Cases With Levelers: Adjust Levelers

- After case is in position, adjust case so it is level and plumb (see illustration at right).
- You may need to remove front and/or rear Toe-Kick to access levelers.
- Use adjustable wrench (and possibly a pry bar) to adjust leveler.
- Do not use pry bar on toe-kick (it may buckle).
- Do not use pry bar on end panel (it may chip).
- Use pry bar ONLY on base frame to avoid damaging case.
- Use a block to reach base frames with pry bar.
- See illustrations at right.

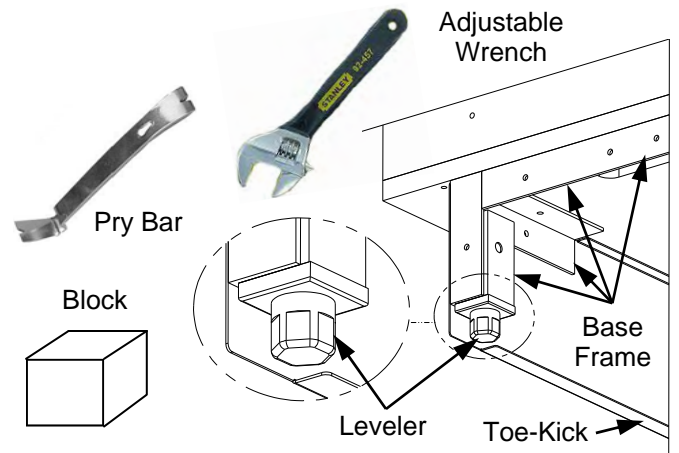

10. Refrigeration Line Stub-Up Connections (Remote Units)

- Remove front panel.
- Refrigerant stub-up access opening is at the front on the left hand side of the base (see illustration at top-right).
- Stub-up connections are accessed from inside the case.
 - Remove interior ABS decks.
 - Remove fan shroud assembly.
- Line connections are in the tub front, on the left hand side
- Remove foam material from the entry hole provided in the tub drain trough.
- Route refrigerant lines through access hole.
 - Run case-to-case connections through cutouts in base.
 - Sweat the high and low pressure connections.
- Fill access hole with suitable filler to insure watertight integrity of tub.
- Illustration at top-right may not reflect every feature or option of your particular case.

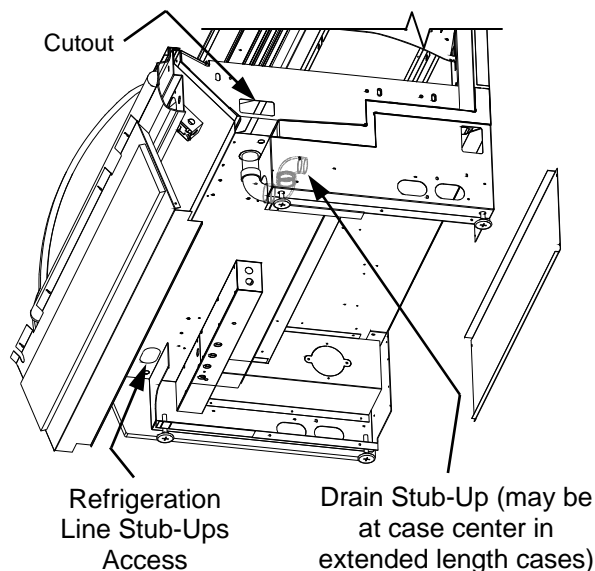

11. Refrigeration Drain Connection (Remote Units)

- Depending upon drain access needs, either front or rear panel may be removed to gain access to drain stub-up.
- 1.5" male PVC stub-up connection is under the case on the right hand side.
- Drain stub-up may be at case center in extended length cases.
- Connect tub drain to floor drain. Maintain 1/4"-fall per foot to provide proper drainage.
- Illustration at top-right may not reflect every feature or option of your particular case.

12. Condensate Pan / Drain Position (Self-Contained Units)

- Remove the rear Panel by lifting up & out.
- Slide the refrigeration package out from case.
- Condensate pan is now accessible.
- Insure that the condensate pan is positioned under the PVC condensate drain trap.
- **Caution! Check that condensate pan is plugged into receptacle inside base. If not, water may drain onto floor, causing damage!**
- Lower rear panel back into place.

- See **Drain, Hose and Bracket Placement** section in this operating manual for details.

13. Electrical Wiring Diagram

- Each case has its own wiring diagram folded and in its own packet.
- Wiring diagram placement may vary; it may be placed near condenser fan cover, ballast box, raceway cover, or other related location.

14. Ventilation and Clearance

- **Self-Contained** refrigerated cases must maintain airflow clearance of 6" (minimum) to 12" (recommended) at front and rear.
- Restriction of air can void warranty.
- Illustration below may not reflect every feature or option of your particular case.

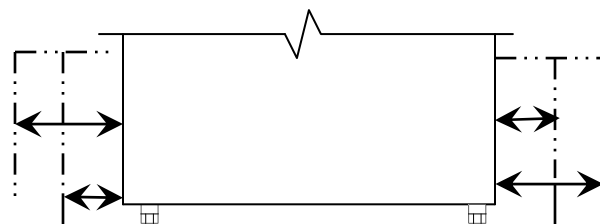

Check air grilles for obstructions. Maintain airflow clearance of 6" (min.) to 12" (recommended) at front & rear.

INSTALLATION: DISPLAY CASE START-UP

15. Display Case Start-Up

A. Case

- Turn main power on at case rear.
- From the front of the case, lift deck to check that the coil fans are functioning properly.
- Coil fans, (and in self-contained units, the compressor motor) should turn on.

B. Lights

- Turn lights on.
 - > Self-Contained Units: Switch at rear.
 - > Remote Cases: NO SWITCH (lights come on when main power switch is turned on).
- All lights should come on at the same time. First time lighting may require a short warm-up period for the bulbs.
- Slightly dim / flickering of new bulbs is normal. If lights do not turn on, check raceway plugs.
- Lighting is wired in series so **all lights must be plugged in or receptacles capped** for case lights to be on. See illustration at right.
- LED Lights: If lights do not come on, check that plug is properly inserted into socket.

C. Temperature Controller (All Self-Contained Units and some Remote Units)

- Check that compressor symbol light is on.
- Depending upon SCC-Supplied temperature controller, compressor is identified with either:

 Compressor symbol (common in Carel® temperature controllers).

 Snowflake symbol (common in CPC® temperature controllers).

- After case has run for a few minutes, check that temperature starts to drop.
- If temperature controller does not begin cooling (in a few minutes) see temperature controller section in this operating manual for instructions.
- Remote units (without temperature controller on case): Verify that refrigeration requirements listed on serial label (found on the case) are being met.

D. Saturated Suction Temperature (Remote Units)

- See serial label on case for suction temperature requirements and BTU requirements.
- See serial label on case for defrost schedule and temperature termination parameters.

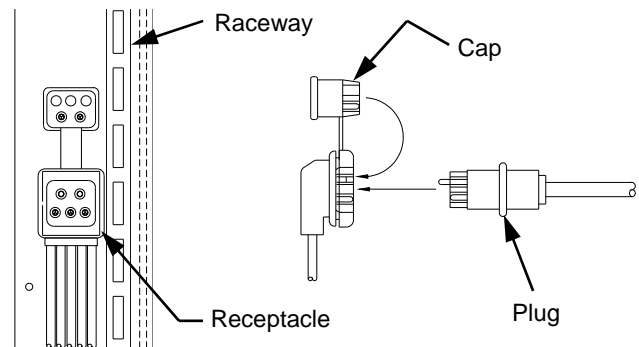
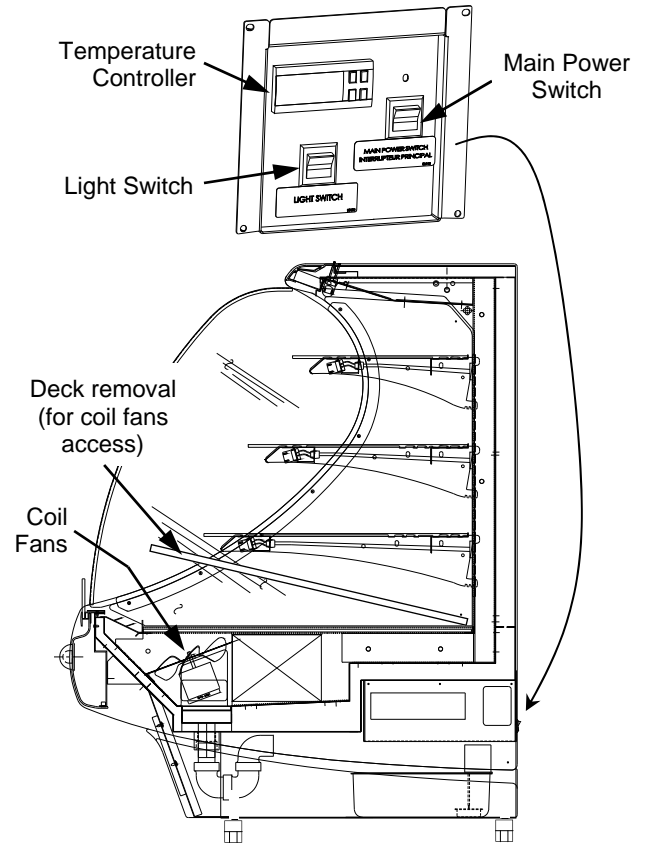

Raceway Receptacle, Plug and Cap



Sample Carel® Controller Face



Sample CPC® Controller Face

NOTE: BELOW ILLUSTRATIONS MAY NOT EXACTLY REFLECT EVERY PARTICULAR CASE'S FEATURES

DRAIN, HOSE AND BRACKET PLACEMENT ILLUSTRATIONS

Three Condensate Systems Are Illustrated Below:

Illustration #1: Hot gas "CopeVap" condensate system. "Copevap" is built into compressor unit.

Illustration #2: Hot gas condensate system.

Illustration 3A/3B: Electrical heat rod condensate system. **Note:** Separate condensate pan.

>> **Warning!** Regardless of condensate system, hose and drain trap **MUST BE** secured and positioned over condensate pan to prevent water seepage / spillage.

>> When sliding out condenser unit, be careful that drain is not pulled from proper position.

2. Hot Gas Condensate System

- Hot gas serpentine coil is routed through a condensate reservoir allowing water to be heated. This system uses a wicking material (partially submersed) with warm condenser air passing through it for evaporation.
- Also incorporates an overflow reservoir with heating element to ensure complete condensation removal.

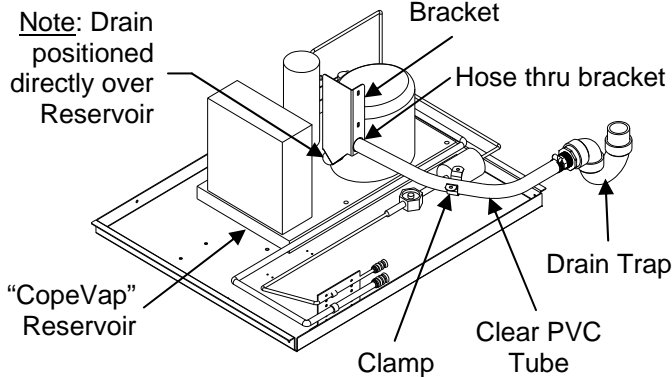
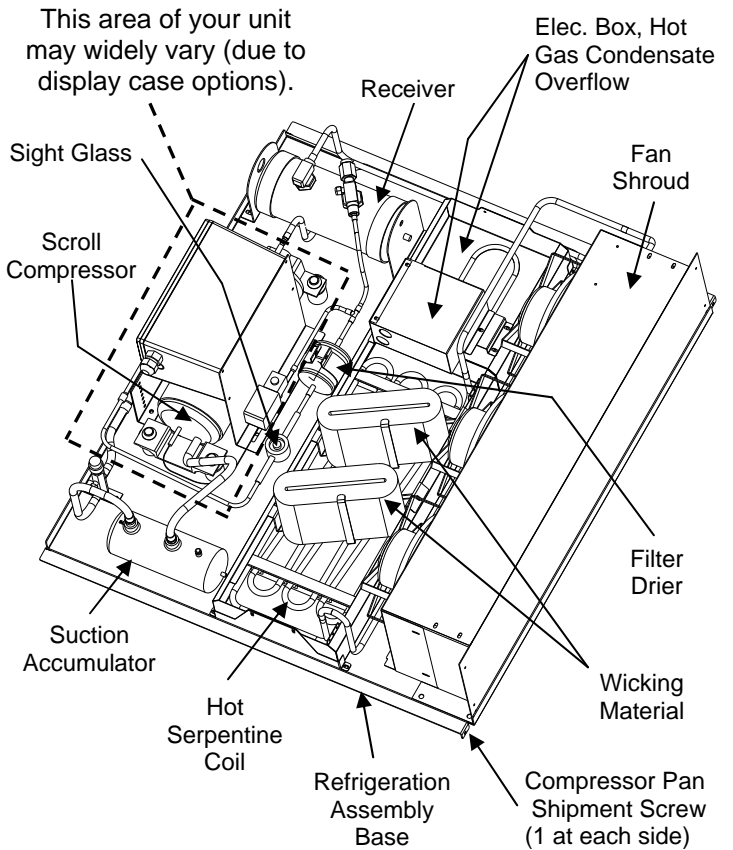

1. Hot Gas "CopeVap" Condensate System

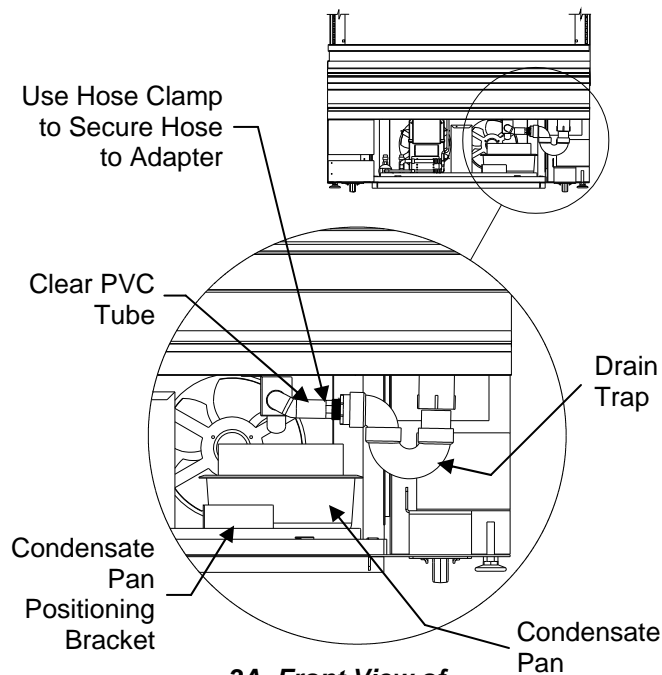

3A. Front View of Electrical Heat Rod Condensate System

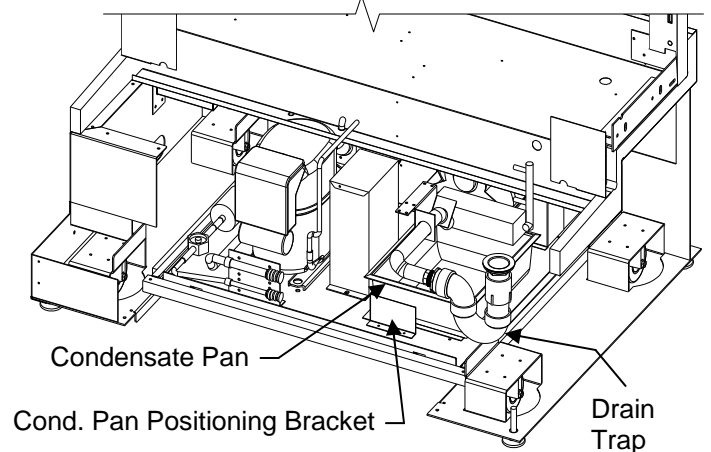

3B. Isometric View of Electrical Heat Rod Condensate System

Night Air Curtain Installation & Operating Instructions

1. Use caution when handling Night Air Curtain.
2. Display case may come with Night Curtain already attached. If not, a retrofit kit will be provided. If using SCC-supplied retrofit kit, attach to display case by centering night curtain along top-front of case as shown in illustration below. Attachment Magnets will hold Night Air Curtain firmly in place. To attach to display case, place night curtain on top of case as shown. Mark "key slot" locations using night curtain as a template (you may have to retract the curtain from housing to reveal "keyslots"). Drill $\varnothing 1/32$ " holes in top board 1/2" deep. Press "finserts" (shown below) into holes. Carefully tap in with flat object to prevent top board damage. Attach Night Air Curtain with #10-32 screws.
3. Grasp the handle and pull downward to desired location INSIDE acrylic sneeze guard.
4. To return Night Air Curtain to its retracted position, grasp handle, lift up and away from its magnetic attachment and carefully wind Night Air Curtain back into roll.
5. Caution! Do not allow spring-loaded Night Air Curtain to freely snap back into roll. Doing so can eventually destroy Night Air Curtain's tension and retractability.
6. To entirely detach Night Air Curtain from case, retract curtain (to access keyslots), remove screws. Lift Night Air Curtain upward and away from case.

NOTE: THE BELOW ILLUSTRATION MAY NOT EXACTLY REFLECT EVERY PARTICULAR CASE'S FEATURES OR OPTIONS.

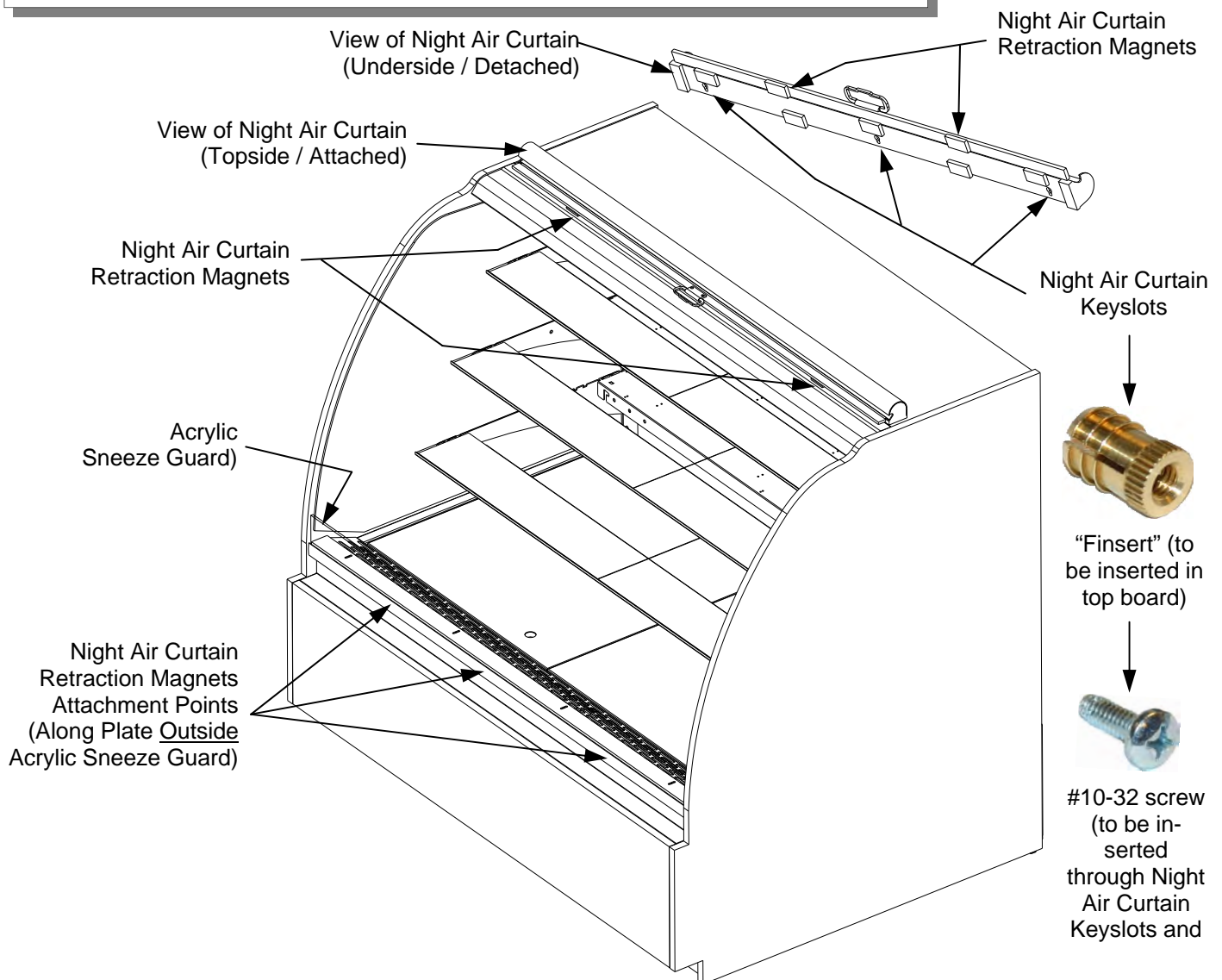

Night Air Curtain Installation & Operating Instructions

1. Use caution when handling Night Air Curtain.
2. Display case may come with Night Air Curtain already attached. If not, a retrofit kit will be provided. If using SCC-supplied retrofit kit, place night curtain on top of case as shown. Mark "keyslot" locations using night curtain as a template (you may have to retract the curtain from housing to reveal "keyslots". Drill $\text{Ø}11/32$ " holes in top board $1/2$ " deep. Press the "finserts" (shown below) into holes. Carefully tap in with flat object to prevent top board damage. Attach Night Air Curtain with #10-32 screws.
3. Grasp the handle and pull downward to desired location OUTSIDE acrylic sneeze guard (see illustration below).
4. To return Night Air Curtain to its retracted position, grasp handle, lift up and away from its magnetic attachment and carefully wind Night Air Curtain back into roll.
5. **Caution!** Do not allow spring-loaded Night Air Curtain to freely snap back into roll. Doing so can eventually destroy Night Air Curtain's tension and retractability.
6. To entirely detach Night Air Curtain from case, retract curtain (to access keyslots), remove screws. Lift Night Air Curtain upward and away from case.

NOTE: THE BELOW ILLUSTRATION MAY NOT EXACTLY REFLECT EVERY PARTICULAR CASE'S FEATURES OR OPTIONS.

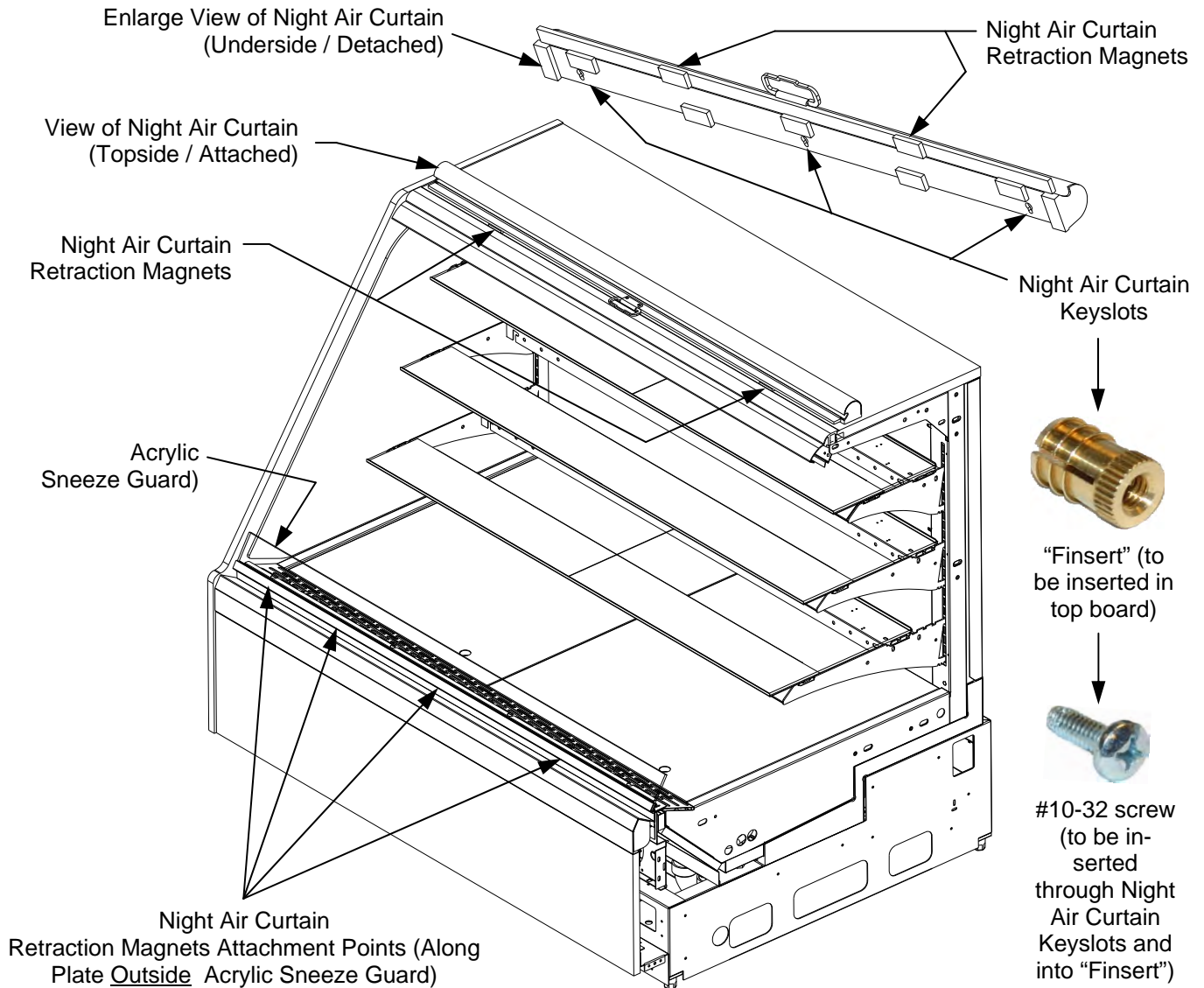

Initial Positioning and Installation of Security Grid

1. Due to weight and size, Security Grid installment requires two (2) people.
2. After hoisting the Security Grid directly over Front Air Deflector, drop the (2) Security Grid Positioning Tabs into the Baffle Airflow Slots (see enlarged view below).
3. After securely positioned in the Baffle Airflow Slots, carefully and slowly lean the Security Grid back against the two Security Brackets.
4. The next page in this manual will show how to secure the top of the Security Grid to the Security Brackets.

**NOTE:
ILLUSTRATIONS
MAY NOT
REFLECT EVERY
CASE'S SPECIFIC
FEATURES**

Enlarged View (Below)

- Enlarged View (shown below) shows Security Grid Positioning Tab slid into Baffle Airflow Slot.
- There is one Security Grid Positioning Tab on each Security Grid end.
- Tabs must be securely positioned in both Airflow Slots prior to locking with Padlocks.

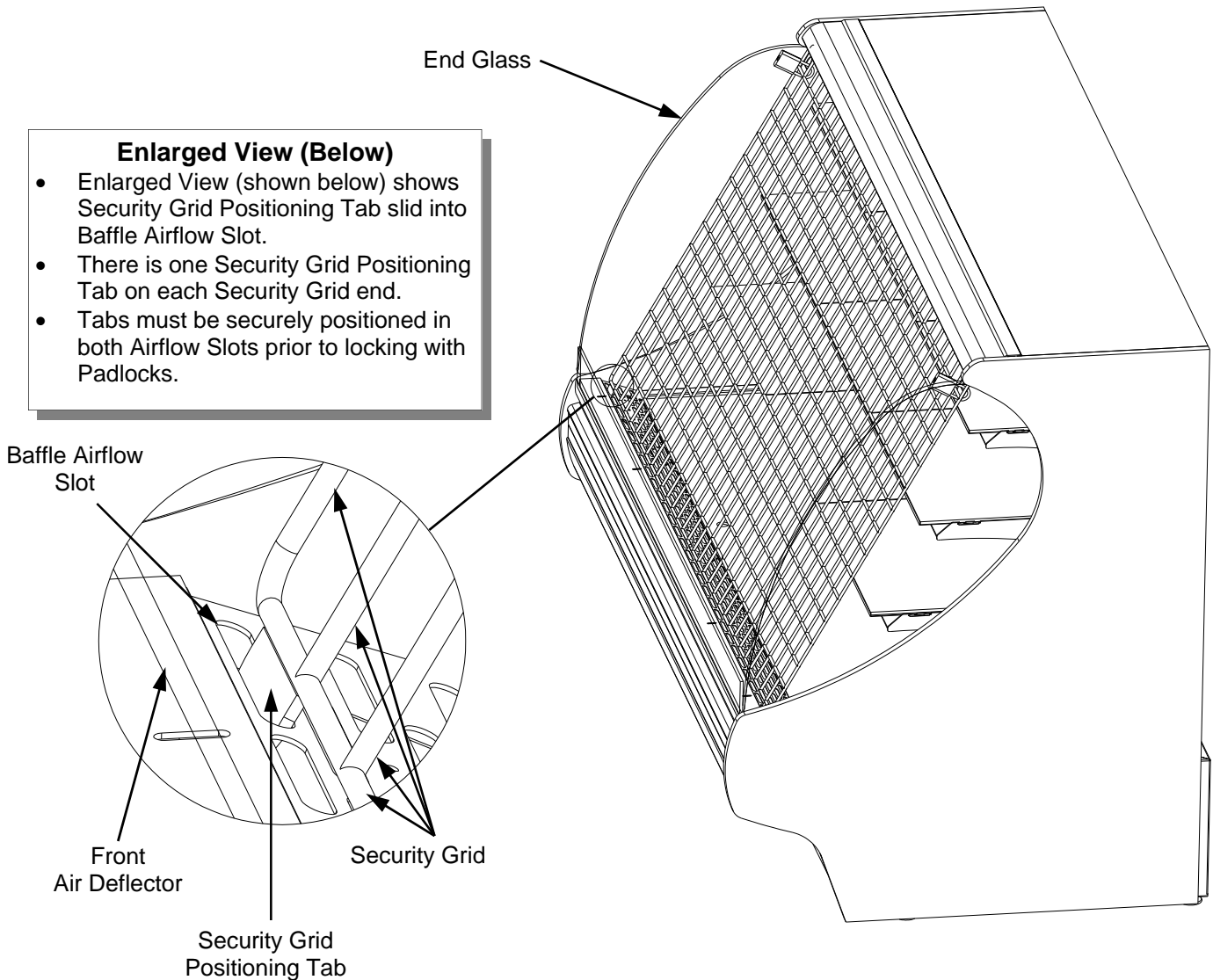

Securing Security Grid Into Place and Locking

1. After leaning the Security Grid back against the two Security Brackets, slide the (two) Padlocks through the Security Grid and the Security Brackets.
2. Securely lock the Padlocks (one Key fits both Padlocks).

Removing and Storing Security Grid and Locks

1. Due to weight and size, Security Grid removal requires two (2) people.
2. Unlock and remove Padlocks. Lean Security Grid forward. Lift upward and out of Baffle Airflow Slots.
3. Store Security Grid, Padlocks and Keys in a secure location to prevent theft or damage.

**NOTE:
ILLUSTRATIONS
MAY NOT
REFLECT
EVERY CASE'S
SPECIFIC
FEATURES**

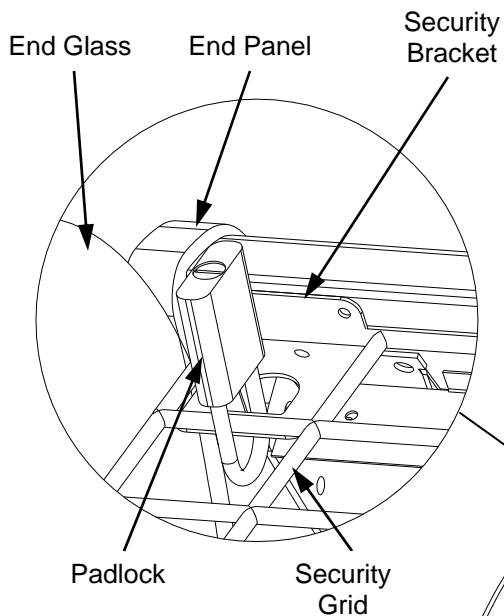

Enlarged View (At Left)

- Illustrates padlock through both security grid and security bracket.
- Note: One security bracket at each end of display case.

Note: Both Casters and Levelers shown for illustrative purposes only.

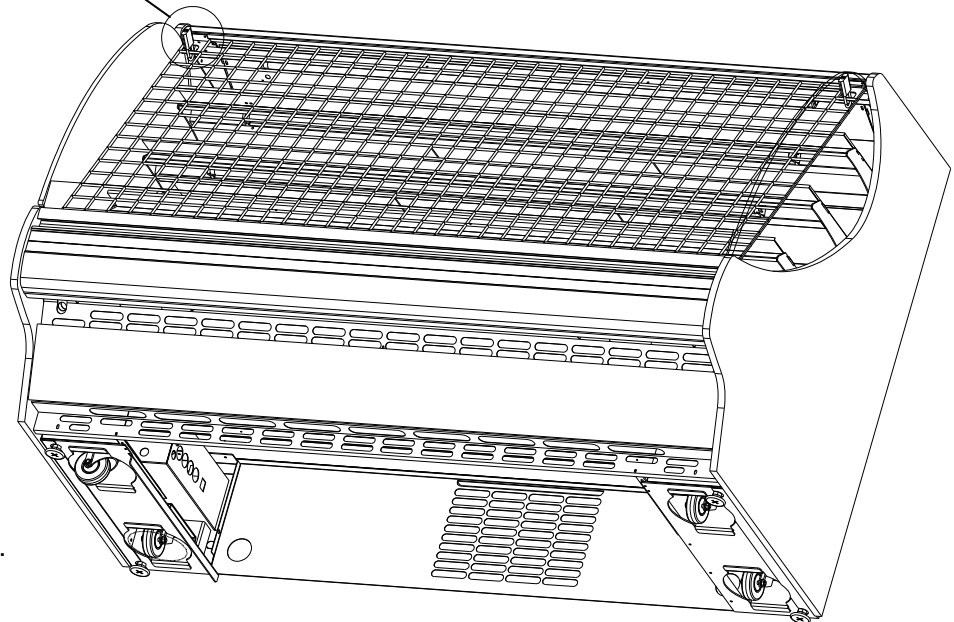

Note: See Installation section in this manual for:

- **Front Panel adjustment and removal**
- **Angled Base adjustment and removal**
- **Vertical Base adjustment and removal**

Light Fixtures

Warning! Disconnect power before providing maintenance and service to unit.

Caution: Lamps have been treated to resist breakage and must be replaced with similarly treated lamps.

Note: Warranty will be void if claims arise from negligence, misuse of goods, extreme environmental conditions or improper maintenance. See Overview And Warnings section in this operating manual.

Light fixtures are located on underside of shelf assemblies and at the top inside of case (just beyond Honeycomb Air Diffuser). See illustration at top-right for locations.

Removal of lamp:

- Rotate lamp (1/4-turn) either direction to disengage (upper or lower) pins/contacts from lamp-mounting sockets.
- Remove bulb by applying even pressure from back side at the bulb ends and pulling the remaining contact from sockets.
- See illustrations at mid and lower-right.

Installation of lamp:

- Align pins with slot.
- Insert pins into socket by rotating the bulb 1/4-turn to secure either the (upper or lower) pin contacts into the sockets.
- Rotate remaining bulb contacts (1/4-turn) into remaining lamp mounting socket contacts.
- See illustrations at right.

See next page for LED Light Fixture information

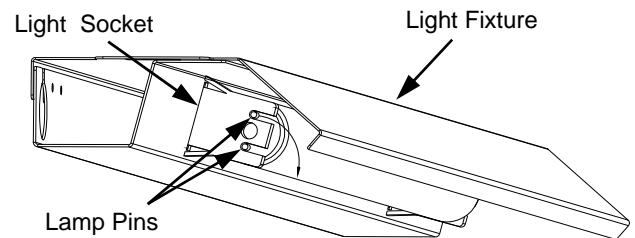
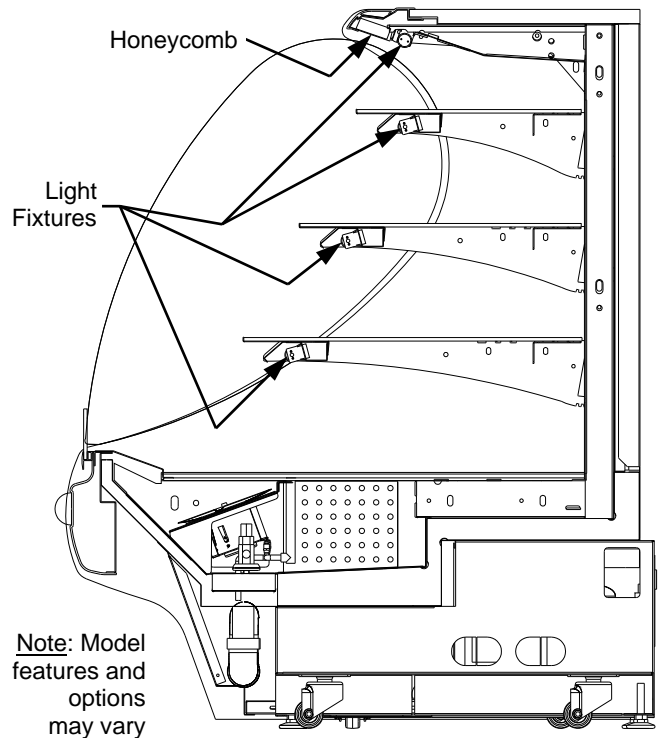

1. LED Light Removal / Replacement:

- LED lights they rarely require change-out.
- Contact Structural Concepts' Technical Service Department for replacement parts (see Technical Service section of this guide).
- To remove LED light fixture, disconnect existing LED light from its brackets & self-adhesive tape.
- Then, firmly grasp LED light while applying outward pressure to brackets.
- Twist the LED away from the bracket to release.

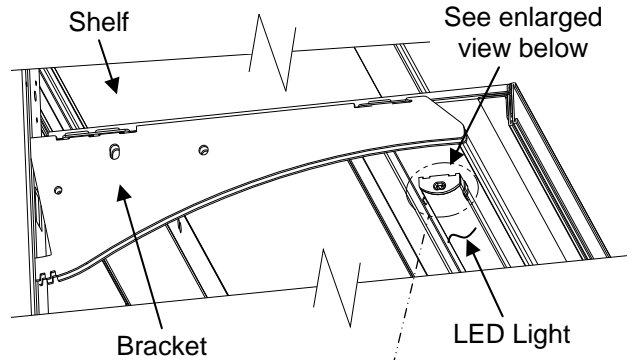

2. Plug and Cord Positioning:

- Plug is to connect to LED light at raceway side of case.
- Before attaching LED light to case, plug must connect to LED properly without cord doubling-back.
- See photos of proper vs. improper connections.

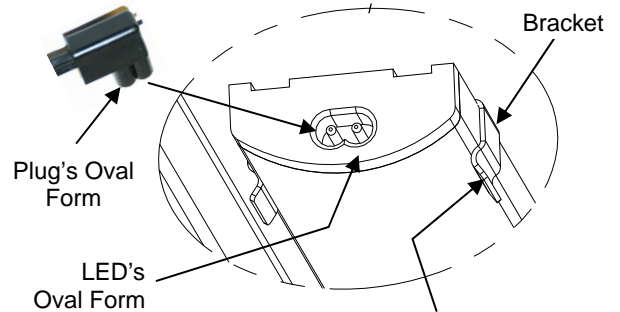

Outward pressure to be applied to bracket to remove LED light

3. Proper Plug Insertion Into LED Light:

- Plug must be inserted into LED light properly or the LED will not light up.
- Oval form of plug is to connect to LED light oval form.
- See illustration at right.

See previous page for Standard Light Fixture information.

4. Bracket Retainer Removal

- To remove brackets, it may be necessary to remove the nylon shipping bracket retainers.
- Pliers will be required to accomplish this task.
- See illustration at top-right for location of bracket retainers.

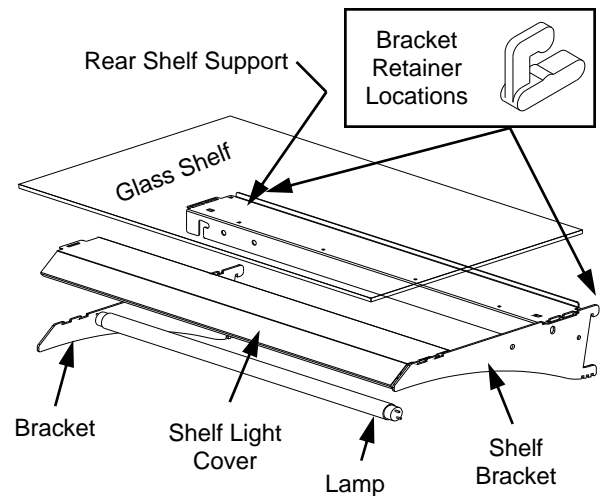

5. Shelf Assembly Removal

- Remove glass shelves
- For lighted shelving, unplug the light cord.
- Remove rear shelf support.
- Remove shelf light cover from brackets.
- Lift brackets up and out.

6. Drain and Expansion Valve Access

- The drain and expansion valve are both accessible from the front of the case.
- Unplug the fans (one plug per side) and remove the fastener from the access panel in the front right (or left) corner of the unit.
- The drain and the expansion valve (TXV) are directly below the access panel.

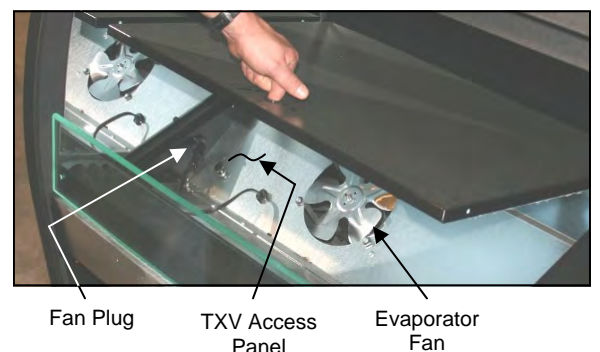

Refrigeration Package Access

Note: Servicing to be accomplished by licensed electrical / refrigeration contractor.

1. Air Filter

- Magnetic strips attached to the filter adhere the filter to the rear grille.
- Clean the nylon mesh filter by rinsing thoroughly with water against the air flow direction.
- Mild detergent removes smoke & grease stains.
- See illustration at top-right.

2. Pull Out Refrigeration Package

- Remove the rear grille. Grille may be slid upward and out.
- **Note:** At initial slide-out, it may be necessary to remove Compressor Pan Shipment Screws (see illustration at right for location).
- *Refrigerant lines are flexible to facilitate rear access maintenance.*
- Plastic glides are mounted at base to assist in sliding the condenser out for access.
- Service connections are at the left of compressor.
- Slide condenser unit out 12 to 18 inches to access high pressure service connection.

3. Temperature Controller (Self-Contained)

- Temperature Controller is located in the Ballast Box.
- Temperature / Defrost control settings are programmable from these locations.
- Case Temperature Set Point is set at the factory, as determined by case size & sensor probe location.
- Temperature is controlled by thermostat.
- If a temperature setting change is required, follow instructions regarding Temperature Control Programming Steps in the technical information section of this operating manual.
- If service is required to the temperature control unit, call Structural Concepts Corporation. Maintenance should be performed by a certified technician.
- The toll-free number is listed in the Technical Service section of this manual.
- See Temperature Controller section in this manual.

4. Thermometer

- Thermometers provided with equipment reflect internal air temperature only (not actual food temperature).
- Use probe thermometers to determine actual product temperatures.

The illustration below may not depict an exact representation of your particular unit.

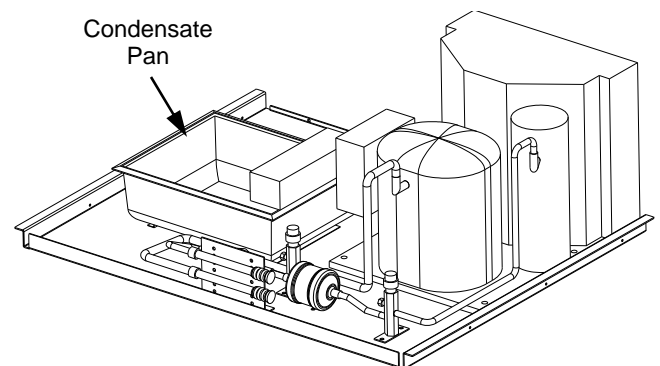
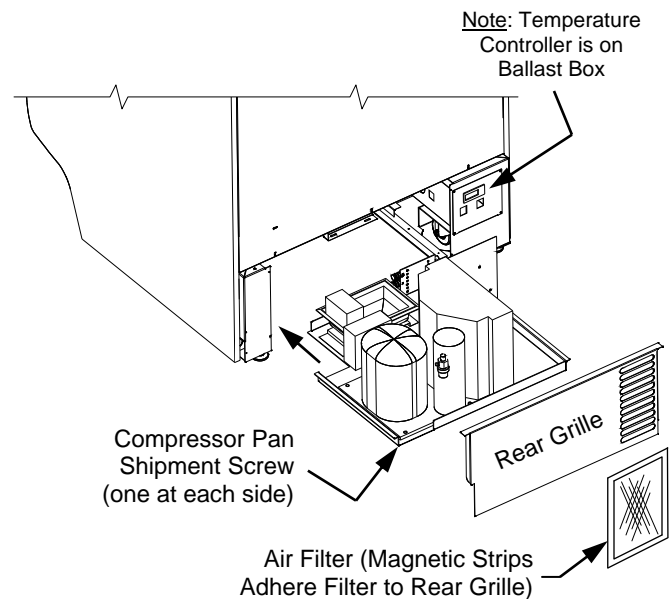

Note: Illustration shown may not exactly reflect your case's refrigeration package layout.

5. Condensate Pan Access / Removal

- Turn off main power; allow condensate pan to cool.
- Lift rear grille up and off (no tools required).
- **WARNING! Condensate Pan May Be Hot!** Check temperature of pan prior to handling.
- Withdraw condensate pan from the right side behind electrical box.
- Unplug condensate pan from the electric outlet.
- Empty condensate pan contents into suitable container. Replace rear panel when completed.

>> See next page for layout of Hot Gas Loop condensate system.

Hot Gas Loop Condensate Units (Model HV48RSS.5536, etc.)

System Operation

- Hot gas loop condensate systems utilize a hot gas serpentine coil that is routed through a condensate reservoir allowing water to be heated.
- This system may operate in conjunction with a wicking material that is partially submersed with warm condenser air passing through it for evaporation.

- This system also incorporates an overflow reservoir with heating element to ensure complete condensate removal.

Indicator Light

- Hot gas condensate removal system may also be equipped with a red indicator light for wicking material replacement, located in the rear of case.

Wicking Material Replacement

- See ***TROUBLESHOOTING (TO BE PERFORMED BY TRAINED SERVICE PROVIDERS ONLY) - PAGE 1*** section in manual.

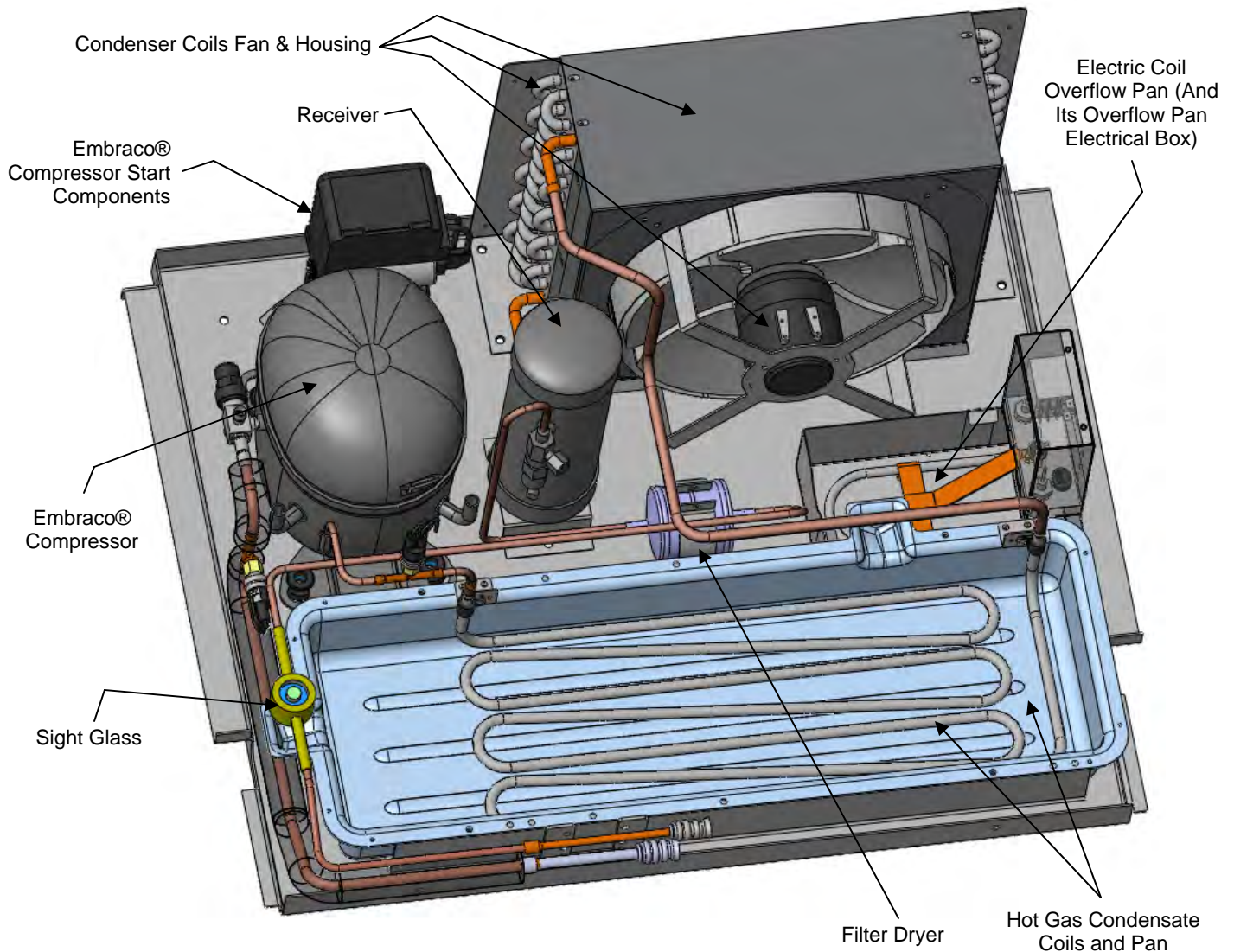

Hot Gas Loop Condensing System From Model HV48RSS.5536 Shown Above. Your Model May Vary.

Hot Gas Loop Condensate Units (Model HV3674RSS.5954, etc.)

System Operation

- Hot gas loop condensate systems utilize a hot gas serpentine coil that is routed through a condensate reservoir allowing water to be heated.
- This system may operate in conjunction with a wicking material that is partially submersed with warm condenser air passing through it for evaporation.

- This system also incorporates an overflow reservoir with heating element to ensure complete condensate removal.

Indicator Light

- Hot gas condensate removal system may also be equipped with a red indicator light for wicking material replacement, located in the rear of case.

Wicking Material Replacement

- See ***TROUBLESHOOTING (TO BE PERFORMED BY TRAINED SERVICE PROVIDERS ONLY) - PAGE 1*** section in manual.

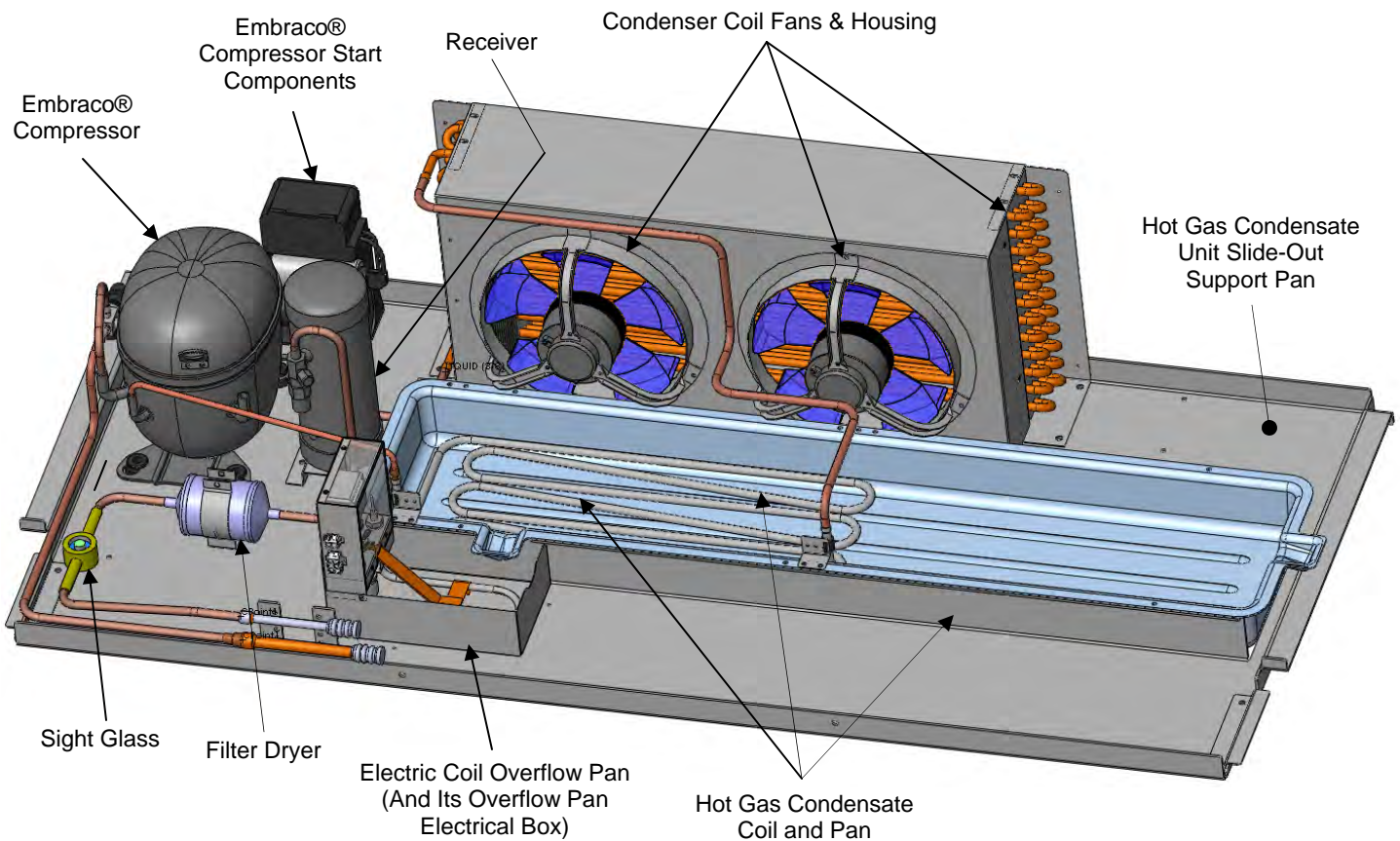

Hot Gas Loop Condensing System From Model HV3674RSS.5954 Shown Above. Your Model May Vary.

Rear Sliding Doors

- Each rear sliding door has a perforated Plexiglas plenum attached to it.
- Each perforated Plexiglas plenum door has metal door brackets attached to its sliding door.
- When door slides open (or closed), the Plexiglas plenum slides with it.

Removing the Rear Sliding Doors

Note: Doors are not interchangeable. There is an inner and outer door. The outer must be removed first and replaced last.

- The outer door is the right hand door (from the service side or rear of case). It can be identified by a stop located at the lower right hand corner to the inside of the case.
- Move doors toward the center of the case.
- Individually lift each door up toward the top of

the case; pivot the bottom of the door out.

- The metal door brackets are not connected to the perforated Plexiglas plenum; they will easily slide out from existing slots in plenum.
- Carefully set rear sliding doors down to prevent them from falling.
- Replace in reverse order they were removed.

Removing the Perforated Plexiglas Plenum

- Perforated Plexiglas plenums can be removed through the rear sliding doors' openings.
- Simply lift up and out.
- Reverse to reinstall. See illustration below.
- **Caution:** Gently set doors and plenums down to avoid marring, scraping, scratching or breakage.

Magnetic Air Filter

- Removable. Cleanable. Submersible. See below illustration.

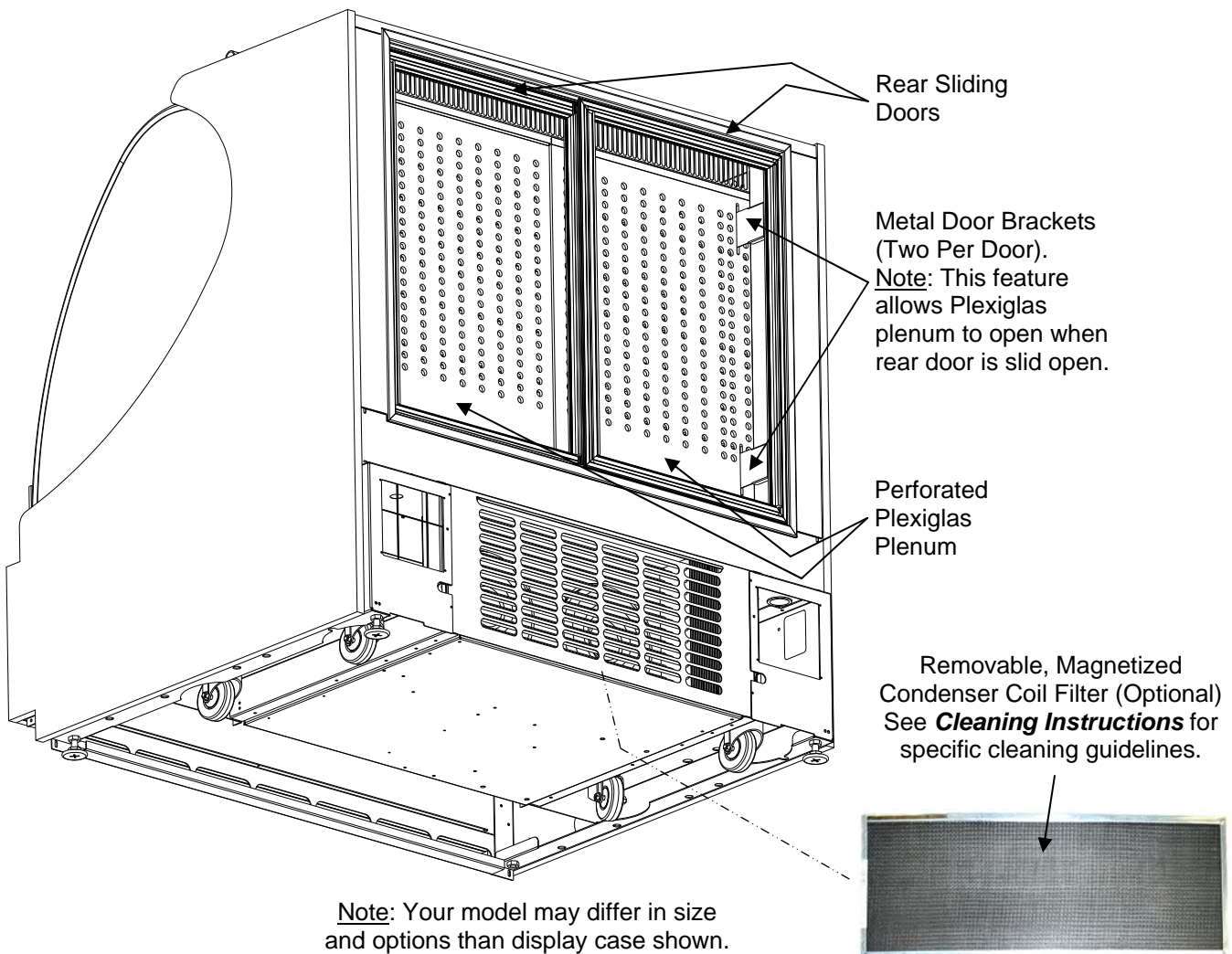

Note: Your model may differ in size and options than display case shown.

Medex® Storage Unit (Found on Model HV3674RSS.5954, etc.) Consists of The Following:

- Two (2) pull-out drawers which are strong enough to support icing buckets
- Two (2) pull-out supplies organizer drawers
- Two (2) storage doors
- See illustration below.

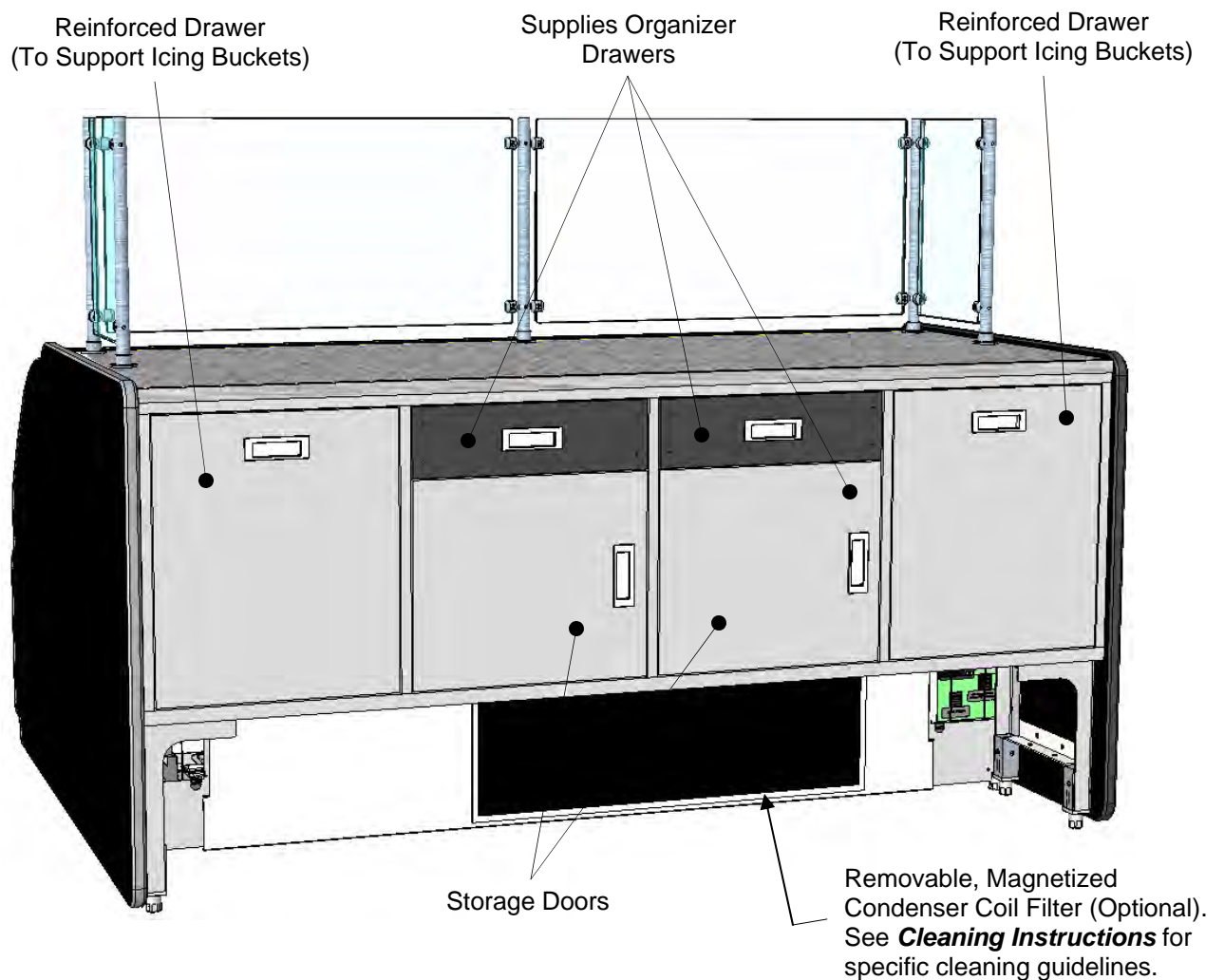

Model HV3674RSS.5954 Shown Above
Your Model May Differ

MAINTENANCE OF PATISSERIE AREA (MODEL HV36112RSS.4922B ONLY)

Start-Up, Evaporator Fan Access/Removal, Expansion Valve/Condensate Drain Access

Note: Photos and illustrations shown may not reflect every feature or option of your particular case.

- **Illustration #1:** Disconnect power from Case. Leads are provided at Right Rear, behind Rear Panel.
- **Photo #2:** From rear of case, use finger-hole to lift Solid Surface Deck; note that there may be slight maneuvering of decking necessary to entirely remove due to obstructions (thermostat or rear ledge).
- **Photo #3a:** View of Solid Surface Deck in slightly raised position.
- **Photo #3b:** Use both hands to slide toward case rear.
- **Photo #3c:** After raising front (at same level shown in 3a), move Decking forward, beyond front baffle.
- **Photo #3d:** Lift Decking up and out, taking care to not scrape or bump against glass or rest of case.
- **Photo #4:** Photo of insulated Sub-Deck after Solid Surface Decking has been entirely removed.

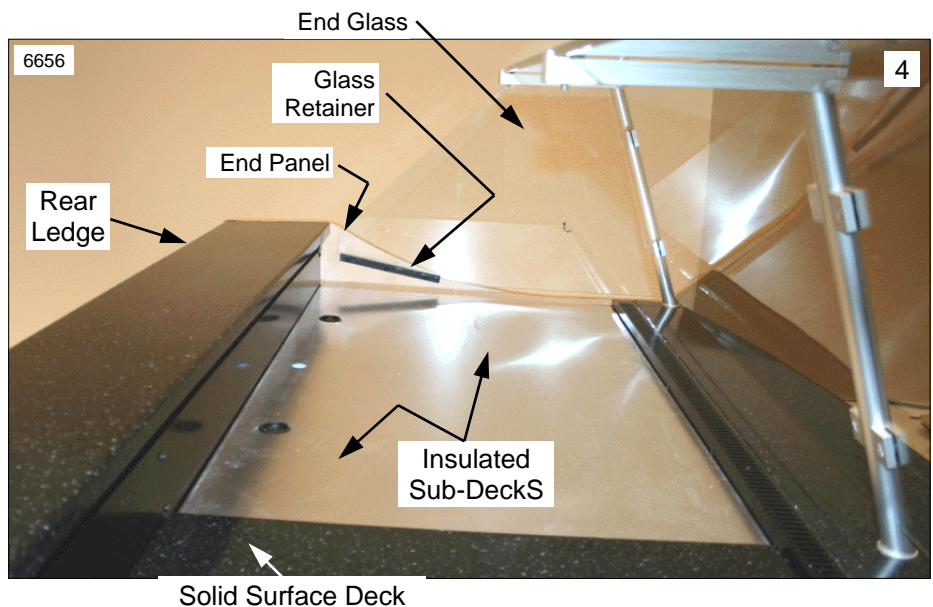
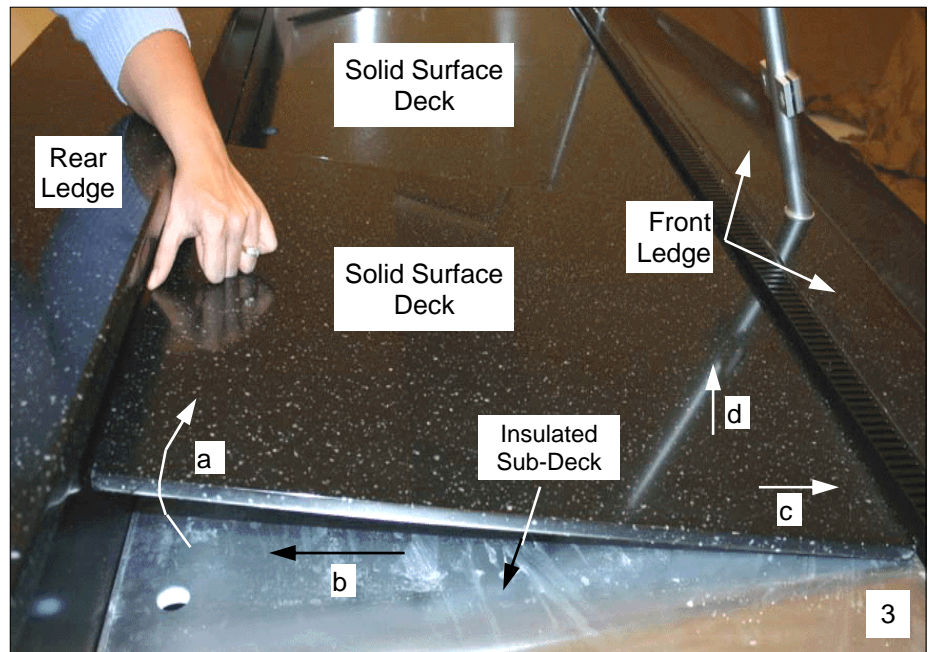
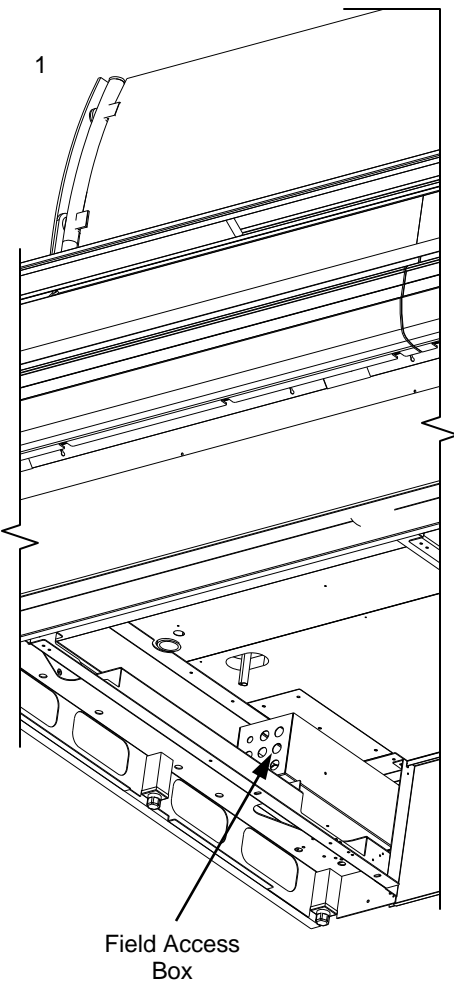

Start-Up, Evaporator Fan Access/Removal, Expansion Valve/Condensate Drain Access

- Photo #5: Sub-Deck being pulled up (and eventually out) to reveal Fan, Fan Housing & Shroud, etc.
- Illustration #6: View of Fan Housing, Fan Shroud, Fans, Drain, TXV Valves, etc. This is after the four Solid Surface Decks as well as the insulated Sub-Decks have been removed.

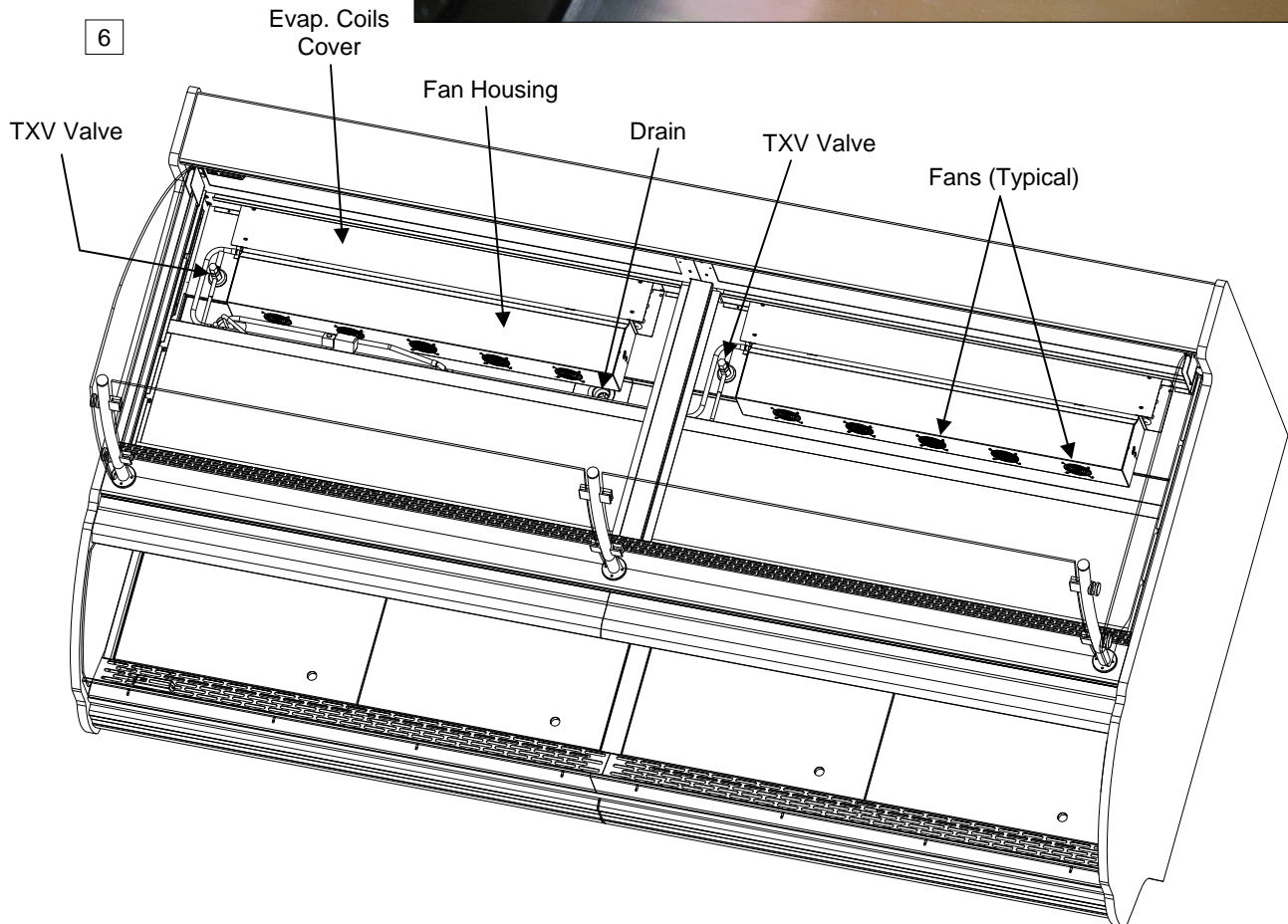

GENERAL CLEANING (TO BE PERFORMED BY STORE PERSONNEL)

AREA TO CLEAN	FREQ.	INSTRUCTIONS
Case Exterior	Daily	Acrylic: Clean acrylic sneeze guard with a mild soap and water solution and a soft cloth. Caution! Never use ammonia-based cleaners on acrylic. Incorrect cleaning agents or abrasive cleaning cloths cause surface to 'cloud' over time.
	Daily	Glass / Mirrors (Including Sliding Door Glass): Clean side glass, glass shelves, and mirrors with a household or commercial glass cleaner. Clean out door track with moist cloth.
	Daily	Shelves/Decking: Shelves and decking can be cleaned with a warm soap and water solution and soft cloth.
	Daily	Stainless Steel Sink (Certain Cases): Follow these instructions: <ul style="list-style-type: none"> • Wash with a solution of hand dishwashing liquid detergent and water or baking soda and water mix. Rinse and polish dry with paper towel or soft cloth. • Never use scouring powders or steel wool as they will scratch stainless steel. • Brighten by polishing with a cloth dipped in vinegar or in ammonia; sprinkle baking soda on sponge and rub gently; rinse. Polish dry with paper towel. • Remove streaks or heat stains from stainless steel by rubbing with club soda.
	Daily	End Panels, Front Panel, Toe-Kick, etc.: Wipe off all surfaces with warm water and mild soap solution and non-abrasive cloth.
	Weekly	Wood, Laminate and Painted Surfaces: Clean with mild soap and water solution and a soft cloth.
	Weekly to Monthly	Air Filter (With Magnetic Strip) on Rear Grille (Optional): <ul style="list-style-type: none"> • Depending upon environment, it may be necessary to clean filter as often as weekly. Filter MUST be cleaned at least monthly. • Remove from case. Submerge in warm, soapy water. Use soft-bristled brush to remove dust, grease and grime that collects on filter. Rinse thoroughly. After filter has dried, return to case. • See MAINTENANCE FUNDAMENTALS section in manual for illustrations.
Case Interior	Daily	Shelves/Deck: Shelves/Deck can be cleaned with a warm soap and water solution. For stubborn stains/residue, decks can be removed and cleaned with soap and water solution or submerged in hot, soapy water solution. Rinse thoroughly. Dry. Return to case.
	Weekly	Shelving Brackets / Air Return Grilles / Decking <ul style="list-style-type: none"> • Wipe off shelving brackets, air return grilles and decking with moist cloth. • Shelving brackets can be removed for more thorough cleaning. • Air return grilles can be removed for more thorough cleaning. • Decking is NOT to be removed by store personnel.
	Monthly	Condenser Coil: Vacuum or brush grille condenser coil at case front. Use metal or fiber brush to remove dust and dirt that can collect on condenser coils. Be careful not to damage the fins on the coil. See INSTALLATION section in manual for side panel removal information.

TROUBLESHOOTING (TO BE PERFORMED BY STORE PERSONNEL)

CONDITION	TROUBLESHOOTING
Case Not Lining Up	See Installation Section for instructions on properly aligning case (alongside other cases) and adjusting levelers (or rails).
Water Is On The Floor	Call service provider.
Fan Emits Excessive Noise	Call service provider.
Case Lights Are Not Working	Check that Light switch is in the <i>on</i> position.
	Check that ALL of the light cords and plugs are properly connected. See MAINTENANCE FUNDAMENTALS - STANDARD LIGHT FIXTURES or MAINTENANCE FUNDAMENTALS - LED LIGHTS section in manual.
	If case lights still do not come on, call service provider.
Case is Not Holding Proper Temperature	If a large amount of warm product was added to the case, it will take time for the temperature to adjust. Product must be pre-chilled before placing in case.
	Check that the case is not in the sun or near a heat or air-conditioning vent. See OVERVIEW / TECHNICAL INFORMATION / WARNINGS section in this manual for specifics.
	If case is located near front doors, temperature fluctuation can hinder unit's ability to maintain temperature.
	Check that air filter and condenser coil has been cleaned. See GENERAL CLEANING (TO BE PERFORMED BY STORE PERSONNEL) section in this manual for specifics.
	Check air return grilles (area at front of decking) for obstructions. DO NOT set product on air grilles as this will prevent proper airflow!
	If case still is not holding proper temperature, call service provider.

GENERAL CLEANING (TO BE PERFORMED BY TRAINED SERVICE PROVIDERS ONLY)

AREA TO CLEAN	FREQUENCY	INSTRUCTIONS
Case Interior	Monthly	<p><u>Evaporator Fan Shroud Area (Under Decking):</u> <i>Caution! Due to rotating fans in area, turn off case and disconnect plug from wall outlet before beginning fan shroud (and surrounding tub area) cleaning!</i> 1) Turn off power. 2) Remove decks from case. 3) Clean fan shroud area (and surrounding tub area) with moist cloth.</p>
	Quarterly	<p><u>Tub & Drain:</u> <i>Caution! Due to rotating fans in area, turn off case and disconnect plug from wall outlet before beginning tub & drain cleaning!</i> Vacuum tub under decks. Clean with soap and water solution. Wipe dry with clean cloth. Keep drain free of debris to prevent clogging.</p>

CONDITION	TROUBLESHOOTING
Case Not Lining Up	See Installation Section for instructions on properly aligning case (alongside other cases) and adjusting levelers.
Water Is On The Floor	<p>Caution! Water on flooring can cause much damage! Until cause is determined (and repaired), following these procedures:</p> <ul style="list-style-type: none"> • Use wet-dry vacuum (or mop & bucket) to remove standing water. • Use 'catch pans' for water to drain into. Swap out regularly until case has completely drained. <p>Note: See <i>Drain, Hose and Bracket Placement Illustrations</i> sheet in this manual for views of different condensate systems used in display cases.</p>
	Check that the drain trap is free of debris.
	Check that the drain hose is correctly positioned over condensate pan (or floor drain, for remote units).
	Check store conditions. To prevent condensation in NSF® Type 1 environments, maximum conditions are to be 55% humidity / 75° Fahrenheit. For NSF® Type 2, maximum conditions are to be 60% humidity / 80° Fahrenheit. See serial label (at case rear near main power switch) for NSF® Type of your case.
	Check condensate pan float for proper operation (Heat Rod Condensate System only).
	Check that condensate pan is properly plugged in or connected.
	<p>Caution! Condensate pan may be malfunctioning (Electrical Heat Rod Condensate system). If so, water will overflow pan and seep onto flooring causing damage! Until condensate pan is functioning (or is replaced), following these procedures:</p> <ul style="list-style-type: none"> • Use wet-dry vacuum (or mop & bucket) to remove standing water. • Use 'catch pans' for water to drain into. Swap out regularly until case has completely drained.
	<p>Caution! Disruption of power can cause water to overflow pan and seep onto flooring causing damage! Check that power to case is constant. Until power is restored, following these procedures:</p> <ul style="list-style-type: none"> • Use wet-dry vacuum (or mop & bucket) to remove standing water. • Use 'catch pans' for water to drainage. Swap out regularly until evaporation of case is complete (or until power is restored). <p>When power to case is restored, condensate pan should function properly and water will no longer overflow onto flooring.</p>
	<p>Caution! Wicking material may be dirty or worn and need replacement (Hot Gas Loop Condensate systems only).</p> <ul style="list-style-type: none"> • Slide refrigeration system out from under unit. • After refrigeration system has been carefully slid out from under unit, replace wicking material with new. If wicking material is not available, contact Structural Concepts®. See toll-free number at last page of this operating manual.

CONDITION	TROUBLESHOOTING
Fan Emits Excessive Noise	Check that the case is aligned, level and plumb.
	Check evaporator fan for cleanliness.
	Unplug/power off fan motors. Check motor shaft for bearing wear.
	Check that fan motors are securely mounted in brackets.
	Verify that fan blades are securely mounted to fan motor.
	Check that nothing is preventing blade rotation.
	Check that the fan shroud is properly secured.
Fans Are Not Working	Check that the MAIN power switch is on.
	Check that fans are plugged in at the fan shroud.
	Check for foreign material obstructing fan performance.
	Check that fan blades freely rotate within fan shrouds
	Check that power is going to fans
	Check that fan wiring is connected on terminal blocks.
Digital Control Display Is Blank	Check that the MAIN power switch is on.
	Check the circuit breaker box for tripped circuits.
System Not Operating	Check that the utility power is on.
	Check that the MAIN power switch is on.
	Check the circuit breaker box for tripped circuits.

CONDITION	TROUBLESHOOTING
Case Lights Are Not Working	Check that Light switch is in the <i>on</i> position.
	Check that ALL of the light cords and plugs are properly connected. See MAINTENANCE - LIGHT FIXTURES (LED LIGHT FIXTURES) section.
	Service Technicians Only: Check voltage at LED drivers. If voltage is entering but not exiting, LED driver may be faulty.
Control Display Is Flashing	See your case's serial label for your model's specified settings. See SERIAL LABEL LOCATION & INFORMATION LISTED / TECH INFO & SERVICE for label location, etc.
Case Is Not Holding Temperature	If a large amount of warm product was added to the case, it will take time for the temperature to adjust. Unit needs product to be pre-chilled.
	Temperature changes during defrost mode but will return to normal. Fourth LED will indicate defrost cycle in progress.
	Check that case is not in sun or near a heat or air-conditioning vent. See OVERVIEW AND WARNINGS section in manual for adverse conditions/spacing issue parameters.
	If case is located near front doors, temperature fluctuation can hinder unit's ability to maintain temperature. See OVERVIEW AND WARNINGS section in manual for adverse conditions/spacing issue parameters.
	Check that magnetic air filter (attached to rear grille) has been cleaned. See GENERAL CLEANING (TO BE PERFORMED BY STORE PERSONNEL) section in operating manual for instructions.
	Check that condenser coil has been cleaned.
	Check air return grilles for obstructions.
	Check sight glass for flashing and/or low charge.
	Check Set Point Temperature; it may be adjusted too high.
Condensing Unit Is Not Operating	Check that the power is turned on.
	Determine if temperature controller settings are properly set. See your case's serial label for your model's specified settings. See SERIAL LABEL LOCATION & INFORMATION LISTED / TECH INFO & SERVICE section in manual for label location, etc.

TROUBLESHOOTING (BY TRAINED SERVICE PROVIDERS ONLY) - CONDENSING SYSTEM

CONDITION	TROUBLESHOOTING
Head Pressure Too High	Check that the Condensing Coil is not dirty or covered.
	Check that Condensing Fans are working.
	Check that refrigerant is not overcharged.
	Check to verify that a non-condensable is not in the system.
	Check that Liquid Line Drier is not plugged.
	Check that there are no close-offs around Condensing Coil.
	Check Set Point Temp.; it may be adjusted too high.
	Check System Operating Temperatures.
	Check that Store Ambient Temperature isn't above maximum allowed. See <i>Overview and Warnings</i> Section.
Head Pressure Too Low	Check that Refrigerant Charge isn't too low.
	Check that Suction Pressure isn't too low.
	Check to verify that Compressor Valves aren't bad.

TROUBLESHOOTING (BY TRAINED SERVICE PROVIDERS ONLY) - EVAPORATOR SYSTEM

CONDITION	TROUBLESHOOTING
Low Suction Pressure	Check that the Refrigerant doesn't have a low charge.
	Check that Expansion Valve (TXV Valve) isn't restricted.
	Check that Liquid Line or Filter isn't restricted.
	Check that Evaporator Motors are working.
	Check that High Superheat doesn't need adjusting.
	Check that the Thermostatic Element charge isn't depleted.
	Check that there is air no seepage of air around Condensing Coil.
	Check that the Coil is not iced up.
High Suction Pressure	Check that Refrigerant Charge isn't too high.
	Check that Compressor Valves aren't bad.
	Check that the Cooling Load isn't high.
	Check that Superheat Adjustment isn't low.
	Check TXV Bulb Installation a. Poor thermal contact. b. Warm location.
	Check Compressor: Low capacity means it is undersized for its application.

PREVENTIVE MAINTENANCE (TO BE PERFORMED BY TRAINED SERVICE PROVIDER)

WARNING! TURN OFF CASE BEFORE PERFORMING PREVENTIVE MAINTENANCE!

PREVENTIVE MAINTENANCE	FREQ.	INSTRUCTIONS
Case Exterior	Quarterly	<p><u>Condensing Coil:</u></p> <ul style="list-style-type: none"> • Remove panel to access area by lifting up and off or by screw removal (depending on case). • Use air pressure or industrial strength vacuum; clean dust and dirt that may collect on the Condenser Coil. • Caution! Airborne dust can contaminating food! Use wet rags to cover area where air pressure is blowing. • Warning! Coil fins are sharp. Handle with care! • Return panel to case.
	Quarterly	<p><u>Refrigeration Package/Compressor Area:</u> <i>Caution! Be certain to disconnect power from case before cleaning Refrigeration Package!</i></p> <ul style="list-style-type: none"> • Warning! Condensate Pan Is HOT! Disconnect power from case and allow to cool before cleaning condensate pan! • Slide/Roll compressor package out from under case. • See REFRIGERATION FUNDAMENTALS section for in-depth instructions on accessing the condensate pan. • Use a scrub-brush and a de-scaling solution such as CLR® (to prevent corrosion, lime and rust). Follow instructions as to proper dilution, safety precautions and scrubbing method. • Electric heater coil condensate pans can be removed and cleaned. • After thoroughly cleaning pan with scrub-brush and solution, rinse thoroughly with clean water (in spray bottle) and wipe dry with sponge or paper towel. • Use moist cloth to wipe off dust & debris that collects on various parts (fans, sight glass, overflow pan, etc.). • Slide refrigeration assembly back under case. • Replace front panel and lower grille via hooks (no screws required).
	Quarterly	<p><u>Under Case Cleaning:</u> Once refrigeration package is clear of unit, vacuum under case to remove dust and dirt that may collect under case.</p>
Case Interior	Quarterly	<p><u>Tub Area (Evaporator Coil, Drain, Fans, Brackets):</u></p> <p>Caution! Disconnect power from the case before cleaning tub, coil, fan, motor and drain area!</p> <ul style="list-style-type: none"> • Use vacuum to clean entire area. • After vacuuming, clean area with warm water, clean cloth, and mild soap solution. • Remove any debris that may clog drain. • Wipe down fan blades, motors and brackets with moist cloth.
	Quarterly	<p><u>Honeycomb:</u> Check honeycomb air diffuser to determine if it is dirty. If dirty, remove from case. See MAINTENANCE FUNDAMENTALS - HONEYCOMB AIR DIFFUSERS (SERVICE TECHNICIANS ONLY) section of this manual (next page) for cleaning specifics.</p>

Honeycomb Air Diffuser Removal

See **PREVENTIVE MAINTENANCE (TO BE PERFORMED BY TRAINED SERVICE PROVIDER)** section in this manual for cleaning frequency.

A. Wedge a non-metallic device of suitable strength (such as a ballpoint pen) between the honeycomb and the end panel.

Caution! Use care not to dislodge the heating wire (that prevents condensation on the lamp assembly).

B. Apply pressure to collapse the honeycomb to allow it to be pulled out of honeycomb retainer.

C. Carefully pry downward and away from the honeycomb retainer.

Clean honeycomb with warm water and soap solution. Submerge if necessary. Use brush to dislodge stubborn or sticky residue. Dry by using vacuum's blow mode (vs. suction mode).

Honeycomb Air Diffuser Installation

D. Squeeze honeycomb to allow it to fit into the honeycomb retainer.

E. Carefully slide honeycomb into place.

F. Adjust honeycomb so that it fits flat against retainer. It must not be wavy or out of position.

Note: For honeycomb air diffusers in other locations, these same general instructions apply.

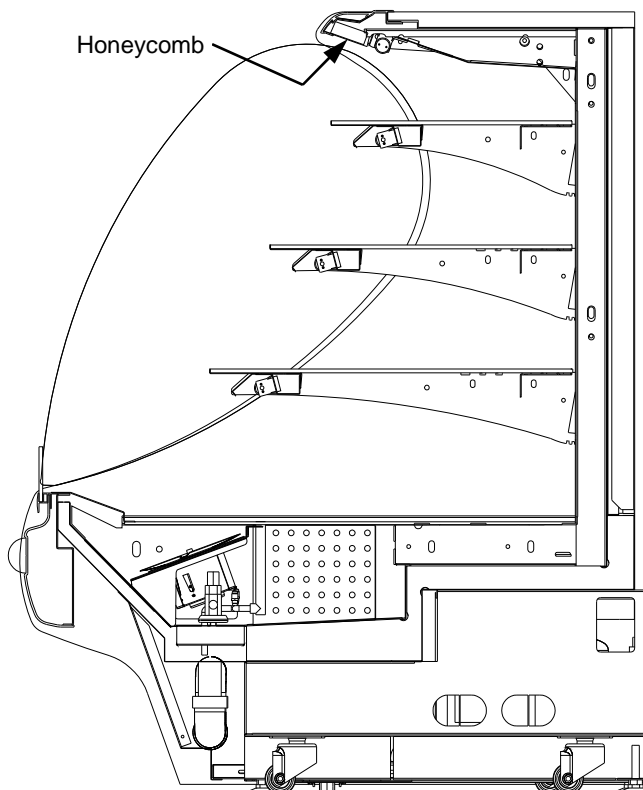
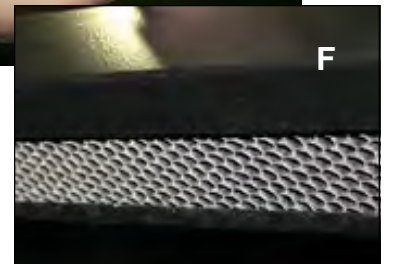
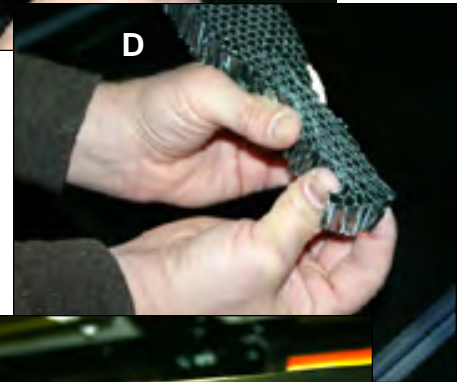

Serial Label Location & Information Listed / Technical Information & Service

- Serial labels are located near the electrical access on your case.
- Serial labels contain electrical, temperature & refrigeration information, as well as regulatory standards to which the case conforms.
- For additional technical information and service, see the *TECHNICAL SERVICE* page in this manual for instructions on contacting Structural Concepts' Technical Service Department.
- See images below for samples of both refrigerated and non-refrigerated serial labels.



888 E. Porter Rd · Muskegon, MI 49441

ENCORE[®] MODEL HV74RSS SCROLL
SERIES SERIAL NO.

FOR PARTS AND SERVICE
CALL 1-800-433-9489



3048256
CONFORMS TO UL STD 471
CONFORMS TO NSF STD 7
CERTIFIED TO CAN/CSA
STD C22.2 NO 120

ELECTRICAL RATING 120/1/60 24A
REFRIGERANT R404A AMOUNT ?? OZ
DESIGN PRESSURE HIGH 450 LOW 200
MINIMUM CIRCUIT 30A
MAXIMUM OVERCURRENT 30A

SAMPLE ONLY

Super Heat Temp	8-10°F
BTUH Requirements	9,738 BTUH @ 20° F SST
Defrost	6 defrosts per day, 45° F termination, 45 min. failsafe

SAMPLE ONLY

SAMPLE ONLY

----- Sample Serial Label For Refrigerated Case -----



888 E. Porter Rd · Muskegon, MI 49441

Addenda[®] PC5682 txtRemote
txtSerialNumber

120 VOLTS 60 HZ SINGLE PHASE 1.84AMP
FOR PARTS OR SERVICE CALL
STRUCTURAL CONCEPTS
AT
1-800-433-9489



3048256
CONFORMS TO UL STD 65
CERTIFIED TO CAN/CSA
STD C22.2 NO 120

SAMPLE ONLY

----- Sample Serial Label For Non-Refrigerated Case -----

CAREL

ir33 platform

Integrated Electronic
Microprocessor Controller



Programming The Instrument

To Modify The Setpoint

Set Press and hold the "SET" key for at least 1 second.

aux **def** 2. Use arrow keys **▲** **▼** on temperature controller to increase (or decrease) the setpoint.

Set 3. Quickly press and release the "SET" key again.

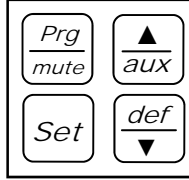

To Modify Defrost, Differential, Other Parameters

Prg/mute **Set** 1. Press & hold "Prg" & "SET" keys together for five (5) seconds; display will flash "0", representing password prompt.

Set 2. Confirm by pressing "SET" key.

aux **def** 3. Press **▲** or **▼** to reach the category to be modified.

Set 4. Press "SET" to modify this selected parameter.

aux **def** 5. Increase or decrease the value using the **▲** or **▼** button respectively.

Set 6. Press the "SET" key to temporarily save the new value and return to the display of the parameter.

Prg/mute 7. Press & hold the "Prg" key for at least 5 seconds to save changes. This action will also mute the audible alarm (buzzer) & deactivate the alarm relay.

How To Change Reading From Fahrenheit (°F) To Celsius (°C)

Prg/mute **Set** 1. Press and hold "Prg" and "SET" keys together for at least 5 seconds; display will show "0" (password prompt).

Set 2. Confirm by pressing "SET" key.

aux **def** 3. Press **▲** or **▼** until reaching the parameter "/ 5".

Set 4. Press "SET" to modify this selected parameter.

aux **def** 5. Press **▲** or **▼** to change value to desired setting: "0" for Celsius (°C) or "1" for Fahrenheit (°F).

Set 6. Press "SET" key to temporarily save the new value and return to the display of the parameter.

Prg/mute 7. Press & hold "Prg" key for at least 5 seconds to save changes. **Note! All values will automatically convert to new scale. No conversion is required.**

Warning! Save Your Parameter Settings!

1. To store the new parameter values, PRESS and HOLD the "Prg" key for at least 5 seconds.
2. All modifications made to parameters will be lost if you do NOT press a button within 60 seconds. Should this "timeout" occur, normal operational settings (prior to modifications being made) will resume.
3. If the instrument is switched off before pressing the "Prg" key, all modifications to parameters will be lost.

def **To Activate Manual Defrost**
Press and hold "def" key for at least 5 seconds.

aux **To Activate / Deactivate Auxiliary Output**
Press and hold the "aux" key for 1 second.

Prg/mute **aux** **To Reset Any Alarms With Manual Reset**
Press and hold the "Prg" and "aux" key for at least 1 second.

CAREL

ir33 platform
**Integrated Electronic
 Microprocessor Controller**



User Interface - Display

ICON	FUNCTION	DESCRIPTION	Normal operation			Start up
			ON	OFF	BLINK	
	COMPRESSOR	ON when the compressor starts. Flashes when the activation of the compressor is delayed by safety times.	Compressor on	Compressor off	awaiting activation	
	FAN	ON when the fan starts. Flashes when the activation of the fan is prevented due to external disabling or procedures in progress.	Fan on	Fan off	awaiting activation	
	DEFROST	ON when the defrost is activated. Flashes when the activation of the defrost is prevented due to external disabling or procedures in progress.	Defrost in progress	Defrost not in progress	awaiting activation	
	AUX	Flashes if the anti-sweat heater function is active, ON when the auxiliary output (1 and/or 2) selected as AUX (or LIGHT in firmware version 3.6) is activated.	AUX auxiliary output active (version 3.6 light auxiliary output active)	AUX auxiliary output not active	Anti-sweat heater function active	
	ALARM	ON following pre-activation of the delayed external digital input alarm. Flashes in the event of alarms during normal operation (e.g. high/low temperature) or in the event of alarms from an immediate or delayed external digital input.	Delayed external alarm (before the time 'A7' elapses)	No alarm present	Alarms in norm. operation (e.g. High/low temperature) or immediate or delayed alarm from external digital input	
	CLOCK	ON if at least one timed defrost has been set. At start-up, comes ON for a few seconds to indicate that the Real Time Clock is fitted.	If at least 1 timed defrost event has been set	No timed defrost event set	Alarm clock	ON if real-time clock present
	LIGHT	Flashes if the anti-sweat heater function is active, ON when the auxiliary output (1 and/or 2) selected as LIGHT is activated (in firmware version 3.6 it does not flash in anti-sweat heater mode and comes on when the dead band output is active).	Light auxiliary output on (version 3.6 dead band auxiliary output active)	Light auxiliary output off	Anti-sweat heater function active (version 3.6 does not flash in anti-sweat heater mode)	
	SERVICE	Flashes in the event of malfunctions, for example E2PROM errors or probe faults.		No malfunction	Malfunction (e.g. E2PROM error or probe fault). Contact service	
	CONTINUOUS CYCLE	ON when the CONTINUOUS CYCLE function is activated. Flashes if the activation of the function is prevented due to external disabling or procedures in progress (E.g.: minimum compressor OFF time).	CONTINUOUS CYCLE operation activated	CONTINUOUS CYCLE function not activated	CONTINUOUS CYCLE operation requested	

Summary Table of Alarm and Signals: Display, Buzzer and Relay

Code	Icon on the display	Alarm relay	Buzzer	Reset	Description
rE	flashing	on	on	automatic	virtual control probe fault
E0	flashing	off	off	automatic	room probe S1 fault
E1	flashing	off	off	automatic	defrost probe S2 fault
E2	flashing	off	off	automatic	probe S3 fault
E3	flashing	off	off	automatic	probe S4 fault
E4	flashing	off	off	automatic	probe S5 fault
'	No	off	off	automatic	probe not enabled
LO	flashing	on	on	automatic	low temperature alarm
HI	flashing	on	on	automatic	high temperature alarm
AFr	flashing	on	on	manual	antifreeze alarm
IA	flashing	on	on	automatic	immediate alarm from external contact
dA	flashing	on	on	automatic	delayed alarm from external contact
dEF	on	off	off	automatic	defrost running
Ed1	No	off	off	automatic/manual	defrost on evaporator 1 ended by timeout
Ed2	No	off	off	automatic/manual	defrost on evaporator 2 ended by timeout
Pd	flashing	on	on	automatic/manual	maximum pump down time alarm
LP	flashing	on	on	automatic/manual	low pressure alarm
AtS	flashing	on	on	automatic/manual	autostart in pump down
cht	No	off	off	automatic/manual	high condenser temperature pre-alarm
CHT	flashing	on	on	manual	high condenser temperature alarm
dor	flashing	on	on	automatic	door open too long alarm
EE	flashing	off	off	automatic	E2prom error, unit parameters
EF	flashing	off	off	automatic	E2prom error, operating parameters
ccb	Signal				start continuous cycle request
ccE	Signal				end continuous cycle request
dFb	Signal				start defrost call
dFE	Signal				end defrost call
On	Signal				switch ON
off	Signal				switch OFF
rES	Signal				reset alarms w/manual reset / reset HACCP alarms / reset temp. monitoring

CAREL

ir33 platform

Integrated Electronic
Microprocessor Controller



Summary Table of Operating Parameters

CODE	PARAMETER	UOM*	TYPE	MINIMUM	MAXIMUM	DEFAULT
/5	Select Celsius (°C) or Fahrenheit (°F)	flag	C	0	1	For Case Specific Defaults See Serial Label Located Near Electrical Access On Your Case. For Additional Technical Information Call Structural Concepts Technical Service Dept. at 1(800) 433.9489
/c1	Calibration of probe 1	°C/°F	C	-20	20	
/c2	Calibration of probe 2	°C/°F	C	-20	20	
St	Temperature set point	°C/°F	F	r2	r1	
rd	Control delta	°C/°F	F	20	0.1	
dl	Interval between defrosts	hours	F	0	250	
dt1	End defrost temperature, evaporator	°C/°F	F	-50	200	
dP1	Maximum defrost duration, evaporator	min	F	1	250	
d6	Display on hold during defrost	-	C	0	2	
dd	Dripping time after defrost	min	F	0	15	
d/1	Display of defrost probe 1	°C/°F	F	-	-	

* Unit Of Measure

STRUCTURAL CONCEPTS CORPORATION TECHNICAL SERVICE
PHONE NUMBER: 1.800.433.9489 or For Your Master Service Agent See
WWW.STRUCTURALCONCEPTS.COM/Contact/Master_Service_Agents.asp

LIMITED WARRANTY

All sales by Structural Concepts Corporation (SCC) are subject to the following limited warranty. "Goods" refers to the product or products being sold by SCC.

Warranty Scope: Warranty is for equipment sold in the United States, Canada, Mexico and Puerto Rico. Equipment sold elsewhere may carry modified warranty.

Warranty; Remedies; Limitations. The limit of liability of SCC toward the exchange cost of the original compressor motor (and/or any other components) is one year parts and labor. If any Goods are found to be of faulty material or workmanship within one year of the original F.O.B. unit shipment, SCC will, at its option (after inspection by an authorized representative), replace or pay the reasonable cost of replacement of the faulty Goods. If warranty claim is not made within this one year time period, SCC is not bound to warrant Goods. A motor-compressor (and/or any other components) replaced during the warranty shall not exceed manufacturer's current established wholesaler's exchange price. If replacement motor-compressor (and/or other components) is available via storage facility, parts truck, etc., SCC mandates that readily accessible replacement components be used toward repair of Goods; in such instances, SCC will replace such equipment (at its own expense) after confirmation of its use/placement on defective unit. SCC shall not be charged an additional fee, up-charge or expense for such replacement Goods. If SCC is unable to repair or replace the defective Goods, SCC shall issue a credit to the Purchaser for full or partial purchase price, as SCC shall determine. The replacement or payment in the manner described above shall be the sole and exclusive remedy to Purchaser for a breach of this warranty. If any Goods are defective or fail to conform to this warranty, SCC will furnish instructions for their disposition. No Goods shall be returned to SCC without its prior consent.

SCC's liability for any defect in the Goods shall not exceed the purchase price of the Goods. SCC SHALL HAVE NO LIABILITY TO PURCHASE FOR CONSEQUENTIAL DAMAGES OF ANY KIND WHATSOEVER, INCLUDING, BUT NOT LIMITED TO, PERSONAL INJURY, PROPERTY DAMAGE, LOST PROFITS, OR OTHER ECONOMIC INJURY DUE TO ANY DEFECT IN THE GOODS OR ANY BREACH OF SCC, SCC SHALL NOT BE LIABLE TO THE PURCHASER IN TORT FOR ANY NEGLIGENT DESIGN OR MANUFACTURE OF THE GOODS, OR FOR THE OMISSION OF ANY WARNING THEREFROM.

SCC shall have no obligation or liability under this warranty for claims arising from any other party's (including Purchaser's) negligence or misuse of the Goods or environmental conditions. This warranty does not apply to any claim or damage arising from or caused by improper storage, handling, installation, maintenance, or from fire, flood, accidents, structural defects, building settlement or movement, acts of God, or other causes beyond SCC's control.

Except as expressly stated herein, SCC makes no warranty, express, implied, statutory or otherwise as to any parts or goods not manufactured by SCC. SCC shall warrant such parts or Goods only (I) against such defects, (II) for such periods of time, and (III) with such remedies, as are expressly warranted by the manufacturer of such parts or Goods. Notwithstanding the foregoing, any warranty with respect to such parts or Goods and any remedies available as a result of a breach thereof shall be subject to all of the procedures, limitations, and exclusions set forth herein.

THE WARRANTIES HEREIN ARE IN LIEU OF ALL WARRANTIES, EXPRESS, IMPLIED, STATUTORY, OR OTHERWISE. IN PARTICULAR, SCC MAKES NO WARRANTY OF MERCHANTABILITY OR FITNESS FOR A PARTICULAR PURPOSE.

No representative, agent or dealer of SCC has authority to modify, expand, or extend this Warranty, to waive any of the limitations or exclusions, or to make any different or additional warranties with respect to Goods.

Period of Limitations. No claim, suit or other proceeding may be brought by Purchaser for any breach of the foregoing warranty or this Agreement by SCC or in any way arising out of this Agreement or relating to the Goods after one year from the date of the breach. In the interpretation of this limitation on action for a breach by SCC, it is expressly agreed that there are no warranties of future performance of the goods that would extend that period of limitation herein contained for bringing an action.

Indemnifications. Purchaser agrees to indemnify, hold harmless, and defend SCC if so requested, from any and all liabilities, as defined herein, suffered, or incurred by SCC as a result of, or in connection with, any act, omission, or use of the Goods by Purchaser, its employees or customers, or any breach of this Agreement by Purchaser. Liabilities shall include all costs, claims, damages, judgments, and expenses (including reasonable attorney fees and costs).

Remedies of SCC. SCC's rights and remedies shall be cumulative and may be exercised from time to time. In a proceeding or action relating to the breach of this Agreement by Purchaser, Purchaser shall reimburse SCC for reasonable costs and attorney's fees incurred by SCC. No waiver by SCC of any breach of Purchaser shall be effective unless in writing nor operate as a waiver of any other breach of the same term thereafter. SCC shall not lose any right because it has not exercised it in the past.

Applicable Law. This Agreement is made in Michigan and shall be governed by and interpreted according to Michigan law. Any lawsuit arising out of this Agreement or the Goods may be handled by a federal or state court whose district includes Muskegon County, Michigan, and Purchaser consents that such court shall have personal jurisdiction over Purchaser.

Miscellaneous. If any provision of this Agreement is found to be invalid or unenforceable under any law, the provision shall be ineffective to that extent and for the duration of the illegality, but the remaining provisions shall be unaffected. Purchaser shall not assign any of its rights nor delegate any of its obligations under this Agreement without prior written consent of SCC. This Agreement shall be binding upon and inure to the benefit of SCC and Purchaser and each of their legal representatives, successors and assigns.

SCC warrants its products to be free of defects in materials and workmanship under normal use and service for a period of one (1) year from the date of delivery.

This warranty is extended only to the original purchaser for use of the Goods. It does not cover normal wear parts such as plastic tongs, tong holders, tong cables, bag holders, or acrylic dividers.

General Conditions. All service labor and/or parts charges are subject to approval by SCC. Contact the Customer Service Department in writing or call 231-798-8888.

All claims must contain the following information: (1) model & serial code number of equipment; (2) the date and place of installation; (3) the name and address of the agency which performed the installation; (4) the date of the equipment failure; and (5) a complete description of the equipment failure and all circumstances relating to that failure.

Once the claim has been determined to be a true warranty claim by SCC's Customer Service Department, the following procedure will be taken: (1) replacement parts will be sent at no charge from SCC on a freight prepaid basis; (2) reimbursement for service labor will be paid if the following conditions have been met - (a) prior approval of service agency was awarded from the Customer Service Department; and (b) an itemized statement of all labor charges incurred is received by the Customer Service Department. The cost of the service labor reimbursement will be based on straight time rates and reasonable time for the repair of the defect.

If problems occur with any compressor, notify SCC's Customer Service Department immediately. Any attempt to repair or alter the unit without prior consent from the Customer Service Department will render any warranty claim null and void. This warranty and protection plan does not apply to any condensing unit or any part thereof which has been subject to accident, negligence, misuse, or abuse, or which has not been operated in accordance with the manufacturer's recommendations or if the serial number of the unit has been altered, defaced, or removed.

One Year Limit of Liability. After SCC's one-year parts and labor warranty on the original F.O.B. unit has expired, SCC is not liable for either the equipment or labor costs of repairing or replacing the motor compressor, nor any other components that were included in the original F.O.B. unit.