

ENCORE[®] SERIES

INSTALLATION AND OPERATING MANUAL

PN 99593

SELF-SERVICE NON-REFRIGERATED BAKERY MERCHANDISER



Model HVAD38SS.....	38" L * x 41" D x 51" H
Model HVAD48SS.....	50" L * x 41" D x 51" H
Model HVAD56SS.....	58" L * x 41" D x 51" H
Model HVAD74SS.....	76" L * x 41" D x 51" H

**Without 1" end panels.*



TABLE OF CONTENTS

OVERVIEW / COMPLIANCE / WARNINGS / PRECAUTIONS / WIRING DIAGRAM	3
INSTALLATION: REMOVAL FROM SKID / POSITIONING AND LEVELING	4
INSTALLATION, CONTINUED: BOLTING ADJOINED UNITS / ELECTRICAL CONNECTIONS	5
START-UP AND OPERATION	6
MAINTENANCE FUNDAMENTALS: SHELF ASSEMBLY	7
MAINTENANCE FUNDAMENTALS, CONTINUED: LIGHT FIXTURES	8
SERIAL LABEL & LOCATION / TECHNICAL INFORMATION / ADD'L INFORMATION	9
TROUBLESHOOTING	10
CLEANING SCHEDULE.....	11
TECHNICAL SERVICE CONTACT INFORMATION & WARRANTY INFORMATION	12

OVERVIEW

- These cases should be installed and operated according to these instructions to insure proper performance. Improper use will void warranty.
- This unit is designed for the display of products in ambient store conditions where temperatures and humidity are maintained at a maximum of 75 °F and 55% relative humidity.

COMPLIANCE

- Performance issues when in violation of applicable NEC, federal, state or local electrical codes are not covered by warranty.
- See compliance specifics below.

WARNINGS

- Following are important warnings to prevent injury or death.
- Please read carefully!

PRECAUTIONS

- Following are important precautions to prevent damage to unit or merchandise.
- Please read carefully!

WIRING DIAGRAM

- Each case has its own wiring diagram folded and in its own packet.
- Wiring diagram placement may vary; it may be placed near ballast box, field wiring box, raceway cover, or other related location.



**ATTENTION
INSTALLER**

COMPLIANCE
This equipment **MUST** be installed in compliance with all applicable NEC, federal, state and local electrical codes.



WARNING
Risk of electric shock.
Disconnect ALL ELECTRICAL SOURCES before servicing.

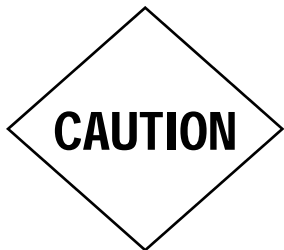

CAUTION! LAMP REPLACEMENT GUIDELINES
LED lamps reflect specific size, shape and overall design. Any replacements must meet factory specifications.
Fluorescent lamps have been treated to resist breakage and must be replaced with similarly treated lamps.

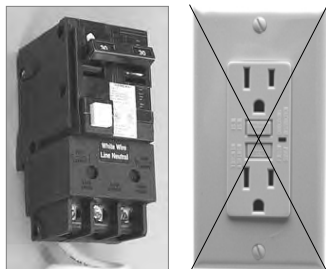

CAUTION
If N.E.C. (National Electric Code) or your local code requires GFCI (Ground Fault Circuit Interrupter) protection, the use of a GFCI breaker is strongly recommended.

INSTALLATION: REMOVAL FROM SKID / POSITIONING AND LEVELING

Installation

Note: Units shown may not depict an exact representation of your particular unit being installed.

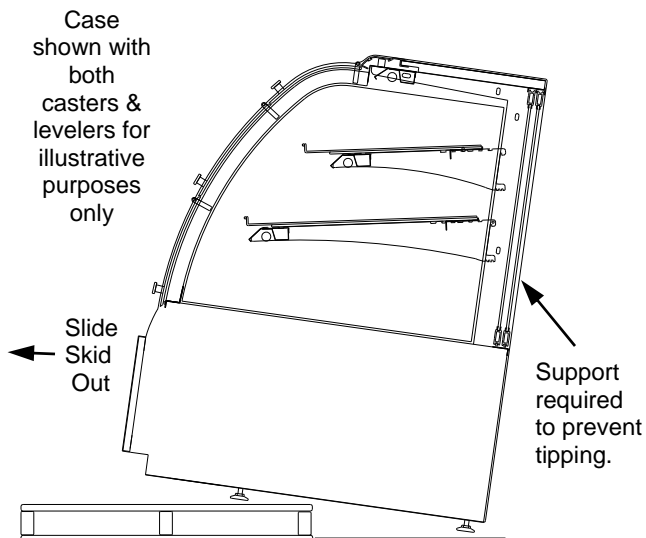

1. Remove Unit From Skid

Caution: case must always remain supported or center of gravity will allow case to fall. Slide unit to rear of skid and tip backward off skid.

2. Position and Level Units

Position Units. Align multiple units carefully in areas A, B, and C.

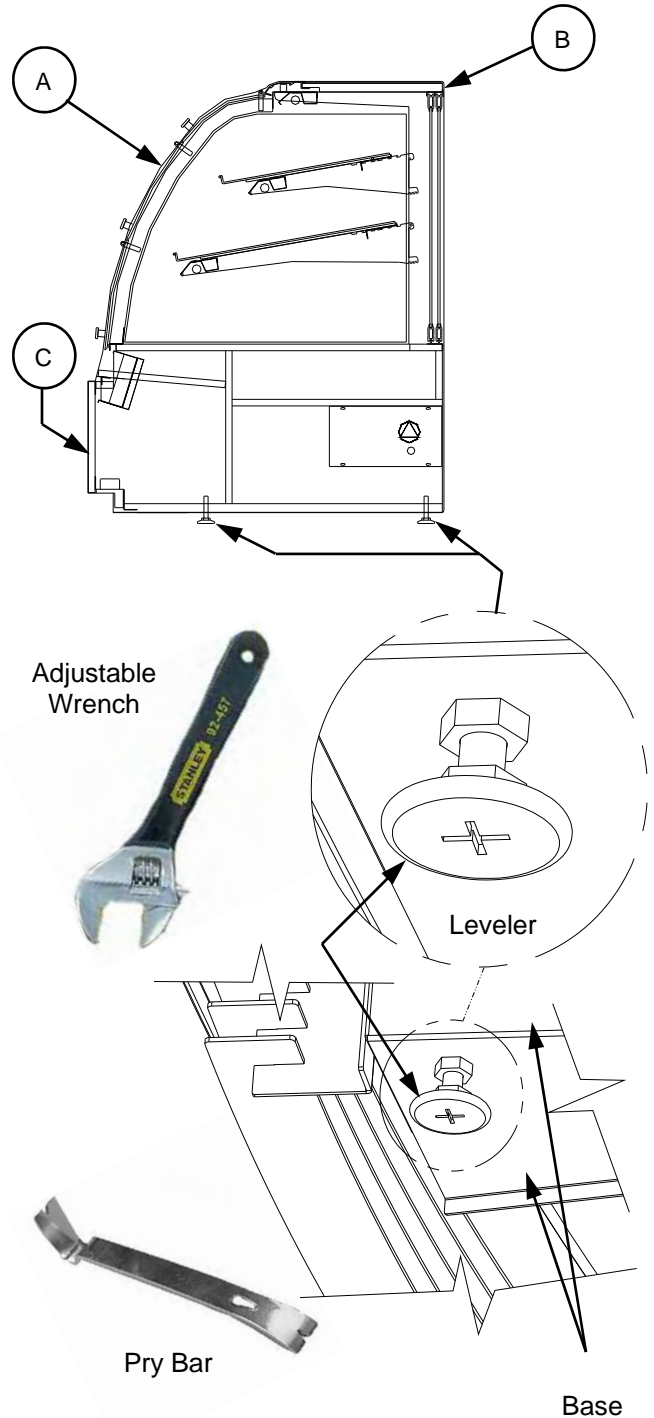

Installation

Note: Units shown may not depict an exact representation of your particular unit being installed.

3. Bolting Adjoined Units

- View shown is after removal of end panel.
- Units are bolted together near locations shown.
- 1/4-20 x 2 1/2" nuts & bolts for locations 1-4.
- 1 1/2" long wood screws in random locations to be used for item 5.

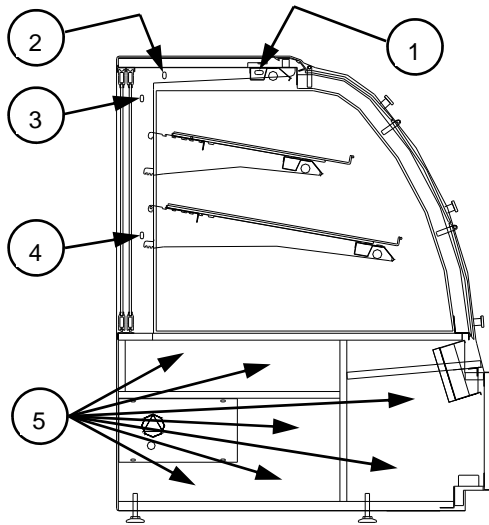

4. Electrical Connections

Field wiring hook-up / electrical access locations are shown in the plan view below.

- 120V single phase leads are provided.
- See Electrical Specifications Sheet for more detailed information.

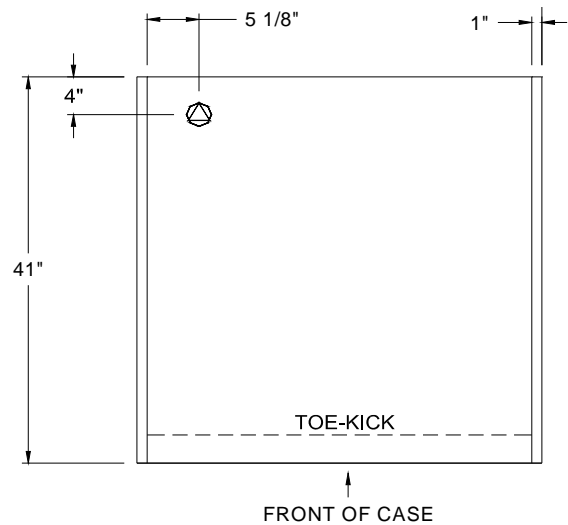

START-UP AND OPERATION

1. Merchandiser Start-Up

- Turn on the lights. All of the lights should come on at the same time. First time lighting may require a short warm up period for the bulbs. Slightly dim or a flickering of new bulbs is normal.
- If lights do not turn on, check all of the raceway plugs. The lighting is wired in series so **all lights must be plugged in or receptacles capped** in order for the case to light.

2. Raise the Curved Acrylic Doors

- To raise the curved acrylic doors, secure the lift handle extrusion on the bottom edge of the doors and lift up.
- **Caution:** Gently return doors to original positions. If doors are allowed to drop, they can injure fingers.

3. Removing the Rear Doors

- See illustration at right.
- Move rear doors toward the center of case.
- Individually lift each door up toward top of case and pivot the bottom of the door out.
- **Caution:** Gently set doors down to avoid marring, scraping or breakage.

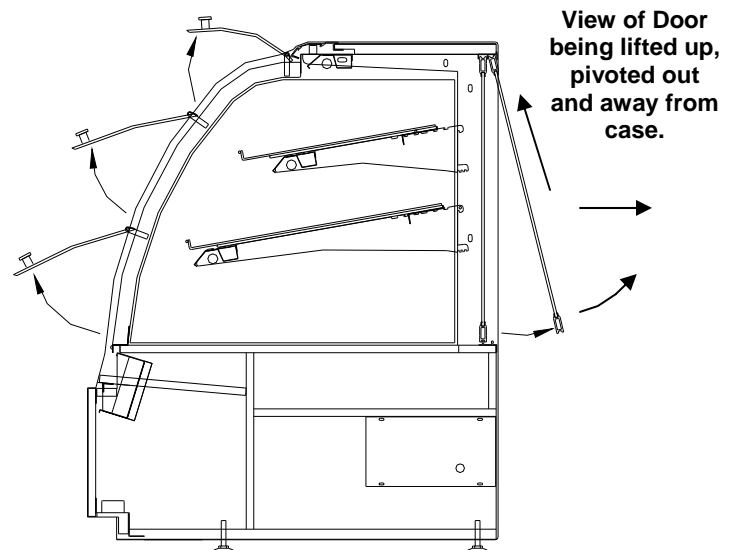
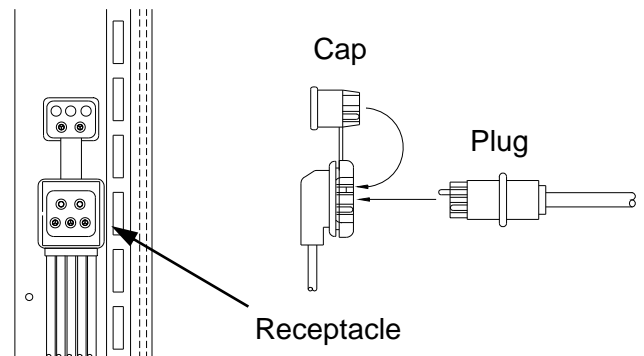
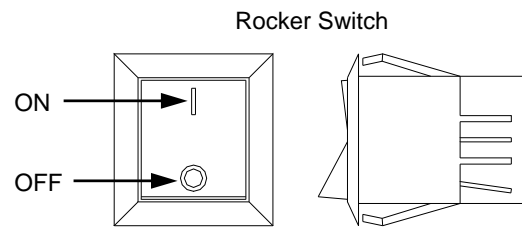

1. Shelf Assembly Removal

- Remove glass shelves
- For lighted shelving, unplug the light cord.
- Lift light shelf straight up to separate from brackets.
- Remove rear shelf support
- Remove brackets. Note it may be necessary to remove the nylon shipping bracket retainer. A pair of pliers will be required to accomplish this task.
- Reassemble shelf in reverse order it was disassembled.

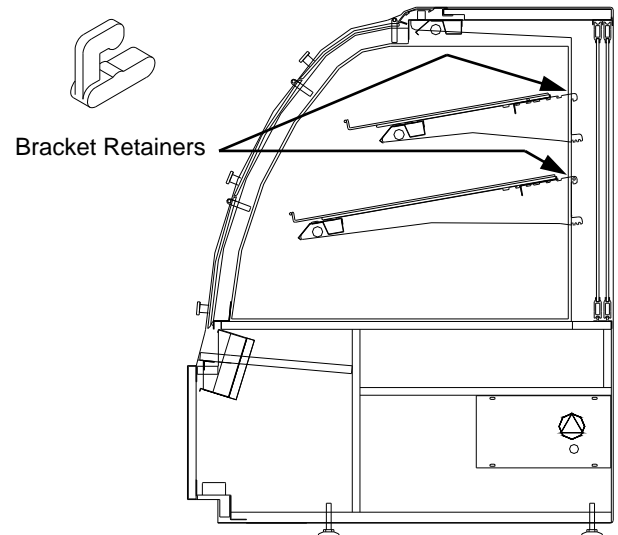
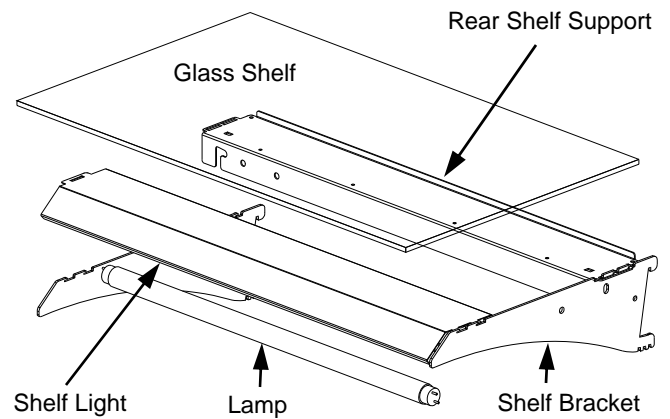

2. Hera® Style Light Fixtures

Removal of lamps:

- Remove Lamp Cover
- Grasp lamp firmly and carefully rotate 90° (until pins release from sockets).
- Pull outward and away from sockets.

Installation of lamps:

- Insert pins (at both ends of lamp) into sockets and slide into place.
- Holding lamp firmly, rotate 90° (until pins snap back into sockets)
- Return Lamp Cover.



3. Standard Fluorescent Style Light Fixtures

Removal of lamps:

- Grasp lamp firmly and carefully pull downward and out from socket.
- See photos at mid-right.

Installation of lamp:

- Align pins with slot.
- Insert pins into socket and push upward into place.
- See photos at mid-right.

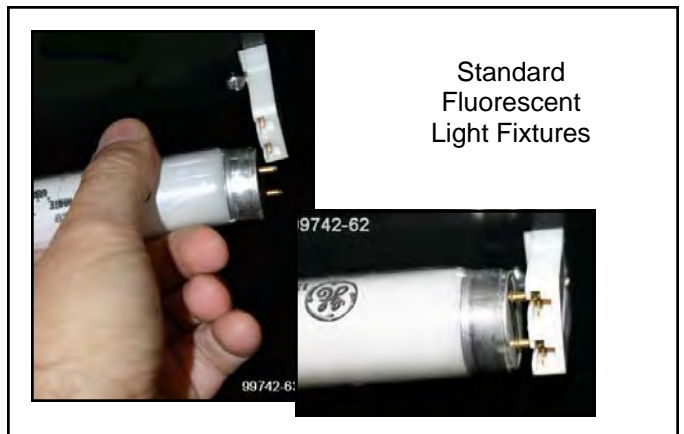

4. LED Style Light Fixtures

Removal of lamp:

- If case is provided with LED lights, they will rarely require change-out.
- Contact Structural Concepts' Technical Service Department for replacement parts (see the Technical Service section of operating manual).

Replacement of lamp:

- To replace LED Light Fixture, simply disconnect the existing LED light from its brackets and/or self-adhesive tape. Replace.
- **Note:** LED Light and Plug must be connected in a specific manner or they will not work.
- Make certain flat edge of plug connects to flat edge of LED light.
- See illustration at lower right.

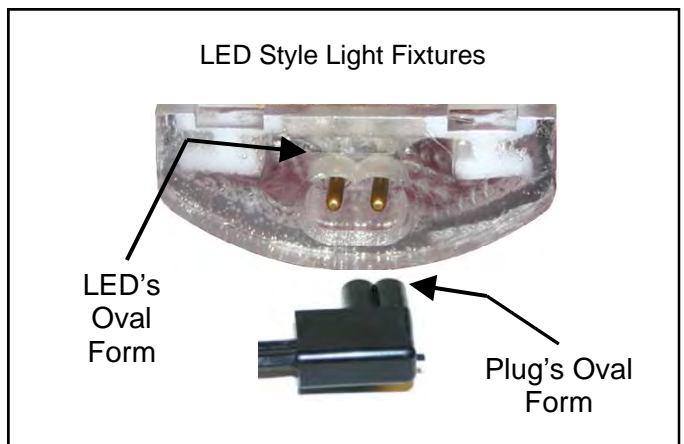
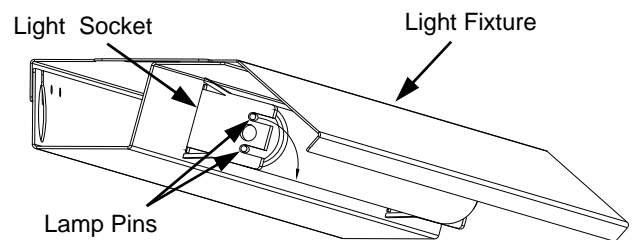

Serial Label Location & Information Listed / Technical Information & Service

- Serial labels are located near the electrical access on your case.
- Serial labels contain electrical information, as well as regulatory standards to which the case conforms.
- For additional technical information and service, see the *TECHNICAL SERVICE* page in this manual for instructions on contacting Structural Concepts' Technical Service Department.
- See sample serial label below.

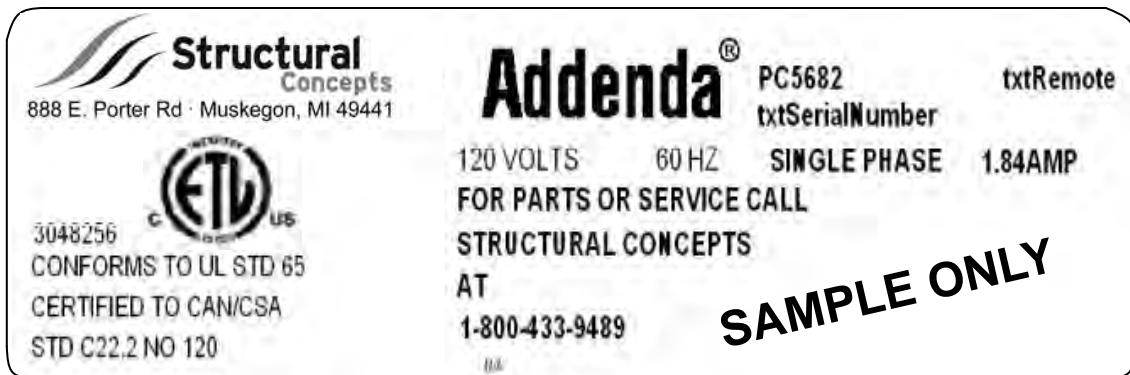

----- Sample Serial Label For Non-Refrigerated Case -----

TROUBLESHOOTING

Product is Drying Out	Check the relative humidity in the store.
Doors/Glass Won't Shut Properly	Check the case is aligned, level and plumb.
System is not Operating	Confirm the utility power is on.
	Check the MAIN power switch is on.
	Check the circuit breaker box for tripped circuits.
	If used, check the unit is properly plugged in.
Case Lights Not Working	Be sure ALL lights are plugged in or receptacles capped.
	Check bulb for proper installation and connection.
	Check for burned out bulb.
	Clean dirt and dust from the bulbs to prevent flickering.
	After performing all other checkpoints and lights are still not working Check for faulty ballast. Caution! This should be performed by a certified electrician only!

CLEANING SCHEDULE

Cleaning	Daily	Weekly	Monthly	Task
Clean Case Exterior	X			The acrylic must be cleaned with a mild soap and water solution and a soft cloth. Never use a household cleaner on acrylic.
	X			Clean sides and top of case with a warm soap and water solution.
Clean Case Interior	X			Clean glass shelves and mirrors with a household or commercial glass cleaner. The deck can be cleaned with a warm soap and water solution.
		X		Remove the deck and clean with soap and water.
		X		Remove rear doors and clean with a household or commercial cleaner (service cases only).
			X	Warning: lowering the front glass doors with items inside top cap can cause serious injury or damage to case. Raise the front curved glass doors. Clean inside the cavity at both ends of the hinged top cap with a mild soap and water solution.

STRUCTURAL CONCEPTS CORPORATION TECHNICAL SERVICE
PHONE NUMBER: 1.800.433.9489 or For Your Master Service Agent See
WWW.STRUCTURALCONCEPTS.COM/Contact/Master_Service_Agents.asp

WARRANTY INFORMATION

(Note: Standard Limited Warranty can be found at www.StructuralConcepts.com)

All sales by Structural Concepts Corporation (SCC) are subject to the following limited warranty. "Goods" refers to the product or products being sold by SCC.

Warranty Scope: Warranty is for equipment sold in the United States, Canada, Mexico and Puerto Rico. Equipment sold elsewhere may carry modified warranty.

Warranty; Remedies; Limitations. SCC warrants that if any Goods are found by an authorized representative of SCC not to be of good material or workmanship within one year of the date of shipments SCC will, at its option after inspection by an authorized representative, replace any defective Good or pay the reasonable cost of replacement for any such defective Goods, provided that written notice of the defect is given to SCC within 30 days of the appearance of such defect. If notice is not given within such period, any claim for breach of warranty shall be conclusively deemed to have been waived and SCC shall not be liable under this warranty. If SCC is unable to repair or replace the defective Goods, SCC shall issue a credit to the Purchaser for all or part of the purchase price, as SCC shall determine. The replacement or payment in the manner described above shall be the sole and exclusive remedy of Purchaser for a breach of this warranty. If any Goods are defective or fail to conform to this warranty, SCC will furnish instructions for their disposition. No Goods shall be returned to SCC without its prior consent.

SCC's liability for any defect in the Goods shall not exceed the purchase price of the Goods. SCC SHALL HAVE NO LIABILITY TO PURCHASE FOR CONSEQUENTIAL DAMAGES OF ANY KIND WHATSOEVER, INCLUDING, BUT NOT LIMITED TO, PERSONAL INJURY, PROPERTY DAMAGE, LOST PROFITS, OR OTHER ECONOMIC INJURY DUE TO ANY DEFECT IN THE GOODS OR ANY BREACH OF SCC, SCC SHALL NOT BE LIABLE TO THE PURCHASER IN TORT FOR ANY NEGLIGENT DESIGN OR MANUFACTURE OF THE GOODS, OR FOR THE OMISSION OF ANY WARNING THEREFROM.

SCC shall have no obligation or liability under this warranty for claims arising from any other party's (including Purchaser's) negligence or misuse of the Goods or environmental conditions. This warranty does not apply to any claim or damage arising for or caused by improper storage, handling, installation, maintenance, or from fire, flood, accidents, structural defects, building settlement or movement, acts of God, or other causes beyond SCC's control.

Except as expressly stated herein, SCC makes no warranty, express, implied, statutory or otherwise as to any parts or goods not manufactured by SCC. SCC shall warrant such parts or Goods only (I) against such defects, (II) for such periods of time, and (III) with such remedies, as are expressly warranted by the manufacturer of such parts of Goods. Notwithstanding the foregoing, any warranty with respect to such parts of Goods and any remedies available as a result of a breach thereof shall be subject to all of the procedures, limitations, and exclusions set forth herein.

THE WARRANTIES HEREIN ARE IN LIEU OF ALL WARRANTIES, EXPRESS, IMPLIED, STATUTORY, OR OTHERWISE. IN PARTICULAR, SCC MAKES NO WARRANTY OF MERCHANTABILITY OR FITNESS FOR A PARTICULAR PURPOSE.

No representative, agent or dealer of SCC has authority to modify, expand, or extend this Warranty, to waive any of the limitations or exclusions, or to make any different or additional warranties with respect to Goods.

Period of Limitations. No claim, suit or other proceeding may be brought by Purchaser for any breach of the foregoing warranty or this Agreement by SCC or in any way arising out of this Agreement or relating to the Goods after one year from the date of the breach. In the interpretation of this limitation on action for a breach by SCC, it is expressly agreed that there are no warranties of future performance of the goods that would extend that period of limitation herein contained for bringing an action.

Indemnifications. Purchaser agrees to indemnify, hold harmless, and defend SCC if so requested, from any and all liabilities, as defined herein, suffered, or incurred by SCC as a result of, or in connection with, any act, omission, or use of the Goods by Purchaser, its employees or customers, or any breach of this Agreement by Purchaser. Liabilities shall include all costs, claims, damages, judgments, and expenses (including reasonable attorney fees and costs).

Remedies of SCC. SCC's rights and remedies shall be cumulative and may be exercised from time to time. In a proceeding or action relating to the breach of this Agreement by Purchaser, Purchaser shall reimburse SCC for reasonable costs and attorney's fees incurred by SCC. No waiver by SCC of any breach of Purchaser shall be effective unless in writing nor operate as a waiver of any other breach of the same term thereafter. SCC shall not lose any right because it has not exercised it in the past.

Applicable Law. This Agreement is made in Michigan and shall be governed by and interpreted according to Michigan law. Any lawsuit arising out of this Agreement or the Goods may be handled by a federal or state court whose district includes Muskegon County, Michigan, and Purchaser consents that such court shall have personal jurisdiction over Purchaser.

Miscellaneous. If any provision of this Agreement is found to be invalid or unenforceable under any law, the provision shall be ineffective to that extent and for the duration of the illegality, but the remaining provisions shall be unaffected. Purchaser shall not assign any of its rights nor delegate any of its obligations under this Agreement without prior written consent of SCC. This Agreement shall be binding upon and inure to the benefit of SCC and Purchaser and each of their legal representatives, successors and assigns.

SCC warrants its products to be free of defects in materials and workmanship under normal use and service for a period of one (1) year from the date of delivery.

This warranty is extended only to the original purchaser for use of the Goods. It does not cover normal wear parts such as plastic tongs, tong holders, tong cables, bag holders, or acrylic dividers.

General Conditions. All service labor and/or parts charges are subject to approval by SCC. Contact the Customer Service Department in writing or call 231-798-8888.

All claims must contain the following information: (1) model & serial code number of equipment; (2) the date and place of installation; (3) the name and address of the agency which performed the installation; (4) the date of the equipment failure; and (5) a complete description of the equipment failure and all circumstances relating to that failure.

Once the claim has been determined to be a true warranty claim by SCC's Customer Service Department, the following procedure will be taken: (1) replacement parts will be sent at no charge from SCC on a freight prepaid basis; (2) reimbursement for service labor will be paid if the following conditions have been met - (a) prior approval of service agency was awarded from the Customer Service Department; and (b) an itemized statement of all labor charges incurred is received by the Customer Service Department. The cost of the service labor reimbursement will be based on straight time rates and reasonable time for the repair of the defect.

If problems occur with any compressor, notify SCC's Customer Service Department immediately. Any attempt to repair or alter the unit without prior consent from the Customer Service Department will render any warranty claim null and void. This warranty and protection plan does not apply to any condensing unit or any part thereof which has been subject to accident, negligence, misuse, or abuse, or which has not been operated in accordance with the manufacturer's recommendations or if the serial number of the unit has been altered, defaced, or removed.

Limit of Liability. The limit of liability of SCC toward the exchange cost of the original condensing unit, F.O.B. SCC, Norton Shores, MI, of each motor-compressor assembly replaced during the warranty shall not exceed manufacturer's current established wholesaler's exchange price and in no case shall the labor of removing or replacing the motor-compressor or parts thereof be the responsibility of SCC.