

# Harmony™

## INSTALLATION AND OPERATING MANUAL

PN 54171

### 33" DEEP SELF-SERVICE REFRIGERATED BAKERY MERCHANDISER

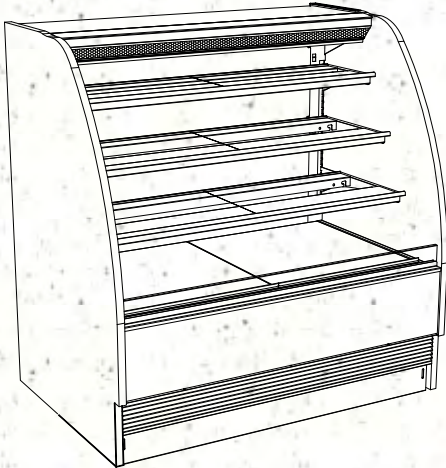

HMO5153R

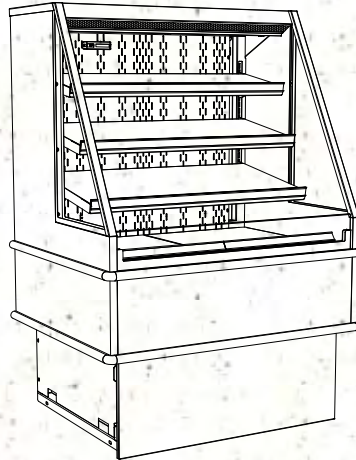

HMO3953R.5749

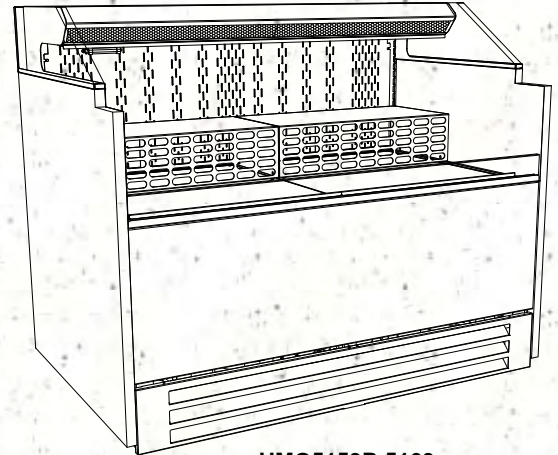

HMO5153R.5163  
(Shown With Risers)

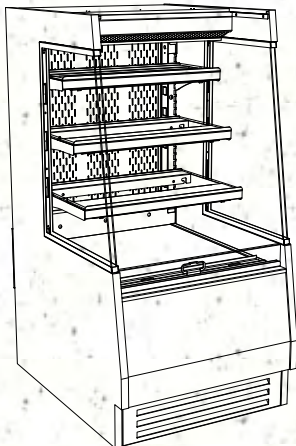

HMO2653R.5194

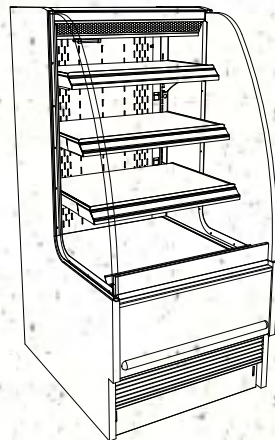

HMO2653R

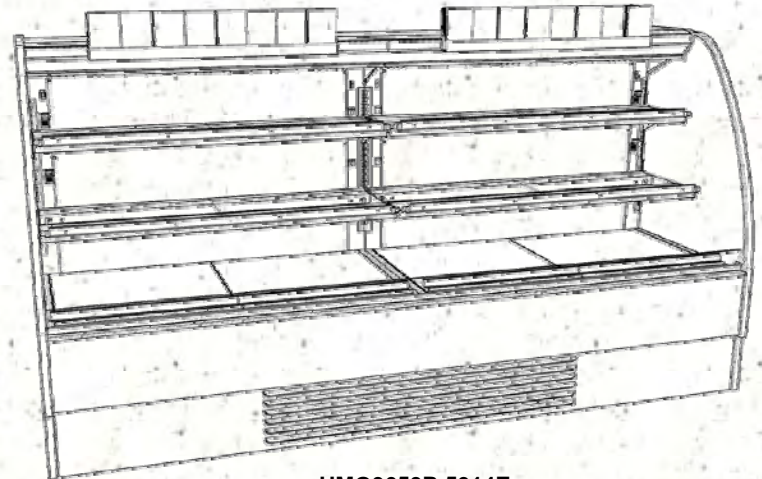

HMO9653R.5914E  
(Shown With Optional Recipe  
Card Holders)

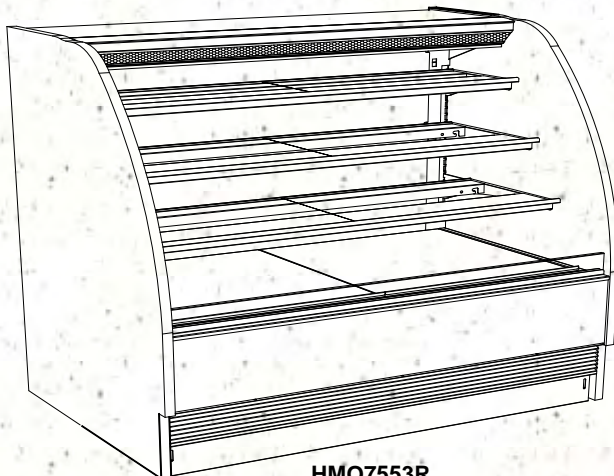

HMO7553R

- >>> Model HMO2653R (26 7/8" L\* x 34 3/4" D x 52 3/4" H\*\*)
- >>> Model HMO2653R.5194 (26 7/8" L\* x 34 3/4" D x 52 3/4" H\*\*)
- >>> Model HMO3953R (38 7/8" L\* x 32 1/8" D x 52 3/4" H\*\*)
- >>> Model HMO3953R.5749 (38 7/8" L\* x 32 1/8" D x 58 3/8" H\*\*)
- >>> Model HMO5153R (50 7/8" L\* x 32 1/8" D x 52 3/4" H\*\*)
- >>> Model HMO5153R.5163 (50 7/8" L\* x 32 1/8" D x 41 3/4" H\*\*)
- >>> Model HMO6353R (62 11/16" L\* x 32 1/8" D x 52 5/8" H\*\*)
- >>> Model HMO7553R (75 1/4" L\* x 32 1/8" D x 52 5/8" H\*\*)
- >>> Model HMO9653R.5914E (99 1/2" L\* x 34 1/8" D x 52 5/8" H\*\*)

\*Includes 1" End Panels

\*\*Includes Levelers at 1 1/4" Below Base Frame

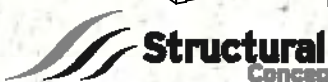

888 E. Porter Road · Muskegon, MI 49441 Phone: 231.798.8888 Fax: 231.798.4960 www.structuralconcepts.com

## TABLE OF CONTENTS

SHIPMENT CONDITION / DAMAGE DISCOVERED AT DELIVERY or UNCRATING / SHORTAGES	3
OVERVIEW / TYPE / COMPLIANCE / WARNINGS / PRECAUTIONS / WIRING / PLUGS .....	4-5
CASE REMOVAL FROM SKID (LEVELERS OR CASTERS) .....	6
INSTALLATION - CAULKING AND BOLTING UNITS TOGETHER .....	7
INSTALLATION, CONT'D - MODEL HMO3953R.5749 ONLY: LINE-UP WITH MODEL DP812R.5748	8
INSTALLATION, CONT'D - MODEL HMO3953R.5749 ONLY: GENERAL LAYOUT .....	9
INSTALLATION, CONT'D - MODEL HMO3953R.5749 ONLY: DRAIN & CONDENSATE PACKAGE ..	10
INSTALLATION, CONT'D - CONNECTIONS/CONTROLLER/LOCK/MAIN POWER SWITCH .....	11
INSTALLATION, CONT'D - ELECTRICAL CONNECTIONS / EVAPORATOR FAN AREA .....	12
DRAIN, HOSE AND BRACKET PLACEMENT ILLUSTRATIONS .....	13
POSITIONING & ALIGNING CASE / ADJUSTING LEVELERS / FRAME SUPPORT RAILS .....	14
ADJUSTING TOE-KICK / REMOVING FRONT GRILLE .....	15
REAR FILTER / GRILLE / PANEL ACCESS / COMPRESSOR PAN SHIPMENT SCREWS .....	16
START-UP AND OPERATION .....	17
START-UP AND OPERATION, CONTINUED: NIGHT AIR CURTAIN OPERATING INSTRUCTIONS	18
SOLID REAR DOOR (MODEL HMO2653R.5194) .....	19
REAR DOOR WITH PERFORATED PLEXIGLAS® PLENUM (MODEL HMO2653R) .....	20
REAR SLIDING DOOR W/ADJOINED PERFORATED PLEXI® PLENUM (MODEL HMO3953R) .....	21
SECURITY GRID INFORMATION .....	22-23
NIGHT AIR CURTAIN (OPTIONAL) OPERATING INSTRUCTIONS .....	24
MAINTENANCE FUNDAMENTALS - SHELF ASSEMBLY REMOVAL / FLUORESCENT LIGHTS .....	25
MAINTENANCE FUNDAMENTALS, CONTINUED - LED LIGHT FIXTURES .....	26
MAINTENANCE: REFRIGERATION PACKAGE ILLUSTRATION (MODEL HMO2653R.5194) .....	27
GENERAL CLEANING (TO BE PERFORMED BY STORE PERSONNEL) .....	28
CLEANING SCHEDULE - STAINLESS STEEL (TO BE PERFORMED BY STORE PERSONNEL) ....	29
TROUBLESHOOTING (TO BE PERFORMED BY TRAINED SERVICE PROVIDERS ONLY) .....	30
GENERAL CLEANING (TO BE PERFORMED BY TRAINED SERVICE PROVIDERS ONLY) .....	31
TROUBLESHOOTING (TO BE PERFORMED BY TRAINED SERVICE PROVIDERS ONLY) .....	32-34
TROUBLESHOOTING - CONDENSING SYSTEM (TO BE PERFORMED BY TRAINED SERVICE PROVIDERS ONLY) .....	35
TROUBLESHOOTING - EVAPORATOR SYSTEM (TO BE PERFORMED BY TRAINED SERVICE PROVIDERS ONLY) .....	36
PREVENTIVE MAINTENANCE (TO BE PERFORMED BY TRAINED SERVICE PROVIDERS ONLY)	37
PREVENTIVE MAINTENANCE OF HONEYCOMB AIR DIFFUSERS (TO BE PERFORMED BY TRAINED SERVICE PROVIDERS ONLY) .....	38
SERIAL LABEL INFORMATION & LOCATION .....	39
CAREL® CONTROLLER - PROGRAMMING THE INSTRUMENT .....	40
CAREL® CONTROLLER - USER INTERFACE, SUMMARY TABLES OF ALARMS & SIGNALS .....	41
CAREL® CONTROLLER - Summary Table of Operating Parameters (After Programming Key) .....	42
TECHNICAL SERVICE CONTACT INFORMATION & WARRANTY INFORMATION .....	43

### **1. Shipment Condition**

- Before and during unloading, check all equipment for damage.

### **2. Damage Discovered During Delivery**

- 3rd Party Carrier: Describe damage on freight bill and obtain signature of driver. Carrier will supply necessary claim forms. If these steps are not taken, carrier may refuse your claim.
- Prepaid and Add: Contact carrier (and follow same procedure as with 3rd party carrier). Also contact Structural Concepts at 1-800-433-9489.

### **3. Risk of Damage When Case is NOT Uncrated at Installation Site**

- Uncrating equipment at a facility OTHER THAN the installation site may result in SEVERE DAMAGE to unit when transporting to final destination.
- Structural Concepts strongly recommends that equipment ONLY be uncrated at installation site.

### **4. Damage Discovered After Uncrating**

- 3rd Party Carrier: Contact carrier within 10 days of delivery for their procedures; retain all packaging. If these steps are not taken, carrier may refuse your claim.
- Prepaid and Add: Contact carrier (and follow same procedure as with 3rd party carrier). Also contact Structural Concepts at 1-800-433-9489 within 10 days of delivery.

### **5. Shortages**

- If a shortage exists (and it is the responsibility of Structural Concepts) call 1-800-433-9489. Structural Concepts will acknowledge shortages within 10 days from receipt of equipment.
- If a shortage involves the carrier, notify carrier immediately and request an inspection.

**OVERVIEW**

- These Structural Concepts Harmony® self-service cases are designed to merchandise packaged products at 41 °F (5 °C) or less product temperatures (unless custom cases with wire rack shelving).
- Cases should be installed and operated according to this operating manual's instructions to ensure proper performance.
- Improper use will void warranty.

**TYPE 1 vs. TYPE 2 CONDITIONS**

This unit is designed for the display of products in ambient store conditions where temperatures and humidity are maintained within a specific range.

- For Type 1 Conditions (most cases): ambient conditions are to be at 55% maximum humidity and maximum temperatures of 75 °F (24 °C).
- For Type 2 Conditions: ambient conditions are to be at 60% maximum humidity and maximum temperatures of 80 °F (27 °C).

- If unsure if unit is designed for Type 1 or 2, see tag next to serial label. See **SERIAL LABEL LOCATION & INFORMATION LISTED / TECH INFO & SERVICE** section in this manual for sample serial labels.

**COMPLIANCE**

- Performance issues when in violation of applicable NEC, federal, state and local electrical and plumbing codes are not covered by warranty.
- See below compliance guideline.

**WARNINGS**

- This page contains important warnings to prevent injury or death.
- Please read carefully!

**PRECAUTIONS and WIRING DIAGRAMS**

- See next page for **PRECAUTIONS** and **WIRING DIAGRAM** information.



**ATTENTION  
INSTALLER**

**COMPLIANCE**  
This equipment **MUST** be installed in compliance with all applicable NEC, federal, state and local electrical and plumbing codes.



**WARNING**  
Risk of electric shock. Disconnect power before servicing unit. **CAUTION!** More than one source of electrical supply is employed with units that have separate circuits. **Disconnect ALL ELECTRICAL SOURCES before servicing.**



**WARNING**  
Hazardous moving parts. Do not operate unit with covers removed. Fan blades may be exposed when deck panel is removed. **Disconnect power before removing deck panel.**



**WARNING**  
Electric coil condensate pans are hot! **Disconnect and allow to cool before cleaning or removing from case.**

**PRECAUTIONS**

- Following are important precautions to prevent damage to unit or merchandise.
- Please read carefully!
- See previous page for specifics on **OVERVIEW**, **CONDITION TYPE**, **COMPLIANCE** and **WARNINGS**.

**WIRING DIAGRAM**

- Each case has its own wiring diagram folded and in its own packet.
- Wiring diagram placement may vary; it may be placed near ballast box, field wiring box, raceway cover, or other related location.

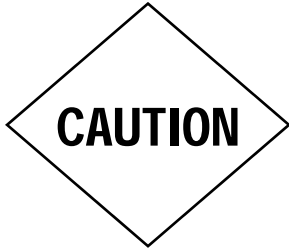

**CAUTION! LAMP REPLACEMENT GUIDELINES**  
 LED lamps reflect specific size, shape and overall design. Any replacements must meet factory specifications.  
 Fluorescent lamps have been treated to resist breakage and must be replaced with similarly treated lamps.



**CAUTION! GFCI BREAKER USE RECOMMENDATION**  
 If N.E.C. (National Electric Code) or your local code requires GFCI (Ground Fault Circuit Interrupter) protection, the use of a GFCI breaker is strongly recommended.



**CAUTION! POWER CORD AND PLUG MAINTENANCE**  
 Risk of electric shock. If cord or plug becomes damaged, replace only with cord and plug of same type.



**CAUTION! ADVERSE CONDITIONS / SPACING ISSUES**

- Performance issues caused by adverse conditions are NOT warranted.
- Unit must be kept at least 15-feet from exterior doors, overhead HVAC vents or any air curtain disruption to maintain proper temperatures.
- Unit must not be exposed to direct sunlight or any heat source (ovens, fryers, etc.).
- Keep at least 8-inch clearance above unit for air discharge (self-contained units only).

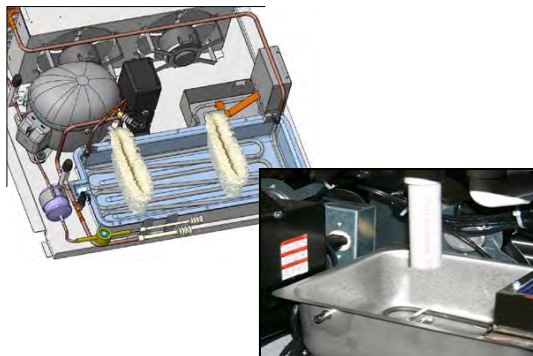

**CAUTION! CHECK CONDENSATE PAN POSITION & PLUG**  
 Water on flooring can cause extensive damage!  
 Before powering up unit, check the following:

- Condensate pan **MUST BE** positioned directly under condensate drain.
- Condensate pan plug **MUST BE** securely plugged into receptacle.
- Check that overflow pan is fully functional.
- If wicking material is used, check that it is secure.

## CASE REMOVAL FROM SKID (LEVELERS OR CASTERS)

### **1. Removing Case Shipping Brackets That Are Attached To Skid**

- Remove screws holding Case Shipping Brackets to skid.
- Remove Case Shipping Brackets from Skid.
- See illustrations below. **Note:** Shipping Brackets will vary in size, shape, material and location depending upon case type and model.

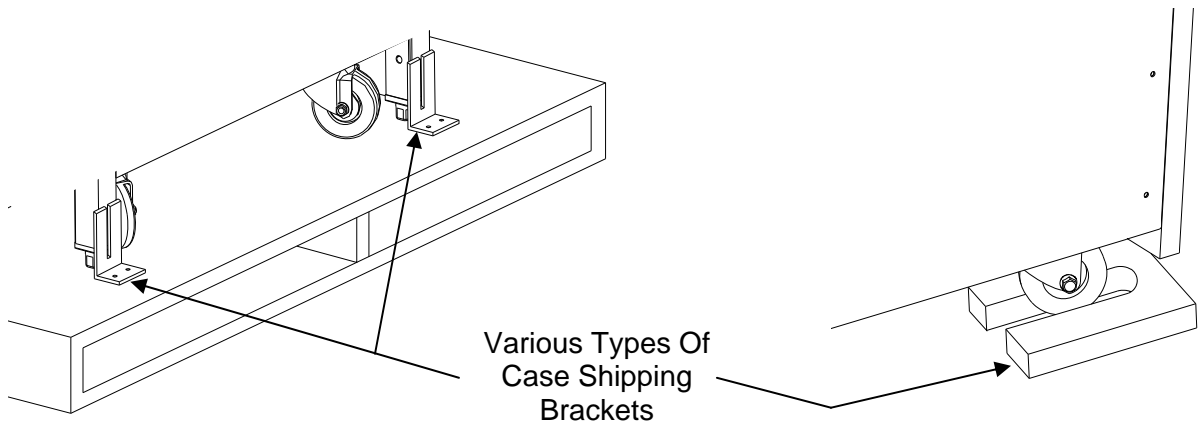

### **2. Remove Case (With Levelers) From Skid**

- To prevent damage, support case while sliding it toward edge of skid.
- When case is at edge of skid, carefully lower to floor (so two levelers rest on floor).
- Carefully slide skid out from under case.
- After removal of case from skid, place into position.
- **Note:** Illustration below reflects general outline of sample case and does not reflect any particular model or options).

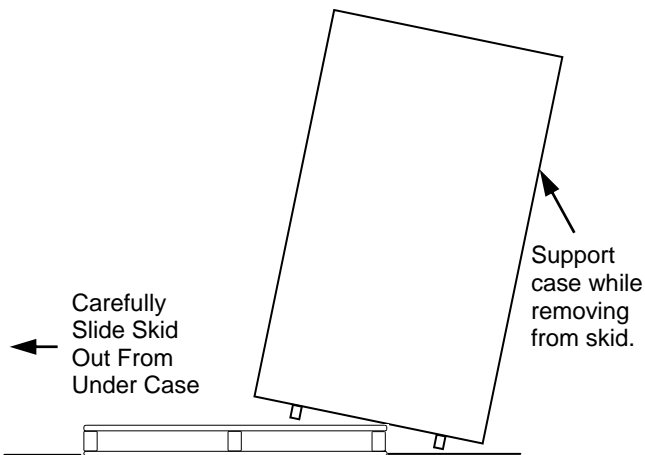

### **3. Remove Case (With Casters) From Skid**

- A. Place ramp up against skid (to allow case to smoothly slide off from skid).
  - B. Maintain support of case at all times or center of gravity may cause case to fall.
  - C. Unlock Casters. Slide unit to rear of skid. Slide down ramp and off from skid.
- **Note:** Illustrations reflect general outline of sample case and may not reflect your particular model or options).

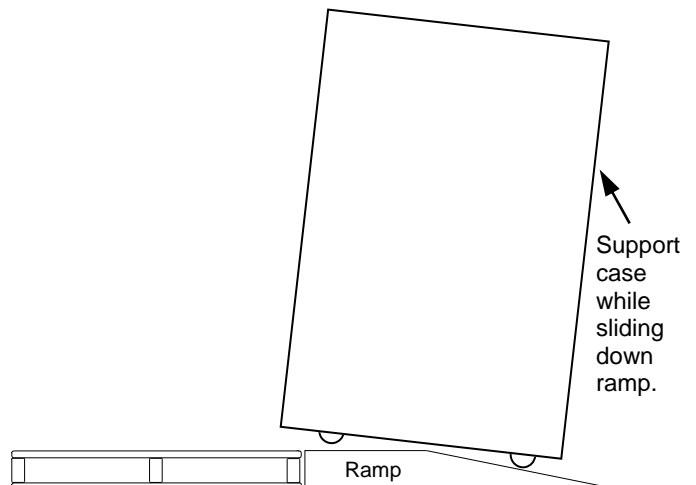

## INSTALLATION - CAULKING AND BOLTING UNITS TOGETHER

### Installation

**Note:** Units shown may not depict an exact representation of your particular unit being installed.

#### 1. Position and Level Units

- Position Units. Align multiple units carefully in areas A, B, and C.
- See illustration at right.

#### 2. Ventilation and Clearance

- **Self-Contained** refrigerated cases must maintain airflow clearance of 6" (minimum) to 12" (recommended) at front and rear.
- Restriction of air can void warranty.
- Illustration at top-right may not reflect every feature or option of your particular case.

#### 3. Caulking and Bolting Units Together

Follow these steps to assure a secure, level lineup.

- Begin all lineups leveling from highest point of floor.
- After the 'first' case is level, apply industrial grade butyl caulk on non-visible areas (at case end). Use industrial grade silicone sealant on visible areas (at case end).
- Form Two (2) Caulk/Sealant Lines:** (Sanitation and Refrigeration). See illustration at below-right for outline of caulk/sealant lines.
- Line up 'second' case bolt-hole to bolt-hole to 'first' case.
- Using SCC-supplied bolts (found in installation packet), insert bolts in bolt hole locations (shown at right). You may need to remove decking to access lower bolt holes.
- Caution! Front of cases **MUST** be flush with each other! Also, after leveling, all cases to be at same height.
- Using SCC-supplied nuts & bolts, **lightly tighten** each of the 5 to 8 bolts in a cross-wise pattern. Work your way around the pattern, tightening more firmly at each pass. **Do not** firmly tighten one bolt and then start on the next!
- After the cases are bolted together, level the 'second' case. Repeat this process for each case to be adjoined.
- After all lined-up cases are level, seal all seams with industrial grade silicone sealant.

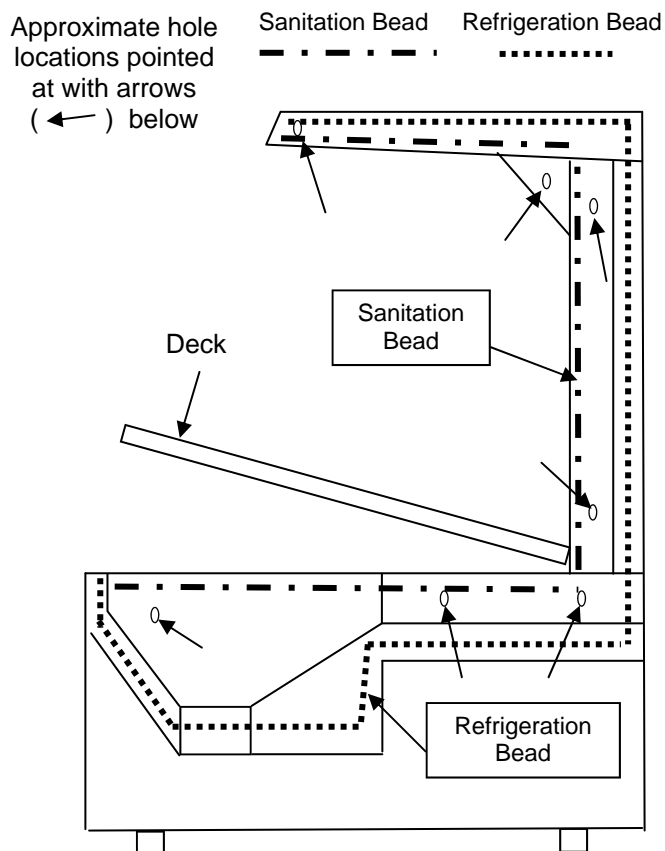
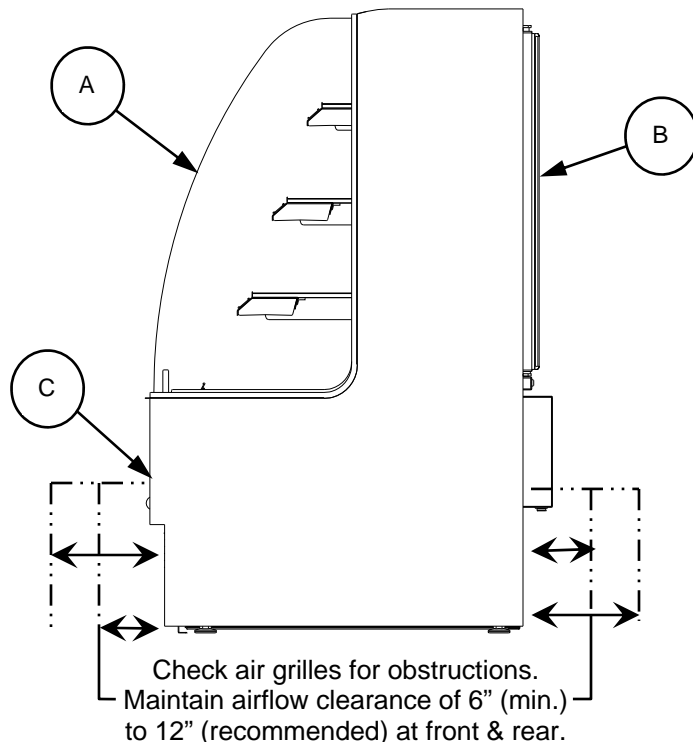

**4. Line-Up With Model DP812R.5748**

- Illustration below shows adjointment of model HMO3953R.5749 with separate model DP812R.5748.
- Model DP812R.5748 has its own operating manual, SCC P/N 20-32217.

- *Note: Depending upon features and options chosen, illustration below may not reflect every aspect of your particular models.*

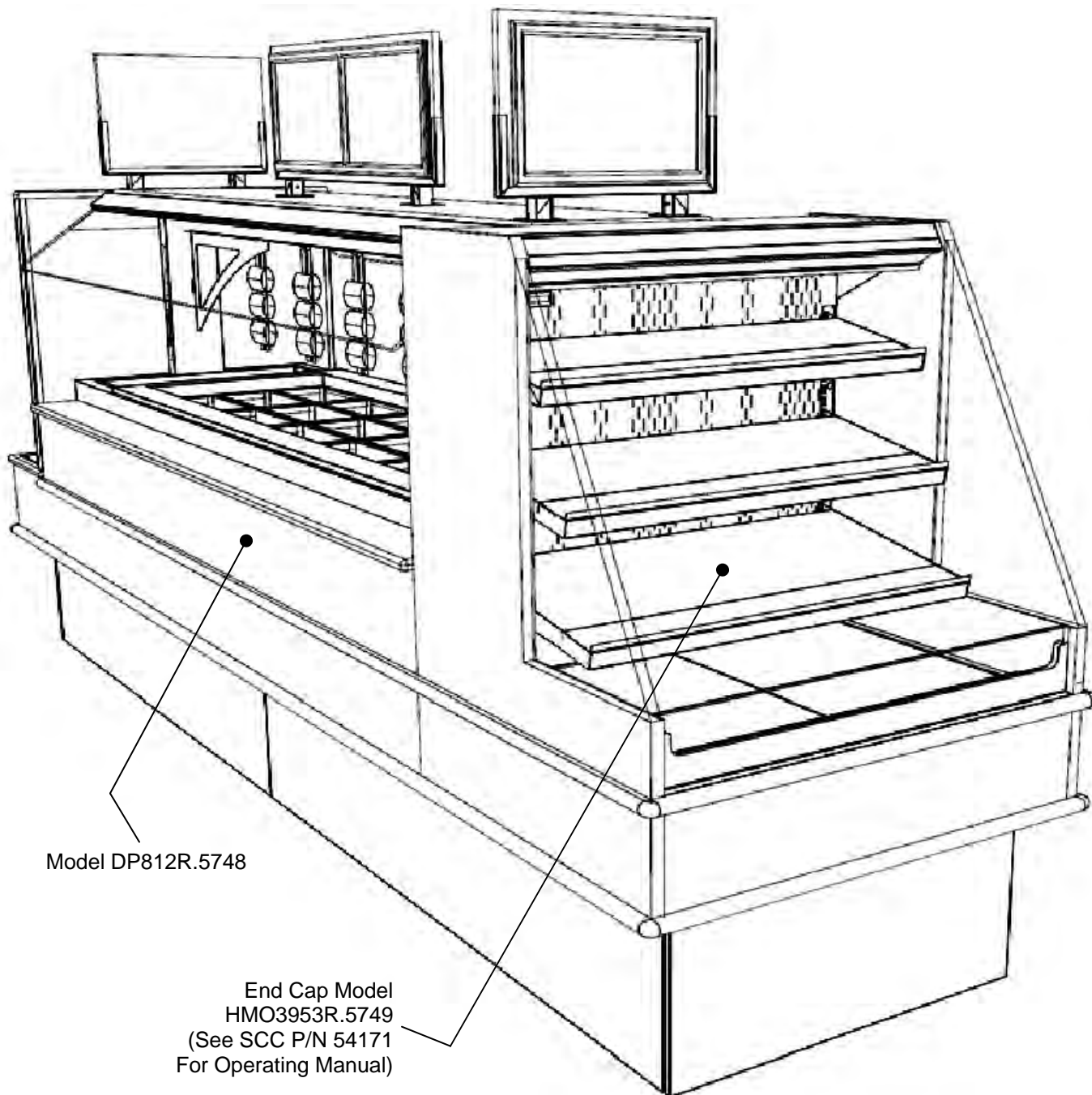

**5. Model HMO3953R.5749 General Layout**

- Illustration below shows the general layout of model HMO3953R.5749.
- Case wiring source is from its adjoining case (SCC P/N DP812R.5748).

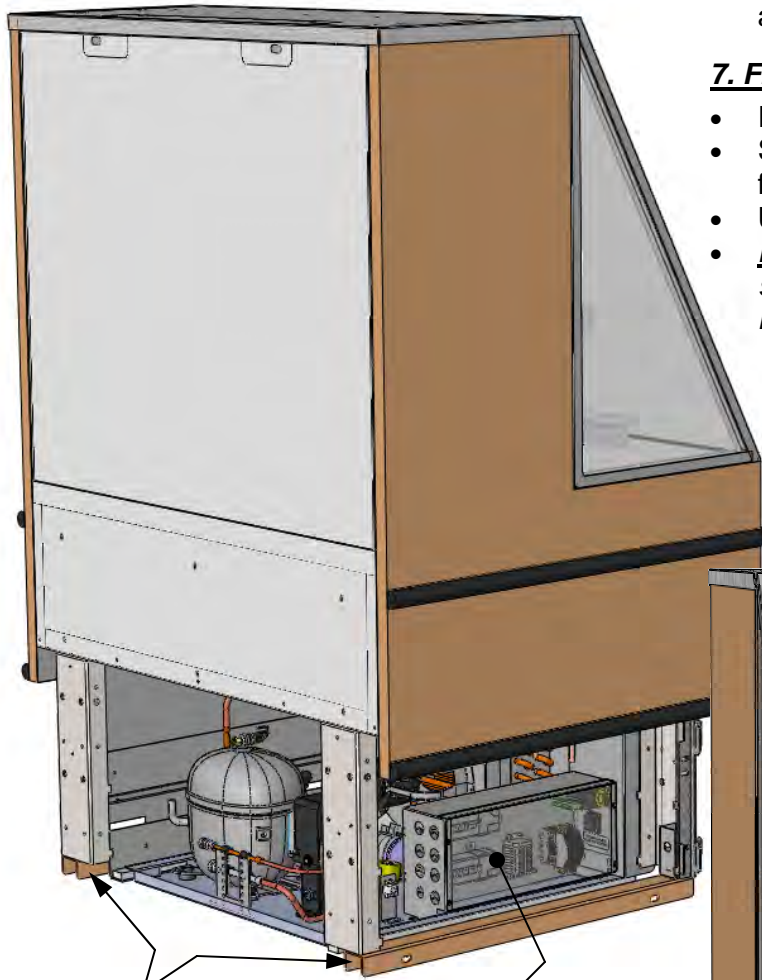

Frame Support Rails

View of Electrical Box, LED Drivers, Contactor, Terminal Block, Temperature Controller, Main Power Switch, Etc.

**6. Position & Align Case Alongside Other Cases**

- Before adjusting levelers (or shimming frame support rails), make certain that the case is in proper position and, if required, aligned with adjoining case(s).
- This may require the repositioning of the case you are installing or the already positioned case(s).

**7. Frame Support Rails Must Be Shimmed**

- Illustration below shows frame support rails.
- Shims will be provided with all cases that have frame support rails.
- Use shims to level case.
- **Note:** After case is in position, it must be sealed to floor to prevent entry or leakage of liquid or moisture.

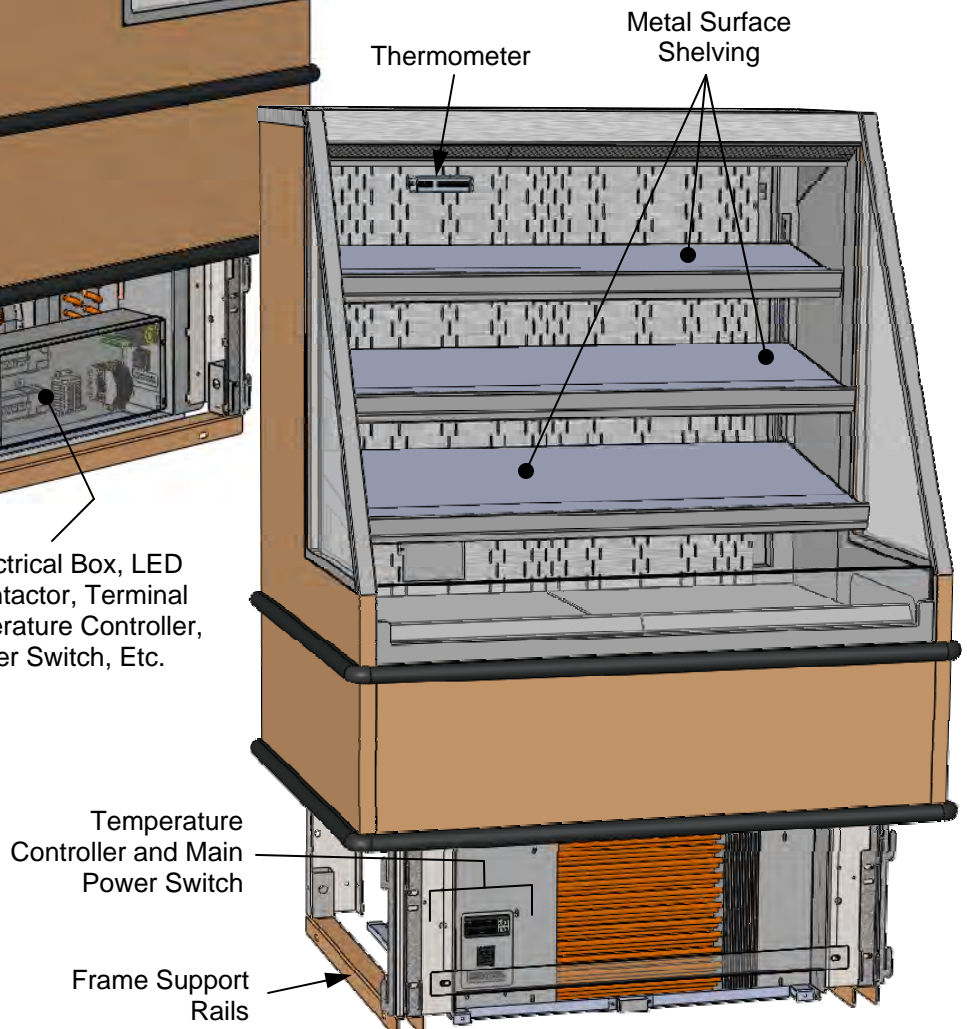

Thermometer

Metal Surface Shelving

Temperature Controller and Main Power Switch

Frame Support Rails

**8. Model HMO3953R.5749 Drain and Condensate Package**

- Illustration at right shows the location of model HMO3953R.5749 drain.
- Drain from case must be routed to floor drain.
- Illustration below shows the general layout of model HMO3953R.5749 condensate package.
- Case wiring source is from its adjoining case (SCC P/N DP812R.5748).
- *Note: Depending upon features and options chosen, illustration below may not reflect every aspect of your particular models.*

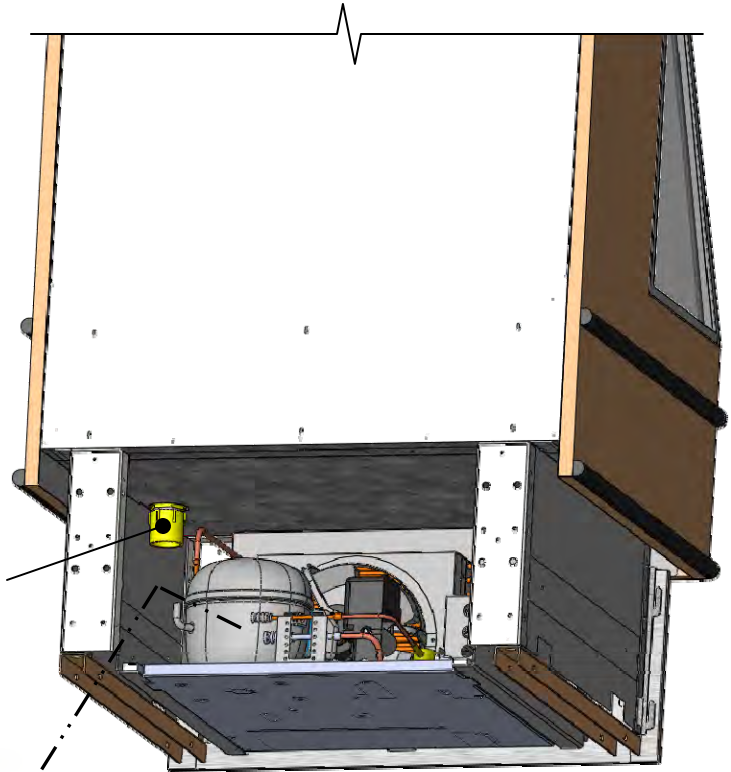

Drain (From Evaporator Package)  
To Be Routed To Floor Drain

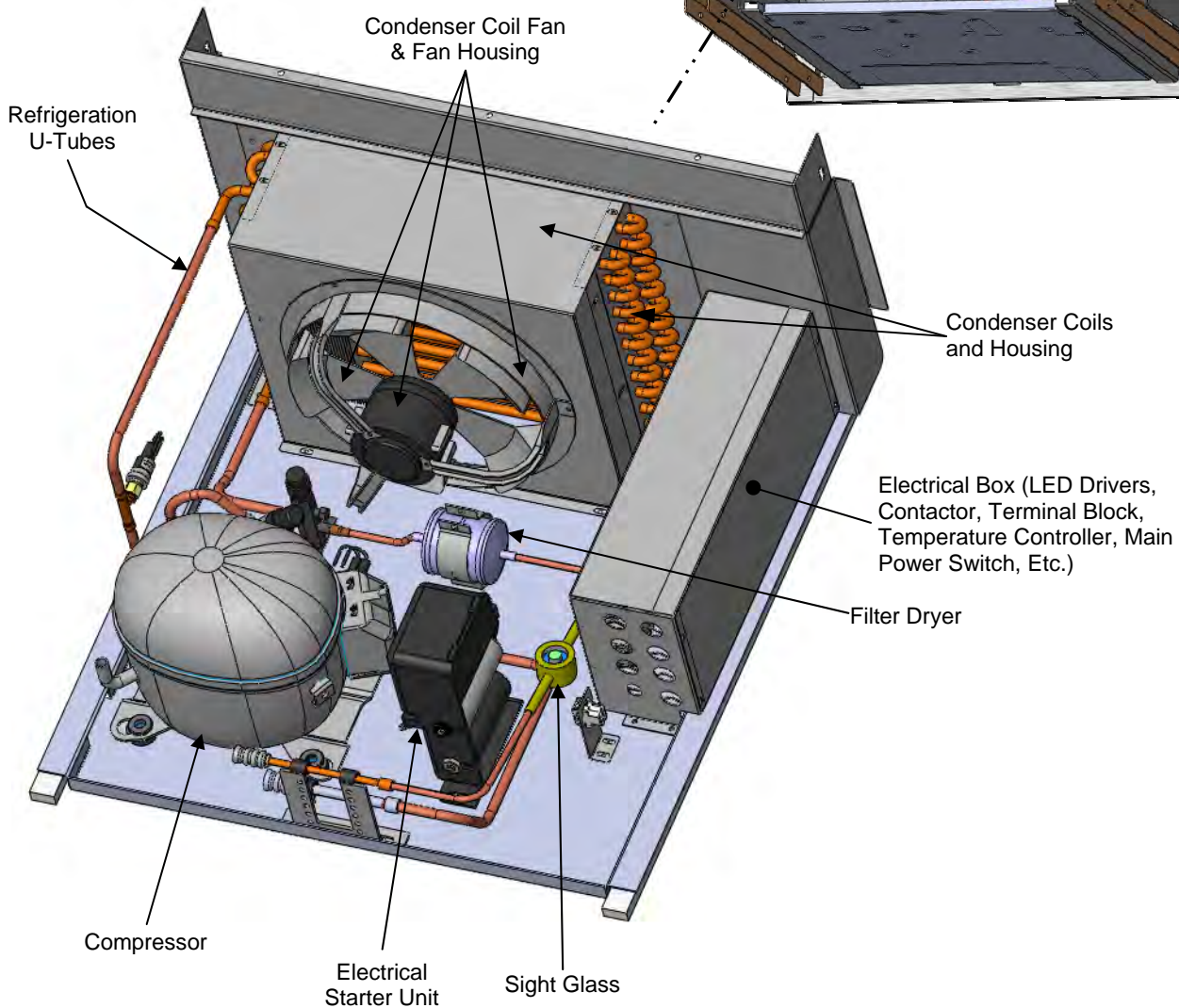

**9. Connections/Controller/Lock/Main Power Switch (Self-Contained Units)**

Controller/Ballast box location is at customer rear.

- See illustration at left.
- Below illustrations show layout of controller, ballasts, main power switch, door lock, terminal block, etc. after removal of controller/ballast box.

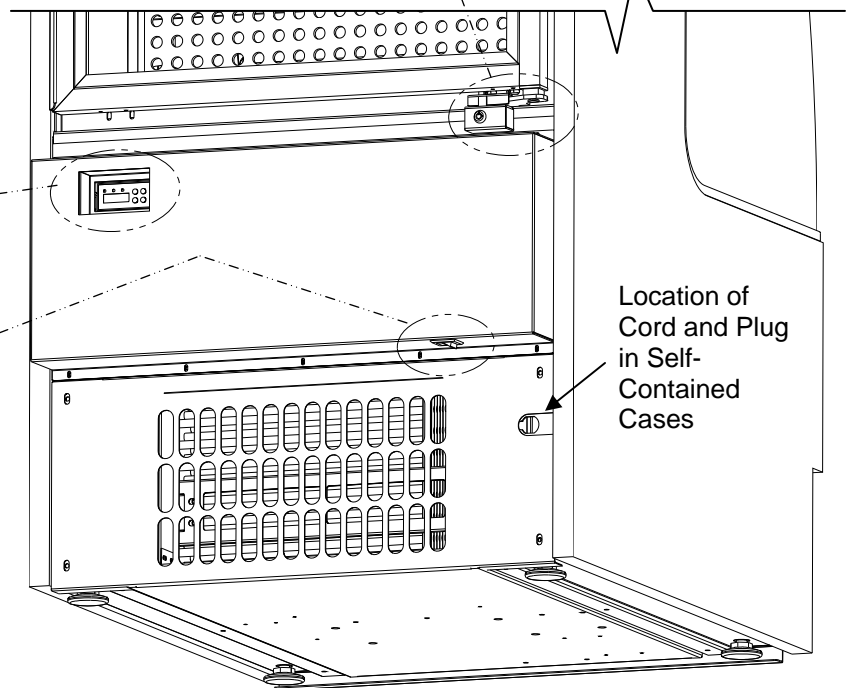
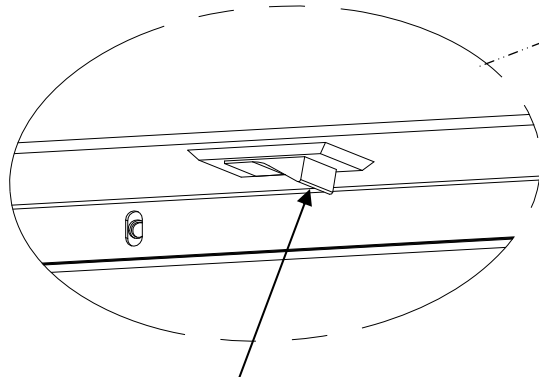
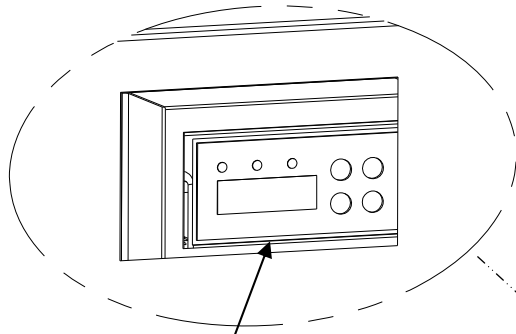
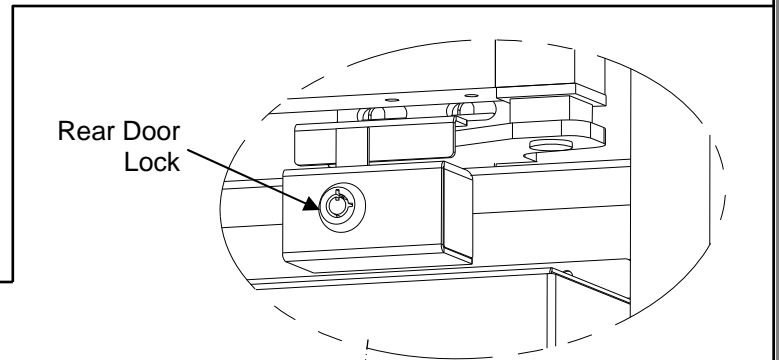
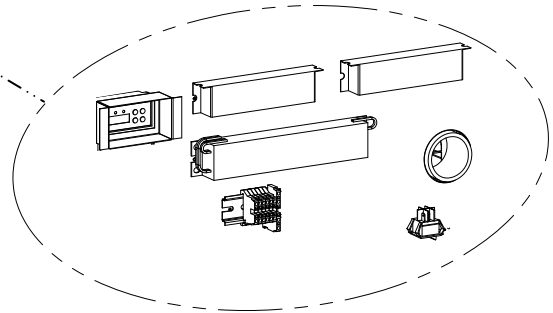
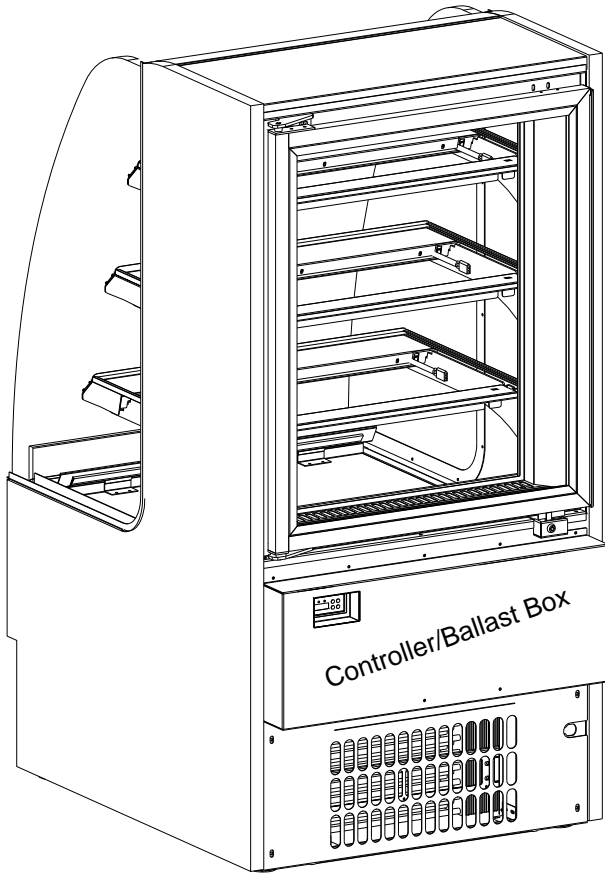

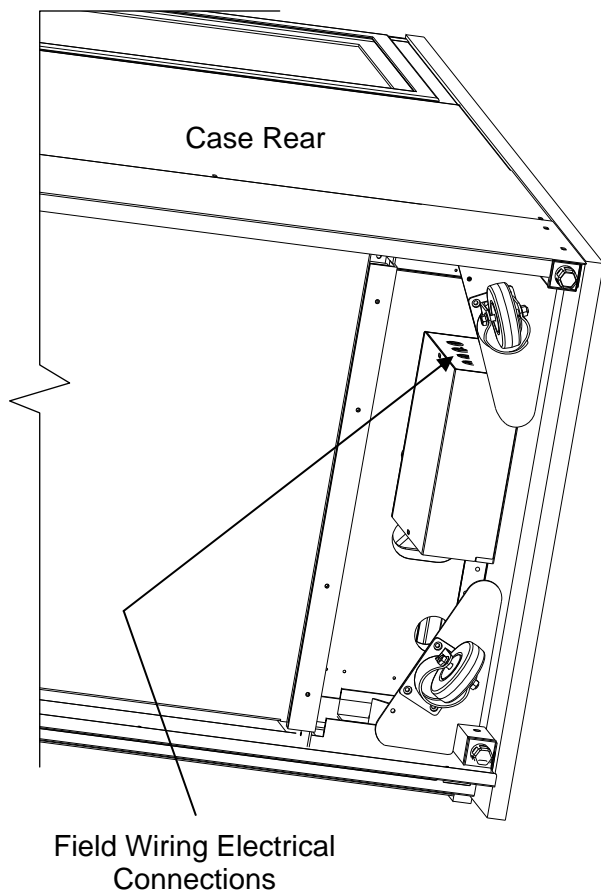

**10. Electrical Connections (Certain Remote Cases)**

Field wiring connection / electrical access location is at customer-left side of case.

- Single phase leads are provided.

**11. Evaporator Fan Area**

- Illustration below shows front of case with decking removed.
- See Preventive Maintenance section in this manual for guidelines on cleaning this area.

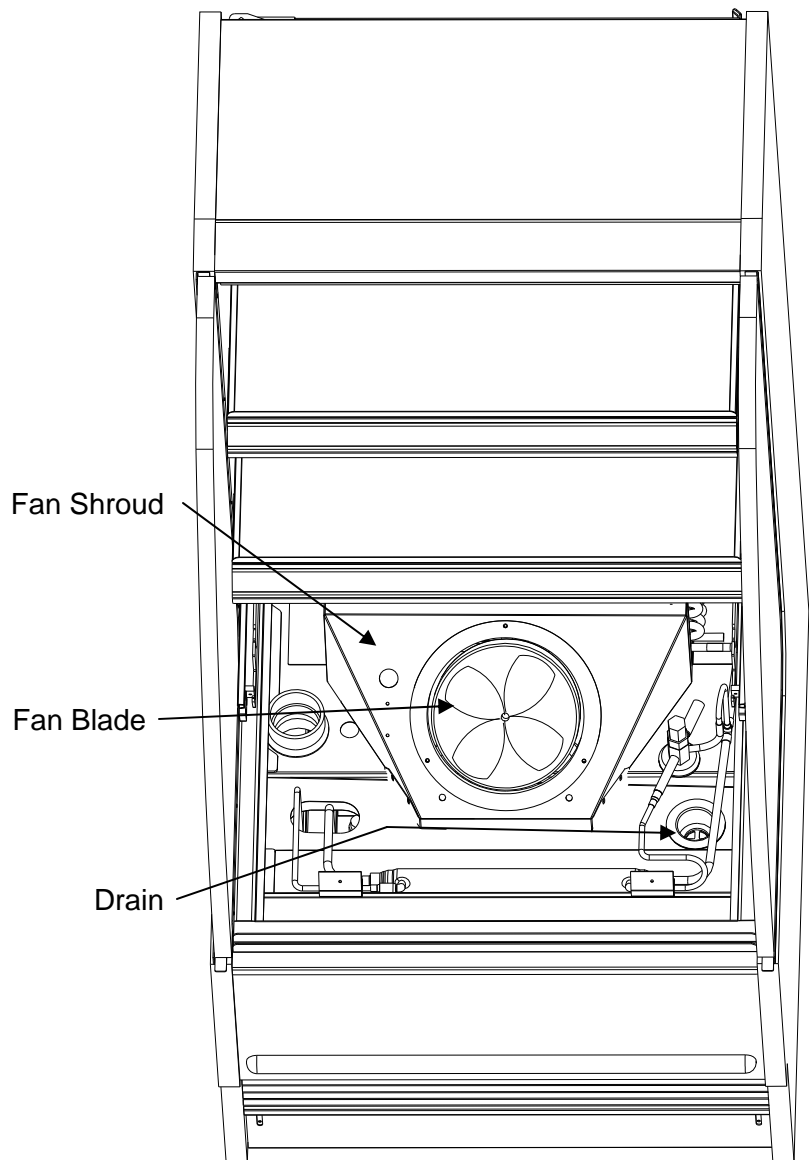

## DRAIN, HOSE AND BRACKET PLACEMENT ILLUSTRATIONS

**NOTE: BELOW ILLUSTRATIONS MAY NOT EXACTLY REFLECT EVERY PARTICULAR CASE'S FEATURES**

### Three Evaporator Systems Are Illustrated Below:

**Illustration #1:** Hot Gas "CopeVap" Evaporator System. "Copevap" is built into Compressor Unit.

**Illustration #2:** Hot Gas Evaporator System.

**Illustration 3A/3B:** Electrical Heat Rod Evaporator System. **Note:** Separate Evaporator Pan.

**Warning!** Regardless of Evaporator, the Hose and Drain Trap **MUST BE** secured and positioned over Evaporator Pan to prevent water seepage / spillage. When sliding out Condenser Unit, be careful that drain is not pulled from proper position.

### 2. Hot Gas Evaporator System.

- Hot gas serpentine coil is routed through a condensate reservoir allowing water to be heated. This system uses a wicking material (partially submersed) with warm condenser air passing through it for evaporation.
- Also incorporates an overflow reservoir with heating element to ensure complete condensate removal.

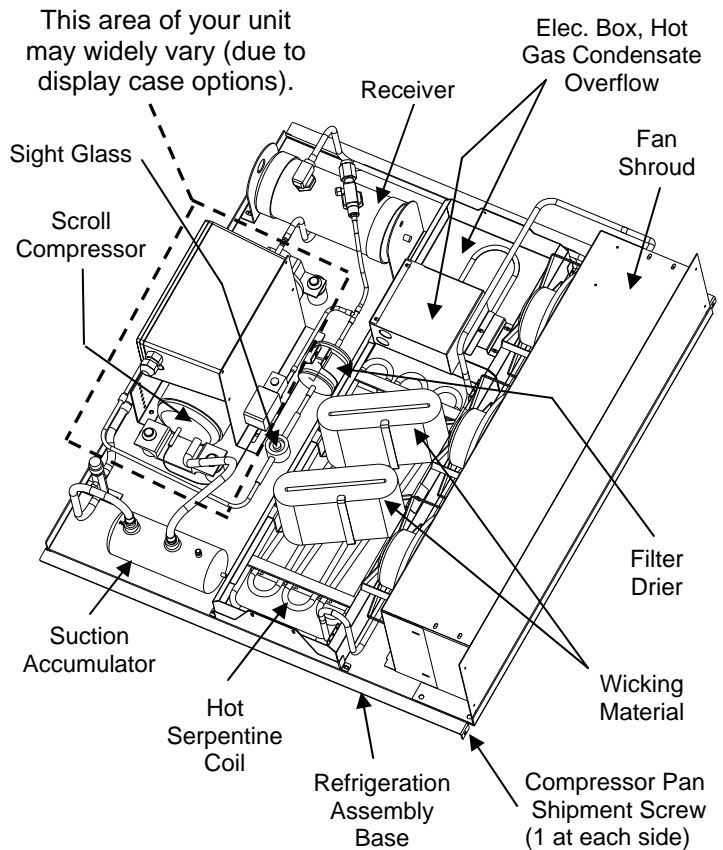

**Note:** Drain positioned directly over Reservoir

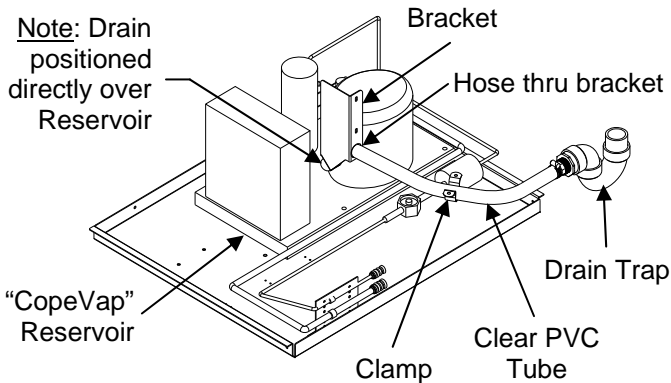

1. Hot Gas "CopeVap" Evaporator System.

Use Hose Clamp to Secure Hose to Adapter

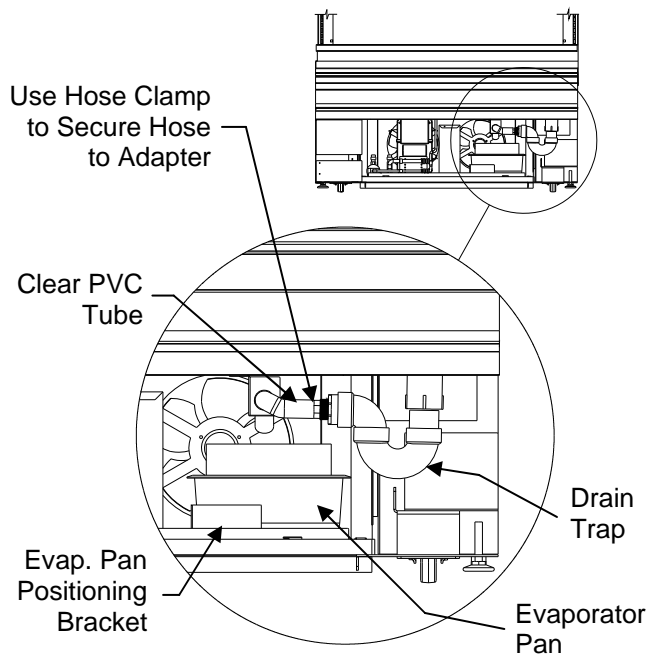

3A. Front View of Electrical Heat Rod Evaporator System

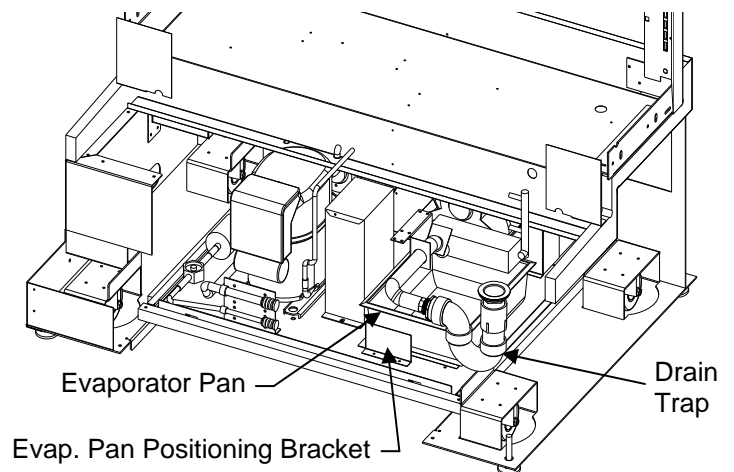

3B. Isometric View of Electrical Heat Rod Evaporator System

**1. Position & Align Case Alongside Other Cases**

- Before adjusting levelers, make certain that the case is in proper position and, if required, aligned with adjoining case.
- This may require the repositioning of the case you are installing or the already positioned case.

**2. Adjust Levelers**

- See illustrations and photos at right.
- **Note:** Depending upon options and features chosen, illustrations may not exactly reflect your particular case's features.
- After case is in proper position, adjust case so it is level and plumb (see illustrations at right).
- You may need to remove front and/or rear Toe-Kick to access levelers.
- Use adjustable wrench to adjust leveler.
- Depending upon case weight, it may be necessary to use a Pry Bar to raise the case.
- Do not use Pry Bar on Toe-Kick as it may buckle.
- Do not use Pry Bar on End Panel; it may chip.
- Use Pry Bar **ONLY** on Base Frame to avoid damaging case.

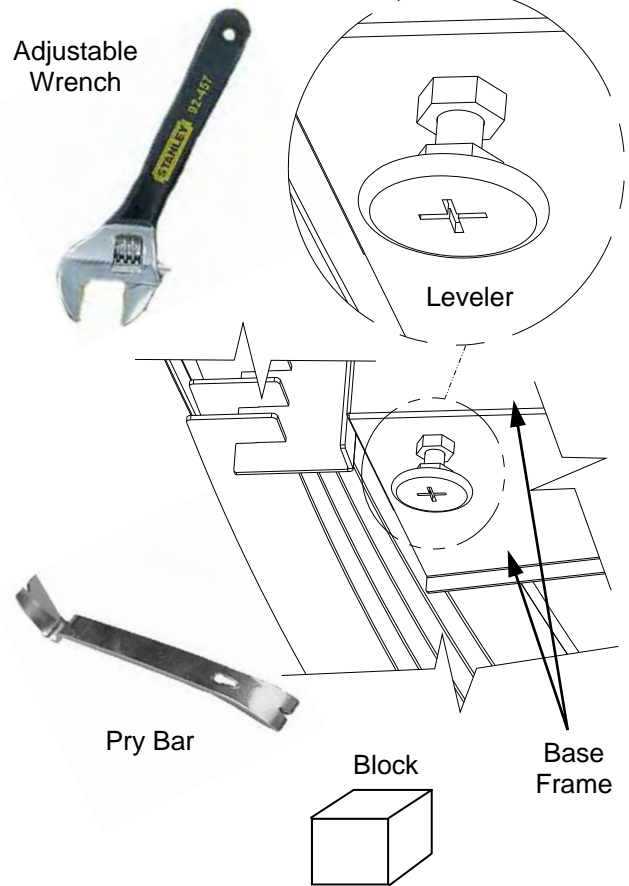

**3. Frame Support Rails Must Be Shimmed**

- Illustration below shows frame support rails.
- Shims will be provided with all cases that have frame support rails.
- Use shims to level case.
- **Note:** After case is in position, it must be sealed to floor to prevent entry or leakage of liquid or moisture.

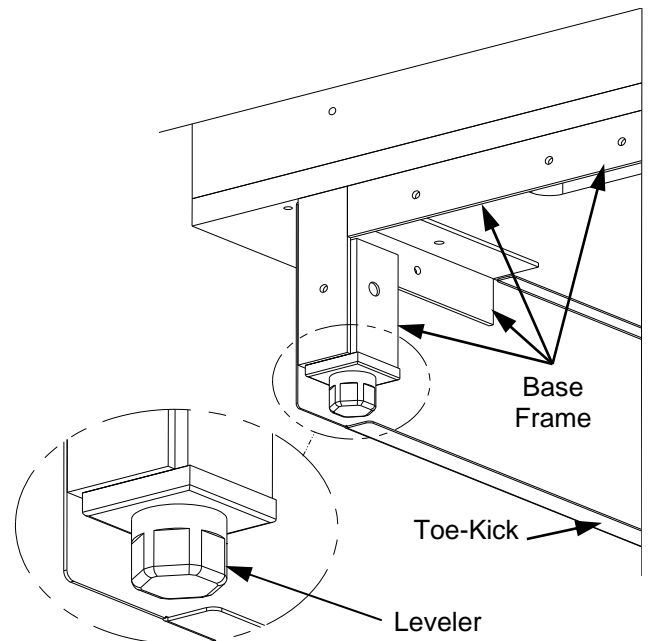
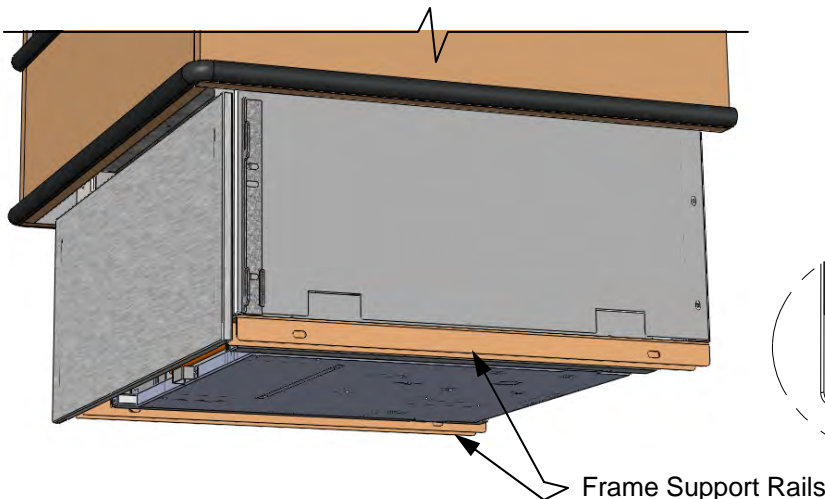

## ADJUSTING TOE-KICK / REMOVING FRONT GRILLE

### 1. Adjusting Toe-Kick

#### Model HMO2653R

- See illustration at top-right.
- Loosen adjustment screws located on toe-kick.
- Adjust Front Toe-Kick up or down.
- Tighten Adjustment Screws.

### 2. Removing Front Grille

#### >> Grille Removal (With Screws)

- Remove front grille retainer screws (both horizontal and vertical). See illustration at mid-right.
- Front Grille will fall forward and can be lifted up and away from case.
- Replace Front Grille in reverse order it was removed from case.
- Tighten retainer screws.

#### >> Grille Removal (Without Screws)

- Front grille is held in place with retaining hooks.
- Simply lift front grille up and off case.
- No screws are required for this particular grille.
- See illustration at lower-right.

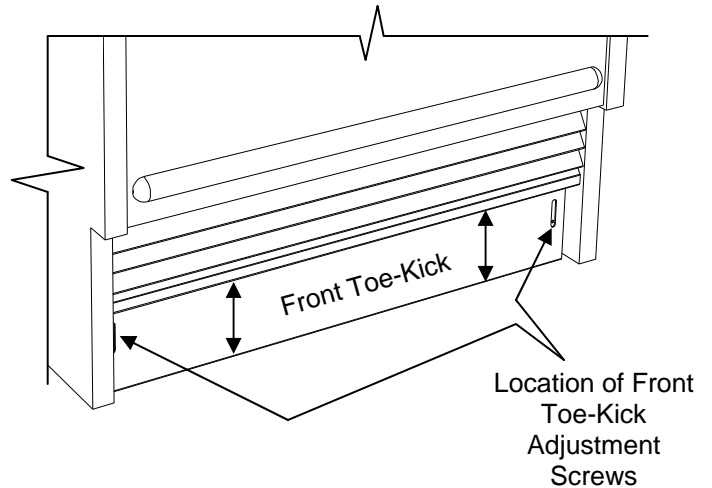

Front Grille Horizontal Retainer Screws  
(One at Each End of Case)

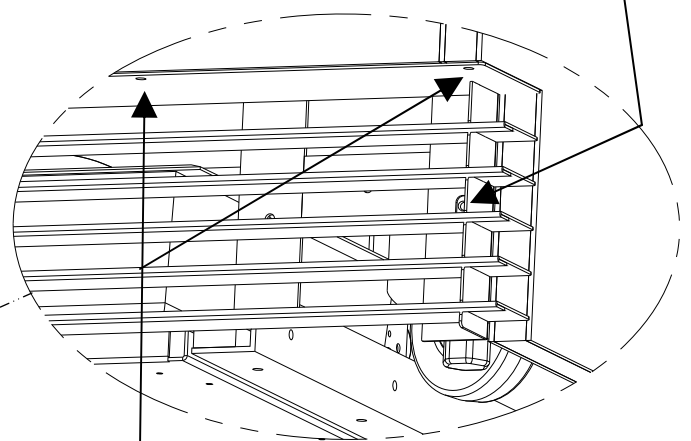

Front Grille Vertical Retainer  
Screws (Along Entire  
Underside of Front Panel)

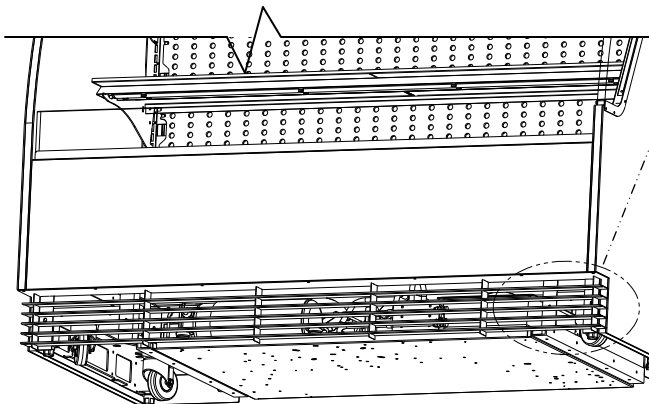

Front Grille Retaining  
Hooks (At Each End  
of Grille)

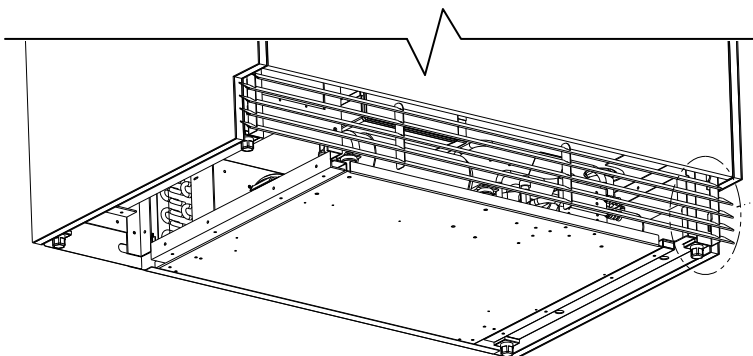

# REAR FILTER / GRILLE / PANEL ACCESS AND REMOVAL / COMPRESSOR PAN SHIPMENT SCREWS

## **1. Magnetized Condenser Coil Filter (Optional)**

- Removable magnetized condenser coil filter is positioned on outside of rear grille.
- It is held in place with magnetic strips.
- It may be removed for cleaning or service.

- Due to location, a Phillips™ (not flat-head) screw with extension may be required.
- See illustration at lower-right.
- For specifics on refrigeration package and its components, see next page.

## **2. Rear Grille**

- Rear grille may be removed by lifting grille slots up and off rear panel's retainer hooks.

## **3. Rear Panel**

- Rear panel is held in place with four Phillips™ (not flat-head) screws (which may be removed).

## **4. Compressor Pan Shipment Screws**

- Note: At initial access to refrigeration package, it may be necessary to remove compressor pan shipment screws.

Removable, Magnetized Condenser Coil Filter (Optional). Note: Filter is to be Placed on Outside of Rear Grille

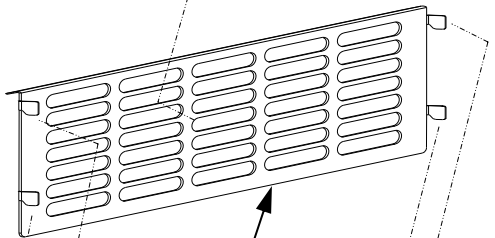
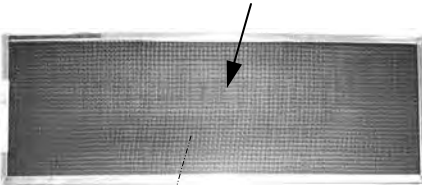

Rear Grille  
(Removable by Hooks)

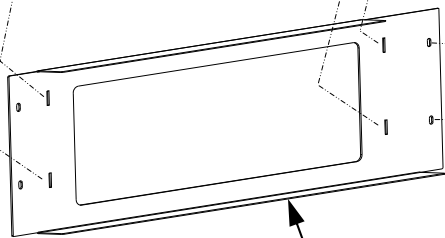

Rear Panel  
(Removable by Screws)

Enlarged View of Rear Grille Panel  
(and Grille) Shown Above

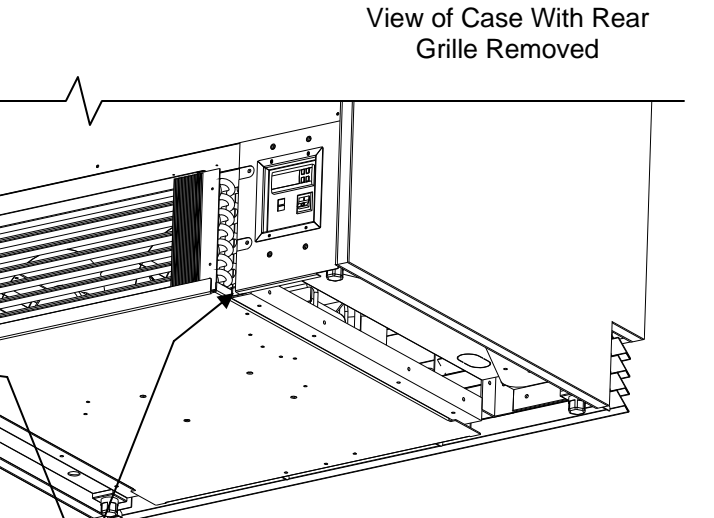
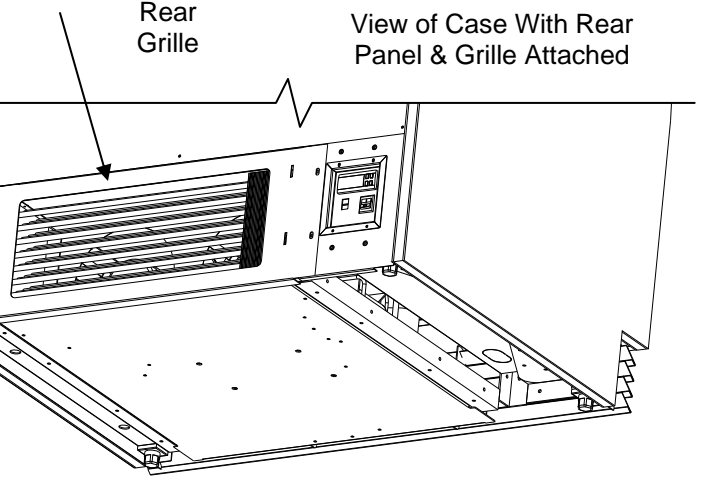
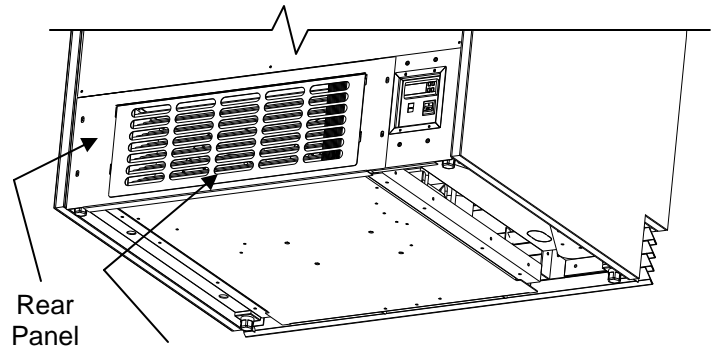

Compressor Pan Shipment  
Screw (One at Each End)

## START-UP AND OPERATION

### 1. Merchandiser Start-Up

- Remote Units: Case is hard-wired. When power is supplied, case will power-up.
- Self-Contained: Main Power switch is located at case rear, lower right. See illustration below.
- Self-Contained: Temperature Controller is located at case rear, lower left. See the illustration shown below.
- Turn on the lights. Whether Remote or Self-Contained, light switch is located on inside of case at top right, from case rear. See illustration at top right.
- All lights should come on at same time. First time lighting may require a short warm up period for the bulbs. Slightly dim or a flickering of new bulbs is normal.
- The lighting is wired in series so **all lights must be plugged in or receptacles capped** for case lights to turn on.

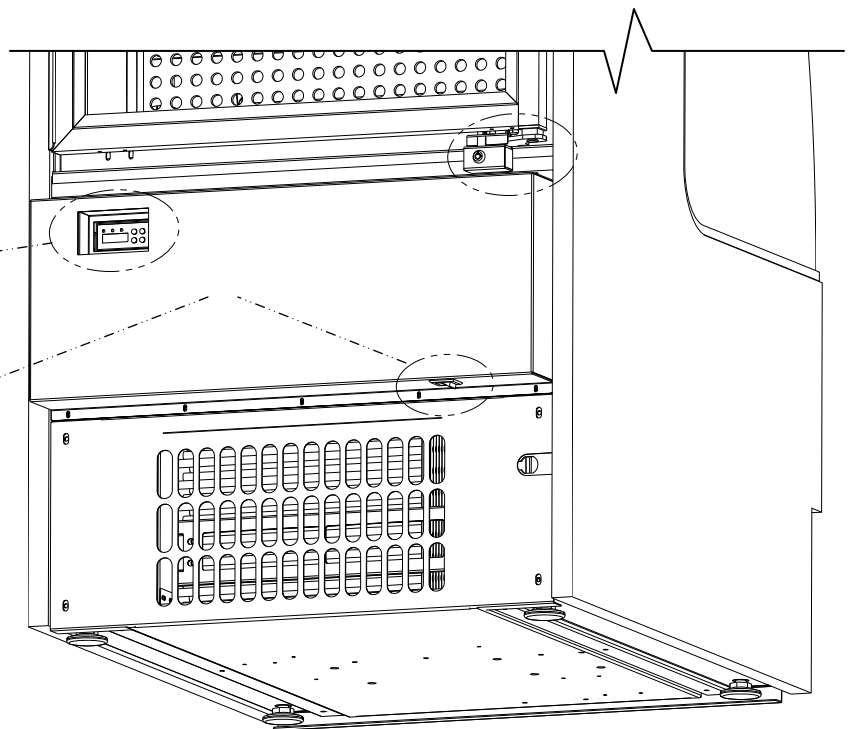
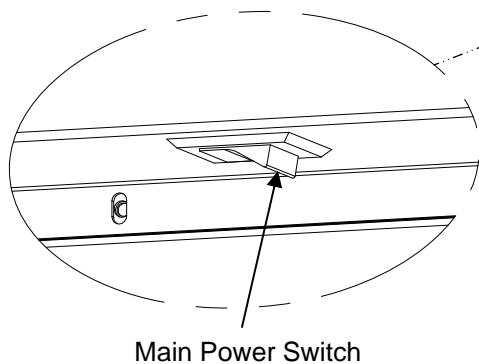
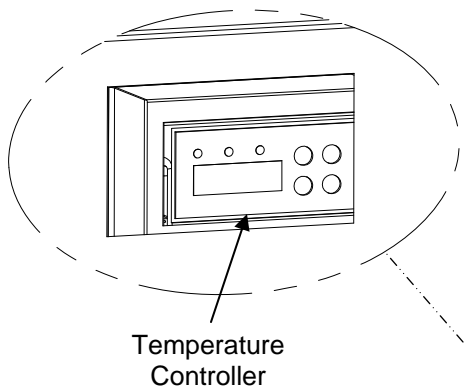
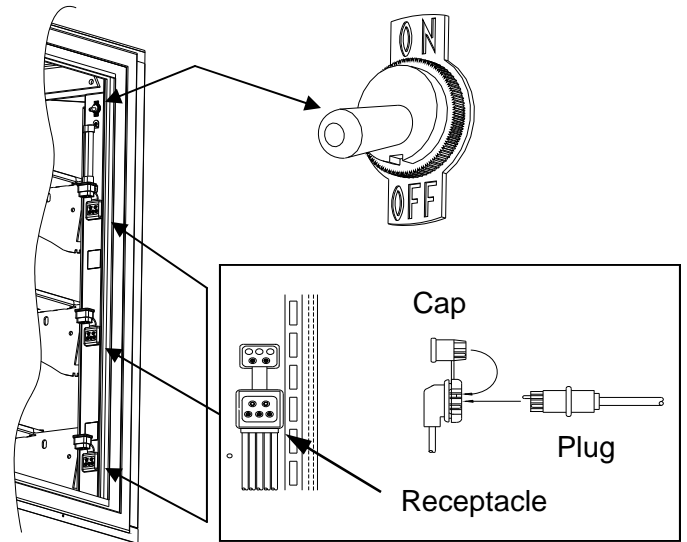

## START-UP AND OPERATION, CONTINUED: NIGHT AIR CURTAIN OPERATING INSTRUCTIONS

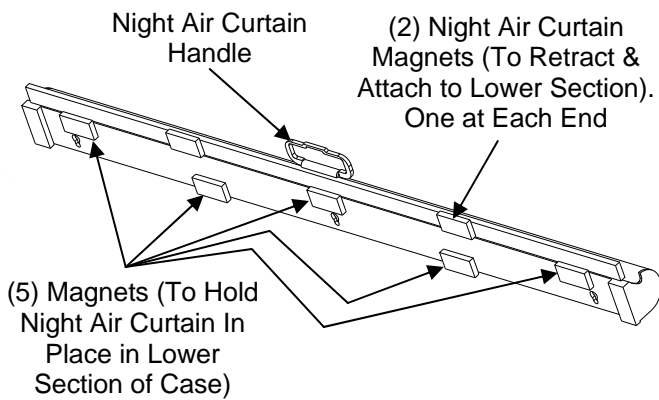

Underside View of Detached Night Air Curtain

### 2. Night Air Curtain Operating Instructions

1. Use caution when handling Night Air Curtain. See view of detached Night Air Curtain at top-left.
2. Display case comes with Night Curtain already attached.
3. Attachment Magnets will hold Night Air Curtain firmly in place.
4. Grasp the handle at lower-front-center area of case (shown in enlarged view at lower-left) and pull upward.
5. When extended, the Night Air Curtain magnets may be attached to metal plate in front of honeycomb (as shown below).
6. Magnets (on extended night air curtain) will hold it firmly in place.
7. To return Night Air Curtain to its original position, grasp handle, and lift up and off from its magnetic attachment and carefully wind Night Air Curtain back into roll (into lower section of case).
8. **Caution!** Do not allow spring-loaded Night Air Curtain to freely snap back into roll. Doing so can eventually destroy Night Air Curtain's tension and retractability.
9. **Caution!** Do not slide or drag Night Air Curtain across metal plate (in front of honeycomb) when extending and attaching. Lift end of curtain (and its magnets) straight up and off metal housing to avoid scratching or marring surface.

Night Air Curtain Handle

Night Air Curtain General Location for Attaching Retaining Magnets

Night Air Curtain Projected Arc From Lower Section

Side View of Attached Night Air Curtain (With End Panel Removed)

Night Air Curtain Roller and Housing

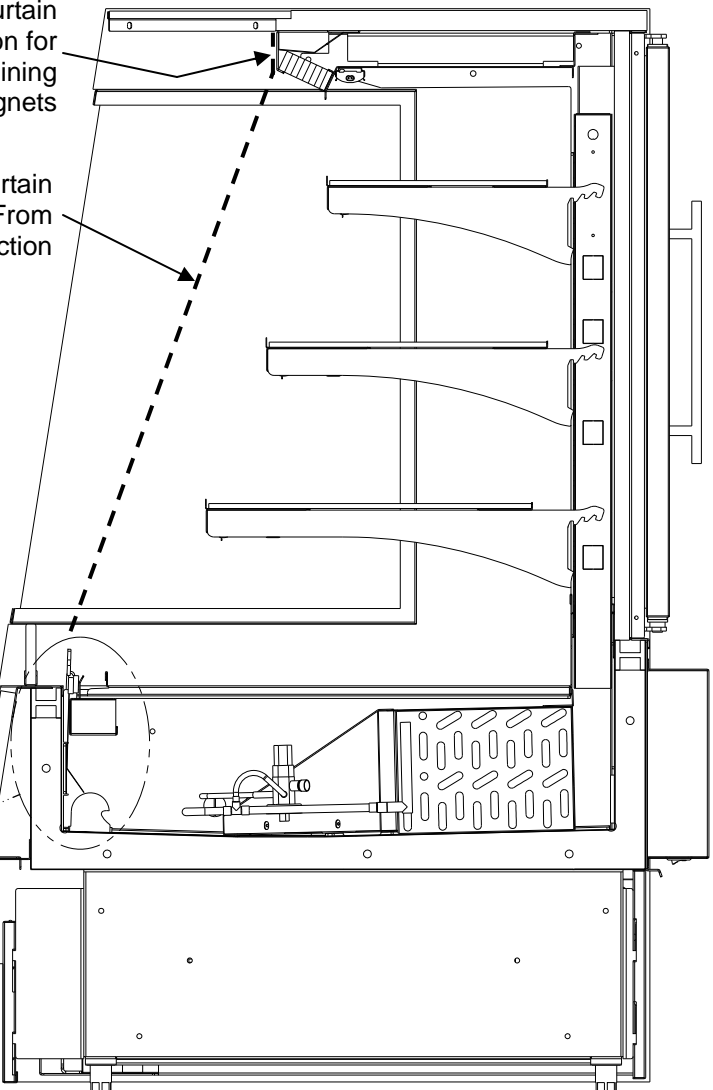

**1. Solid Rear Door**

- Illustration below shows standard door for a specific model. Your model may not reflect this feature.
- See next page for case with rear door with

access to perforated Plexiglas® plenum (designed to assist in air flow issues).

- **Caution:** Door is designed to open at a specific arc. Do not attempt to open door beyond this arc or you could damage hinges or door!

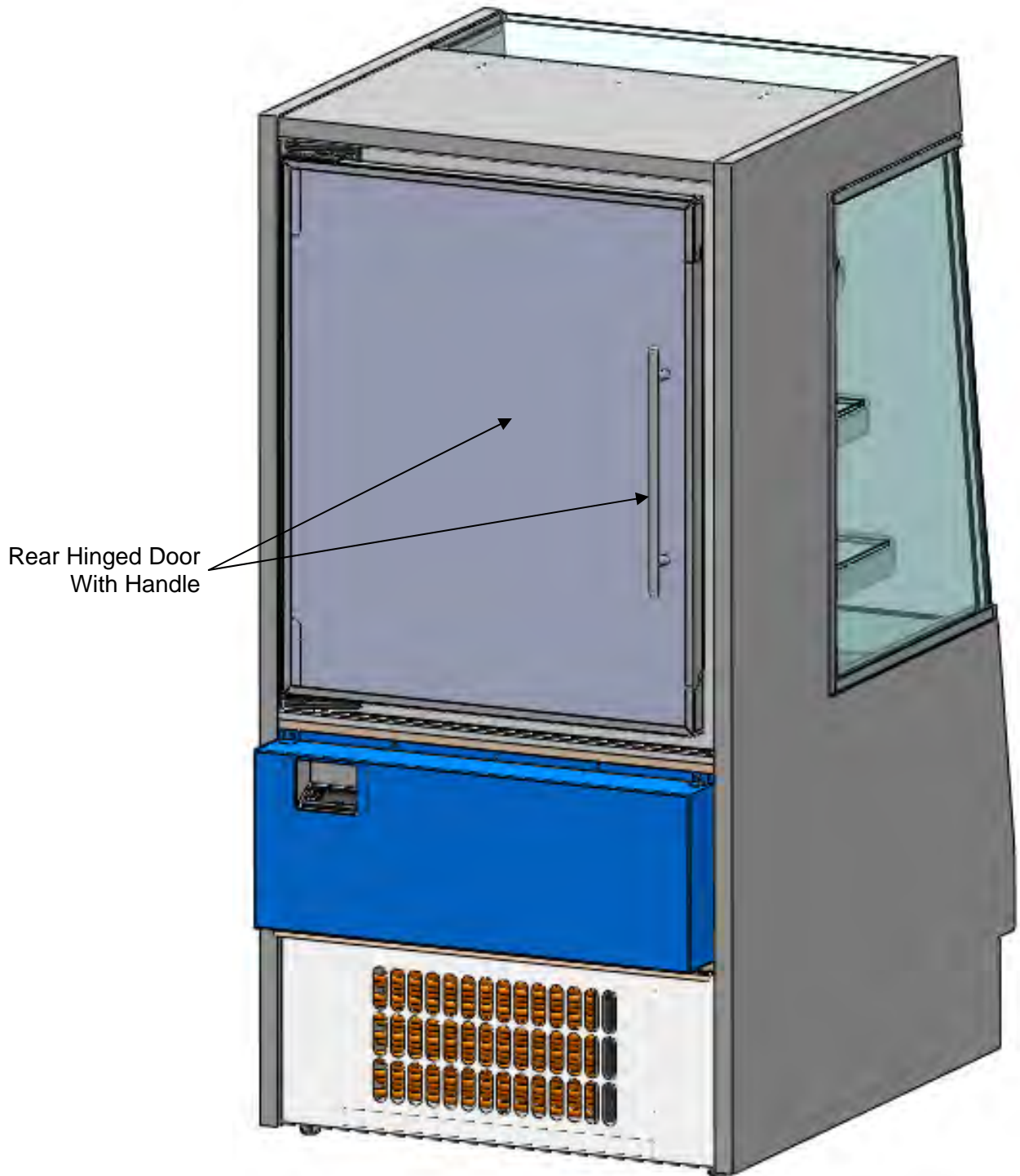

## **2. Perforated Plexiglas® Plenum**

- The perforated Plexiglas® plenum is designed to assist the case in proper air flow.
- The Plexiglas® plenum may be removed (for cleaning, etc.) by opening the rear door and sliding up and out of frame.
- **Caution:** See cleaning instructions in this manual for specifics on cleaning the Plexiglas® plenum
- See illustration below.
- **Caution:** After cleaning, carefully replace perforated Plexiglas® plenum back into frame. Avoid scraping or marring the surface.

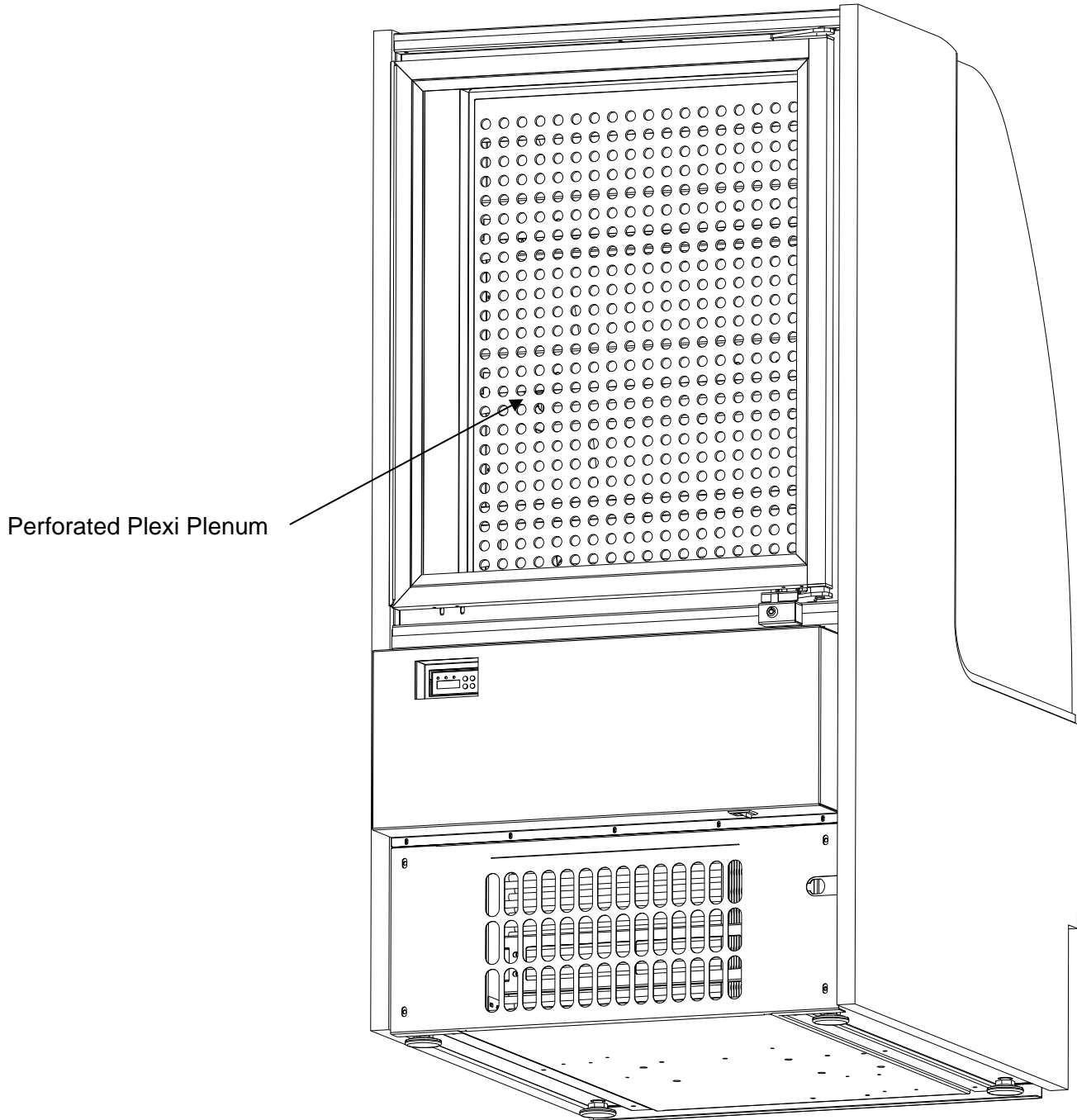

## REAR SLIDING DOOR WITH ADJOINED PERFORATED PLEXIGLAS® PLENUM (MODEL HMO3953R)

### ***Rear Sliding Door With Adjoined Perforated Plexiglas® Plenum***

- The perforated plexiglas® plenum is designed to assist the case in proper air flow.
- Two metal adjoiner brackets connect each door to its adjoining perforated Plexiglas® plenum.
- Adjoining Bracket Connects Rear Sliding Doors to perforated Plexiglas® Plenum
- See previous page for instructions on removing perforated plexiglas® plenum (for cleaning, etc.).
- **Caution:** See cleaning instructions in this manual for specifics on cleaning the plexiglas® plenum. Using cleaning solutions that are not listed in this manual can mar plexiglas® surface.
- **Caution:** After cleaning, servicing, etc., carefully replace perforated plexiglas® plenum back into display case. Avoid scraping or marring the surface.

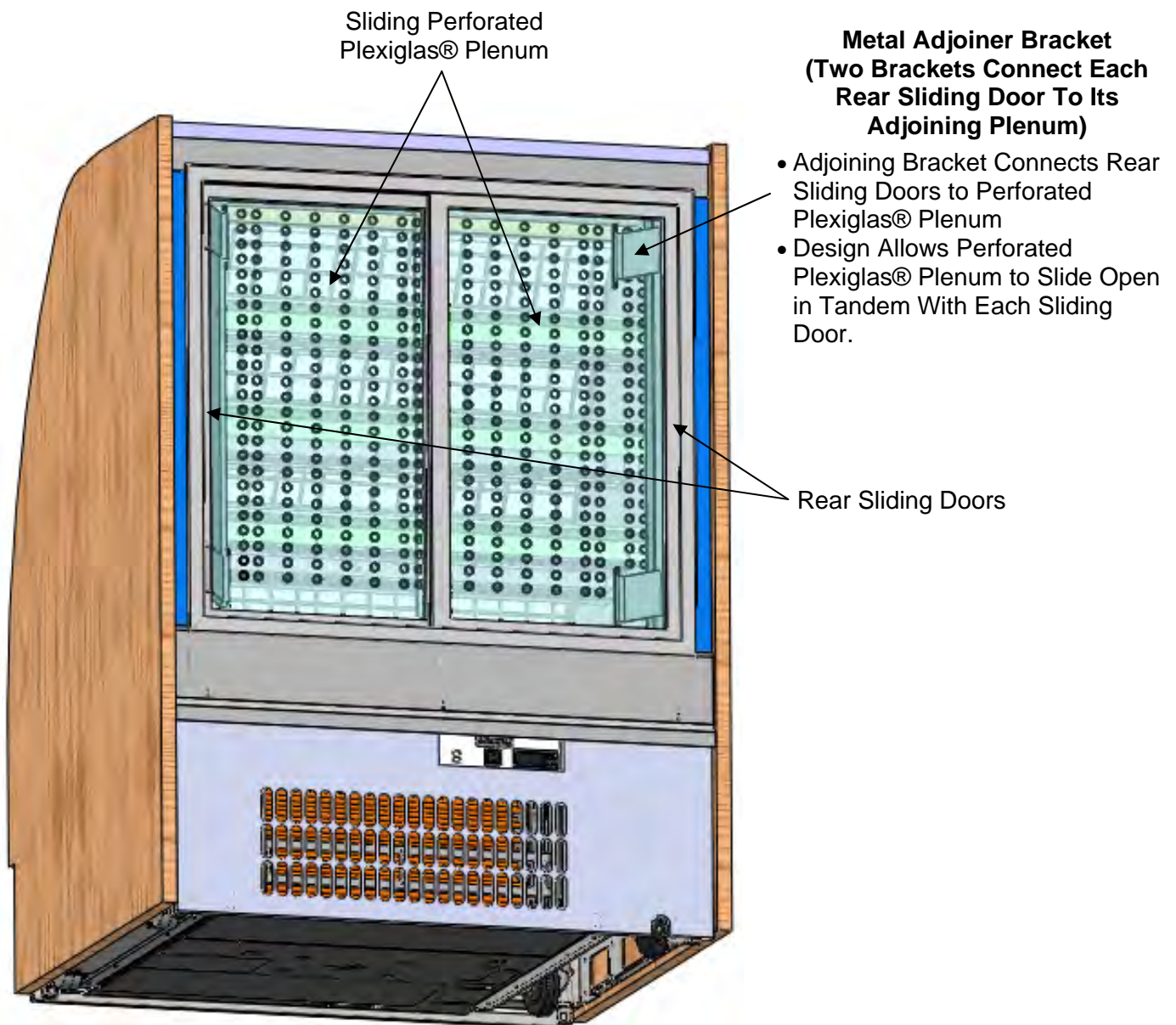

**1. Initial Positioning and Installation of Security Grid**

1. Due to weight and size, Security Grid installment requires two (2) people.
2. After hoisting the Security Grid directly over Front Air Deflector, drop the (2) Security Grid Positioning Tabs into the Baffle Airflow Slots (see enlarged view below).
3. After securely positioned in the Baffle Airflow Slots, carefully and slowly lean the Security Grid back against the two Security Brackets.
4. The next page in this manual will show how to secure the top of the Security Grid to the Security Brackets.

**NOTE: ILLUSTRATIONS MAY NOT EXACTLY REFLECT EVERY PARTICULAR CASE'S FEATURES**

**Enlarged View (Below)**

- Enlarged View (shown below) shows Security Grid Positioning Tab slid into Baffle Airflow Slot.
- There is one Security Grid Positioning Tab on each Security Grid end.
- Tabs must be securely positioned in both Airflow Slots prior to locking with Padlocks.

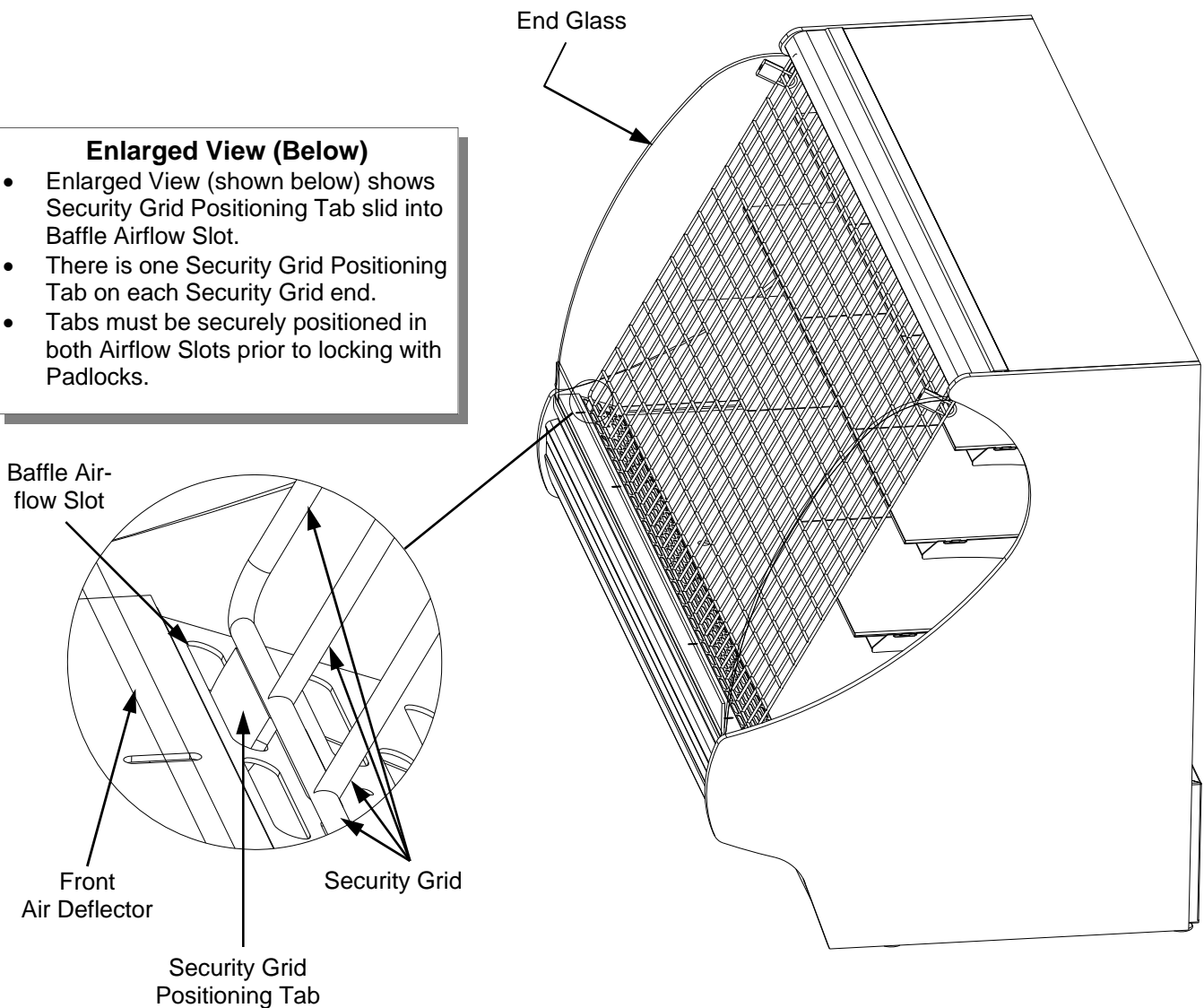

**2. Securing Security Grid Into Place and Locking**

1. After leaning the Security Grid back against the two Security Brackets, slide the (two) Padlocks through the Security Grid and the Security Brackets.
2. Securely lock the Padlocks (one Key fits both Padlocks).

**3. Removing and Storing Security Grid and Locks**

1. Due to weight and size, Security Grid removal requires two (2) people.
2. Unlock and remove Padlocks. Lean Security Grid forward. Lift upward and out of Baffle Airflow Slots.
3. Store Security Grid, Padlocks and Keys in a secure location to prevent theft or damage.

**NOTE: ILLUSTRATIONS MAY NOT EXACTLY REFLECT EVERY PARTICULAR CASE'S FEATURES**

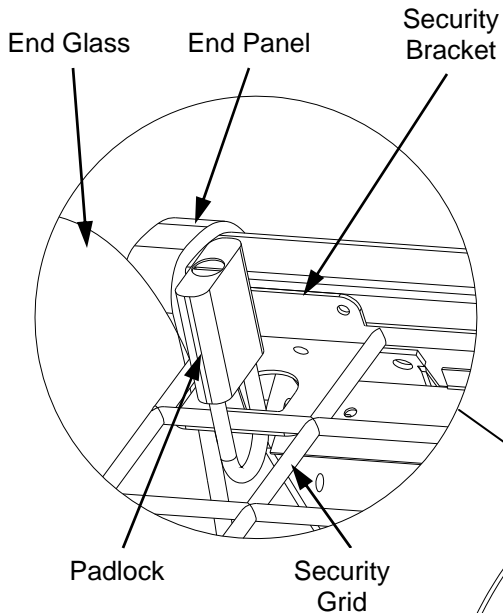

**Enlarged View (At Left)**

- Enlarged View (at left) shows Padlock through Security Grid and Security Bracket.
- One Security Bracket is at each end of Case.

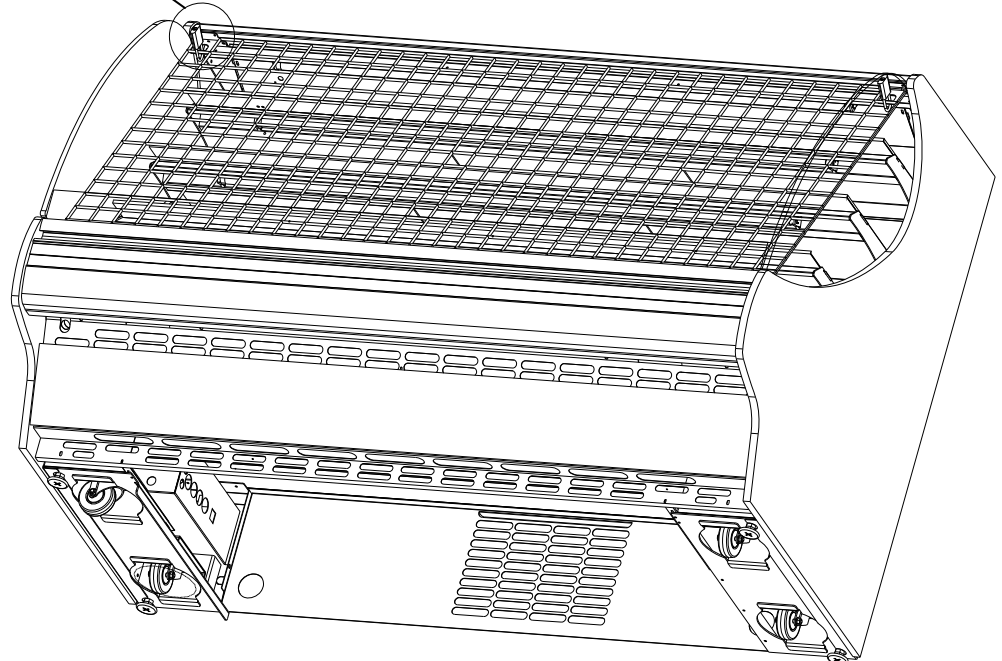

**Note:** Both Casters and Levelers shown for illustrative purposes only.

## OPTIONAL NIGHT AIR CURTAIN INSTALLATION & OPERATING INSTRUCTIONS

### **Night Air Curtain Installation & Operating Instructions**

1. Use caution when handling Night Air Curtain.
2. Display case may come with Night Curtain already attached. If not, a retrofit kit will be provided. If using SCC-supplied retrofit kit, attach to display case by centering night curtain along angled Honeycomb Support (as shown in illustration below). Attachment Magnets will hold Night Air Curtain firmly in place.
3. Grasp the handle and pull downward to desired area **OUTSIDE** acrylic sneeze guard.
4. To return Night Air Curtain to its retracted position, grasp handle, lift up and away from its magnetic attachment and carefully wind Night Air Curtain back into roll.
5. **Caution!** Do not allow spring-loaded Night Air Curtain to freely snap back into roll. Doing so can eventually destroy Night Air Curtain's tension and retractability.
6. **Note:** Due to **ONLY** the magnets keeping Night Air Curtain Assembly in place, it may be removed at any time by firmly lifting up and off Night Air Curtain Support.
7. **Caution!** Do not slide or drag Night Air Curtain from unit while removing. Lift curtain straight up to avoid scratching or marring honeycomb support surface.

***NOTE: THE  
BELOW  
ILLUSTRATION  
MAY NOT  
EXACTLY  
REFLECT  
EVERY  
PARTICULAR  
CASE'S  
FEATURES  
OR  
OPTIONS.***

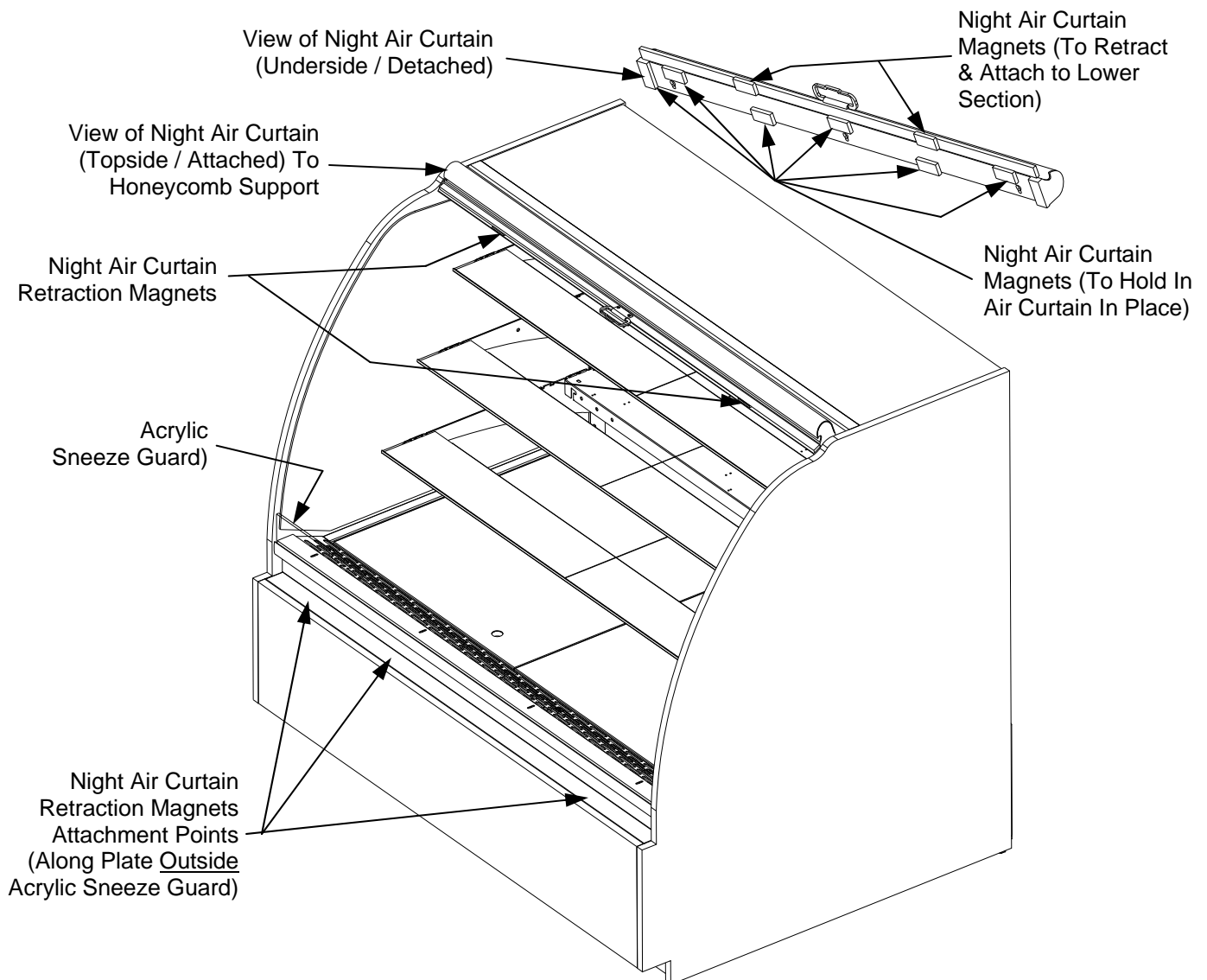

**1. Shelf Assembly Removal**

- Remove glass shelves
- For lighted shelving, unplug the light cord.
- Lift light shelf upward to separate from brackets.
- Remove rear shelf support
- Remove brackets. Note it may be necessary to remove the nylon shipping bracket retainer. Pliers will be required to accomplish this task.

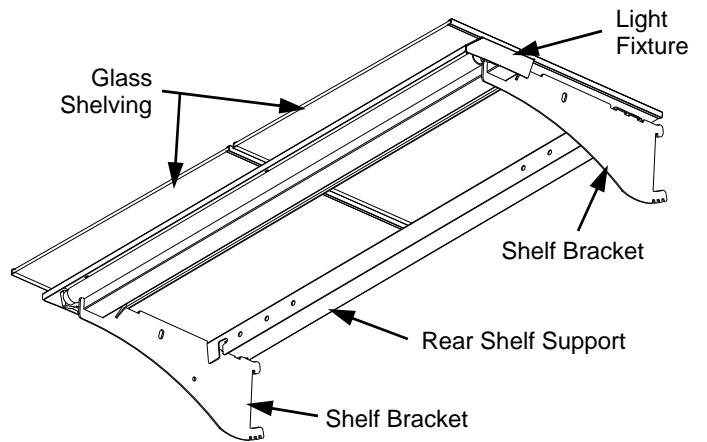

**2. Light Fixture**

Removal of lamp:

- Rotate lamp (1/4-turn) either direction to disengage (upper or lower) pins/contacts from lamp mounting sockets.
- Remove bulb by applying even pressure from the back side at the bulb ends and pulling the remaining contact from the sockets.

Installation of lamp:

- Align pins with slot.
- Insert pins into socket by rotating the bulb 1/4 turn to secure either the (upper or lower) pinned contacts into the sockets.
- Rotate the remaining bulb contacts (1/4 turn) into the remaining lamp-mounting socket contacts.
- See illustration below.

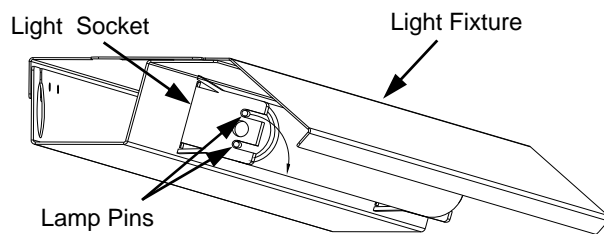
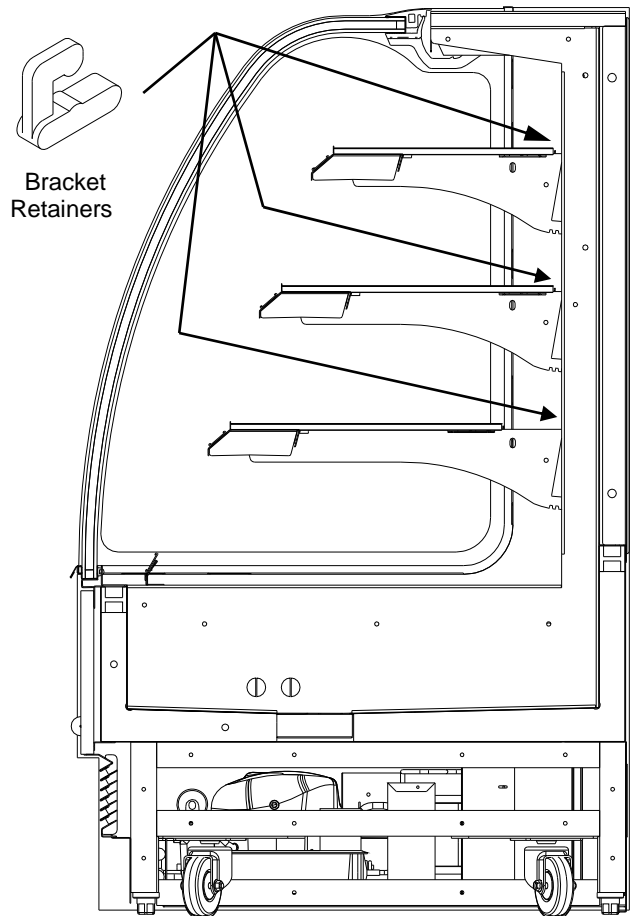

Above Photo Illustration shows Light Fixture. To remove lamp, simply rotate lamp clockwise and out. To replace, place one set of pins into slots and rotate second set of pins into slots.

**3. LED Light Removal / Replacement**

- If case is provided with LED lights they will rarely require change-out.
- Contact Structural Concepts' Technical Service Dept. for replacement parts (see Technical Service section of this guide).
- To remove LED light fixture, disconnect existing LED light from its brackets and self-adhesive tape.
- Then, firmly grasp LED light while applying outward pressure to brackets.
- Twist the LED out and away from the bracket to release
- See illustrations at right.

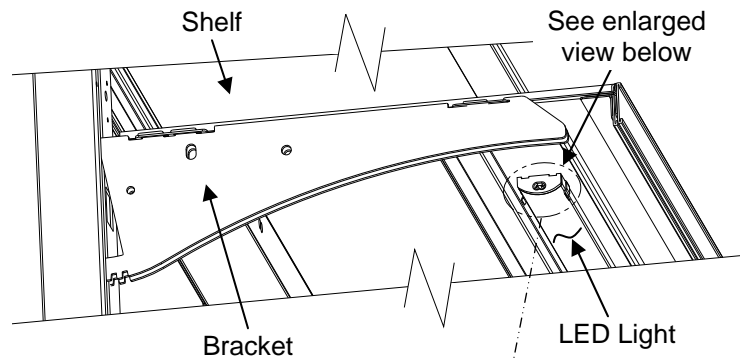

**4. Plug And Cord Positioning**

- Plug is to connect to LED light at raceway side of case.
- Before attaching LED light to case, verify that plug connects to LED properly (without cord doubling-back).
- See photos of proper vs. improper connections at right.

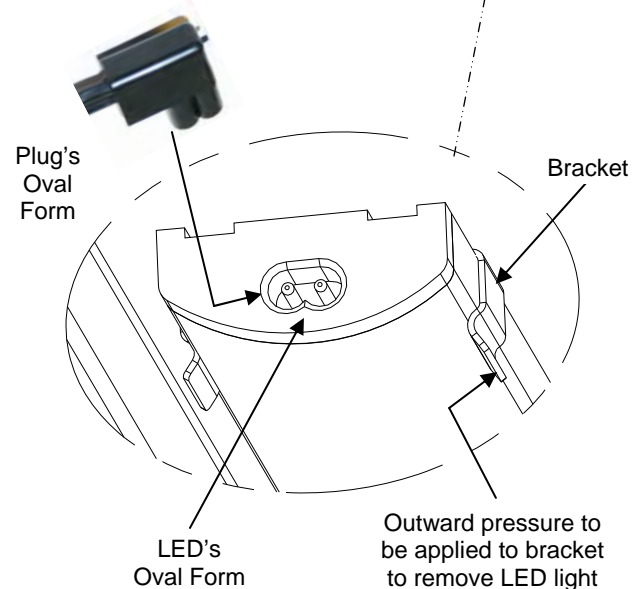

**5. Proper Plug Insertion Into LED Light**

- Plug must be inserted into LED light properly or the LED will not light up.
- Oval form of plug is to connect to the oval form of LED light.
- See illustration at right.

See previous page for Standard Light Fixture information.



Proper Connection



Improper Connection

**Refrigeration Package Configuration**

- Illustration shown is from model HMO2653R.5194.
- Your particular refrigeration package may have different refrigeration package layout.
- Wicking material (shown below) is optional.
- See ***DRAIN, HOSE AND BRACKET PLACEMENT ILLUSTRATIONS*** section in this manual for other refrigeration layouts.

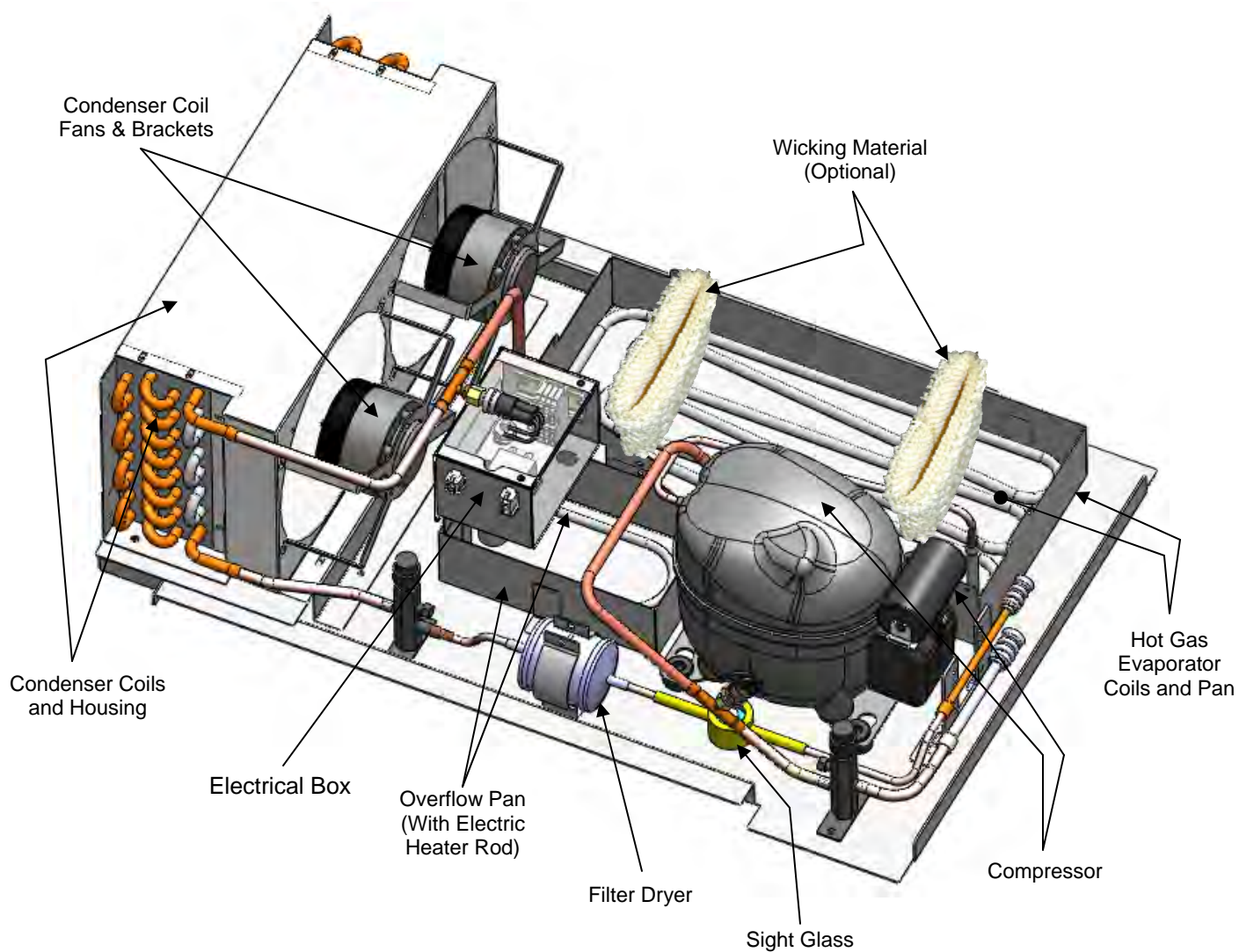

**GENERAL CLEANING (TO BE PERFORMED BY STORE PERSONNEL)**

AREA TO CLEAN	FREQ.	INSTRUCTIONS
Case Exterior	Daily	<b>Acrylic:</b> Acrylic sneeze guard must be cleaned with a mild soap and water solution and a soft cloth. <b>Caution! Never use ammonia-based cleaners on acrylic. Incorrect cleaning agents or abrasive cleaning cloths cause surfaces to 'cloud' over time.</b>
	Daily	<b>Glass (Including Glass Shelves):</b> Clean side glass, front curved glass and rear glass with a household or commercial glass cleaner and soft cloth.
	Daily	<b>Wood/Laminate/Painted Surfaces:</b> Clean wood, laminate and painted surfaces with a warm soap and water solution and soft cloth. Never use wire cloth or abrasive cleaners on case.
	Daily	<b>Stainless Steel Surfaces:</b> See next page for complete instructions.
	Weekly to Monthly	<b>Air Filter (With Magnetic Strip) on Rear Grille (Optional):</b> <ul style="list-style-type: none"> <li>• Depending upon environment, it may be necessary to clean filter as often as weekly. Filter <b>MUST</b> be cleaned at least monthly.</li> <li>• Remove from case. Submerge in warm, soapy water. Use soft-bristled brush to remove dust, grease and grime that collects on filter. Rinse thoroughly. After filter has dried, return to case.</li> <li>• See <b>REFRIGERATION FUNDAMENTALS</b> section in this manual for illustrations.</li> </ul>
Case Interior	Daily	<b>Shelves/Decks/Risers:</b> Shelves, decks and risers can be cleaned with a warm soap and water solution. For stubborn stains/residue, decks and riser can be removed and cleaned with soap and water solution or submersed in hot, soapy water solution. Rinse thoroughly. Dry. Return to case.
	Daily	<b>Glass Behind Rear Plenum (Certain Cases):</b> Remove glass shelves and brackets. Remove rear plenum (see <b>PERFORATED PLEXIGLAS PLENUM - MODEL HMO5153R.4509 &amp; HMO6353R.4577</b> section for removal instructions). Clean rear glass with a household or commercial glass cleaner and soft cloth. Replace brackets and glass shelves when complete.
	Weekly	<b>Shelf Supports / Air Return Grilles / Decking</b> <ul style="list-style-type: none"> <li>• Wipe off shelf supports, air return grilles and decking with moist cloth.</li> <li>• Shelf supports can be removed for more thorough cleaning.</li> <li>• Air return grilles can be removed for more thorough cleaning.</li> <li>• Decking is NOT to be removed by store personnel.</li> </ul>
	Monthly	<b>Condenser Coil:</b> Vacuum or brush grille condenser coil at case front. Use metal or fiber brush to remove dust and dirt that can collect on condenser coils. Be careful not to damage the fins on the coil. See <b>INSTALLATION</b> section in this manual for instructions on side panel removal.

## CLEANING SCHEDULE - STAINLESS STEEL (TO BE PERFORMED BY STORE PERSONNEL)

### General Stainless Steel Surface Cleaning (To Be Performed As Often As Needed):

- Certain grades of stainless steel, and some are more prone to corrosion than others.
- Stainless steel can become exposed to a wide variety of contaminants, which if left untreated can cause stains and rust.
- Stainless steel requires a specific cleaning procedure to maintain its sheen and remain rust-free.
- Wash with a solution of liquid dishwashing detergent and hot water.
- Rinse with pure hot water from spray bottle. Wipe with clean sponge. This will remove soap residue that can lodge in stainless steel's microscopic grooves, causing rust.
- Dry with clean, soft cloth or paper towel.
- ***Caution!*** To prevent rust, you ***MUST*** rinse with pure hot water from a spray bottle while wiping with clean sponge after EACH cleaning.
- ***Caution!*** Never clean with scouring powder or steel wool as they can mar, scratch and/or erode the surface of stainless steel. When the surface properties of stainless steel have been compromised, rust can form.

### Brightening:

- **Method 1:** Brighten by polishing with a soft cloth or sponge with a solution of one part vinegar to 2 parts water in a spray bottle.
- **Method 2:** Sprinkle baking soda on sponge and rub gently with soft cloth or sponge.
- ***Caution!*** To prevent rust, you ***MUST*** rinse with pure hot water from a spray bottle while wiping with clean sponge after EACH cleaning.
- Dry with clean, soft cloth or paper towel.

### Removing Streaks or Stains:

- **Method 1:** Place two teaspoons of rubbing alcohol on a microfiber cloth or pad. Rub the cloth along the grain of the appliance until the entire area has been wiped. The rubbing alcohol will air dry itself.
- **Method 2:** Dip soft cloth or sponge in club soda and rub gently over area of concern.
- ***Caution!*** To prevent rust, you ***MUST*** rinse with pure hot water from a spray bottle while wiping with clean sponge after EACH cleaning.
- Dry with clean, soft cloth or paper towel.

### Polishing:

- Place a dab of olive oil onto clean soft cloth. Spread over area until a light sheen is observed. Use pressure to "work the oil" into the small grooves in the surface. Apply firm, steady pressure using small circular motions.
  - > **Dry buff:** Remove excess oil with clean cloth or paper towel using small circular motions.
  - > **Wet buff:** Use an ounce or white vinegar with clean cloth or paper towel using small circular motions.
  - > Continue wiping until oily finish has been removed.
- ***Caution!*** To prevent rust, you ***MUST*** rinse with pure hot water from a spray bottle while wiping with clean sponge after EACH cleaning.
- Dry with clean, soft cloth or paper towel.

### Removing Rust:

- If rust has begun to form, there are a variety of products that can treat it.
- Among these are CLR® (calcium, lime and rust remover) and Chemetall Oakite 33 (rust, oxides and scale remover).
- ***Caution!*** To prevent food contamination, personal injury or further corrosion, carefully observe and follow the rust removing product's precautions and instructions.

## TROUBLESHOOTING (TO BE PERFORMED BY STORE PERSONNEL)

CONDITION	TROUBLESHOOTING
Case Is Not Level	See <b>POSITIONING &amp; ALIGNING CASE / ADJUSTING LEVELERS</b> section in this manual for additional information.
Water Is On The Floor	Call service provider.
Fan Emits Excessive Noise	Call service provider.
Case Lights Are Not Working	Check that light switch is in the <i>on</i> position.
	Check that ALL of the light cords and plugs are properly connected. See <b>MAINTENANCE - LIGHT FIXTURES (LED LIGHT FIXTURES)</b> section in this manual for specifics.
	If case lights still do not come on, call service provider.
Case is Not Holding Proper Temperature	If a large amount of warm product was added to the case, it will take time for the temperature to adjust. Product must be pre-chilled before placing in case.
	Check that the case is not in the sun or near a heat or air-conditioning vent. See <b>OVERVIEW / NSF® TYPE / COMPLIANCE / WARNINGS / PRECAUTIONS</b> section in this manual for specifics.
	Check that air filter and condenser coil has been cleaned. See <b>GENERAL CLEANING (TO BE PERFORMED BY STORE PERSONNEL)</b> section in this manual for specifics.
	Check air return grilles (area at front of decking) for obstructions. DO NOT set product on air grilles as this will prevent proper airflow!
	If case still is not holding proper temperature, call service provider.

**GENERAL CLEANING (TO BE PERFORMED BY TRAINED SERVICE PROVIDERS ONLY)**

AREA TO CLEAN	FREQUENCY	INSTRUCTIONS
Case Interior	Monthly	<p><b>Evaporator Fan Shroud Area (Under Decking):</b> <i>Caution! Due to rotating fans in area, turn off case and disconnect plug from wall outlet before beginning fan shroud (and surrounding tub area) cleaning!</i> 1) Turn off power. 2) Remove decks from case. 3) Clean fan shroud area (and surrounding tub area) with moist cloth.</p>
	Quarterly	<p><b>Tub &amp; Drain:</b> <i>Caution! Due to rotating fans in area, turn off case and disconnect plug from wall outlet before beginning tub &amp; drain cleaning!</i> Vacuum tub under decks. Clean with soap and water solution. Wipe dry with clean cloth. Keep drain free of debris to prevent clogging.</p>
	Quarterly	<p><b>Wicking Material:</b> Check that wicking material is still in good condition (hot gas condensate pans only).</p> <ul style="list-style-type: none"> <li>• Wicking material may be dirty or worn and need replacement.</li> <li>• Slide refrigeration system out from under unit.</li> <li>• Check whether wicking material is tattered, torn or disintegrating.</li> <li>• If wicking material is decomposing or is disrepair, replace with new. If wicking material is not available, contact Structural Concepts®. See toll-free number at last page of this operating manual.</li> </ul>

CONDITION	TROUBLESHOOTING
<b>Case Not Lining Up</b>	See Installation Section for instructions on properly aligning case (alongside other cases) and adjusting levelers.
<b>Water Is On The Floor</b>	<p><b>Caution!</b> Water on flooring can cause much damage! Until cause is determined (and repaired), following these procedures:</p> <ul style="list-style-type: none"> <li>• Use wet-dry vacuum (or mop &amp; bucket) to remove standing water.</li> <li>• Use 'catch pans' for water to drain into. Swap out regularly until case has completely drained.</li> </ul> <p><b>Note:</b> See <i>Drain, Hose and Bracket Placement Illustrations</i> sheet in this manual for views of different evaporator systems used in display cases.</p>
	Check that the drain trap is free of debris.
	Check that the drain hose is correctly positioned over evaporator pan (or floor drain, for remote units).
	Check store conditions. To prevent condensation in NSF® Type 1 environments, maximum conditions are to be 55% humidity / 75° Fahrenheit. For NSF® Type 2, maximum conditions are to be 60% humidity / 80° Fahrenheit. See serial label (at case rear near main power switch) for NSF® Type of your case.
	Check evaporator pan float for proper operation (Heat Rod Evaporator System only).
	Check that evaporator pan is properly plugged in or connected.
	<p><b>Caution!</b> Evaporator pan may be malfunctioning (Electrical Heat Rod Evaporator system). If so, water will overflow pan and seep onto flooring causing damage! Until evaporator pan is functioning (or is replaced), following these procedures:</p> <ul style="list-style-type: none"> <li>• Use wet-dry vacuum (or mop &amp; bucket) to remove standing water.</li> <li>• Use 'catch pans' for water to drain into. Swap out regularly until case has completely drained.</li> </ul>
	<p><b>Caution!</b> Disruption of power can cause water to overflow pan and seep onto flooring causing damage! Check that power to case is constant. Until power is restored, following these procedures:</p> <ul style="list-style-type: none"> <li>• Use wet-dry vacuum (or mop &amp; bucket) to remove standing water.</li> <li>• Use 'catch pans' for water to drainage. Swap out regularly until evaporation of case is complete (or until power is restored).</li> </ul> <p>When power to case is restored, evaporator pan should function properly and water will no longer overflow onto flooring.</p>
	<p><b>Caution!</b> Wicking material may be dirty, worn or disintegrating and need replacement (hot gas evaporator system only).</p> <ul style="list-style-type: none"> <li>• Slide refrigeration system out from under unit.</li> <li>• After refrigeration system has been carefully slid out from under unit, replace wicking material with new. If wicking material is not available, contact Structural Concepts®. See toll-free number at last page of this operating manual.</li> </ul>

CONDITION	TROUBLESHOOTING
<b>Fan Emits Excessive Noise</b>	Check that the case is aligned, level and plumb.
	Check evaporator fan for cleanliness.
	Unplug/power off fan motors. Check motor shaft for bearing wear.
	Check that fan motors are securely mounted in brackets.
	Verify that fan blades are securely mounted to fan motor.
	Check that nothing is preventing blade rotation.
	Check that the fan shroud is properly secured.
<b>Fans Are Not Working</b>	Check that the MAIN power switch is on.
	Check that fans are plugged in at the fan shroud.
	Check for foreign material obstructing fan performance.
	Check that fan blades freely rotate within fan shrouds
	Check that power is going to fans
	Check that fan wiring is connected on terminal blocks.
<b>Digital Control Display Is Blank</b>	Check that the MAIN power switch is on.
	Check the circuit breaker box for tripped circuits.
<b>System Not Operating</b>	Check that the utility power is on.
	Check that the MAIN power switch is on.
	Check the circuit breaker box for tripped circuits.

CONDITION	TROUBLESHOOTING
<b>Case Lights Are Not Working</b>	Check that light switch is in the <i>on</i> position.
	Check that <b>ALL</b> of the light cords and plugs are properly connected. See <b><i>MAINTENANCE - LIGHT FIXTURES (LED LIGHT FIXTURES)</i></b> section.
	Service Technicians Only: Check voltage at LED drivers. If voltage is entering but not exiting, LED driver may be faulty.
<b>Control Display Is Flashing</b>	See your case's serial label for your model's specified settings. See <b><i>SERIAL LABEL LOCATION &amp; INFORMATION LISTED / TECH INFO &amp; SERVICE</i></b> for label location, etc.
<b>Case Is Not Holding Temperature</b>	If a large amount of warm product was added to the case, it will take time for the temperature to adjust. Unit needs product to be pre-chilled.
	Temperature changes during defrost mode but will return to normal. Fourth LED will indicate defrost cycle in progress.
	Check that case is not in sun or near a heat or air-conditioning vent. See <b><i>OVERVIEW AND WARNINGS</i></b> section in manual for adverse conditions/spacing issue parameters.
	If case is located near front doors, temperature fluctuation can hinder unit's ability to maintain temperature. See <b><i>OVERVIEW AND WARNINGS</i></b> section in manual for adverse conditions/spacing issue parameters.
	Check that magnetic air filter (attached to rear grille) has been cleaned. See <b><i>GENERAL CLEANING (TO BE PERFORMED BY STORE PERSONNEL)</i></b> section in operating manual for instructions.
	Check that condenser coil has been cleaned.
	Check air return grilles for obstructions.
	Check sight glass for flashing and/or low charge.
	Check Set Point Temperature; it may be adjusted too high.
<b>Condensing Unit Is Not Operating</b>	Check that the power is turned on.
	Determine if temperature controller settings are properly set. See your case's serial label for your model's specified settings. See <b><i>SERIAL LABEL LOCATION &amp; INFORMATION LISTED / TECH INFO &amp; SERVICE</i></b> section in manual for label location, etc.

**TROUBLESHOOTING (BY TRAINED SERVICE PROVIDERS ONLY) - CONDENSING SYSTEM**

CONDITION	TROUBLESHOOTING
<b>Head Pressure Too High</b>	Check that the Condensing Coil is not dirty or covered.
	Check that Condensing Fans are working.
	Check that refrigerant is not overcharged.
	Check to verify that a non-condensable is not in the system.
	Check that Liquid Line Drier is not plugged.
	Check that there are no close-offs around Condensing Coil.
	Check Set Point Temp.; it may be adjusted too high.
	Check System Operating Temperatures.
	Check that Store Ambient Temperature isn't above maximum allowed. See <i>Overview and Warnings</i> Section.
<b>Head Pressure Too Low</b>	Check that Refrigerant Charge isn't too low.
	Check that Suction Pressure isn't too low.
	Check to verify that Compressor Valves aren't bad.

## TROUBLESHOOTING (BY TRAINED SERVICE PROVIDERS ONLY) - EVAPORATOR SYSTEM

CONDITION	TROUBLESHOOTING
<b>Low Suction Pressure</b>	Check that the Refrigerant doesn't have a low charge.
	Check that Expansion Valve (TXV Valve) isn't restricted.
	Check that Liquid Line or Filter isn't restricted.
	Check that Evaporator Motors are working.
	Check that High Superheat doesn't need adjusting.
	Check that the Thermostatic Element charge isn't depleted.
	Check that there is air no seepage of air around Condensing Coil.
	Check that the Coil is not iced up.
<b>High Suction Pressure</b>	Check that Refrigerant Charge isn't too high.
	Check that Compressor Valves aren't bad.
	Check that the Cooling Load isn't high.
	Check that Superheat Adjustment isn't low.
	Check TXV Bulb Installation a. Poor thermal contact. b. Warm location.
	Check Compressor: Low capacity means it is undersized for its application.

**PREVENTIVE MAINTENANCE (TO BE PERFORMED BY TRAINED SERVICE PROVIDER)**

**WARNING! TURN OFF CASE BEFORE PERFORMING PREVENTIVE MAINTENANCE!**

PREVENTIVE MAINTENANCE	FREQ.	INSTRUCTIONS
Case Exterior	Quarterly	<p><b><u>Condensing Coil:</u></b></p> <ul style="list-style-type: none"> <li>• Remove panel to access area by lifting up and off or by screw removal (depending on case).</li> <li>• Use air pressure or industrial strength vacuum; clean dust and dirt that may collect on the Condenser Coil.</li> <li>• <b>Caution! Airborne dust can contaminating food!</b> Use wet rags to cover area where air pressure is blowing.</li> <li>• <b>Warning! Coil fins are sharp. Handle with care!</b></li> <li>• Return panel to case.</li> </ul>
	Quarterly	<p><b><u>Refrigeration Package/Compressor Area:</u></b> <i>Caution! Be certain to disconnect power from case before cleaning Refrigeration Package!</i></p> <ul style="list-style-type: none"> <li>• <b>Warning! Evaporator Pan Is HOT! Disconnect power from case and allow to cool before cleaning evaporator pan!</b></li> <li>• Slide/Roll compressor package out from under case.</li> <li>• See <b>REFRIGERATION FUNDAMENTALS</b> section for in-depth instructions on accessing the evaporator pan.</li> <li>• Use a scrub-brush and a de-scaling solution such as CLR® (to prevent corrosion, lime and rust). Follow instructions as to proper dilution, safety precautions and scrubbing method.</li> <li>• Electric heater coil evaporator pans can be removed and cleaned.</li> <li>• After thoroughly cleaning pan with scrub-brush and solution, rinse thoroughly with clean water (in spray bottle) and wipe dry with sponge or paper towel.</li> <li>• Use moist cloth to wipe off dust &amp; debris that collects on various parts (fans, sight glass, overflow pan, etc.).</li> <li>• Slide refrigeration assembly back under case.</li> <li>• Replace front panel and lower grille via hooks (no screws required).</li> </ul>
	Quarterly	<p><b><u>Under Case Cleaning:</u></b> Once refrigeration package is clear of unit, vacuum under case to remove dust and dirt that may collect under case.</p>
Case Interior	Quarterly	<p><b><u>Tub Area (Evaporator Coil, Drain, Fans, Brackets):</u></b></p> <p><b>Caution! Disconnect power from the case before cleaning tub, coil, fan, motor and drain area!</b></p> <ul style="list-style-type: none"> <li>• Use vacuum to clean entire area.</li> <li>• After vacuuming, clean area with warm water, clean cloth, and mild soap solution.</li> <li>• Remove any debris that may clog drain.</li> <li>• Wipe down fan blades, motors and brackets with moist cloth.</li> </ul>
	Quarterly	<p><b><u>Honeycomb:</u></b> Check honeycomb air diffuser to determine if it is dirty. If dirty, remove from case. See <b>MAINTENANCE FUNDAMENTALS - HONEYCOMB AIR DIFFUSERS (SERVICE TECHNICIANS ONLY)</b> section of this manual (next page) for cleaning specifics.</p>

## PREVENTIVE MAINTENANCE OF HONEYCOMB AIR DIFFUSERS (SERVICE TECHNICIANS ONLY)

### Honeycomb Air Diffuser Removal

See **PREVENTIVE MAINTENANCE (TO BE PERFORMED BY TRAINED SERVICE PROVIDER)** section in this manual for cleaning frequency.

A. Wedge a non-metallic device of suitable strength (such as a ballpoint pen) between the honeycomb and the end panel.

*Caution! Use care not to dislodge the heating wire (that prevents condensation on the lamp assembly).*

B. Apply pressure to collapse the honeycomb to allow it to be pulled out of honeycomb retainer.

C. Carefully pry downward and away from the honeycomb retainer.

Clean honeycomb with warm water and soap solution. Submerge if necessary. Use brush to dislodge stubborn or sticky residue. Dry by using vacuum's blow mode (vs. suction mode).

### Honeycomb Air Diffuser Installation

D. Squeeze honeycomb to allow it to fit into the honeycomb retainer.

E. Carefully slide honeycomb into place.

F. Adjust honeycomb so that it fits flat against retainer. It must not be wavy or out of position.

*Note: For honeycomb air diffusers in other locations, these same general instructions apply.*

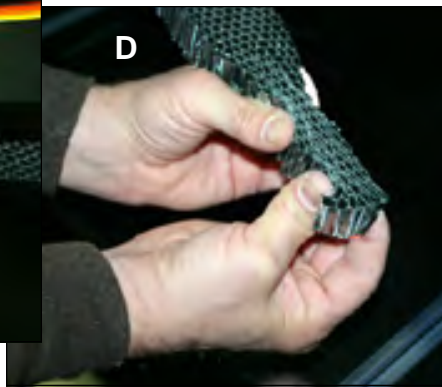

View of Honeycomb Air Diffuser (Typical on All Cases)

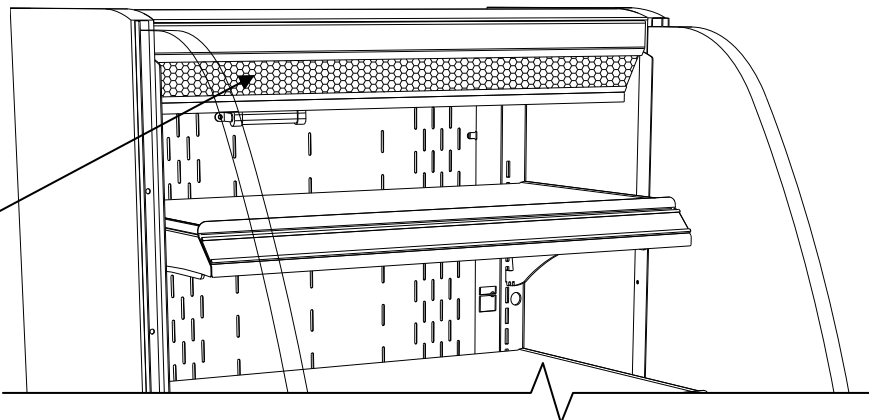

**Serial Label Location & Information Listed / Technical Information & Service**

- Serial labels are located near the electrical access on your case.
- Serial labels contain electrical, temperature & refrigeration information, as well as regulatory standards to which the case conforms.
- For additional technical information and service, see the *TECHNICAL SERVICE* page in this manual for instructions on contacting Structural Concepts' Technical Service Department.
- See images below for samples of both refrigerated and non-refrigerated serial labels.



888 E. Porter Rd · Muskegon, MI 49441

**ENCORE<sup>®</sup>** MODEL HV74RSS SCROLL  
SERIES SERIAL NO.

**FOR PARTS AND SERVICE**  
CALL 1-800-433-9489



3048256  
CONFORMS TO UL STD 471  
CONFORMS TO NSF STD 7  
CERTIFIED TO CAN/CSA  
STD C22.2 NO 120

ELECTRICAL RATING	120/1/60 24A
REFRIGERANT	R404A AMOUNT ?? OZ
DESIGN PRESSURE	HIGH 450 LOW 200
MINIMUM CIRCUIT	30A
MAXIMUM OVERCURRENT	30A

**SAMPLE ONLY**

**SAMPLE ONLY**

**SAMPLE ONLY**

Super Heat Temp	8-10°F
BTUH Requirements	9,738 BTUH @ 20° F SST
Defrost	6 defrosts per day, 45° F termination, 45 min. failsafe

----- Sample Serial Label For Refrigerated Case -----



888 E. Porter Rd · Muskegon, MI 49441

**Addenda<sup>®</sup>** PC5682 txtRemote  
txtSerialNumber

120 VOLTS 60 HZ SINGLE PHASE 1.84AMP

**FOR PARTS OR SERVICE CALL**  
**STRUCTURAL CONCEPTS**  
AT  
1-800-433-9489



3048256  
CONFORMS TO UL STD 65  
CERTIFIED TO CAN/CSA  
STD C22.2 NO 120

**SAMPLE ONLY**

----- Sample Serial Label For Non-Refrigerated Case -----

# CAREL

## ir33 platform

Integrated Electronic  
Microprocessor Controller



### Programming The Instrument

#### To Modify The Setpoint

**Set** Press and hold the "SET" key for at least 1 second.

**▲/aux** **def/▼** 2. Use arrow keys ▲ ▼ on temperature controller to increase (or decrease) the setpoint.

**Set** 3. Quickly press and release the "SET" key again.

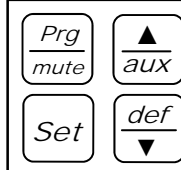

#### To Modify Defrost, Differential, Other Parameters

**Prg/mute** **Set** 1. Press & hold "Prg" & "SET" keys together for five (5) seconds; display will flash "0", representing password prompt.

**Set** 2. Confirm by pressing "SET" key.

**▲/aux** **def/▼** 3. Press ▲ or ▼ to reach the category to be modified.

**Set** 4. Press "SET" to modify this selected parameter.

**▲/aux** **def/▼** 5. Increase or decrease the value using the ▲ or ▼ button respectively.

**Set** 6. Press the "SET" key to temporarily save the new value and return to the display of the parameter.

**Prg/mute** 7. Press & hold the "Prg" key for at least 5 seconds to save changes. This action will also mute the audible alarm (buzzer) & deactivate the alarm relay.

#### How To Change Reading From Fahrenheit (°F) To Celsius (°C)

**Prg/mute** **Set** 1. Press and hold "Prg" and "SET" keys together for at least 5 seconds; display will show "0" (password prompt).

**Set** 2. Confirm by pressing "SET" key.

**▲/aux** **def/▼** 3. Press ▲ or ▼ until reaching the parameter "/ 5".

**Set** 4. Press "SET" to modify this selected parameter.

**▲/aux** **def/▼** 5. Press ▲ or ▼ to change value to desired setting: "0" for Celsius (°C) or "1" for Fahrenheit (°F).

**Set** 6. Press "SET" key to temporarily save the new value and return to the display of the parameter.

**Prg/mute** 7. Press & hold "Prg" key for at least 5 seconds to save changes. **Note! All values will automatically convert to new scale. No conversion is required.**

#### Warning! Save Your Parameter Settings!

1. To store the new parameter values, PRESS and HOLD the "Prg" key for at least 5 seconds.
2. All modifications made to parameters will be lost if you do NOT press a button within 60 seconds. Should this "timeout" occur, normal operational settings (prior to modifications being made) will resume.
3. If the instrument is switched off before pressing the "Prg" key, all modifications to parameters will be lost.

**def/▼** **To Activate Manual Defrost**  
Press and hold "def" key for at least 5 seconds.

**▲/aux** **To Activate / Deactivate Auxiliary Output**  
Press and hold the "aux" key for 1 second.

**Prg/mute** **▲/aux** **To Reset Any Alarms With Manual Reset**  
Press and hold the "Prg" and "aux" key for at least 1 second.

# CAREL

**ir33 platform**  
**Integrated Electronic  
 Microprocessor Controller**



## User Interface - Display

ICON	FUNCTION	DESCRIPTION	Normal operation			Start up
			ON	OFF	BLINK	
	COMPRESSOR	ON when the compressor starts. Flashes when the activation of the compressor is delayed by safety times.	Compressor on	Compressor off	awaiting activation	
	FAN	ON when the fan starts. Flashes when the activation of the fan is prevented due to external disabling or procedures in progress.	Fan on	Fan off	awaiting activation	
	DEFROST	ON when the defrost is activated. Flashes when the activation of the defrost is prevented due to external disabling or procedures in progress.	Defrost in progress	Defrost not in progress	awaiting activation	
	AUX	Flashes if the anti-sweat heater function is active, ON when the auxiliary output (1 and/or 2) selected as AUX (or LIGHT in firmware version 3.6) is activated.	AUX auxiliary output active (version 3.6 light auxiliary output active)	AUX auxiliary output not active	Anti-sweat heater function active	
	ALARM	ON following pre-activation of the delayed external digital input alarm. Flashes in the event of alarms during normal operation (e.g. high/low temperature) or in the event of alarms from an immediate or delayed external digital input.	Delayed external alarm (before the time 'A7' elapses)	No alarm present	Alarms in norm. operation (e.g. High/low temperature) or immediate or delayed alarm from external digital input	
	CLOCK	ON if at least one timed defrost has been set. At start-up, comes ON for a few seconds to indicate that the Real Time Clock is fitted.	If at least 1 timed defrost event has been set	No timed defrost event set	Alarm clock	ON if real-time clock present
	LIGHT	Flashes if the anti-sweat heater function is active, ON when the auxiliary output (1 and/or 2) selected as LIGHT is activated (in firmware version 3.6 it does not flash in anti-sweat heater mode and comes on when the dead band output is active).	Light auxiliary output on (version 3.6 dead band auxiliary output active)	Light auxiliary output off	Anti-sweat heater function active (version 3.6 does not flash in anti-sweat heater mode)	
	SERVICE	Flashes in the event of malfunctions, for example E2PROM errors or probe faults.		No malfunction	Malfunction (e.g. E2PROM error or probe fault). Contact service	
	CONTINUOUS CYCLE	ON when the CONTINUOUS CYCLE function is activated. Flashes if the activation of the function is prevented due to external disabling or procedures in progress (E.g.: minimum compressor OFF time).	CONTINUOUS CYCLE operation activated	CONTINUOUS CYCLE function not activated	CONTINUOUS CYCLE operation requested	

## Summary Table of Alarm and Signals: Display, Buzzer and Relay

Code	Icon on the display	Alarm relay	Buzzer	Reset	Description
rE	flashing	on	on	automatic	virtual control probe fault
E0	flashing	off	off	automatic	room probe S1 fault
E1	flashing	off	off	automatic	defrost probe S2 fault
E2	flashing	off	off	automatic	probe S3 fault
E3	flashing	off	off	automatic	probe S4 fault
E4	flashing	off	off	automatic	probe S5 fault
	No	off	off	automatic	probe not enabled
LO	flashing	on	on	automatic	low temperature alarm
HI	flashing	on	on	automatic	high temperature alarm
AFr	flashing	on	on	manual	antifreeze alarm
IA	flashing	on	on	automatic	immediate alarm from external contact
dA	flashing	on	on	automatic	delayed alarm from external contact
dEF	on	off	off	automatic	defrost running
Ed1	No	off	off	automatic/manual	defrost on evaporator 1 ended by timeout
Ed2	No	off	off	automatic/manual	defrost on evaporator 2 ended by timeout
Pd	flashing	on	on	automatic/manual	maximum pump down time alarm
LP	flashing	on	on	automatic/manual	low pressure alarm
AtS	flashing	on	on	automatic/manual	autostart in pump down
cht	No	off	off	automatic/manual	high condenser temperature pre-alarm
CHT	flashing	on	on	manual	high condenser temperature alarm
dor	flashing	on	on	automatic	door open too long alarm
EE	flashing	off	off	automatic	E2prom error, unit parameters
EF	flashing	off	off	automatic	E2prom error, operating parameters
ccb	Signal				start continuous cycle request
ccE	Signal				end continuous cycle request
dFb	Signal				start defrost call
dFE	Signal				end defrost call
On	Signal				switch ON
off	Signal				switch OFF
rES	Signal				reset alarms w/manual reset / reset HACCP alarms / reset temp. monitoring

# CAREL

## ir33 platform

Integrated Electronic  
Microprocessor Controller



### Summary Table of Operating Parameters

CODE	PARAMETER	UOM*	TYPE	MINIMUM	MAXIMUM	DEFAULT
/5	Select Celsius (°C) or Fahrenheit (°F)	flag	C	0	1	For Case Specific Defaults See Serial Label Located Near Electrical Access On Your Case.  For Additional Technical Information Call Structural Concepts Technical Service Dept. at 1(800) 433.9489
/c1	Calibration of probe 1	°C/°F	C	-20	20	
/c2	Calibration of probe 2	°C/°F	C	-20	20	
St	Temperature set point	°C/°F	F	r2	r1	
rd	Control delta	°C/°F	F	20	0.1	
dl	Interval between defrosts	hours	F	0	250	
dt1	End defrost temperature, evaporator	°C/°F	F	-50	200	
dP1	Maximum defrost duration, evaporator	min	F	1	250	
d6	Display on hold during defrost	-	C	0	2	
dd	Dripping time after defrost	min	F	0	15	
d/1	Display of defrost probe 1	°C/°F	F	-	-	

\* Unit Of Measure

STRUCTURAL CONCEPTS CORPORATION TECHNICAL SERVICE  
PHONE NUMBER: 1.800.433.9489 or For Your Master Service Agent See  
WWW.STRUCTURALCONCEPTS.COM/Contact/Master\_Service\_Agents.asp

# LIMITED WARRANTY

All sales by Structural Concepts Corporation (SCC) are subject to the following limited warranty. "Goods" refers to the product or products being sold by SCC.

**Warranty Scope:** Warranty is for equipment sold in the United States, Canada, Mexico and Puerto Rico. Equipment sold elsewhere may carry modified warranty.

**Warranty; Remedies; Limitations.** SCC warrants that if any Goods are found by an authorized representative of SCC not to be of good material or workmanship within one year of the date of shipments SCC will, at its option after inspection by an authorized representative, replace any defective Good or pay the reasonable cost of replacement for any such defective Goods, provided that written notice of the defect is given to SCC within 30 days of the appearance of such defect. If notice is not given within such period, any claim for breach of warranty shall be conclusively deemed to have been waived and SCC shall not be liable under this warranty. If SCC is unable to repair or replace the defective Goods, SCC shall issue a credit to the Purchaser for all or part of the purchase price, as SCC shall determine. The replacement or payment in the manner described above shall be the sole and exclusive remedy of Purchaser for a breach of this warranty. If any Goods are defective or fail to conform to this warranty, SCC will furnish instructions for their disposition. No Goods shall be returned to SCC without its prior consent.

SCC's liability for any defect in the Goods shall not exceed the purchase price of the Goods. SCC SHALL HAVE NO LIABILITY TO PURCHASE FOR CONSEQUENTIAL DAMAGES OF ANY KIND WHATSOEVER, INCLUDING, BUT NOT LIMITED TO, PERSONAL INJURY, PROPERTY DAMAGE, LOST PROFITS, OR OTHER ECONOMIC INJURY DUE TO ANY DEFECT IN THE GOODS OR ANY BREACH OF SCC, SCC SHALL NOT BE LIABLE TO THE PURCHASER IN TORT FOR ANY NEGLIGENT DESIGN OR MANUFACTURE OF THE GOODS, OR FOR THE OMISSION OF ANY WARNING THEREFROM.

SCC shall have no obligation or liability under this warranty for claims arising from any other party's (including Purchaser's) negligence or misuse of the Goods or environmental conditions. This warranty does not apply to any claim or damage arising for or cause by improper storage, handling, installation, maintenance, or from fire, flood, accidents, structural defects, building settlement or movement, acts of God, or other causes beyond SCC's control.

Except as expressly stated herein, SCC makes no warranty, express, implied, statutory or otherwise as to any parts or goods not manufactured by SCC. SCC shall warrant such parts or Goods only (I) against such defects, (II) for such periods of time, and (III) with such remedies, as are expressly warranted by the manufacturer of such parts of Goods. Notwithstanding the foregoing, any warranty with respect to such parts of Goods and any remedies available as a result of a breach thereof shall be subject to all of the procedures, limitations, and exclusions set forth herein.

THE WARRANTIES HEREIN ARE IN LIEU OF ALL WARRANTIES, EXPRESS, IMPLIED, STATUTORY, OR OTHERWISE. IN PARTICULAR, SCC MAKES NO WARRANTY OF MERCHANTABILITY OR FITNESS FOR A PARTICULAR PURPOSE.

No representative, agent or dealer of SCC has authority to modify, expand, or extend this Warranty, to waive any of the limitations or exclusions, or to make any different or additional warranties with respect to Goods.

**Period of Limitations.** No claim, suit or other proceeding may be brought by Purchaser for any breach of the foregoing warranty or this Agreement by SCC or in any way arising out of this Agreement or relating to the Goods after one year from the date of the breach. In the interpretation of this limitation on action for a breach by SCC, it is expressly agreed that there are no warranties of future performance of the goods that would extend that period of limitation herein contained for bringing an action.

**Indemnifications.** Purchaser agrees to indemnify, hold harmless, and defend SCC if so requested, from any and all liabilities, as defined herein, suffered, or incurred by SCC as a result of, or in connection with, any act, omission, or use of the Goods by Purchaser, its employees or customers, or any breach of this Agreement by Purchaser. Liabilities shall include all costs, claims, damages, judgments, and expenses (including reasonable attorney fees and costs).

**Remedies of SCC.** SCC's rights and remedies shall be cumulative and may be exercised from time to time. In a proceeding or action relating to the breach of this Agreement by Purchaser, Purchaser shall reimburse SCC for reasonable costs and attorney's fees incurred by SCC. No waiver by SCC of any breach of Purchaser shall be effective unless in writing nor operate as a waiver of any other breach of the same term thereafter. SCC shall not lose any right because it has not exercised it in the past.

**Applicable Law.** This Agreement is made in Michigan and shall be governed by and interpreted according to Michigan law. Any lawsuit arising out of this Agreement or the Goods may be handled by a federal or state court whose district includes Muskegon County, Michigan, and Purchaser consents that such court shall have personal jurisdiction over Purchaser.

**Miscellaneous.** If any provision of this Agreement is found to be invalid or unenforceable under any law, the provision shall be ineffective to that extent and for the duration of the illegality, but the remaining provisions shall be unaffected. Purchaser shall not assign any of its rights nor delegate any of its obligations under this Agreement without prior written consent of SCC. This Agreement shall be binding upon and inure to the benefit of SCC and Purchaser and each of their legal representatives, successors and assigns.

SCC warrants its products to be free of defects in materials and workmanship under normal use and service for a period of one (1) year from the date of delivery.

This warranty is extended only to the original purchaser for use of the Goods. It does not cover normal wear parts such as plastic tongs, tong holders, tong cables, bag holders, or acrylic dividers.

**General Conditions.** All service labor and/or parts charges are subject to approval by SCC. Contact the Customer Service Department in writing or call 231-798-8888.

All claims must contain the following information: (1) model & serial code number of equipment; (2) the date and place of installation; (3) the name and address of the agency which performed the installation; (4) the date of the equipment failure; and (5) a complete description of the equipment failure and all circumstances relating to that failure.

Once the claim has been determined to be a true warranty claim by SCC's Customer Service Department, the following procedure will be taken: (1) replacement parts will be sent at no charge from SCC on a freight prepaid basis; (2) reimbursement for service labor will be paid if the following conditions have been met - (a) prior approval of service agency was awarded from the Customer Service Department; and (b) an itemized statement of all labor charges incurred is received by the Customer Service Department. The cost of the service labor reimbursement will be based on straight time rates and reasonable time for the repair of the defect.

If problems occur with any compressor, notify SCC's Customer Service Department immediately. Any attempt to repair or alter the unit without prior consent from the Customer Service Department will render any warranty claim null and void. This warranty and protection plan does not apply to any condensing unit or any part thereof which has been subject to accident, negligence, misuse, or abuse, or which has not been operated in accordance with the manufacturer's recommendations or if the serial number of the unit has been altered, defaced, or removed.

**Limit of Liability.** The limit of liability of SCC toward the exchange cost of the original condensing unit, F.O.B. SCC, Norton Shores, MI, of each motor-compressor assembly replaced during the warranty shall not exceed manufacturer's current established wholesaler's exchange price and in no case shall the labor of removing or replacing the motor-compressor or parts thereof be the responsibility of SCC.