

G-SERIES INSTALLATION AND OPERATING MANUAL

**PART NO.
20-17016**

COMBINATION COLD MERCHANDISERS: SERVICE UPPER / SELF SERVICE LOWER "TALL DOMES"

>> BLOWER COIL UNITS (STANDARD) >> GRAVITY COIL UNITS (OPTIONAL) >> THREE (3) UPPER SECTION VARIABLES:

- ◆ **DELI PRODUCTS:** BLOWER COILS (NO GRAVITY COILS NOR ICE TRAYS)
- ◆ **MEAT PRODUCTS:** GRAVITY COILS WITH PLATTER COILS (NO BLOWER COILS)
- ◆ **SEAFOOD PRODUCTS:** GRAVITY COILS WITH ICE TRAYS (NO BLOWER COILS)

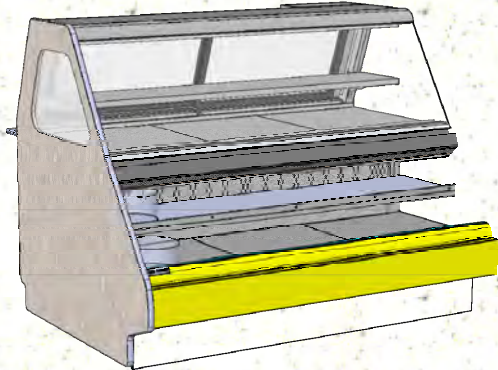

MODEL GCDT656RLB
(LOWER BASE UNIT)
WITH FLAT GLASS

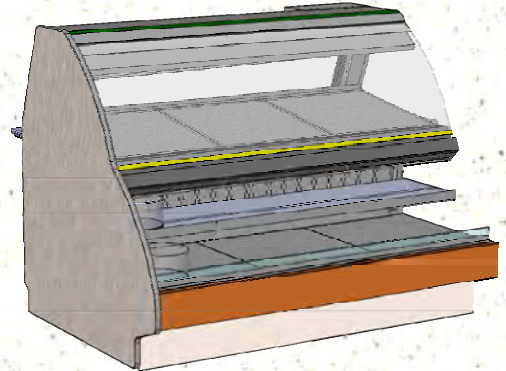

MODEL GCDT656RLB
(LOWER BASE UNIT)
WITH CURVED GLASS

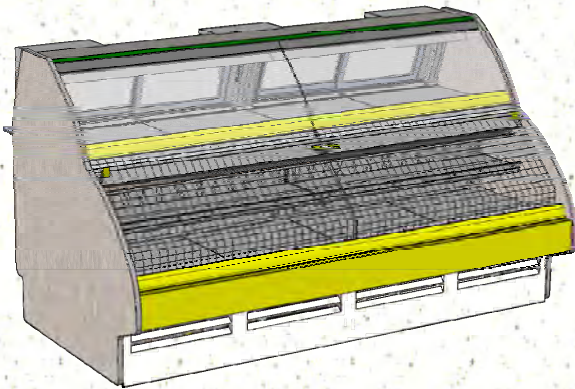

MODEL GCD856R (SHOWN W/OPTIONAL SECURITY GRID)

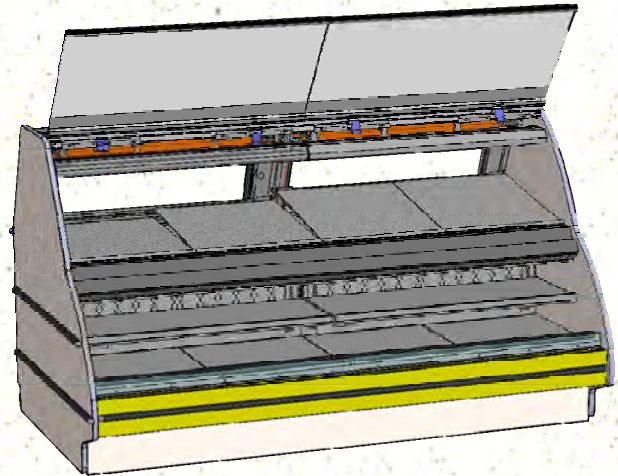

MODEL GCDT856RLB (LOWER BASE UNIT WITH ANGLED GLASS).
NOTE: GLASS RAISED FOR ILLUSTRATIVE PURPOSES ONLY

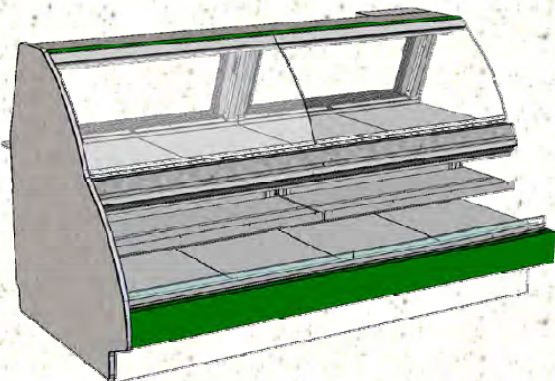

MODEL GCDT856RLB (LOWER BASE
UNIT WITH CURVED GLASS)

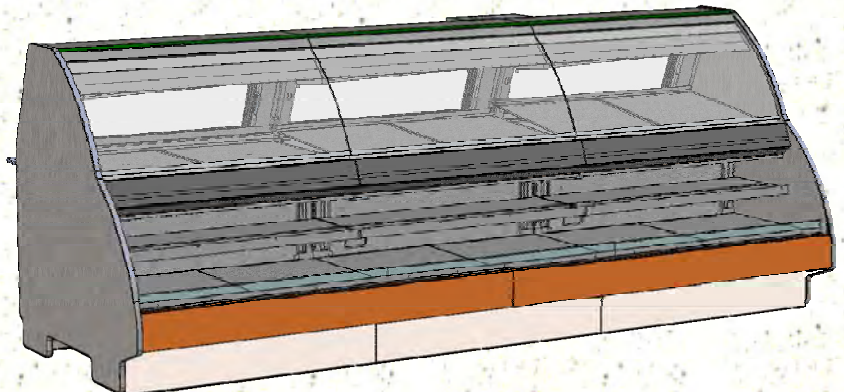

MODEL GCDT1256RLB (LOWER BASE UNIT)

Models Included in Operating Manual
 GCD456R, GCDT456RLB, GCD656R, GCDT656RLB,
 GCD856R, GCDT856RLB, GCD1256R, GCDT1256RLB



TABLE OF CONTENTS / MODEL LENGTH, DEPTH & HEIGHT

TABLE OF CONTENTS	2
OVERVIEW / TYPE / COMPLIANCE / WARNINGS / PRECAUTIONS / WIRING DIAGRAM / PLUGS	3-4
INSTALLATION: REMOVAL FROM SKID, REMOVING VERTICAL LOWER FRONT PANEL	5
INSTALLATION: POSITIONING & ALIGNING CASE / BOLTING & CAULKING UNITS TOGETHER ...	6
INSTALLATION: FRAME SUPPORT RAIL SHIMMING	7
INSTALLATION, CONT.: ADJUSTING LEVELERS	8
INSTALLATION: TEMPERATURE & DEFROST CONTROL / REAR PANEL REMOVAL / THERMOMETERS	9
STORE PERSONNEL SECTION ONLY	10
OPERATION: DRIVERS / BALLASTS / T'BLOCK / CONTACTOR, ETC., GENERAL LAYOUT	11
OPERATION: MAIN PWR SWITCH / THERMOSTAT (S.C. UNITS ONLY) / SCALE STAND	12
OPERATION: BLOWER COIL UNIT (DELI CASE) REFRIG. LINES / DRAINS / TXV, ETC.....	13-14
OPERATION: PLATTER COIL / GRAVITY COIL (MEAT CASE): REFRIG. LINES / DRAINS / TXV.....	15-16
OPERATION: GRAVITY COIL / ICE TRAYS (SEAFOOD CASE): REFRIG. LINES / DRAINS / TXV	17
OPERATION: (MODEL GCDT1256RLB GRAVITY COIL UNIT) DRAIN CONNECTIONS / AXIAL FANS	18
OPERATION: GRAVITY COIL UNITS - ADJUSTABLE DECKING (4° AND 8° ANGLES) / HUMIDICATION FEATURE (MISTING/FOGGING DEVICE)	19
OPERATION: DISPLAY CASE START-UP / LIGHT SWITCHES / REAR STORAGE & SHELVING	20
OPERATION: DISPLAY CASE START-UP, LIGHTS, TEMPERATURE CONTROLLER, SST	21
STOCKING / MAINTAINING PROPER PRODUCT CONDITION / IMPORTANT PROCEDURES	22
MAINTENANCE: REAR SLIDING DOORS / STANDARD LIGHT FIXTURES	23
MAINTENANCE: BRACKET RETAINERS / SHELVES / LOAD LIMITS	24
MAINTENANCE: PRODUCT PLACEMENT / PAN PLACEMENT (MEAT CASE)	25
MAINTENANCE: CUTTING BOARD/REAR LEDGE LOWERING	26
CLEANING SCHEDULE (INTERIOR) - TO BE PERFORMED BY STORE PERSONNEL.....	27
CLEANING SCHEDULE (EXTERIOR) - TO BE PERFORMED BY STORE PERSONNEL.....	28
TROUBLESHOOTING - TO BE PERFORMED BY STORE PERSONNEL	29
TRAINED SERVICE PROVIDERS SECTION ONLY	30
REFRIGERATION PACKAGE LAYOUT: MODEL GCD456R SELF-CONTAINED UNIT	31
REFRIGERATION PACKAGE LAYOUT, CONT.: MODEL GCD856R SELF-CONTAINED UNIT	32
CLEANING SCHEDULE (INTERIOR) - TO BE PERFORMED BY TRAINED SERVICE PROVIDERS ..	33-34
TROUBLESHOOTING - TO BE PERFORMED BY TRAINED SERVICE PROVIDERS ONLY	35-37
PREVENTIVE MAINTENANCE - TO BE PERFORMED BY TRAINED SERVICE PROVIDERS ONLY ..	38
MAINTENANCE - FRONT GLASS ALIGNMENT & ADJUSTMENT VIA CLAMSHELL SCREWS	39
MAINTENANCE, CONT. - FRONT GLASS ALIGNMENT VIA FRAME SUPPORT RAILS	40
MAINTENANCE, CONT. - FRONT GLASS ALIGNMENT VIA LEVELERS	41-42
GENERAL TECHNICAL INFORMATION (PARTS LIST / SERIAL LABEL INFO / TEMPERATURE CONTROLLER INFORMATION / TECHNICAL SERVICE INFORMATION, ETC.)	43
SERIAL LABEL INFORMATION & LOCATION	44
CAREL TEMPERATURE CONTROLLER (THERMOSTAT) INFORMATION	45-47
TECHNICAL SERVICE CONTACT INFORMATION & WARRANTY INFORMATION	48

OVERVIEW

- **Upper Section:** This merchandiser is designed to merchandise unpackaged product at a range of 33 °F to 38 °F (1 °C to 3 °C) product temperatures.
- **Lower Section:** This merchandiser is designed to merchandise packaged product at 41 °F (5 °C) or less product temperatures.
- **Product Pre-Chill Requirement:** Product must be pre-chilled to above listed temperatures prior to being placed in merchandiser.
- These cases should be installed and operated according to this operating manual's instructions to ensure proper performance. Improper use will void warranty.
- Improper use will void warranty.

TYPE 1 vs. TYPE 2 CONDITIONS

This unit is designed for the display of products in ambient store conditions where temperatures and humidity are maintained within a specific range.

- For Type 1 Conditions (most cases): ambient conditions are to be at 55% maximum humidity and maximum temperatures of 75 °F (24 °C).

- For Type 2 Conditions: ambient conditions are to be at 60% maximum humidity and maximum temperatures of 80 °F (27 °C).
- If unsure if unit is designed for Type 1 or 2, see tag next to serial label. See **SERIAL LABEL LOCATION & INFORMATION LISTED / TECH INFO & SERVICE** section in this manual for sample serial labels.

COMPLIANCE

- Performance issues when in violation of applicable NEC, federal, state and local electrical and plumbing codes are not covered by warranty.
- See below compliance guideline.

WARNINGS

- This sheet contains important warnings to prevent injury or death.
- Please read carefully!

PRECAUTIONS, CORD/PLUG MAINTENANCE & WIRING DIAGRAM INFORMATION

- See next page for **PRECAUTIONS, CORD/PLUG MAINTENANCE** and **WIRING DIAGRAM** information.



**ATTENTION
INSTALLER**

COMPLIANCE
This equipment **MUST** be installed in compliance with all applicable NEC, federal, state and local electrical and plumbing codes.

WARNING

**ELECTRICAL
HAZARD**



WARNING
Risk of electric shock. Disconnect power before servicing unit. **CAUTION!** More than one source of electrical supply is employed with units that have separate circuits. **Disconnect ALL ELECTRICAL SOURCES before servicing.**

WARNING

**KEEP
HANDS
CLEAR**



WARNING
Hazardous moving parts. Do not operate unit with covers removed. Fan blades may be exposed when deck panel is removed. Disconnect power before removing deck panel.

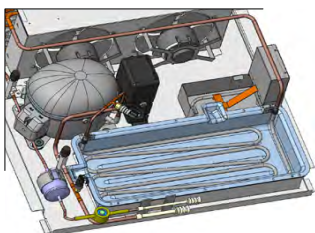

CAUTION! CHECK BOTH CONDENSATE PAN AND OVERFLOW PAN
Water on floor can cause extensive damage! Before powering up unit:

- Condensate pan **MUST BE** positioned directly under condensate drain.
- Overflow pan **MUST HAVE** single plug connected to its box. Units with optional Clean Sweep™ **MUST HAVE** two plugs connected.

PRECAUTIONS

- This sheet contains important precautions to prevent damage to unit or merchandise.
- Please read carefully!
- See previous page for specifics on **OVERVIEW**, **CONDITION TYPE**, **COMPLIANCE** and **WARNINGS**.

- Wiring diagram placement may vary; it may be placed near ballast box, field wiring box, raceway cover, or other related location.

POWER CORD AND PLUG MAINTENANCE

- Caution! Risk of electric shock.
- If cord or plug becomes damaged, replace only with cord and plug of same type.

WIRING DIAGRAM

- Wiring diagram is folded and in its own packet.



CAUTION! LAMP REPLACEMENT GUIDELINES
 Fluorescent lamps have been treated to resist breakage and must be replaced with similarly treated lamps.



CAUTION! GFCI BREAKER USE REQUIREMENT
 If N.E.C. (National Electric Code) or your local code requires GFCI (Ground Fault Circuit Interrupter) protection, you **MUST** use a GFCI breaker in lieu of a GFCI receptacle.



CAUTION! POWER CORD AND PLUG MAINTENANCE
 Risk of electric shock. If cord or plug becomes damaged, replace only with cord and plug of same type.

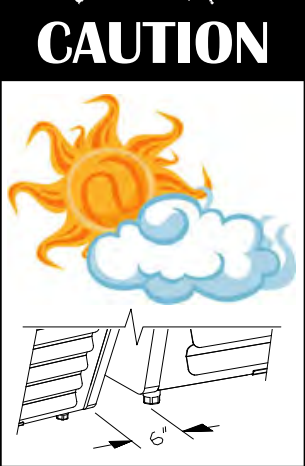

CAUTION! ADVERSE CONDITIONS / SPACING ISSUES

- Performance issues caused by adverse conditions are **NOT** warranted.
- End panels must be tightly joined or kept at least **6-inches** away from any structure to prevent condensation.
- Unit must be kept at least **15-feet** from exterior doors, overhead HVAC vents or any air curtain disruption to maintain proper temperatures.
- Unit must not be exposed to direct sunlight or any heat source (ovens, fryers, etc.).
- Tile floors/low ceilings/small rooms increase noise level. Whisper Cool compressor blanket or remote unit may resolve noise level issues.
- Keep at least **8-inch** clearance above unit for air discharge (self-contained units only).

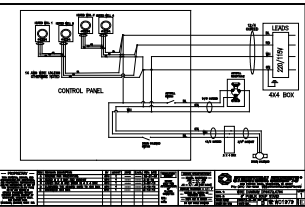

WIRING DIAGRAM FORMAT & LOCATION

- Each case has its own wiring diagram folded & in its own packet.
- Wiring diagram placement may vary; it may be placed near ballast box, field wiring box, raceway cover, or other related location.

INSTALLATION: REMOVAL FROM SKID, REMOVING VERTICAL LOWER FRONT PANEL

1. Remove Case From Skid (Rails)

- Remove shipping brace that may be securing case to skid.
- Support case to prevent tipping.
- **Caution! Levelers can be damaged if case hits floor with heavy force!**
- Carefully slide unit to rear of skid and tip backward off skid.
- Illustration may not reflect every feature or option of your particular case.

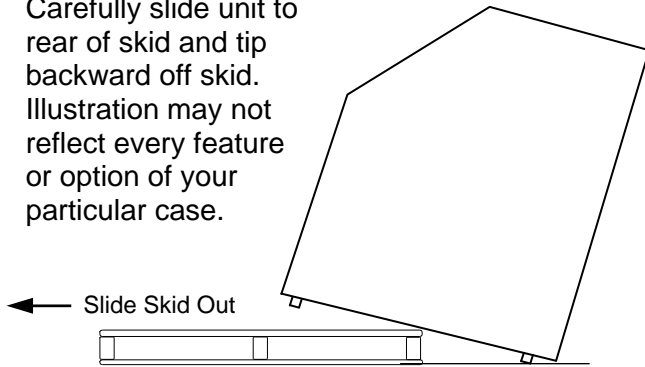

Case can be repositioned with pallet truck when front lower panel is removed. Blocking may be necessary to obtain adequate height.

2. Remove Case From Skid (Casters)

Remove shipping brackets that may be securing casters to skid

- Place ramp up against skid (to allow case to smoothly slide off from skid).
- Maintain support of case at all times or center of gravity may cause case to fall.
- Unlock Casters. Roll unit to rear of skid.
- Roll down ramp and off from skid.

Note: Illustrations shown reflect a general outline of sample cases and do not reflect features or options of your particular model.

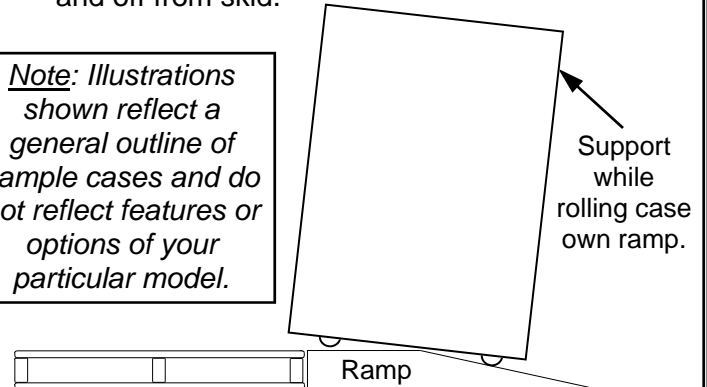

3. Removing Vertical Lower Front Panel

Removing Lower Front Panel

- No screw removal is required to remove lower front panel.
- Simply lift lower front panel slots up and off case hooks.
- Replace in same manner it was removed.

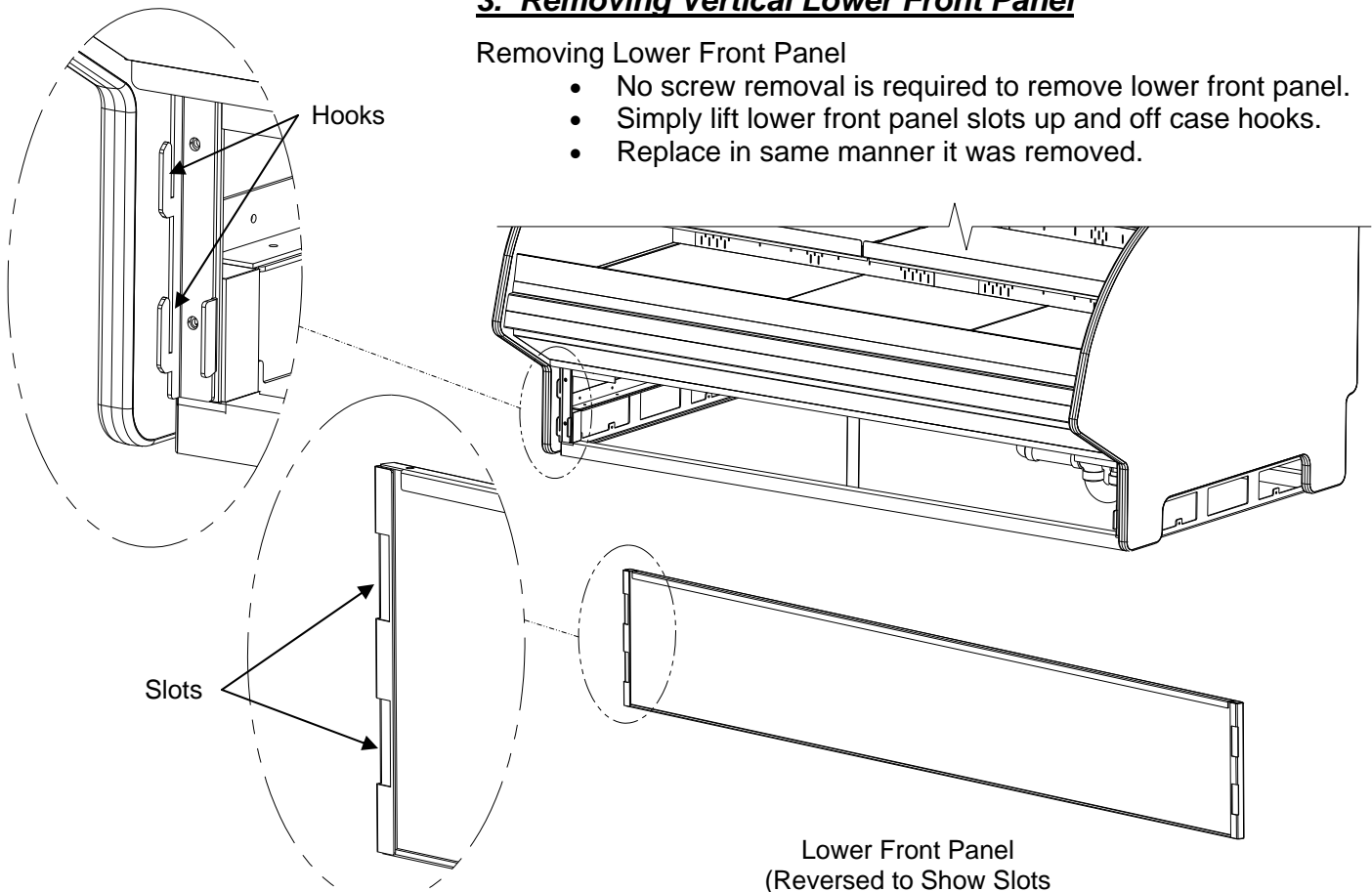

4. Position & Align Case Alongside Other Cases

- Before adjusting levelers (or shimming frame support rails), make certain that case is in proper position and, if required, aligned with adjoining case.
- This may require the repositioning of the case you are installing or the already positioned case.

5. Bolting and Caulking Units Together

Follow these steps to assure a secure, level lineup.

- Begin lineup leveling from highest point of floor.
- After 'first' case is level, apply industrial grade butyl caulk on non-visible areas (at case end). Use industrial grade silicone sealant on visible areas (at case end). See caulk/silicone illustrations at lower-left.
- Form Two (2) Caulk/Sealant Lines:** (Sanitation and Refrigeration). See illustration at mid-right for outline of caulk/sealant lines.
- Line up 'second' case bolt-hole to bolt-hole to 'first' case.
- Using SCC-supplied bolts (and/or screws) found in installation packet, insert bolts in bolt hole locations (shown below). You may need to remove decking to access lower bolt holes.
- Caution! Front of cases MUST be flush with each other! After leveling, cases are to be same height.
- Using SCC-supplied nuts & bolts, **lightly tighten** each of the 5 to 8 bolts in a cross-wise pattern. Work your way around the pattern, tightening more firmly at each pass. **Do not** firmly tighten one bolt and then start on the next!
- After the cases are bolted together, level the 'second' case. Repeat this process for each case to be adjoined.
- After all lined-up cases are level, seal all seams with industrial grade silicone sealant.

Sanitation Bead



Refrigeration Bead



Approximate hole locations pointed at with arrows (←) for bolting units together.

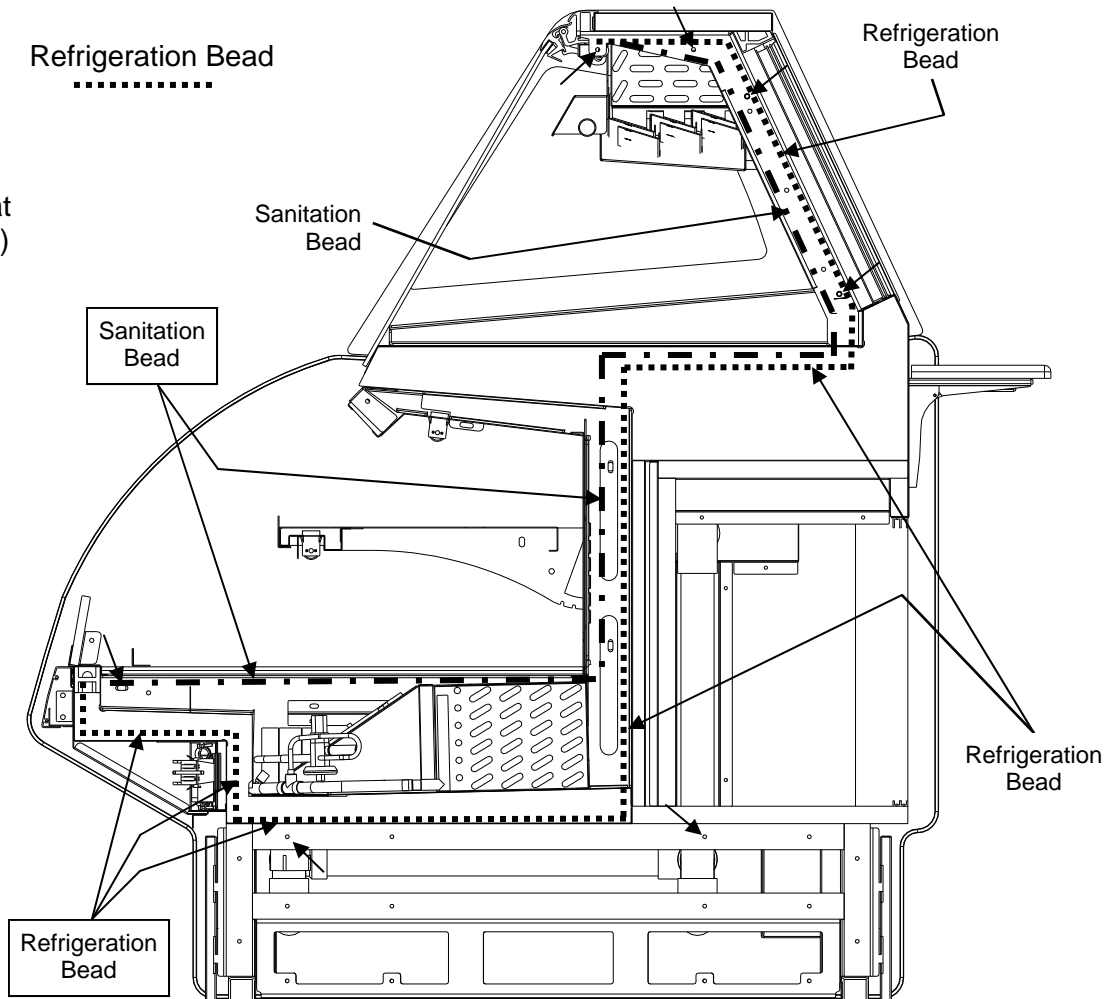

Butyl is to be used on non-visible areas.
Silicone is to be used on visible areas.

6. Frame Support Rails Must Be Shimmed

- Illustration below shows case with frame support rails.
- Shims will be provided with all cases that have frame support rails.
- Use shims to level case.
- **Note:** After case is in position, it must be sealed to floor to prevent entry or leakage of liquid or moisture.
- Caution: If glass scrapes against edges of case or against each other, see **TROUBLESHOOTING - FRONT GLASS ALIGNMENT ISSUES** section in this manual.

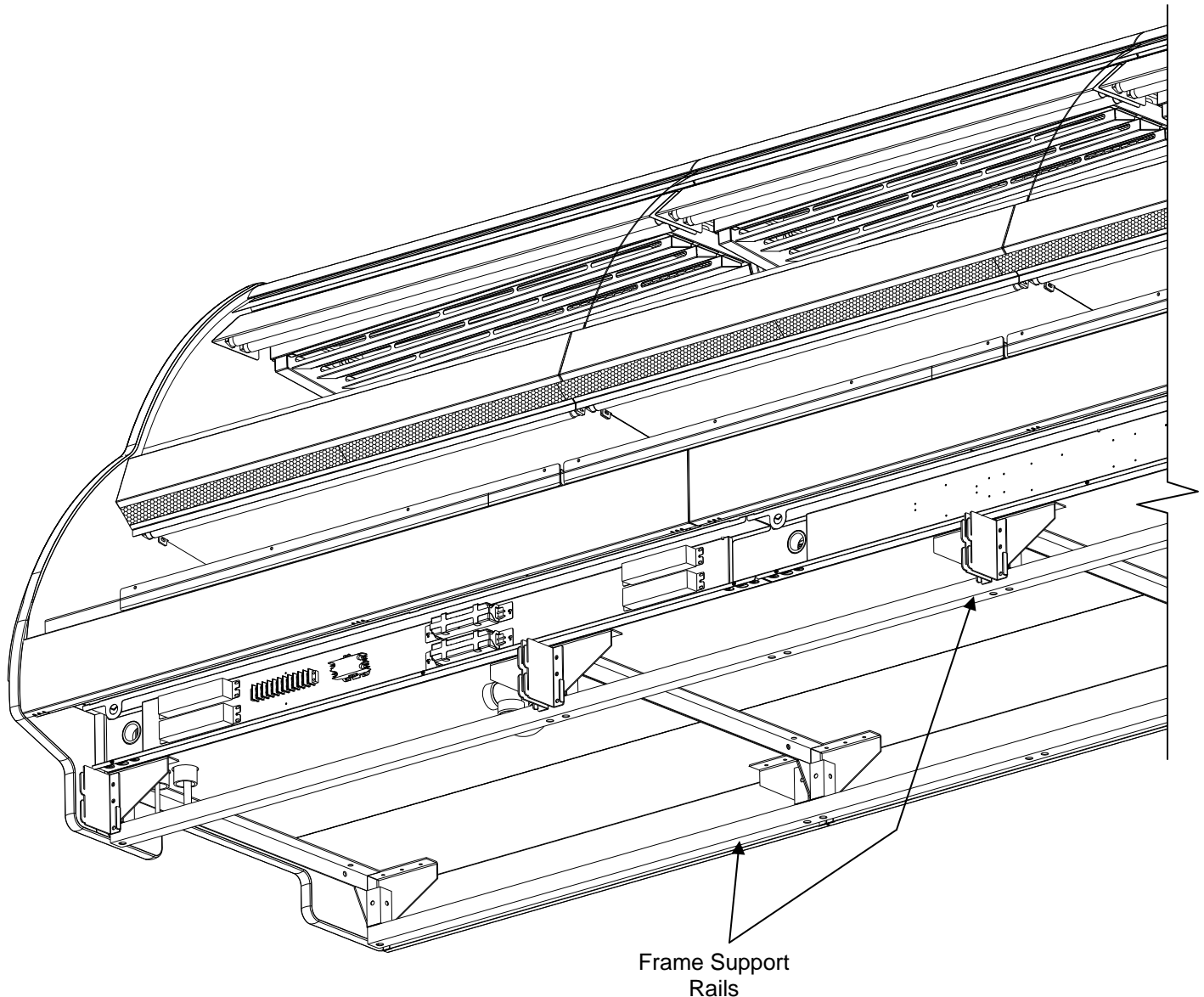

Note: Above Illustration May Not Depict An Exact Representation Of Your Particular Unit Being Installed.

7. Adjust Levelers

- After case is in position, adjust case so it is level and plumb see illustration below.
- You may need to remove front and/or rear Toe-Kick to access levelers.
- Use adjustable wrench (and possibly a pry bar) to adjust leveler.

- Do not use pry bar on toe-kick (it may buckle).
- Do not use pry bar on end panel (it may chip).
- Use pry bar ONLY on base frame to avoid damaging case.
- Use a block to reach base frames with pry bar.
- **Note:** Illustration below may not exactly reflect every feature or option of your particular case.

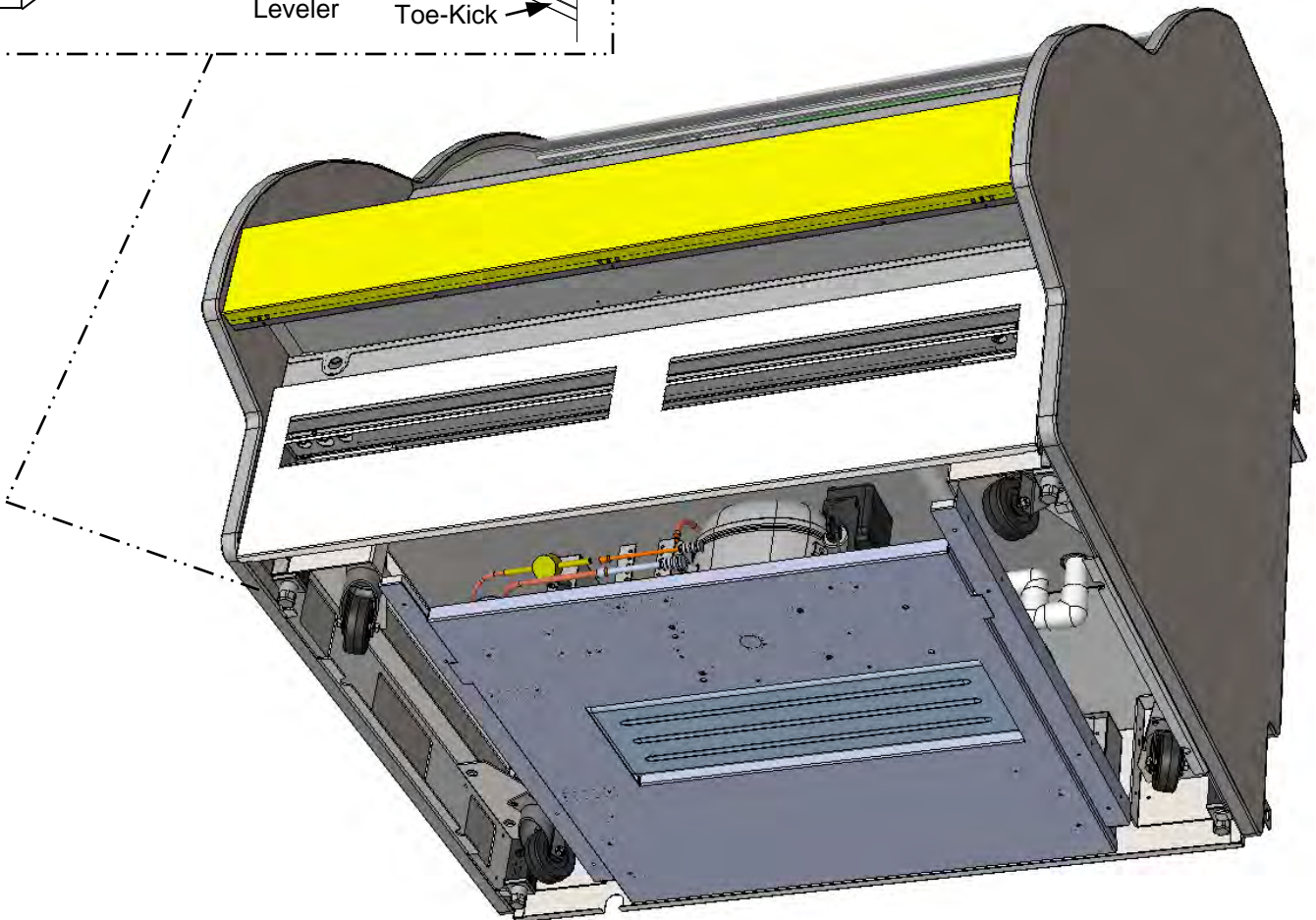
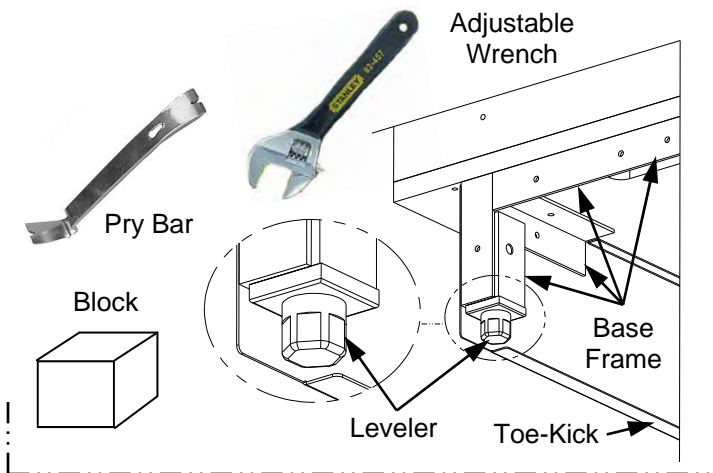

8. Temperature & Defrost Control

- Both temperature controller and defrost controller are remotely controlled.
- Consult store management for guidance and instructions.

9. Rear Panel Removal

- No screw removal is required.
- Lift lower front panel slots up and off case hooks.
- Replace in same manner it was removed.

10. Thermometer Placement & Purpose

- Front thermometers are located against rear plenums.
- Rear thermometers are located in rear storage bins above shelves (at angled positions).
- Also, rear thermometers are in upper section just inside rear doors (as shown below).
- Thermometers may be either spirit-filled or digital. They reflect internal air temperature only (not actual food temperature).
- Use probe thermometers to determine actual product temperatures.

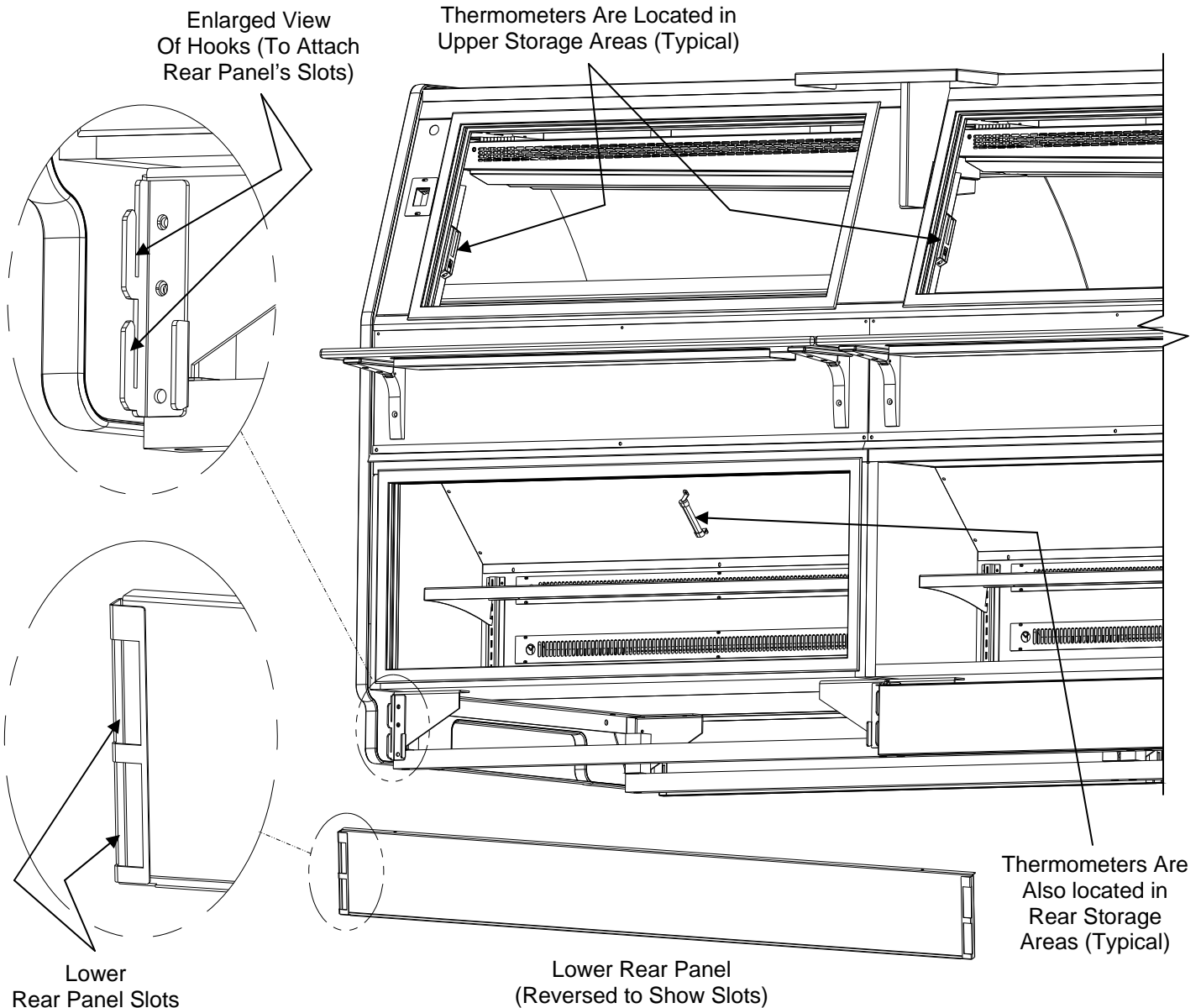

STORE PERSONNEL SECTION ONLY

1. Ballasts and Field Wiring Box

- Electrical raceways contain various electrical components.
- Access to these components can be made simply by removing raceway cover.

- See illustrations below for general layouts.
- ***Caution! Only certified electricians are to access electrical components!***

Electrical Component Raceway (For Multiple Model Layouts) is Shown Below
(Your Case's Model and Layout May Vary)

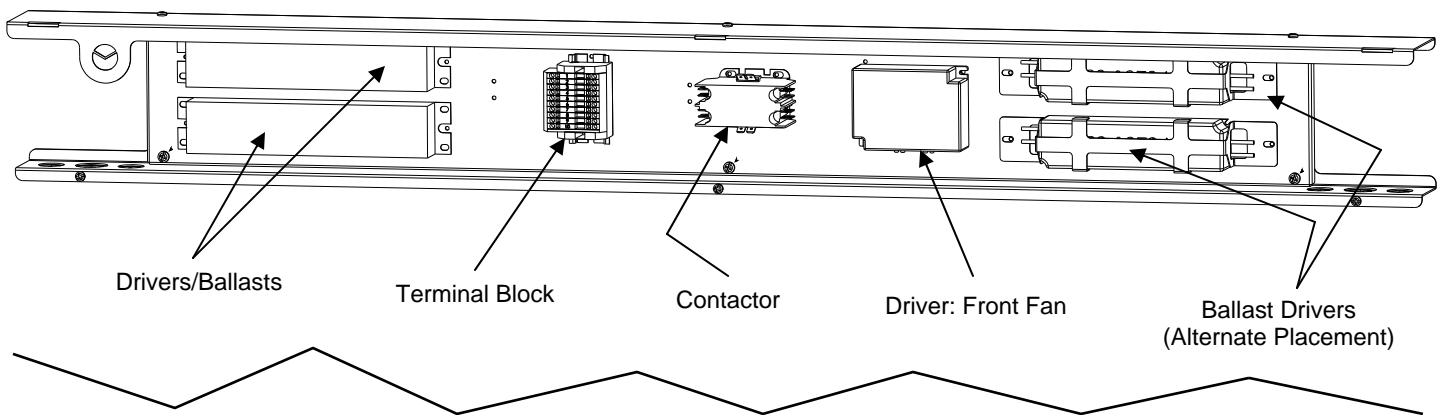

Model GCDT1256RLB is Shown Below
(Your Component Layout May Vary)

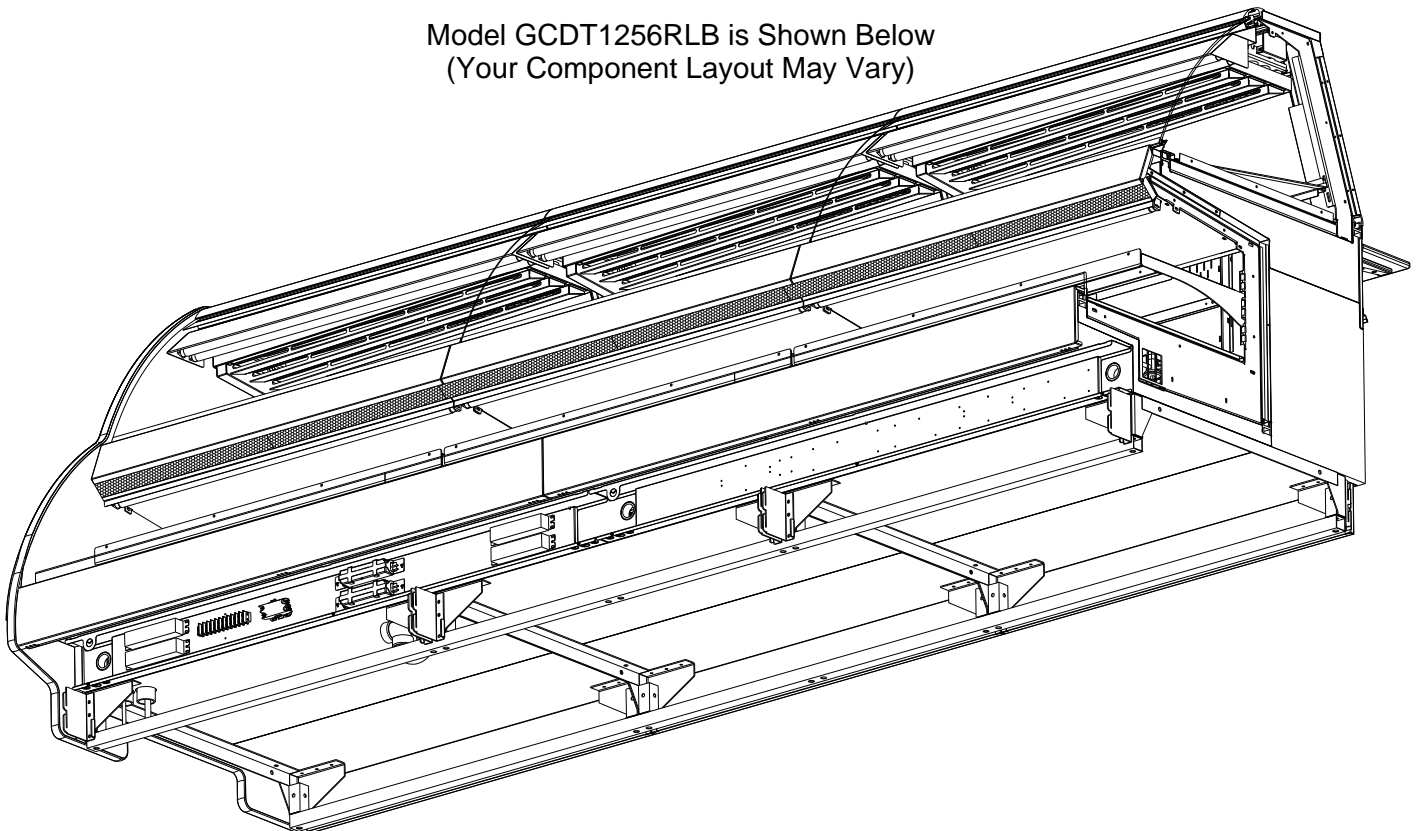

2. Main Power Switch

- Self-Contained units have main power switch at case rear.
- When main power switch is turned on, power is provided to entire case.
- See illustration below.

3. Thermostat

- Self-Contained units have temperature controlled by thermostat.
- Thermostat is located at case rear (as shown as illustration below).
- See **OPERATION, CONT.: DISPLAY CASE LIGHTS, TEMPERATURE CONTROLLER, SST** section in this manual for additional information.
- See entire Carel Controller section in this manual for detailed information including programming, user interface and operating parameters.

4. Scale Stand / Power Outlets / CAT5 Receptacle

- Depending upon the model, there can be one or several scale stands.
- Scale stands have power outlets for scale stand plug, etc.
- Scale stands also may have CAT5 receptacles for on-line connection capability.
- See illustration below.

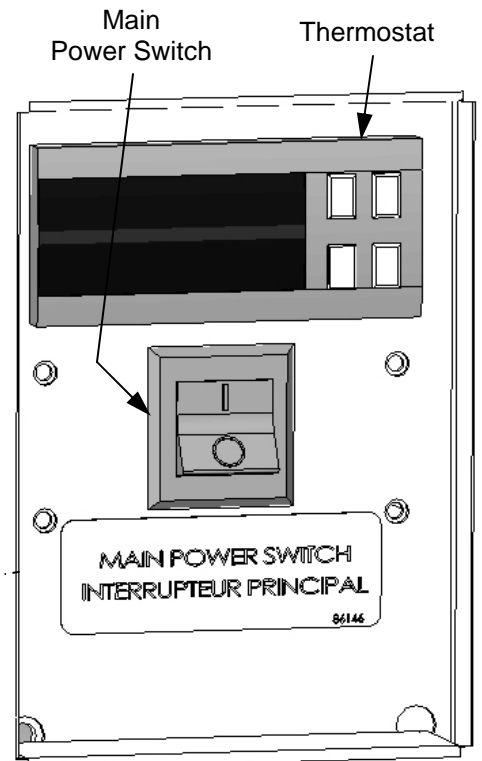
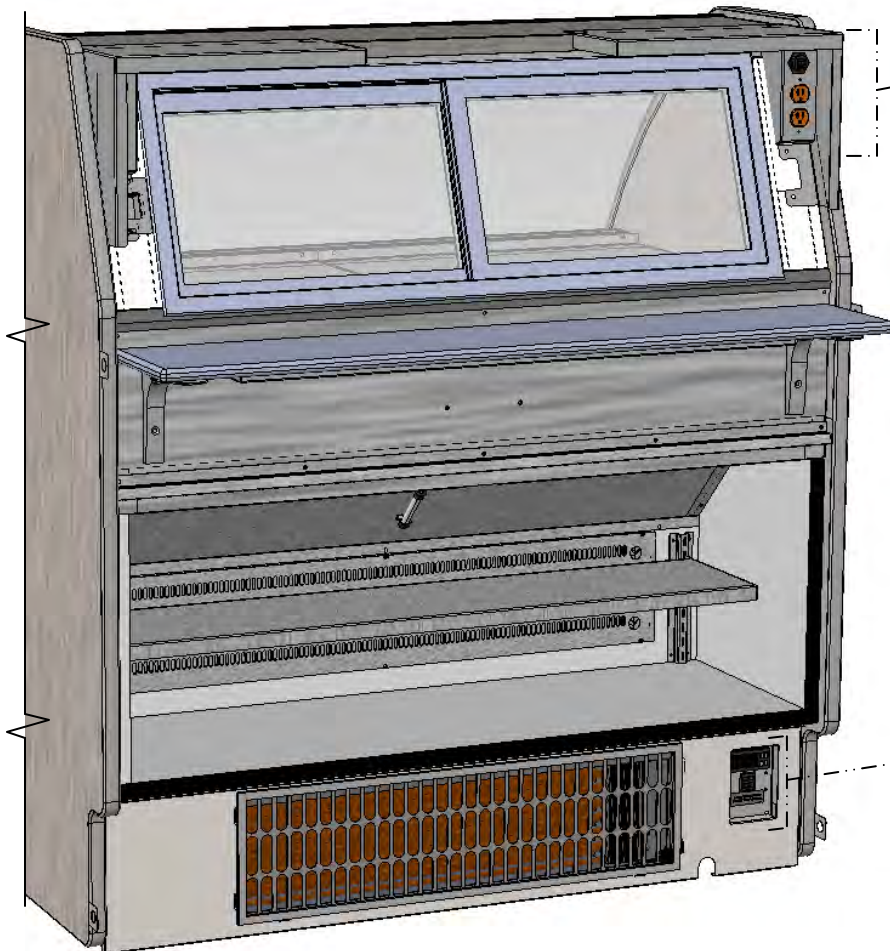
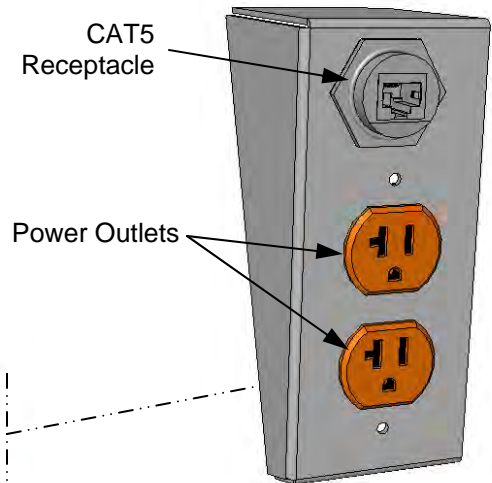

5. Blower Coil Unit (Deli Case) Refrigeration Lines / Stub-Ups / Drain, TXV, Etc.

- Illustration on this sheet is applicable to model GCDT856RLB only.
- See next page for illustration pertaining to model GCDT656RLB.
- Blower coil units do not have gravity coils nor platter coils.
- Two (2) trough drains are in each case. One (1) is at each end of case (as illustrated on next page).
- See illustration below for locations of components under upper and lower section decks.

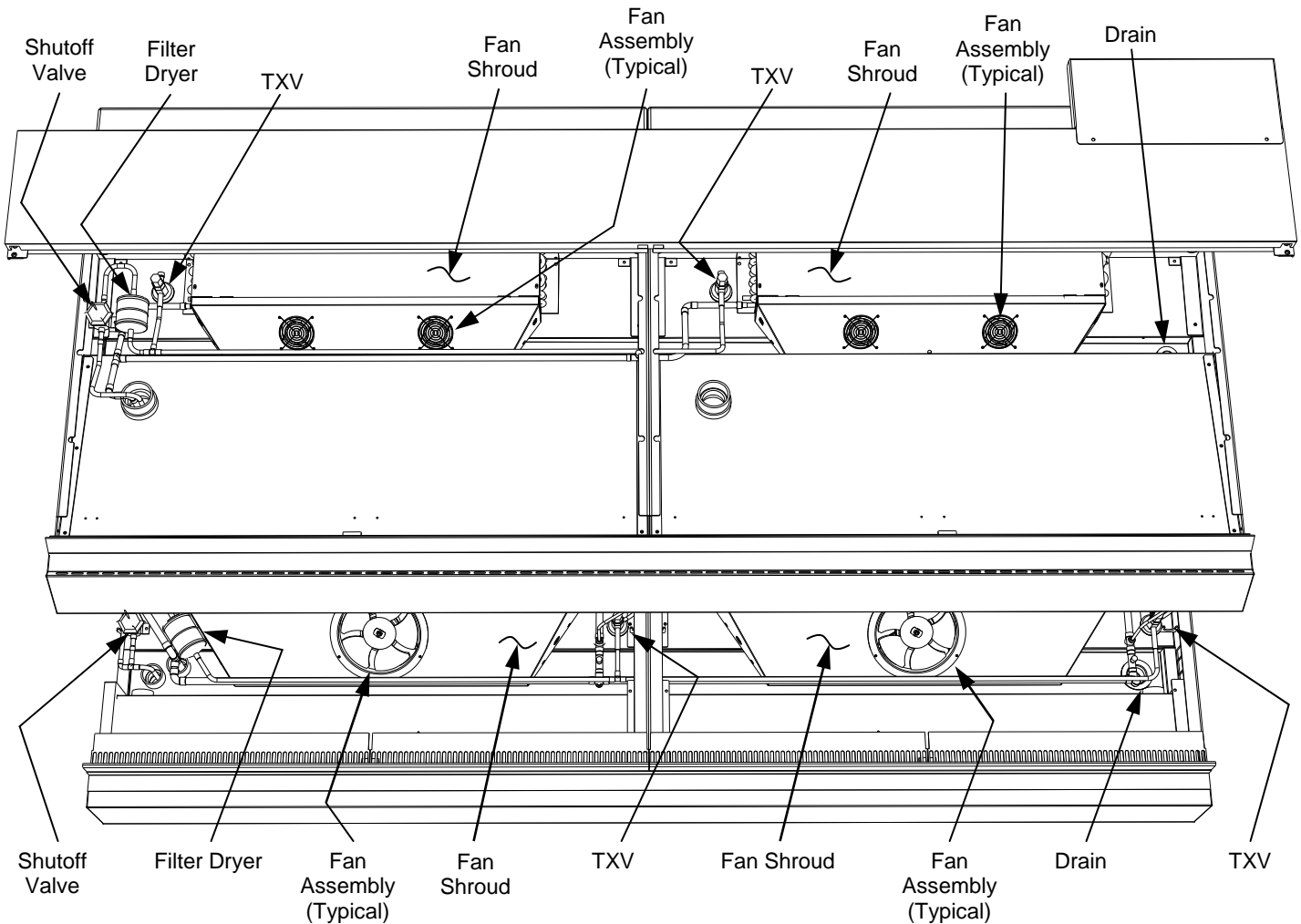

Note: Model GCDT856RLB (Shown Above) May Not Depict An Exact Representation Your Unit Being Installed.

6. Blower Coil Unit (Deli Case) Refrigeration Lines / Stub-Ups / Drain, TXV, Etc.

- Illustration on this sheet is applicable to model GCDT656RLB only.
- See previous page for illustration pertaining to model GCDT856RLB.
- Blower coil units do not have gravity coils nor platter coils.
- Two (2) trough drains are in each case. One (1) is at each upper section / one is at lower section.
- See illustration below for locations of components under upper and lower section decks.

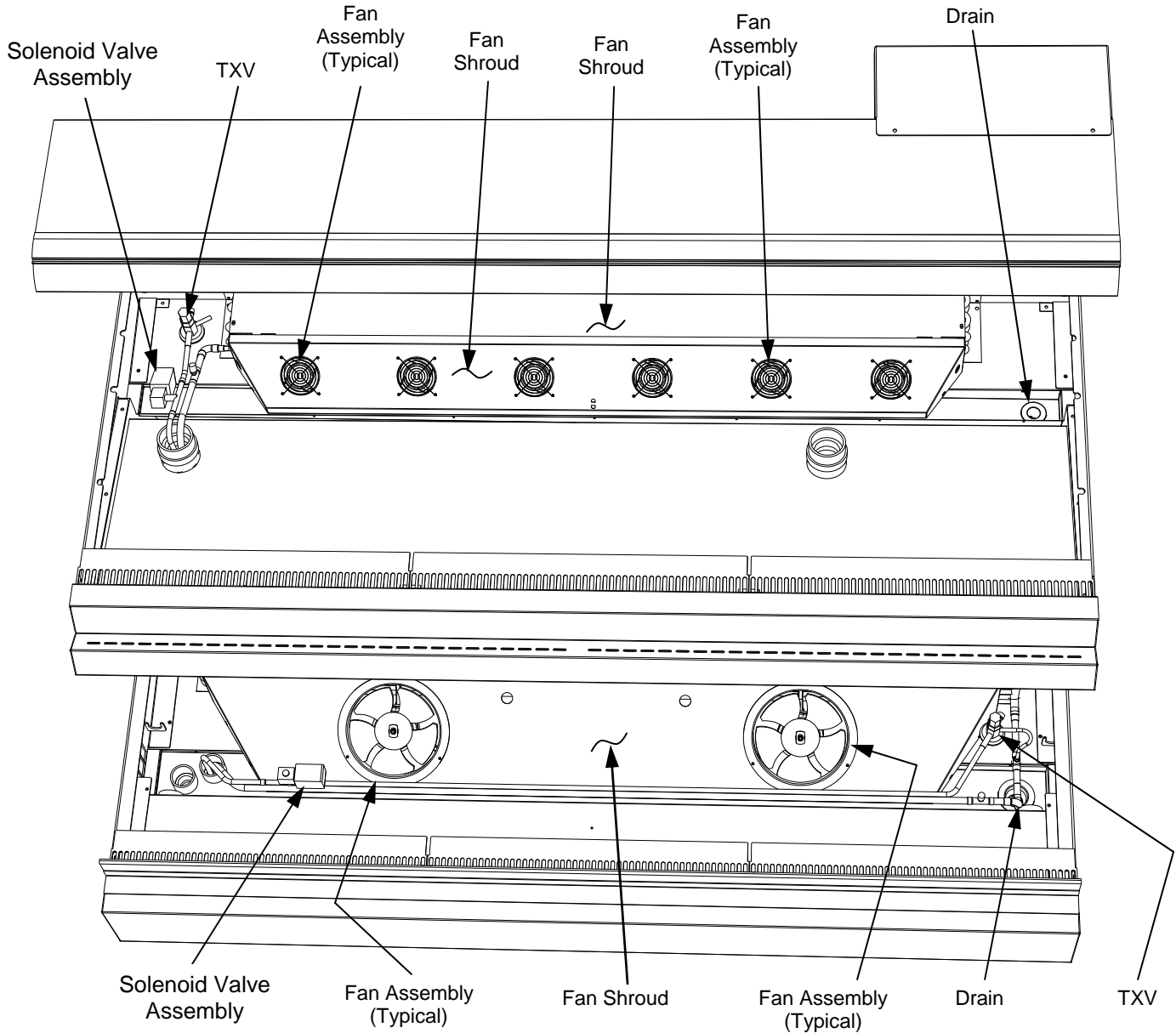

Note: Model GCDT656RLB (Shown Above) May Not Depict An Exact Representation Your Unit Being Installed.

7. Platter Coil Unit (Meat Case) Refrigeration Lines / Stub-Ups / Drain, TXV, Etc.

- Illustration on this sheet is applicable to model GCDT856RLB only.
- See next page for illustration pertaining to model GCDT656RLB.
- Platter coil units also have gravity coils above. No ice trays.
- Two (2) trough drains are in each case. One (1) is at each upper section / one is at lower section.
- Also, see illustration below for locations of components under upper and lower section decks.

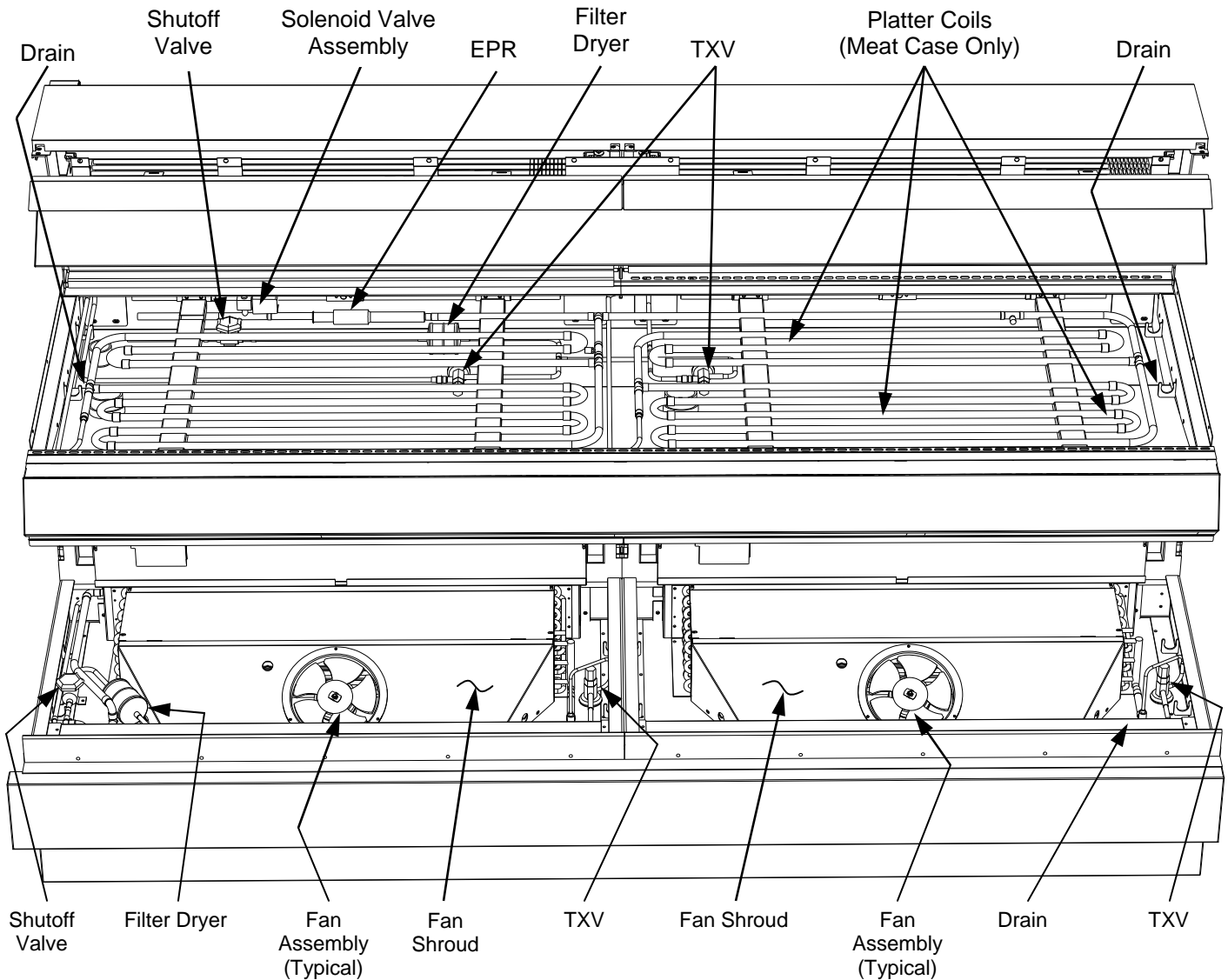

Note: Model GCDT856RLB (Shown Above) May Not Depict An Exact Representation Your Unit Being Installed.

8. Platter Coil Unit (Meat Case) Refrigeration Lines / Stub-Ups / Drain, TXV, Etc.

- Illustration on this sheet is applicable to model GCDT656RLB only.
- See previous page for illustration pertaining to model GCDT856RLB.
- Platter coil units also have gravity coils above. No ice trays.
- Two (2) trough drains are in each case. One (1) is at each end of case (as shown in illustration below).
- Also, see illustration below for locations of components under upper and lower section decks.

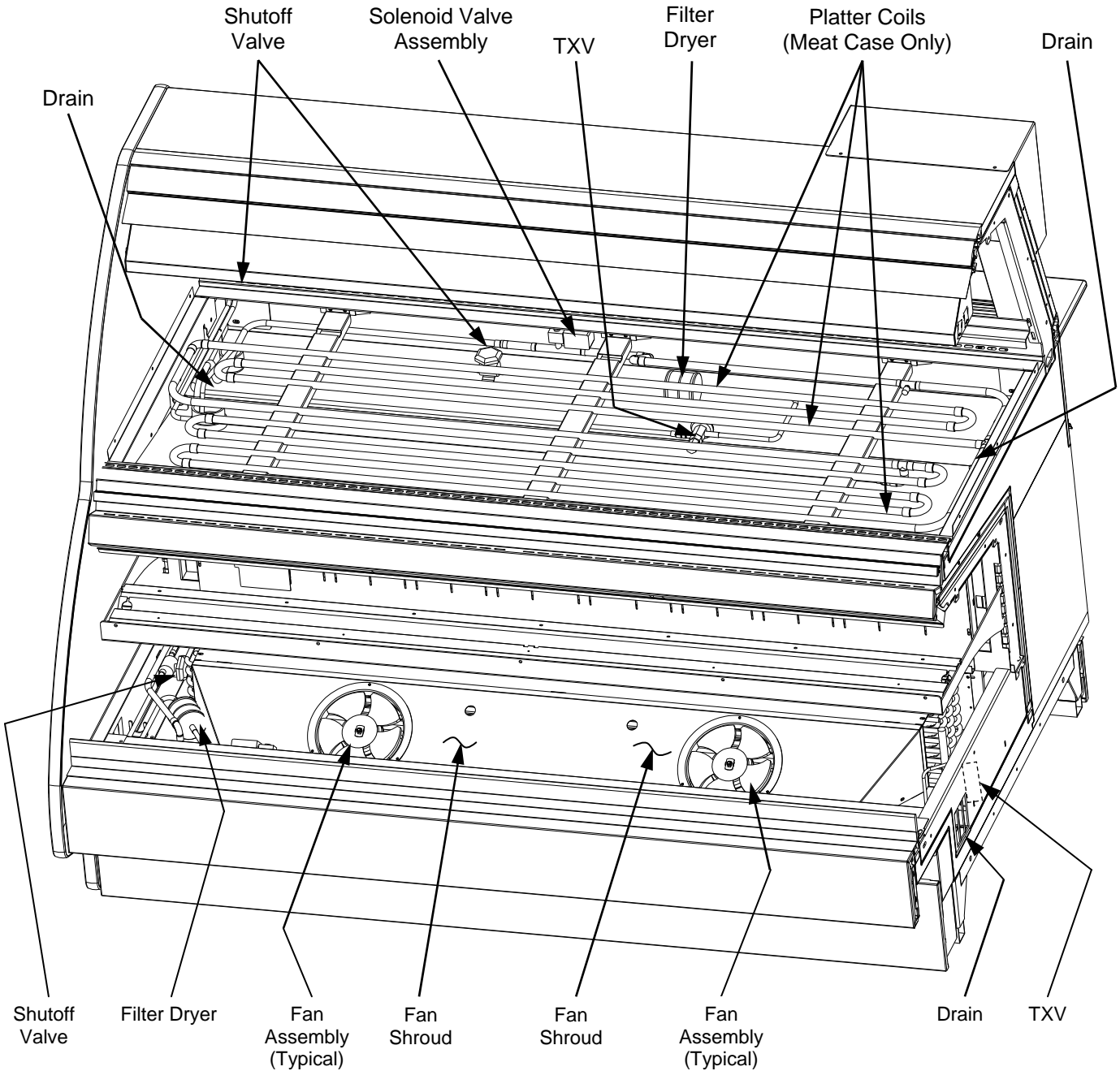

Note: Model GCDT656RLB (Shown Above) May Not Depict An Exact Representation Your Unit Being Installed.

9. Gravity Coil Unit With Ice Trays (Seafood Case) Refrigeration Lines / Stub-Ups / Drain, TXV, Etc.

- Ice trays have been removed for illustrative purposes.
- No blower coils are in upper section of case.
- Each of the three (3) sections has a drain.
- See illustration below for locations of components under upper decks.
- See previous sheets for location of components under lower decks.

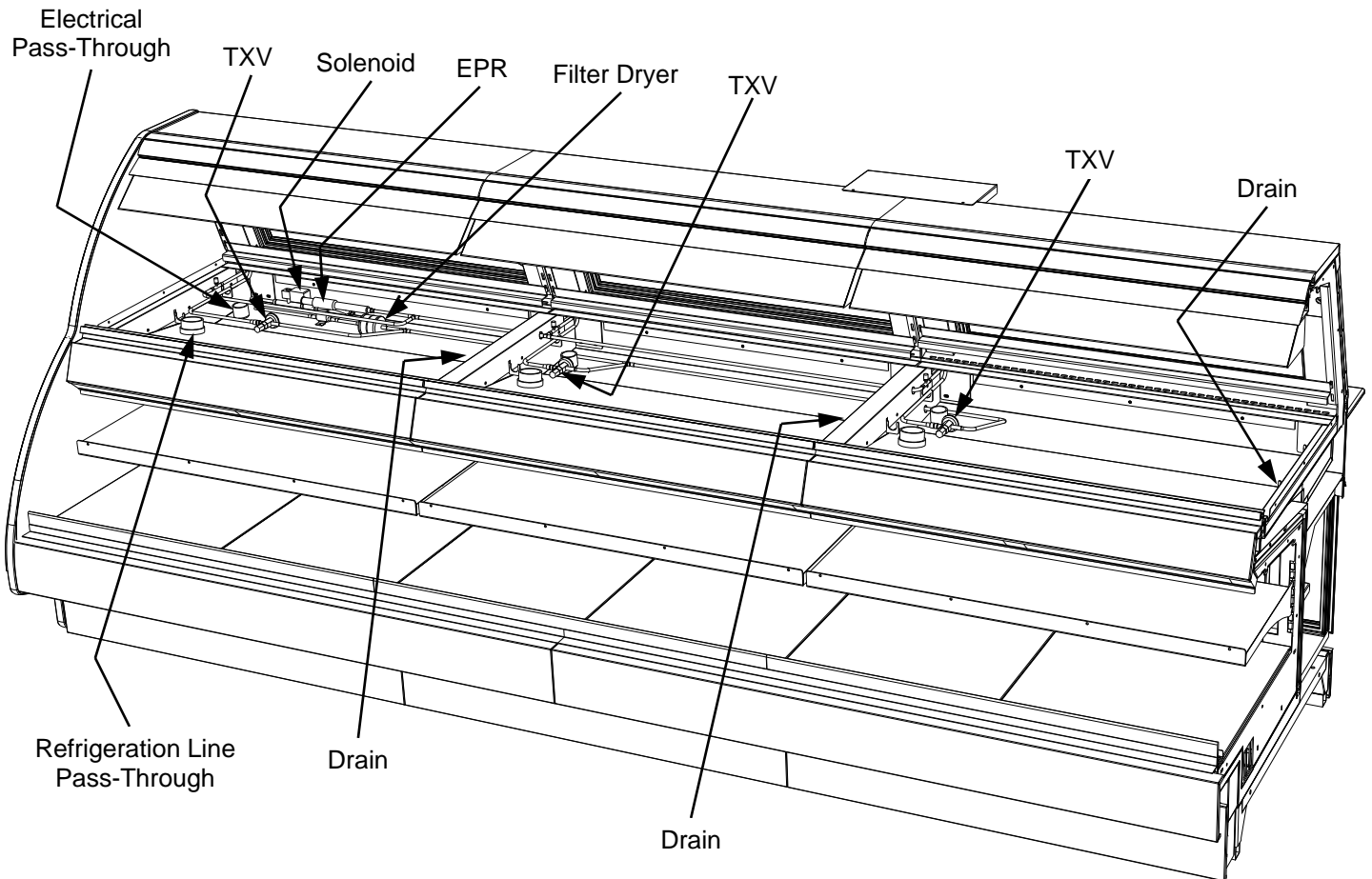

Note: Model GCDT1256RLB (Shown Above) May Not Depict An Exact Representation Your Unit Being Installed.

10. Drain Connection

Lower front panel may be removed to access the drain stub-up for upper section drain. See

INSTALLATION: REMOVAL FROM SKID, REMOVING VERTICAL LOWER FRONT PANEL

section in this manual for removal instructions.

- After access, panels must be replaced in reverse order they were removed.
- Connect tub drain to floor drain. Maintain 1/4"-fall per foot to provide proper drainage.

- Note: Illustration below may not reflect every feature or option of your particular case.

12. Axial Fan Access

- Rear axial fan cover panels may be removed (via screw removal) to access axial fans.
- After access, panels must be replaced in reverse order they were removed.

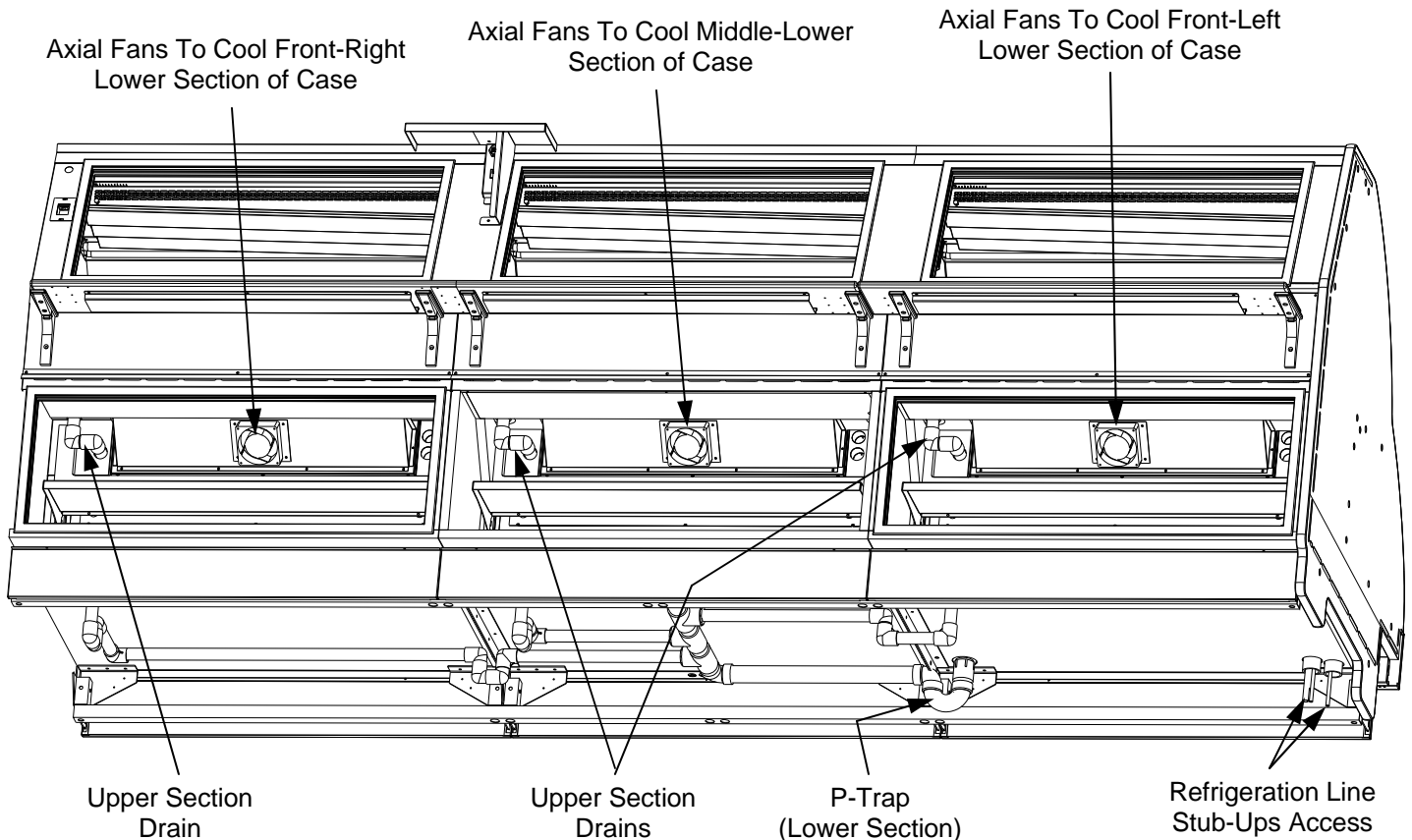

Note: Model GCDT1256RLB (Shown Above).
Panels Have Been Removed to Show Axial Fans.

11. Adjustable Decking (Gravity Coil Cases)

- Decks can be angled to allow more consistent water drainage.
- Ice pan brackets have hooks that are to be placed in either lower or upper slots in uprights.
- Lower slots will raise decking 4°.
- Upper slots will raise decking 8°.
- To adjust, simply lift ice pan brackets up and out of notches in uprights.
- Move bracket up, down or remove entirely from case. See illustrations below.

12. Humidification Feature

- Humidification feature allows the case to retain proper humidity levels without 'wetting' the product.
- The ultrasonic nozzle produces a fine vapor fog ("mist") behind ice pan bracket that permeates entire upper section of case.
- Misting prevents the 'drying effect' of refrigeration.
- See illustration immediately below.

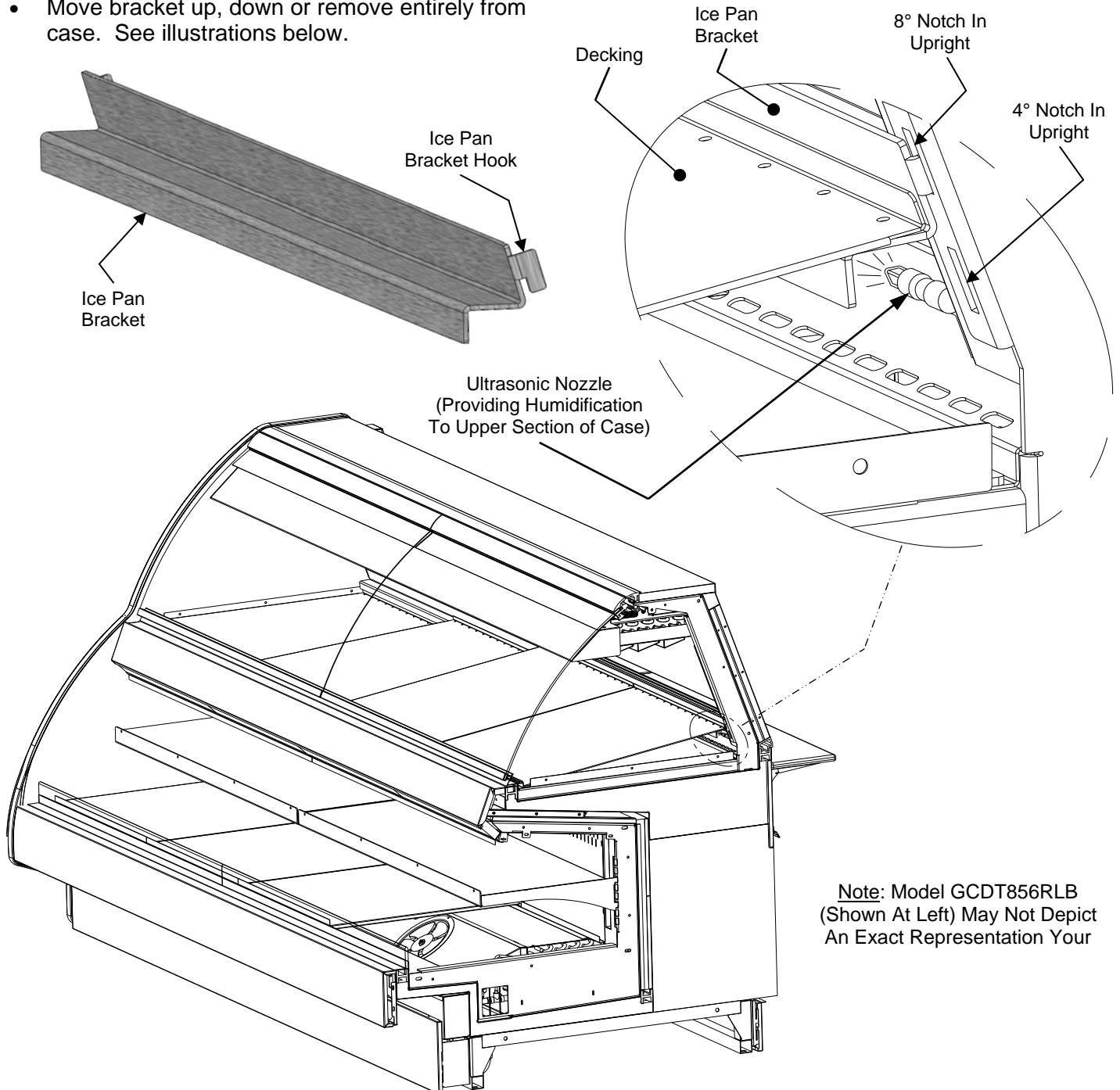

Note: Model GCDT856RLB (Shown At Left) May Not Depict An Exact Representation Your

13. Display Case Start-Up

A. Case

- Unit will begin operating when properly field wired.
- Lift deck to check that coil fans are running.
- Coil fans (and in self-contained units, compressor motor) should turn on.

B. Light Switches

- Light switch for top section are usually at rear of case at left. See illustration below.
- Light switch for lower section is usually at case front at left (on rear plenum). See illustration at lower left.

- See next page for specifics regarding lighting sequence, warm-up, receptacles, etc.
- Lighting is wired in series so **all lights must be plugged in or receptacles capped** for case lights to be on.

C. Rear Storage Areas

- Illustrations below-right show rear storage areas.
- Rear sliding doors provide access.
- Rear sliding doors are removed for illustrative purposes only.

D. Rear Shelving

- Rear shelving and bracketry is adjustable on 1" rail slots.
- See illustrations below.

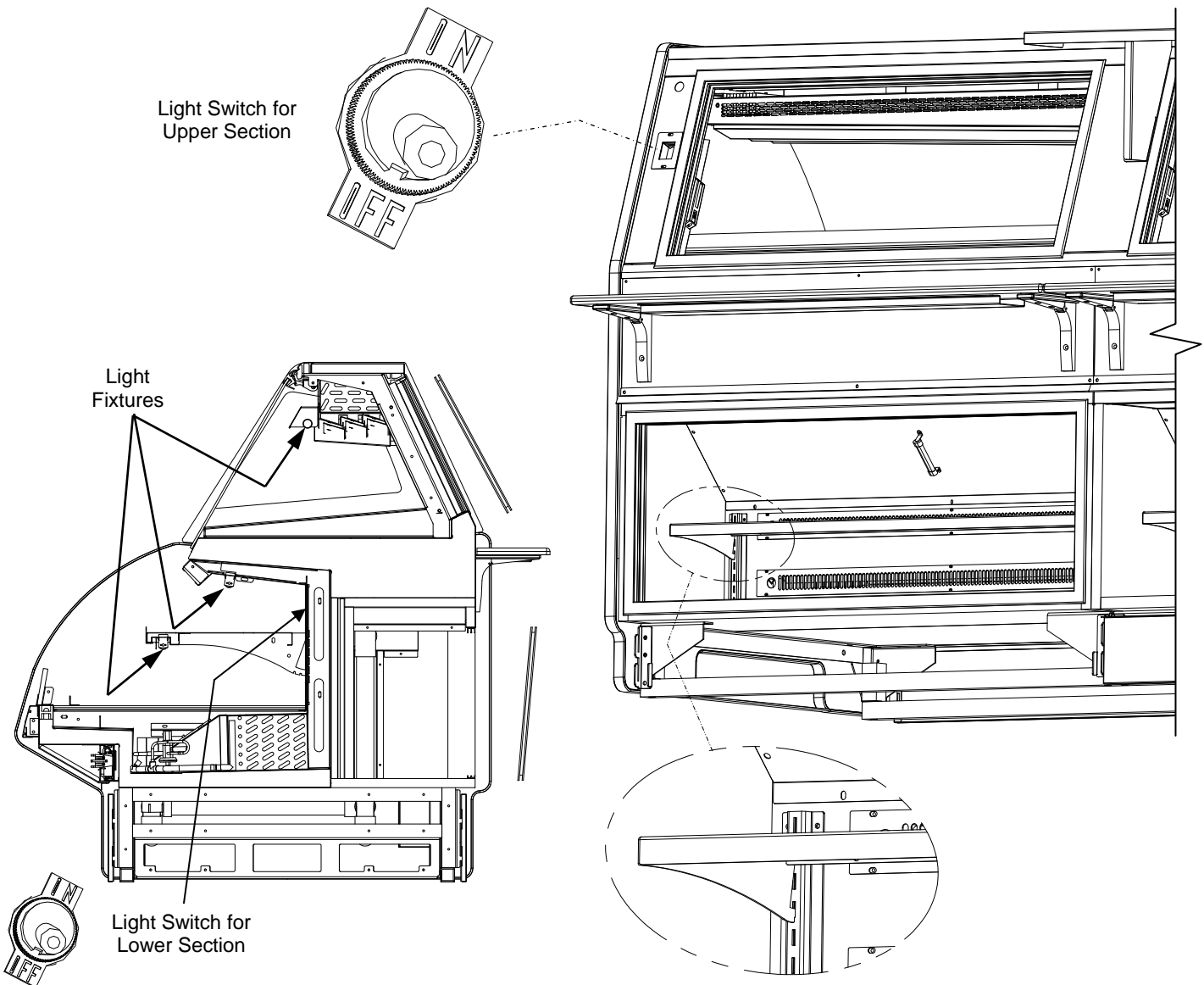

14. Display Case Start-Up, Continued

E. Lights

- Turn lights on.
- All lights should come on at the same time.
- First time lighting may require a short warm-up period.
- Slightly dim / flickering of new bulbs is normal. If lights do not turn on, check raceway plugs.
- Lighting is wired in series so **all lights must be plugged in or receptacles capped** for case lights to be on. See illustration below right.

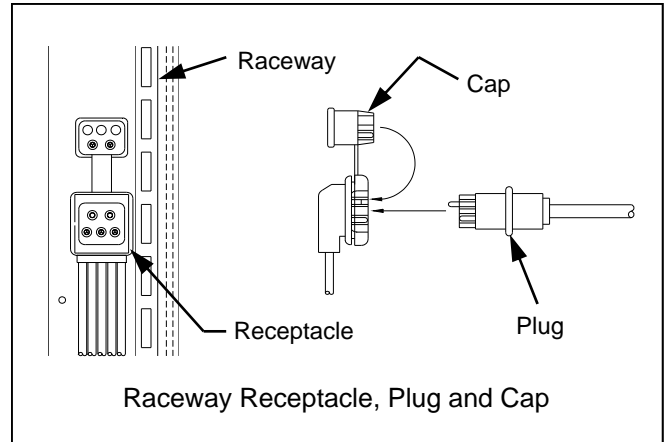

F. Temperature Controller (All Self-Contained Units and some Remote Units)

- If compressor is functioning, the compressor symbol will be on (shown at left).
- Check that compressor symbol light is on.
- After case has run for a few minutes, check that temperature starts to drop.
- If temperature controller does not begin cooling (in a few minutes) see temperature controller section in this operating manual for instructions.
- Verify that refrigeration requirements listed on serial label (found on the case) are being met.
- See *TEMPERATURE CONTROLLER - CAREL®* section in this manual for additional information.



Sample Carel® Controller Face

G. Saturated Suction Temperature (Remote Units)

- See serial label on case for suction temperature requirements and BTU requirements.
- See serial label on case for defrost schedule and temperature termination parameters.

1. Stocking

- Improper temperature and lighting will cause serious product loss. Discoloration, dehydration and spoilage can be controlled with proper use of the equipment and handling of product.
- Product temperature should always be maintained at a constant and proper temperature. This means that from the time the product is received, through storage, preparation and display, the temperature of the product must be controlled to maximize life of the product.
- These cases are not designed to “cool down” product - but rather to maintain an item’s proper temperature for maximum shelf life.

2. Maintaining Proper Product Condition

To achieve and maintain proper product condition:

1. Minimize processing time to avoid damaging temperature rise to the product. Product should be kept at proper temperature.
2. Keep the air in and around the case area free of foreign gasses and fumes or food will rapidly deteriorate.
3. Maintain the display merchandisers temperature controls as outlined in the refrigerator section of this manual.
4. Do not place any product into these refrigerators until all controls have been adjusted and they are operating at the proper temperature. **Allow merchandiser to operate at a minimum of 6 hours before stocking with any product.**
5. When stocking, never allow the product to extend beyond the recommended load limit. Air discharge and return air flow must be unobstructed at all times to provide proper refrigeration.
6. There are vents located at the base of the front of the glass, just above the front rail. These vents supply a continuous, gentle flow of air across the front glass which inhibits condensation. Do not place any signs or other restrictive objects on the front of the refrigerator that will block these vents.
7. Keep the service doors closed (when applicable). Refrigeration performance will be seriously affected if left open for a prolonged period of time.
8. Avoid the use of supplemental flood or spot lighting. Display light intensity has been designed for maximum visibility and product life at the factory. The use of higher output fluorescent lamps (H.O. and V.H.O.), will shorten the shelf life of the

product.

9. In the Deli, Meat and Fish cases, completely cover the product each night with a clean damp cloth or butcher paper (never use plastic, as it does not allow for proper circulation). Make sure the cloth or paper is in direct contact with the product.
10. Turn and rotate the meat fairly often. The blood which gives the pink color works its way downward with time.
11. Cold coils remove heat and moisture from the case and deposit this as frost onto the coil. Thus, a defrost is required. Our humidity system induces moisture into the case and helps slow down the dehydration process. The only other moisture within the case is that in the product itself. A single level of meat will dry out faster than a fully loaded case of 3-4 levels of meat.

3. Important Procedures

1. Do not set temperature too cold, as this causes product dehydration.
2. Product should be worked and rotated on a regular basis, not to exceed a 4 hour period.
3. At night, turn off case lights and cover the product with a damp (not wet) cloth similar to cheese cloth (etc.). This should be washed out in the morning and kept in a walk-in box during the day-so that it is cool and moist when covering the product.
4. Clean humidity system a minimum of every 90 days for proper system operation.

MAINTENANCE: REAR SLIDING DOORS / STANDARD LIGHT FIXTURES

Warning! Disconnect power before providing maintenance and service to unit.

Caution: Lamps are treated to resist breakage and must be replaced with similarly treated lamps.

Note: Warranty will be void if claims arise from negligence, misuse of goods, extreme environmental conditions or improper maintenance. See OVERVIEW / TYPE / COMPLIANCE / WARNINGS / PRECAUTIONS / WIRING / PLUGS section in this operating manual.

1. Rear Sliding Doors

Note: Doors are not interchangeable. There is an inner and outer door. Outer door must be removed first and replaced last.

- The outer door is the right hand door (from the service side or rear of case).
- Move doors toward the center of the case.
- Individually lift each door up toward the top of the case; pivot the bottom of the door out.
- Replace rear sliding doors in reverse order they were removed.

2. Light Fixtures

Note: Depending upon model and options, light fixtures can have either single or dual lamps.

Light fixtures are located on underside of shelf assemblies and at the top inside of case. See illustration at upper right for locations.

Removal of lamps:

- Rotate lamp (1/4-turn) to disengage (upper or lower) pins/contacts from mounting sockets.
- Remove bulb by applying even pressure from back side at the bulb ends and pulling the remaining contact from sockets.
- See illustrations at mid and lower-right.

Installation of lamps:

- Align pins with slot.
- Insert pins into socket by rotating the bulb 1/4-turn to secure either the (upper or lower) pin contacts into the sockets.
- Rotate remaining bulb contacts (1/4-turn) into remaining lamp mounting socket contacts.
- See illustrations at right.

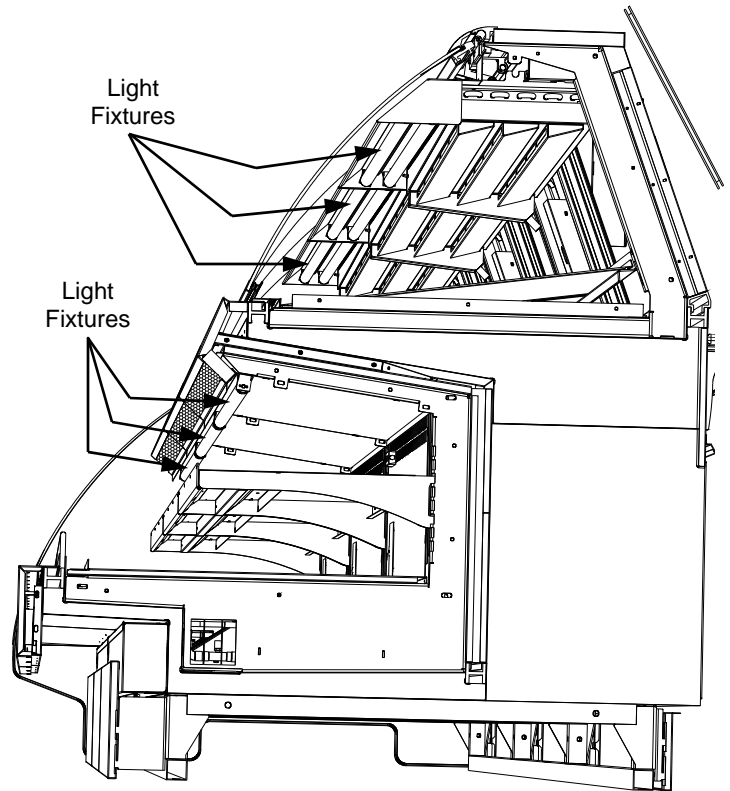

Model GCDT1256RLB With End Panel Removed For Illustrative Purposes Only



3. Supplemental Flood Lighting / Food Lighting Specifics

- Avoid the use of supplemental flood or spot lighting.
- Display light intensity has been designed for maximum visibility and product life at the factory.
- The use of higher output fluorescent lamps (H.O. and V.H.O.), will shorten the shelf life of the product.

4. Bracket Retainer Removal

- To remove brackets, it may be necessary to remove the nylon shipping bracket retainers.
- Pliers will be required to accomplish this task.
- See illustration at top-right for location of bracket retainers.



5. Shelf Assembly Adjustment or Removal

- Shelf can be set at 0°, 5° or 10°.
- To adjust shelving lift upward and rotate to desired angle.
- To remove, unplug the light cord and lift up and out.
- See illustrations at right and below.

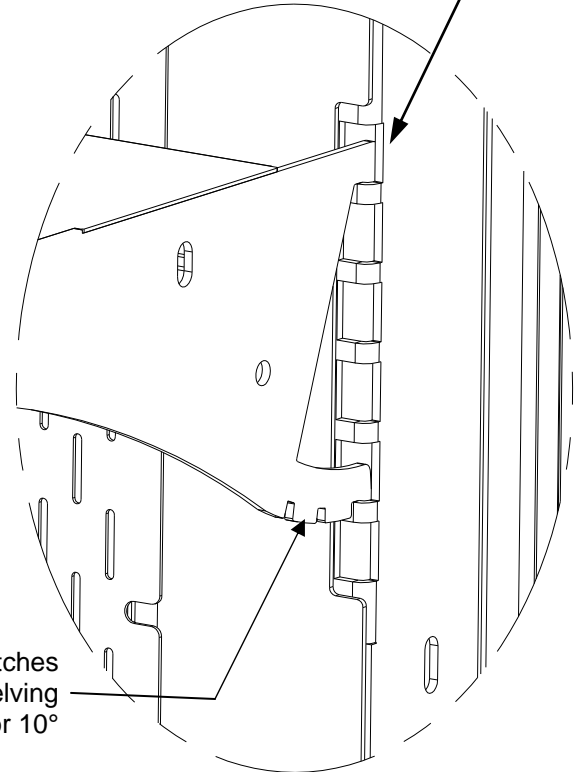

6. Load Limits

- See labels along sides of case stating load limits.
- Do not allow product to exceed these limits.
- Doing so will prevent proper airflow, causing product temperature to warm.
- For upper section, keep ice in trays. Do not allow ice to spill over onto door tracks or behind trays.

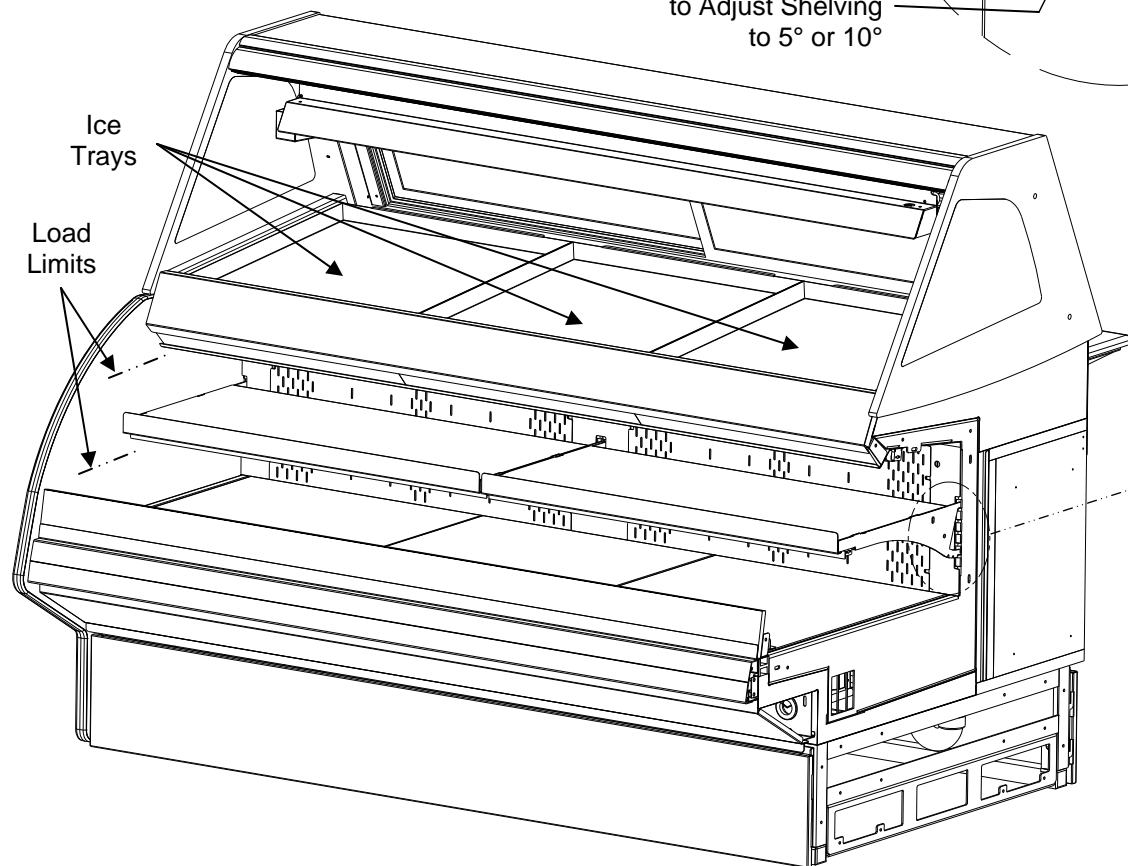

Note:
Illustration
Shown May Not
Depict An Exact
Representation
Your Particular
Case.

7. Prohibited Product Placement

- **Caution! DO NOT set product on misting holes at case rear.** Doing so can impede proper humidity which is required to maintain seafood and/or meat at proper color and proper condition.
- **Caution! DO NOT set product on air return (lower section - front of case).** Doing so can detrimentally affect product temperature.
- See illustration below for locations.

8. Aluminum Deck / Stainless Steel Pan Placement (Meat Case Only)

- **Caution! DO NOT place pans and decks in wrong order onto case!** Doing so can prevent proper drainage and meat condition.
- Illustrations immediately below depict proper order in which stainless steel pan and aluminum deck are to be placed onto meat case.

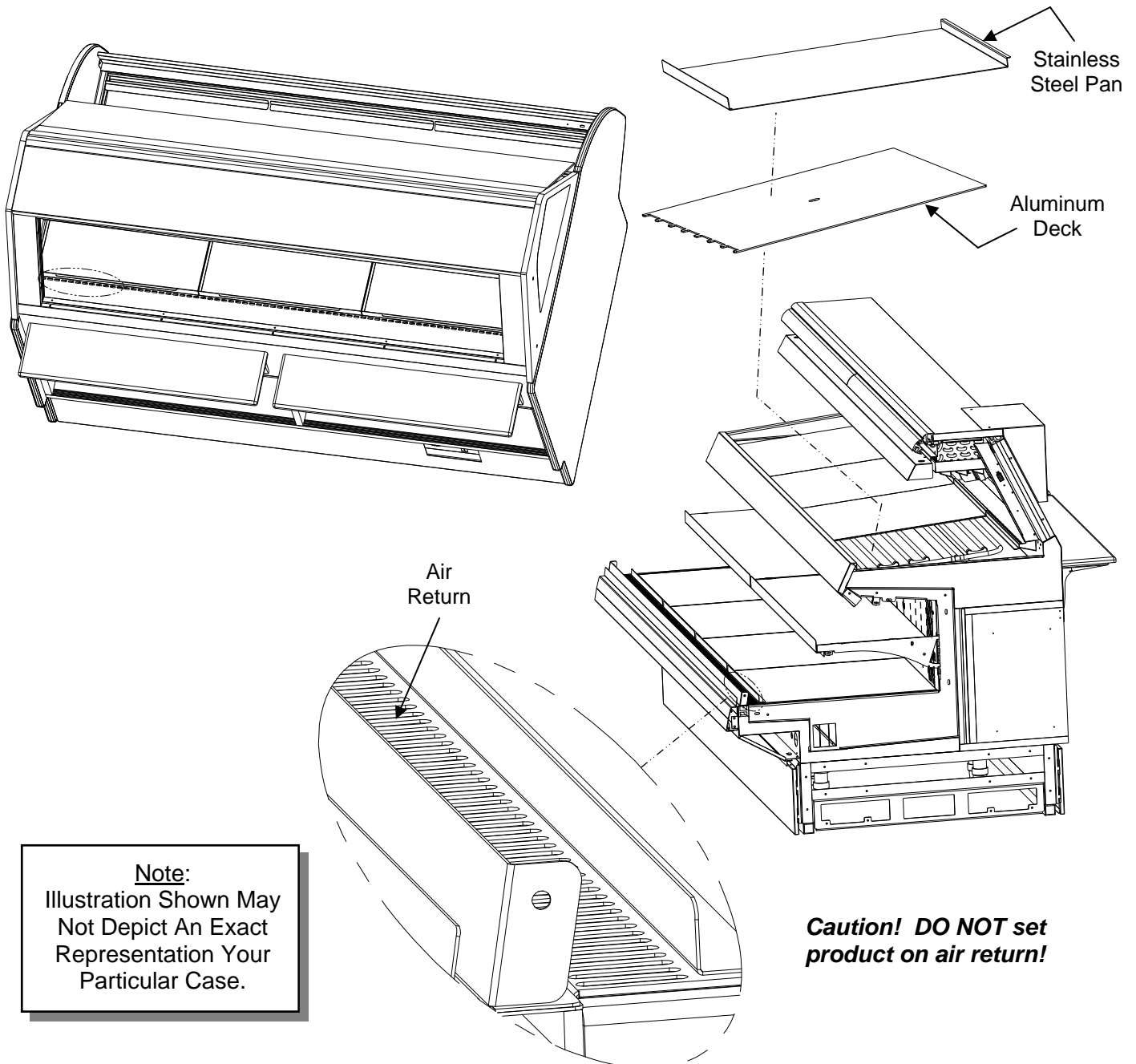

Note:
Illustration Shown May
Not Depict An Exact
Representation Your
Particular Case.

**Caution! DO NOT set
product on air return!**

9. Rear Ledge Removal Steps

Illustrations below reflect step-by-step removal method.

1. Hinged support bracket is shown in its standard upright position.
- 2 & 3. While upright, rear ledge must be slid away from case and then rotated downward to vertical position.
- 3 & 4. From the shelf's lowered position, lift from bottom edge upward to disengage shelf track (and attached rear ledge) from bracket.

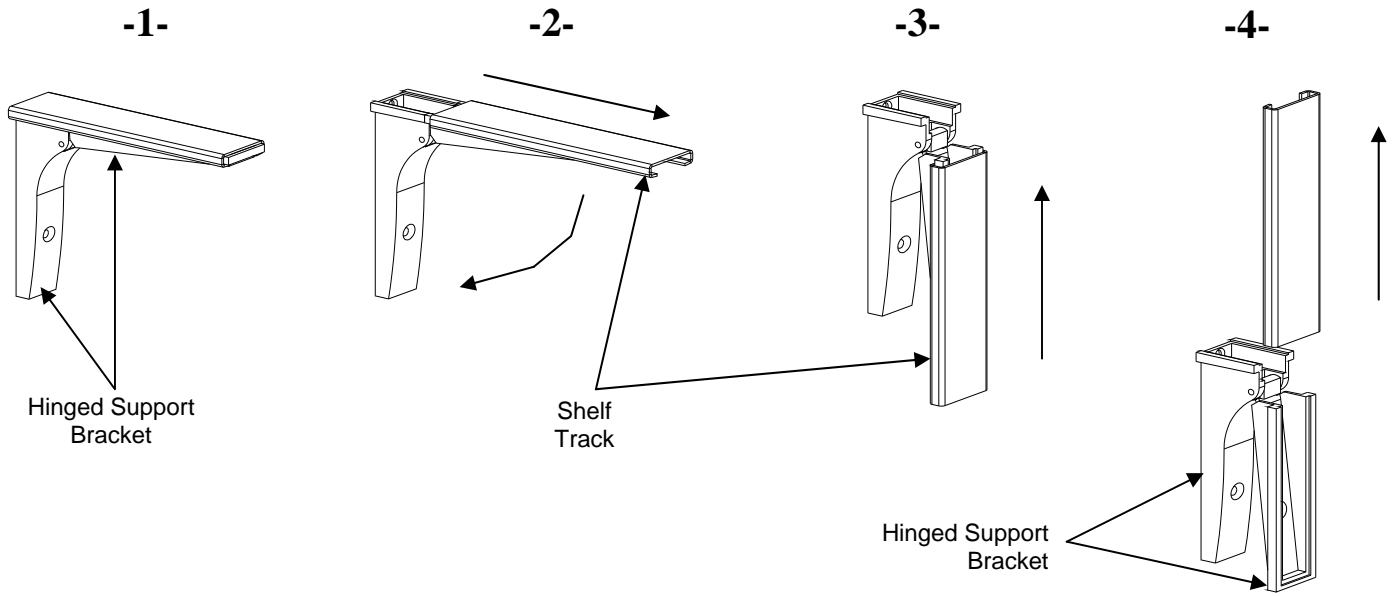

————— Rear Ledge Removal Steps —————
Note: For clarity, only Shelf Track is shown being removed. Rear Ledge is attached to Shelf Track.

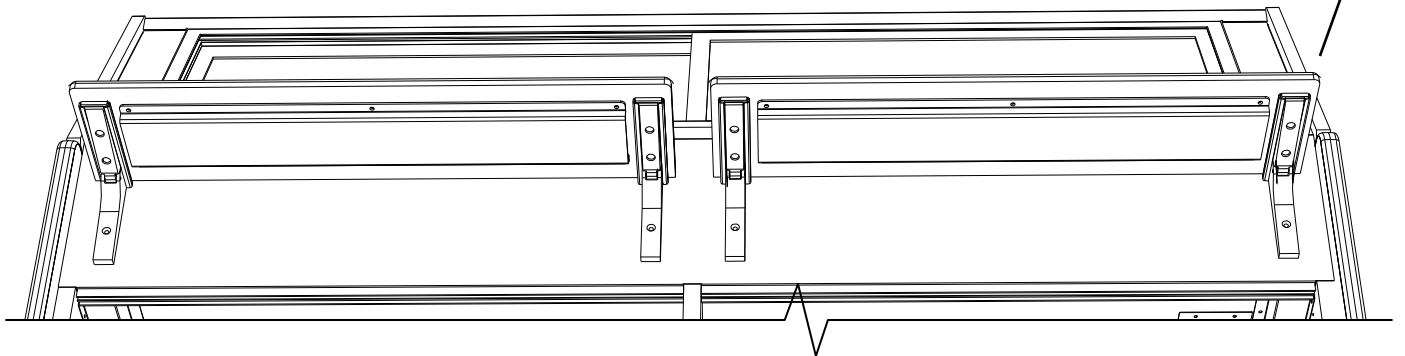

CLEANING SCHEDULE (INTERIOR) - TO BE PERFORMED BY STORE PERSONNEL

AREA	FREQ.	INSTRUCTIONS
Interior	Daily	Upper Section Pans (With Ice) (Seafood Case) / Upper Section Aluminum Decking and Stainless Steel Pan (Meat Case): Remove from case. Submerge pans in hot water while using an anti-bacterial soap solution. Rinse thoroughly and dry. Ice must be new. Return to case.
	Daily	Upper Case Area: While upper pans are being cleaned, wipe down upper section (including drain area) with hot water solution and anti-bacterial soap solution. Rinse thoroughly.
	Weekly	Lower Decks: Wipe off decks with moist cloth dipped in mild soap and water solution.
	Weekly	Tub and Drain (Upper Only): Keep clean and free of debris which could clog tub and drain. To access drain area, remove upper decks. <ul style="list-style-type: none"> • Direct the drain to a floor drain or a bucket. • Run hose into drain to flush out debris. Carefully hose out the tub. • Caution! Avoid splattering water over the case and surrounding areas!
	Monthly	Gravity Coil Tray Drip Assembly: Caution! Authorized personnel must approve and/or supervise this procedure! Turn off case. Lift rear sliding doors up and out from unit. See MAINTENANCE FUNDAMENTALS - REAR SLIDING DOORS section for instructions. Disconnect hose from hose connection spout (may require removal of hose clamp). Remove thumbscrews holding gravity coil tray drip assembly in place. Drop tray drip assembly downward. Lift 'lip' of gravity coil assembly up and off internal hook. Remove from unit. Submerge in hot water using an anti-bacterial soap solution. Rinse thoroughly and dry. Return to case. Reattach thumbscrews. Return rear sliding doors to case. Turn case back on. Note: Defrost timer MAY need to be reset. See illustrations below.

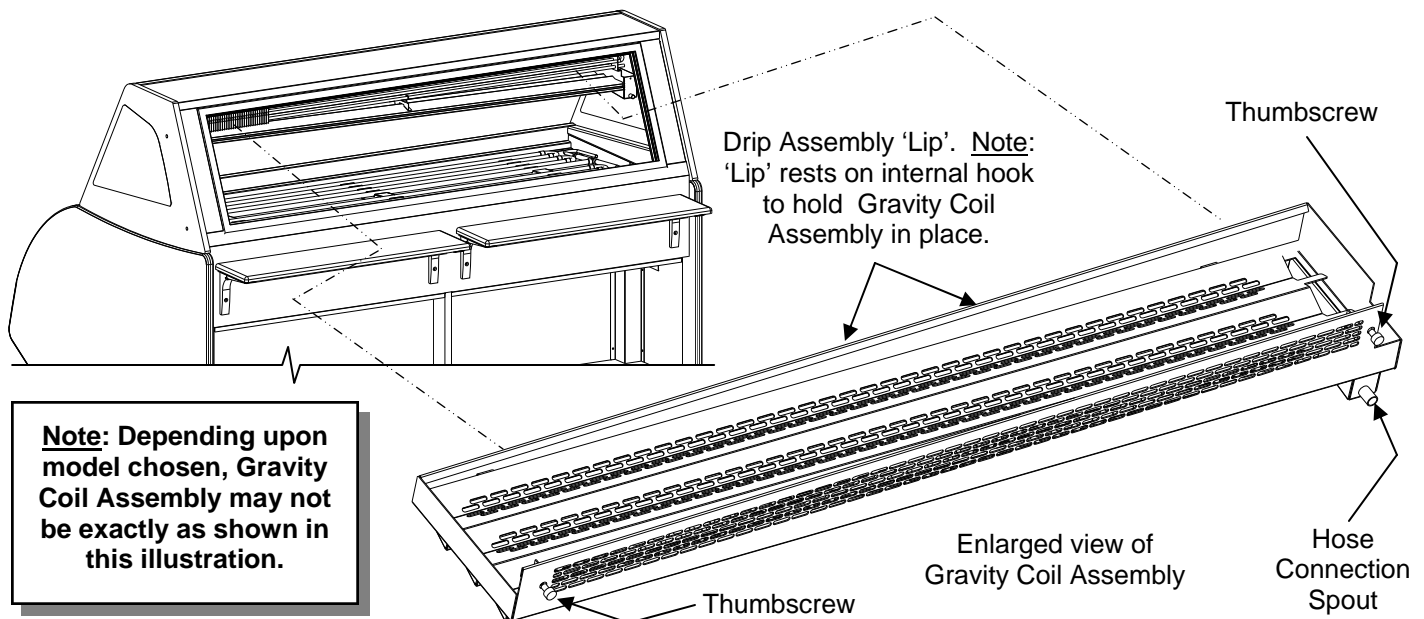

CLEANING SCHEDULE (EXTERIOR) - TO BE PERFORMED BY STORE PERSONNEL

AREA	FREQ.	INSTRUCTIONS
Exterior	Daily	All Glass / Mirrors: Clean side glass, front glass, glass shelves, and mirrors with household or commercial glass cleaner. Clean out door track with moist cloth.
	Daily	Rear Sliding Door Exterior Glass: Clean with household or commercial glass cleaner.
	Daily	End Panels, Front Panel, Toe-Kick, Rear Ledge Cutting Board, etc.: Wipe off all surfaces with warm water and mild soap solution and non-abrasive cloth. Dry thoroughly.
	Daily	<p>Stainless Steel Surfaces:</p> <ul style="list-style-type: none"> • Wash with a solution of hand dishwashing liquid detergent and water; or a solution of baking soda and water. Rinse and polish dry with paper towel or soft cloth. • Never use scouring powders or steel wool as they will scratch stainless steel. • Brighten by polishing with a cloth dipped in vinegar or in ammonia; sprinkle baking soda on sponge and rub gently; rinse. Polish dry with paper towel. • Remove streaks or heat stains from stainless steel by rubbing with club soda.
	Weekly	Wood, Laminate and Painted Surfaces (Including Rear Storage Area): Clean with mild soap and water solution and a soft cloth .
	Weekly	<p>Acrylic (Sneeze Guard): Clean with warm water, mild soap solution and soft cloth; acrylic cleaning solutions are also available.</p> <ul style="list-style-type: none"> • Caution! Never use ammonia-based cleaners on acrylic. • Incorrect cleaning agents or abrasive cleaning cloths cause surface to 'cloud' over time.
	Monthly	Under Case Cleaning: Remove front toe-kick (or rear grille). Vacuum under case to remove all dust and dirt. Replace front toe-kick (or rear grille) when complete.

TROUBLESHOOTING - TO BE PERFORMED BY STORE PERSONNEL

CONDITION	TROUBLESHOOTING
Case Not Lining Up	See <u>Installation Section</u> for instructions on properly aligning case (alongside other cases) and adjusting levelers.
Case Lights Are Not Working	Check that light switches are in the ON position.
	Check for burned out bulbs. Turn lights off & replace.
	Clean dirt and dust from the bulbs to prevent flickering.
	Check to insure voltage at ballasts. If voltage is entering but not exiting the ballast, ballast is faulty.
	Check that ALL lights are plugged in and receptacles capped.
Control Display Is Flashing	Check Carel® Temperature Controller section in this manual.
Water Is On The Floor	<p>Caution! Water on flooring can cause much damage! Until cause is determined (and repaired), following these procedures:</p> <ul style="list-style-type: none"> • Use wet-dry vacuum (or mop & bucket) to remove standing water. • Use 'catch pans' for water to drain into. Swap out regularly until case has completely drained.
	Check that the drain trap is free of debris.
	Check that the drain hose is correctly positioned over floor drain.
	If unable to stop water from draining on floor, Contact Structural Concepts Technical Service. See telephone number on final page in this manual.
Fan Emits Excessive Noise	Check that the case is aligned, level and plumb.
Fans Are Not Working	Check that the MAIN power switch (if present) is on.
System Is Not Operating	Check that the MAIN power switch (if present) is on.
Case Is Not Holding Temperature	If a large amount of warm product was added to the case, it will take time for the temperature to adjust. Product should be pre-chilled before placing in display case.
	Check Carel® Temperature Controller section in this manual to confirm that proper settings are being maintained.
	Check that the case is not in the sun or near a heat or air conditioning vent.
	Check that case is not located near outside doors: ambient temperature fluctuation can hinder unit's ability to maintain proper case temperature.

**TRAINED SERVICE
PROVIDERS
SECTION ONLY**

REFRIGERATION PACKAGE LAYOUT: MODEL GCD456R SELF-CONTAINED UNIT

1. Refrigeration Package Layout

- Illustration shown reflects model GCD856R refrigeration package.
- **Note:** Due to design variables, refrigeration package components layout can slightly vary in location.

- Illustration below may not reflect every feature or option of your unit.

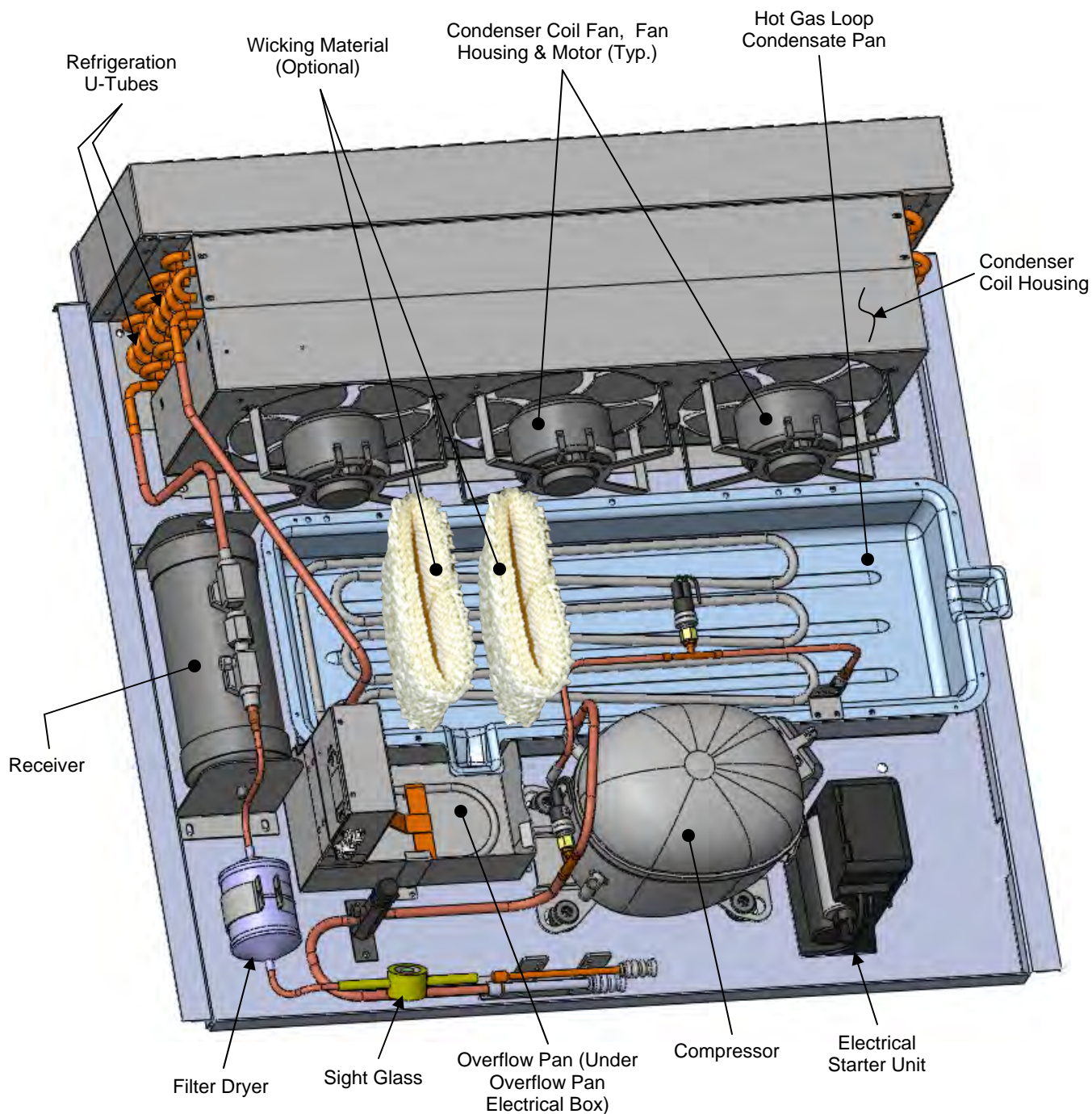

REFRIGERATION PACKAGE LAYOUT, CONT.: MODEL GCD856R SELF-CONTAINED UNIT

2. Refrigeration Package Layout, Continued

- Illustration shown reflects model GCD856R refrigeration package.
- **Note:** Due to design variables, refrigeration package components layout can slightly vary in location.
- Illustration below may not reflect every feature or option of your particular unit.

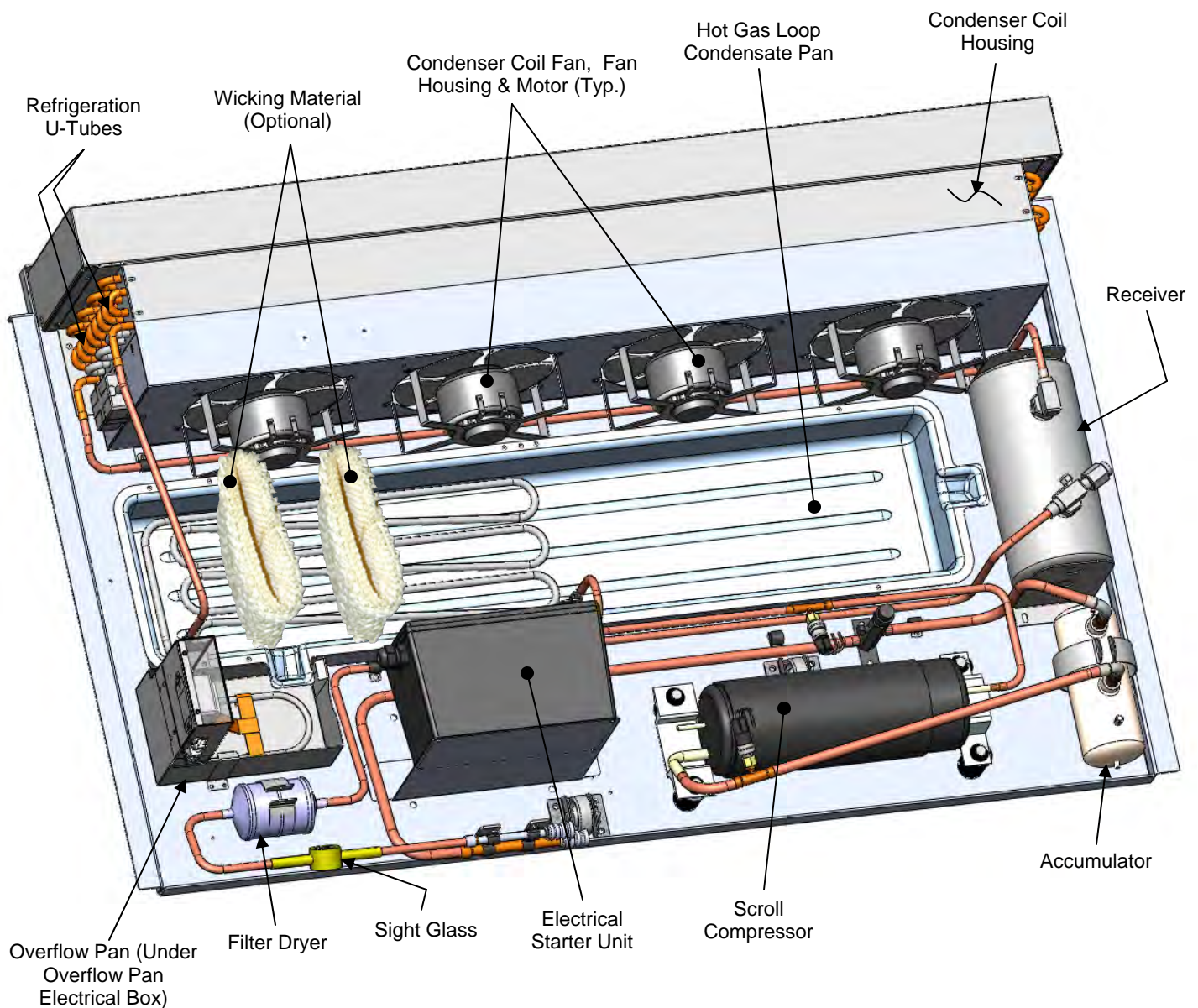

CLEANING SCHEDULE (INTERIOR) - TO BE PERFORMED BY TRAINED SERVICE PROVIDERS ONLY

AREA	FREQ.	INSTRUCTIONS
Interior	Quarterly	Upper Section Pans (With Ice) (Seafood Case) / Upper Section Aluminum Decking and Stainless Steel Pan (Meat Case): Remove from case. Submerge pans in hot water while using an anti-bacterial soap solution. Rinse thoroughly and dry. Ice must be new. Return to case.
	Quarterly	Upper Case Area: Wipe down upper section (including drain area) with hot water solution and anti-bacterial soap solution. Rinse thoroughly.
	Quarterly	Tub and Drain (Upper and Lower): Keep clean and free of debris which could clog tub and drain. <ul style="list-style-type: none"> • To access drain area, remove the decks and (for lower section) the fan shroud. • Direct the drain to a floor drain or a bucket. • Run hose into drain to flush out debris. Carefully hose out the tub. • Caution! Avoid splattering water over the case and surrounding areas!
	Quarterly	Air Return Grille and Fan Shroud Area: 1) Turn off power. 2) Remove decks from case. 3) Clean with moist cloth.
	Quarterly	Honeycomb Air Diffuser: See next page in this manual for cleaning instructions.
	Quarterly	Gravity Coil Tray Drip Assembly: Caution! Authorized personnel must approve and/or supervise this procedure! Turn off case. Lift rear sliding doors up and out from unit. See MAINTENANCE FUNDAMENTALS - REAR SLIDING DOORS section for instructions. Disconnect hose from hose connection spout (may require removal of hose clamp). Remove thumbscrews holding gravity coil tray drip assembly in place. Drop tray drip assembly downward. Lift 'lip' of gravity coil assembly up and off internal hook. Remove from unit. Submerge in hot water using an anti-bacterial soap solution. Rinse thoroughly and dry. Return to case. Reattach thumbscrews. Return rear sliding doors to case. Turn case back on. Note: Defrost timer MAY need to be reset. See illustrations below.

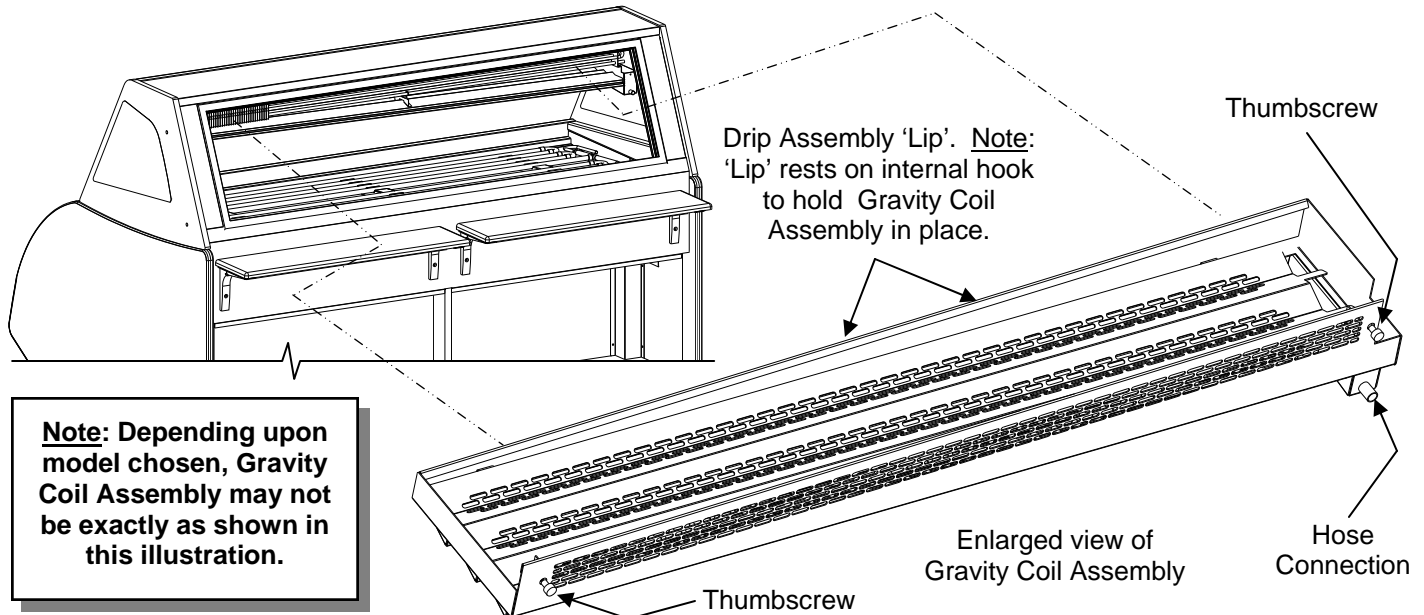

Preventive maintenance should be performed every 90 days unless conditions warrant a more frequent replacement cycle.

1. Honeycomb Air Diffuser Removal & Cleaning

- A. Wedge non-metallic device of suitable strength (such as a ballpoint pen) between honeycomb and end panel.
- Caution!** Use care not to dislodge the heating wire (that prevents condensation on the lamp assembly).
- B. Apply pressure to collapse the honeycomb to allow it to be pulled out of honeycomb retainer.
- C. Pry downward and away from honeycomb retainer.

Clean honeycomb with warm water and soap solution. Submerge if necessary. Use brush to dislodge stubborn or sticky residue. Dry by using vacuum's 'blow mode'.

2. Honeycomb Air Diffuser Installation

- D. Squeeze honeycomb into the honeycomb retainer.
- E. Carefully slide honeycomb into place.
- F. Adjust honeycomb so that it fits flat against retainer. Honeycomb must not be wavy or out of position.

Note: For honeycomb air diffusers in other locations, these same general instructions apply.

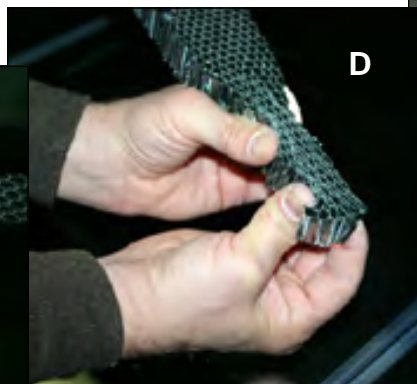
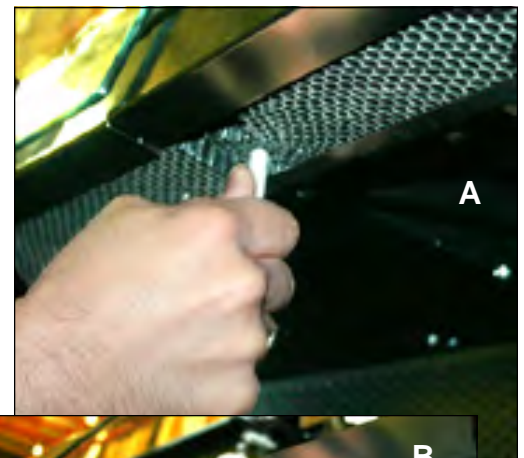
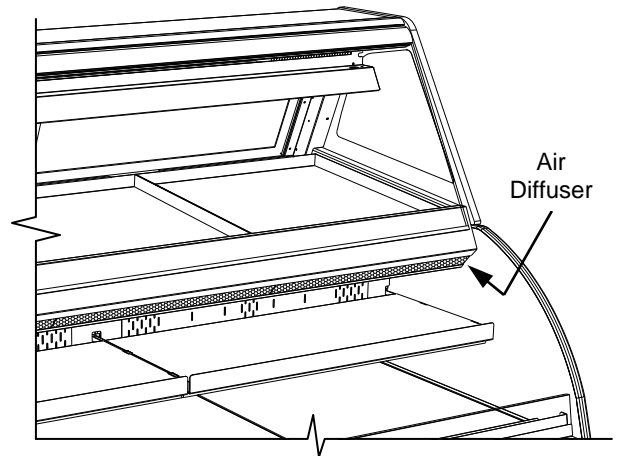

TROUBLESHOOTING - TO BE PERFORMED BY TRAINED SERVICE PROVIDERS ONLY

CONDITION	TROUBLESHOOTING
Water Is On The Floor	<p>Caution! Water on flooring can cause much damage! Until cause is determined (and repaired), following these procedures:</p> <ul style="list-style-type: none"> • Use wet-dry vacuum (or mop & bucket) to remove standing water. • Use 'catch pans' for water to drain into. Swap out regularly until case has completely drained.
	Check that the drain trap is free of debris.
	Check that the drain hose is correctly positioned over floor drain.
	Check store conditions. To prevent condensation in Type 1 environments, maximum conditions are to be 55% humidity / 75 °Fahrenheit. For Type 2 environments, maximum conditions are to be 60% humidity / 80 °Fahrenheit. See serial label (at case rear near main power switch) for Type of your case.
	Check that overflow evaporator pan is plugged in and operating properly.
	If unable to stop water from draining on floor, Contact Structural Concepts Technical Service. See telephone number on final page in this manual.
Fan Emits Excessive Noise	Check that the case is aligned, level and plumb.
	Check evaporator fan for cleanliness.
	Unplug fan motors; check motor shaft for excessive bearing wear.
	Check that fan motors are securely mounted in brackets.
	Verify that fan blades are securely mounted to fan motor.
	Check that nothing is preventing blade rotation.
	Check that the fan shroud is properly secured.

TROUBLESHOOTING, CONT. - TO BE PERFORMED BY TRAINED SERVICE PROVIDERS ONLY

CONDITION	TROUBLESHOOTING
Fans Are Not Working	Check that the MAIN power switch (if present) is on.
	Check that fans are plugged in to fan shroud.
	Check for foreign material obstructing fan performance.
	Check that fan blades freely rotate within fan shrouds.
	Check that power is going to fans.
	Check that fan wiring is connected on terminal blocks.
System Is Not Operating	Check that the utility power is on.
	Check the circuit breaker box for tripped circuits.
Case Is Not Holding Temperature	If a large amount of warm product was added to the case, it will take time for the temperature to adjust. Product should be pre-chilled before placing in display case.
	Check Carel® Temperature Controller section in this manual to confirm that proper settings are being maintained.
	Check that the case is not in the sun or near a heat or air conditioning vent.
	Check that case is not located near outside doors: ambient temperature fluctuation can hinder unit's ability to maintain proper case temperature.
	Check Set Point Temperature; it may be adjusted too high.

TROUBLESHOOTING, CONT. (CONDENSATE SYSTEM) - PERFORMED BY TRAINED SVC PROVIDERS

CONDITION	TROUBLESHOOTING
Low Suction Pressure	Check for low refrigerant.
	Check that Expansion Valve isn't restricted.
	Check that Liquid Line or Filter isn't restricted.
	Check that Evaporator Motors are working.
	Check for Superheat setting.
	Check that the Thermostatic Element charge isn't depleted.
	Check that the Coil is not iced up.
High Suction Pressure	Check that Refrigerant Charge isn't too high.
	Check that Compressor Valves aren't faulty.
	Check that there is no air seepage around Condensing Coil.
	Check that the Cooling Load isn't high.
	Check that Superheat adjustment isn't low.
	Check TXV Bulb Installation a. Poor thermal contact. b. Warm location.
	Check Compressor: Low capacity means it is undersized for its application.

PREVENTIVE MAINTENANCE - TO BE PERFORMED BY TRAINED SERVICE PROVIDERS ONLY

WARNING! TURN OFF CASE BEFORE PERFORMING PREVENTIVE MAINTENANCE!

PREVENTIVE MAINTENANCE	FREQ.	INSTRUCTIONS
Case Exterior	Quarterly	<p><u>Condensing Coil (Self-Contained Units Only):</u></p> <ul style="list-style-type: none"> • Remove rear grille (by lifting up and off). • Use air pressure or industrial strength vacuum; clean dust and dirt that may collect on the Condenser Coil. • Caution! Coil fins are sharp. Handle with care! • Replace rear grille to case.
	Quarterly	<p><u>Refrigeration Package/Compressor Area (Self Contained Units Only):</u> <i>Caution! Be certain to disconnect power from case before cleaning refrigeration package!</i></p> <ul style="list-style-type: none"> • <i>Warning! Condensate Pan Is HOT! Disconnect power from case and allow to cool before cleaning pan!</i> • Slide/Roll compressor package out from under case. • See REFRIGERATION FUNDAMENTALS section for in-depth instructions on accessing the evaporator pan. • Use a scrub-brush and a de-scaling solution such as CLR® (to prevent corrosion, lime and rust). Follow instructions as to proper dilution, safety precautions and scrubbing method. • After thoroughly cleaning pan with scrub-brush and solution, rinse thoroughly with clean water (in spray bottle) and wipe dry with sponge or paper towel. • Use moist cloth to wipe off dust & debris that collects on various parts (fans, sight glass, overflow pan, etc.). • Slide refrigeration assembly back under case. • Replace front panel and lower grille via hooks (no screws required).
	Quarterly	<p><u>Under Case Cleaning:</u> Once refrigeration package is clear of unit, vacuum under case to remove all dust and dirt that may collect under case.</p>
Case Interior	Quarterly	<p><u>Tub, Coil, Drain, Fan Blades, Motors, Brackets:</u> <i>Disconnect power from the case before cleaning the Tub, Coil, Fan, Motor and Drain Area!</i></p> <ul style="list-style-type: none"> • Remove Decking, Sub-Deck and Fan Shroud. • Use vacuum to clean Evaporator Coils. • Clean Tub, Coil and Drain with warm water, clean cloth, brush and mild soap solution. • Remove any debris that may clog drain. • Clean Fan Blades, Motors and Brackets by wiping down with moist cloth.
	Quarterly	<p><u>Honeycomb:</u> Check honeycomb air diffuser to determine whether it is dirty. If dirty, remove from case. See PREVENTIVE MAINTENANCE: HONEYCOMB AIR DIFFUSERS (TRAINED SERVICE PROVIDERS ONLY) section of this manual (next page) for cleaning specifics.</p>

MAINTENANCE - FRONT GLASS ALIGNMENT & ADJUSTMENT VIA CLAMSHELL ALLEN SCREWS

1. Front Glass Alignment & Adjustment via Clamshell Allen Screw Adjustment

Caution! Glass is extremely heavy! Two people may be required to perform this task.

- Make certain case is level and plumb.
- Lift glass to maximum upright position.

- Determine which side requires realignment.
- While maintaining tight grip on glass, loosen the Allen screws nearest to misaligned side.
- Adjust the glass until properly positioned.
- Allen screws may now be tightened (taut, but not overly tightened lest glass breakage occur).
- If other side needs alignment, repeat steps while maintaining grip on glass.

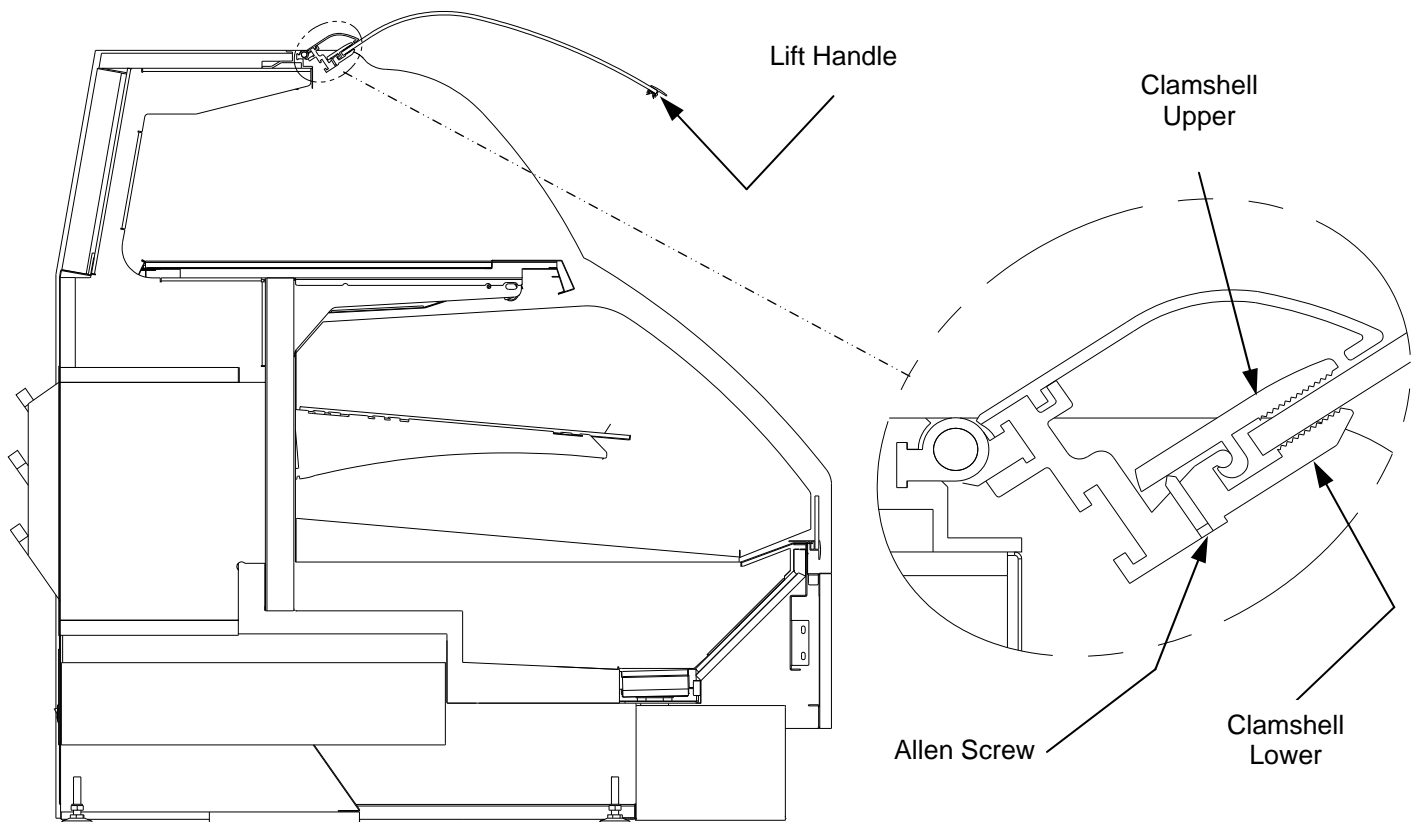

Note: Above Illustration May Not Depict An Exact Representation Of Your Particular Unit Being Installed.

2. Front Glass Alignment & Adjustment via Frame Support Rails

- Proper alignment of the front glass is important to maintain a seal inside case.
- Improper alignment can cause air leaks compromising the environment inside the case and create condensation.
- Follow the five steps listed below to assure proper front glass alignment.
- Illustrations shown may not exactly reflect every feature or option of your case.

Note: Illustrations Shown May Not Depict An Exact Representation Of Your Particular Unit

1. **Side-to-Side Leveling:** Place a level on top of display case (parallel to front glass). Level the case by inserting shims under the rails. Follow steps 3 and 4 below for specifics.

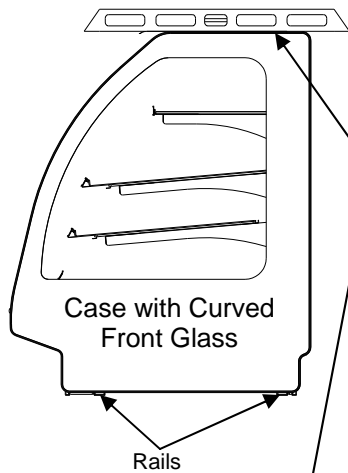
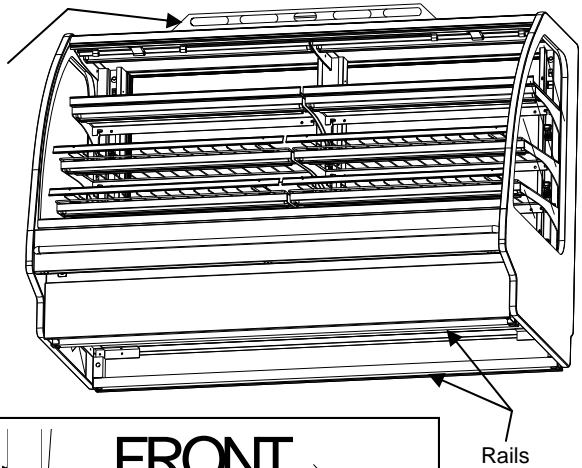

2. **Front-to-Back Leveling:**
- Place a level on top of case, perpendicular to the front glass.
 - Raise or lower either side of case by shimming under the rails (following steps 3 & 4 below).
 - Double-check the side-to-side level.

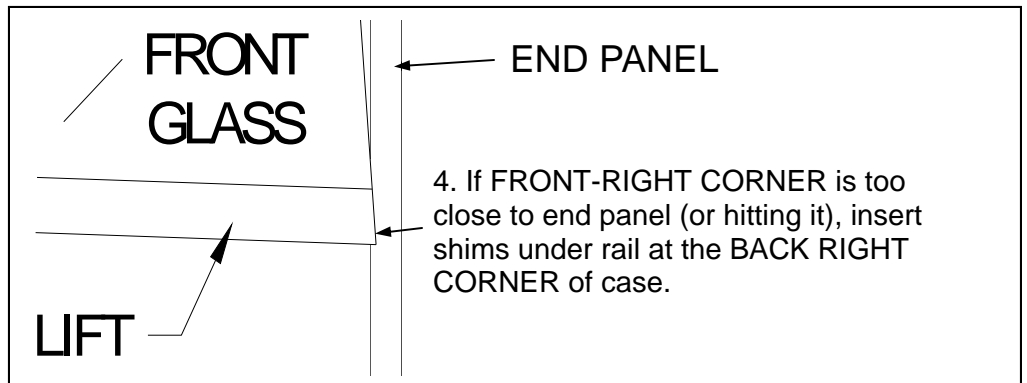
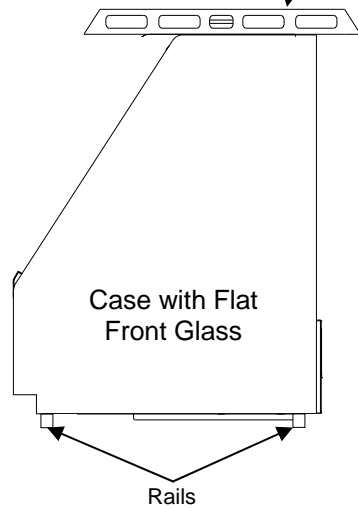
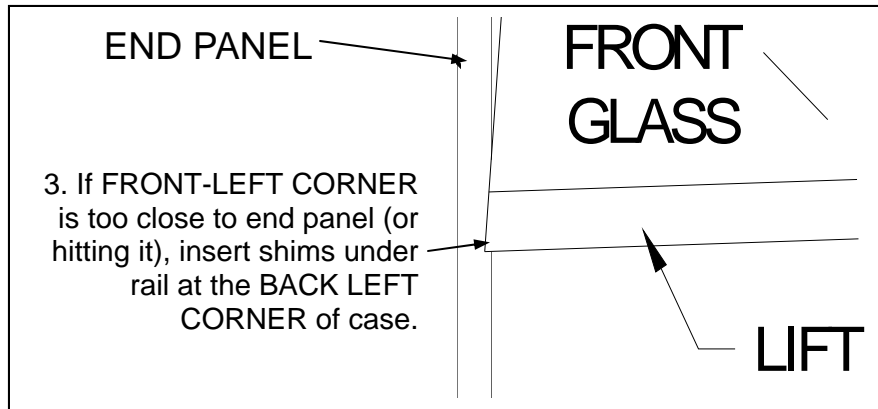

5. Verification:

- After inserting shims, open and shut the front glass.
- Verify (again) that the front glass is properly aligned at both left-hand and right-hand side of the case.
- If not, repeat shimming procedure until the front glass is properly aligned along both sides of the case.

3. Front Glass Alignment & Adjustment via Levelers

Setting The Case With Levelers:

Note: Below illustrations may not exactly reflect every feature or option of your particular case.

- **Illustration #1, at top-right** shows pry bar, adjustable wrench and various leveler styles.
- Begin with all feet touching the floor, so that the Case does not wobble when the Curved Front Glass is closed.
- Side-to-side: Place a level on top of display case (parallel to the front glass). Raise or lower either side of the case by rotating the levelers to center the level bubble. **See illustration #2, below left.**
- Front-to-back: Place a level on top of the case, perpendicular to the front glass, and follow the same procedure. **See illustration #3, below right.**
- Double-check the level again, side-to-side.
- The Curved Front Glass should be evenly spaced (approximately 1/8") from the sides of the case. **See illustration #4a & 4b, on next page.**
- If Curved Front Glass is NOT properly aligned, continue with Alignment instructions, on next page. **See illustration #5a & 5b, on next page.**

After Case is properly positioned, raise (or lower) levelers with adjustable wrench.

- Turn levelers COUNTER-CLOCKWISE to lower.
- Turn levelers CLOCKWISE to raise.
- Note: Leveler illustrations may not reflect every style, feature or option of your particular case.

1. Pry Bar, Adjustable Wrench, and Various Leveler Styles

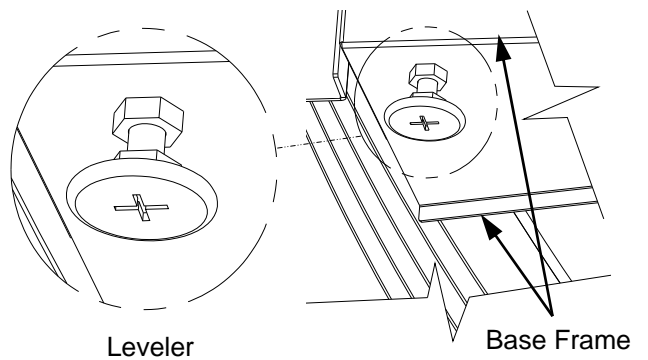
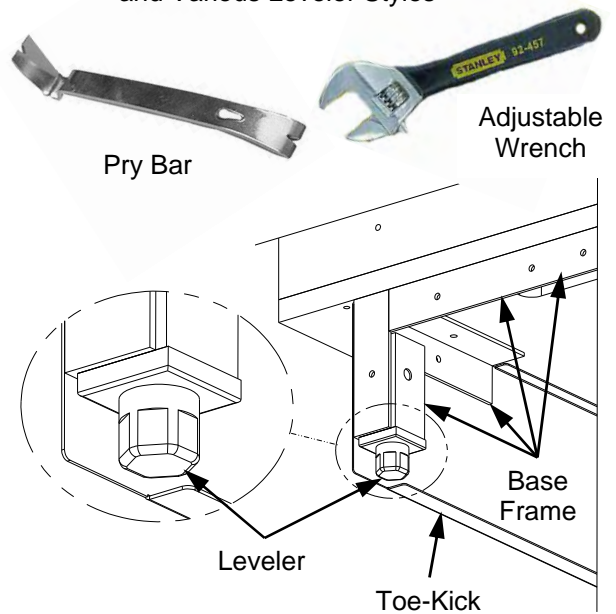

2. Case Front View With Level at top

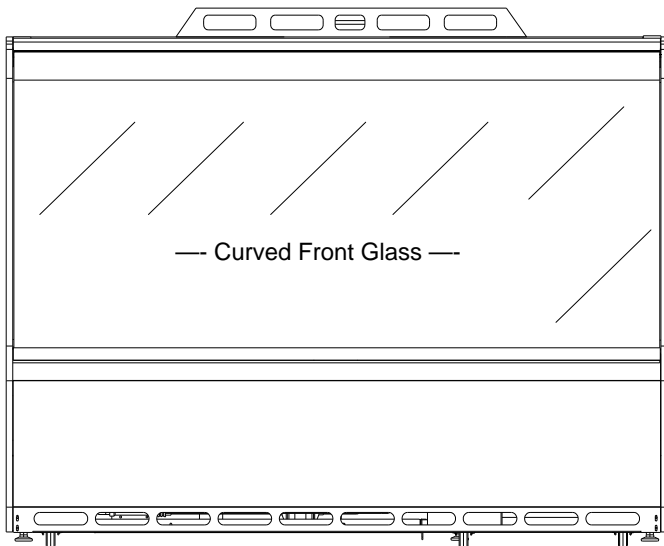

3. Case Side View With Level at top

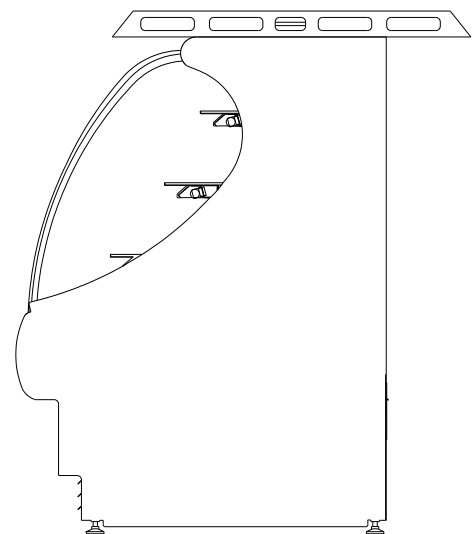

4. Front Glass Alignment & Adjustment via Levelers, Continued

Note: Below illustrations may not exactly reflect every feature or option of your particular case.

- Proper alignment of the Curved Front Glass is vitally important to create and maintain a seal inside the Case. Air leaks caused by improper alignment will compromise the environment inside the case, and may create condensation.
- If the FRONT-LEFT CORNER of the glass is too close to the end panel (or hitting it), the leveler at the BACK LEFT CORNER must be adjusted. **See illustration #5a, at lower left.** Adjust the leveler one full revolution (360°) CLOCKWISE. This action will raise the left-rear case area, thereby increasing distance between the customer-left corner of the glass and its end panel.
- If the FRONT-RIGHT CORNER of the glass is too close to the end panel (or hitting it), the leveler at the BACK RIGHT CORNER must be adjusted. **See illustration #5b, at lower right.** Adjust the leveler one full revolution (360°) CLOCKWISE. This action will raise the right-rear cabinet area, thereby increasing the distance between the customer-right corner of the glass and its end panel.
- After adjusting the levelers, open and shut the front glass and check again to see if the curved front glass is properly aligned: It is to be evenly spaced (approximately 1/8") from both sides of the case.

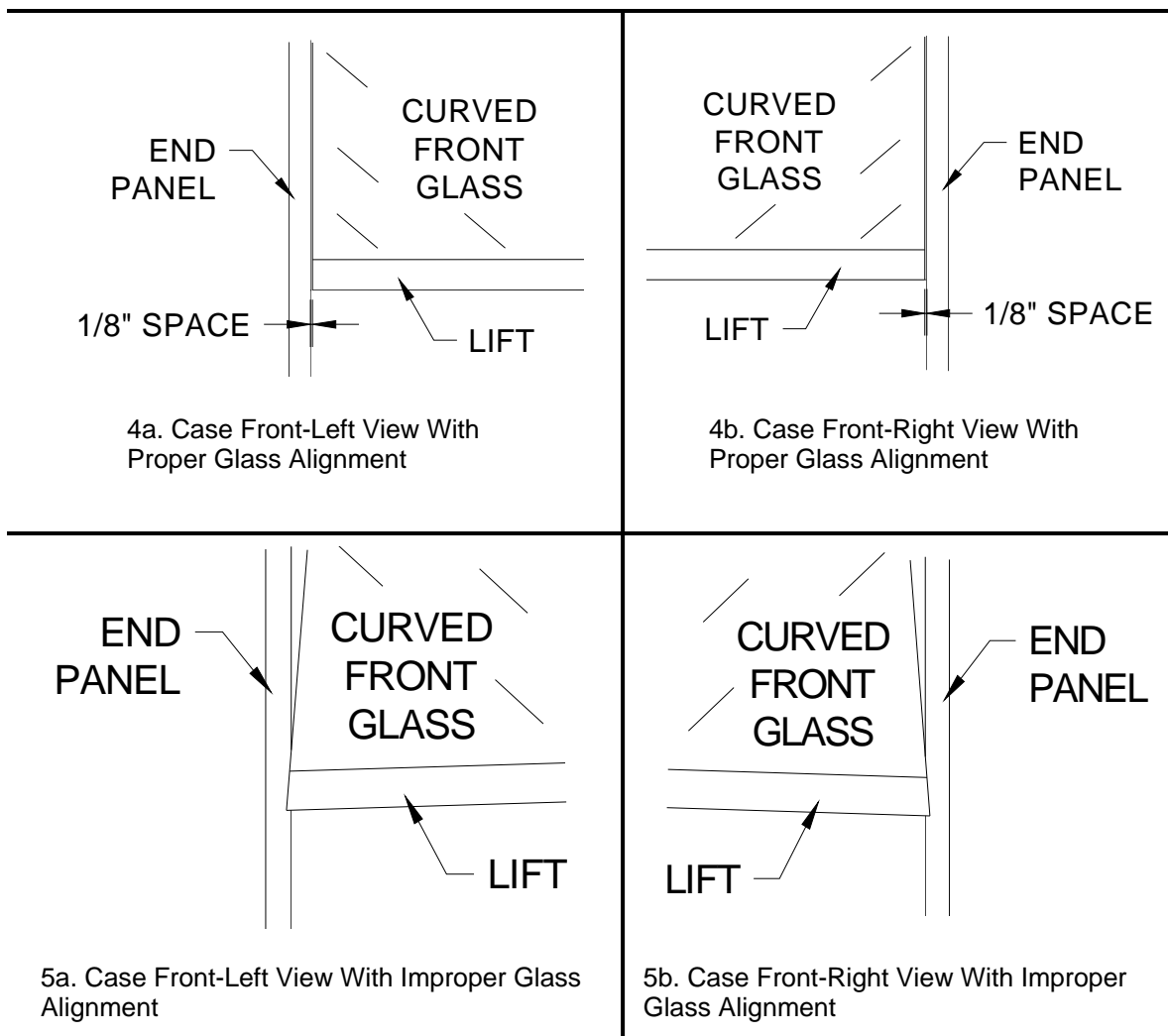

**GENERAL TECHNICAL
INFORMATION
(PARTS LIST / SERIAL
LABEL INFO /
TEMPERATURE
CONTROLLER
INFORMATION /
TECHNICAL SERVICE
INFORMATION), ETC.**

Serial Label Location & Information Listed / Technical Information & Service

- Serial labels are located near the electrical access on your case.
- Serial labels contain electrical, temperature & refrigeration information, as well as regulatory standards to which the case conforms.
- For additional technical information and service, see the *TECHNICAL SERVICE* page in this manual for instructions on contacting Structural Concepts' Technical Service Department.
- See images below for samples of both refrigerated and non-refrigerated serial labels.

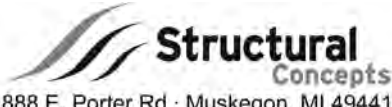



888 E. Porter Rd · Muskegon, MI 49441

ENCORE[®] MODEL HV74RSS SCROLL
SERIES SERIAL NO.

FOR PARTS AND SERVICE
CALL 1-800-433-9489

SAMPLE ONLY

  3048256 CONFORMS TO UL STD 471 CONFORMS TO NSF STD 7 CERTIFIED TO CAN/CSA STD C22.2 NO 120	ELECTRICAL RATING REFRIGERANT DESIGN PRESSURE MINIMUM CIRCUIT MAXIMUM OVERCURRENT	120/1/60 24A R404A AMOUNT ?? OZ HIGH 450 LOW 200 30A 30A
-------------------------------------------------------------------------------------------------------------------------------------------------------------------------------------------------------------------------------------------------------------------------------	-----------------------------------------------------------------------------------------------	----------------------------------------------------------------------

SAMPLE ONLY

Super Heat Temp	8-10°F
BTUH Requirements	9,738 BTUH @ 20° F SST
Defrost	6 defrosts per day, 45° F termination, 45 min. failsafe

SAMPLE ONLY

----- Sample Serial Label For Refrigerated Case -----



888 E. Porter Rd · Muskegon, MI 49441

Addenda[®] PC5682 txtRemote
txtSerialNumber

120 VOLTS 60 HZ SINGLE PHASE 1.84AMP

FOR PARTS OR SERVICE CALL
STRUCTURAL CONCEPTS
AT
1-800-433-9489

SAMPLE ONLY

|||

|||

3048256
CONFORMS TO UL STD 65
CERTIFIED TO CAN/CSA
STD C22.2 NO 120

----- Sample Serial Label For Non-Refrigerated Case -----

CAREL

ir33 platform

Integrated Electronic
Microprocessor Controller



Programming The Instrument

To Modify The Setpoint

Set Press and hold the "SET" key for at least 1 second.

▲ / aux **def** 2. Use arrow keys ▲ ▼ on temperature controller to increase (or decrease) the setpoint.

Set 3. Quickly press and release the "SET" key again.

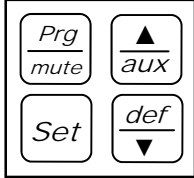

To Modify Defrost, Differential, Other Parameters

Prg / mute **Set** 1. Press & hold "Prg" & "SET" keys together for five (5) seconds; display will flash "0", representing password prompt.

Set 2. Confirm by pressing "SET" key.

▲ / aux **def** 3. Press ▲ or ▼ to reach the category to be modified.

Set 4. Press "SET" to modify this selected parameter.

▲ / aux **def** 5. Increase or decrease the value using the ▲ or ▼ button respectively.

Set 6. Press the "SET" key to temporarily save the new value and return to the display of the parameter.

Prg / mute 7. Press & hold the "Prg" key for at least 5 seconds to save changes. This action will also mute the audible alarm (buzzer) & deactivate the alarm relay.

How To Change Reading From Fahrenheit (°F) To Celsius (°C)

Prg / mute **Set** 1. Press and hold "Prg" and "SET" keys together for at least 5 seconds; display will show "0" (password prompt).

Set 2. Confirm by pressing "SET" key.

▲ / aux **def** 3. Press ▲ or ▼ until reaching the parameter "/ 5".

Set 4. Press "SET" to modify this selected parameter.

▲ / aux **def** 5. Press ▲ or ▼ to change value to desired setting: "0" for Celsius (°C) or "1" for Fahrenheit (°F).

Set 6. Press "SET" key to temporarily save the new value and return to the display of the parameter.

Prg / mute 7. Press & hold "Prg" key for at least 5 seconds to save changes. **Note! All values will automatically convert to new scale. No conversion is required.**

Warning! Save Your Parameter Settings!

1. To store the new parameter values, PRESS and HOLD the "Prg" key for at least 5 seconds.
2. All modifications made to parameters will be lost if you do NOT press a button within 60 seconds. Should this "timeout" occur, normal operational settings (prior to modifications being made) will resume.
3. If the instrument is switched off before pressing the "Prg" key, all modifications to parameters will be lost.

def **To Activate Manual Defrost**
Press and hold "def" key for at least 5 seconds.

▲ / aux **To Activate / Deactivate Auxiliary Output**
Press and hold the "aux" key for 1 second.

Prg / mute **▲ / aux** **To Reset Any Alarms With Manual Reset**
Press and hold the "Prg" and "aux" key for at least 1 second.

CAREL

ir33 platform
**Integrated Electronic
 Microprocessor Controller**



User Interface - Display

ICON	FUNCTION	DESCRIPTION	Normal operation			Start up
			ON	OFF	BLINK	
	COMPRESSOR	ON when the compressor starts. Flashes when the activation of the compressor is delayed by safety times.	Compressor on	Compressor off	awaiting activation	
	FAN	ON when the fan starts. Flashes when the activation of the fan is prevented due to external disabling or procedures in progress.	Fan on	Fan off	awaiting activation	
	DEFROST	ON when the defrost is activated. Flashes when the activation of the defrost is prevented due to external disabling or procedures in progress.	Defrost in progress	Defrost not in progress	awaiting activation	
	AUX	Flashes if the anti-sweat heater function is active, ON when the auxiliary output (1 and/or 2) selected as AUX (or LIGHT in firmware version 3.6) is activated.	AUX auxiliary output active (version 3.6 light auxiliary output active)	AUX auxiliary output not active	Anti-sweat heater function active	
	ALARM	ON following pre-activation of the delayed external digital input alarm. Flashes in the event of alarms during normal operation (e.g. high/low temperature) or in the event of alarms from an immediate or delayed external digital input.	Delayed external alarm (before the time 'A7' elapses)	No alarm present	Alarms in norm. operation (e.g. High/low temperature) or immediate or delayed alarm from external digital input	
	CLOCK	ON if at least one timed defrost has been set. At start-up, comes ON for a few seconds to indicate that the Real Time Clock is fitted.	If at least 1 timed defrost event has been set	No timed defrost event set	Alarm clock	ON if real-time clock present
	LIGHT	Flashes if the anti-sweat heater function is active, ON when the auxiliary output (1 and/or 2) selected as LIGHT is activated (in firmware version 3.6 it does not flash in anti-sweat heater mode and comes on when the dead band output is active).	Light auxiliary output on (version 3.6 dead band auxiliary output active)	Light auxiliary output off	Anti-sweat heater function active (version 3.6 does not flash in anti-sweat heater mode)	
	SERVICE	Flashes in the event of malfunctions, for example E2PROM errors or probe faults.		No malfunction	Malfunction (e.g. E2PROM error or probe fault). Contact service	
	CONTINUOUS CYCLE	ON when the CONTINUOUS CYCLE function is activated. Flashes if the activation of the function is prevented due to external disabling or procedures in progress (E.g.: minimum compressor OFF time).	CONTINUOUS CYCLE operation activated	CONTINUOUS CYCLE function not activated	CONTINUOUS CYCLE operation requested	

Summary Table of Alarm and Signals: Display, Buzzer and Relay

Code	Icon on the display	Alarm relay	Buzzer	Reset	Description
rE	flashing	on	on	automatic	virtual control probe fault
E0	flashing	off	off	automatic	room probe S1 fault
E1	flashing	off	off	automatic	defrost probe S2 fault
E2	flashing	off	off	automatic	probe S3 fault
E3	flashing	off	off	automatic	probe S4 fault
E4	flashing	off	off	automatic	probe S5 fault
	No	off	off	automatic	probe not enabled
LO	flashing	on	on	automatic	low temperature alarm
HI	flashing	on	on	automatic	high temperature alarm
AFr	flashing	on	on	manual	antifreeze alarm
IA	flashing	on	on	automatic	immediate alarm from external contact
dA	flashing	on	on	automatic	delayed alarm from external contact
dEF	on	off	off	automatic	defrost running
Ed1	No	off	off	automatic/manual	defrost on evaporator 1 ended by timeout
Ed2	No	off	off	automatic/manual	defrost on evaporator 2 ended by timeout
Pd	flashing	on	on	automatic/manual	maximum pump down time alarm
LP	flashing	on	on	automatic/manual	low pressure alarm
AtS	flashing	on	on	automatic/manual	autostart in pump down
cht	No	off	off	automatic/manual	high condenser temperature pre-alarm
CHT	flashing	on	on	manual	high condenser temperature alarm
dor	flashing	on	on	automatic	door open too long alarm
EE	flashing	off	off	automatic	E2prom error, unit parameters
EF	flashing	off	off	automatic	E2prom error, operating parameters
ccb	Signal				start continuous cycle request
ccE	Signal				end continuous cycle request
dFb	Signal				start defrost call
dFE	Signal				end defrost call
On	Signal				switch ON
off	Signal				switch OFF
rES	Signal				reset alarms w/manual reset / reset HACCP alarms / reset temp. monitoring

CAREL

ir33 platform

Integrated Electronic
Microprocessor Controller



Summary Table of Operating Parameters

CODE	PARAMETER	UOM*	TYPE	MINIMUM	MAXIMUM	DEFAULT
/5	Select Celsius (°C) or Fahrenheit (°F)	flag	C	0	1	For Case Specific Defaults See Serial Label Located Near Electrical Access On Your Case. For Additional Technical Information Call Structural Concepts Technical Service Dept. at 1(800) 433.9489
/c1	Calibration of probe 1	°C/°F	C	-20	20	
/c2	Calibration of probe 2	°C/°F	C	-20	20	
St	Temperature set point	°C/°F	F	r2	r1	
rd	Control delta	°C/°F	F	20	0.1	
dl	Interval between defrosts	hours	F	0	250	
dt1	End defrost temperature, evaporator	°C/°F	F	-50	200	
dP1	Maximum defrost duration, evaporator	min	F	1	250	
d6	Display on hold during defrost	-	C	0	2	
dd	Dripping time after defrost	min	F	0	15	
d/1	Display of defrost probe 1	°C/°F	F	-	-	

* Unit Of Measure

STRUCTURAL CONCEPTS CORPORATION TECHNICAL SERVICE
PHONE NUMBER: 1.800.433.9489 or For Your Master Service Agent See
WWW.STRUCTURALCONCEPTS.COM/Contact/Master_Service_Agents.asp

LIMITED WARRANTY

All sales by Structural Concepts Corporation (SCC) are subject to the following limited warranty. "Goods" refers to the product or products being sold by SCC.

Warranty Scope: Warranty is for equipment sold in the United States, Canada, Mexico and Puerto Rico. Equipment sold elsewhere may carry modified warranty.

Warranty; Remedies; Limitations. SCC warrants that if any Goods are found by an authorized representative of SCC not to be of good material or workmanship within one year of the date of shipments SCC will, at its option after inspection by an authorized representative, replace any defective Good or pay the reasonable cost of replacement for any such defective Goods, provided that written notice of the defect is given to SCC within 30 days of the appearance of such defect. If notice is not given within such period, any claim for breach of warranty shall be conclusively deemed to have been waived and SCC shall not be liable under this warranty. If SCC is unable to repair or replace the defective Goods, SCC shall issue a credit to the Purchaser for all or part of the purchase price, as SCC shall determine. The replacement or payment in the manner described above shall be the sole and exclusive remedy of Purchaser for a breach of this warranty. If any Goods are defective or fail to conform to this warranty, SCC will furnish instructions for their disposition. No Goods shall be returned to SCC without its prior consent.

SCC's liability for any defect in the Goods shall not exceed the purchase price of the Goods. SCC SHALL HAVE NO LIABILITY TO PURCHASE FOR CONSEQUENTIAL DAMAGES OF ANY KIND WHATSOEVER, INCLUDING, BUT NOT LIMITED TO, PERSONAL INJURY, PROPERTY DAMAGE, LOST PROFITS, OR OTHER ECONOMIC INJURY DUE TO ANY DEFECT IN THE GOODS OR ANY BREACH OF SCC, SCC SHALL NOT BE LIABLE TO THE PURCHASER IN TORT FOR ANY NEGLIGENT DESIGN OR MANUFACTURE OF THE GOODS, OR FOR THE OMISSION OF ANY WARNING THEREFROM.

SCC shall have no obligation or liability under this warranty for claims arising from any other party's (including Purchaser's) negligence or misuse of the Goods or environmental conditions. This warranty does not apply to any claim or damage arising for or cause by improper storage, handling, installation, maintenance, or from fire, flood, accidents, structural defects, building settlement or movement, acts of God, or other causes beyond SCC's control.

Except as expressly stated herein, SCC makes no warranty, express, implied, statutory or otherwise as to any parts or goods not manufactured by SCC. SCC shall warrant such parts or Goods only (I) against such defects, (II) for such periods of time, and (III) with such remedies, as are expressly warranted by the manufacturer of such parts of Goods. Notwithstanding the foregoing, any warranty with respect to such parts of Goods and any remedies available as a result of a breach thereof shall be subject to all of the procedures, limitations, and exclusions set forth herein.

THE WARRANTIES HEREIN ARE IN LIEU OF ALL WARRANTIES, EXPRESS, IMPLIED, STATUTORY, OR OTHERWISE. IN PARTICULAR, SCC MAKES NO WARRANTY OF MERCHANTABILITY OR FITNESS FOR A PARTICULAR PURPOSE.

No representative, agent or dealer of SCC has authority to modify, expand, or extend this Warranty, to waive any of the limitations or exclusions, or to make any different or additional warranties with respect to Goods.

Period of Limitations. No claim, suit or other proceeding may be brought by Purchaser for any breach of the foregoing warranty or this Agreement by SCC or in any way arising out of this Agreement or relating to the Goods after one year from the date of the breach. In the interpretation of this limitation on action for a breach by SCC, it is expressly agreed that there are no warranties of future performance of the goods that would extend that period of limitation herein contained for bringing an action.

Indemnifications. Purchaser agrees to indemnify, hold harmless, and defend SCC if so requested, from any and all liabilities, as defined herein, suffered, or incurred by SCC as a result of, or in connection with, any act, omission, or use of the Goods by Purchaser, its employees or customers, or any breach of this Agreement by Purchaser. Liabilities shall include all costs, claims, damages, judgments, and expenses (including reasonable attorney fees and costs).

Remedies of SCC. SCC's rights and remedies shall be cumulative and may be exercised from time to time. In a proceeding or action relating to the breach of this Agreement by Purchaser, Purchaser shall reimburse SCC for reasonable costs and attorney's fees incurred by SCC. No waiver by SCC of any breach of Purchaser shall be effective unless in writing nor operate as a waiver of any other breach of the same term thereafter. SCC shall not lose any right because it has not exercised it in the past.

Applicable Law. This Agreement is made in Michigan and shall be governed by and interpreted according to Michigan law. Any lawsuit arising out of this Agreement or the Goods may be handled by a federal or state court whose district includes Muskegon County, Michigan, and Purchaser consents that such court shall have personal jurisdiction over Purchaser.

Miscellaneous. If any provision of this Agreement is found to be invalid or unenforceable under any law, the provision shall be ineffective to that extent and for the duration of the illegality, but the remaining provisions shall be unaffected. Purchaser shall not assign any of its rights nor delegate any of its obligations under this Agreement without prior written of SCC. This Agreement shall be binding upon and inure to the benefit of SCC and Purchaser and each of their legal representatives, successors and assigns.

SCC warrants its products to be free of defects in materials and workmanship under normal use and service for a period of one (1) year from the date of delivery.

This warranty is extended only to the original purchaser for use of the Goods. It does not cover normal wear parts such as plastic tongs, tong holders, tong cables, bag holders, or acrylic dividers.

General Conditions. All service labor and/or parts charges are subject to approval by SCC. Contact the Customer Service Department in writing or call 231-798-8888.

All claims must contain the following information: (1) model & serial code number of equipment; (2) the date and place of installation; (3) the name and address of the agency which performed the installation; (4) the date of the equipment failure; and (5) a complete description of the equipment failure and all circumstances relating to that failure.

Once the claim has been determined to be a true warranty claim by SCC's Customer Service Department, the following procedure will be taken: (1) replacement parts will be sent at no charge from SCC on a freight prepaid basis; (2) reimbursement for service labor will be paid if the following conditions have been met - (a) prior approval of service agency was awarded from the Customer Service Department; and (b) an itemized statement of all labor charges incurred is received by the Customer Service Department. The cost of the service labor reimbursement will be based on straight time rates and reasonable time for the repair of the defect.

If problems occur with any compressor, notify SCC's Customer Service Department immediately. Any attempt to repair or alter the unit without prior consent from the Customer Service Department will render any warranty claim null and void. This warranty and protection plan does not apply to any condensing unit or any part thereof which has been subject to accident, negligence, misuse, or abuse, or which has not been operated in accordance with the manufacturer's recommendations or if the serial number of the unit has been altered, defaced, or removed.

Limit of Liability. The limit of liability of SCC toward the exchange cost of the original condensing unit, F.O.B. SCC, Norton Shores, MI, of each motor-compressor assembly replaced during the warranty shall not exceed manufacturer's current established wholesaler's exchange price and in no case shall the labor of removing or replacing the motor-compressor or parts thereof be the responsibility of SCC.