

G-SERIES

INSTALLATION AND OPERATING MANUAL

PN 5-9410

- > G-SERIES SERVICE REFRIGERATED DELI MERCHANDISERS (BOTH REMOTE & SELF-CONTAINED UNITS)
- > **PLEASE NOTE:** CASES SHOWN REFLECT FULL OR OPEN END PANELS. EACH CASE VARIES.

Model GMDSES8R
End Panel Removed /
Optional Case-To-Case Glass /
Front & Rear Shelves /
Variety of Product Steps

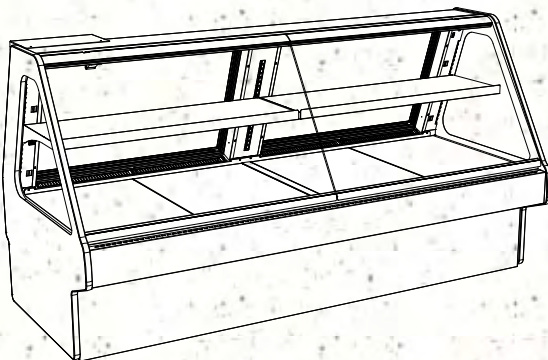
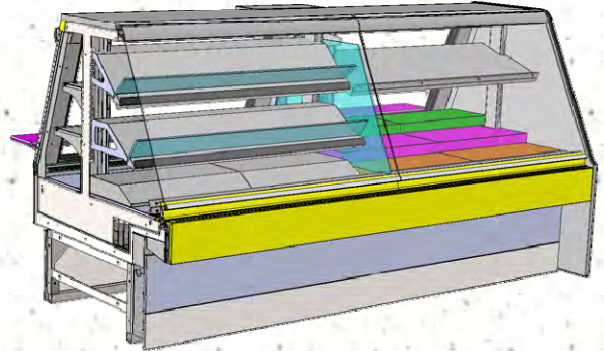

Model GMDS8R - With Optional Scale Stand and Without Rear Sliding Doors



Model GMDS6R With Rear Sliding Doors

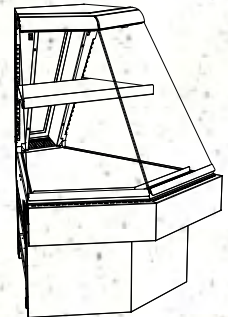

Model GMDSX4R



GMDS4R With Rear Sliding Doors

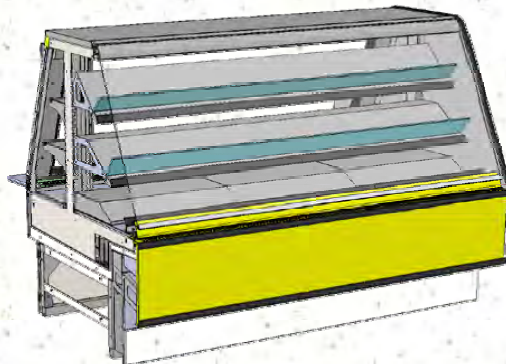

Model GMDSES6R / End Panel Removed / Front & Rear Shelves / Variety of Product Steps

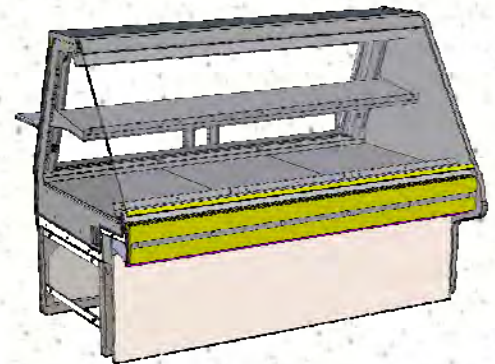

GMDS6R.5773D Without Rear Sliding Doors

Model GMDS4R.....	48 3/4"L* x 42 3/4"D^ x 51 5/8"H	Model GMDS8R.5243A.....	99 3/4"L* x 42 3/4"D^ x 51 5/8"H
Model GMDS4R.5068.....	48 3/4"L* x 42 3/4"D^ x 51 5/8"H	Model GMDSES8R.....	99 3/4"L* x 42 3/4"D^ x 51 5/8"H
Model GMDS5R.....	62 3/4"L* x 42 3/4"D^ x 51 5/8"H	Model GMDS10R.....	123 3/8"L* x 42 3/4"D^ x 51 5/8"H
Model GMDS6R.....	71 3/8"L* x 42 3/4"D^ x 51 5/8"H	Model GMDS10R.5243.....	123 3/8"L* x 42 3/4"D^ x 51 5/8"H
Model GMDS6R.5241.....	71 3/8"L* x 42 3/4"D^ x 51 5/8"H	Model GMDS12R.....	148 1/2"L* x 42 3/4"D^ x 51 5/8"H
Model GMDSES6R.....	75 3/8"L* x 44 1/2"D~ x 51 3/8"H	Model GMDS12R.5241A.....	148 1/2"L* x 42 3/4"D^ x 51 5/8"H
Model GMDS8R.....	99 3/4"L* x 42 3/4"D^ x 51 5/8"H	Model GMDSES12R.....	148 1/2"L* x 42 3/4"D^ x 51 5/8"H
Model GMDS8R.5182.....	99 3/4"L* x 42 3/4"D^ x 51 5/8"H	Model GMSX4R.....	39 1/8"L* x 41 1/4"D x 51 3/8"H

* End Panels Included (Will Not Apply To Lineups) ^49 5/8 Deep With Optional Rear Wrapping Board Raised
~ 51 3/8 Deep With Optional Rear Wrapping Board Raised



TABLE OF CONTENTS / LIST OF MODELS INCLUDED IN MANUAL

TABLE OF CONTENTS / LIST OF MODELS ENCOMPASSED IN MANUAL	2
OVERVIEW / TYPE / COMPLIANCE / WARNINGS / PRECAUTIONS / WIRING	3-4
INSTALLATION: REMOVAL FROM SKID, REMOVING LOWER FRONT PANELS	5
INSTALLATION, CONT'D: BOLTING AND CAULKING UNITS TOGETHER	6
INSTALLATION, CONT'D: FRAME SUPPORT RAIL SHIMMING	7
INSTALLATION, CONT'D: FRONT GLASS ALIGNMENT & ADJUSTMENT (VIA RAIL SYSTEM)	8
INSTALLATION, CONT'D: PROBE LEADS BOX / FIELD WIRING BOX / BALLAST (OR OPTIONAL LED DRIVER) / ANTI-CONDENSATE AXIAL FANS	9
INSTALLATION, CONT'D: REFRIGERATION LINES / STUB-UPS / DRAINS	10
START-UP AND OPERATION	11
MAINTENANCE FUNDAMENTALS: STANDARD LIGHT FIXTURES	12
MAINTENANCE FUNDAMENTALS, CONT'D: SHELF ASSEMBLIES	13
MAINTENANCE FUNDAMENTALS, CONTINUED: SHELF ASSEMBLIES / STEPS	14-15
MAINTENANCE FUNDAMENTALS, CONT'D: DRAIN, TXV VALVE ACCESS	16
MAINTENANCE FUNDAMENTALS, CONT'D: REAR SLIDING DOORS	17
MAINTENANCE FUNDAMENTALS, CONT'D: CUTTING BOARD / REAR LEDGE REMOVAL	18
MAINTENANCE FUNDAMENTALS, CONT'D: REFRIGERATION PACKAGE LAYOUT	19
MAINTENANCE FUNDAMENTALS, CONTINUED: REMOTE UNITS WITH SLIDE-OUT FIELD ACCESS BOX	20
CLEANING SCHEDULE - TO BE PERFORMED BY STORE PERSONNEL (UNLESS NOTED OTHERWISE)	21
CLEANING SCHEDULE (STAINLESS STEEL) - TO BE PERFORMED BY STORE PERSONNEL	22
PREVENTIVE MAINTENANCE - TO BE PERFORMED BY TRAINED SERVICE PROVIDERS ONLY ...	23
TROUBLESHOOTING - TO BE PERFORMED BY STORE PERSONNEL (UNLESS NOTED OTHERWISE)	24-25
TROUBLESHOOTING - CONDENSING SYSTEM (TO BE PERFORMED BY TRAINED SERVICE PROVIDERS ONLY)	26
TROUBLESHOOTING - EVAPORATOR SYSTEM (TO BE PERFORMED BY TRAINED SERVICE PROVIDERS ONLY)	27
SERIAL LABEL INFORMATION & LOCATION	28
CAREL TEMPERATURE CONTROLLER INFORMATION	29-31
TECHNICAL SERVICE CONTACT INFORMATION & WARRANTY INFORMATION	32

THIS OPERATING MANUAL ENCOMPASSES THE FOLLOWING MODELS:
Standard G-Series Service Refrigerated Deli Case GMDS4R GMDS4R.5068 GMDS4R.5773B
GMDS5R GMDS5R.5773C GMDS6R GMDS6R.5241 GMDS6R.5773D GMDS8R
GMDS8R.5182 GMDS8R.5243A GMDS6R GMDS6R.5241 GMDS6R.5773D GMDS8R
GMDS8R.5182 GMDS8R.5243A GMDS6R GMDS6R.5241 GMDS6R.5773D GMDS8R
GMDS10R GMDS10R.5243 GMDS12R GMDS12R.5241A GMDSX4R [SCC DOC OPTION #80-01660]

OVERVIEW

- These Structural Concepts merchandisers are designed to merchandise packaged products at 41 °F (5 °C) or less product temperatures (unless custom cases with wire rack shelving).
- Product must be pre-chilled to 41 °F (5 °C) or less prior to being placed in merchandiser.
- Cases should be installed and operated according to this operating manual's instructions to ensure proper performance.
- Improper use will void warranty.

TYPE

This unit is designed for the display of products in ambient store conditions where temperatures and humidity are maintained within a specific range.

- For Type 1 Conditions (most cases): ambient conditions are to be at 55% maximum humidity and maximum temperatures of 75 °F (24 °C).
- For Type 2 Conditions: ambient conditions are to be at 60% maximum humidity and maximum temperatures of 80 °F (27 °C).
- If unsure if unit is Type 1 or 2, see tag next to serial label. See **SERIAL LABEL LOCATION &**

INFORMATION LISTED / TECH INFO & SERVICE section in this manual for sample serial labels).

COMPLIANCE

- Performance issues when in violation of applicable NEC, federal, state and local electrical and plumbing codes are not covered by warranty.
- See below compliance guideline.

WARNINGS

- This page contains important warnings to prevent injury or death.
- Please read carefully!

PRECAUTIONS and WIRING DIAGRAMS

- See next page for **PRECAUTIONS** and **WIRING DIAGRAM** information.

POWER CORD AND PLUG MAINTENANCE (FOR CASES THAT ARE NOT FIELD-WIRED)

- Caution! Risk of electric shock.
- If cord or plug becomes damaged, replace only with cord and plug of same type.
- See next page for illustration.



COMPLIANCE
This equipment **MUST** be installed in compliance with all applicable NEC, federal, state and local electrical and plumbing codes.



WARNING
Risk of electric shock. Disconnect power before servicing unit. **CAUTION!** More than one source of electrical supply is employed with units that have separate circuits. **Disconnect ALL ELECTRICAL SOURCES before servicing.**



WARNING
Hazardous moving parts. Do not operate unit with covers removed. Fan blades may be exposed when deck panel is removed. Disconnect power before removing deck panel.

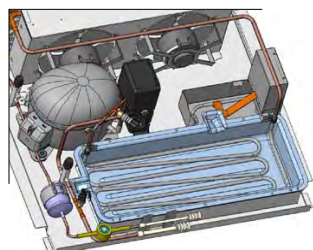

CAUTION! CHECK BOTH CONDENSATE PAN AND OVERFLOW PAN
Water on floor can cause extensive damage! Before powering up unit:
• Condensate pan **MUST BE** positioned directly under condensate drain.
• Overflow pan **MUST HAVE** single plug connected to its box. Units with optional Clean Sweep™ **MUST HAVE** two plugs connected.

PRECAUTIONS

- Following are important precautions to prevent damage to unit or merchandise.
- Please read carefully!
- See previous page for specifics on **OVERVIEW**, **TYPE**, **COMPLIANCE** and **WARNINGS**.

WIRING DIAGRAM

- Each case has its own wiring diagram folded and in its own packet.
- Wiring diagram placement may vary; it may be placed near ballast box, field wiring box, raceway cover, or other related location.



CAUTION! LAMP REPLACEMENT GUIDELINES
 Fluorescent lamps have been treated to resist breakage and must be replaced with similarly treated lamps.
 LED lamps reflect specific size, shape and overall design. Any replacements must meet factory specifications.



CAUTION! GFCI BREAKER USE REQUIREMENT
 If N.E.C. (National Electric Code) or your local code requires GFCI (Ground Fault Circuit Interrupter) protection, you **MUST** use a GFCI breaker in lieu of a GFCI receptacle.



CAUTION! CASES WITH POWER CORD AND PLUG
 Risk of electric shock. If cord or plug becomes damaged, replace only with cord and plug of same type.

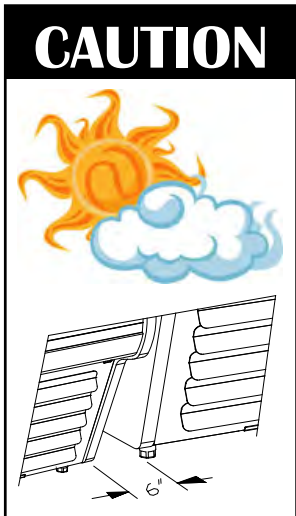

CAUTION! ADVERSE CONDITIONS / SPACING ISSUES

- Performance issues caused by adverse conditions are **NOT** covered by warranty.
- End panels must be tightly joined or kept at least 6-inches away from any structure to prevent condensation.
- Unit must be kept at least 15-feet from exterior doors, overhead HVAC vents or any air curtain disruption to maintain proper temperatures.
- Unit must not be exposed to direct sunlight or any heat source (ovens, fryers, etc.).
- Tile floors, low ceilings or small rooms will increase noise level. Whisper Cool compressor blanket or remote unit may resolve noise level issues.
- Keep at least 8-inch clearance above unit for air discharge (self-contained units only).



WARNING
 Overflow Condensate Pan Heater Rod Is Hot!
 Electric condensate pan must be disconnected and allowed to cool before cleaning or removing from case.

INSTALLATION: REMOVAL FROM SKID, REMOVING LOWER FRONT PANELS

1. Remove Case From Skid

- Remove shipping brace that may be securing case to skid.
- Support case to prevent tipping.
- **Caution! Rails can be damaged if case hits floor with heavy force!**
- Carefully slide unit to rear of skid and tip backward off skid.
- Illustration may not reflect every feature or option of your particular case.

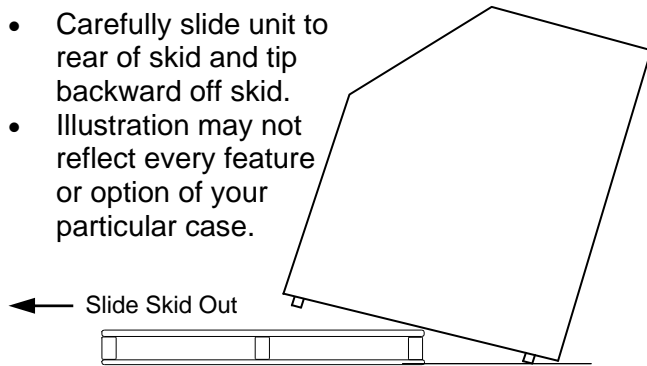

Case can be repositioned with pallet truck when front lower panel is removed. Blocking may be necessary to obtain adequate height.

2. Remove Case From Skid (Casters)

- Remove shipping brackets that may be securing casters to skid
- Place ramp up against skid (to allow case to smoothly slide off from skid).
 - Maintain support of case at all times or center of gravity may cause case to fall.
 - Unlock Casters. Roll unit to rear of skid.

Roll down ramp and off from skid.

Note: Illustrations shown reflect a general outline of sample cases and do not reflect features or options of your particular model.

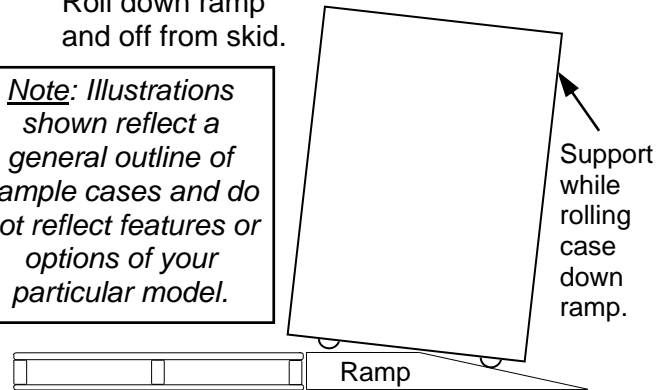

3. Removing Vertical Lower Front Panel (and Rear Panel)

Removing Lower Front Panel

- No screw removal is required to remove lower front panel.
- Simply lift lower front panel slots up and off case hooks.
- Replace in same manner it was removed.
- Rear panel is removable in same manner.
- **Note:** Illustrations below may not exactly reflect every feature or option of your particular case.

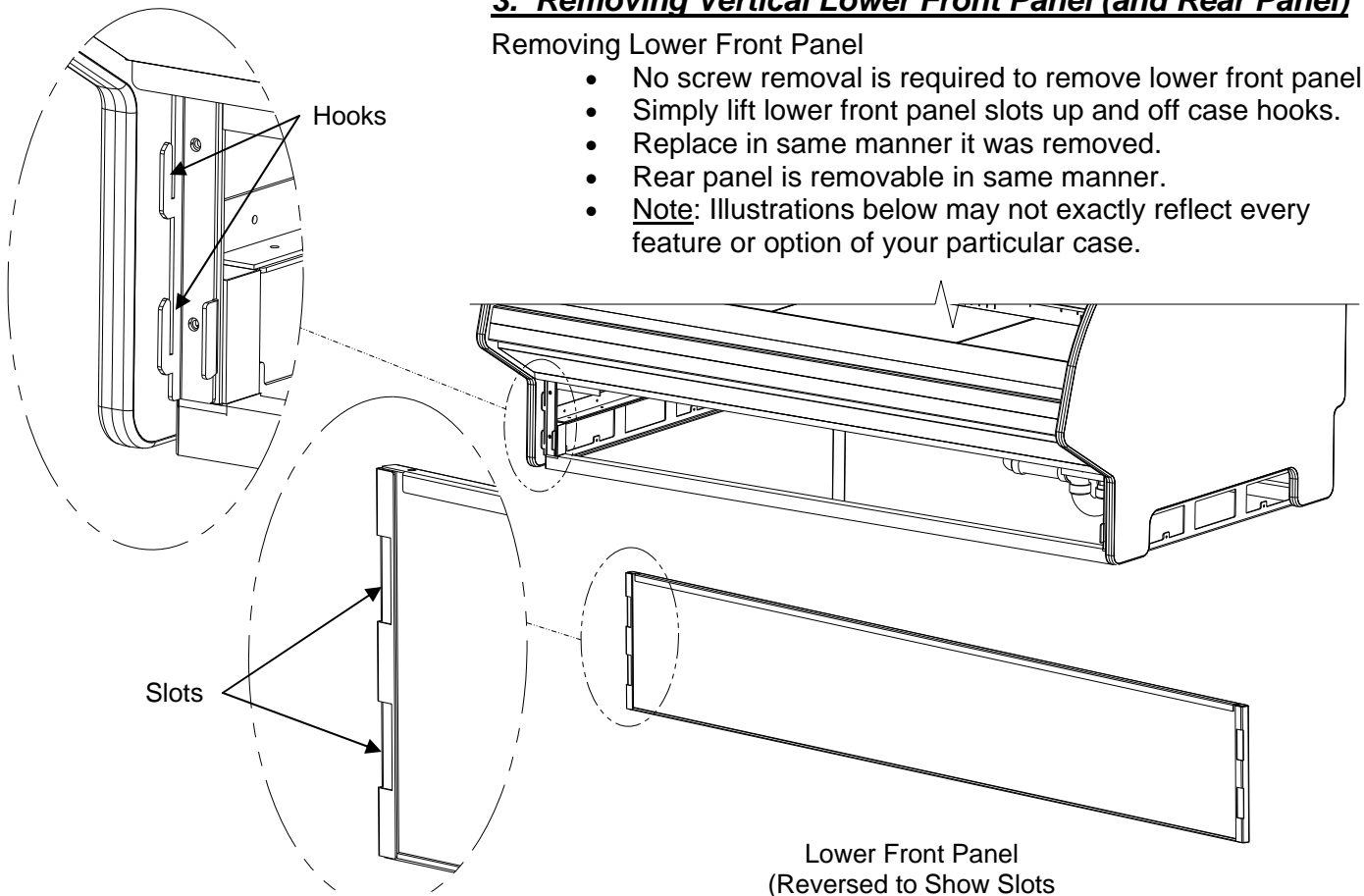

INSTALLATION, CONT'D: BOLTING and CAULKING UNITS TOGETHER

4. Bolting and Caulking Units Together

Follow these steps to assure a secure, level lineup.

- A. Begin all lineups leveling from highest point of floor.
- B. After the 'first' case is level, apply industrial grade butyl caulk on non-visible areas (at case end). Use industrial grade silicone sealant on visible areas (at case end).
- C. Form Two (2) Caulk/Sealant Lines: (Sanitation and Refrigeration). See illustration at mid-right for outline of caulk/sealant lines.
- D. Line up 'second' case bolt-hole to bolt-hole to 'first' case.
- E. Using SCC-supplied bolts (found in installation packet), insert bolts in bolt hole locations (shown at right). You may need to remove decking to access lower bolt holes.
- F. Caution! Front of cases **MUST** be flush with each other! After leveling, all cases to be same height.
- G. Using SCC-supplied nuts & bolts, lightly tighten each of the 5 to 8 bolts in a cross-wise pattern. Work your way around the pattern, tightening more firmly at each pass. Do not firmly tighten one bolt and then start on the next!
- H. After the cases are bolted together, level the 'second' case. Repeat this process for each case to be adjoined.
- I. After all lined-up cases are level, seal all seams with industrial grade silicone sealant.

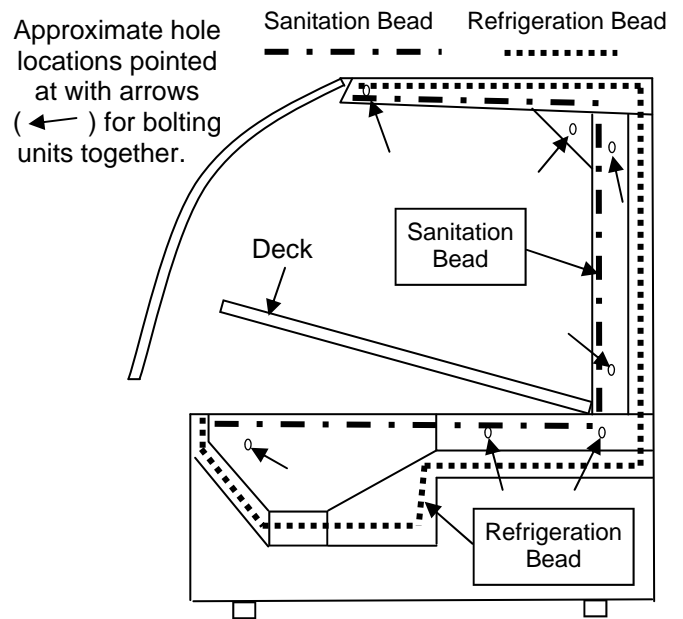

INSTALLATION, CONT'D: FRAME SUPPORT RAIL SHIMMING

Note: Unit shown may not exactly reflect every feature or option of your particular unit.

5. Position & Align Case Alongside Other Cases

- Before adjusting levelers (or shimming frame support rails), make certain that the case is in proper position and, if required, aligned with adjoining case.
- This may require the repositioning of the case you are installing or the already positioned case.
- Though case below shows both end panels, case adjoinments routinely consist of end panel removal for case-to-case placement.

6. Frame Support Rails Must Be Shimmed

- Illustration below shows case with frame support rails.
- Shims will be provided with all cases that have frame support rails.
- Use shims to level case.
- **Note: After case is in position, it must be sealed to floor to prevent entry or leakage of liquid or moisture.**

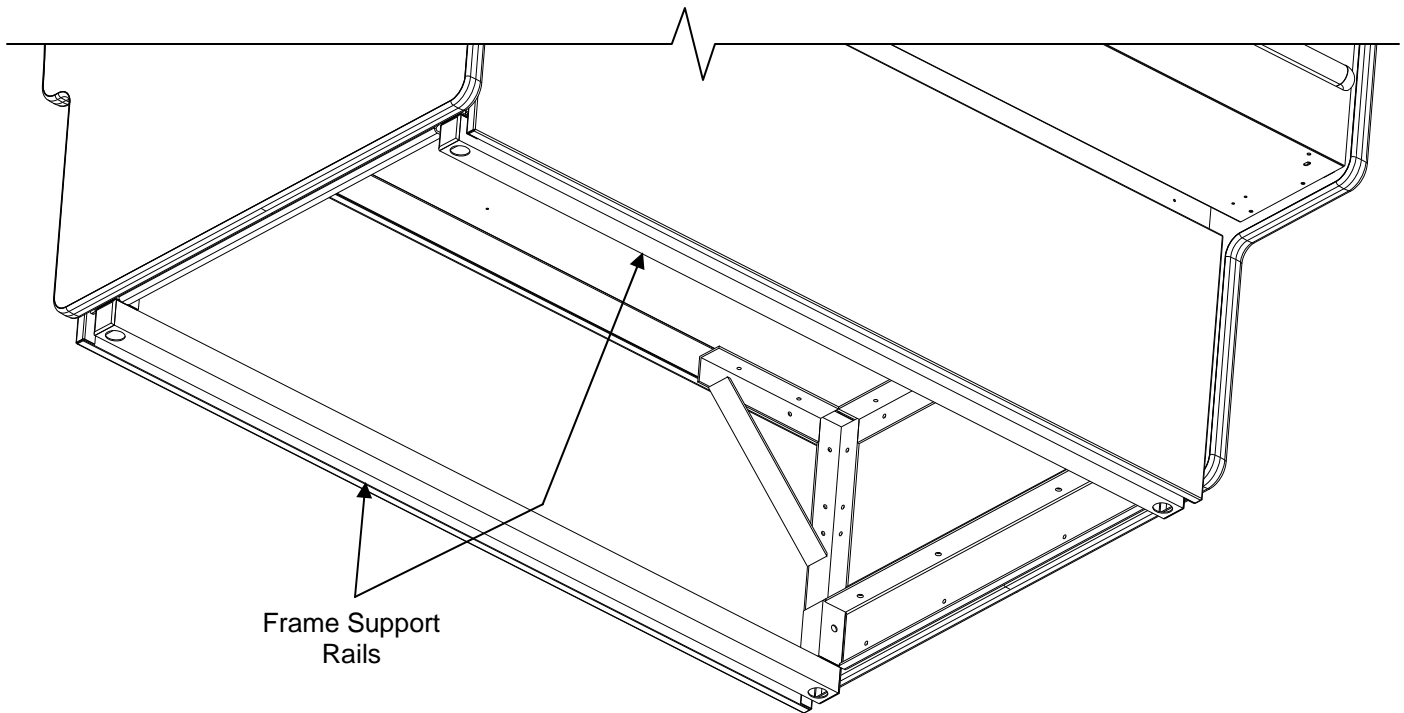

7. Front Glass Alignment & Adjustment via Rail System (For Curved and Flat Front Glass)

- Proper alignment of the front glass is important to create and maintain a seal inside the case.
- Improper alignment can cause air leaks compromising the environment inside the case and create condensation.
- Follow the five steps listed below to assure proper front glass alignment.
- Illustrations shown may not exactly reflect every feature or option of your particular case.

1. Side-to-Side Leveling: Place a level on top of display case (parallel to front glass). Raise or lower either side of case by inserting shims under the rails to level the case (following steps 3 and 4 below).

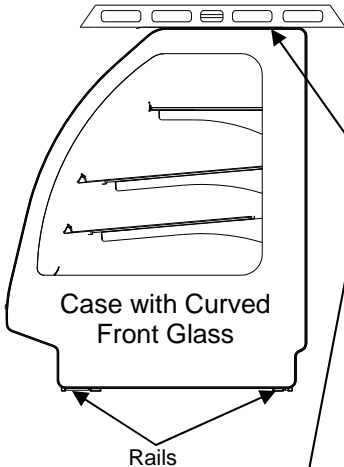

2. Front-to-Back Leveling:
- Place a level on top of case, perpendicular to the front glass.
 - Raise or lower either side of case by shimming under the rails (following steps 3 & 4 below).
 - Double-check the side-to-side level.

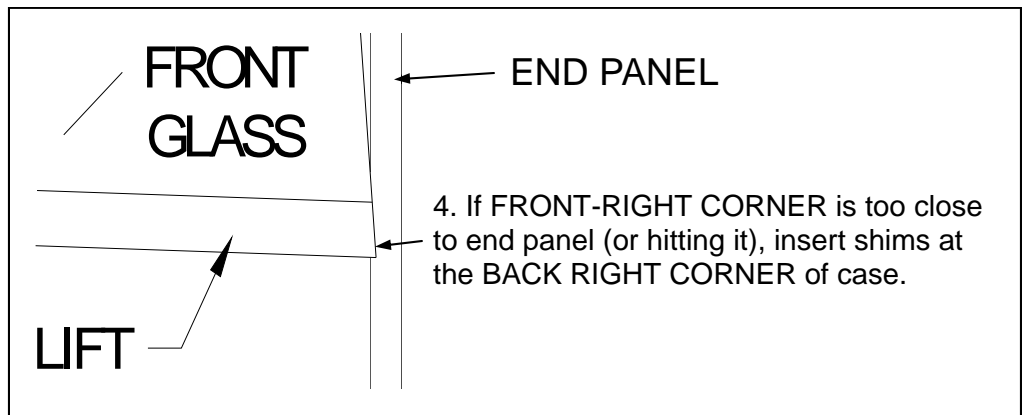
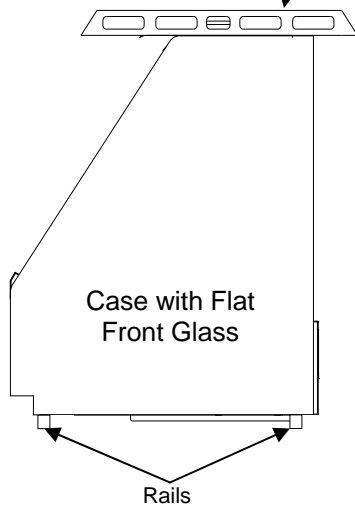
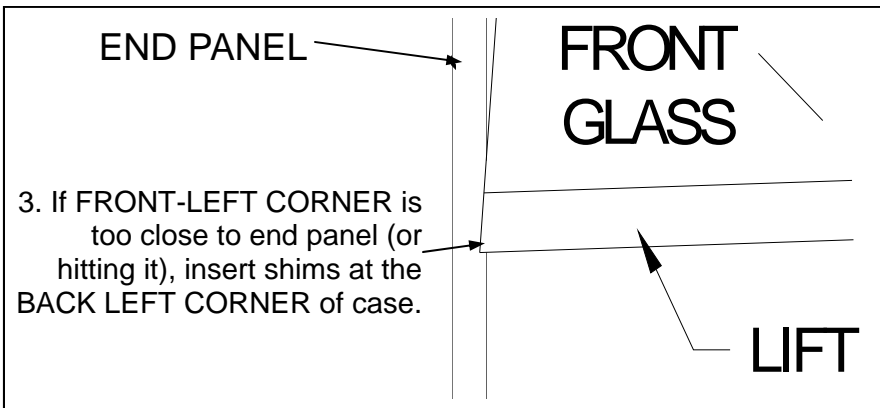
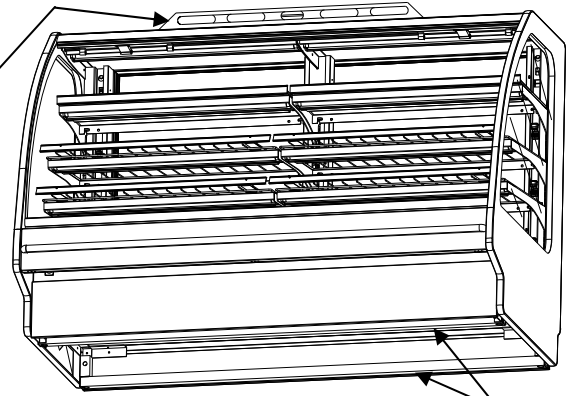

5. Verification:

- After inserting shims, open and shut the front glass.
- Verify (again) that the front glass is properly aligned at both left-hand and right-hand side of the case.
- If not, repeat the shimming procedure until the front glass is properly aligned along both sides of the case.

8. Probe Leads Box / Field Wiring Box / Ballast (or Optional LED Driver) / Terminal Strip / Anti-Condensate Axial Fans

- Probe leads are in probe leads box (on certain models). It is located at customer front-left of case (behind front panel).
- Field wiring box is also located at front left of case (behind front panel)
- Ballast (or optional LED driver) and terminal strip is also located behind front electrical cover (shown removed for illustrative purposes).
- Screws hold front electrical cover in place. Unscrew and drop electrical cover down and out.
- Anti-condensate axial fans (for front glass) may be accessed (at underside of front panel) by simply removing four screws, and dropping fans down.
- ***Caution! Only certified electricians are to access electrical components!***

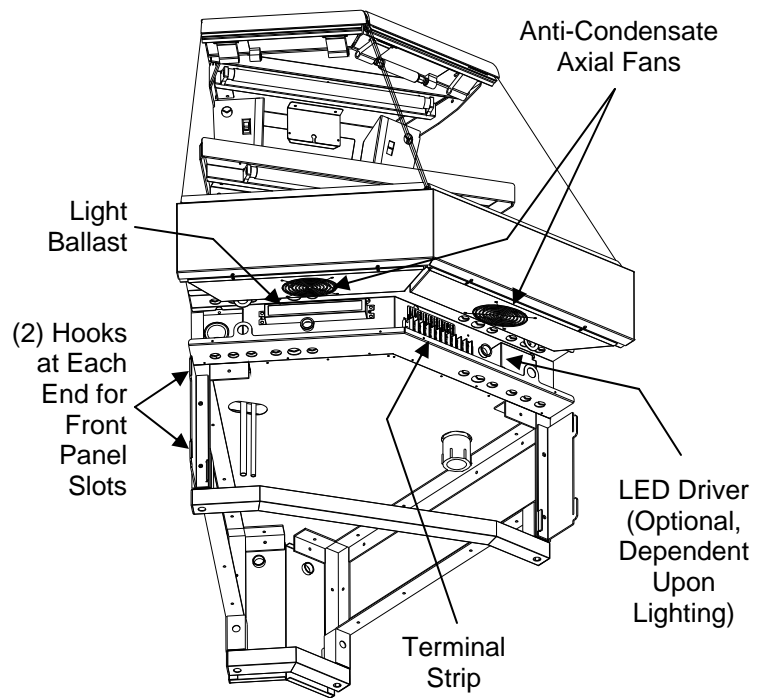

--- View of GMDSX4R With Front Panel and Electrical Cover Removed ---

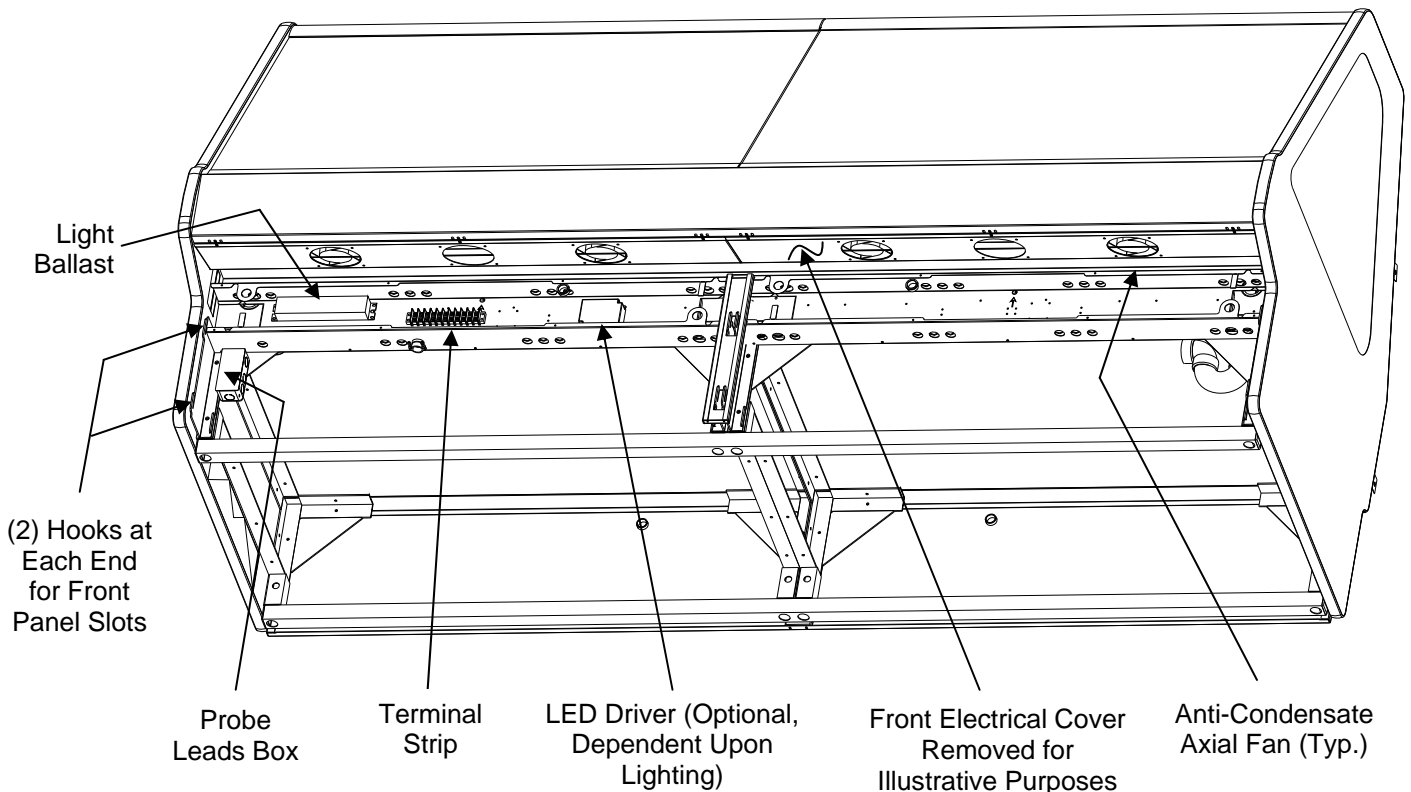

--- View of GMDS8R With Front Panel and Electrical Cover Removed ---

9. Refrigeration Line Stub-Up Connections

- Refrigerant stub-up access is at underside of case.
- Stub-up connections are accessed by removing rear panel (no screws required).
- Run case-to-case connections through cutouts in base.
- Sweat the high and low pressure connections.
- Fill access hole with suitable filler to insure watertight integrity of tub.
- Note: Illustration below may not reflect every feature or option of your particular case.

10. Drains

- Cases have drains at left and right hand sides.
- Longer cases may have drain at case center.
- Drain field connection location as shown.
- See next page for illustration of TXV Valve, Drains, Refrigeration Line Stub-Ups, etc.
- Depending upon drain access needs, either front or rear panel may be removed to gain access to drain stub-up.
- 1.5" male PVC stub-up connection is under case.
- Drain stub-up may be at case center in extended length cases.
- Connect tub drain to floor drain. Maintain 1/4"-fall per foot to provide proper drainage.

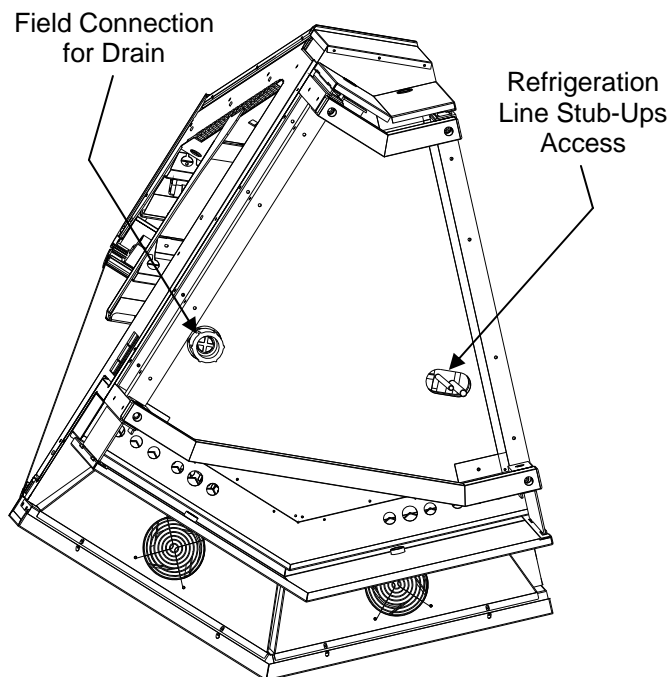

Model GMDSX4R is Shown Above. Your Case May Differ.

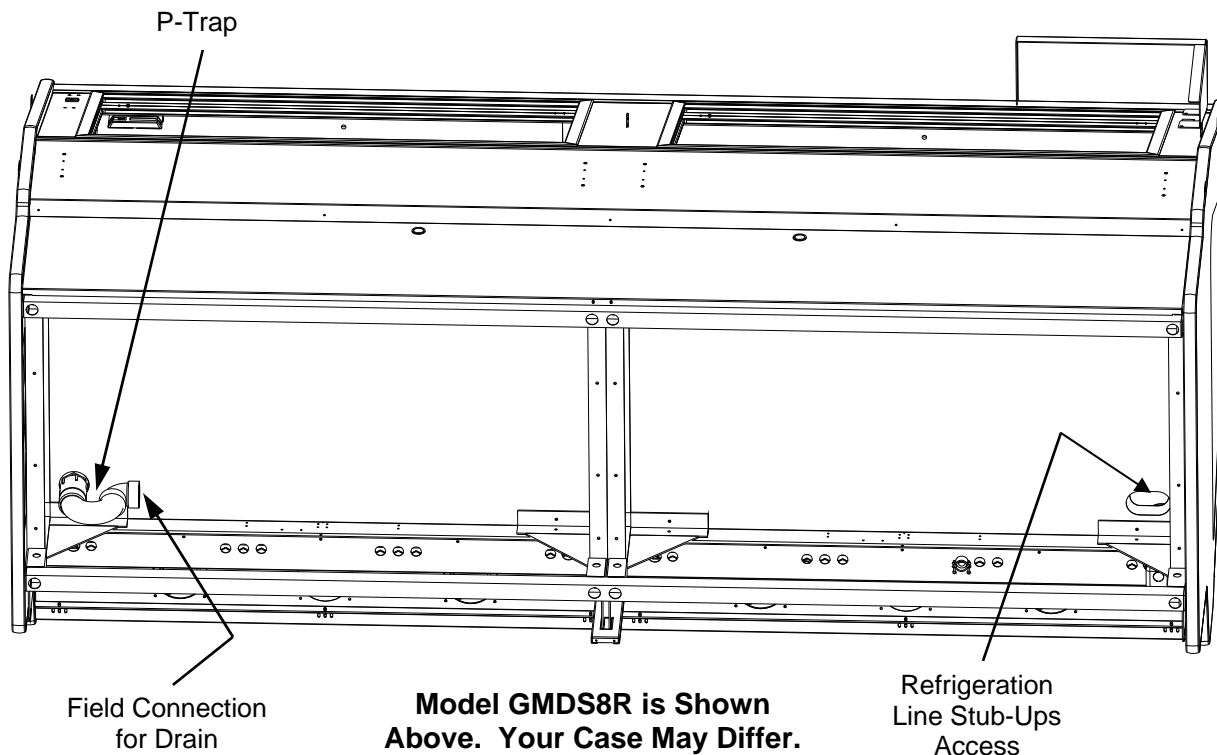

Model GMDS8R is Shown Above. Your Case May Differ.

START-UP AND OPERATION

Merchandiser Start-Up

- Unit will energize when properly field wired.
- Evaporator coil fans will automatically turn on.
From the front of the case, lift glass and remove the decking; check to see that the coil fans are all functioning properly.
- Lights switch is accessible at case front-left, near upright. See illustration below.
- Turn light switch on. All lights should come on at the same time. First time lighting may require a short warm up-period for the bulbs.
- Slightly dim or a flickering of new bulbs is normal.
 - If lights do not turn on, check all raceway plugs. The lighting is wired in series so **all lights must be plugged in or receptacles capped** in order for the case to light.
- Refrigeration section has been tested to maintain temperature at or below 5 °Celsius / 41 °Fahrenheit.
- Note: Thermometers provided with equipment reflect internal air temperature only (not actual food temperature). Use probe thermometers to determine actual product temperatures.

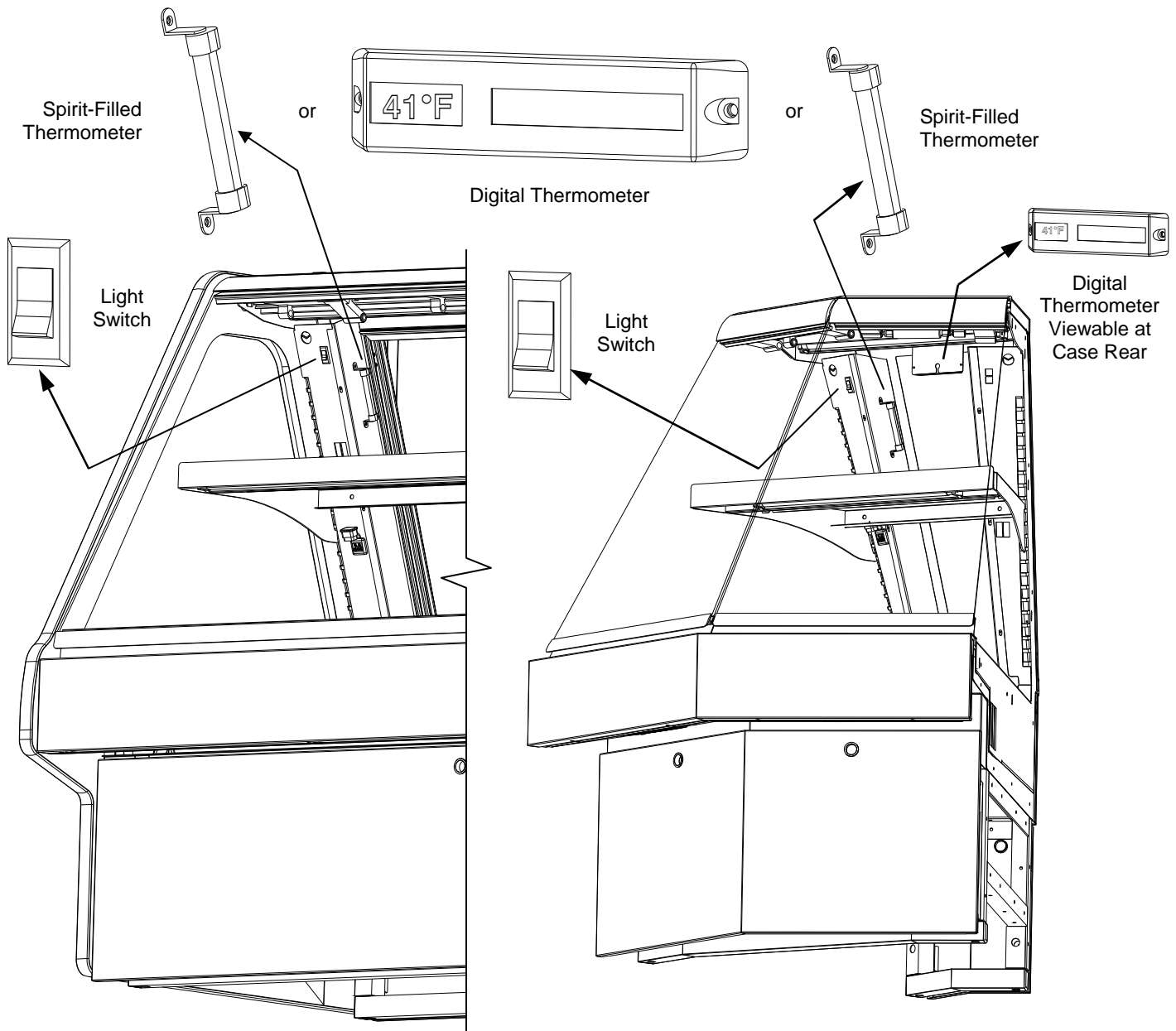

1. Standard Light Fixtures

Note: See Installation section in this manual for:

- Front Panel adjustment and removal
- Angled Base adjustment and removal
- Vertical Base adjustment and removal

Light Fixtures

Warning! Disconnect power before providing maintenance and service to unit.

Caution: Lamps have been treated to resist breakage and must be replaced with similarly treated lamps.

Note: Warranty will be void if claims arise from negligence, misuse of goods, extreme environmental conditions or improper maintenance. See Overview And Warnings section in this operating manual.

Light fixtures are located on underside of shelf assemblies and at the top inside of case. See illustration at top-right for locations.

Removal of lamp:

- Rotate lamp (1/4-turn) either direction to disengage (upper or lower) pins/contacts from lamp-mounting sockets.
- Remove bulb by applying even pressure from back side at the bulb ends and pulling remaining contact from sockets.
- See illustrations at mid and lower-right.

Installation of lamp:

- Align pins with slot.
- Insert pins into socket by rotating the bulb 1/4-turn to secure either the (upper or lower) pin contacts into the sockets.
- Rotate remaining bulb contacts (1/4-turn) into remaining lamp mounting socket contacts.
- See illustrations and photos at right.

Model GMD8R
Light Fixtures

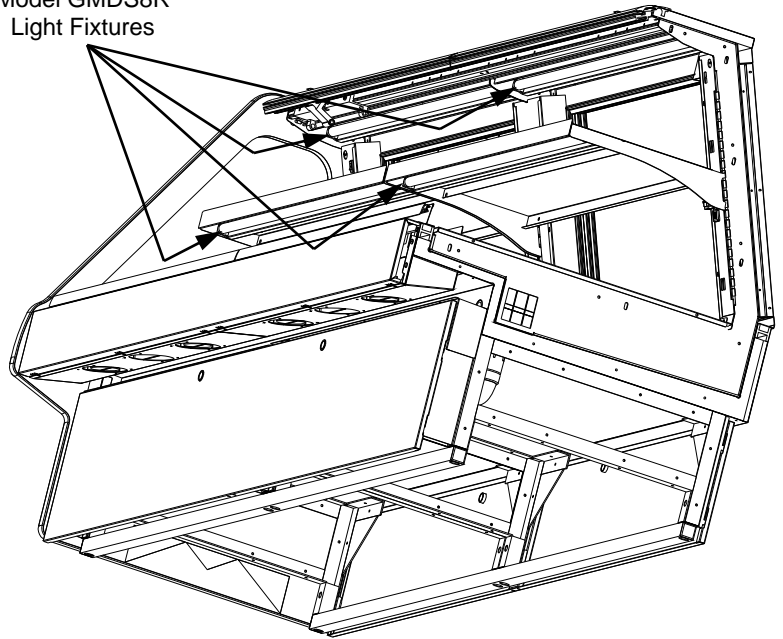

Model GMD8X4R
Light Fixtures

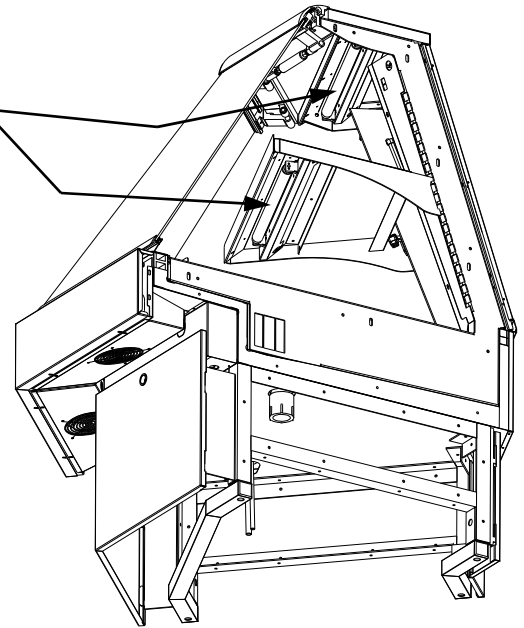

2. Shelf Assembly (Standard Style)

- Shelves may be removed from uprights for cleaning or service.
- For lighted shelving, unplug the light cord and detach from the rear shelf support prior to removing from case.
- Remove brackets. **Note: It may be necessary to remove the bracket retainer.** Pliers will be required to accomplish this task; pull bracket retainers out of upright toward front of case.

- **Note:** Depending upon model and options chosen, shelf assembly may be tilted forward at 5° increments (see illustration below right).
- See next page for additional shelf assembly styles (and step styles) on various models.

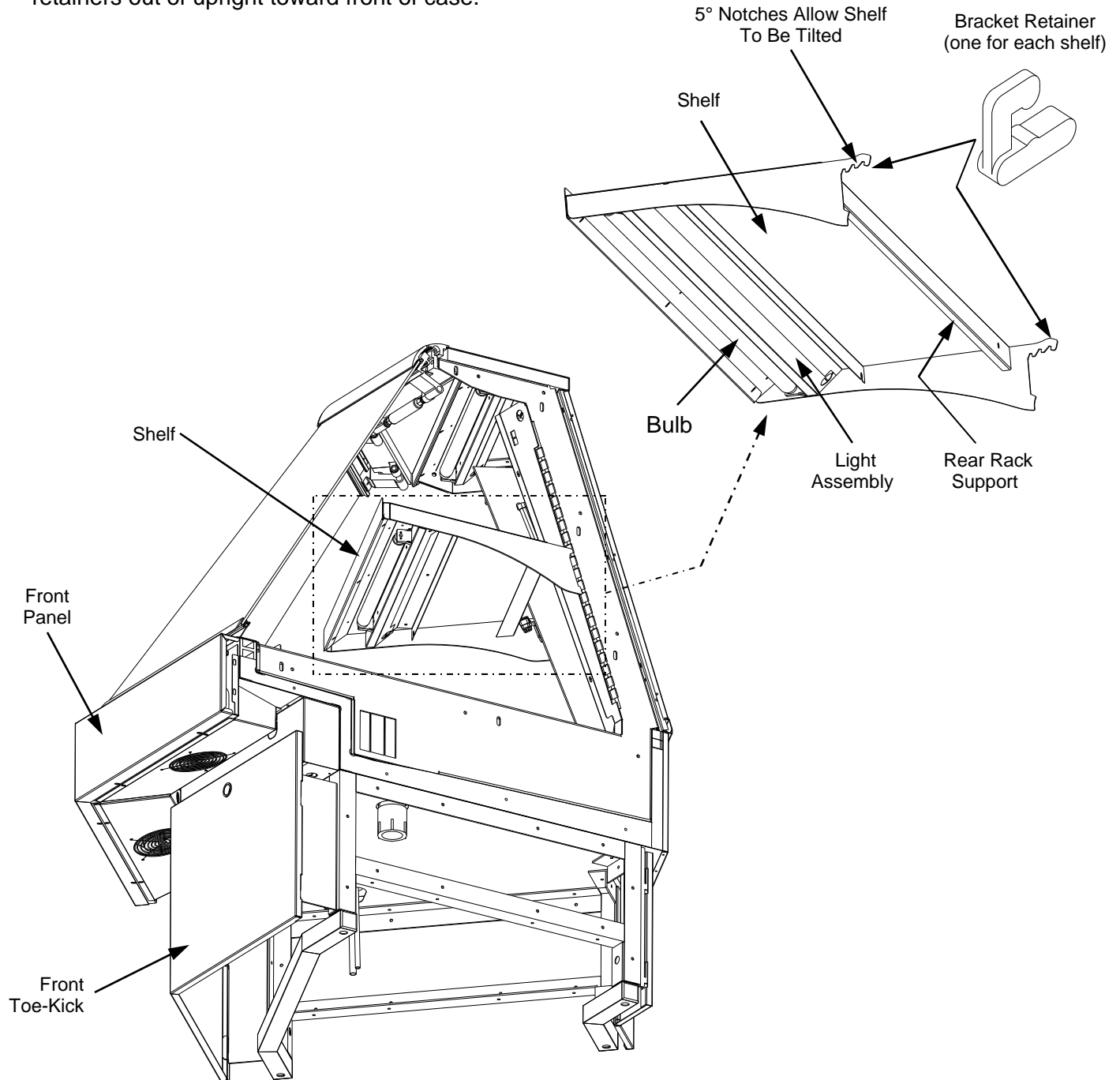

3. Shelf Assembly (Optional Styles)

- Shelves may be removed from uprights for cleaning or service.
- For lighted shelving, unplug the light cord and detach from the rear shelf support prior to removing from case.

4. Steps

- Steps can vary in size and style.
- Models GMDSES6R / GMDSES8R / GMDSES12R offer optional steps as shown below. Your unit's style may vary.
- See next page for additional shelf assembly and step styles.

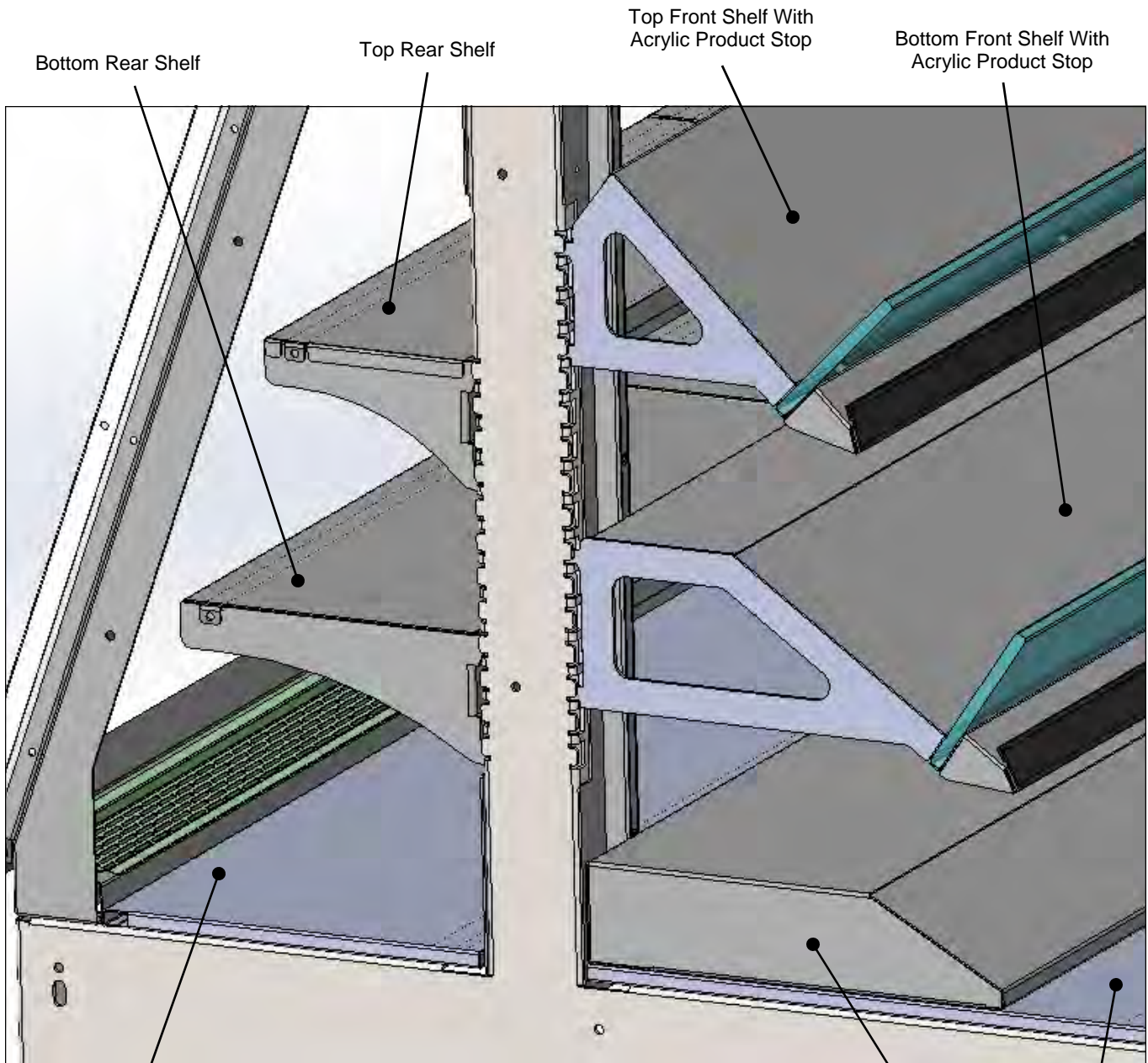

Models GMDSES6R / GMDSES8R / GMDSES12R Offer Above Options

5. Shelf Assembly (Optional Styles)

- Shelves may be removed from uprights for cleaning or service.
- For lighted shelving, unplug the light cord and detach from the rear shelf support prior to removing from case.
- Models GMDSES6R / GMDSES8R / GMDSES12R offer shelf assembly designs shown below. Your unit's style may vary.

6. Steps

- Steps vary in size and style.
- Models GMDSES6R / GMDSES8R / GMDSES12R offer optional steps as shown below. Your unit's style may vary.
- See previous page for additional shelf assembly and step styles.

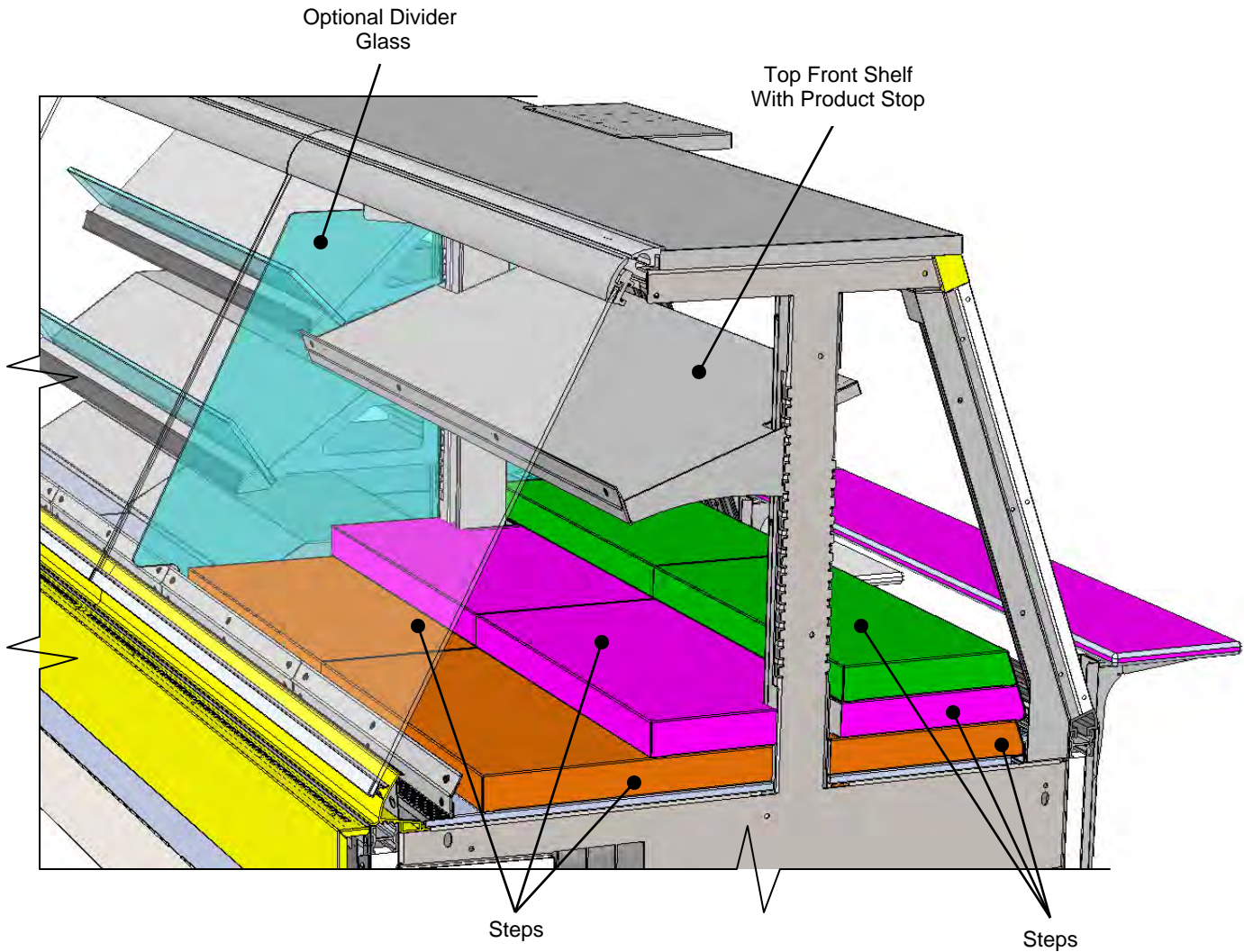

Models GMDSES6R / GMDSES8R / GMDSES12R
Offer Above Options

7. Drain and Expansion Valve Access

- The drain and expansion valve are both accessible from the front of the case.
- Unplug the fans (one plug per side) and remove the fastener from the access panel in the front right (or left) corner of the unit.
- The drain and the expansion valve (TXV) is directly below the access panel.

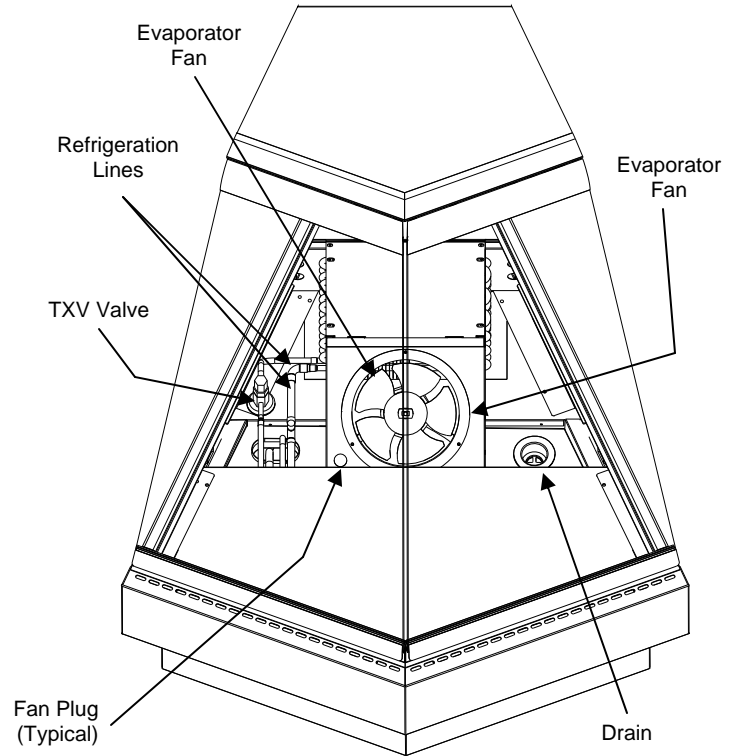

**Model GMDSX4R is Shown Above
With Pan & Shelf Removed**

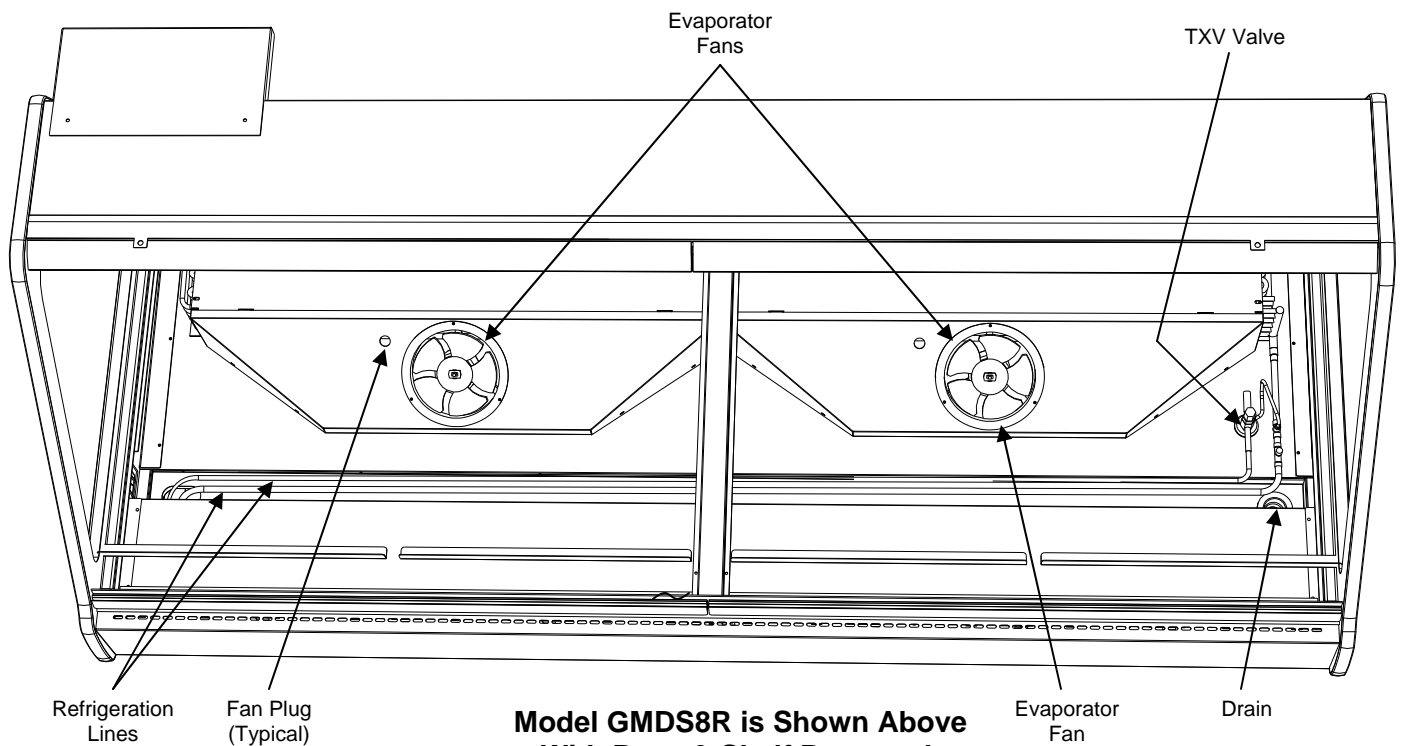

**Model GMDS8R is Shown Above
With Pans & Shelf Removed.
Your Case May Differ**

8. Removing the Rear Sliding Doors

Note: Doors are not interchangeable. There is an inner and outer door. The outer must be removed first and replaced last.

- The outer door is the right hand door (from the service side or rear of case).
- It is identified by a stop located at the lower right hand corner to the inside of the case.
- Move doors toward the center of the case.
- Individually lift each door up toward the top of the case; pivot the bottom of the door out.
- Carefully set rear sliding doors down to prevent them from falling.
- Replace rear sliding doors in reverse order they were removed.

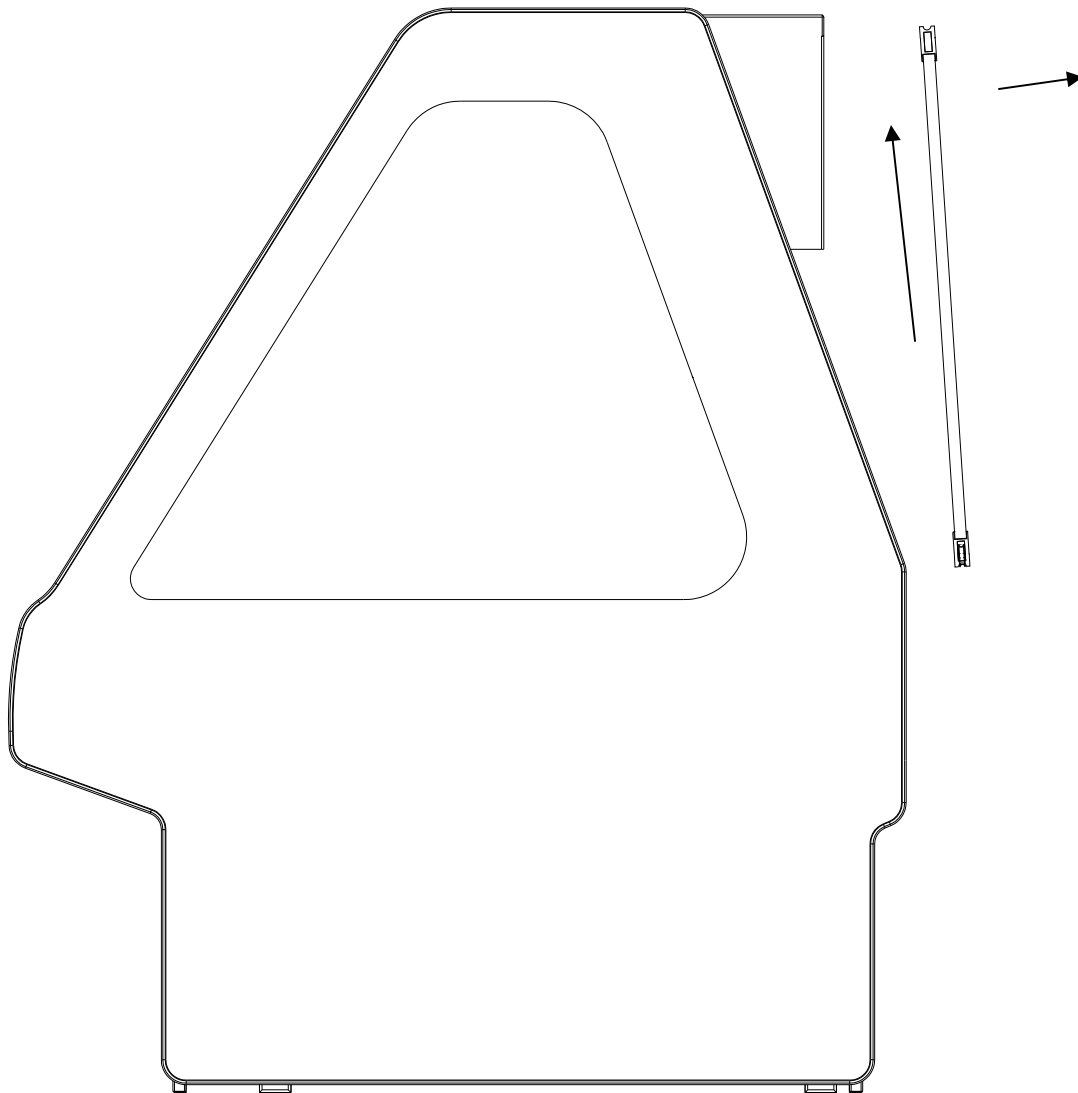

Case With Single Set of Rear Sliding Doors

9. Cutting Board / Rear Ledge Removal Steps

The illustrations at right and below reflect step-by-step removal method.

1. Hinged Support Bracket is shown in its standard upright position.
- 2 & 3. While upright, Rear Ledge must be slid away from case and then rotated downward to vertical position.
- 3 & 4. From the shelf's lowered position, lift from bottom edge upward to disengage shelf track (and attached Rear Ledge) from bracket.

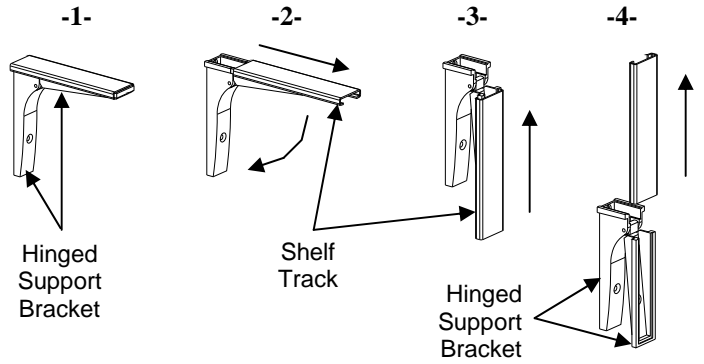

————— Rear Ledge Removal Steps —————
 Note: For clarity, only Shelf Track is shown being removed. Rear Ledge is attached to Shelf Track.

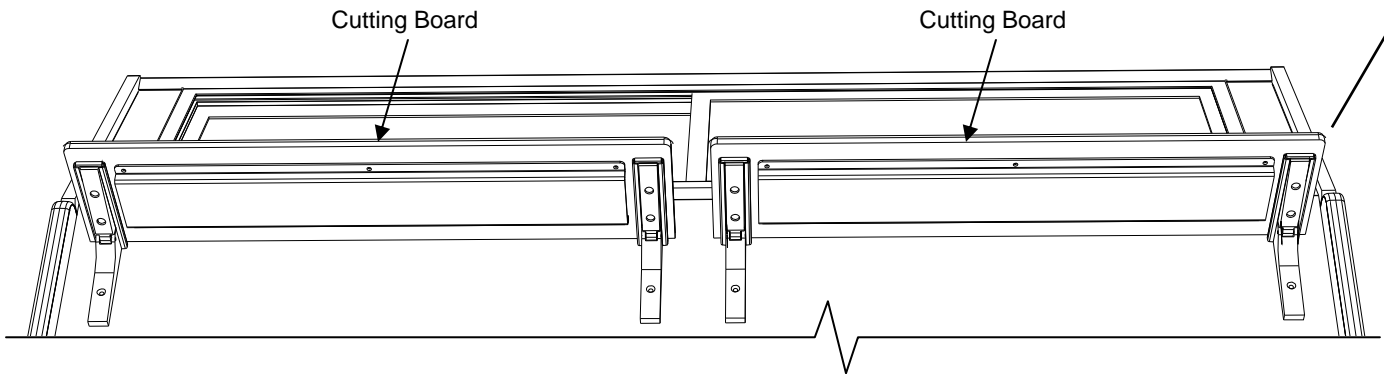

10. General EnergyWise Refrigeration Package Configuration

- Note: Your particular compressor may have slightly different refrigeration package layout.

1	Fan Shroud / Condenser Coil Cover: (Optional: May Have Shroud Attached to House Clean Sweep™ Automatic Condenser Coil Cleaner)	7	Hot Gas Condensate Evaporator Pan
2	Fan Motor & Bracket	8	Hot Gas Loop
3	Condenser Coil Tubing	9	Sight Glass
4	Receiver	10	Filter / Drier
5	Electrical Box (To Overflow Condensate Pan)	11	Hot Gas Loop Compressor
6	Overflow, Hot Gas Condensate Evaporator Pan	12	Start Components, Hot Gas Loop Compressor

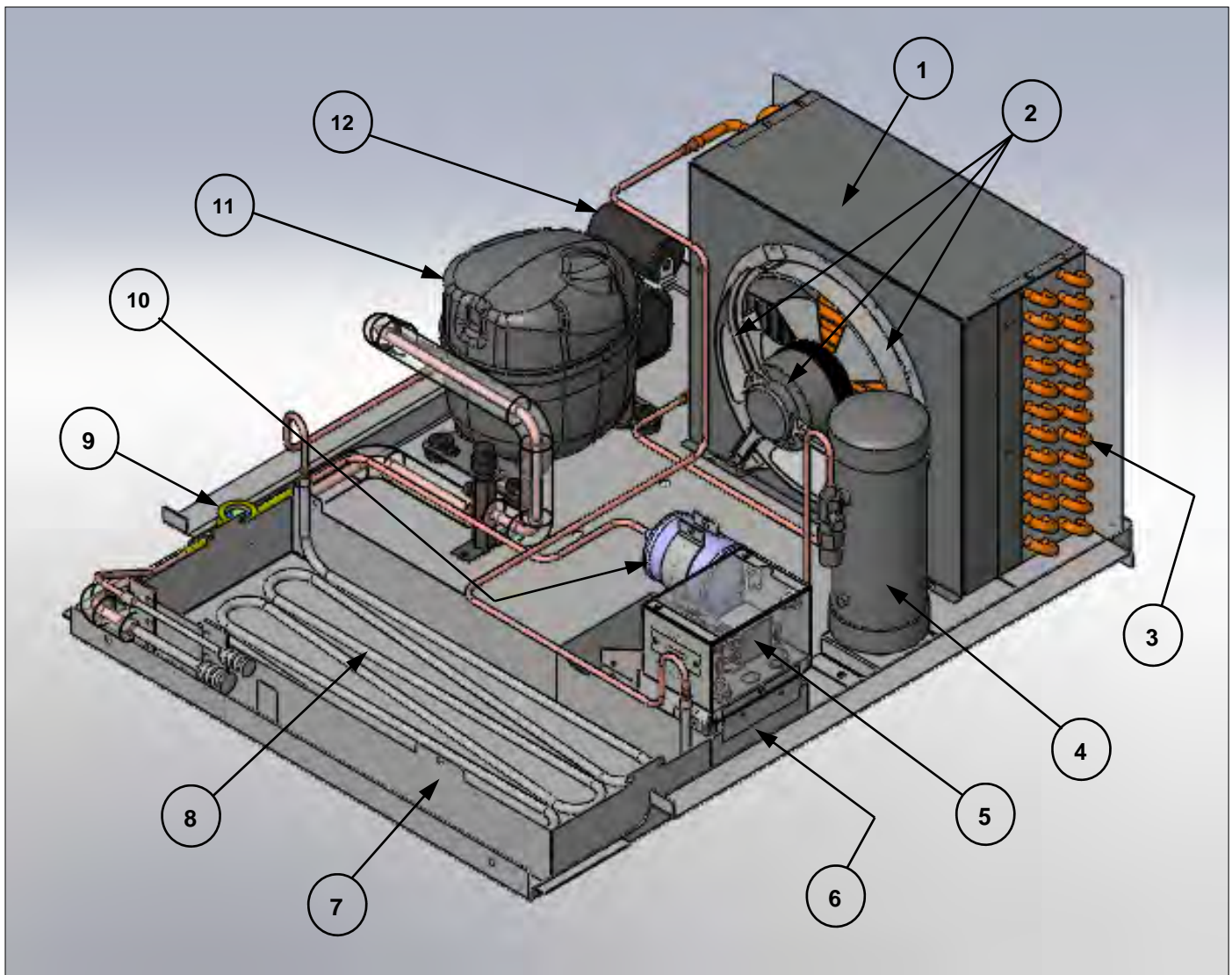

11. Electrical Connections

Field Access Boxes, Electrical Outlets, LED Drivers, Circuit Board, Transformer, Terminal Strips, Dixell® Temperature Controller, Etc.

> Note: Rear panel is shown transparent.

- Access to field access box is at case rear with rear panel removed (no screw removal required).
- Note: Wiring process must be performed by certified electrician only.
- When case is properly field-wired, it will energize (no main power switch required).

12. Dixell® Thermostat Controller

- Dixell® thermostat controller is in the pull-out electrical box (accessible at case rear).
- Dixell® display is also at case rear (as shown at upper-right below).
- See your Dixell® operating instructions for more information.

13. Model Illustration Compatibility

- Model shown below is GMDSE6R.
- Models GMDSE8R & GMDES12R have similar remote layouts.
- Your model may slightly differ.

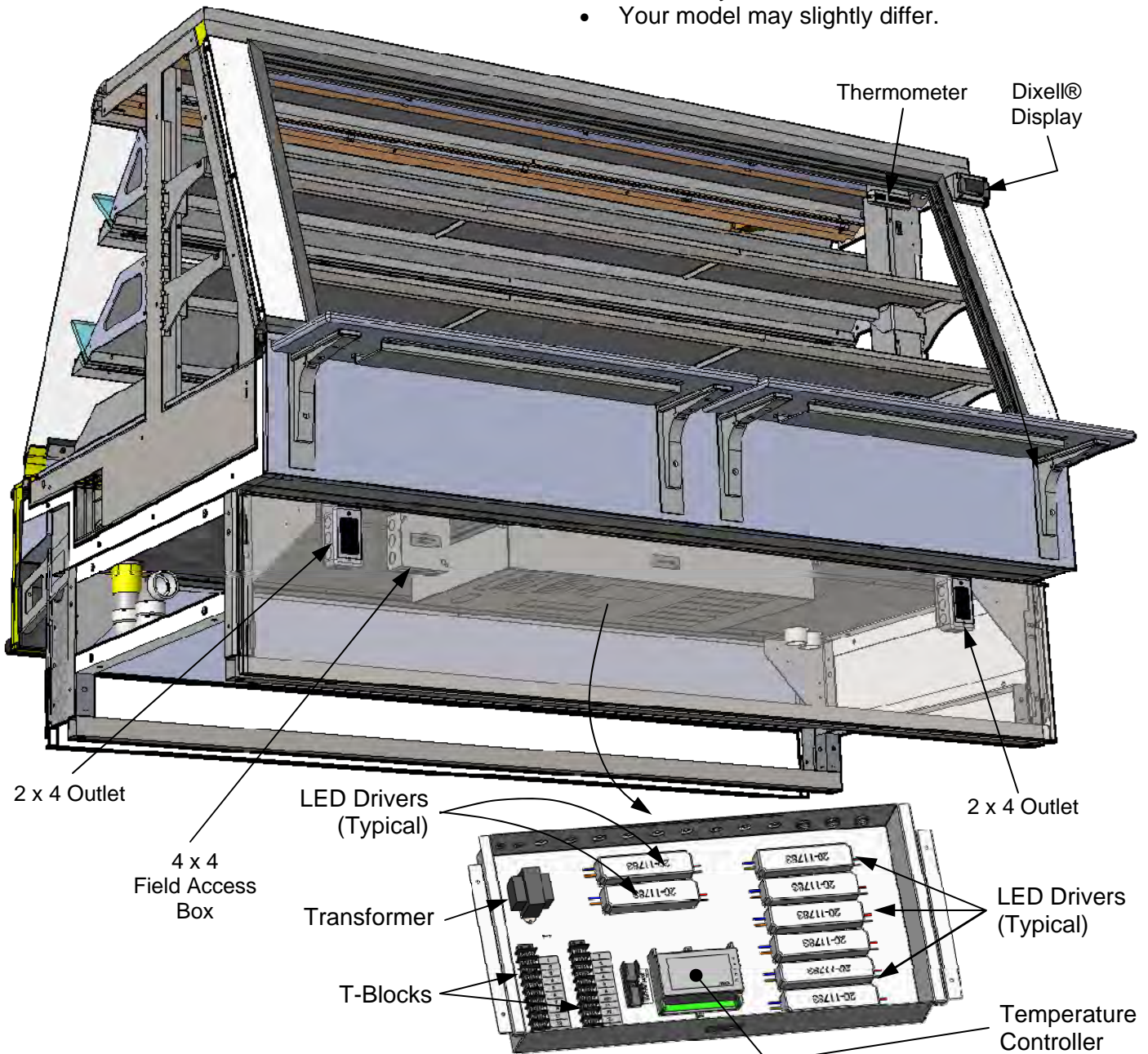

CLEANING SCHEDULE - TO BE PERFORMED BY STORE PERSONNEL (UNLESS NOTED OTHERWISE)

AREA	FREQ.	INSTRUCTIONS
Exterior	Daily	All Glass / Mirrors: Clean side glass, front glass and mirrors with household or commercial glass cleaner. Clean out door track with moist cloth.
	Daily	Rear Sliding Door Exterior Glass: Clean with household or commercial glass cleaner.
	Daily	End Panels, Front Panel, Toe-Kick, etc.: Wipe off all surfaces with warm water and mild soap solution and non-abrasive cloth.
	Weekly	Wood, Laminate and Painted Surfaces: Clean with mild soap and water solution and a soft cloth .
	Weekly	Air Filter (with Magnetic Strips) on Rear Grille (Self-Contained Units Only): Remove air filter. Rinse with hot water against air flow direction. Use mild detergent to remove smoke and grease stains.
	Monthly	Under Case Cleaning: Remove front toe-kick (or rear panel). Vacuum under case to remove all dust and dirt. Replace front toe-kick (or rear grille) when complete.
Interior	Weekly	Decks: Wipe off decks with moist cloth dipped in mild soap and water solution.
	Monthly	<p>Tub and Drain (Trained Service Providers Only): Caution! Turn off power to unit before proceeding. Area at underside of decking must be kept free of debris which could clog tub and drain. To access drain area, remove the deck and fan shroud.</p> <ul style="list-style-type: none"> • Use spray bottle and brush to dislodge residue. Use wet-vac on tub, trough and drain to remove residue. • Caution! Avoid splattering water over the case and surrounding areas!
	Monthly	<p>Condensing Coil:</p> <ul style="list-style-type: none"> • Remove grille (by lifting up and off). • Use air pressure or industrial strength vacuum; clean dust and dirt that may collect on the condenser coil. • Caution! Coil fins are sharp. Handle with care! • Replace rear grille to case.

CLEANING SCHEDULE (STAINLESS STEEL) - TO BE PERFORMED BY STORE PERSONNEL

General Stainless Steel Surface Cleaning (To Be Performed As Often As Needed):

- Certain grades of stainless steel, and some are more prone to corrosion than others.
- Stainless steel can become exposed to a wide variety of contaminants, which if left untreated can cause stains and rust.
- Stainless steel requires a specific cleaning procedure to maintain its sheen and remain rust-free.
- Wash with a solution of liquid dishwashing detergent and hot water.
- Rinse with pure hot water from spray bottle. Wipe with clean sponge. This will remove soap residue that can lodge in stainless steel's microscopic grooves, causing rust.
- Dry with clean, soft cloth or paper towel.
- ***Caution!*** To prevent rust, you ***MUST*** rinse with pure hot water from a spray bottle while wiping with clean sponge after EACH cleaning.
- ***Caution!*** Never clean with scouring powder or steel wool as they can mar, scratch and/or erode the surface of stainless steel. When the surface properties of stainless steel have been compromised, rust can form.

Brightening:

- **Method 1:** Brighten by polishing with a soft cloth or sponge with a solution of one part vinegar to 2 parts water in a spray bottle.
- **Method 2:** Sprinkle baking soda on sponge and rub gently with soft cloth or sponge.
- ***Caution!*** To prevent rust, you ***MUST*** rinse with pure hot water from a spray bottle while wiping with clean sponge after EACH cleaning.
- Dry with clean, soft cloth or paper towel.

Removing Streaks or Stains:

- **Method 1:** Place two teaspoons of rubbing alcohol on a microfiber cloth or pad. Rub the cloth along the grain of the appliance until the entire area has been wiped. The rubbing alcohol will air dry itself.
- **Method 2:** Dip soft cloth or sponge in club soda and rub gently over area of concern.
- ***Caution!*** To prevent rust, you ***MUST*** rinse with pure hot water from a spray bottle while wiping with clean sponge after EACH cleaning.
- Dry with clean, soft cloth or paper towel.

Polishing:

- Place a dab of olive oil onto clean soft cloth. Spread over area until a light sheen is observed. Use pressure to "work the oil" into the small grooves in the surface. Apply firm, steady pressure using small circular motions.
 - > **Dry buff:** Remove excess oil with clean cloth or paper towel using small circular motions.
 - > **Wet buff:** Use an ounce or white vinegar with clean cloth or paper towel using small circular motions.
 - > Continue wiping until oily finish has been removed.
- ***Caution!*** To prevent rust, you ***MUST*** rinse with pure hot water from a spray bottle while wiping with clean sponge after EACH cleaning.
- Dry with clean, soft cloth or paper towel.

Removing Rust:

- If rust has begun to form, there are a variety of products that can treat it.
- Among these are CLR® (calcium, lime and rust remover) and Chemetall Oakite 33 (rust, oxides and scale remover).
- ***Caution!*** To prevent food contamination, personal injury or further corrosion, carefully follow the recommended cleaning precautions and instructions.

PREVENTIVE MAINTENANCE - TO BE PERFORMED BY TRAINED SERVICE PROVIDERS ONLY

WARNING! TURN OFF CASE BEFORE PERFORMING PREVENTIVE MAINTENANCE!

PREVENTIVE MAINTENANCE	FREQ.	INSTRUCTIONS
Case Exterior	Quarterly	<p><u>Condensing Coil:</u></p> <ul style="list-style-type: none"> • Remove grille (by lifting up and off). • Use air pressure or industrial strength vacuum; clean dust and dirt that may collect on the condenser coil. • Caution! Coil fins are sharp. Handle with care! • Replace rear grille to case.
	Quarterly	<p><u>Refrigeration Package/Compressor Area (Self-Contained Units Only):</u> <i>Caution! Be certain to disconnect power from case before cleaning refrigeration package!</i></p> <ul style="list-style-type: none"> • <i>Warning! Overflow condensate pan is HOT! Disconnect power from case and allow to cool before cleaning evaporator pan!</i> • Slide/roll compressor package out from under case. • Use a scrub-brush and a de-scaling solution such as CLR® (to prevent corrosion, lime and rust). Follow instructions as to proper dilution, safety precautions and scrubbing method. • After thoroughly cleaning pan with scrub-brush and solution, rinse thoroughly with clean water (in spray bottle) and wipe dry with sponge or paper towel. • Use moist cloth to wipe off dust & debris that collects on various parts (fans, sight glass, overflow pan, etc.). • Slide refrigeration assembly back under case. • Replace front panel and lower grille via hooks (no screws required).
	Quarterly	<p><u>Under Case Cleaning:</u> Once refrigeration package is clear of unit, vacuum under case to remove all dust and dirt that collects under case.</p>
Case Interior	Quarterly	<p><u>Tub, Coil, Drain, Evaporator Fans, Brackets:</u></p> <ul style="list-style-type: none"> • Remove decking. • Use vacuum to clean entire area. • After vacuuming, clean area with warm water, clean cloth, and mild soap solution. • Remove any debris that may clog drain.
	Quarterly	<p><u>Honeycomb:</u> Check honeycomb air diffuser to determine whether it is dirty. If dirty, remove from case. Clean with mild detergent. Rinse with high-pressure sprayer. Dry. Return to case.</p>

TROUBLESHOOTING - TO BE PERFORMED BY STORE PERSONNEL (UNLESS NOTED OTHERWISE)

CONDITION	TROUBLESHOOTING
Product is Drying Out	<u>Trained Service Providers Only</u> : Check the relative humidity in the store.
Water Is On The Floor	<u>Trained Service Providers Only</u> : Check that the drain trap is free of debris.
	Check that the drain hose is correctly positioned over hot gas condensate pan.
	<u>Trained Service Providers Only</u> : Check store conditions. <ul style="list-style-type: none"> • For NSF® Type 1 Conditions (most cases): ambient conditions are to be at 55% max. humidity / 75 °F. • For NSF® Type 2 Conditions: ambient conditions are to be at 60% maximum humidity / 80 °F.
Fan Emits Excessive Noise	<u>Trained Service Providers Only</u> : Check that the case is aligned, level and plumb.
	<u>Trained Service Providers Only</u> : Check evaporator fan for cleanliness.
	<u>Trained Service Providers Only</u> : Unplug/power off fan motors. Check motor shaft for bearing wear.
	<u>Trained Service Providers Only</u> : Check that fan motors are securely mounted in brackets.
	<u>Trained Service Providers Only</u> : Verify that fan blades are securely mounted to fan motor.
	<u>Trained Service Providers Only</u> : Check that nothing is preventing blade rotation.
	<u>Trained Service Providers Only</u> : Check that the fan shroud is properly secured.
Fans Are Not Working	Check that the MAIN power switch is on.
	<u>Trained Service Providers Only</u> : Check that fans are plugged in at the fan shroud.
	<u>Trained Service Providers Only</u> : Check for foreign material obstructing fan performance.
	<u>Trained Service Providers Only</u> : Check that fan blades freely rotate within fan shrouds.
	<u>Trained Service Providers Only</u> : Check that power is going to fans.
	<u>Trained Service Providers Only</u> : Check that fan wiring is connected on terminal blocks
Digital Control Display Is Blank	Check that the MAIN power switch is on.
	<u>Trained Service Providers Only</u> : Check the circuit breaker box for tripped circuits.
System Not Operating	<u>Trained Service Providers Only</u> : Check that the utility power is on.
	Check that the MAIN power switch is on.
	<u>Trained Service Providers Only</u> : Check the circuit breaker box for tripped circuits.

TROUBLESHOOTING - TO BE PERFORMED BY STORE PERSONNEL (UNLESS NOTED OTHERWISE)

CONDITION	TROUBLESHOOTING
Case Lights Not Working	Check that light switch has been flipped on.
	Check bulbs for proper installation and connection.
	Check for burned out bulbs.
	Clean dirt and dust from the bulbs to prevent flickering.
Not Holding Temperature	If a large amount of warm product was added to the case, it will take time for the temperature to adjust. Unit needs product to be pre-chilled.
	Temperature changes during defrost mode but will return to normal. Fourth LED will indicate defrost cycle in progress.
	Check that case is not in sun or near a heat or air-conditioning vent.
	If case is located near outside doors, temperature fluctuation can hinder unit's ability to maintain temperature.
	Check that condenser coil has been cleaned.
	Check air return grilles for obstructions.
	<u>Trained Service Providers Only:</u> Check sight glass for flashing and/or low charge.
	<u>Trained Service Providers Only:</u> Check set point temperature; it may be adjusted too high.
Condensing Unit Is Not Operating	Check that the power is turned on.
	Determine if temperature controller settings are properly set. <i>See your case's serial label for your model's specified settings. See SERIAL LABEL LOCATION & INFORMATION LISTED / TECH INFO & SERVICE section in manual for label location, etc.</i>

TROUBLESHOOTING - CONDENSING SYSTEM (BY TRAINED SERVICE PROVIDERS ONLY)

CONDITION	TROUBLESHOOTING
Head Pressure Too High	Check that the Condensing Coil is not dirty or covered.
	Check that Condensing Fans are working.
	Check that refrigerant is not overcharged.
	Check to verify that a non-condensable is not in the system.
	Check that Liquid Line Drier is not plugged.
	Check that there are no close-offs around Condensing Coil.
	Check Set Point Temperature; it may be adjusted too high.
	Check System Operating Temperatures.
	Check that Store Ambient Temperature isn't above maximum allowed. See OVERVIEW / TYPE / COMPLIANCE / WARNINGS / PRECAUTIONS / WIRING / PLUGS section in this manual.
Head Pressure Too Low	Check that Refrigerant Charge isn't too low.
	Check that Suction Pressure isn't too low.
	Check to verify that Compressor Valves aren't bad.

TROUBLESHOOTING - EVAPORATOR SYSTEM (BY TRAINED SERVICE PROVIDERS ONLY)

CONDITION	TROUBLESHOOTING
Low Suction Pressure	Check that the Refrigerant doesn't have a low charge.
	Check that Expansion Valve (TXV Valve) isn't restricted.
	Check that Liquid Line or Filter isn't restricted.
	Check that Evaporator Motors are working.
	Check that High Superheat doesn't need adjusting.
	Check that the Thermostatic Element charge isn't depleted.
	Check that there is no air seepage around Condensing Coil.
	Check that the Coil is not iced up.
High Suction Pressure	Check that Refrigerant Charge isn't too high.
	Check that Compressor Valves aren't bad.
	Check that the Cooling Load isn't high.
	Check that Superheat Adjustment isn't low.
	Check TXV Bulb Installation a. Poor thermal contact. b. Warm location.
	Check Compressor: Low capacity means it is undersized for its application.

Serial Label Location & Information Listed / Technical Information & Service



- Serial labels are located near the electrical access on your case.
- Serial labels contain electrical, temperature & refrigeration information, as well as regulatory standards to which the case conforms.
- For additional technical information and service, see the *TECHNICAL SERVICE* page in this manual for instructions on contacting Structural Concepts' Technical Service Department.
- See images below for samples of both refrigerated and non-refrigerated serial labels.



888 E. Porter Rd · Muskegon, MI 49441

ENCORE[®] MODEL HV74RSS SCROLL
SERIES SERIAL NO.

FOR PARTS AND SERVICE
CALL 1-800-433-9489

3048256

CONFORMS TO UL STD 471
CONFORMS TO NSF STD 7
CERTIFIED TO CAN/CSA
STD C22.2 NO 120

ELECTRICAL RATING 120/1/60 24A

REFRIGERANT R404A AMOUNT ?? OZ

DESIGN PRESSURE HIGH 450 LOW 200

MINIMUM CIRCUIT 30A

MAXIMUM OVERCURRENT 30A

SAMPLE ONLY

Super Heat Temp	8-10°F	
BTUH Requirements	9,738 BTUH @ 20° F SST	
Defrost	6 defrosts per day, 45° F termination, 45 min. failsafe	

SAMPLE ONLY

SAMPLE ONLY

----- Sample Serial Label For Refrigerated Case -----



888 E. Porter Rd · Muskegon, MI 49441

Addenda[®] PC5682 txtRemote
txtSerialNumber

120 VOLTS 60 HZ SINGLE PHASE 1.84AMP

FOR PARTS OR SERVICE CALL
STRUCTURAL CONCEPTS
AT
1-800-433-9489



3048256

CONFORMS TO UL STD 65
CERTIFIED TO CAN/CSA
STD C22.2 NO 120

SAMPLE ONLY

----- Sample Serial Label For Non-Refrigerated Case -----

CAREL

ir33 platform

Integrated Electronic
Microprocessor Controller



Programming The Instrument

To Modify The Setpoint

Set 1. Press and hold the "SET" key for at least 1 second.

▲/aux **def/▼** 2. Use arrow keys ▲ ▼ on temperature controller to increase (or decrease) the setpoint.

Set 3. Quickly press and release the "SET" key again.

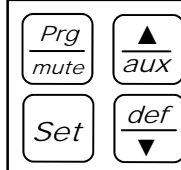

To Modify Defrost, Differential, Other Parameters

Prg/mute **Set** 1. Press & hold "Prg" & "SET" keys together for five (5) seconds; display will flash "0", representing password prompt.

Set 2. Confirm by pressing "SET" key.

▲/aux **def/▼** 3. Press ▲ or ▼ to reach the category to be modified.

Set 4. Press "SET" to modify this selected parameter.

▲/aux **def/▼** 5. Increase or decrease the value using the ▲ or ▼ button respectively.

Set 6. Press the "SET" key to temporarily save the new value and return to the display of the parameter.

Prg/mute 7. Press & hold the "Prg" key for at least 5 seconds to save changes. This action will also mute the audible alarm (buzzer) & deactivate the alarm relay.

How To Change Reading From Fahrenheit (°F) To Celsius (°C)

Prg/mute **Set** 1. Press and hold "Prg" and "SET" keys together for at least 5 seconds; display will show "0" (password prompt).

Set 2. Confirm by pressing "SET" key.

▲/aux **def/▼** 3. Press ▲ or ▼ until reaching the parameter "/ 5".

Set 4. Press "SET" to modify this selected parameter.

▲/aux **def/▼** 5. Press ▲ or ▼ to change value to desired setting: "0" for Celsius (°C) or "1" for Fahrenheit (°F).

Set 6. Press "SET" key to temporarily save the new value and return to the display of the parameter.

Prg/mute 7. Press & hold "Prg" key for at least 5 seconds to save changes. **Note! All values will automatically convert to new scale. No conversion is required.**

Warning! Save Your Parameter Settings!

1. To store the new parameter values, PRESS and HOLD the "Prg" key for at least 5 seconds.
2. All modifications made to parameters will be lost if you do NOT press a button within 60 seconds. Should this "timeout" occur, normal operational settings (prior to modifications being made) will resume.
3. If the instrument is switched off before pressing the "Prg" key, all modifications to parameters will be lost.

def/▼ **To Activate Manual Defrost**
Press and hold "def" key for at least 5 seconds.

▲/aux **To Activate / Deactivate Auxiliary Output**
Press and hold the "aux" key for 1 second.

Prg/mute **▲/aux** **To Reset Any Alarms With Manual Reset**
Press and hold the "Prg" and "aux" key for at least 1 second.

Read And S

CAREL

ir33 platform

**Integrated Electronic
Microprocessor Controller**



User Interface - Display

ICON	FUNCTION	DESCRIPTION	Normal operation			Start up
			ON	OFF	BLINK	
	COMPRESSOR	ON when the compressor starts. Flashes when the activation of the compressor is delayed by safety times.	Compressor on	Compressor off	awaiting activation	
	FAN	ON when the fan starts. Flashes when the activation of the fan is prevented due to external disabling or procedures in progress.	Fan on	Fan off	awaiting activation	
	DEFROST	ON when the defrost is activated. Flashes when the activation of the defrost is prevented due to external disabling or procedures in progress.	Defrost in progress	Defrost not in progress	awaiting activation	
	AUX	Flashes if the anti-sweat heater function is active, ON when the auxiliary output (1 and/or 2) selected as AUX (or LIGHT in firmware version 3.6) is activated.	AUX auxiliary output active (version 3.6 light auxiliary output active)	AUX auxiliary output not active	Anti-sweat heater function active	
	ALARM	ON following pre-activation of the delayed external digital input alarm. Flashes in the event of alarms during normal operation (e.g. high/low temperature) or in the event of alarms from an immediate or delayed external digital input.	Delayed external alarm (before the time 'A7' elapses)	No alarm present	Alarms in norm. operation (e.g. High/low temperature) or immediate or delayed alarm from external digital input	
	CLOCK	ON if at least one timed defrost has been set. At start-up, comes ON for a few seconds to indicate that the Real Time Clock is fitted.	If at least 1 timed defrost event has been set	No timed defrost event set	Alarm clock	ON if real-time clock present
	LIGHT	Flashes if the anti-sweat heater function is active, ON when the auxiliary output (1 and/or 2) selected as LIGHT is activated (in firmware version 3.6 it does not flash in anti-sweat heater mode and comes on when the dead band output is active).	Light auxiliary output on (version 3.6 dead band auxiliary output active)	Light auxiliary output off	Anti-sweat heater function active (version 3.6 does not flash in anti-sweat heater mode)	
	SERVICE	Flashes in the event of malfunctions, for example E2PROM errors or probe faults.		No malfunction	Malfunction (e.g. E2PROM error or probe fault). Contact service	
	CONTINUOUS CYCLE	ON when the CONTINUOUS CYCLE function is activated. Flashes if the activation of the function is prevented due to external disabling or procedures in progress (E.g.: minimum compressor OFF time).	CONTINUOUS CYCLE operation activated	CONTINUOUS CYCLE function not activated	CONTINUOUS CYCLE operation requested	

Summary Table of Alarm and Signals: Display, Buzzer and Relay

Code	Icon on the display	Alarm relay	Buzzer	Reset	Description
rE	flashing	on	on	automatic	virtual control probe fault
E0	flashing	off	off	automatic	room probe S1 fault
E1	flashing	off	off	automatic	defrost probe S2 fault
E2	flashing	off	off	automatic	probe S3 fault
E3	flashing	off	off	automatic	probe S4 fault
E4	flashing	off	off	automatic	probe S5 fault
'	No	off	off	automatic	probe not enabled
LO	flashing	on	on	automatic	low temperature alarm
HI	flashing	on	on	automatic	high temperature alarm
AFr	flashing	on	on	manual	antifreeze alarm
IA	flashing	on	on	automatic	immediate alarm from external contact
dA	flashing	on	on	automatic	delayed alarm from external contact
dEF	on	off	off	automatic	defrost running
Ed1	No	off	off	automatic/manual	defrost on evaporator 1 ended by timeout
Ed2	No	off	off	automatic/manual	defrost on evaporator 2 ended by timeout
Pd	flashing	on	on	automatic/manual	maximum pump down time alarm
LP	flashing	on	on	automatic/manual	low pressure alarm
AtS	flashing	on	on	automatic/manual	autostart in pump down
cht	No	off	off	automatic/manual	high condenser temperature pre-alarm
CHT	flashing	on	on	manual	high condenser temperature alarm
dor	flashing	on	on	automatic	door open too long alarm
EE	flashing	off	off	automatic	E2prom error, unit parameters
EF	flashing	off	off	automatic	E2prom error, operating parameters
ccb	Signal				start continuous cycle request
ccE	Signal				end continuous cycle request
dFb	Signal				start defrost call
dFE	Signal				end defrost call
On	Signal				switch ON
off	Signal				switch OFF
rES	Signal				reset alarms w/manual reset / reset HACCP alarms / reset temp. monitoring

CAREL

ir33 platform

Integrated Electronic
Microprocessor Controller



Summary Table of Operating Parameters

CODE	PARAMETER	UOM*	TYPE	MINIMUM	MAXIMUM	DEFAULT
/5	Select Celsius (°C) or Fahrenheit (°F)	flag	C	0	1	For Case Specific Defaults See Serial Label Located Near Electrical Access On Your Case. For Additional Technical Information Call Structural Concepts Technical Service Dept. at 1(800) 433.9489
/c1	Calibration of probe 1	°C/°F	C	-20	20	
/c2	Calibration of probe 2	°C/°F	C	-20	20	
St	Temperature set point	°C/°F	F	r2	r1	
rd	Control delta	°C/°F	F	20	0.1	
dl	Interval between defrosts	hours	F	0	250	
dt1	End defrost temperature, evaporator	°C/°F	F	-50	200	
dP1	Maximum defrost duration, evaporator	min	F	1	250	
d6	Display on hold during defrost	-	C	0	2	
dd	Dripping time after defrost	min	F	0	15	
d/1	Display of defrost probe 1	°C/°F	F	-	-	

* Unit Of Measure

SCC TECHNICAL SERVICE CONTACT INFORMATION & WARRANTY INFORMATION

STRUCTURAL CONCEPTS CORPORATION TECHNICAL SERVICE
PHONE NUMBER: 1.800.433.9489 or For Your Master Service Agent See
WWW.STRUCTURALCONCEPTS.COM/Contact/Master_Service_Agents.asp

LIMITED WARRANTY

All sales by Structural Concepts Corporation (SCC) are subject to the following limited warranty. "Goods" refers to the product or products being sold by SCC.

Warranty Scope: Warranty is for equipment sold in the United States, Canada, Mexico and Puerto Rico. Equipment sold elsewhere may carry modified warranty.

Warranty; Remedies; Limitations. SCC warrants that if any Goods are found by an authorized representative of SCC not to be of good material or workmanship within one year of the date of shipments SCC will, at its option after inspection by an authorized representative, replace any defective Good or pay the reasonable cost of replacement for any such defective Goods, provided that written notice of the defect is given to SCC within 30 days of the appearance of such defect. If notice is not given within such period, any claim for breach of warranty shall be conclusively deemed to have been waived and SCC shall not be liable under this warranty. If SCC is unable to repair or replace the defective Goods, SCC shall issue a credit to the Purchaser for all or part of the purchase price, as SCC shall determine. The replacement or payment in the manner described above shall be the sole and exclusive remedy of Purchaser for a breach of this warranty. If any Goods are defective or fail to conform to this warranty, SCC will furnish instructions for their disposition. No Goods shall be returned to SCC without its prior consent.

SCC's liability for any defect in the Goods shall not exceed the purchase price of the Goods. SCC SHALL HAVE NO LIABILITY TO PURCHASE FOR CONSEQUENTIAL DAMAGES OF ANY KIND WHATSOEVER, INCLUDING, BUT NOT LIMITED TO, PERSONAL INJURY, PROPERTY DAMAGE, LOST PROFITS, OR OTHER ECONOMIC INJURY DUE TO ANY DEFECT IN THE GOODS OR ANY BREACH OF SCC, SCC SHALL NOT BE LIABLE TO THE PURCHASER IN TORT FOR ANY NEGLIGENT DESIGN OR MANUFACTURE OF THE GOODS, OR FOR THE OMISSION OF ANY WARNING THEREFROM.

SCC shall have no obligation or liability under this warranty for claims arising from any other party's (including Purchaser's) negligence or misuse of the Goods or environmental conditions. This warranty does not apply to any claim or damage arising for or caused by improper storage, handling, installation, maintenance, or from fire, flood, accidents, structural defects, building settlement or movement, acts of God, or other causes beyond SCC's control.

Except as expressly stated herein, SCC makes no warranty, express, implied, statutory or otherwise as to any parts or goods not manufactured by SCC. SCC shall warrant such parts or Goods only (I) against such defects, (II) for such periods of time, and (III) with such remedies, as are expressly warranted by the manufacturer of such parts of Goods. Notwithstanding the foregoing, any warranty with respect to such parts of Goods and any remedies available as a result of a breach thereof shall be subject to all of the procedures, limitations, and exclusions set forth herein.

THE WARRANTIES HEREIN ARE IN LIEU OF ALL WARRANTIES, EXPRESS, IMPLIED, STATUTORY, OR OTHERWISE. IN PARTICULAR, SCC MAKES NO WARRANTY OF MERCHANTABILITY OR FITNESS FOR A PARTICULAR PURPOSE.

No representative, agent or dealer of SCC has authority to modify, expand, or extend this Warranty, to waive any of the limitations or exclusions, or to make any different or additional warranties with respect to Goods.

Period of Limitations. No claim, suit or other proceeding may be brought by Purchaser for any breach of the foregoing warranty or this Agreement by SCC or in any way arising out of this Agreement or relating to the Goods after one year from the date of the breach. In the interpretation of this limitation on action for a breach by SCC, it is expressly agreed that there are no warranties of future performance of the goods that would extend that period of limitation herein contained for bringing an action.

Indemnifications. Purchaser agrees to indemnify, hold harmless, and defend SCC if so requested, from any and all liabilities, as defined herein, suffered, or incurred by SCC as a result of, or in connection with, any act, omission, or use of the Goods by Purchaser, its employees or customers, or any breach of this Agreement by Purchaser. Liabilities shall include all costs, claims, damages, judgments, and expenses (including reasonable attorney fees and costs).

Remedies of SCC. SCC's rights and remedies shall be cumulative and may be exercised from time to time. In a proceeding or action relating to the breach of this Agreement by Purchaser, Purchaser shall reimburse SCC for reasonable costs and attorney's fees incurred by SCC. No waiver by SCC of any breach of Purchaser shall be effective unless in writing nor operate as a waiver of any other breach of the same term thereafter. SCC shall not lose any right because it has not exercised it in the past.

Applicable Law. This Agreement is made in Michigan and shall be governed by and interpreted according to Michigan law. Any lawsuit arising out of this Agreement or the Goods may be handled by a federal or state court whose district includes Muskegon County, Michigan, and Purchaser consents that such court shall have personal jurisdiction over Purchaser.

Miscellaneous. If any provision of this Agreement is found to be invalid or unenforceable under any law, the provision shall be ineffective to that extent and for the duration of the illegality, but the remaining provisions shall be unaffected. Purchaser shall not assign any of its rights nor delegate any of its obligations under this Agreement without prior written consent of SCC. This Agreement shall be binding upon and inure to the benefit of SCC and Purchaser and each of their legal representatives, successors and assigns.

SCC warrants its products to be free of defects in materials and workmanship under normal use and service for a period of one (1) year from the date of delivery.

This warranty is extended only to the original purchaser for use of the Goods. It does not cover normal wear parts such as plastic tongs, tong holders, tong cables, bag holders, or acrylic dividers.

General Conditions. All service labor and/or parts charges are subject to approval by SCC. Contact the Customer Service Department in writing or call 231-798-8888.

All claims must contain the following information: (1) model & serial code number of equipment; (2) the date and place of installation; (3) the name and address of the agency which performed the installation; (4) the date of the equipment failure; and (5) a complete description of the equipment failure and all circumstances relating to that failure.

Once the claim has been determined to be a true warranty claim by SCC's Customer Service Department, the following procedure will be taken: (1) replacement parts will be sent at no charge from SCC on a freight prepaid basis; (2) reimbursement for service labor will be paid if the following conditions have been met - (a) prior approval of service agency was awarded from the Customer Service Department; and (b) an itemized statement of all labor charges incurred is received by the Customer Service Department. The cost of the service labor reimbursement will be based on straight time rates and reasonable time for the repair of the defect.

If problems occur with any compressor, notify SCC's Customer Service Department immediately. Any attempt to repair or alter the unit without prior consent from the Customer Service Department will render any warranty claim null and void. This warranty and protection plan does not apply to any condensing unit or any part thereof which has been subject to accident, negligence, misuse, or abuse, or which has not been operated in accordance with the manufacturer's recommendations or if the serial number of the unit has been altered, defaced, or removed.

Limit of Liability. The limit of liability of SCC toward the exchange cost of the original condensing unit, F.O.B. SCC, Norton Shores, MI, of each motor-compressor assembly replaced during the warranty shall not exceed manufacturer's current established wholesaler's exchange price and in no case shall the labor of removing or replacing the motor-compressor or parts thereof be the responsibility of SCC.